



**THE DATASHEET OF
MAX9286GTN+**



MAX9291/MAX9293 Evaluation Kit

Evaluates: MAX9291/MAX9293

General Description

The MAX9291/MAX9293 evaluation kit (EV kit) provides a proven design to evaluate the MAX9291/MAX9293 HDMI input with high-bandwidth gigabit multimedia serial link (GMSL) output serializer with spread spectrum and full-duplex control channel with the use of a standard FAKRA coaxial cable. The EV kit also includes Windows Vista®- and Windows® 7-compatible software that provides a simple graphical user interface (GUI) for exercising features of the serializers. The EV kit comes with a MAX9291 or MAX9293 IC installed.

For complete GMSL evaluation using a standard FAKRA coax cable, order the MAX9291/MAX9293 coax EV kit and a companion serializer board (MAX9276A/MAX9280A coax EV kit referenced in this document). For testing with STP cable, also order the MAXCOAX2STP-HSD adapter kit. Only one adapter kit is needed per link (connecting the serializer and deserializer boards).

Features

- HDMI Input GMSL Serial Output
- Windows Vista- and Windows 7-Compatible Software
- USB-Controlled Interface (Cable Included)
- USB Powered
- Proven PCB Layout
- Fully Assembled and Tested

Note: In the following sections, “serializer” refers to the MAX9291 or MAX9293 ICs and “deserializer” refers to the MAX9276A or MAX9280A ICs.

Note: To evaluate the product with shielded twisted-pair (STP) cable, refer to the MAXCOAX2STP-HSD data sheet.

Note: This document applies to both coax and STP EV kits. This document covers coax cables, but the information provided applies equally to STP cables.

Items Included in the EV Kit Package

DESCRIPTION	QTY
MAX9291 coax EV kit or MAX9293 coax EV kit boards	1
USB cable	1

MAX9291/MAX9293 EV Kit Files

FILE	DESCRIPTION
MAXSerDesEV-N_Vxxxx_Install.EXE	Installs the EV kit files on the PC
MAXSerDesEV-N.EXE	Graphical-user interface (GUI) program

Quick Start

Required Equipment

- MAX9291 or MAX9293 coax EV kit (USB cable included)
- MAX9276A or MAX9280A coax EV kit
- 2m FAKRA cable assembly (included in the MAX9276A/MAX9280A coax EV kit)
- HDMI data source
- PC running Windows Vista or Windows 7, with a spare USB port (direct 500mA connection required; do not use a bus-powered hub)
- 5V DC, 500mA power supply

Note: In the following sections, software-related items are identified by **bolding**. Text in **bold** refers to items directly from the EV kit software. Text in **bold and underlined** refers to items from the Windows operating system.

Ordering Information appears at end of data sheet.

Windows, Windows Vista, and Windows 7 are registered trademarks and registered service marks of Microsoft Corporation.

Procedure

The EV kit is fully assembled and tested. Follow the steps below to verify board operation:

- 1) Download and install the EV kit software, MAXSerDesEV-N.EXE. The application will try to download and install the USB driver for the Nuvoton microcontroller. If the USB driver installation is not successful, install the appropriate USB driver for your computer, which is available at www.ftdichip.com/Drivers/VCP.htm.
- 2) Verify that jumpers on the serializer board are in their default positions, as shown in [Figure 12](#).
- 3) Verify that jumpers on the deserializer board are in their default positions, as shown in [Figure 13](#).
- 4) Power up the serializer by connecting the USB cable between the PC's USB port and connector J10 on the serializer board.
- 5) Power up the deserializer by connecting the positive/negative terminals of the power supply to the +5VIN/GND terminals on the deserializer board.
- 6) Connect the FAKRA cable from the OUT+ terminal on the serializer board to the IN+ terminal on the deserializer board.
- 7) Turn on the power supply to power the deserializer board.
- 8) Connect the HDMI source to the HDMI connector (J1) on the serializer EV kit board.
- 9) Verify that LOCK LED on the deserializer EV kit board lights up, indicating that the link has been successfully established.
- 10) Input data should be available on the H1 header on the deserializer board.
- 11) If the LOCK LED is off, or ERR LED is on, go to the *Troubleshooting* section at the end of this document and fix the problem before continuing.
- 12) Start the EV kit software by selecting **Start | Programs | Maxim Integrated | MAXSerDesEV-N | MAXSerDesEV-N**.
- 13) In case a more recent firmware than the firmware currently in the microcontroller is available, a

warning will be displayed at GUI startup ([Figure 1](#)), informing the user that a new version of the firmware is available. You can continue operating the EV kit with the current firmware, or update it. To update the firmware, follow the instructions in **C:\Program Files\Maxim Integrated\MAXSerDesEV-N\Firmware Update\Updating MAXSerDesEV-N firmware.pdf**.

- 14) A window will pop open ([Figure 3](#)) indicating that all control-channel-related jumpers along with other jumpers have been positioned correctly. If the GUI does not find a valid EV kit board (an operating evaluation board with a Nuvoton microcontroller), a window similar to [Figure 2](#) will appear. Press **OK** to continue and start the GUI or press **Cancel** to terminate the application. Go to the *Troubleshooting* section at the end of this document and fix the problem before continuing.
- 15) If an operating evaluation board is found, the **Configuration Settings** window appears ([Figure 3](#)), and the GUI automatically searches the slave addresses and identifies the DUTs based on the **Device IDs** read from the DUTs internal registers.
- 16) Once the **Configuration Settings** window is open, press the **Identify Devices** button at any time to reidentify devices connected in the setup and display corresponding jumpers to configure the serializer and deserializer.
- 17) Only **Link Type** and **Device Address** selections on the **Configuration Settings** window affect the EV kit operation. Other items are for user reference only.
- 18) Press the **Connect** button to open the **Evaluation Kit** window and DUTs' register maps ([Figure 4](#)). All serializer and deserializer internal registers are read and displayed on the corresponding tabs.
- 19) Press the **Read All MAX9291** button in the **Serializer** group box to read all serializer registers.
- 20) Click on the **MAX9280/80A Des** tab and then press the **Read all MAX9280** button in the **Deserializer** group box to read all deserializer registers.
- 21) Click on any of the other tabs to evaluate other functions of the serializer and deserializer.

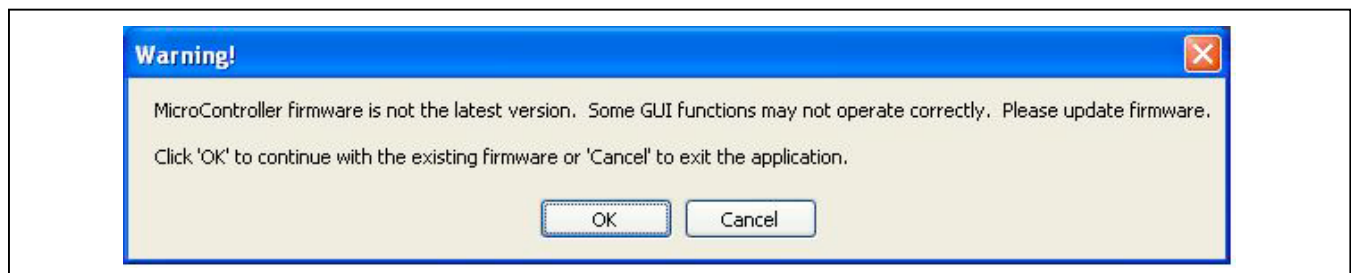

Figure 1. MAXSerDesEV-N EV Kit Software: Warning! (Update Firmware)

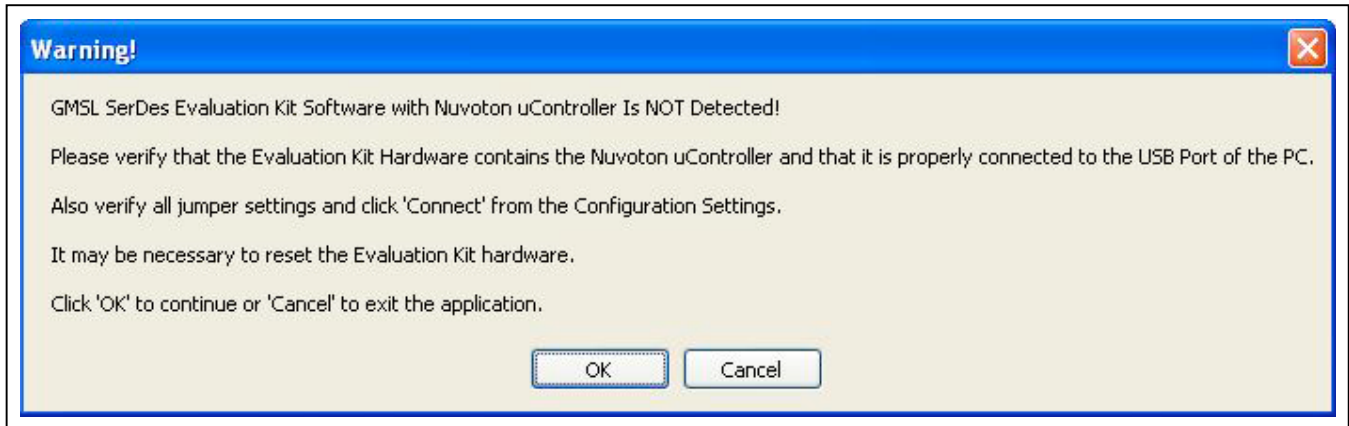

Figure 2. MAXSerDesEV-N EV Kit Software: Warning! (reporting EV Kit with Nuvoton Microcontroller is NOT Detected!)

Table 1. Jumper Settings/Descriptions

JUMPER*	SIGNAL	DEFAULT POSITION	FUNCTION
J1	HDMI	—	HDMI input connector
J2 (Note 1)	LMN1_REM	Short	OUT- line-fault function on remote device, deserializer (J4 must be open)
		Open**	OUT- line-fault function is on local device, serializer (J4 must be short)
J3	RSVD44	Short**	Reserved (keep shunt inserted at all times)
J4 (Note 1)	LMN1_LOC	Short**	OUT- line-fault function on local device, serializer (J2 must be open)
		Open	OUT- line-fault function on remote device, deserializer (J2 must be short)
J5	SCL_PU	Short**	TX/SCL line pulled up to IOVDD
		Open	TX/SCL line not pulled up (use external pullups)
J6	I-IOVDD	Short**	IOVDD voltage applied to U9
		Open	Insert amp meter to measure U1 IOVDD current
J7	+12V	—	AC adapter power input
J8 (Note 1)	LMN0_LOC	Short**	OUT+ line-fault function is on local device, serializer (J11 must be open)
		Open	OUT+ line-fault function on remote device, deserializer (J11 must be short)
J9	ICE-DEBUG	—	Connect Nu-Link-Pro dongle to program Nuvoton µC boot loader
J10	J10	—	Mini-USB connector
J11 (Note 1)	LMN0_REM	Short	OUT+ line-fault function on remote device, deserializer (J8 must be open)
		Open**	OUT+ line-fault function is on local device, serializer (J8 must be short)
J12	EXT_UC	—	4-pin header to connect external µC terminals, I ² C, or UART
J13	DDCSCL	Short**	HDMI SCL pulled up
		Open	HDMI SCL not pulled up
J16	SDA_PU	Short**	RX/SDA line pulled up to IOVDD
		Open	RX/SDA line not pulled up (use external pullups)
J17	LMN_V	Short	Top of LFLT circuit pulled up to AVDD 1.8V
		Open**	Insert amp meter to current measurement
J18	J18	Short**	POC circuit powered
		Open	POC circuit not powered

Table 1. Jumper Settings/Descriptions (continued)

JUMPER*	SIGNAL	DEFAULT POSITION	FUNCTION
J19	DDCSDA	Short**	HDMI SDA pulled up
		Open	HDMI SDA not pulled up
J21	VDD_REF	Short**	Use internal 3.3V for external μ C digital signals
		Open	External μ C digital signals level are applied on J12.1
JU1	HS_DRS	IOVDD	Select low data-rate mode
		GND**	Select high data-rate mode
JU2	HS_AUTOS	IOVDD	Disable serialization
		GND**	Disable serialization
JU3	VDD	USB+5V**	Board powered from USB port
		+5VIN	Board powered from +5VIN terminals
		REG	Board powered from AC adapter
JU4	HS_HIM	IOVDD**	Set reverse channel to high-immunity mode
		GND	Set reverse channel to legacy mode
JU5 (Note 2)	HS_TX-SCL	Left (SCL)**	Communicate in I ² C mode
		Right (TX)	Communicate in UART mode
JU6 (Note 2)	HS_RX-SDA	Left (SDA)**	Communicate in I ² C mode
		Right RX)	Communicate in UART mode
JU7	XVDD	INT**	Use on-board 3.3V for XVDD
		EXT	Use external 3.3V for XVDD
JU8	PLLVDD	INT**	Use on-board 3.3V for PLLVDD
		EXT	Use external 3.3V for PLLVDD
JU9	RVDD	INT**	Use on-board 1.8V for RVDD
		EXT	Use external 1.8V for RVDD
JU18 (Note 2)	(HS_I2CSEL)	I2C**	Set communication to I ² C mode
		UART	Set communication to UART mode
JU19	HS_ADD1	H	ADD1 = high (see Table 2)
		L**	ADD1 = low (see Table 2)
JU20	HS_ADD0	H	ADD0 = high (see Table 2)
		L**	ADD0 = low (see Table 2)
JU22	HS_CNTL1	H	Additional input data bit (fix input bit to high level)
		L	Additional input data bit (fix input bit to low level)
		Open**	Apply user data bit to middle pin
JU23	HS_CNTL2	H	Additional input data bit (fix input bit to high level)
		L	Additional input data bit (fix input bit to low level)
		Open**	Apply user data bit to middle pin
JU24	HS_SSEN	H	Spread spectrum set to $\pm 0.5\%$
		L**	Spread spectrum off
JU25	HS_MS	H	Select bypass mode
		L**	Select base mode

Table 1. Jumper Settings/Descriptions (continued)

JUMPER*	SIGNAL	DEFAULT POSITION	FUNCTION
JU26	HS_CDS	H	Control-channel master μ C is connected to the deserializer
		L**	Control-channel master μ C is connected to the serializer
JU27	HS_PWDN	H**	Serializer is powered down, disabled
		L	Serializer is powered up, enabled
JU28 (Note 3)	HS_BWS	H	32-bit mode
		L**	Does not apply
		Open	High-bandwidth mode
JU30	AVDD	INT**	Use on-board 1.8V for AVDD
		EXT	Use external 1.8V for AVDD
JU31	DVDD	INT**	Use on-board 1.8V for DVDD
		EXT	Use external 1.8V for DVDD
JU32	HVDD	INT**	Use on-board 3.3V for HVDD
		EXT	Use external 3.3V for HVDD
JU33	IOVDD	4-1.8V	Set IOVDD to 1.8V
		2-3.3V**	Set IOVDD to 3.3V
		3-2.5V	Set IOVDD to 2.5V
JU34	HS_CX_TP	H**	Set CX/STP pin for coax cable
		L	Set CX/STP pin for STP cable

*Jumper selections in the Serializer/Deserializer group boxes on the **Configuration Settings** window are for reference only and do not affect software operation.

**Default position.

Notes:

- 1: Do not activate LFLT functions on both ends of the same channel.
- 2: JU5, JU6, and JU18 must be set consistently.
- 3: JU28 (set BWS to the same level on both sides of the serial link).

Table 2. Device Address Selection

PIN		DEVICE ADDRESS (binary)								SERIALIZER DEVICE ADDRESS (hex)	DESERIALIZER DEVICE ADDRESS (hex)
ADD1	ADD0	D7	D6	D5	D4	D3	D2	D1	D0		
Low	Low	1	0	0	X*	0	0	0	R/W	80	90
Low	High	1	0	0	X*	0	1	0	R/W	84	94
Low	Open	1	0	0	X*	1	0	0	R/W	88	98
High	Low	1	1	0	X*	0	0	0	R/W	C0	D0
High	High	1	1	0	X*	0	1	0	R/W	C4	D4
High	Open	1	1	0	X*	1	0	0	R/W	C8	D8
Open	Low	0	1	0	X*	0	0	0	R/W	40	50
Open	High	0	1	0	X*	0	1	0	R/W	44	54
Open	Open	0	1	0	X*	1	0	0	R/W	48	58

*X = 0 for the serializer address; X = 1 for the deserializer address.

Detailed Description of Software

To start the MAX9291/MAX9293 EV kit GUI, select: **Start | Programs | Maxim Integrated | MAXSerDesEV-N | MAXSerDesEV-N.**

Configuration Settings Window

The **Configuration Settings** window is the first window that opens after program launch. It allows the user to specify serializer and deserializer evaluation board setup and modes of operation (Figure 3).

Controller Group Box

In the **Controller** group box, select **Coax** or **STP** from the **Link Type** drop-down list, **I2C** or **UART** from the **Bus** drop-down list, and whether the **Serializer** or **Deserializer** should connect to the USB controller. Upon changing any of these parameters, the selection in the jumper listing below changes automatically, prompting the user to make the corresponding changes to the jumper on the EV kit boards.

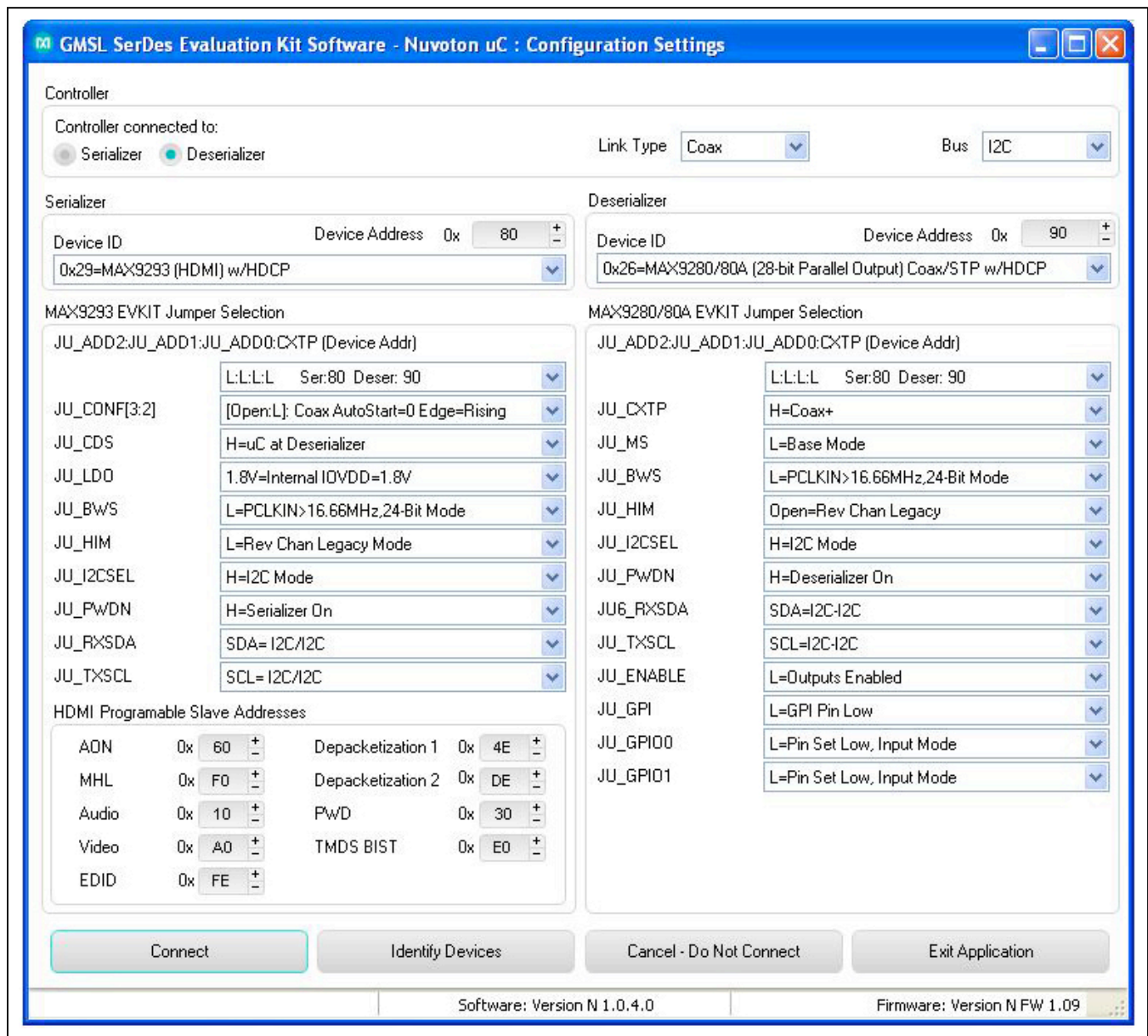

Figure 3. MAXSerDesEV-N EV Kit Software: Configuration Settings Window (Shown with MAX9293 and MAX9280A EV Kits Connected)

Serializer Jumper Selection Block

The **Serializer Jumper Selection** block lists jumpers on the evaluation board of the selected **Device ID** and displays the correct shunt positions based on the conditions selected in the **Controller** group box.

Deserializer Jumper Selection block

The **Deserializer Jumper Selection** block lists jumpers on the evaluation board of the selected **Device ID** and displays the correct shunt positions based on the conditions selected in the **Controller** group box.

Identify Devices Button

The **Identify Devices** button causes the GUI to scan the system and search for slave addresses on the bus. Upon successful communication, it reads the **Device ID** register from the device and displays the corresponding jumper lists on the **Serializer Jumper Selection** and **Deserializer Jumper Selection** blocks. It is also possible to manually select a device from the **Device ID** drop-down list and enter a slave address in the **Device Address** edit box. It is a good practice to utilize the **Identify Devices** button and verify communication with the DUTs before attempting to **Connect**.

[Figure 12](#) and [Figure 13](#) show jumper settings on the MAX9291/MAX9293 and MAX9276A/MAX9280A PCBs for coax or STP cable and UART or I²C communication with the USB controller connected to the serializer board. Refer to the respective serializer/deserializer IC data sheets for detailed configuration information. See [Table 1](#) for PCB jumper settings/descriptions. The following sections provide a brief overview of functional buttons on the **Configuration Settings** window.

Device Address Edit Box

It is a good practice to utilize the **Device Address** edit box and verify communication with the DUTs before attempting to **Connect**.

Connect Button

The **Connect** button opens up the **Evaluation Kit** window. The GUI reads the serializer and deserializer registers and updates the register maps for both. Successful communication is indicated by green LED indicators. In case of a communication problem, the LED indicators turn red.

Cancel - Do Not Connect Button

The **Cancel - Do Not Connect** button opens the **Evaluation Kit** window without attempting to connect to the microcontroller. Although there will be no

communication with the microcontroller, all functions and tabs corresponding to the selected **Device IDs** on the **Evaluation Kit** window become active once there.

Evaluation Kit Window

The **Evaluation Kit** window shown in [Figure 4](#) provides access to all internal registers and functions of the DUTs by means of reading and writing registers through different tabs that allow the user to evaluate various functions of the serializer and deserializer.

The **Read All** button updates the serializer and deserializer register maps by reading the DUT's internal registers.

The **Serializer** group box provides pushbuttons to update the serializer's register map from the DUT using the **Read All MAX9291** button, update from a previously saved file using the **Load** button, or save the existing register values into a file using the **Save** button.

The **Deserializer** group box provides pushbuttons to update the deserializer's register map from the DUT using the **Read All MAX9276** button, update from a previously saved file using the **Load** button, or save the existing register values into a file using the **Save** button.

The **Wake Up** button applies the register write sequence described in the IC data sheets to wake up the DUTs from sleep mode.

The **Open Configuration** button reopens the **Configuration Settings** window.

The following sections describe the tabs available on the **Evaluation Kit** window.

MAX9291 Ser Tab

The **MAX9291 Ser** tab ([Figure 4](#)) lists the serializer registers' bitmaps. **Read** and **Write** buttons in each register group box allow access to each bit or group of bits that specify a function or condition, as defined in the serializer IC data sheet. The color of the small LED indicator next to the **Read/Write** buttons indicates the communication status. Green indicates successful communication and red indicates failed communication.

MAX9276 Des Tab

The **MAX9276 Des** tab ([Figure 5](#)) lists the deserializer registers' bitmaps. **Read** and **Write** buttons in each register group box allow access to each bit or group of bits that specify a function or condition, as defined in the deserializer IC data sheet. The color of the small LED indicator next to the **Read/Write** buttons indicates the communication status. Green indicates successful communication and red indicates failed communication.

Additional Features Tab

The **Additional Features** tab (Figure 6) provides push-buttons for specific functions that the connected devices can perform. By pressing the buttons, a window will pop up that allows the specific function to be utilized/executed. Functions that are not supported by the selected devices are grayed out.

Access EDID Table Contents Button

The **Access EDID Table Contents** button provides access to the **EDID Table** (Figure 7). Use this table to program/view/edit the **EDID Table** content. The **EDID Table** can be uploaded from a valid existing file and the content can also be saved to a file (in .csv format) for reference, or for use as a template.

Access Lookup Table Button

The **Access Lookup Table** button provides access to the **Lookup Tables** (LUT) of the deserializer (Figure 8). Use this window to program/view/edit the LUT settings of the red, green, and blue colors for color translation. LUT content edits can be performed on the entire 256 bytes of all three colors, on an individual color table, or individual pixels of any color table. The LUT' contents can be saved to a file (in .csv format) for reference or for use as a template. LUT contents can be uploaded from a valid existing file. A sample LUT content is included in the EV kit software package. This window is functional only for DUTs that support color mapping.

Show PRBS Test Button

By pressing the **Start** button in the expanded window shown in Figure 9, the serializer and deserializer registers are programmed per defined sequence in the IC data sheets to perform a pseudorandom bit sequence (PRBS) error-rate test. Enter test duration (maximum 32,767s = 9.1hrs) in the **Duration** edit box and press **Start** to begin the test. At test completion, the number of bit errors will be read from the PRBSERR register and displayed in the **PRBS Error Counter** box.

Log\Low Level Tab

The **Log\Low Level** tab (Figure 10) logs all activities between GUI and DUTs.

The **Register Access** group box includes **Read** and **Write** buttons to specify the slave and register addresses. Use the **Send String to EVKIT** button for communication with devices that are not register-based (such as the MAX7324). The **SerDes Baud Rate** drop-down list sets the communications baud rate. Note that the baud rate should be changed in small increments/decrements (one step change at a time is recommended).

HDPC Tab

The **HDPC** tab (Figure 11) displays the HDPC registers of both serializer and deserializer, listed side-by-side with **Read** and **Write** buttons for each register. **Authenticate** and **Enable Encryption** pushbuttons initiate the HDPC verification process. At the end of the operation, the color of the LED indicator next to the button indicates success or failure of the function. **Note:** This tab is only functional for DUTs that support the HDPC function.

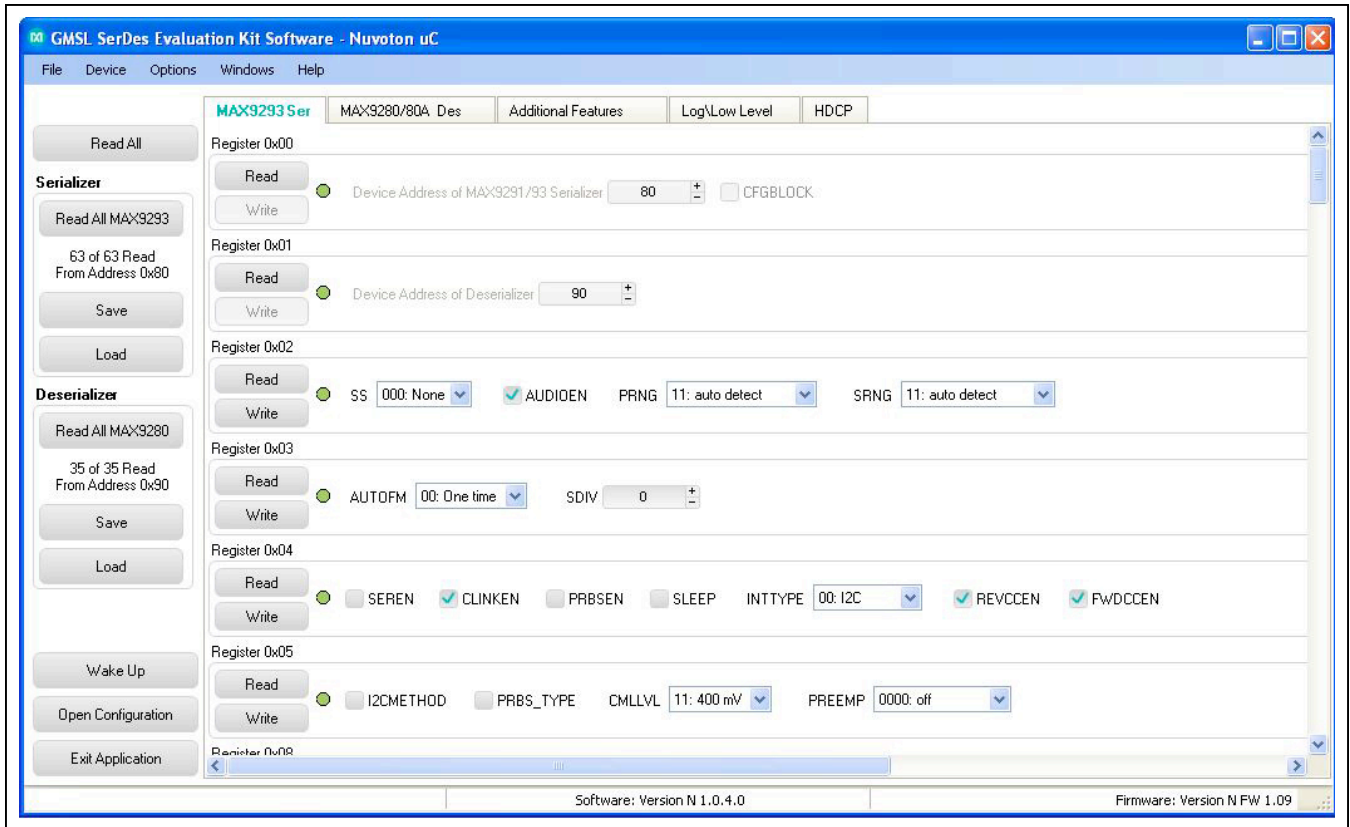

Figure 4. MAXSerDesEV-N EV Kit Software: Evaluation Kit Window (MAX9293 Ser Tab (Serializer))

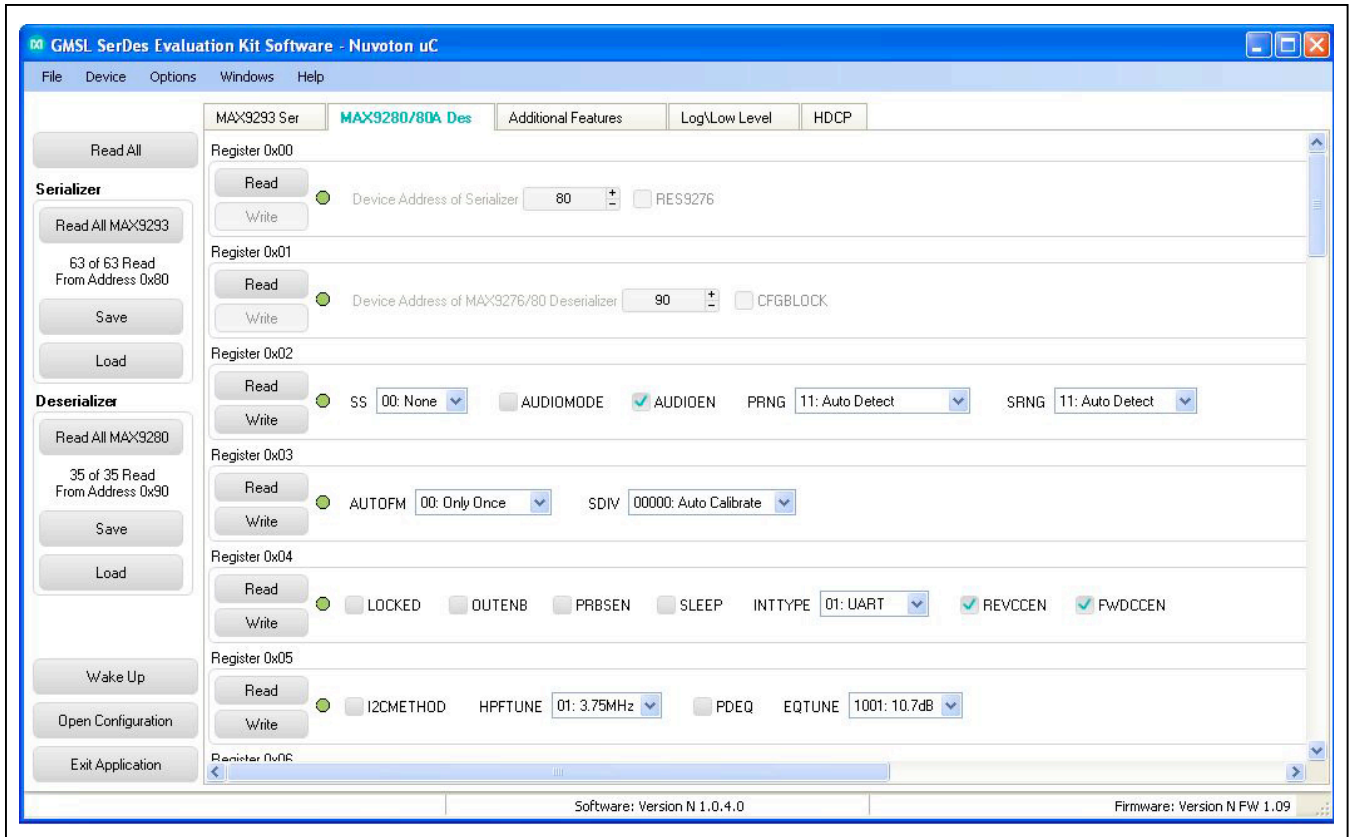

Figure 5. MAXSerDesEV-N EV Kit Software: Evaluation Kit Window (MAX9280/80A Des Tab (Deserializer))

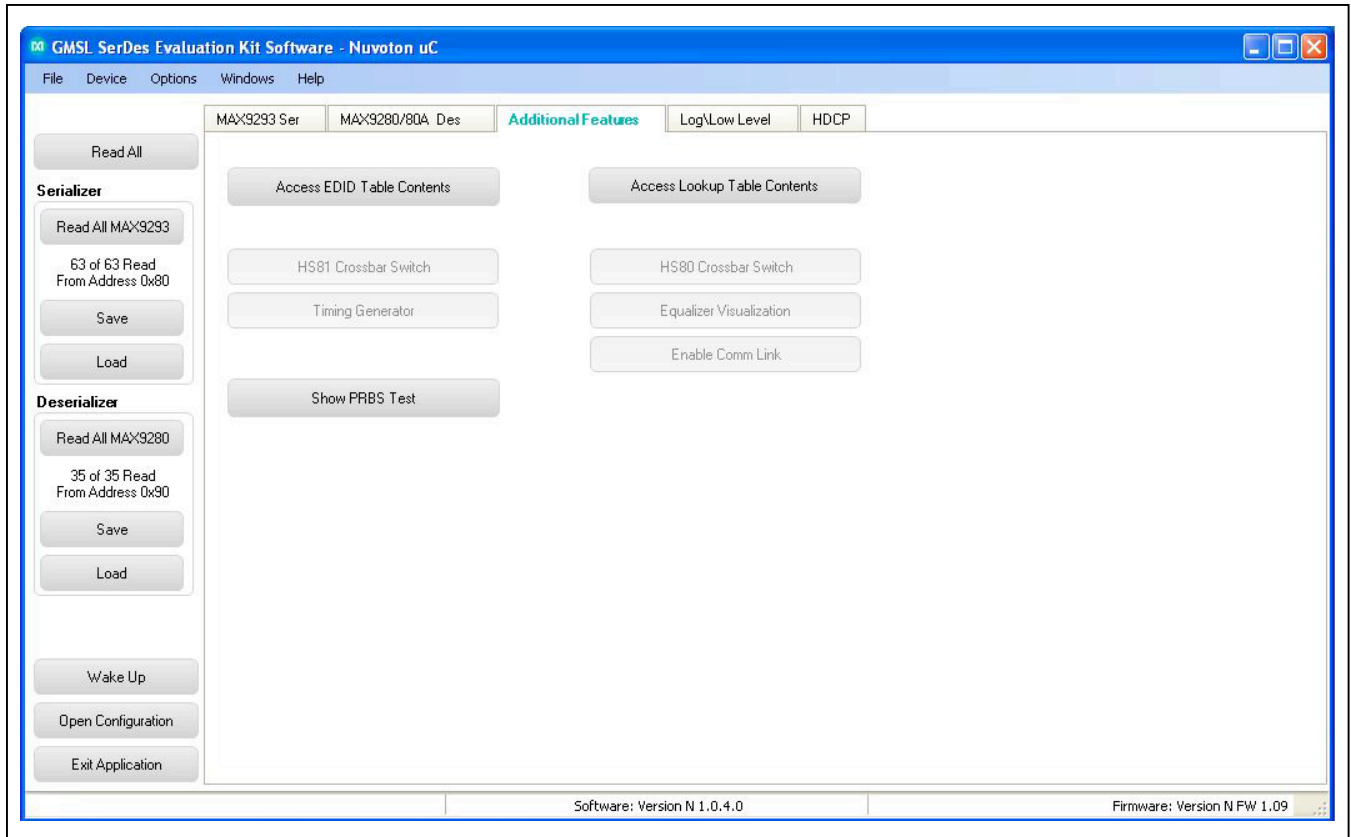

Figure 6. MAXSerDesEV-N EV Kit Software: Evaluation Kit Window (Additional Features Tab)

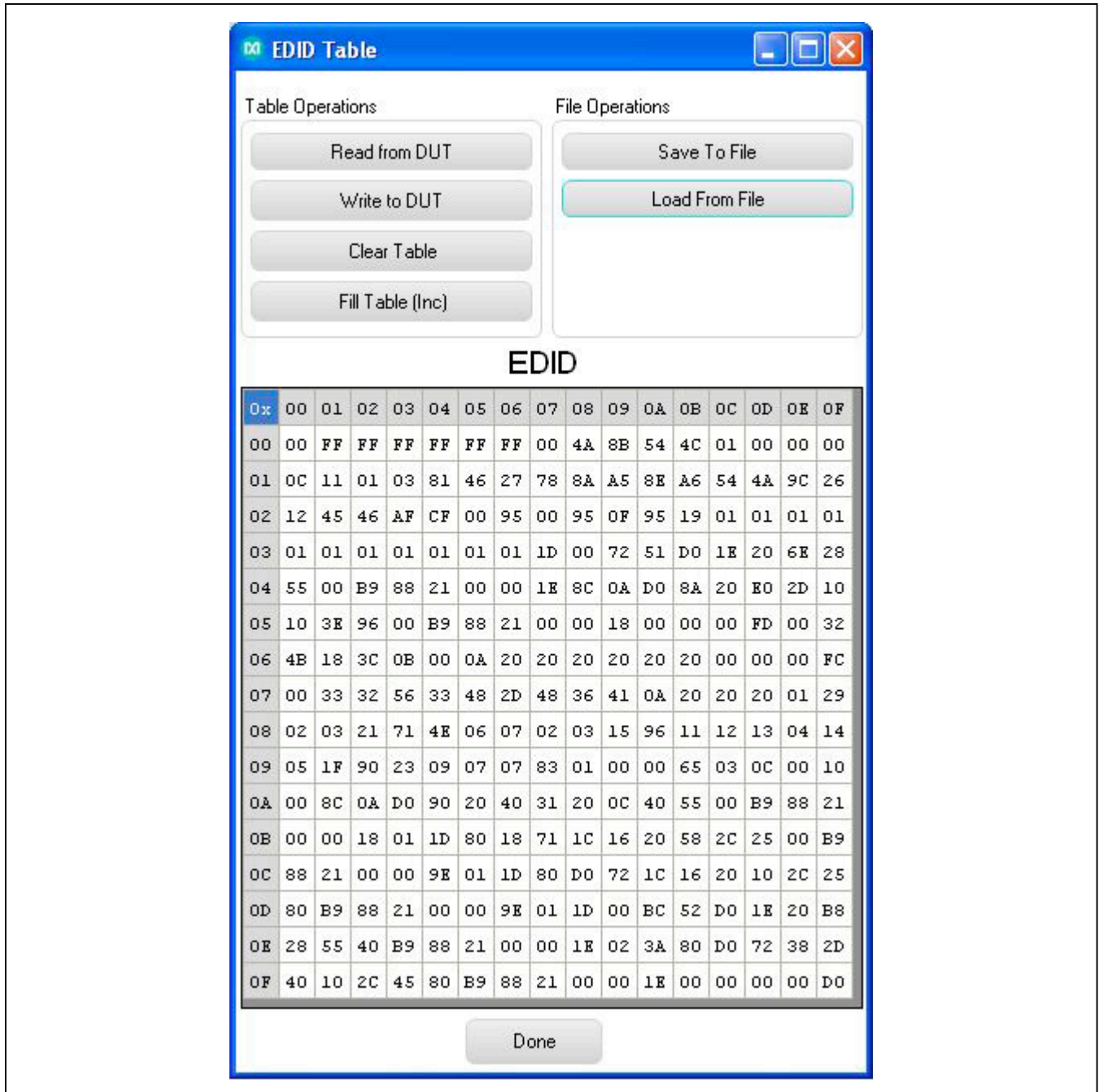

Figure 7. MAXSerDesEV-N EV Kit Software: Evaluation Kit Window (EDID Table)

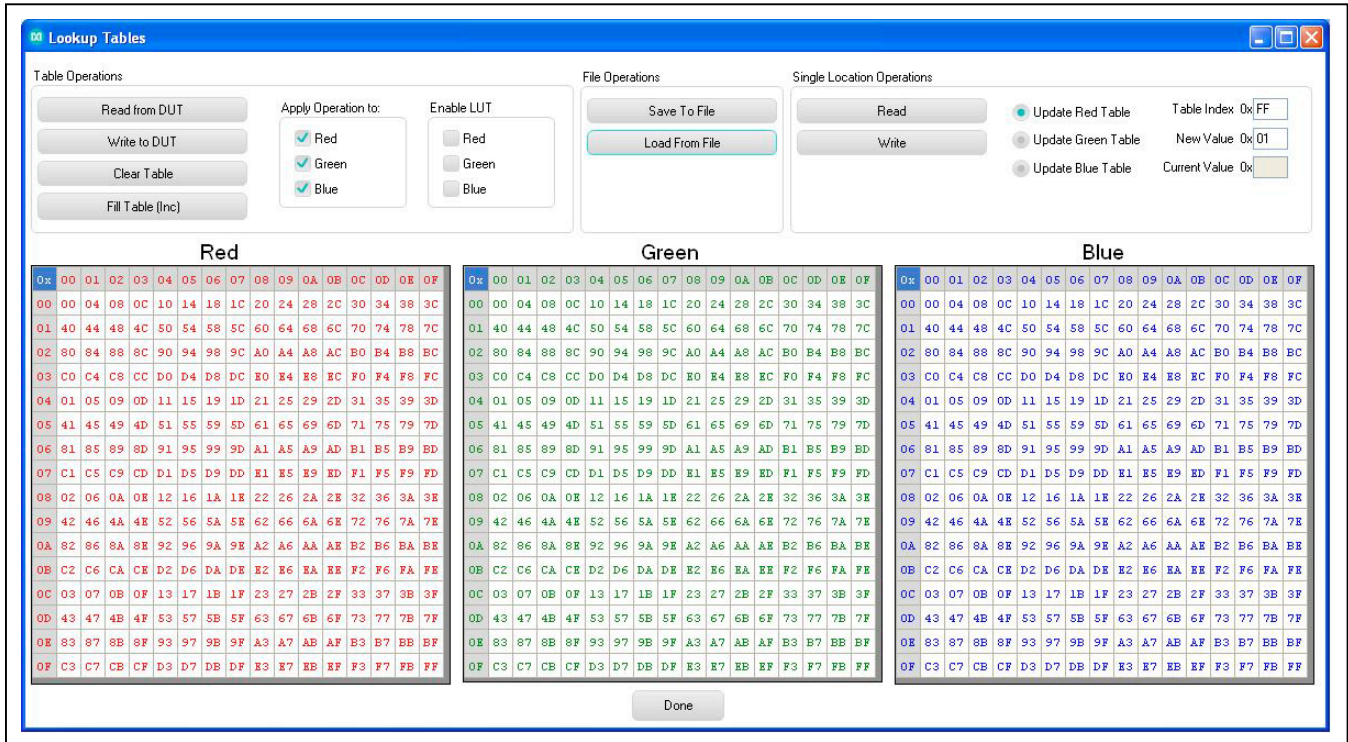

Figure 8. MAXSerDesEV-N EV Kit Software: Evaluation Kit Window (Lookup Tables)

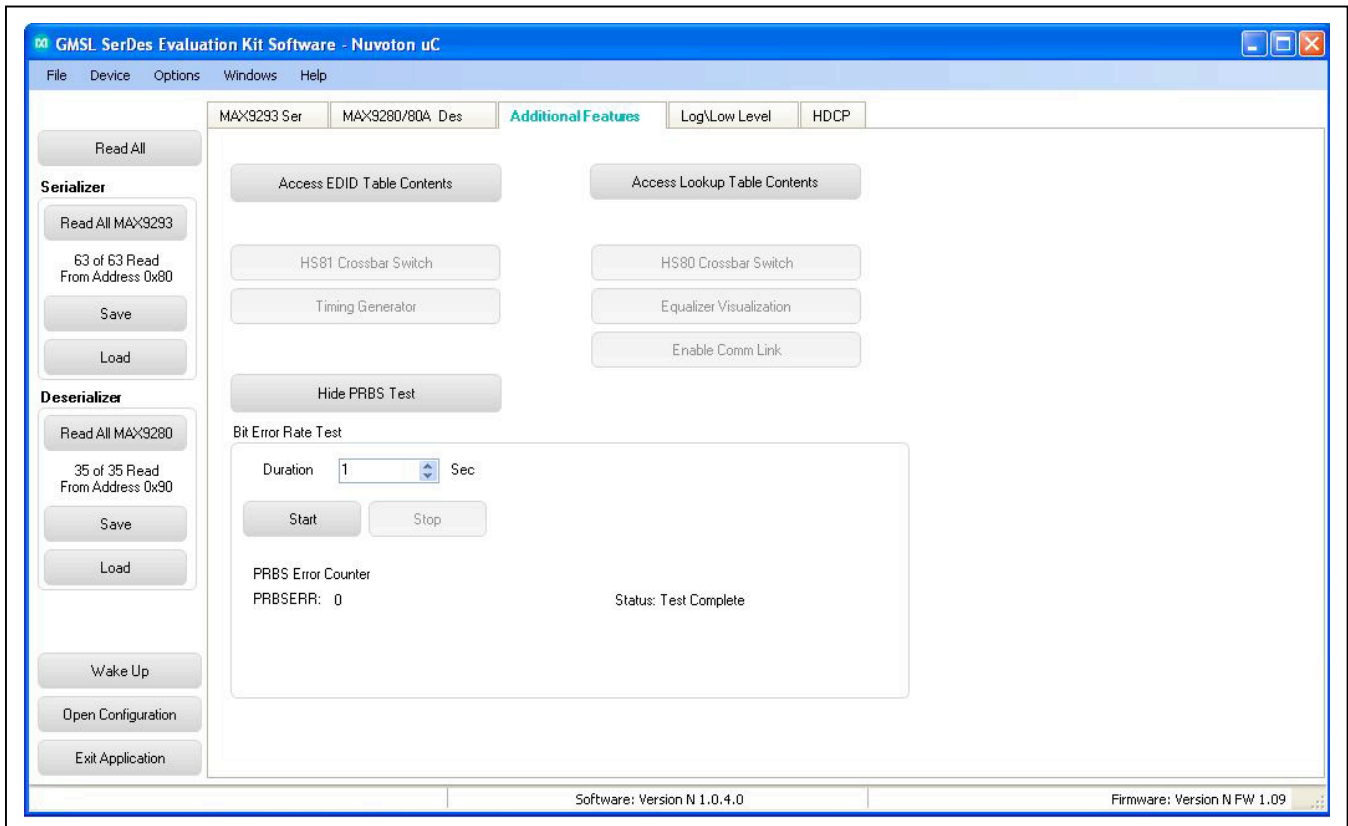

Figure 9. MAXSerDesEV-N EV Kit Software: Evaluation Kit Window (Additional Features Tab—Expanded for PRBS Test)

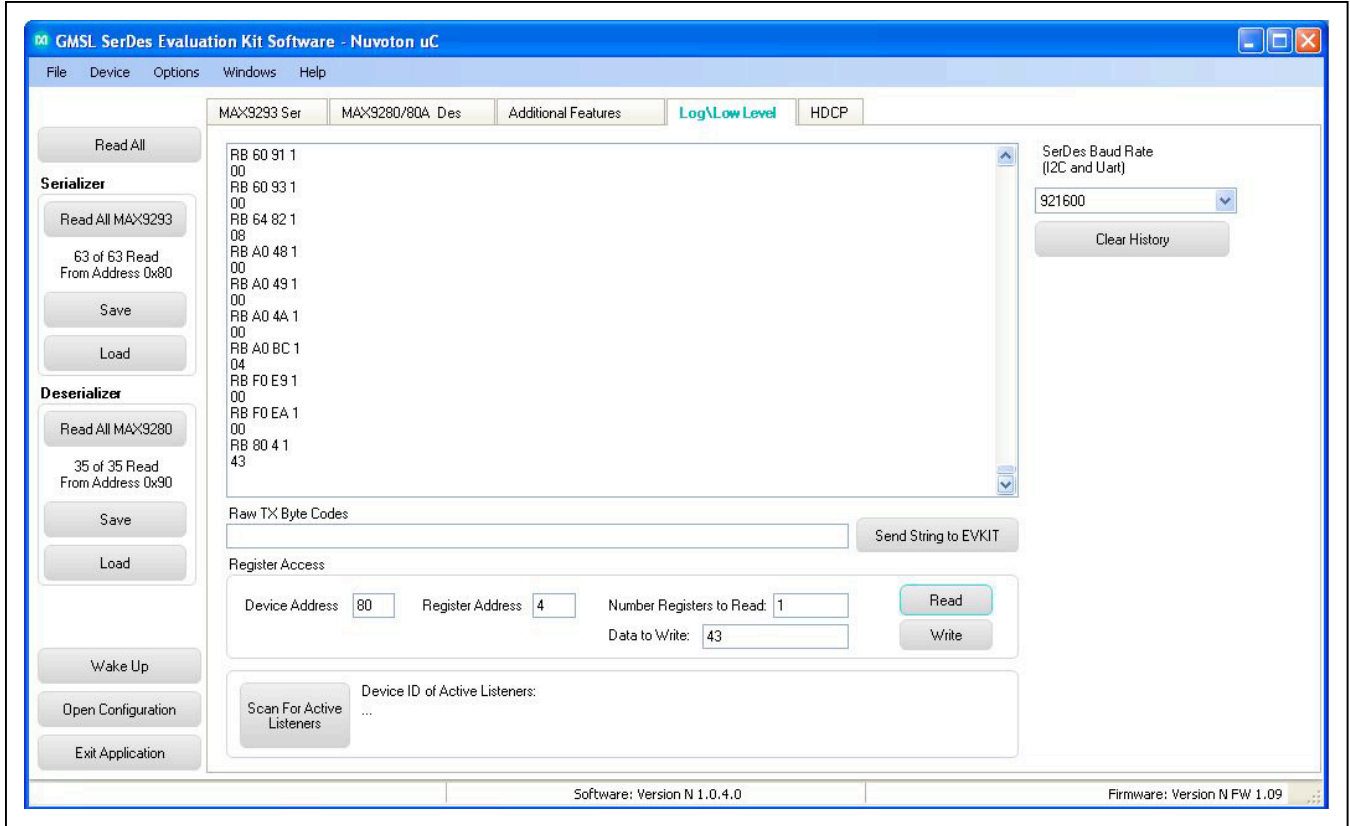

Figure 10. MAXSerDesEV-N EV KIT Software: Evaluation Kit Window (Log\Low Level Tab)

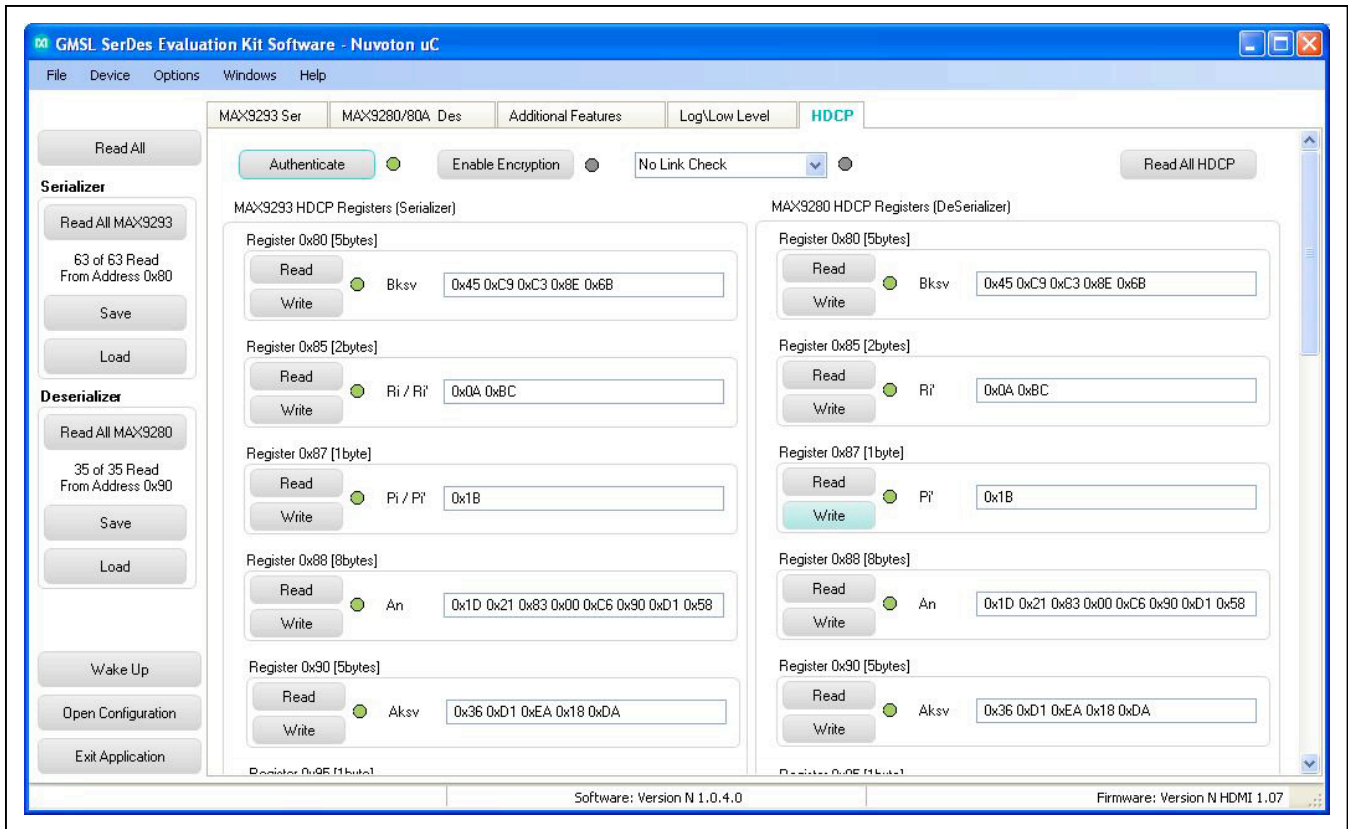

Figure 11. MAXSerDesEV-N EV Kit Software: Evaluation Kit Window (HDCP Tab)

Detailed Description of Firmware

The Nuvoton microcontroller (U12) runs a custom firmware that ensures reliable communication between the computer and DUTs. The firmware records 9-bit even-parity data received from the USB interface while RTS is set, and plays back the 9-bit data with 1.5 stop bits timing when RTS is cleared. Data received from the DUTs is immediately relayed to the USB port.

Detailed Description of Hardware

The MAX9291/MAX9293 coax EV kit provides a proven design and layout for the MAX9291/MAX9293 GMSL serializers, designed for a standard HDMI connector input and FAKRA coaxial cable serialized output. On-board level translators and an easy-to-use USB-PC connection are included on the EV kit.

The MAX9291/MAX9293 coax EV kit board consists of three principal functional blocks:

- 1) Power-supply block.
- 2) MAX9291/MAX9293 application circuit block.
- 3) Microcontrollers (U6-U10) block.

On-Board Controller

The microcontroller on the EV kit board provides the UART and I²C interface (through U6 and U10) that will communicate with both serializer and deserializer boards when they are powered on and properly configured.

Externally Applied Controller

To use the EV kit with an externally applied controller, remove shunts from the JU5 header and connect the TX/SCL signal from the external controller to the middle pin of the JU5 header. Also remove the shunt from the JU6 header and connect the RX/SDA signal from the external controller to the middle pin of the JU6 header. Connect the logic level of the external controller (VDD) to the J12.1 pin (next to the SW122 switch), labeled VREF and connect the ground signal of the external controller to the GND pin on J12.3 labeled GND.

Refer to the serializer and deserializer IC data sheets for details on read/write data formats.

Power Supplies

On-board LDO regulators (U2, U3, and U4) generate all internal voltages (AVDD, DVDD, IOVDD), including voltage levels required for the Toshiba CSI-2-to-parallel bridge-chip board from a single power source applied to the board. There are three options to power the board: USB port (default), 12V AC adapter, or 5V power supply applied on the +5VIN terminals. Jumpers VDD and JU3 select between the three power sources.

To test with AVDD, DVDD, IOVDD voltage levels different from what is generated on the board, move the corresponding shunt on headers AVDD18 (JU30), DVDD18 (JU31), RVDD18 (JU9), IOVDD (JU33), HVDD33 (JU32), PLLVDD33 (JU8), and XVDD (JU7) from pins 1-2 to pins 3-2 (next to the wire loop) and apply the external voltage to the corresponding wire-loop terminal.

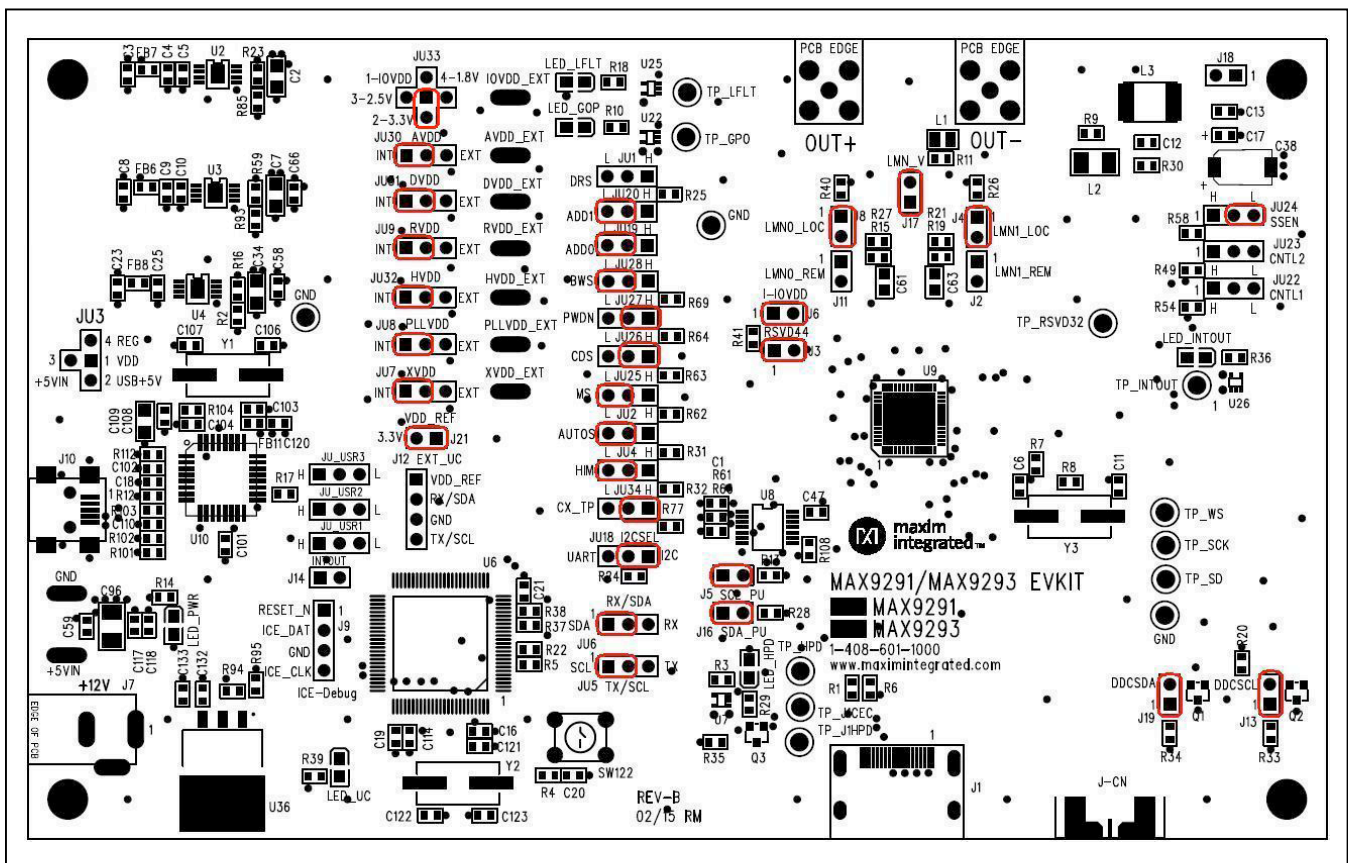

Figure 12. MAX9291/MAX9293 Coax EV Kit (Serializer Jumper Settings for Coax Link and I²C Communication)

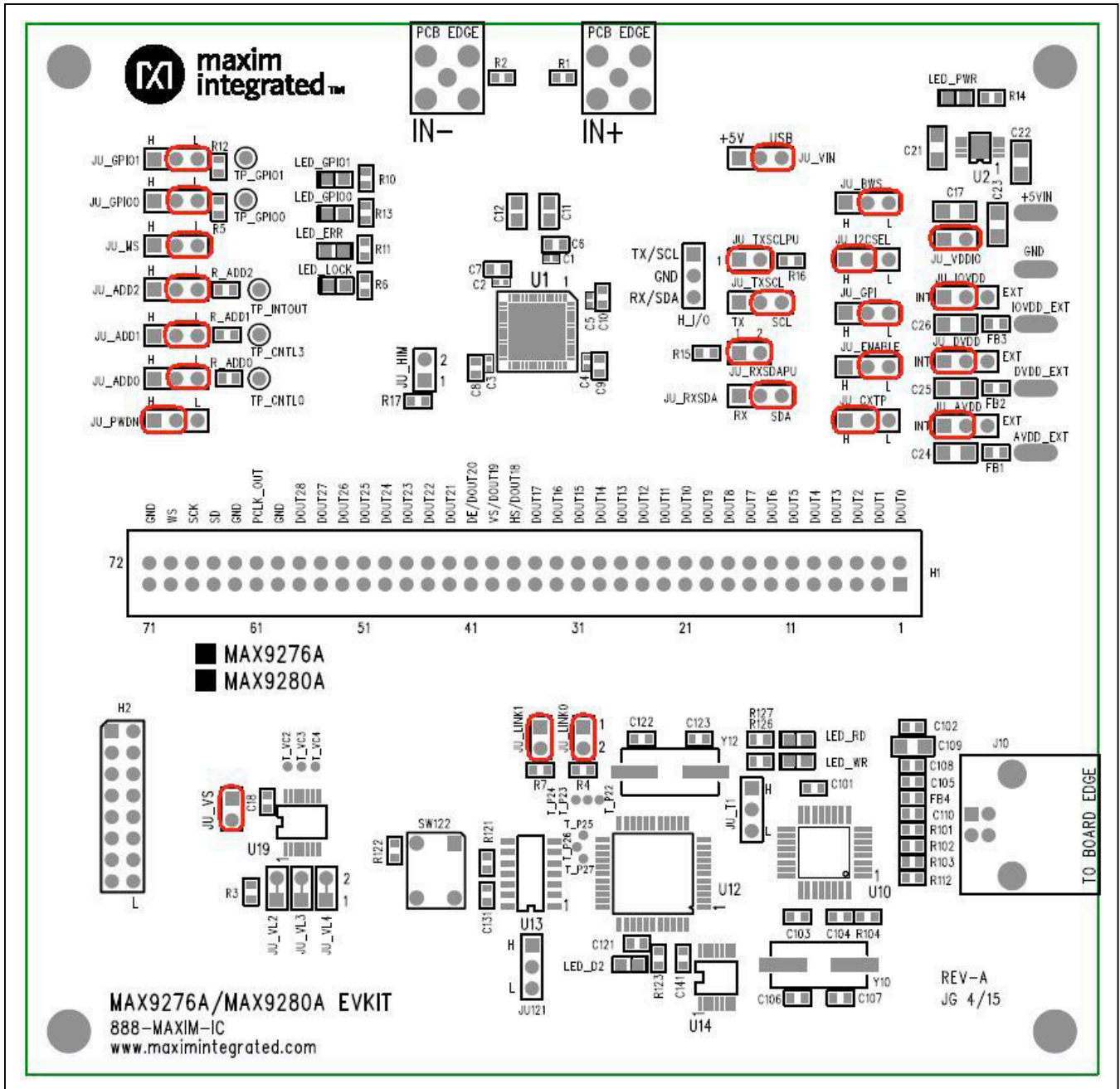

Figure 13. MAX9276A/MAX9280A Coax EV Kit (Deserializer Jumper Settings for Coax Link and I²C Communication)

Troubleshooting

Possible causes of board test failure:

- Coax cable not properly connected between OUT+ of the serializer and IN+ of the deserializer.
- PCLKIN not applied (e.g., the FG output is disabled): Verify signal at the pins on the board.
- PCLKIN, function generator output not correct: Verify signal at the pins on the board.
- Incorrect jumper setting on deserializer board: Reverify.
- Incorrect jumper setting on the Serializer board: Reverify.
- Bus selection on GUI is not consistent with jumpers' position on the boards.
- Check and verify that the USB cable has properly been connected.
- USB port has locked up: Exit the application/GUI and remove the USB cable from the board and reinsert; re-launch the GUI.
- Nuvoton µC is not communicating: Exit the application/GUI and remove the USB cable from the board and reinsert; then relaunch the GUI.
- Deserializer board is faulty: Try a different board (if available).
- Serializer board is faulty: Try a different board (if available).
- HDMI source does not detect the EV kit board: Verify that source is powered on and source output is enabled and outputting a signal.

Component Suppliers

SUPPLIER	PHONE	WEBSITE
Amphenol RF	800-627-7100	www.amphenolrf.com
Hong Kong X'tals Ltd.	852-35112388	www.hongkongcrystal.com
Murata Americas	770-436-1300	www.murataamericas.com
ON Semiconductor	602-244-6600	www.onsemi.com
Rosenberger Hochfrequenztechnik GmbH	011-49-86 84-18-0	www.rosenberger.de
TDK Corp.	847-803-6100	www.component.tdk.com

Note: Indicate that you are using the MAX9291 or MAX9293 when contacting these component suppliers.

Component List, Schematics, and PCB Layout Diagrams

Click on the links below for component list, schematics, and PCB layout diagrams:

- [MAX9291/MAX9293 EV Kit BOM](#)
- [MAX9291/MAX9293 EV Kit Schematics](#)
- [MAX9291/MAX9293 EV Kit PCB Layout](#)

Ordering Information

PART	TYPE
MAX9291COAXEVKIT#	EV Kit
MAX9293COAXEVKIT#	EV Kit
MAXCOAX2STP-HSD#	Adapter Kit

#Denotes RoHS compliant.

- Note:** The MAX9291 and MAX9293 coax EV kits are normally ordered with a companion board:
- MAX9276A coax EV kit (MAX9276ACOAXEVKIT#), or
 - MAX9280A coax EV kit (MAX9280ACOAXEVKIT#)

Revision History

REVISION NUMBER	REVISION DATE	DESCRIPTION	PAGES CHANGED
0	7/15	Initial release	—

For pricing, delivery, and ordering information, please contact Maxim Direct at 1-888-629-4642, or visit Maxim Integrated's website at www.maximintegrated.com.

Maxim Integrated cannot assume responsibility for use of any circuitry other than circuitry entirely embodied in a Maxim Integrated product. No circuit patent licenses are implied. Maxim Integrated reserves the right to change the circuitry and specifications without notice at any time.

MAX9291COAXEVMKIT# : Rev B 3/30/2015			
Component	QTY	Remarks	Manufacturer
Description	Per		Part Number
CAP0603	0	C12	
TPSV108M006R0040,1000uF	1	C38	TPSV108M006R0040
CAP-CERAMIC-0.1UF-0603,0.1uF	23	C1, C3, C5, C8, C10, C23, C25, C47, C59, C101-C104, C108, C110, C114, C117, C120-C121, C131-C132	GRM188R71H104KA93D
CAP-CERAMIC-0.22UF-0603,0.22uF	1	C13	GRM188R71E224KA88D
CAP-CERAMIC-0.22UF-0805,0.22uF	2	C61, C63	MURATA GRM21BR71H224K
CAP-CERAMIC-1000PF-0603,0.001uF	14	C24, C27, C30, C33, C37, C65, C72-C79	
CAP-CERAMIC-10UF-0603,10uF	7	C4, C9, C18, C20-C21, C118, C133	Murata GRM188R60J106M
CAP-CERAMIC-10UF-1206,10uF	4	C2, C7, C34, C109	C3216X7R1C106M160AC
CAP-CERAMIC-22PF-0603,22pF	6	C6, C11, C106-C107, C122-C123	C1608C0G1H220J080AA
CAP-CERAMIC-3.3UF-0402,3.3uF	7	C29, C32, C36, C42-C43, C53 C64	587-2236-1-ND
CAP-CERAMIC-4.7UF-0603,4.7uF	20	C16, C19, C40-C41, C44, C55-C58, C66-C71, C80-C82, C115-C116	ECJ-1VB0J475K
CAP-TACL105K006R,1uF	1	C17	TACL105K006R
CAP-TANT-10UF-1210,10uF	1	C96	Murata GRM32DC81E106KA12L
CAP0402-0.1UF,0.1uF	14	C22, C26, C28, C31, C35, C45-C46, C48-C52, C54, C62	PCC2146TR-ND
CONN-FAKRA-MALE	2	OUT+, OUT-	PE44651Z
CONN-HDMI-47151-0001	1	J1	47151-0001
CONN-HDMI-47151-0001	2	J3,J14	47151-0001
CONN_USB-MINI-1734035-1	1	J10	1734035-1
FERRITE-FILTER-CHIP-120-OHM-3A-0603	12	FB1-FB11, FB13	BLM18SG121TN1
JUMPER4	2	J9 ,J12	Molex 22-28-4363
IND-4242,330nH	1	L1	MCFT000154
IND-POWER,6.8uH	1	L2	LBC3225T6R8MR
IND-POWER,100uH	1	L3	LQH6PPN101M43
JUMPER2	13	J2-J6, J8, J11, J13, J16-J19, J21	Molex 22-28-4363
JUMPER3	22	JU1-JU2, JU4-JU9, JU18-JU20, JU22-JU28, JU30-JU32, JU34	Molex 22-28-4363
JUMPER3	0	JU_USR1-JU_USR3	Molex 22-28-4363
JUMPER-4WAY	2	, JU3, JU33	Molex 22-28-4363
LED-GREEN-0805,GREEN	1	LED_HPDP	SML-210MTT86
LED-RED-0805	5	LED_GOP, LED_INTOUT, LED_LFLT, LED_PWR, LED_UC	SML-210VTT86
N-Channel MOSFET, SOT-23-GDS	3	Q1-3	BSN20-7
MAX1792EUA33+	3	U2-U4	MAX1792EUA33
NUC140_LQFP_100,NUC140VE3CN	1	U6	NUC140VE3CN
POWER_JACK-PJ-002AH	1	J7	PJ-002AH
MAX3378EEUD+	1	U8	MAX3378EEUD+
MAX9291GTN+	1	U9	MAX9291GTN+
MAX9291GTN/V+	1	U9	MAX9291GTN/V+
FT232BL	1	U10	FT232BL
LM317MP	1	U36	LM317KTTR
MAXIMPAD	9	+5VIN, AVDD_EXT, DVDD_EXT, HVDD_EXT, IOVDD_EXT, PLLVDD_EXT, RVDD_EXT, XVDD_EXT, GND	297 SV005
RES0603,2K	3	R9, R11, R30	ANY
RES-1K-0603,1K	18	R3, R10, R14, R18, R24, R31-R32, R36, R39, R41, R49, R54, R58, R62-R64, R69, R77	CR0603-FX-1001ELF
RES0603,1M	1	R8	CR0603-JW-105GLFCT-ND
RES0603,240	1	R94	CR0603-FX-2400ELF
RES0603,31.6K	1	R1	P31.6KHCT-ND
RES0603,40.2K	1	R6	P40.2KHCT-ND
RES0603,47K	3	R20, R33-R34	P47KGTR-ND
RES0603,715	1	R95	CRCW0603715RFKEB
RES0603,909	1	R29	P909HCT-ND

RES-11K-OHM-1/10W-5%-0603-SMD,11K	1	R23	ANY
RES-1.5K-OHM-1/10W-5%-0603-SMD,1.5K	1	R103	ERJ-3GEYJ152V
RES-10K-OHM-1/10W-5%-0603-SMD,10K	6	R4, R12, R61, R66, R108, R112	ERJ-3GEYJ103V
RES-24K9-0603,24K9	3	R2, R85, R93	CRCW060324K9FKEA
RES-24K9-0603,24K9	1	R59	CRCW060324K9FKEA
RES-27-OHM-0603,27	6	R5, R22, R37-R38, R101-R102	ERJ-3GEYJ270V
RES-0-OHM-0603,DNP	0	R7	DNP
RES-30K1-0603,30K1,1%	3	R13, R28, R35	ERJ-3EKF3012V
RES-4.7K-OHM-1/10W-5%-0603-SMD,4K7	1	R17	ERJ-3GEYJ472V
RES-41K2-0603,41k2	1	R16	CRCW060341K2FKEA
RES-470-OHM-0603,470	1	R104	ERJ-3GEYJ471V
RES-49K9-0603,4.99K,1%	2	R21, R27	ERJ-3EKF4991V
RES0603/30K,30K,0.1%	1	R25	TNPW060330K0BEEA
RES0603/45K3,45K3,0.1%	2	R26, R40	ERJ-3EKF4532V
RES0603/49K9,49K9,0.1%	2	R15 ,R19	TNPW060349K9BEEA
SMA_EDGE connector	1	J-CN	142-0701-801
SW-EVQ-PAD09K	1	SW122	EVQ-PAD09K
TESTPOINT-PC5010 (red)	10	TP_GPO, TP_HPDP, TP_INTOUT, TP_J1CEC, TP_J1HPD, TP_LFLT, TP_RSVD32, TP_SCK, TP_SD, TP_WS	5000K-ND
XOR	4	U7, U22, U25-U26	74LVC1G86GW
XTAL-FQ1045A-6,6MHZ	1	Y1	FQ1045A-6
XTAL-HC-49US,12MHZ	1	Y2	300-8548-2-ND
XTAL-HC-49US,27MHZ	1	Y3	300-8571-1-ND
MAX9291/93 COAX PCB	1	PCB	

6

5

4

3

2

1

REVISION RECORD			
LTR	ECO NO.	APPROVED:	DATE:

D

D

C

C

B

B

A

A

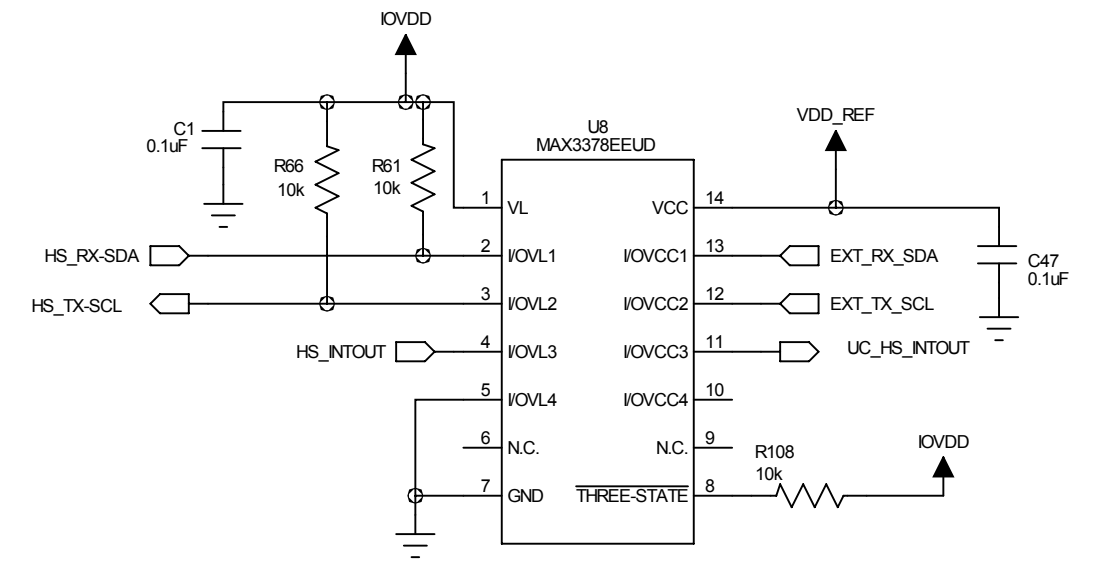
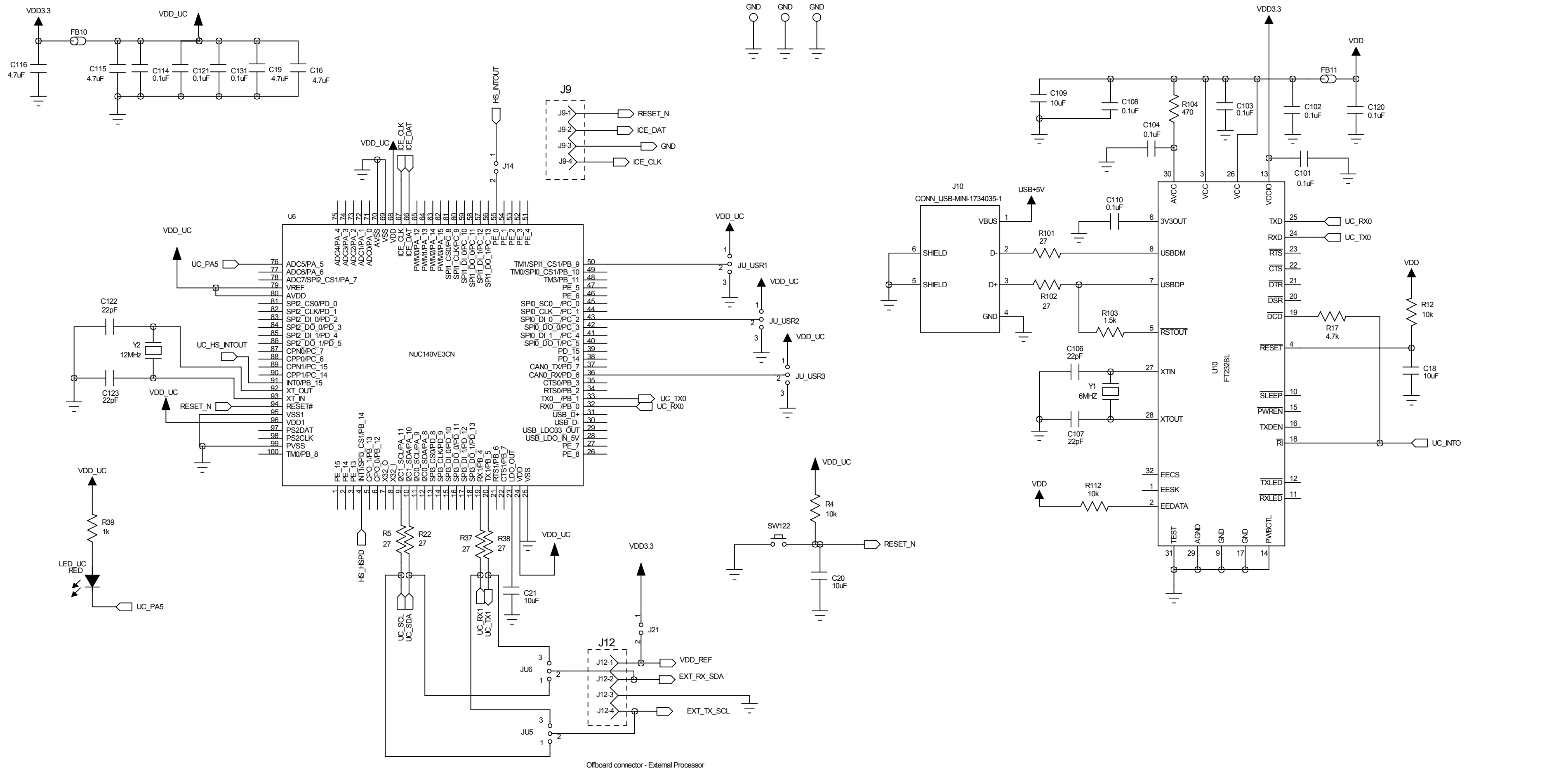



maxim integrated™

TITLE: **MAX9291/93 EVKIT**

DRAWN:	DATED: 02/18/2015	REV: B
PCB PART NUMBER:		1 of 4

6

5

4

3

2

1

REVISION RECORD			
LTR	ECO NO.	APPROVED:	DATE:

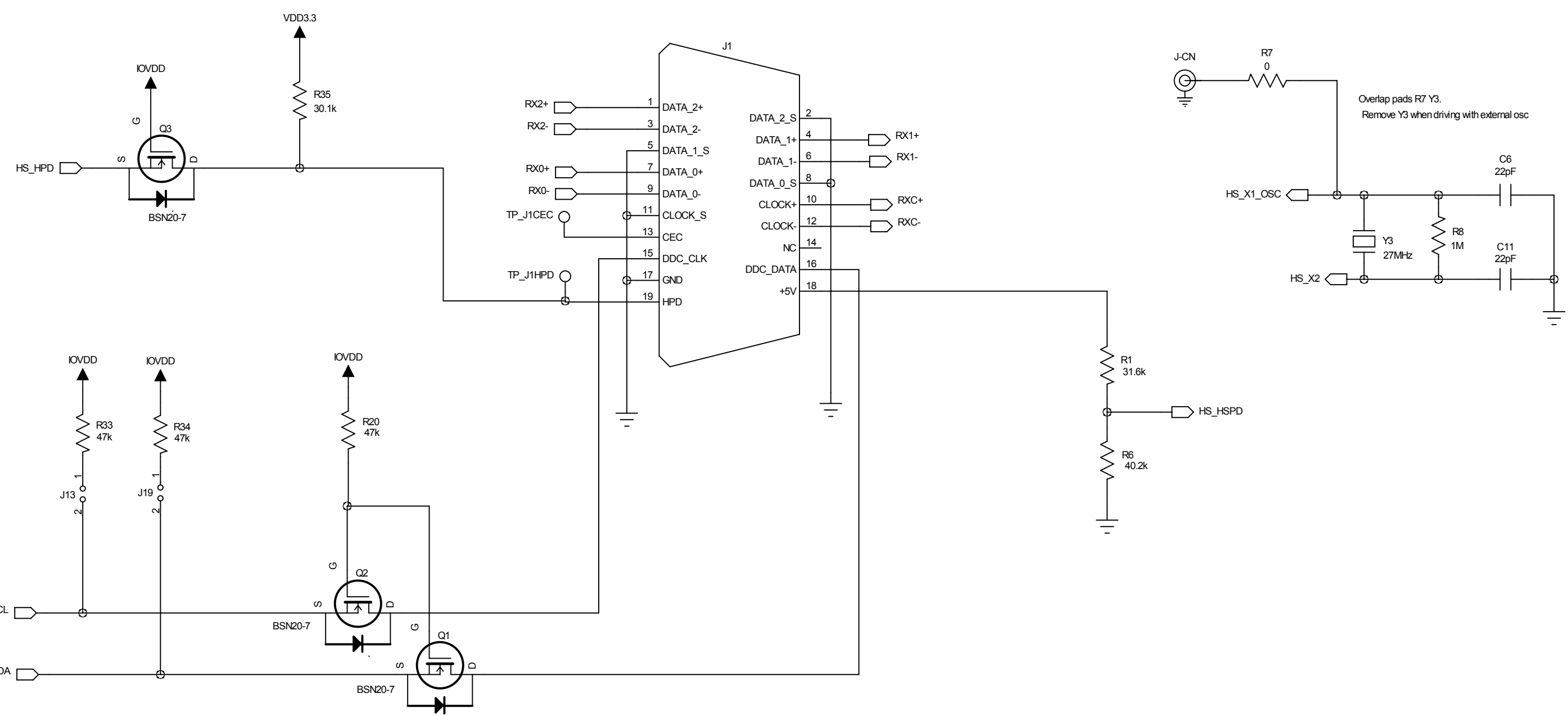

TITLE: MAX9291/93 EVKIT		
DRAWN:	PCB PART NUMBER:	REV: B
DATED: 02/18/2015	3 of 4	

6

5

4

3

2

1

REVISION RECORD			
LTR	ECO NO.	APPROVED:	DATE:

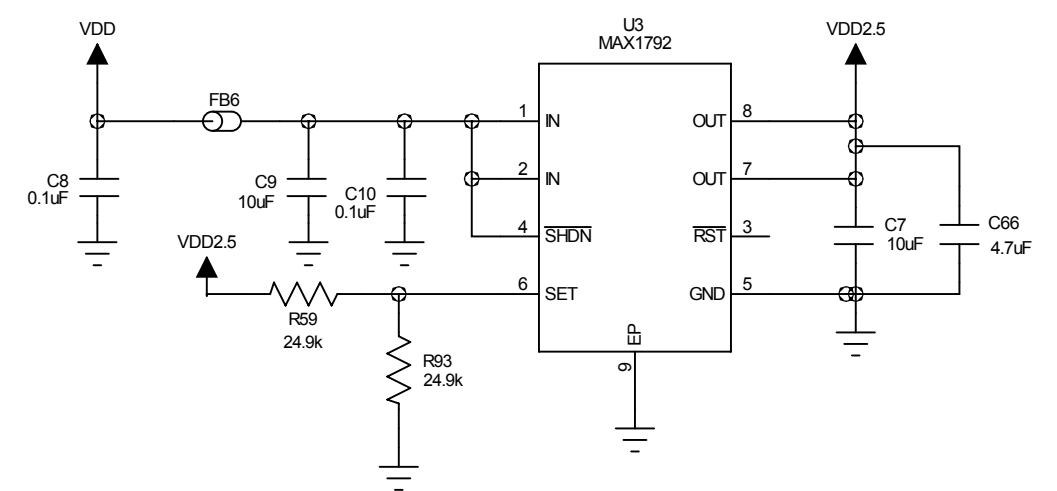
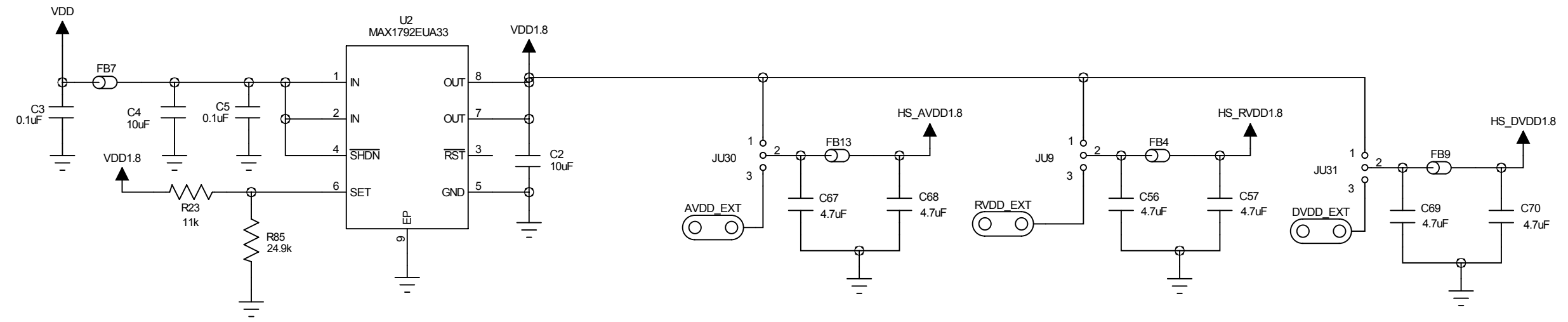
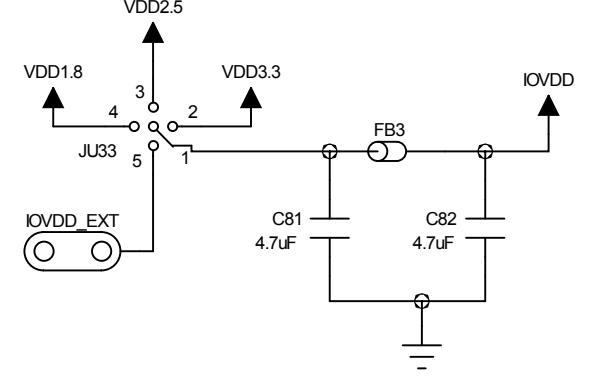
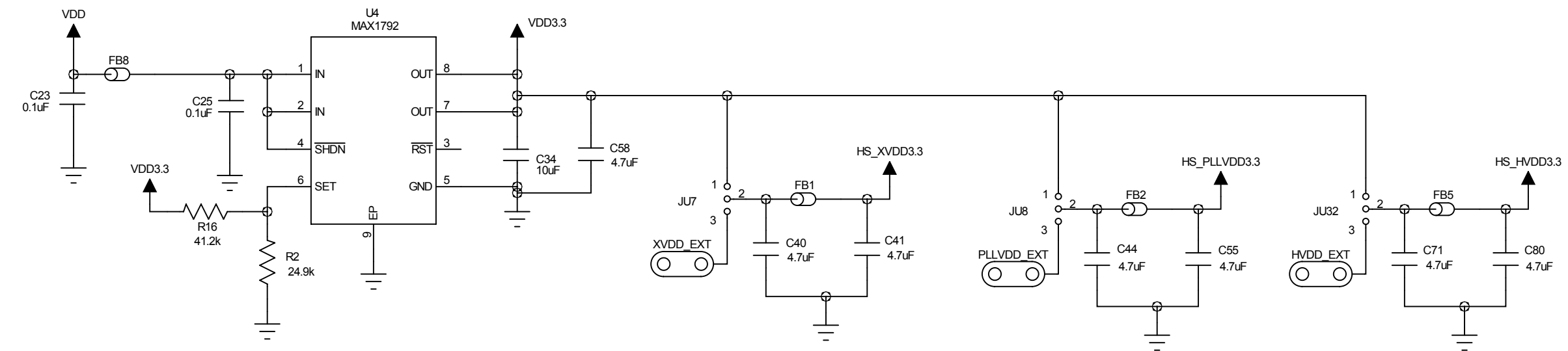
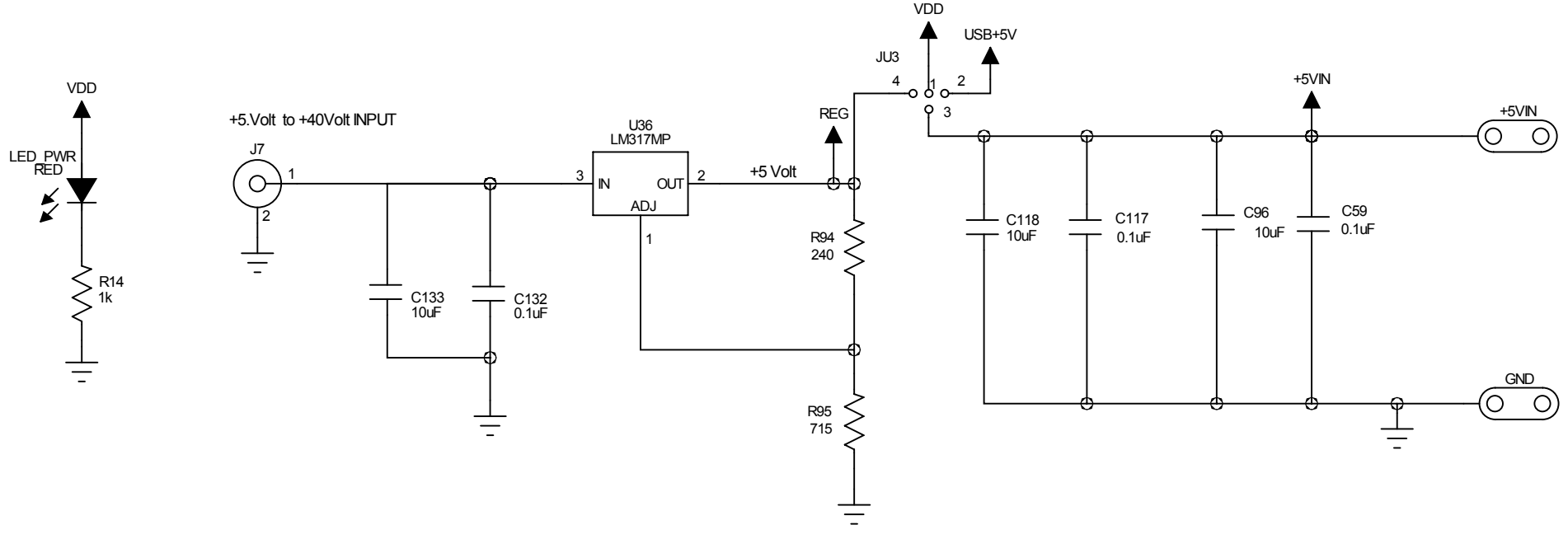

TITLE: MAX9291/93 EVKIT		
PCB PART NUMBER:		REV: B
DRAWN:	DATED: 02/18/2015	4 of 4

MAX9291/93 EV\KIT

REV
B



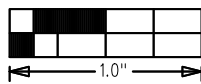
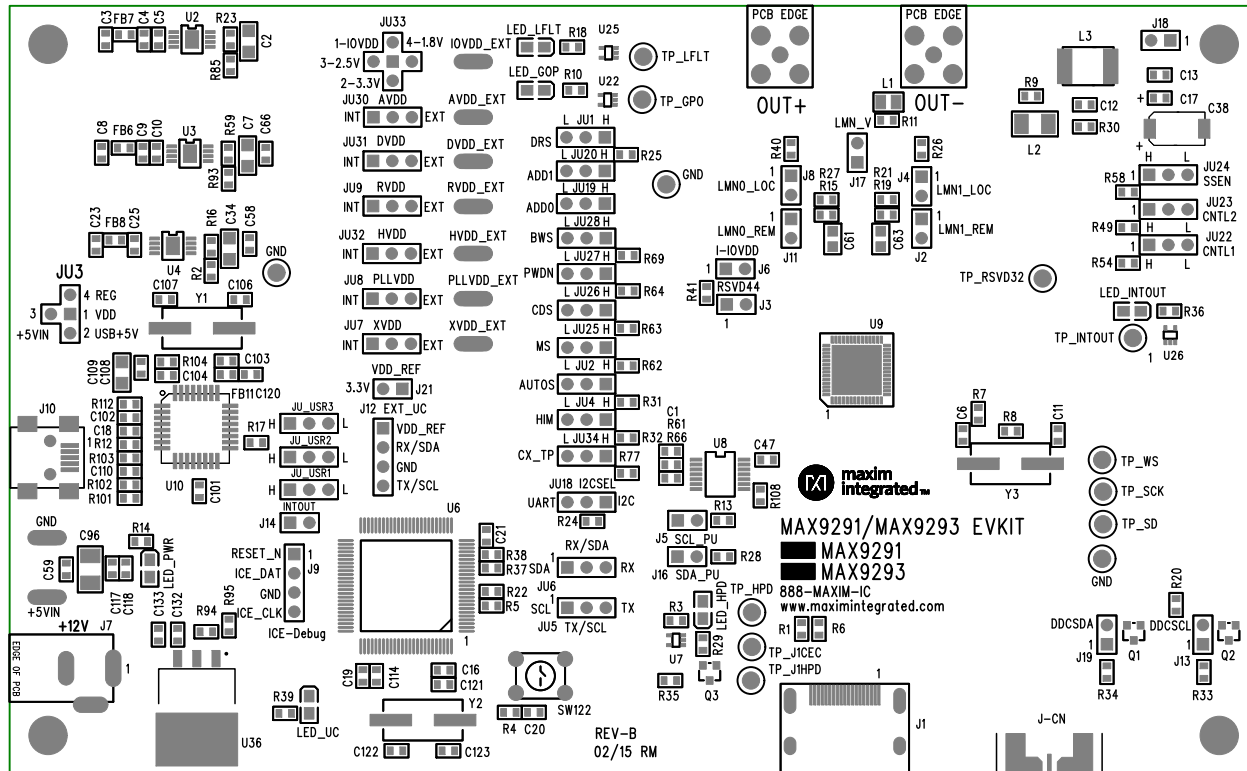

LAYER
TOP SILKSCREEN

DATE: ALL UNITS ARE IN 0.001"

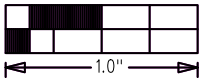
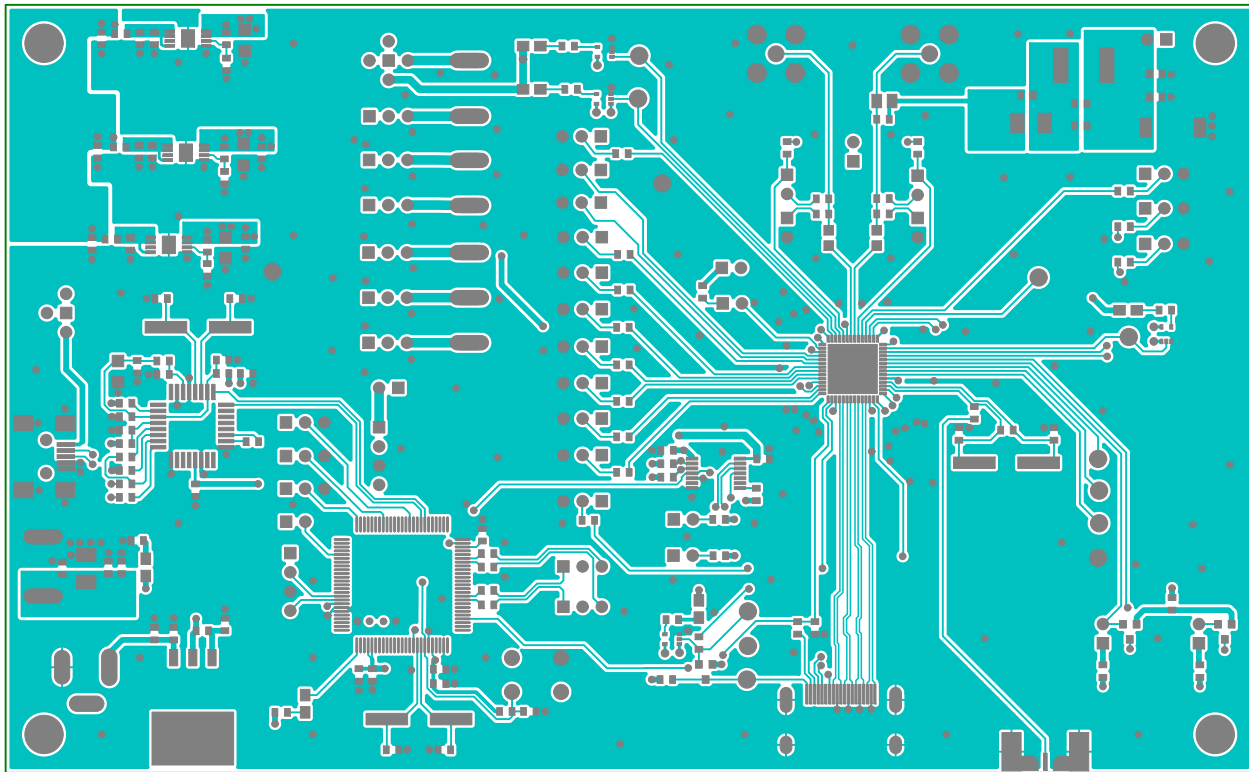

MAX9291/93 EV\KIT	
	REV B
 maxim integrated™	
LAYER	COMPONENT SIDE
DATE:	ALL UNITS ARE IN 0.001"



MAX9291/93 EV\KIT	
	REV B
 maxim integrated™	
LAYER LAYER 2 GND	
DATE:	ALL UNITS ARE IN 0.001"

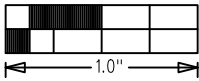
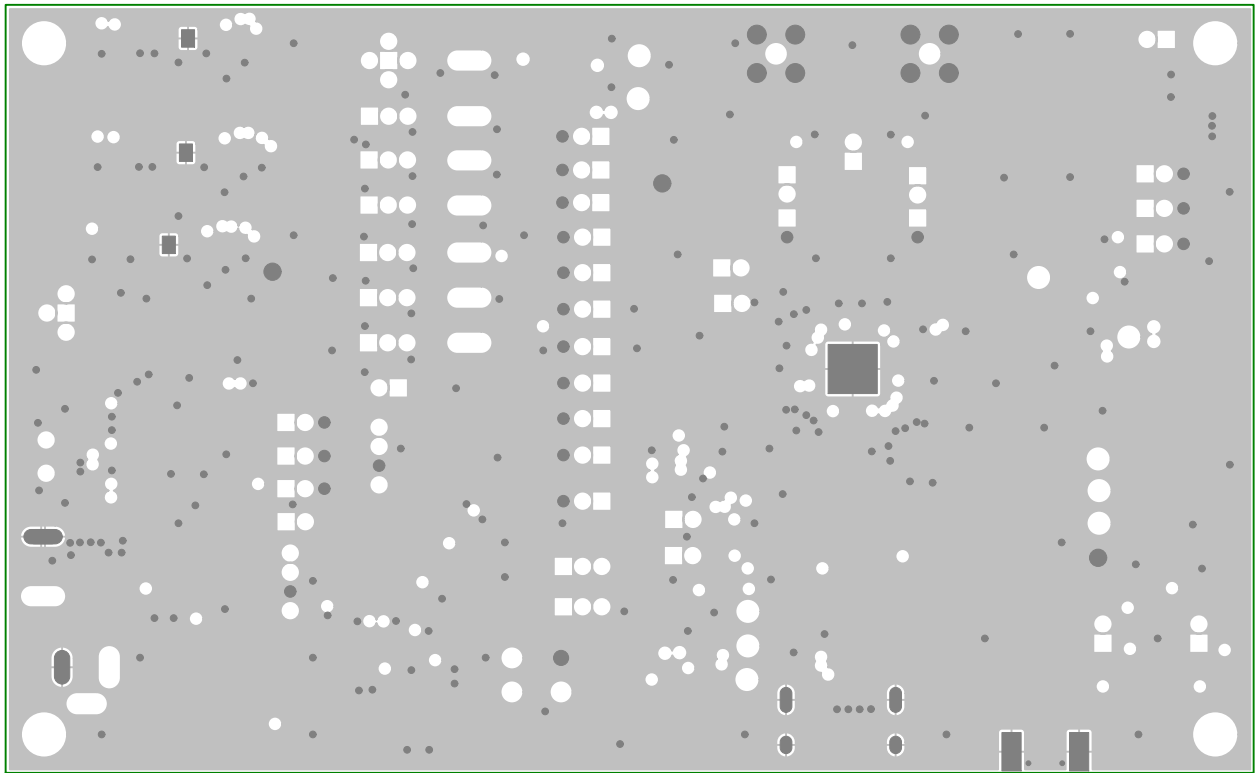

MAX9291/93 EV\KIT	
	REV B
 maxim integrated™	
LAYER	LAYER 3 PWR
DATE:	ALL UNITS ARE IN 0.001"

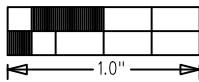
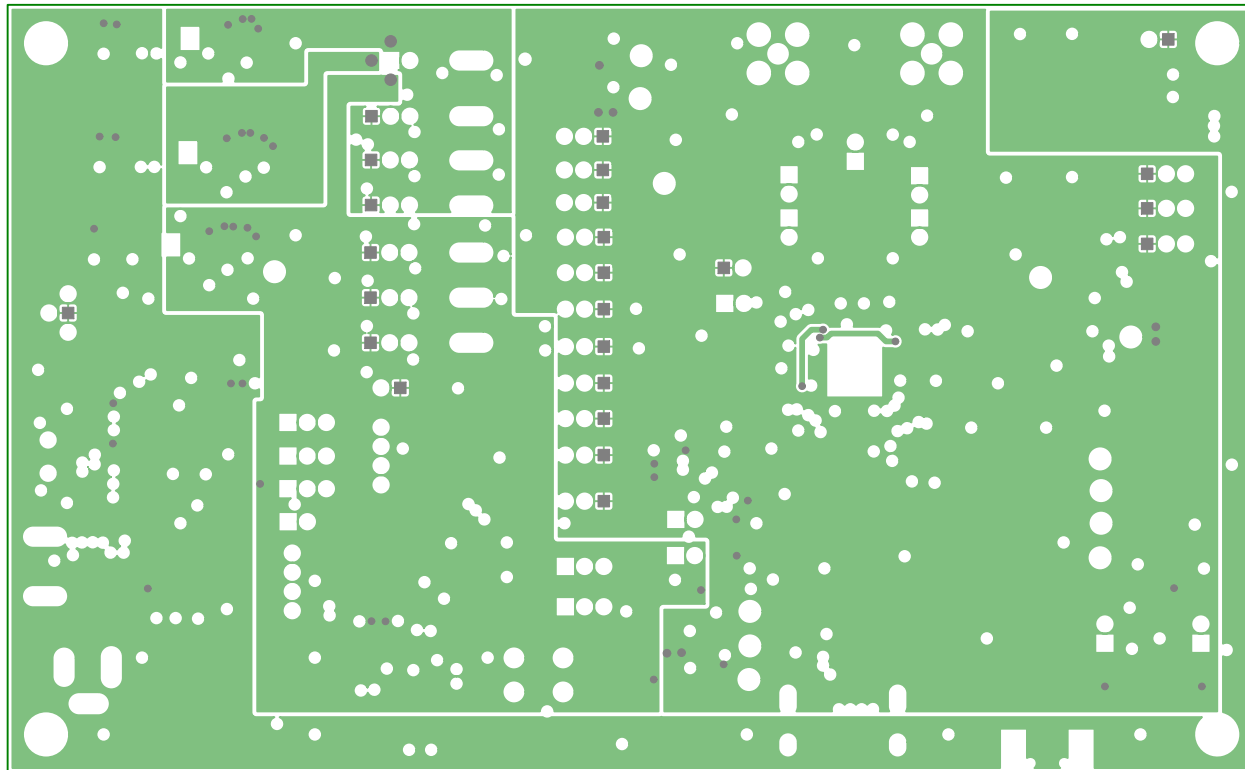

MAX9291/93 EV\KIT	
	REV B
 maxim integrated™	
LAYER	SOLDER SIDE
DATE:	ALL UNITS ARE IN 0.001"

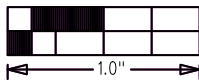
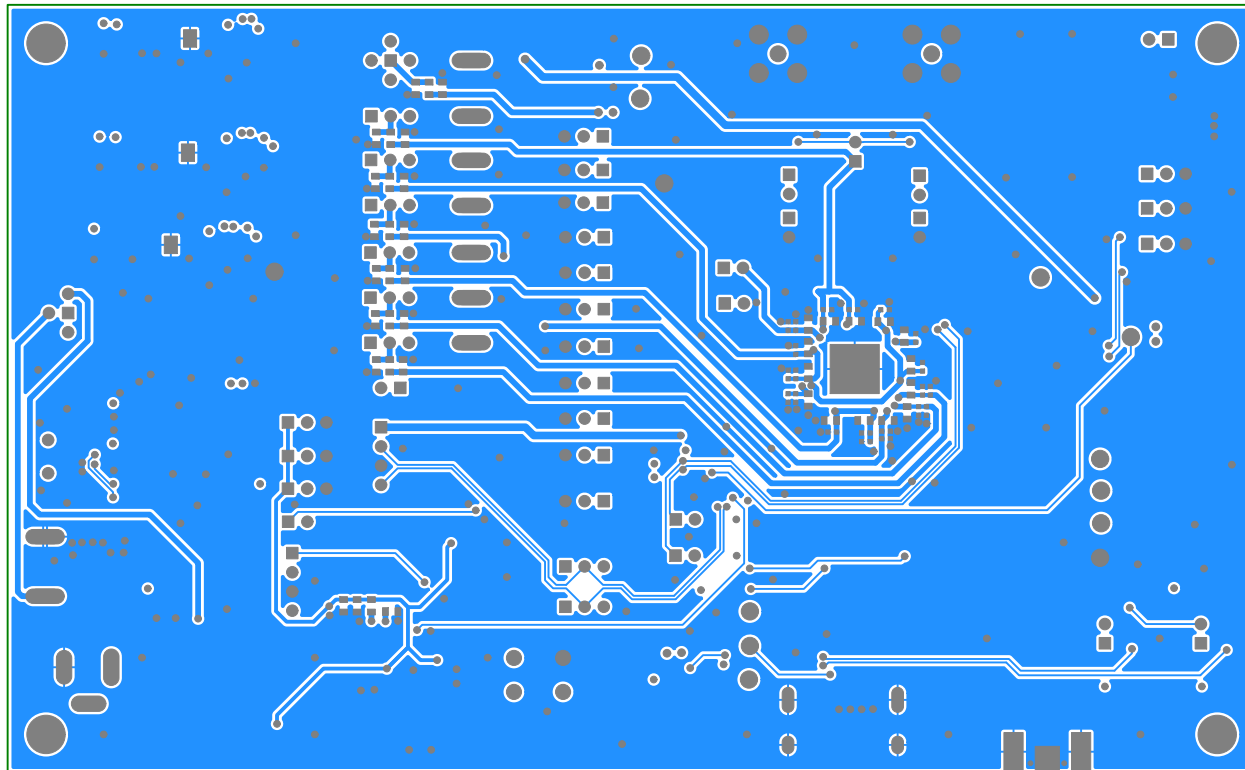

MAX9291/93 EV\KIT	
	REV B
	
LAYER BOTTOM SILKSCREEN	
DATE:	ALL UNITS ARE IN 0.001"

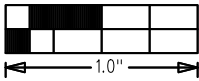
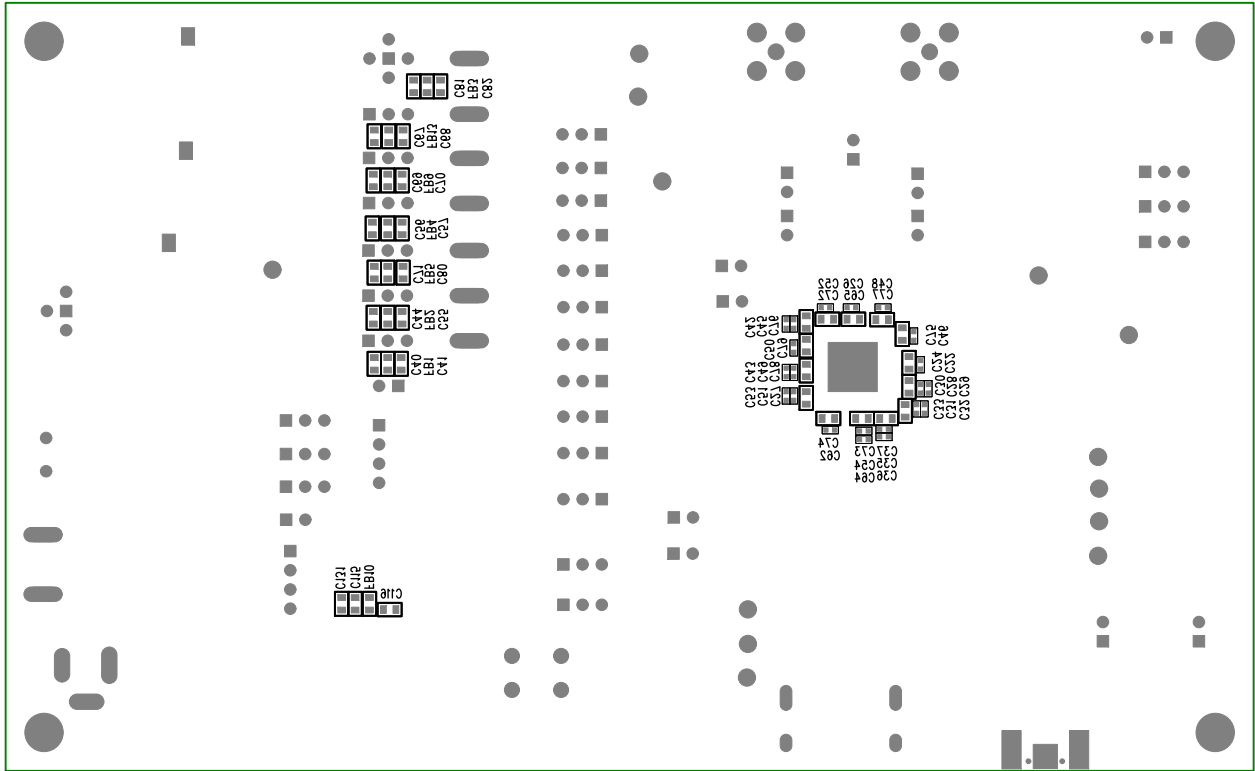

Looking for pricing, stock, or lifecycle information?

Click below to explore more details on WIN SOURCE:

- ⊖ [View MAX9286GTN+](#) on WIN SOURCE
- ⊖ [Maxim Integrated](#) Information

Optimize Your Supply Chain with WIN SOURCE Solutions

- ✓ Global Sourcing Solution
- ✓ Obsolete Management
- ✓ Cost Control Management
- ✓ Shortage Management
- ✓ Alternative Solution
- ✓ Excess Inventory Management