



**THE DATASHEET OF
SSCMNNN001PG2A3**



Installation Instructions for the TruStability® Board Mount Pressure Sensors

HSC Series – High Accuracy, Compensated/Amplified

±1.6 mbar to ±10 bar | ±160 Pa to ±1 MPa | ±0.5 inH₂O to ±150 psi
Digital or Analog Output

SSC Series – Standard Accuracy, Compensated/Amplified

±1.6 mbar to ±10 bar | ±160 Pa to ±1 MPa | ±0.5 inH₂O to ±150 psi
Digital or Analog Output

GENERAL INFORMATION

Honeywell's TruStability® High Accuracy Silicon Ceramic (HSC) Series and Standard Accuracy Silicon Ceramic (SSC) Series are piezoresistive silicon pressure sensors offering a digital or analog output for reading pressure over the specified full scale pressure span and temperature range.

These sensors measure absolute, gage, or differential pressures. The absolute versions have an internal vacuum reference and an output value proportional to absolute pressure. Gage versions are referenced to atmospheric pressure and provide an output proportional to pressure variations from atmosphere. Differential versions allow measurement of pressure between the two pressure ports.

The HSC Series is calibrated over the temperature range of 0 °C to 50 °C [32 °F to 122 °F] while the SSC Series is calibrated over the temperature range of -20 °C to 85 °C [-4 °F to 185 °F].

The TruStability® pressure sensors are intended for use with non-corrosive, non-ionic gases, such as air and other dry gases. An available option extends the performance of these sensors to non-corrosive, non-ionic liquids for pressure ranges above 40 mbar | 4 kPa | 20 inH₂O.

CLEANING

CAUTION

IMPROPER CLEANING

Avoid cleaning the sensor; however, if it must be cleaned ensure cleaning fluids, such as appropriate alcohols or fluorinated solvents, are used based on the type of contaminants to be removed. Do not immerse the sensor. **Failure to comply with these instructions may result in product damage.**

CAUTION

PRODUCT DAMAGE FOR SENSORS WITH LIQUID MEDIA OPTION (ONLY AVAILABLE 60 MBAR | 6 KPA | 1 PSI AND ABOVE)

- Ensure liquid media is applied to Port 1 only; Port 2 is not compatible with liquids.
- Ensure liquid media contains no particulates. All TruStability® sensors are dead-ended devices. Particulates can accumulate inside the sensor, causing damage or affecting sensor output.
- Recommend that the sensor be positioned with Port 1 facing downwards; any particulates in the system are less likely to enter and settle within the pressure sensor if it is in this position.
- Ensure liquid media does not create a residue when dried; build-up inside the sensor may affect sensor output. Rinsing of a dead-ended sensor is difficult and has limited effectiveness for removing residue.
- Ensure liquid media are compatible with wetted materials. Noncompatible liquid media will degrade sensor performance and may lead to sensor failure.

Failure to comply with these instructions may result in product damage.

Table 1. Absolute Maximum Ratings¹

Characteristic	Min.	Max.	Unit
Supply voltage (V_{supply}) ² :	-3.0	6.0	Vdc
Storage temperature	-40 [-40]	85 [185]	°C [°F]
Soldering time and temperature:			
lead solder temperature (SIP, DIP)	4 s max. at 250 °C [482 °F]		
peak reflow temperature (SMT)	15 s max. at 250 °C [482 °F]		

¹ Absolute maximum ratings are the extreme limits the device will withstand without damage.

² Incorrect application of supply voltage or ground to the wrong pin may cause electrical failure.

Table 2. Environmental Specifications

Characteristic	Parameter
Humidity: gases only (See “Options N and D” in Figures 5 and 6.) liquid media (See “Options T and V” in Figures 5 and 6.)	0% to 95% RH, non-condensing 100% condensing or direct liquid media on Port 1
Vibration	MIL-STD-202G Method 204D, Condition B (15 g, 10 Hz to 2 Hz)
Shock	MIL-STD-202G, Method 213B, Condition C (100 g, 6 ms duration)
Life ¹	1 million pressure cycles minimum
Solder reflow	J-STD-020-D.1 Moisture Sensitivity Level 1 (unlimited shelf life when stored at ≤30 °C/85 % RH)

¹Life may vary depending on specific application in which sensor is utilized.

Table 3. Wetted Materials¹

Component	Port 1 (Pressure Port)	Port 2 (Reference Port)
Ports and covers	high temperature polyamide	high temperature polyamide
Substrate	alumina ceramic	alumina ceramic
Adhesives	epoxy, silicone	epoxy, silicone
Electronic components	ceramic, silicon, glass, solder	silicon, glass, gold

¹Contact Honeywell Customer Service for detailed material information.

Table 4. HSC Series and SSC Series Analog Operating Specifications

Characteristic	Min.	Typ.	Max.	Unit
Supply voltage (V_{supply}) ^{1, 2, 3} : pressure ranges ≥60 mbar 6 kPa 1 psi: 3.3 Vdc 5.0 Vdc pressure ranges ≤40 mbar 4 kPa 20 inH ₂ O: 3.3 Vdc 5.0 Vdc	3.0 4.75 3.27 4.95	3.3 5.0 3.3 5.0	3.6 5.25 3.33 5.05	Vdc
Supply current: 3.3 Vdc 5.0 Vdc	— —	2.1 2.7	2.8 3.5	mA
Operating temperature range ⁴ : HSC SSC	-20 [-4] -40 [-40]	— —	85 [185] 85 [185]	°C [°F]
Compensated temperature range ⁵ : HSC SSC	0 [-32] -20 [-4]	— —	50 [122] 85 [185]	°C [°F]
Startup time (power up to data ready)	—	—	5	ms
Response time	—	1	—	ms
Clipping limit: upper lower	— 2.5	— —	97.5 —	%Vsupply
Accuracy ⁶	—	—	±0.25	%FSS BFSL ⁸
Output resolution	0.03	—	—	%FSS
Orientation sensitivity (± 1 g) ^{7, 9} : pressure ranges ≤40 mbar 4 kPa 20 inH ₂ O: pressure ranges ≤2.5 mbar 250 Pa 1 inH ₂ O:	— —	±0.1 ±0.2	— —	%FSS

¹Sensors are either 3.3 Vdc or 5.0 Vdc based on the catalog listing selected.

²Ratiometricity of the sensor (the ability of the device output to scale to the supply voltage) is achieved within the specified operating voltage.

³The sensor is not reverse polarity protected. Incorrect application of supply voltage or ground to the wrong pin may cause electrical failure.

⁴Operating temperature range: The temperature range over which the sensor will produce an output proportional to pressure.

⁵Compensated temperature range: The temperature range over which the sensor will produce an output proportional to pressure within the specified performance limits.

⁶Accuracy: The maximum deviation in output from a Best Fit Straight Line (BFSL) fitted to the output measured over the pressure range at 25 °C [77 °F]. Includes all errors due to pressure non-linearity, pressure hysteresis, and non-repeatability.

⁷Orientation sensitivity: The maximum change in offset of the sensor due to a change in position or orientation relative to Earth’s gravitational field.

⁸Full Scale Span (FSS): The algebraic difference between the output signal measured at the maximum (Pmax.) and minimum (Pmin.) limits of the pressure range. (See Figures 5 and 6 for ranges.)

⁹Insignificant for pressure ranges above 40 mbar | 4 kPa | 20 inH₂O.

HSC Series – High Accuracy, Compensated/Amplified

SSC Series – Standard Accuracy, Compensated/Amplified

Issue F
50044171

Table 5. HSC Series and SSC Series Digital Operating Specifications

Characteristic	Min.	Typ.	Max.	Unit
Supply voltage (V_{supply}) ^{1, 2, 3} :				
pressure ranges ≥ 60 mbar 6 kPa 1 psi:				Vdc
3.3 Vdc	3.0	3.3	3.6	
5.0 Vdc	4.75	5.0	5.25	
pressure ranges ≤ 40 mbar 4 kPa 20 inH ₂ O:				Vdc
3.3 Vdc	3.27	3.3	3.33	
5.0 Vdc	4.95	5.0	5.05	
Supply current:				mA
3.3 Vdc	—	3.1	3.9	
5.0 Vdc	—	3.7	4.6	
Operating temperature range ⁴ :				°C [°F]
HSC	-20 [-4]	—	85 [185]	
SSC	-40 [-40]	—	85 [185]	
Compensated temperature range ⁵ :				°C [°F]
HSC	0 [-32]	—	50 [122]	
SSC	-20 [-4]	—	85 [185]	
Startup time (power up to data ready)	—	—	3	ms
Response time	—	0.46	—	ms
SPI/I ² C voltage level:				%Vsupply
low	—	—	20	
high	80	—	—	
Pull up on SDA/MISO, SCL/SCLK, SS	1	—	—	kOhm
Accuracy ⁶	—	—	± 0.25	%FSS BFSL ⁸
Output resolution	12	—	—	bits
Orientation sensitivity (± 1 g) ^{7, 9} :				%FSS
pressure ranges ≤ 40 mbar 4 kPa 20 inH ₂ O:	—	± 0.1	—	
pressure ranges ≤ 2.5 mbar 250 Pa 1 inH ₂ O:	—	± 0.2	—	

¹Sensors are either 3.3 Vdc or 5.0 Vdc based on the catalog listing selected.

²Ratiometricity of the sensor (the ability of the device output to scale to the supply voltage) is achieved within the specified operating voltage.

³The sensor is not reverse polarity protected. Incorrect application of supply voltage or ground to the wrong pin may cause electrical failure.

⁴Operating temperature range: The temperature range over which the sensor will produce an output proportional to pressure.

⁵Compensated temperature range: The temperature range over which the sensor will produce an output proportional to pressure within the specified performance limits.

⁶Accuracy: The maximum deviation in output from a Best Fit Straight Line (BFSL) fitted to the output measured over the pressure range at 25 °C [77 °F]. Includes all errors due to pressure non-linearity, pressure hysteresis, and non-repeatability.

⁷Orientation sensitivity: The maximum change in offset of the sensor due to a change in position or orientation relative to Earth's gravitational field.

⁸Full Scale Span (FSS): The algebraic difference between the output signal measured at the maximum (Pmax.) and minimum (Pmin.) limits of the pressure range. (See Figures 5 and 6 for ranges.)

⁹Insignificant for pressure ranges above 40 mbar | 4 kPa | 20 inH₂O.

HSC Series—High Accuracy, Compensated/Amplified
SSC Series—Standard Accuracy, Compensated/Amplified

Issue F
50044171

Figure 1. DIP Package Dimensional Drawings (For reference only: mm [in])

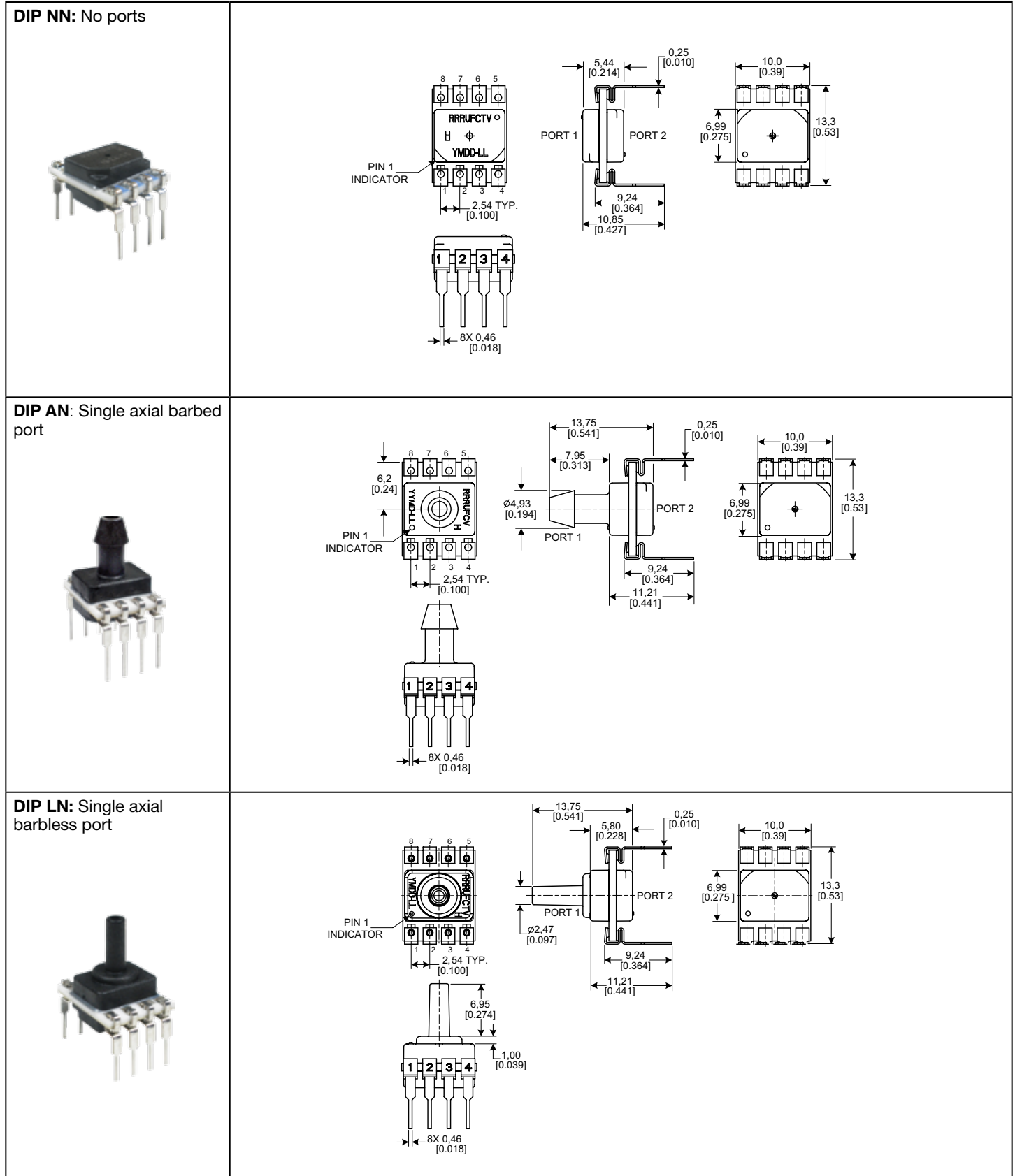
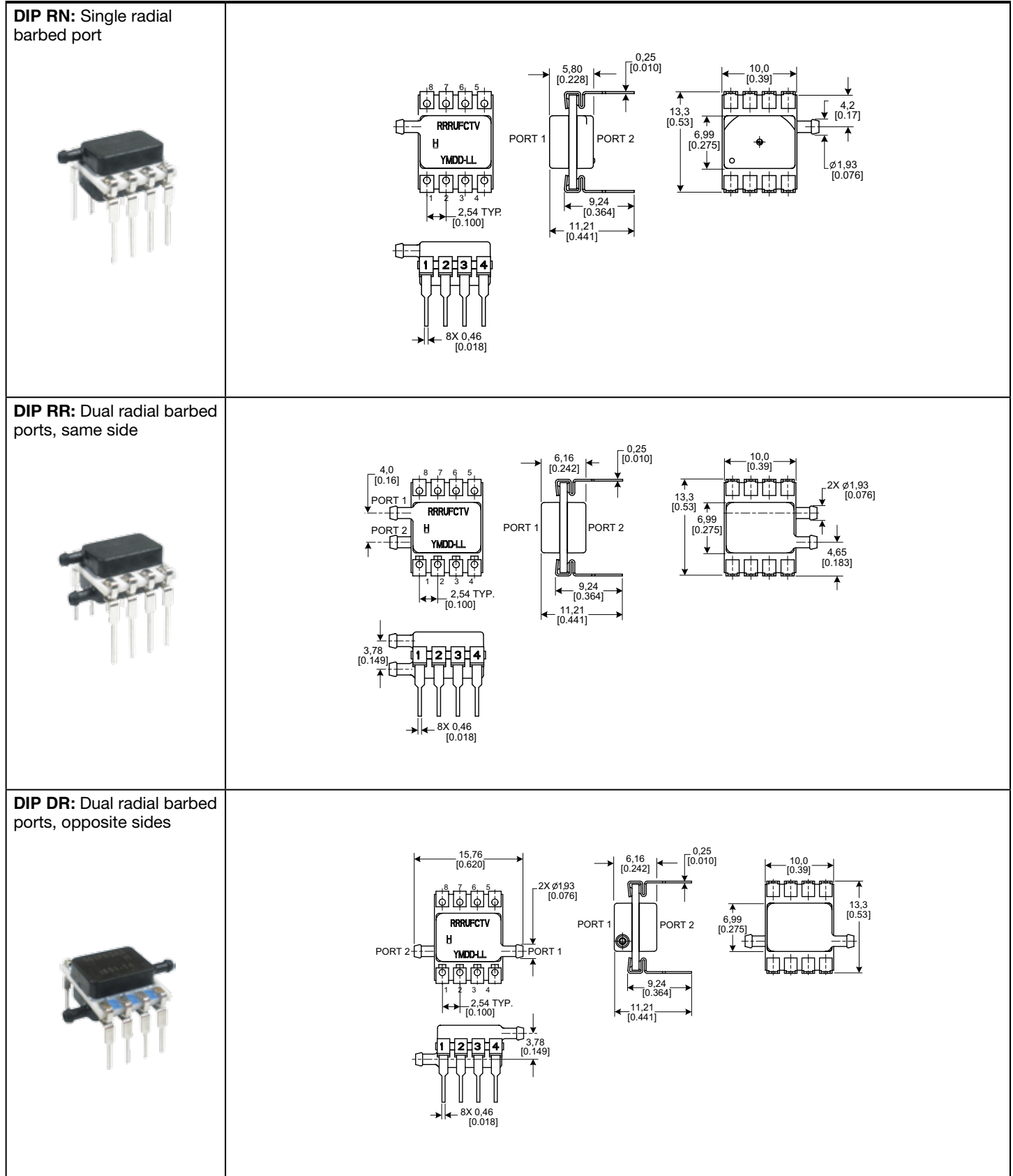


Figure 1. DIP Package Dimensional Drawings (continued)



HSC Series—High Accuracy, Compensated/Amplified
SSC Series—Standard Accuracy, Compensated/Amplified

Issue F

50044171

Figure 1. DIP Package Dimensional Drawings (continued)

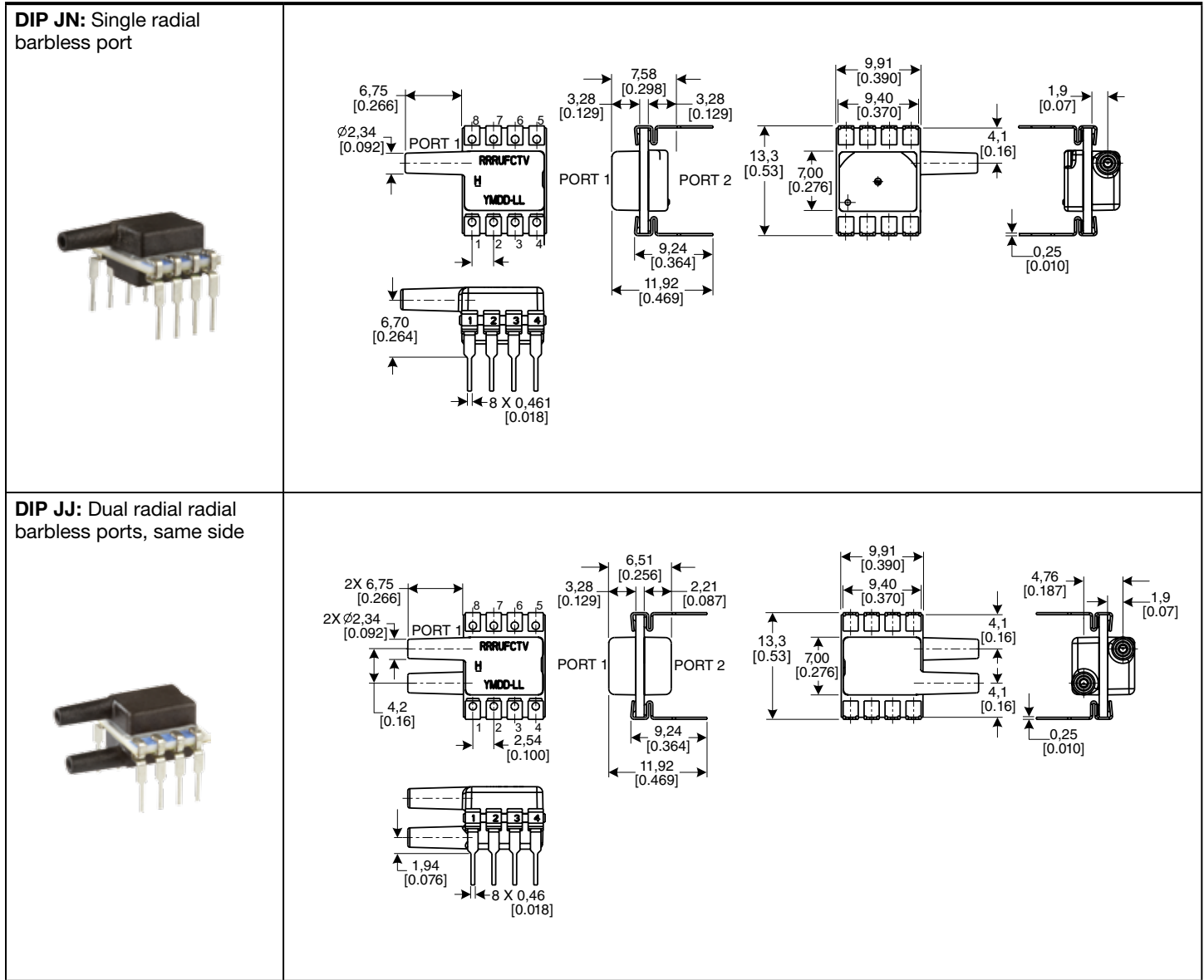
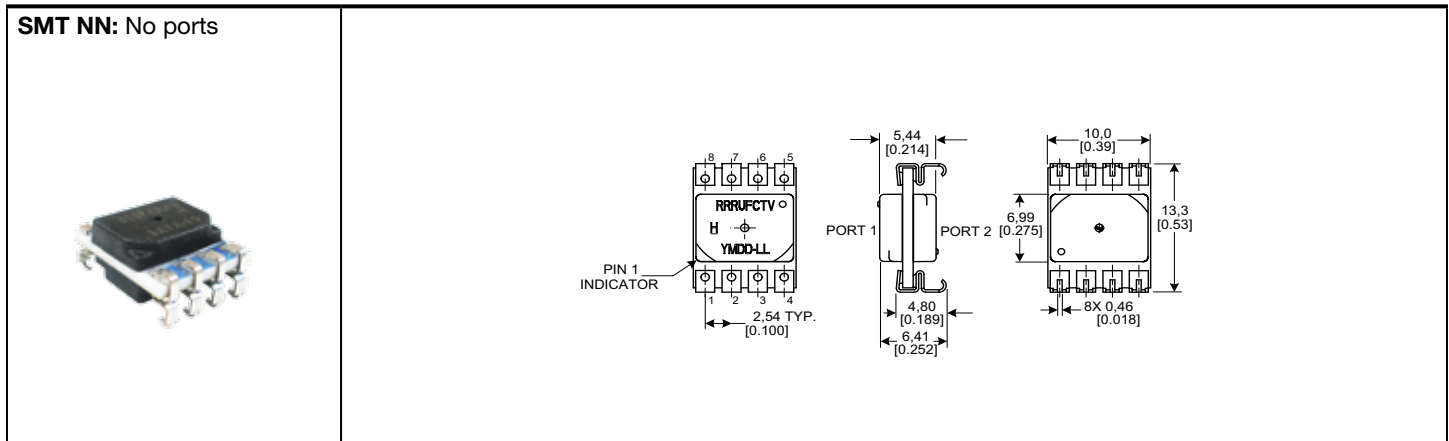


Figure 2. SMT Package Dimensional Drawings (For reference only: mm [in])



HSC Series – High Accuracy, Compensated/Amplified
SSC Series – Standard Accuracy, Compensated/Amplified

Issue F
50044171

Figure 2. SMT Package Dimensional Drawings (continued)


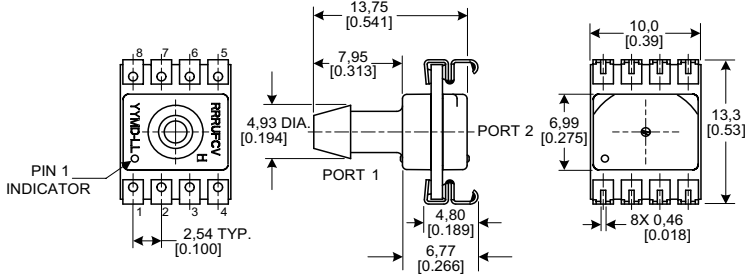

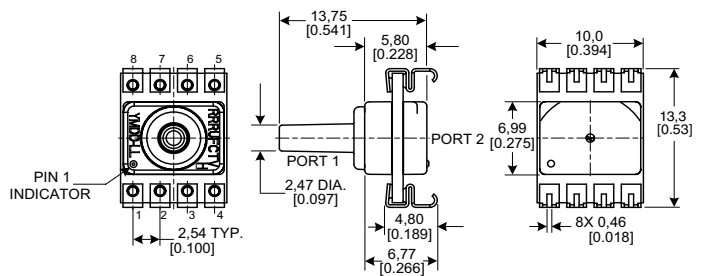

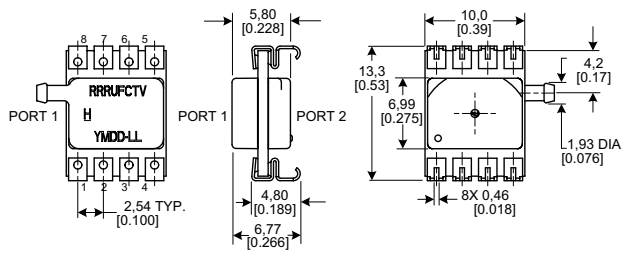
<p>SMT AN: Single axial barbed port</p> 	 <p>Dimensional drawing of SMT AN package showing top, side, and front views. Dimensions include: 13.75 [0.541] (total length), 7.95 [0.313] (barbed length), 4.93 DIA. [0.194] (PORT 1 diameter), 4.80 [0.189] (barbed diameter), 6.77 [0.266] (barbed length), 10.0 [0.39] (width), 6.99 [0.275] (height), 13.3 [0.53] (total height), 2.54 TYP. [0.100] (pitch), 8X 0.46 [0.018] (pin spacing), and PIN 1 INDICATOR.</p>
<p>SMT LN: Single axial barbless port</p> 	 <p>Dimensional drawing of SMT LN package showing top, side, and front views. Dimensions include: 13.75 [0.541] (total length), 5.80 [0.228] (barbed length), 2.47 DIA. [0.097] (PORT 1 diameter), 4.80 [0.189] (barbed diameter), 6.77 [0.266] (barbed length), 10.0 [0.394] (width), 6.99 [0.275] (height), 13.3 [0.53] (total height), 2.54 TYP. [0.100] (pitch), and 8X 0.46 [0.018] (pin spacing).</p>
<p>SMT RN: Single radial barbed port</p> 	 <p>Dimensional drawing of SMT RN package showing top, side, and front views. Dimensions include: 5.80 [0.228] (barbed length), 10.0 [0.39] (width), 13.3 [0.53] (total height), 6.99 [0.275] (height), 4.2 [0.17] (height), 1.93 DIA. [0.076] (PORT 2 diameter), 4.80 [0.189] (barbed diameter), 6.77 [0.266] (barbed length), 2.54 TYP. [0.100] (pitch), and 8X 0.46 [0.018] (pin spacing).</p>

Figure 2. SMT Package Dimensional Drawings (continued)

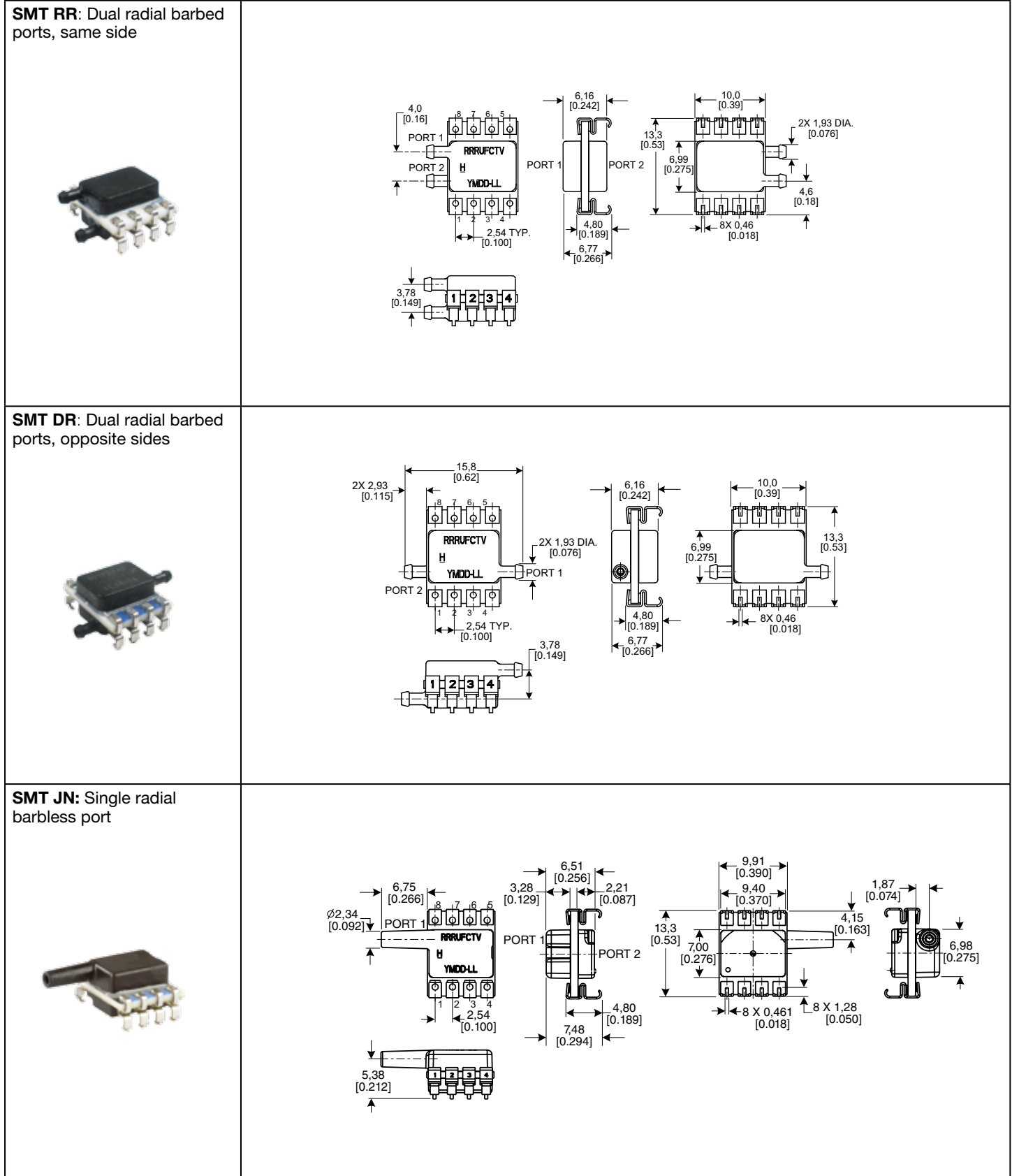


Figure 2. SMT Package Dimensional Drawings (continued)

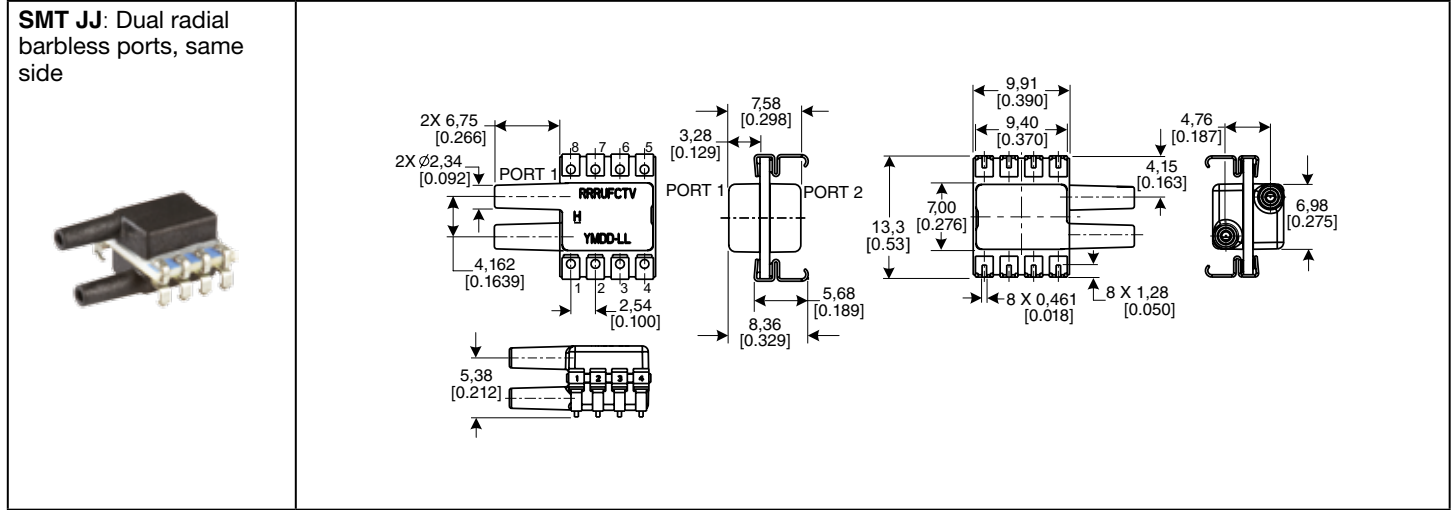
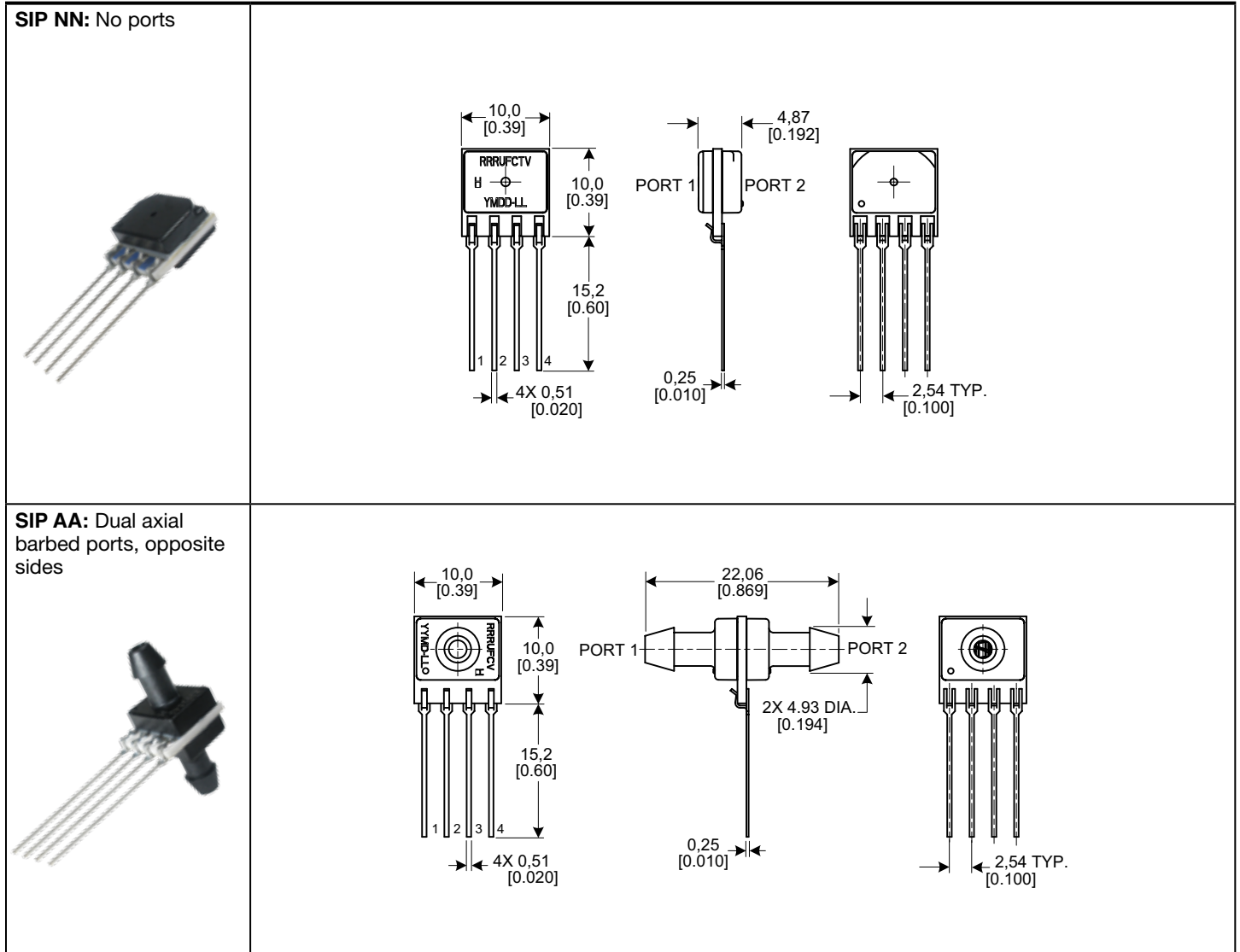


Figure 3. SIP Package Dimensional Drawings (For reference only: mm [in.])



HSC Series—High Accuracy, Compensated/Amplified
SSC Series—Standard Accuracy, Compensated/Amplified

Issue F
50044171

Figure 3. SIP Package Dimensional Drawings (continued)

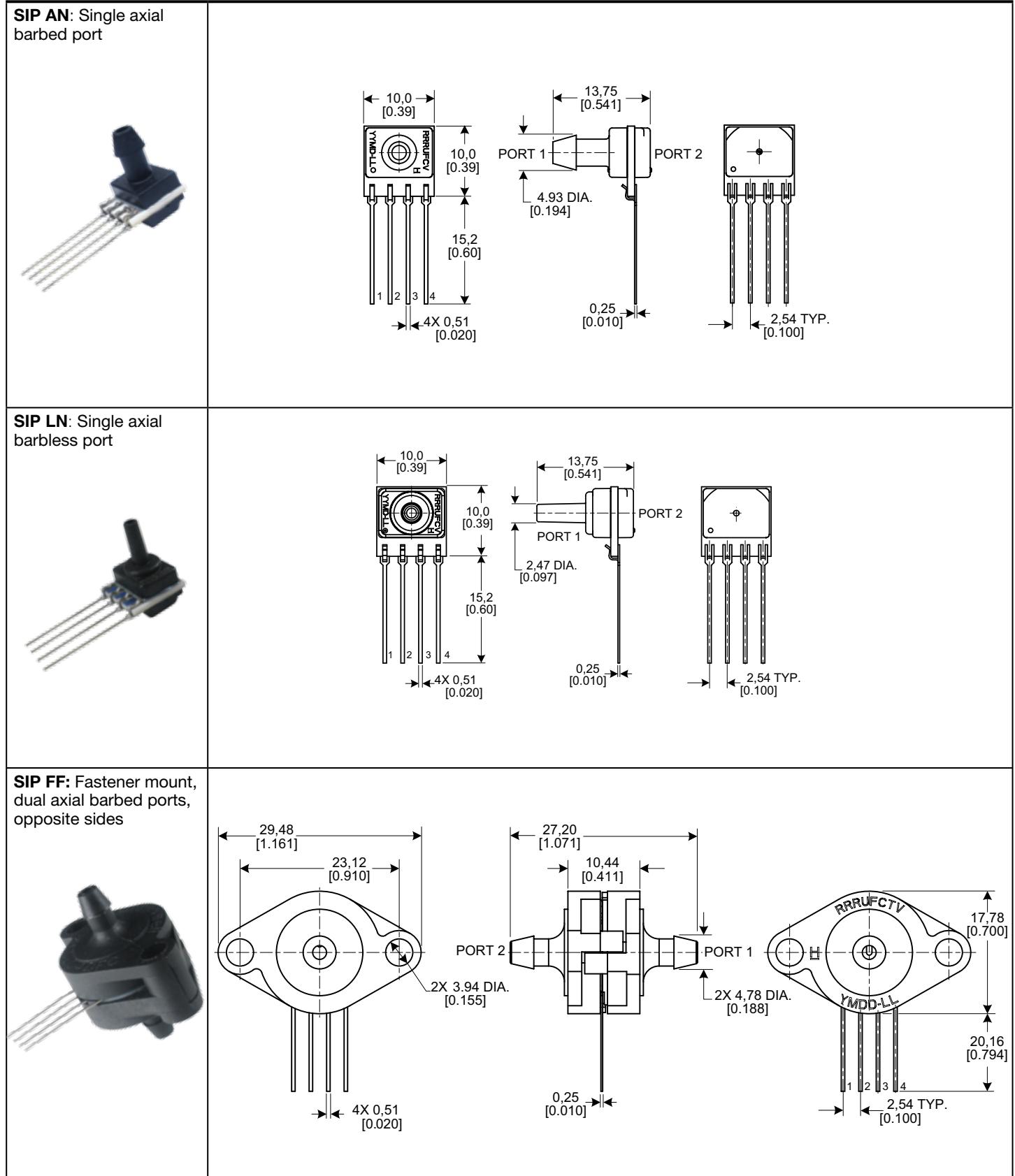
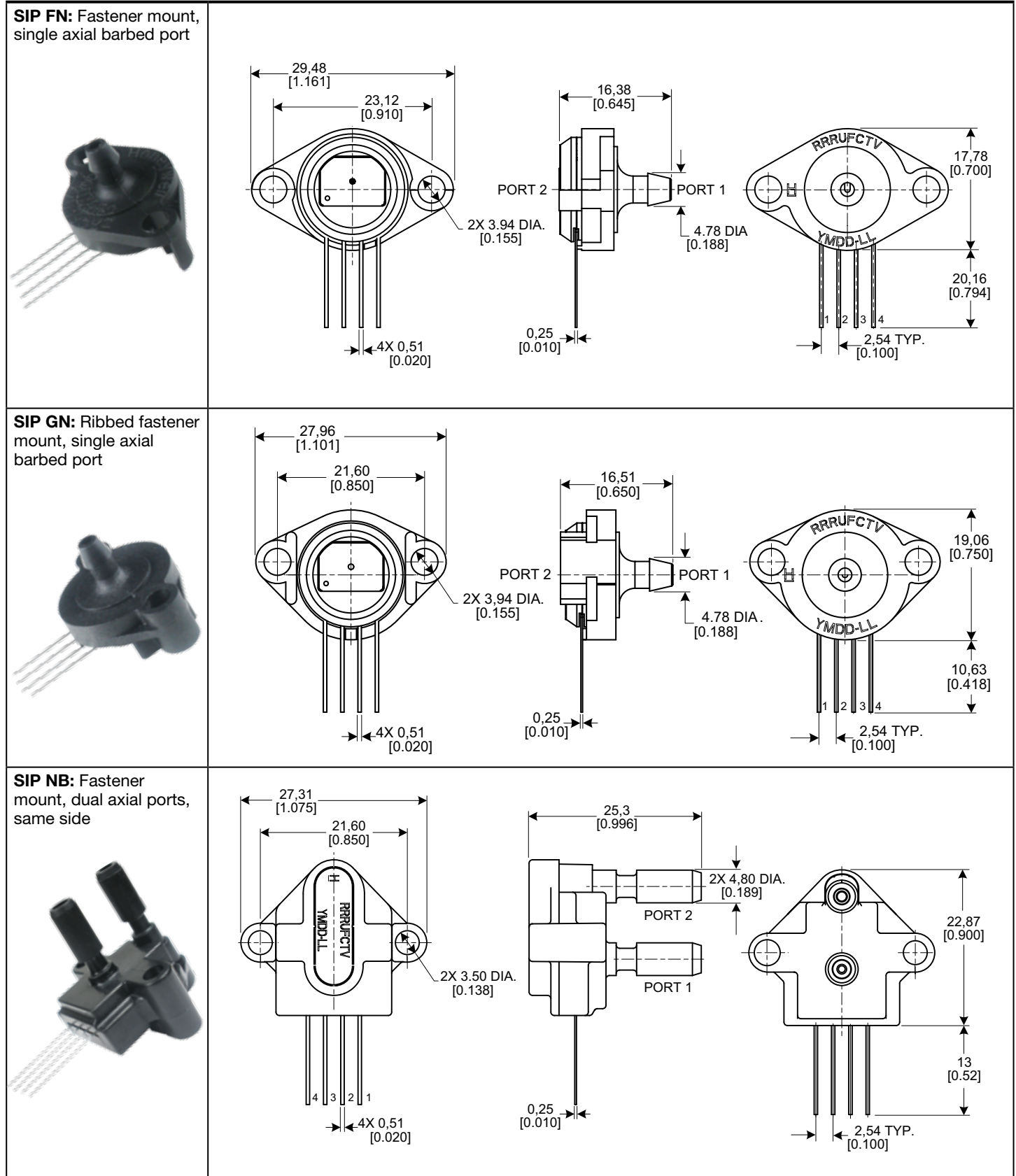


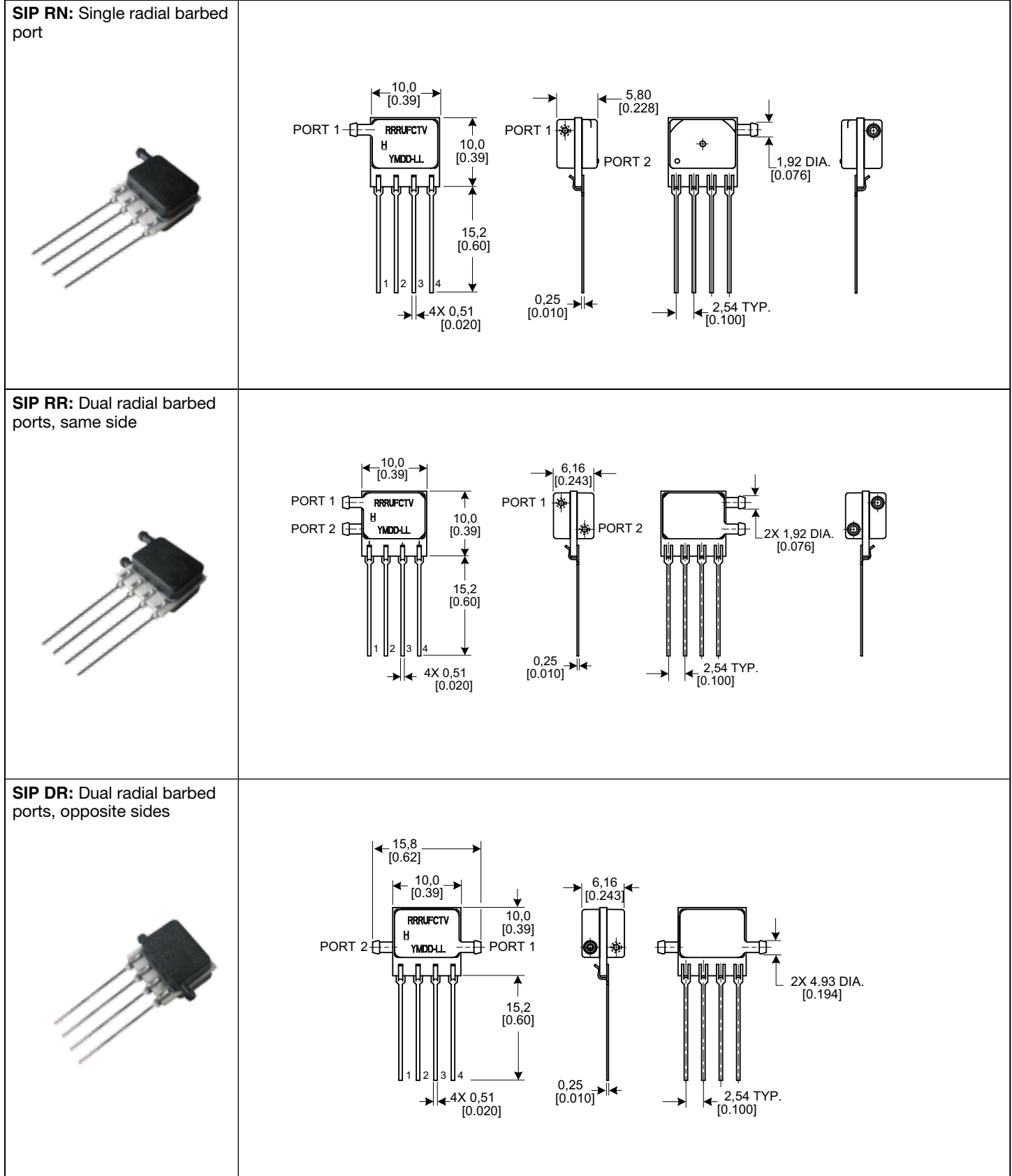
Figure 3. SIP Package Dimensional Drawings (continued)



HSC Series—High Accuracy, Compensated/Amplified
SSC Series—Standard Accuracy, Compensated/Amplified

Issue F
50044171

Figure 3. SIP Package Dimensional Drawings (continued)

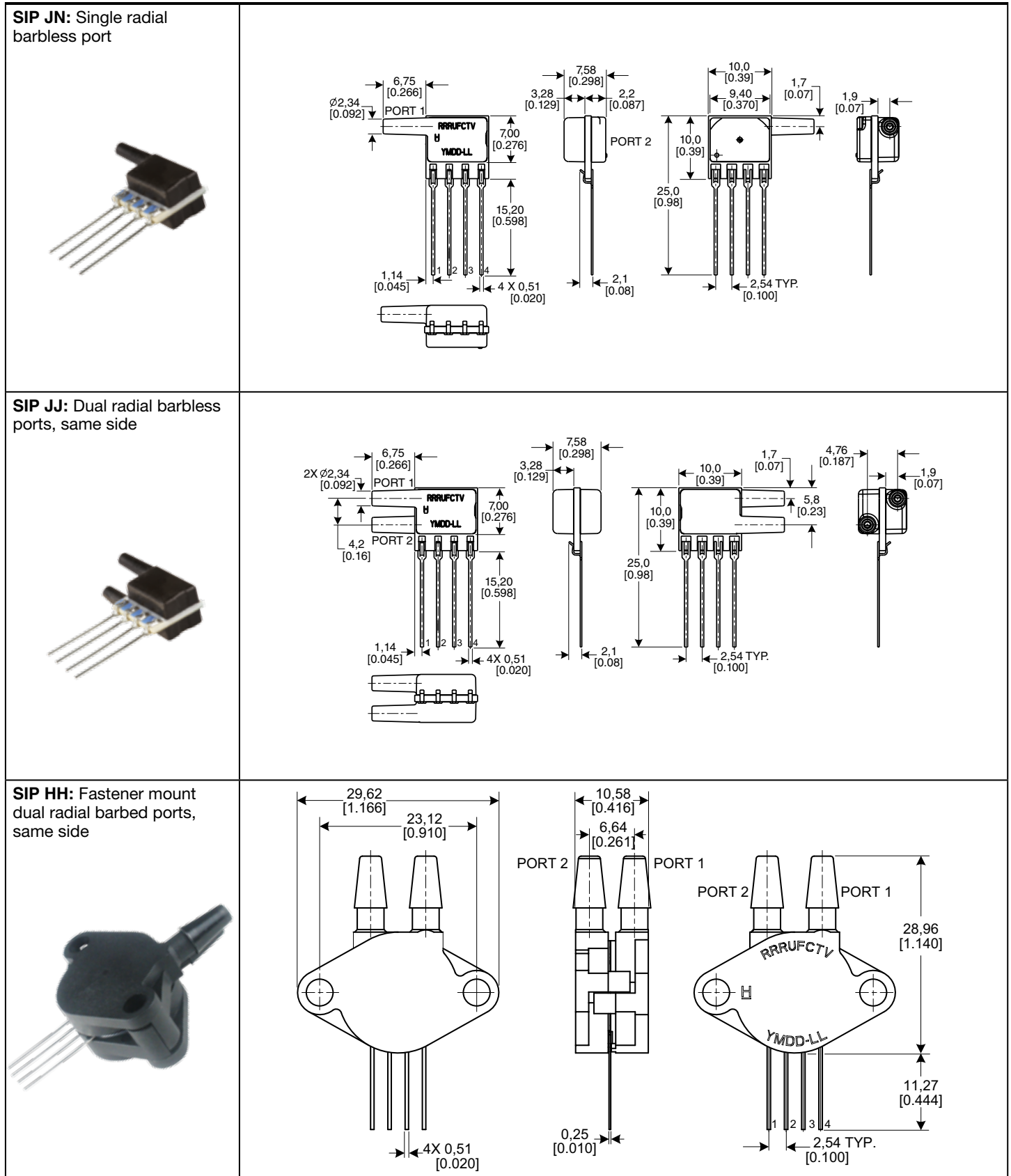


HSC Series – High Accuracy, Compensated/Amplified
SSC Series – Standard Accuracy, Compensated/Amplified

Issue F

50044171

Figure 3. SIP Package Dimensional Drawings (continued)



HSC Series—High Accuracy, Compensated/Amplified
SSC Series—Standard Accuracy, Compensated/Amplified

Issue F

50044171

Figure 3. SIP Package Dimensional Drawings (continued)

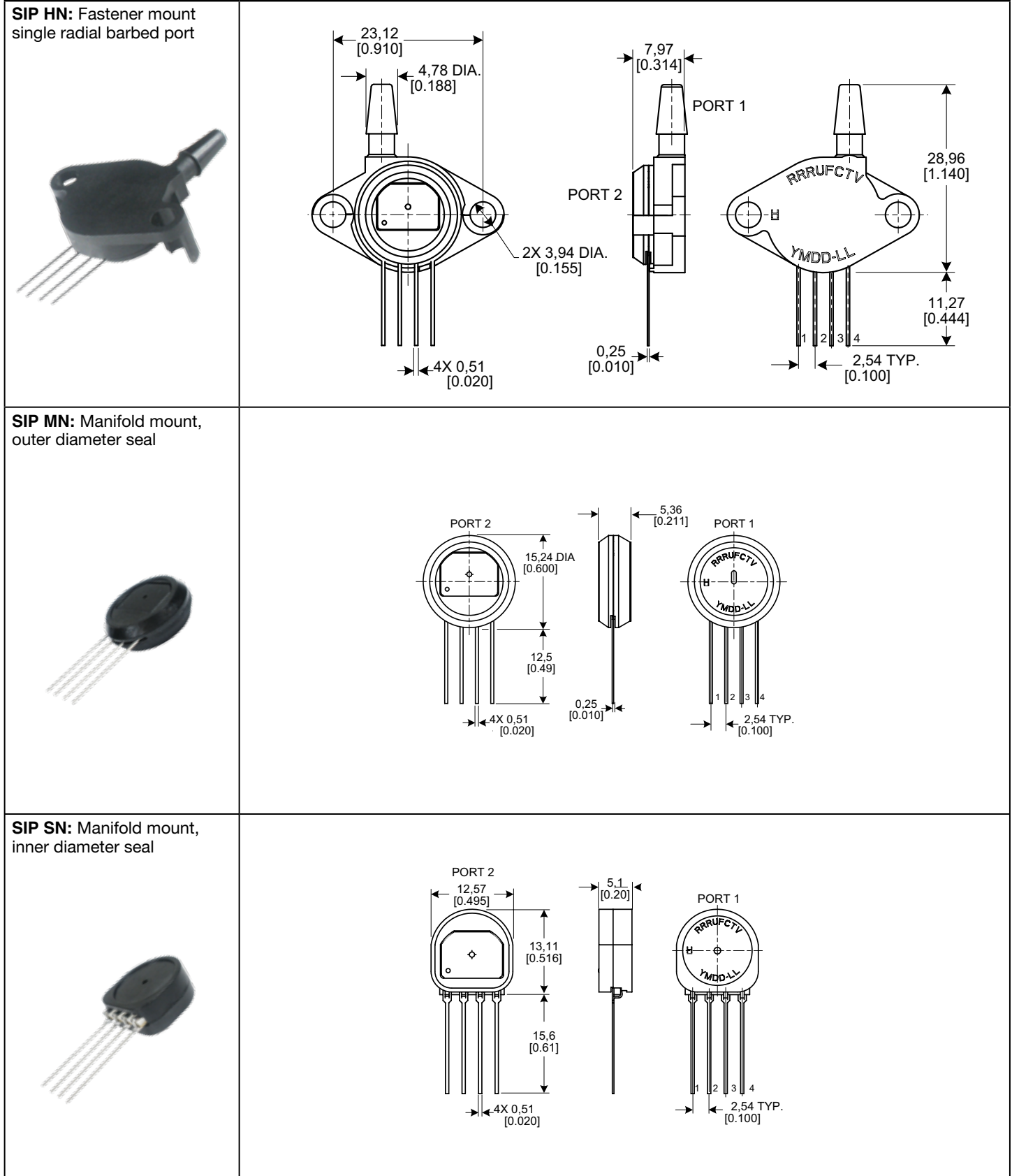


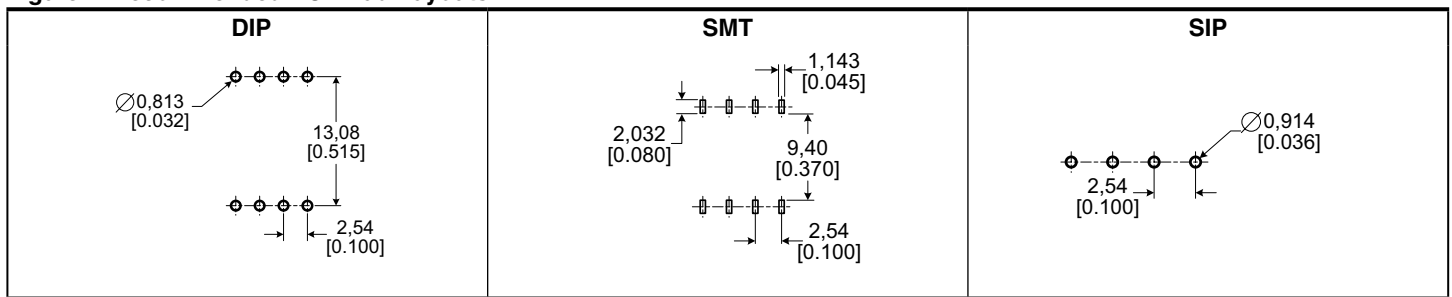
Table 6. Pinouts for DIP and SMT Packages

Output Type	Pin 1	Pin 2	Pin 3	Pin 4	Pin 5	Pin 6	Pin 7	Pin 8
I ² C	GND	Vsupply	SDA	SCL	NC	NC	NC	NC
SPI	GND	Vsupply	MISO	SCLK	SS	NC	NC	NC
Analog	NC	Vsupply	Vout	GND	NC	NC	NC	NC

Table 7. Pinouts for SIP Packages

Output Type	Pin 1	Pin 2	Pin 3	Pin 4
I ² C	GND	Vsupply	SDA	SCL
Analog	NC	Vsupply	Vout	GND

Figure 4. Recommended PCB Pad Layouts



HSC Series – High Accuracy, Compensated/Amplified

SSC Series – Standard Accuracy, Compensated/Amplified

Issue F

50044171

Figure 5. HSC Series Nomenclature and Order Guide

For example, **HSCDNNN150PGAA3** defines an HSC Series TruStability® Pressure Sensor, DIP package, NN pressure port, no special options, 150 psi gage pressure range, analog output type, 10% to 90% of Vsupply transfer function, 3.3 Vdc supply voltage.

Product Series			Package			Pressure Port			Supply Voltage			Transfer Function ¹			Output Type ²		
HSC High Accuracy, Compensated/Amplified			D DIP (Dual Inline Pin)			NN No ports			3 3.3 Vdc			A 10% to 90% of Vsupply (analog), 2 ¹⁴ counts (digital)			A Analog		
			M SMT (Surface Mount Technology)			AN Single axial barbed port			5 5.0 Vdc			B 5% to 95% of Vsupply (analog), 2 ¹⁴ counts (digital)			S SPI		
			S SIP (Single Inline Pin)			LN Single axial barbless port						C 5% to 85% of Vsupply (analog), 2 ¹⁴ counts (digital)			4 I ² C, Address 0x48		
						AA Dual axial barbed ports, opposite sides						F 4% to 94% of Vsupply (analog), 2 ¹⁴ counts (digital)			5 I ² C, Address 0x58		
						AN Single axial barbed port									6 I ² C, Address 0x68		
						LN Single axial barbless port									7 I ² C, Address 0x78		
						FF Fastener mount, dual axial barbed ports, opposite sides											
						FN Fastener mount, single axial barbed port											
						GN Ribbed fastener mount, single axial barbed port											
						NB Fastener mount, dual axial ports, same side											
						RN Single radial barbed port											
						RR Dual radial barbed ports, same side											
						DR Dual radial barbed ports, opposite sides											
						JN Single radial barbless port											
						JJ Dual radial barbless ports, same side											
						HH Fastener mount, dual radial barbed ports, same side											
						HN Fastener mount, single radial barbed port											
						MN Manifold mount, outer diameter seal											
						SN Manifold mount, inner diameter seal											

Pressure Range ^{3, 4}		
±1.6 mbar to ±10 bar		
<i>Absolute</i>		
001BA 0 bar to 1 bar	100KA 0 kPa to 100 kPa	015PA 0 psi to 15 psi
1.6BA 0 bar to 1.6 bar	160KA 0 kPa to 160 kPa	030PA 0 psi to 30 psi
2.5BA 0 bar to 2.5 bar	250KA 0 kPa to 250 kPa	060PA 0 psi to 60 psi
004BA 0 bar to 4 bar	400KA 0 kPa to 400 kPa	100PA 0 psi to 100 psi
006BA 0 bar to 6 bar	600KA 0 kPa to 600 kPa	150PA 0 psi to 150 psi
010BA 0 bar to 10 bar	001GA 0 kPa to 1 MPa	
<i>Differential</i>		
1.6MD ±1.6 mbar	160LD ±160 Pa	0.5ND ±0.5 inH ₂ O
2.5MD ±2.5 mbar	250LD ±250 Pa	001ND ±1 inH ₂ O
004MD ±4 mbar	400LD ±400 Pa	002ND ±2 inH ₂ O
006MD ±6 mbar	600LD ±600 Pa	004ND ±4 inH ₂ O
010MD ±10 mbar	001KD ±1 kPa	005ND ±5 inH ₂ O
016MD ±16 mbar	1.6KD ±1.6 kPa	010ND ±10 inH ₂ O
025MD ±25 mbar	2.5KD ±2.5 kPa	020ND ±20 inH ₂ O
040MD ±40 mbar	004KD ±4 kPa	030ND ±30 inH ₂ O
060MD ±60 mbar	006KD ±6 kPa	001PD ±1 psi
100MD ±100 mbar	010KD ±10 kPa	005PD ±5 psi
160MD ±160 mbar	016KD ±16 kPa	015PD ±15 psi
250MD ±250 mbar	025KD ±25 kPa	030PD ±30 psi
400MD ±400 mbar	040KD ±40 kPa	060PD ±60 psi
600MD ±600 mbar	060KD ±60 kPa	
001BD ±1 bar	100KD ±100 kPa	
1.6BD ±1.6 bar	160KD ±160 kPa	
2.5BD ±2.5 bar	250KD ±250 kPa	
004BD ±4 bar	400KD ±400 kPa	
<i>Gage</i>		
2.5MG 0 mbar to 2.5 mbar	250LG 0 Pa to 250 Pa	001NG 0 inH ₂ O to 1 inH ₂ O
004MG 0 mbar to 4 mbar	400LG 0 Pa to 400 Pa	002NG 0 inH ₂ O to 2 inH ₂ O
006MG 0 mbar to 6 mbar	600LG 0 Pa to 600 Pa	004NG 0 inH ₂ O to 4 inH ₂ O
010MG 0 mbar to 10 mbar	001KG 0 kPa to 1 kPa	005NG 0 inH ₂ O to 5 inH ₂ O
016MG 0 mbar to 16 mbar	1.6KG 0 kPa to 1.6 kPa	010NG 0 inH ₂ O to 10 inH ₂ O
025MG 0 mbar to 25 mbar	2.5KG 0 kPa to 2.5 kPa	020NG 0 inH ₂ O to 20 inH ₂ O
040MG 0 mbar to 40 mbar	004KG 0 kPa to 4 kPa	030NG 0 inH ₂ O to 30 inH ₂ O
060MG 0 mbar to 60 mbar	006KG 0 kPa to 6 kPa	001PG 0 psi to 1 psi
100MG 0 mbar to 100 mbar	010KG 0 kPa to 10 kPa	005PG 0 psi to 5 psi
160MG 0 mbar to 160 mbar	016KG 0 kPa to 16 kPa	015PG 0 psi to 15 psi
250MG 0 mbar to 250 mbar	025KG 0 kPa to 25 kPa	030PG 0 psi to 30 psi
400MG 0 bar to 400 mbar	040KG 0 kPa to 40 kPa	060PG 0 psi to 60 psi
600MG 0 bar to 600 mbar	060KG 0 kPa to 60 kPa	100PG 0 psi to 100 psi
001BG 0 bar to 1 bar	100KG 0 kPa to 100 kPa	150PG 0 psi to 150 psi
1.6BG 0 bar to 1.6 bar	160KG 0 kPa to 160 kPa	
2.5BG 0 bar to 2.5 bar	250KG 0 kPa to 250 kPa	
004BG 0 bar to 4 bar	400KG 0 kPa to 400 kPa	
006BG 0 bar to 6 bar	600KG 0 kPa to 600 kPa	
010BG 0 bar to 10 bar	001GG 0 kPa to 1 MPa	

Options ^{5, 6}		
N Dry gases only, no diagnostics		
D Dry gases only, diagnostics on		
T Liquid media on Port 1, no diagnostics		
V Liquid media on Port 1, diagnostics on		

¹The transfer function limits define the output of the sensor at a given pressure input. By specifying Pmin. and Pmax., the output at Pmin. and Pmax., the complete transfer function of the sensor is defined. See the graphical representations of the transfer function in the product datasheet, Figure 2. For other available transfer functions contact Honeywell Customer Service.
²SPI output function is not available in SIP package.
³Custom pressure ranges are available. Contact Honeywell Customer Service for more information.
⁴See the explanation of sensor pressure types in the product datasheet, Table 4.
⁵See the CAUTION in this document.
⁶Options T and V are only available on pressure ranges ±60 mbar to ±10 bar | ±6 kPa to ±1 MPa | ±1 psi to ±150 psi.

HSC Series – High Accuracy, Compensated/Amplified

SSC Series – Standard Accuracy, Compensated/Amplified

Issue F

50044171

Figure 6. SSC Series Nomenclature and Order Guide

For example, **SSCDNNN150PGAA3** defines an SSC Series TruStability® Pressure Sensor, DIP package, NN pressure port, no special options, 150 psi gage pressure range, analog output type, 10% to 90% of Vsupply transfer function, 3.3 Vdc supply voltage.

Product Series			Package			Pressure Port			Options ^{5, 6}			Supply Voltage		Transfer Function ¹				Output Type ²			
SSC Standard Accuracy, Compensated/Amplified			D DIP (Dual Inline Pin)			NN No ports			N Dry gases only, no diagnostics		3 3.3 Vdc		A 10% to 90% of Vsupply (analog), 2 ¹⁴ counts (digital)				A Analog				
			M SMT (Surface Mount Technology)			AN Single axial barbed port			D Dry gases only, diagnostics on		5 5.0 Vdc		B 5% to 95% of Vsupply (analog), 2 ¹⁴ counts (digital)				S SPI				
			S SIP (Single Inline Pin)			LN Single axial barbless port			T Liquid media on Port 1, no diagnostics				C 5% to 85% of Vsupply (analog), 2 ¹⁴ counts (digital)				2 I ² C, Address 0x28				
						AA Dual axial barbed ports, opposite sides			V Liquid media on Port 1, diagnostics on				F 4% to 94% of Vsupply (analog), 2 ¹⁴ counts (digital)				3 I ² C, Address 0x38				
						AN Single axial barbed port											4 I ² C, Address 0x48				
						LN Single axial barbless port											5 I ² C, Address 0x58				
						FF Fastener mount, dual axial barbed ports, opposite sides											6 I ² C, Address 0x68				
						FN Fastener mount, single axial barbed port											7 I ² C, Address 0x78				
						GN Ribbed fastener mount, single axial barbed port															
						NB Fastener mount, dual axial ports, same side															
						RN Single radial barbed port															
						RR Dual radial barbed ports, same side															
						DR Dual radial barbed ports, opposite sides															
						JN Single radial barbless port															
						JJ Dual radial barbless ports, same side															
						HH Fastener mount, dual radial barbed ports, same side															
						HN Fastener mount, single radial barbed port															
						MN Manifold mount, outer diameter seal															
						SN Manifold mount, inner diameter seal															

Pressure Range ^{3, 4}		
±1.6 mbar to ±10 bar	±160 Pa to ±1 MPa	±0.5 inH₂O to ±150 psi
<i>Absolute</i>	<i>Absolute</i>	<i>Absolute</i>
001BA 0 bar to 1 bar	100KA 0 kPa to 100 kPa	015PA 0 psi to 15 psi
1.6BA 0 bar to 1.6 bar	160KA 0 kPa to 160 kPa	030PA 0 psi to 30 psi
2.5BA 0 bar to 2.5 bar	250KA 0 kPa to 250 kPa	060PA 0 psi to 60 psi
004BA 0 bar to 4 bar	400KA 0 kPa to 400 kPa	100PA 0 psi to 100 psi
006BA 0 bar to 6 bar	600KA 0 kPa to 600 kPa	150PA 0 psi to 150 psi
010BA 0 bar to 10 bar	001GA 0 kPa to 1 MPa	
<i>Differential</i>	<i>Differential</i>	<i>Differential</i>
1.6MD ±1.6 mbar	160LD ±160 Pa	0.5ND ±0.5 inH ₂ O
2.5MD ±2.5 mbar	250LD ±250 Pa	001ND ±1 inH ₂ O
004MD ±4 mbar	400LD ±400 Pa	002ND ±2 inH ₂ O
006MD ±6 mbar	600LD ±600 Pa	004ND ±4 inH ₂ O
010MD ±10 mbar	001KD ±1 kPa	005ND ±5 inH ₂ O
016MD ±16 mbar	1.6KD ±1.6 kPa	010ND ±10 inH ₂ O
025MD ±25 mbar	2.5KD ±2.5 kPa	020ND ±20 inH ₂ O
040MD ±40 mbar	004KD ±4 kPa	030ND ±30 inH ₂ O
060MD ±60 mbar	006KD ±6 kPa	001PD ±1 psi
100MD ±100 mbar	010KD ±10 kPa	005PD ±5 psi
160MD ±160 mbar	016KD ±16 kPa	015PD ±15 psi
250MD ±250 mbar	025KD ±25 kPa	030PD ±30 psi
400MD ±400 mbar	040KD ±40 kPa	060PD ±60 psi
600MD ±600 mbar	060KD ±60 kPa	
001BD ±1 bar	100KD ±100 kPa	
1.6BD ±1.6 bar	160KD ±160 kPa	
2.5BD ±2.5 bar	250KD ±250 kPa	
004BD ±4 bar	400KD ±400 kPa	
<i>Gage</i>	<i>Gage</i>	<i>Gage</i>
2.5MG 0 mbar to 2.5 mbar	250LG 0 Pa to 250 Pa	001NG 0 inH ₂ O to 1 inH ₂ O
004MG 0 mbar to 4 mbar	400LG 0 Pa to 400 Pa	002NG 0 inH ₂ O to 2 inH ₂ O
006MG 0 mbar to 6 mbar	600LG 0 Pa to 600 Pa	004NG 0 inH ₂ O to 4 inH ₂ O
010MG 0 mbar to 10 mbar	001KG 0 kPa to 1 kPa	005NG 0 inH ₂ O to 5 inH ₂ O
016MG 0 mbar to 16 mbar	1.6KG 0 kPa to 1.6 kPa	010NG 0 inH ₂ O to 10 inH ₂ O
025MG 0 mbar to 25 mbar	2.5KG 0 kPa to 2.5 kPa	020NG 0 inH ₂ O to 20 inH ₂ O
040MG 0 mbar to 40 mbar	004KG 0 kPa to 4 kPa	030NG 0 inH ₂ O to 30 inH ₂ O
060MG 0 mbar to 60 mbar	006KG 0 kPa to 6 kPa	001PG 0 psi to 1 psi
100MG 0 mbar to 100 mbar	010KG 0 kPa to 10 kPa	005PG 0 psi to 5 psi
160MG 0 mbar to 160 mbar	016KG 0 kPa to 16 kPa	015PG 0 psi to 15 psi
250MG 0 mbar to 250 mbar	025KG 0 kPa to 25 kPa	030PG 0 psi to 30 psi
400MG 0 bar to 400 mbar	040KG 0 kPa to 40 kPa	060PG 0 psi to 60 psi
600MG 0 bar to 600 mbar	060KG 0 kPa to 60 kPa	100PG 0 psi to 100 psi
001BG 0 bar to 1 bar	100KG 0 kPa to 100 kPa	150PG 0 psi to 150 psi
1.6BG 0 bar to 1.6 bar	160KG 0 kPa to 160 kPa	
2.5BG 0 bar to 2.5 bar	250KG 0 kPa to 250 kPa	
004BG 0 bar to 4 bar	400KG 0 kPa to 400 kPa	
006BG 0 bar to 6 bar	600KG 0 kPa to 600 kPa	
010BG 0 bar to 10 bar	001GG 0 kPa to 1 MPa	

¹The transfer function limits define the output of the sensor at a given pressure input. By specifying Pmin. and Pmax., the output at Pmin. and Pmax., the complete transfer function of the sensor is defined. See the graphical representations of the transfer function in the product datasheet, Figure 2. For other available transfer functions contact Honeywell Customer Service.
²SPI output function is not available in SIP package.
³Custom pressure ranges are available. Contact Honeywell Customer Service for more information.
⁴See the explanation of sensor pressure types in the product datasheet, Table 4.
⁵See the CAUTION in this document.
⁶Options T and V are only available on pressure ranges ±60 mbar to ±10 bar | ±6 kPa to ±1 MPa | ±1 psi to ±150 psi.

HSC Series—High Accuracy, Compensated/Amplified

SSC Series—Standard Accuracy, Compensated/Amplified

Issue F

50044171

WARNING

PERSONAL INJURY

DO NOT USE these products as safety or emergency stop devices or in any other application where failure of the product could result in personal injury.

Failure to comply with these instructions could result in death or serious injury.

WARRANTY

Honeywell warrants goods of its manufacture as being free of defective materials and faulty workmanship. Honeywell's standard product warranty applies unless agreed to otherwise by Honeywell in writing; please refer to your order acknowledgement or consult your local sales office for specific warranty details. If warranted goods are returned to Honeywell during the period of coverage, Honeywell will repair or replace, at its option, without charge those items it finds defective. **The foregoing is buyer's sole remedy and is in lieu of all warranties, expressed or implied, including those of merchantability and fitness for a particular purpose. In no event shall Honeywell be liable for consequential, special, or indirect damages.**

While we provide application assistance personally, through our literature and the Honeywell web site, it is up to the customer to determine the suitability of the product in the application.

Specifications may change without notice. The information we supply is believed to be accurate and reliable as of this printing. However, we assume no responsibility for its use.

SALES AND SERVICE

Honeywell serves its customers through a worldwide network of sales offices, representatives and distributors. For application assistance, current specifications, pricing or name of the nearest Authorized Distributor, contact your local sales office or:

E-mail: info.sc@honeywell.com

Internet: sensing.honeywell.com

Phone and Fax:

Asia Pacific	+65 6355-2828
	+65 6445-3033 Fax
Europe	+44 (0) 1698 481481
	+44 (0) 1698 481676 Fax
Latin America	+1-305-805-8188
	+1-305-883-8257 Fax
USA/Canada	+1-800-537-6945
	+1-815-235-6847
	+1-815-235-6545 Fax

Sensing and Control
Honeywell
1985 Douglas Drive North
Golden Valley, MN 55422
honeywell.com

50044171-F-EN IL50
August 2014
© 2014 Honeywell International Inc. All rights reserved.

Honeywell

Looking for pricing, stock, or lifecycle information?

Click below to explore more details on WIN SOURCE:

 [View SSCMNNN001PG2A3 on WIN SOURCE](#)

 [Honeywell Information](#)

Optimize Your Supply Chain with WIN SOURCE Solutions

-  Global Sourcing Solution
-  Obsolete Management
-  Cost Control Management
-  Shortage Management
-  Alternative Solution
-  Excess Inventory Management