



**THE DATASHEET OF
BA7664AFV-E2**



High-performance Video Driver Series



Y/C MIX Circuit built-in Video Driver

BA7664AFV

No.09065EAT02

●Description

BA7664AFV is a 75Ω video driver, packaged in SSOP-B8, incorporating a 6dB amplifier, Y/C MIX circuit, sag compensation, and Mute function. This driver can drive two 75Ω loads. While the composite Y signal input is sync-tip-clamp, the chroma input has an internal termination at 20kΩ. The device also incorporates a power save circuit by activated when the output is under 0.2V.

●Features

- 1) A low consumption electric power movement
- 2) Built-in output mute circuit
- 3) Built-in power save circuit
- 4) Built-in output protection circuit
- 5) Low output coupling capacitor value can be used due to a built-in sag compensation circuit
- 6) The driver can have two loads (each channel)
- 7) Built-in Y/C MIX circuit

●Applications

DVD, DVC, DSC, STB, and visual instruments.

●Absolute maximum ratings (Ta=25°C)

Parameter	Symbol	Limits	Unit
Power Supply Voltage	Vcc	8	V
Power Dissipation	Pd	350 *1	mW
Operating Temperature Range	Topr	-25~+75	°C
Storage Temperature Range	Tstg	-55~+125	°C

*1 At the time of glass epoxy (FR-4) PCB mounting (70mm×70mm×1.6mm).
Reduce by 3.5 mW/°C over 25°C

●Operating range (Ta=25°C)

Parameter	Symbol	Min	Typ	Max	Unit
Supply voltage	Vcc	4.5	5.0	5.5	V

●Electrical characteristics

Electrical characteristics (unless otherwise specified, $V_{CC}=5V$, $T_a=25^\circ C$)

Parameter	Symbol	Min	Typ	Max	Unit	Conditions
Circuit Current	I_{CC}	6.1	12.2	18.3	mA	No-signal
Maximum Output Level	V_{om}	2.6	3.0	-	V_{P-P}	$f=1kHz, THD=1\% V_{O2}$
Voltage Gain	G_V	-1.0	-0.2	0.6	dB	$f=4.43MHz, 1V_{pp}/V_{O1}$
Frequency Characteristics	G_F	-1.5	-0.5	0.5	dB	$f=7MHz/1MHz, 1V_{P-P}/V_{O1}$
MUTE Attenuation	M_T	-	-60	-	dB	$f=4.43MHz, 1V_{P-P}/V_{O1}$
Mute Threshold "H"	V_{THH}	2.2	-	V_{CC}	V	-
Mute Threshold "L"	V_{THL}	0	-	0.7	V	-
Input Impedance	Z_{IN}	16	20	24	$k\Omega$	Chroma input terminal
Supply Current in Mute	I_{MUTE}	-	1.3	2.6	mA	MUTEA "H"

Guaranteed design parameters (unless otherwise specified, $V_{CC}=5V$, $T_a=25^\circ C$)

Parameter	Symbol	Min	Typ	Max	Unit	Conditions
Differential Gain	DG	-	1.0	2.0	%	$V_{IN}=1V_{P-P}$ Standard staircase signal
Differential Phase	DP	-	0.5	2.0	DEG	$V_{IN}=1V_{P-P}$ Standard staircase signal

●Block diagram / Application circuit

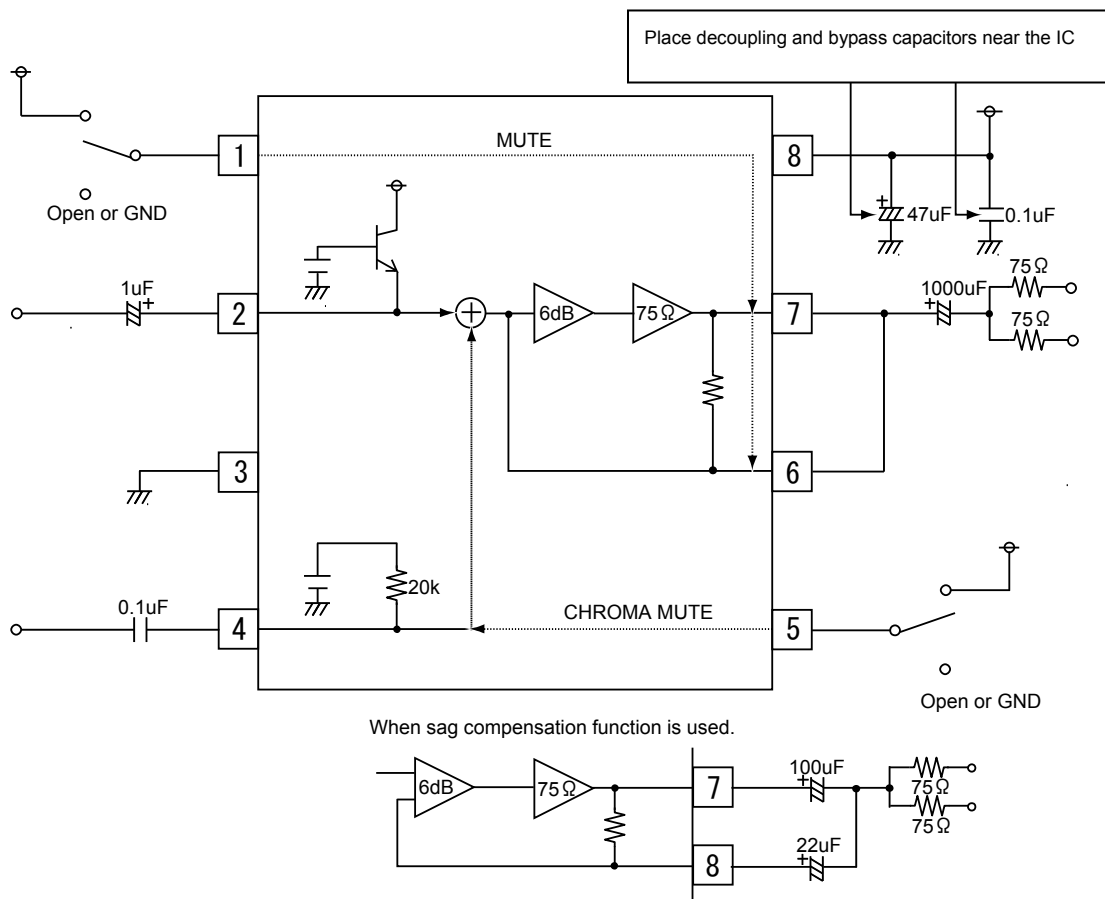

※ Make sure to take into account the tolerance characteristics of the external components, as well as the IC power dissipation limits.

Fig.1

●Equivalent circuit

Pin.No	Pin name	IN	OUT	Voltage	Equivalent circuit	Function
1 5	MUTEA MUTEB	○	—	—		Mute control terminal Pin1 MUTEA - "H" = mute on Pin5 MUTEB - "H" = only chroma mute on
2	Y _{IN}	○	—	2.0V		Signal input terminal Sync-tip-clamp input for the composite Y signal.
3	GND	—	—	0V		Ground terminal
4	C _{IN}	○	—	2.0V		Signal input terminal This pin is a chroma signal input. Input terminal is 20kΩ.
6 7	MIXOUT2 MIXOUT1	—	○	0.9V 0.95V		Signal output terminal Pin7 is Y/C MIX signal output terminal. Power save mode is active when output is set under 0.2V. Pin6 is a sag compensator input.
8	V _{CC}	—	—	5.0V		Power supply terminal

●Cautions on use

- Numbers and data in entries are representative design values and are not guaranteed values of the items.
- Although ROHM is confident that the example application circuit reflects the best possible recommendations, be sure to verify circuit characteristics for your particular application. Modification of constants for other externally connected circuits may cause variations in both static and transient characteristics for external components as well as this ROHM IC. Allow for sufficient margins when determining circuit constants.
- Absolute maximum ratings
Use of the IC in excess of absolute maximum ratings, such as the applied voltage or operating temperature range (Topr), may result in IC damage. Assumptions should not be made regarding the state of the IC (short mode or open mode) when such damage is suffered. A physical safety measure, such as a fuse, should be implemented when using the IC at times where the absolute maximum ratings may be exceeded.
- GND potential
Ensure a minimum GND pin potential in all operating conditions. Make sure that no pins are at a voltage below the GND at any time, regardless of whether it is a transient signal or not.
- Thermal design
Perform thermal design, in which there are adequate margins, by taking into account the permissible dissipation (Pd) in actual states of use.
- Short circuit between terminals and erroneous mounting
Pay attention to the assembly direction of the ICs. Wrong mounting direction or shorts between terminals, GND, or other components on the circuits, can damage the IC.
- Operation in strong electromagnetic field
Using the ICs in a strong electromagnetic field can cause operation malfunction.

Notes

No copying or reproduction of this document, in part or in whole, is permitted without the consent of ROHM Co.,Ltd.

The content specified herein is subject to change for improvement without notice.

The content specified herein is for the purpose of introducing ROHM's products (hereinafter "Products"). If you wish to use any such Product, please be sure to refer to the specifications, which can be obtained from ROHM upon request.

Examples of application circuits, circuit constants and any other information contained herein illustrate the standard usage and operations of the Products. The peripheral conditions must be taken into account when designing circuits for mass production.

Great care was taken in ensuring the accuracy of the information specified in this document. However, should you incur any damage arising from any inaccuracy or misprint of such information, ROHM shall bear no responsibility for such damage.

The technical information specified herein is intended only to show the typical functions of and examples of application circuits for the Products. ROHM does not grant you, explicitly or implicitly, any license to use or exercise intellectual property or other rights held by ROHM and other parties. ROHM shall bear no responsibility whatsoever for any dispute arising from the use of such technical information.

The Products specified in this document are intended to be used with general-use electronic equipment or devices (such as audio visual equipment, office-automation equipment, communication devices, electronic appliances and amusement devices).

The Products specified in this document are not designed to be radiation tolerant.

While ROHM always makes efforts to enhance the quality and reliability of its Products, a Product may fail or malfunction for a variety of reasons.

Please be sure to implement in your equipment using the Products safety measures to guard against the possibility of physical injury, fire or any other damage caused in the event of the failure of any Product, such as derating, redundancy, fire control and fail-safe designs. ROHM shall bear no responsibility whatsoever for your use of any Product outside of the prescribed scope or not in accordance with the instruction manual.

The Products are not designed or manufactured to be used with any equipment, device or system which requires an extremely high level of reliability the failure or malfunction of which may result in a direct threat to human life or create a risk of human injury (such as a medical instrument, transportation equipment, aerospace machinery, nuclear-reactor controller, fuel-controller or other safety device). ROHM shall bear no responsibility in any way for use of any of the Products for the above special purposes. If a Product is intended to be used for any such special purpose, please contact a ROHM sales representative before purchasing.

If you intend to export or ship overseas any Product or technology specified herein that may be controlled under the Foreign Exchange and the Foreign Trade Law, you will be required to obtain a license or permit under the Law.



Thank you for your accessing to ROHM product informations.
More detail product informations and catalogs are available, please contact us.

ROHM Customer Support System

<http://www.rohm.com/contact/>

Looking for pricing, stock, or lifecycle information?

Click below to explore more details on WIN SOURCE:

- ⊖ [View BA7664AFV-E2 on WIN SOURCE](#)
- ⊖ [Rohm Semiconductor](#) Information

Optimize Your Supply Chain with WIN SOURCE Solutions

- ✓ Global Sourcing Solution
- ✓ Obsolete Management
- ✓ Cost Control Management
- ✓ Shortage Management
- ✓ Alternative Solution
- ✓ Excess Inventory Management