

High-performance Video Signal Switchers

Single-circuit Video Switchers

BA7654F,BA7653AF,BA7653AFV,BA7652AF

No.11066EAT04

●Description

The BA7654F, BA7653A F/FV or BA7652AF is a video signal (display signal) switch containing one 2-input or 3-input circuit. Each of the input pin formats is "sync-tip clamp input" that matches the synchronous tips of video signals (display signals) to the same potential. The inputs have an high input impedance configuration, in which they can utilize a small clamp capacitor (0.01 μF (FZ) ceramic capacitor is recommended).

●Features

- 1) Low value clamp capacitance can be used (Min. 3000 pF Recommended 0.01 μF (FZ) ceramic capacitor)
- 2) Low voltage operation is possible (Operating range 4.0~7.0V)
- 3) Superimposed can be applied since switching speed of SW is fast and there is little switching noise (Typ. 70ns)
- 4) Low power consumption (Typ. 25mW when Vcc=5V)
- 5) Large dynamic range (Typ. 3.1V_{P-P} when Vcc=5V)
- 6) Good frequency characteristics (Typ. 10 MHz 0 dB)
- 7) Low interchannel crosstalk (Typ. -70 dB)
- 8) Voltage can be applied to the CTL pin without a VCC voltage.
- 9) Built-in mute function (BA7652AF)

●Applications

VCR, TV, and other applications that use display signals.

●Product lineup

Part No.	Input type	Mute	Supply voltage(V)
BA7654F	2 in 1 Circuit	—	4.0 ~ 7.0
BA7653AF, BA7653AFV	3 in 1 Circuit	—	
BA7652AF	3 in 1 Circuit	○	

●Absolute maximum ratings(Ta=25°C)

Parameter	Symbol	Ratings				Unit
		BA7654F	BA7653AF	BA7653AFV	BA7652AF	
Supply voltage	Vcc	9				V
Power dissipation	Pd	500* ¹	500* ¹	350* ²	500* ¹	mW
Operating temperature	T _{opr}	-25~+75	-30~+80	-30~+80	-30~+80	°C
Storage temperature	T _{stg}	-55~+125				°C

*1 Reduce by 5.0mW/°C over 25°C, when mounted on a 50mm × 50mm PCB board.(BA7654F, BA7653AF, BA7652AF)

*2 Reduce by 3.5mW/°C over 25°C, when mounted on a 50mm × 50mm PCB board.(BA7653AFV)

●Operating range($T_a=25^{\circ}\text{C}$)

Parameter	Symbol	Ratings	Unit
Supply voltage	V _{CC}	4.0 ~ 7.0	V

Note: This IC is not designed to be radiation-resistant.

●Electrical characteristics(Unless otherwise noted, $T_a=25^{\circ}\text{C}$, V_{CC}=5.0V)

Parameter	Symbol	Limits			Unit	Conditions
		Min.	Typ.	Max.		
Circuit current	I _{CC}	2.7	5.0	8.2	mA	
Maximum output level	V _{om}	2.6	3.1	—	V _{P-P}	f=1kHz, THD=1.0%
Voltage gain	G _v	-0.5	0	+0.5	dB	f=1MHz, V _{IN} =1.0V _{P-P}
Inter channel crosstalk	C _{ta}	—	-70	—	dB	f=4.43MHz, V _{IN} =1.0V _{P-P}
Frequency characteristics	C _f	-3.0	0	+1.0	dB	f=10MHz/1MHz, V _{IN} =1.0V _{P-P}
CTL switching voltage	V _{TH L}	—	—	1.0	V	V _{TH} =(V _{CC} -0.75)×0.44
	V _{TH H}	2.5	—	—		

●Guaranteed design parameters (Unless otherwise noted, $T_a=25^{\circ}\text{C}$, V_{CC}=5.0V)

Parameter	Symbol	Limits			Unit	Conditions
		Min.	Typ.	Max.		
Differential phase	D _G	—	0	0.5	%	V _{IN} =1.0V _{P-P} , standard staircase signal
Differential gain	D _P	—	0.5	1.0	deg	V _{IN} =1.0V _{P-P} , standard staircase signal

●Block diagram

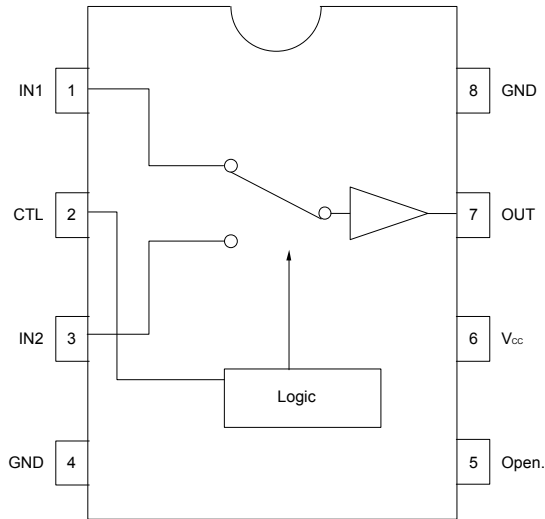

Fig.1 BA7654F

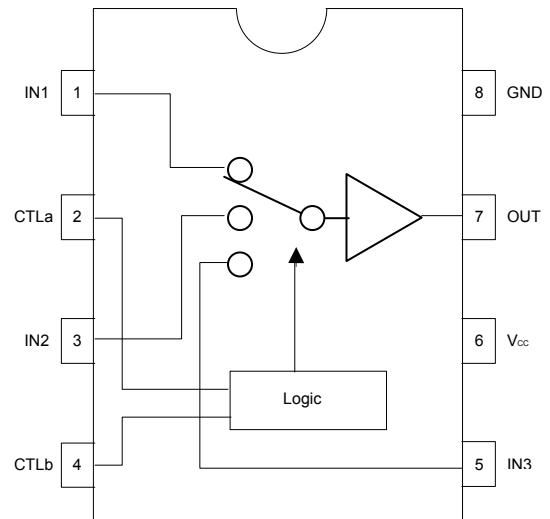

Fig.2 BA7653AF, BA7653AFV

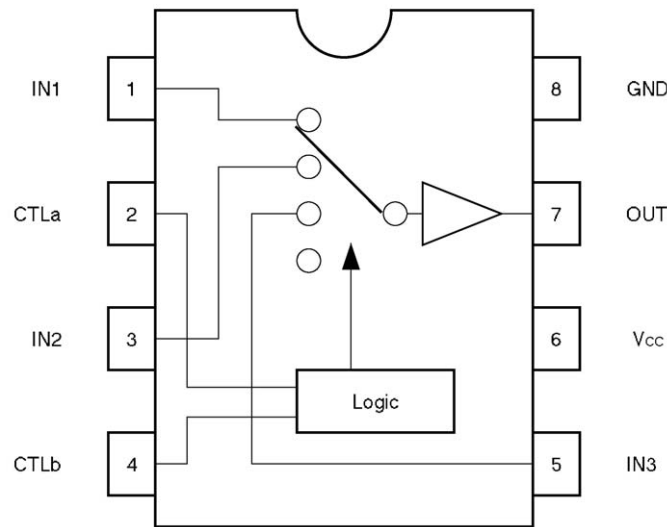

Fig.3 BA7652AF

●Control Pin Settings

BA7654F	
CTL	OUT
L	IN1
H	IN2

BA7653AF, BA7653AFV		
CTLa	CTLb	OUT
L	L	IN1
H	L	IN2
L	H	IN3
H	H	IN3

BA7652AF		
CTLa	CTLb	OUT
L	L	IN1
H	L	IN2
L	H	IN3
H	H	MUTE

●Pin descriptions 1/2 (BA7654F)

BA7654F				
Pin No.	Pin name	DC voltage (Vcc=5V)	Input/output impedance	Equivalent circuit
1 (3)	IN1 (IN2)	1.65V	10MΩ or more	
2	CTL	—	—	
4 (8)	GND	0V	—	
5	N.C.	open	open	—
6	Vcc	0.5V	—	
7	OUT	0.95V	26Ω	

●Pin descriptions 2/2 (BA7653AF, BA7653AFV, BA7652AF)

BA7653AF, BA7653AFV, BA7652AF				
Pin No.	Pin name	DC voltage (Vcc=5V)	Input/output impedance	Equivalent circuit
1 (3) (5)	IN1 (IN2) (IN3)	1.65V	10MΩ or more	
2	CTLa	—	—	
4	CTLb	—	—	
6	Vcc	5.0V	—	
7	OUT	0.95V	26Ω	
8	GND	0V	—	

●Application circuit 1/2 (BA7654F)

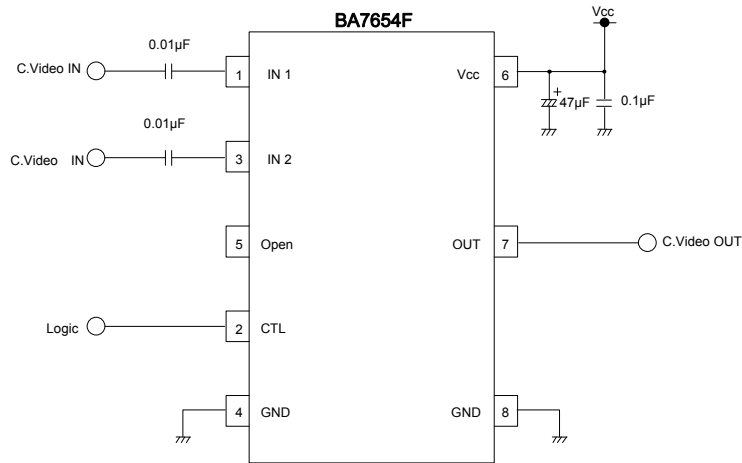

Fig.4

(When superimposition is used)

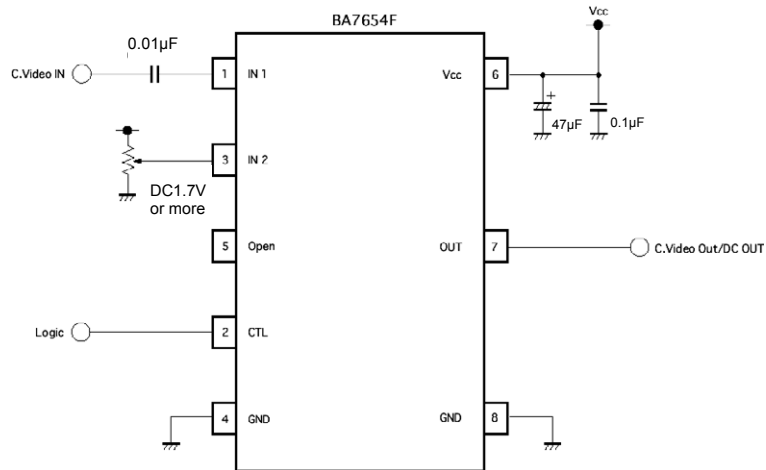

Fig.5

●Application circuit 2/2 (BA7653AF, BA7653AFV, BA7652AF)

BA7653AF, BA7653AFV, BA7652AF

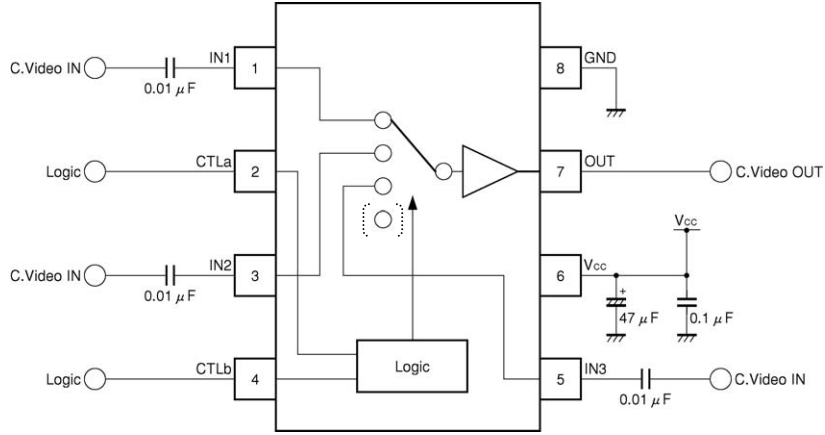

Fig.6

(When superimposition is used)

BA7653AF, BA7653AFV, BA7652AF

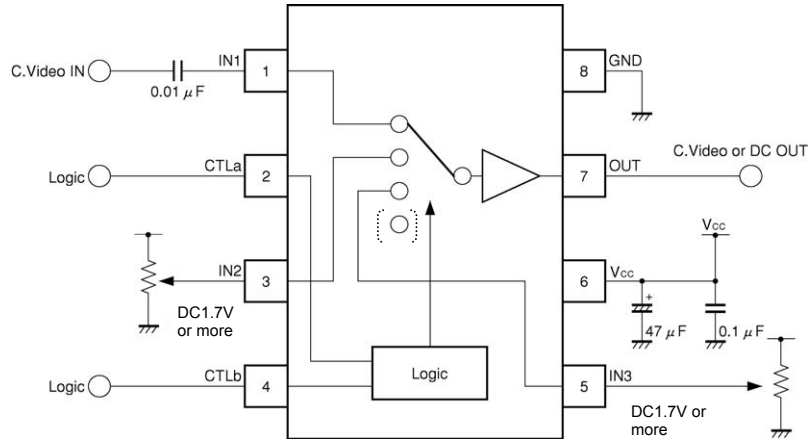

Fig.7

●Notes for use

1. Numbers and data in entries are representative design values and are not guaranteed values of the items.
2. Although ROHM is confident that the example application circuit reflects the best possible recommendations, be sure to verify circuit characteristics for your particular application. Modification of constants for other externally connected circuits may cause variations in both static and transient characteristics for external components as well as this Rohm IC. Allow for sufficient margins when determining circuit constants.
3. Absolute maximum ratings
Use of the IC in excess of absolute maximum ratings, such as the applied voltage or operating temperature range (Topr), may result in IC damage. Assumptions should not be made regarding the state of the IC (short mode or open mode) when such damage is suffered. A physical safety measure, such as a fuse, should be implemented when using the IC at times where the absolute maximum ratings may be exceeded.
4. GND potential
Ensure a minimum GND pin potential in all operating conditions. Make sure that no pins are at a voltage below the GND at any time, regardless of whether it is a transient signal or not.
5. Thermal design
Perform thermal design, in which there are adequate margins, by taking into account the permissible dissipation (Pd) in actual states of use.
6. Short circuit between terminals and erroneous mounting
Pay attention to the assembly direction of the ICs. Wrong mounting direction or shorts between terminals, GND, or other components on the circuits, can damage the IC.
7. Operation in strong electromagnetic field
Using the ICs in a strong electromagnetic field can cause operation malfunction.
8. For clamp operation stability
Set the output impedance of the stage before input pin no more than 1 kΩ.
9. An input clamp capacitor will cause delay in operation at power on. Therefore, it is recommended to use a clamp capacitor no larger than 0.1 μF (0.01 μF (FZ) ceramic capacitor is recommended).
10. The BA7653AF, BA7653AFV and BA7652AF are 3-input, 1-output switch. If it is used as a 2-input, 1-output switch, by leaving one input Open and unused, the Open input pin will oscillate. However, this does not affect other pins and is not particularly a problem for operation. If necessary, connect the input pin to GND via a capacitor or connect the input pin directly to VCC to stop oscillation.
11. CTL pin is in indeterminate status when left Open. Set it at "H" or "L" level.
12. For superimposed, a 1.7V DC voltage should be applied directly to an input pin.

●Ordering part number

B	A
---	---

Part No.

7	6	5	3	A
---	---	---	---	---

Part No.
7654
7653A
7652A

F	V
---	---

Package
F : SOP8
FV:SSOP-B8

E	2
---	---

Packaging and forming specification
E2: Embossed tape and reel

SOP8

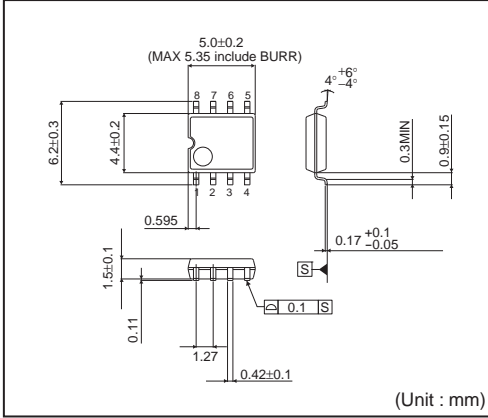

<Tape and Reel information>

Tape	Embossed carrier tape
Quantity	2500pcs
Direction of feed	E2 (The direction is the 1pin of product is at the upper left when you hold reel on the left hand and you pull out the tape on the right hand)

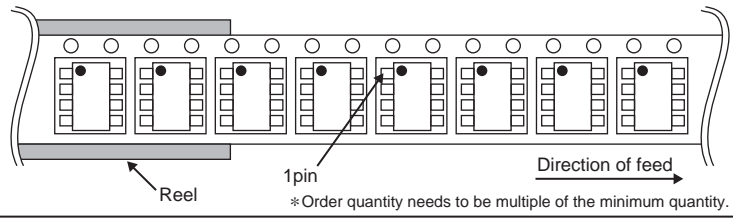

SSOP-B8

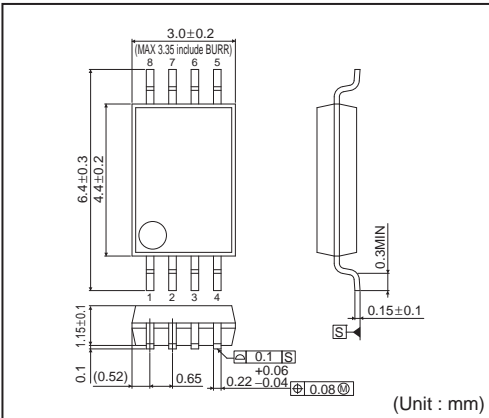

<Tape and Reel information>

Tape	Embossed carrier tape
Quantity	2500pcs
Direction of feed	E2 (The direction is the 1pin of product is at the upper left when you hold reel on the left hand and you pull out the tape on the right hand)

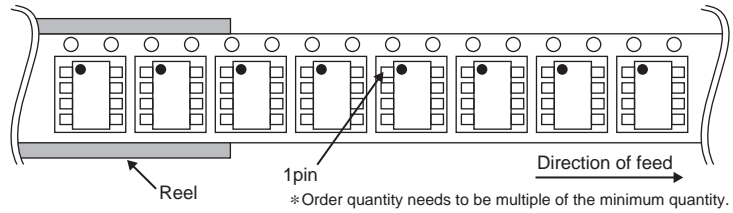

Notes

No copying or reproduction of this document, in part or in whole, is permitted without the consent of ROHM Co.,Ltd.

The content specified herein is subject to change for improvement without notice.

The content specified herein is for the purpose of introducing ROHM's products (hereinafter "Products"). If you wish to use any such Product, please be sure to refer to the specifications, which can be obtained from ROHM upon request.

Examples of application circuits, circuit constants and any other information contained herein illustrate the standard usage and operations of the Products. The peripheral conditions must be taken into account when designing circuits for mass production.

Great care was taken in ensuring the accuracy of the information specified in this document. However, should you incur any damage arising from any inaccuracy or misprint of such information, ROHM shall bear no responsibility for such damage.

The technical information specified herein is intended only to show the typical functions of and examples of application circuits for the Products. ROHM does not grant you, explicitly or implicitly, any license to use or exercise intellectual property or other rights held by ROHM and other parties. ROHM shall bear no responsibility whatsoever for any dispute arising from the use of such technical information.

The Products specified in this document are intended to be used with general-use electronic equipment or devices (such as audio visual equipment, office-automation equipment, communication devices, electronic appliances and amusement devices).

The Products specified in this document are not designed to be radiation tolerant.

While ROHM always makes efforts to enhance the quality and reliability of its Products, a Product may fail or malfunction for a variety of reasons.

Please be sure to implement in your equipment using the Products safety measures to guard against the possibility of physical injury, fire or any other damage caused in the event of the failure of any Product, such as derating, redundancy, fire control and fail-safe designs. ROHM shall bear no responsibility whatsoever for your use of any Product outside of the prescribed scope or not in accordance with the instruction manual.

The Products are not designed or manufactured to be used with any equipment, device or system which requires an extremely high level of reliability the failure or malfunction of which may result in a direct threat to human life or create a risk of human injury (such as a medical instrument, transportation equipment, aerospace machinery, nuclear-reactor controller, fuel-controller or other safety device). ROHM shall bear no responsibility in any way for use of any of the Products for the above special purposes. If a Product is intended to be used for any such special purpose, please contact a ROHM sales representative before purchasing.

If you intend to export or ship overseas any Product or technology specified herein that may be controlled under the Foreign Exchange and the Foreign Trade Law, you will be required to obtain a license or permit under the Law.





Thank you for your accessing to ROHM product informations.
More detail product informations and catalogs are available, please contact us.

ROHM Customer Support System

<http://www.rohm.com/contact/>

Looking for pricing, stock, or lifecycle information?

Click below to explore more details on WIN SOURCE:

-  [View BA7653AF-E2 on WIN SOURCE](#)
-  [Rohm Semiconductor](#) Information

Optimize Your Supply Chain with WIN SOURCE Solutions

-  Global Sourcing Solution
-  Obsolete Management
-  Cost Control Management
-  Shortage Management
-  Alternative Solution
-  Excess Inventory Management