



**THE DATASHEET OF
LGA80D-00DADJJ**



ARTESYN LGA80D SERIES

Dual O/P Non-isolated 80 A Digital
DC/DC Converter



Advanced Energy's Artesyn LGA80D is a non-isolated DC-DC converter that is designed for cost and space sensitive applications.

This non-isolated unit offers two independent and configurable 40 amp, 100 watt outputs, which can also be combined to a single configurable 80 amp, 200 watt output. With a footprint of 1 x 0.5 inches or 25.4 x 12.5 mm.

SPECIAL FEATURES

- Two-phase design
- Dual or single output configuration possible
- High efficiency up to 95.5%
- Small size 1" x 0.5" x 0.48" (LxWxH)
- Supports PMBus
- No minimum load requirement
- Wide operating temperature range
- Exceptional power density
- Automatic loop compensation
- Excellent transient response
- Analog or digital control
- IPC9592B compliant
- Tape and reel packaging
- Reflow compatible
- Possible to stack up to 8 phases for 320 A
- Two year warranty (Consult factory for extended terms)

SAFETY

- Designed to meet IEC62368

DATA SHEET

Total Current:

80 A (single)
40 A (dual)

Input Voltage:

7.5 - 14 Vdc

Variable Output:

0.6 - 5.2 V



ELECTRICAL SPECIFICATIONS

Input		
Input voltage range	7.5 -14 Vdc	
Max input current @ 7.5 V	33 A	
Input capacitor (internal)	120 μ F	
Environmental and General Information		
Operating ambient temperature	-40 °C to +85 °C	
Storage temperature	-40 °C to +125 °C	
Switching frequency (RSYNC = 23.7 Kohm)	457 kHz typical (can be configured)	
CMTBF Telcordia SR-332, Issue 3, Method 1 Case 1	50 MHours	
Protection		
Overcurrent protection	Refer to application note for detail	
Overvoltage protection	110% Vo nominal	
Overtemperature protection (controller temperature)	120 °C nominal	
Output*		
Independent output 1 and 2	0.6 V to 1 V	40 A
	1.8 V	35 A
	2.5 V	32.5 A
	3.3 V	30 A
	5 V	20 A
Combined output 1 and 2	0.6 V to 1 V	80 A
	1.8 V	70 A
	2.5 V	65 A
	3.3 V	60 A
	5 V	40 A
Efficiency at 11 Vin and 25 °C	1 V @ 80 A	89.9% typical
	1.8 V @ 70 A	93% typical
	2.5 V @ 65 A	94.5% typical
	3.3 V @ 60 A	95% typical
	5 V @ 40 A	95.5% typical
Max output power (Watts)	200 W	

*Output @ Vin = 12 V, Ta = 25 °C, unless otherwise noted

Parameter	Conditions	Min	Nom	Max
Line regulation 0.6 ~ 1.0 V 1.0 ~ 5.0 V	Measured at remote sense	—	2 mV	—
		—	0.2%	—
Load regulation 0.6 ~ 1.0 V 1.0 ~ 5.0 V	Measured at remote sense	—	5 mV	—
		—	0.5%	—
Output capacitor per output (external minimum)	2 x 220 μ F / 6.3 V polymer tan caps (6TPF220M5L or equivalent) 3 x 100 μ F / 6.3 V ceramic caps	—	740 μ F	—
Ripple and noise (with minimum caps) 5 Hz to 20 MHz 0.6 to 1.8 V 2.5 V to 3.3 V 5.0 V	One module one output	—	15 mV	—
		—	25 mV	—
		—	40 mV	—
		—	—	—
Ripple and noise (with minimum caps) 5 Hz to 20 MHz 0.6 to 1.8 V 2.5 V to 3.3 V 5.0 V	One module two outputs	—	18 mV	—
		—	35 mV	—
		—	50 mV	—
		—	—	—

ORDERING INFORMATION

Model Number	Input Voltage	Output Voltage Set Point	Output Current	Efficiency
LGA80D-00DADJJ	7.5 - 14 Vdc	See table	80 A max	See table

BLOCK DIAGRAM - ONE MODULE ONE OUTPUT

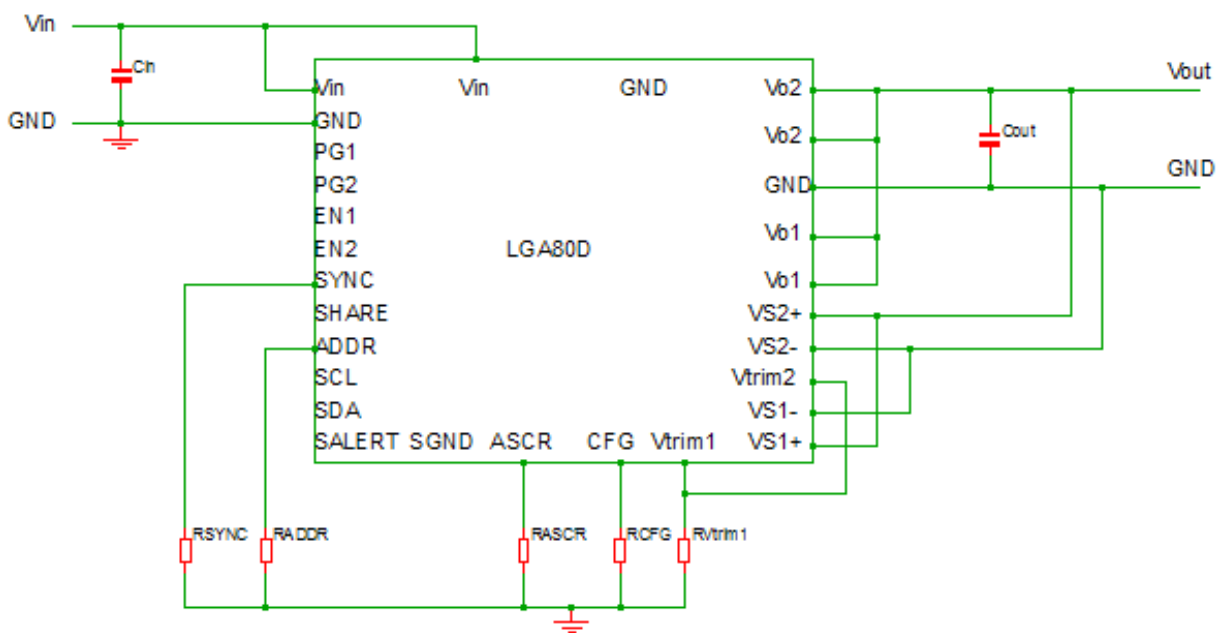

BLOCK DIAGRAM - ONE MODULE TWO OUTPUTS

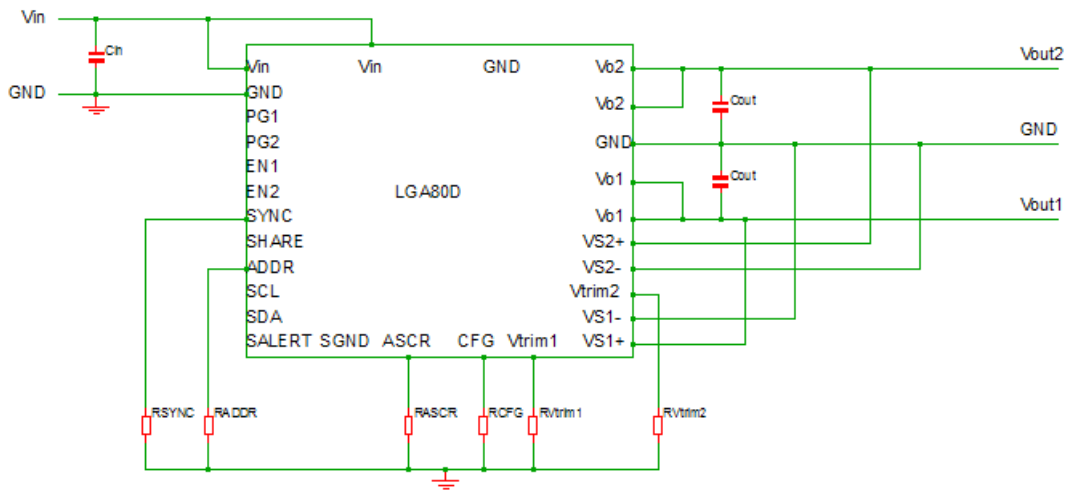

BLOCK DIAGRAM - TWO MODULES ONE OUTPUT

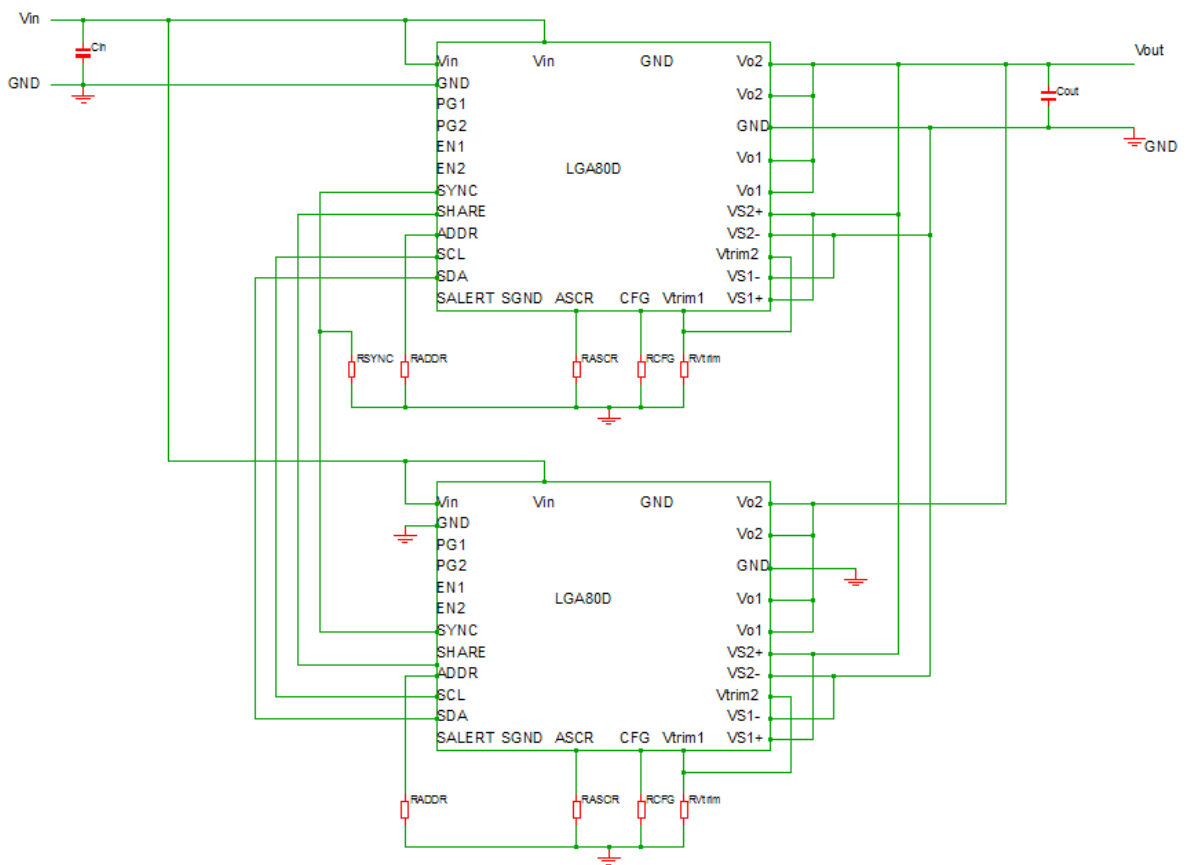

VOUT & ADDRESS SETTINGS

Vout Setting	
RVtrim (k Ω)	Vout (V)
LOW	1
OPEN	1.2
HIGH	0.9
10	0.6
11	0.65
12.1	0.7
13.3	0.75
14.7	0.8
16.2	0.85
17.8	0.9
19.6	0.95
21.5	1
23.7	1.05
26.1	1.1
28.7	1.15
31.6	1.2
34.8	1.25
38.3	1.3
42.2	1.4
46.4	1.5
51.1	1.6
56.2	1.7
61.9	1.8
68.1	1.9
75	2
82.5	2.1
90.9	2.2
100	2.3
110	2.5
121	2.8
133	3
147	3.3
162	4
178	5

Address Setting	
RADDR (k Ω)	SMBus ADDRESS
LOW	40h
OPEN	42h
10	41h
11	43h
12.1	44h
13.3	45h
14.7	46h
16.2	47h
17.8	48h
19.6	49h
21.5	4Ah
23.7	4Bh
26.1	4Ch
28.7	4Dh
31.6	4Eh
34.8	4Fh
42.2	51h
46.4	52h
51.1	53h
56.2	54h
61.9	55h
68.1	56h
75	57h
82.5	58h
90.9	59h
100	5Ah
110	5Bh
121	5Ch
133	5Dh
147	5Eh
162	5Fh
178	60h

MECHANICAL DRAWINGS

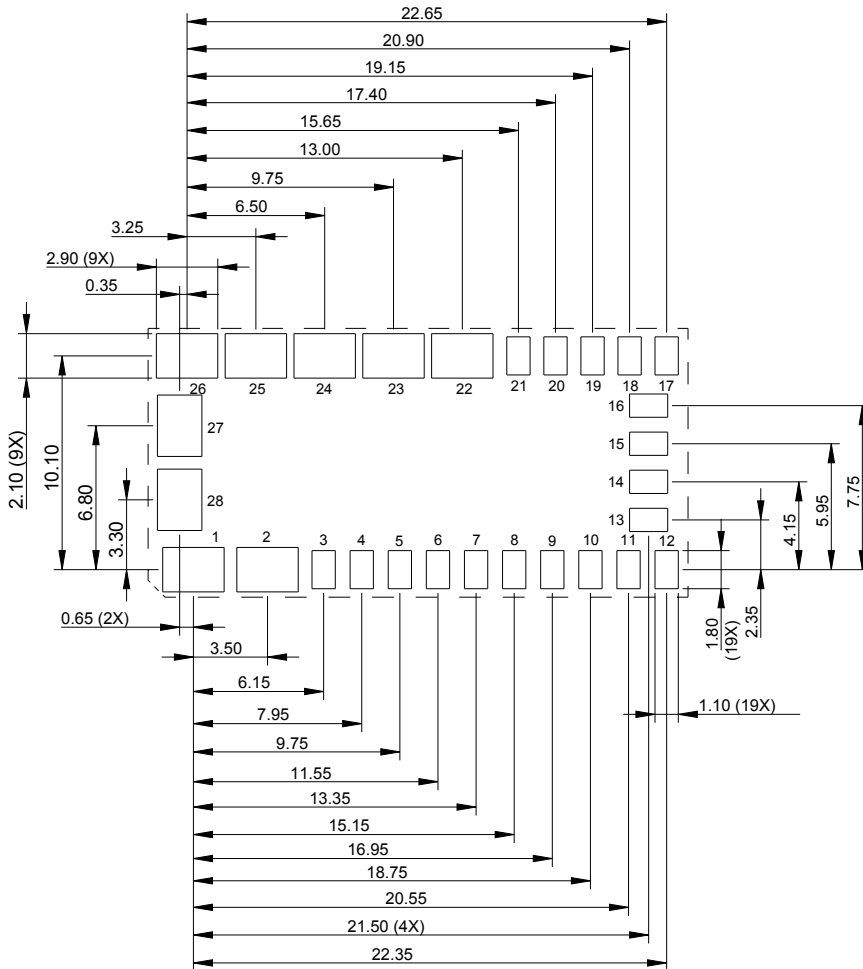

Pin Assignments Single Output	
Pin #	Function
1	Vin
2	GND
3	PG1
4	PG2
5	EN1
6	EN2
7	SYNC
8	SHARE
9	ADDR
10	SCL
11	SDA
12	SALERT
13	SGND
14	ASCRCFG
15	CFG
16	Vtrim1
17	VS1+
18	VS1-
19	Vtrim2
20	VS2-
21	VS2+
22	Vo1
23	Vo1
24	GND
25	Vo2
26	Vo2
27	GND
28	Vin

RECOMMENDED PAD LAYOUT (FOOTPRINT)

Notes:

Dimensions are in millimeters and (inches)

Tolerance: X.X mm ±0.5 mm (X.XX in. ±0.02 in.)

X.XX mm ±0.25 mm (X.XXX in. ±0.010 in.)

MECHANICAL DRAWINGS (CONTINUED)

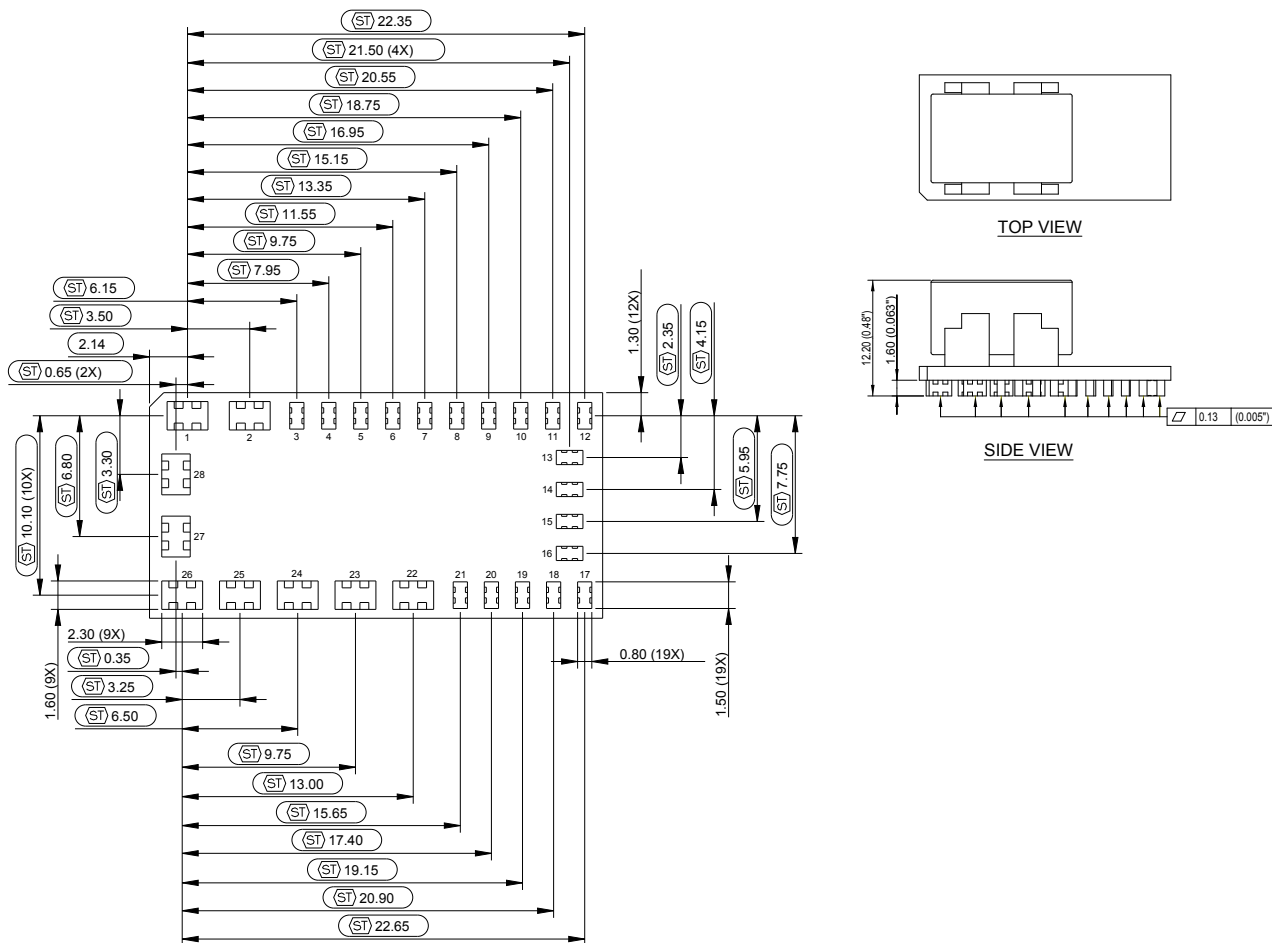

FOOTPRINT DRAWING OF METAL PINS
(BOTTOM VIEW)

Notes:

Dimensions are in millimeters and (inches)

Tolerance: X.X mm ±0.5 mm (X.XX in. ±0.02 in.)

X.XX mm ±0.25 mm (X.XXX in. ±0.010 in.)



For international contact information,
visit advancedenergy.com.

powersales@aei.com (Sales Support)
productsupport.ep@aei.com (Technical Support)
+1 888 412 7832

ABOUT ADVANCED ENERGY

Advanced Energy (AE) has devoted more than three decades to perfecting power for its global customers. AE designs and manufactures highly engineered, precision power conversion, measurement and control solutions for mission-critical applications and processes.

Our products enable customer innovation in complex applications for a wide range of industries including semiconductor equipment, industrial, manufacturing, telecommunications, data center computing, and medical. With deep applications know-how and responsive service and support across the globe, we build collaborative partnerships to meet rapid technological developments, propel growth for our customers, and innovate the future of power.

PRECISION | POWER | PERFORMANCE

Specifications are subject to change without notice. Not responsible for errors or omissions. ©2020 Advanced Energy Industries, Inc. All rights reserved. Advanced Energy®, AE® and Artesyn™ are U.S. trademarks of Advanced Energy Industries, Inc.

Looking for pricing, stock, or lifecycle information?

Click below to explore more details on WIN SOURCE:

- ⊖ [View LGA80D-00DADJJ on WIN SOURCE](#)
- ⊖ [Artesyn Embedded Technologies Information](#)

Optimize Your Supply Chain with WIN SOURCE Solutions

- ✓ Global Sourcing Solution
- ✓ Obsolete Management
- ✓ Cost Control Management
- ✓ Shortage Management
- ✓ Alternative Solution
- ✓ Excess Inventory Management