



**THE DATASHEET OF  
NX5P3090UKZ**



# NX5P3090

## USB PD and type C current-limited power switch

Rev. 1 — 1 August 2016

Product data sheet

### 1. General description

---

The NX5P3090 is a precision adjustable current-limited power switch for USB PD application. The device includes under voltage lockout, over-temperature protection, and reverse current protection circuits to automatically isolate the switch terminals when a fault condition occurs. The 29 V tolerance on VBUS pin ensures the device is able to work on a USB PD port; a current limit input (ILIM) pin defines the over-current limit threshold; an open-drain fault output ( $\overline{\text{FAULT}}$ ) indicates when a fault condition has occurred.

The over-current limit threshold can be programmed from 400 mA to 3.3 A, using an external resistor between the ILIM pin and GND pin. In the over current condition, the device will clamp the output current to the value set by ILIM and keep the switch on while assert the FAULT flag. To minimize current surges during turn on, the device has built in soft start which controls the power switch rise time.

Surge protection has been integrated in the device to enhance system robustness. The enable input includes integrated logic level translation making the device compatible with lower voltage processors and controllers.

NX5P3090 is offered in a 12 bump 1.35 x 1.65 mm, 0.4 mm pitch WLCSP package.

### 2. Features and benefits

---

- VINT supply voltage range from 2.5 V to 5.5 V
- 29 V tolerance on VBUS and EN pin
- Adjustable current limit from 400 mA to 3.3 A
- Clamped current output in over-current condition
- Very low ON resistance: 34 m $\Omega$  (typical)
- Active HIGH EN pin with internal pull down resistor
- All time Reverse Current Protection
- Over Temperature Protection
- Surge protection: IEC61000-4-5 exceeds  $\pm 80$  V on VBUS
- Safety approvals
  - ◆ UL 62368-1, 2nd Edition, File no. 20160526-E470128
  - ◆ IEC 62368-1 (ed.2), File no. DK-54536-UL
- ESD protection
  - ◆ IEC61000-4-2 contact discharge exceeds 8 kV on VBUS
  - ◆ HBM ANSI/ESDA/JEDEC JS-001 Class 2 exceeds 2 kV
  - ◆ CDM AEC standard Q100-01 (JESD22-C101E) exceeds 500 V
- Specified from  $-40$  °C to  $+85$  °C ambient temperature



### 3. Applications

- Notebook and Ultrabook
- USB PD and Type C port/hubs
- Tablet and Smart phone

### 4. Ordering information

Table 1. Ordering information

Type number	Topside marking	Package		
		Name	Description	Version
NX5P3090UK	X5PT2	WLCSP12	wafer level chip-scale package; 12 bumps; 1.65 x 1.35 x 0.525 mm; 0.4 mm pitch (backside coating included)	SOT1390-5

#### 4.1 Ordering options

Table 2. Ordering options

Type number	Orderable part number	Package	Packing method	Minimum order quantity	Temperature
NX5P3090UK	NX5P3090UKZ	WLCSP12	REEL 7" Q1/T1 *SPECIAL MARK CHIPS DP	3000	T <sub>amb</sub> = -40 °C to +85 °C

### 5. Marking

Table 3. Marking

Line	Marking	Description
A	X5PT2	basic type name
B	mmmmm	wafer lot code (mmmmm)
C	Z5YWW	manufacturing code Z = foundry location 5 = assembly location Y = assembly year code WW = assembly week code

## 6. Functional diagram

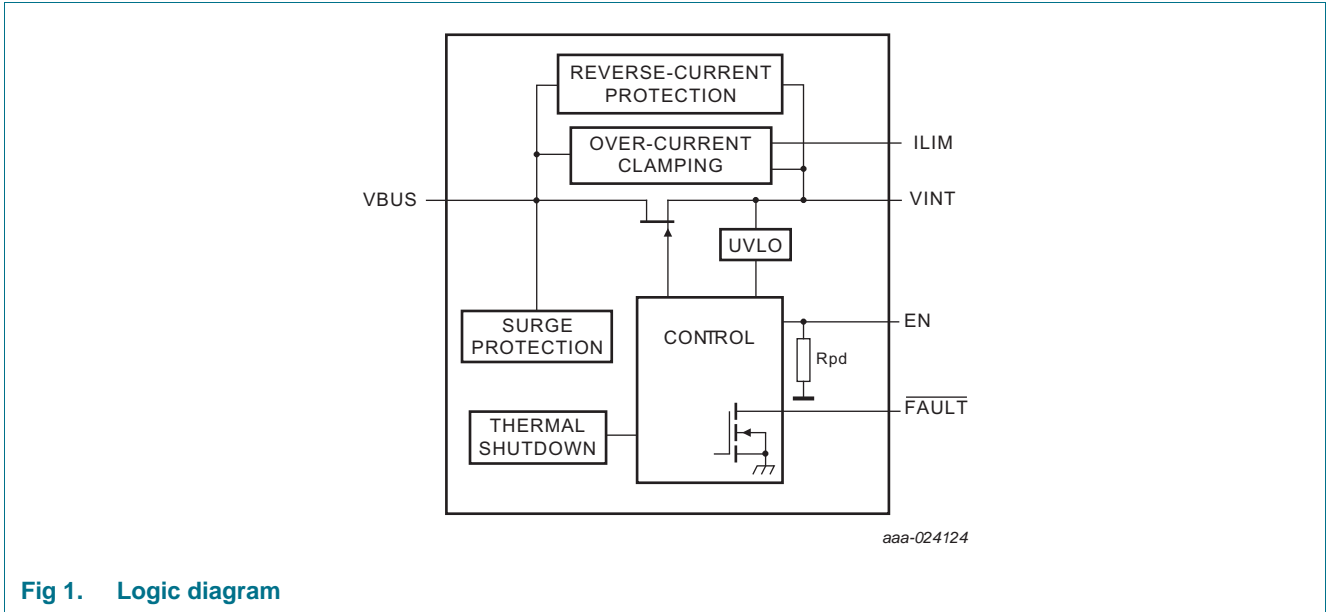
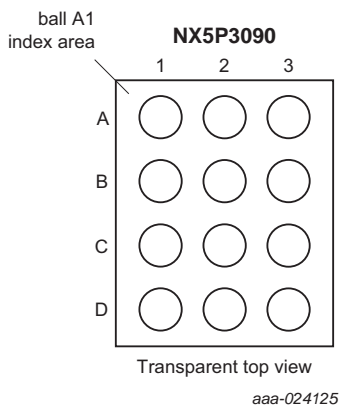

Fig 1. Logic diagram

## 7. Pinning information

### 7.1 Pinning



**Fig 2. Pin configuration**

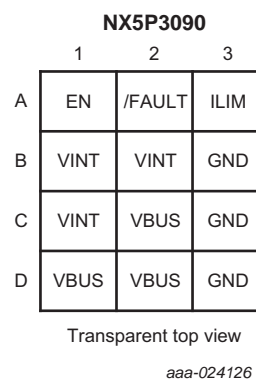

**Fig 3. Pin map**

### 7.2 Pin description

**Table 4. Pin description**

Symbol	Pin	Description
VBUS	C2, D1, D2	power output; 29 V tolerance
ILIM	A3	current limiter setting. connects a resistor to GND to set the threshold
$\overline{\text{FAULT}}$	A2	fault condition indicator (open-drain output)
EN	A1	enable input (active HIGH)
GND	B3, C3, D3	ground (0 V)
VINT	B1, C1, B2	power input

## 8. Functional description

Table 5. Function table<sup>[1]</sup>

EN	VINT	VBUS	FAULT	Switch
X	<2.5V	X	Z	under voltage lockout, switch open
L	2.5V to 5.5V	X	Z	disabled; switch open
H	2.5V to 5.5V	VBUS=VINT	Z	enabled; switch closed
H	2.5V to 5.5V	0V to VINT	L	over-current, clamped current output, switch closed
H	2.5V to 5.5V	VBUS>VINT+40mV (>4ms)	L	reverse current; switch open
H	2.5V to 5.5V	Z	L	Over-temperature; switch open

[1] H = HIGH voltage level; L = LOW voltage level.

### 8.1 EN Input

When the EN pin is set LOW, the N-channel MOSFET will be disabled, the device will enter low-power mode disabling all protection circuits and setting the FAULT pin high impedance. When EN is set HIGH, all protection circuits will be enabled and then, if no fault conditions exist, the N-channel MOSFET will be turn on. There is a 100 us de-glitch time on EN pin from LOW to HIGH.

### 8.2 Under-voltage lock-out

Independently of the logic level on the EN pin, the under-voltage lockout (UVLO) circuit disables the N-channel MOSFET and enters low power mode until the input voltage reaches the UVLO turn-on threshold level VUVLO.

### 8.3 ILIM

The over-current protection circuit's (OCP) trigger value  $I_{ocp}$  can be set using an external resistor  $R_{ILIM}$  connected between ILIM pin and GND pin. When EN is HIGH and the ILIM pin is pulled to ground, the N-channel MOSFET will be disabled and the FAULT output set LOW. The detailed IOCP setting is given in [Section 8.4](#).

### 8.4 Over-current protection (OCP)

The device offers over current protection when enabled, three possible over-current conditions can occur. These conditions are:

- Over-current at start-up,  $I_{SW} > I_{ocp}$  when enabling the N-channel MOSFET.
- Over-current after enabled,  $I_{SW} > I_{ocp}$  when the N-channel MOSFET is already ON.
- Short circuit after enabled,  $I_{SW} > 10$  A (typical).

In the over current condition, because the device clamps the output current rather than completely shut down the switch, the power dissipation on the device might be increased which could lead to over temperature protection (see [Section 8.7](#)).

#### 8.4.1 Over-current at start-up

If the device senses a VBUS short to GND or over-current while enabling the N-channel MOSFET, OCP is triggered. It limits the output current to  $I_{ocp}$  and after the de-glitch time sets the FAULT output LOW.

#### 8.4.2 Over-current when enabled

If the device senses  $I_{SW} > I_{ocp}$  after enabled, OCP is triggered. It limits the output current to  $I_{ocp}$  and after the de-glitch time sets the  $\overline{\text{FAULT}}$  output LOW. Limiting the output current reduces  $V_{O(VOUT)}$ .

#### 8.4.3 Short circuit when enabled

If the device senses  $I_{SW} > 10\text{ A}$  after enabled, a short circuit is detected. The device disables the N-channel MOSFET immediately. It then re-enables the N-channel MOSFET and limit the output current to  $I_{ocp}$ , and after the de-glitch time the  $\overline{\text{FAULT}}$  output is set LOW.

### 8.5 Reverse-Current protection (RCP)

When the VBUS pin voltage exceeds the input voltage by 40 mV (typical) the device will protect itself from damage by switching off the MOSFET after 4 ms de-glitch time.

When the VBUS pin voltage exceeds the VINT voltage by 100 mV, the device will shutdown the FET immediately without any de-glitch time.

FAULT pin will be set LOW in the reverse-current protection condition.

In the RCP state, when the VBUS voltage drops below VINT voltage, the device will exit the RCP state in 128 us and resume normal operation.

Before normal turn on, the device will always check the RCP condition first, if higher voltage is detected on VBUS pin, it will never turn on the power MOSFET even EN pin is pulled HIGH.

### 8.6 $\overline{\text{FAULT}}$ output

The  $\overline{\text{FAULT}}$  output is an open-drain output that requires an external pull-up resistor. If any of the protection circuits is activated, the  $\overline{\text{FAULT}}$  output will be set LOW to indicate a fault has occurred. The  $\overline{\text{FAULT}}$  output will return to the high impedance state automatically once the fault condition is removed. An internal delay (de-glitch) circuit for the over-current protection (8 ms typical) and reverse-current protection (4 ms typical) is used when entering fault conditions. This ensures that  $\overline{\text{FAULT}}$  is not accidentally asserted. Over-temperature condition will not be deglitched, the  $\overline{\text{FAULT}}$  signal will be asserted immediately.

### 8.7 Over-temperature protection

When EN is HIGH, the device junction temperature exceeds 140 °C, the over-temperature protection (OTP) circuit will disable the N-channel MOSFET and indicate a fault condition by setting the  $\overline{\text{FAULT}}$  pin LOW. Any transition on the EN pin will have no effect. Once the device temperature decreases below 115 °C the device will return to the defined state.

## 9. Application diagram

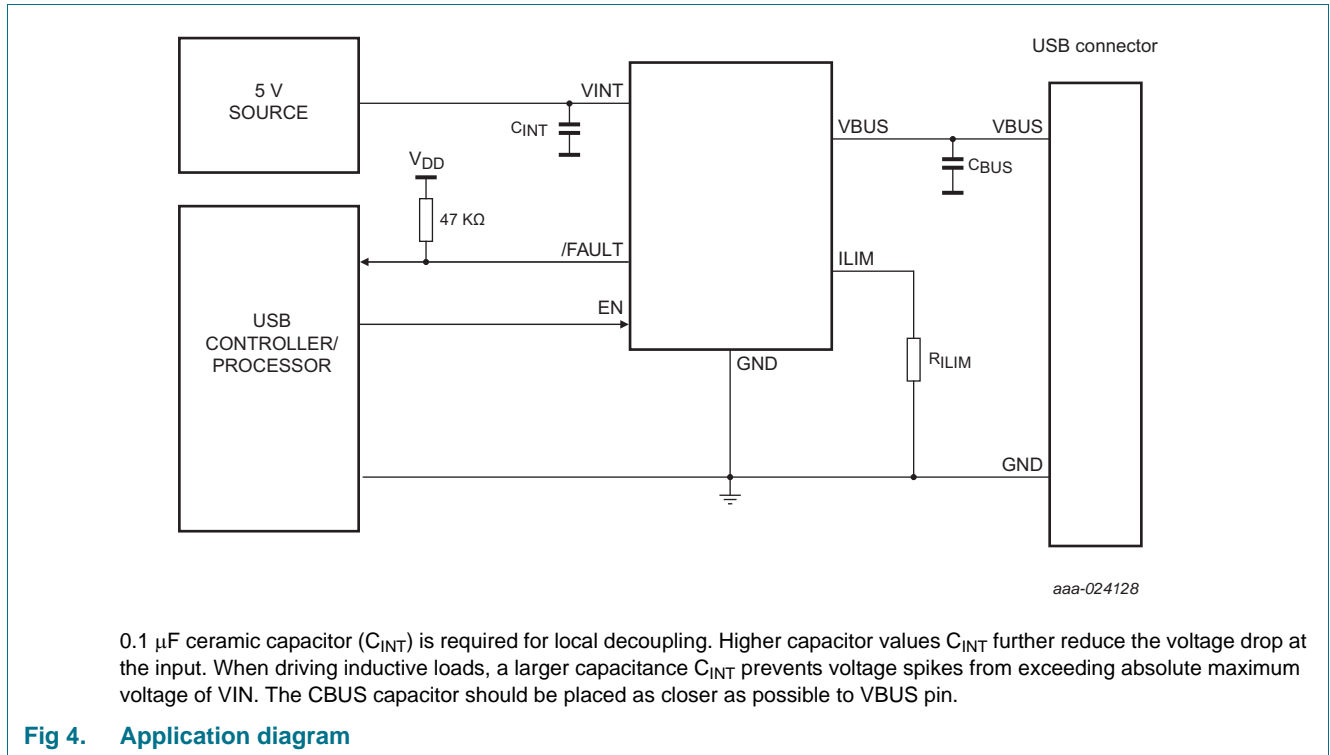

## 10. Limiting values

**Table 6. Limiting values**

In accordance with the Absolute Maximum Rating System (IEC 60134). Voltages are referenced to GND (ground = 0 V).

Symbol	Parameter	Conditions	Min	Max	Unit
V <sub>I</sub>	input voltage	VBUS, EN <a href="#">[1]</a>	-0.5	+29	V
		VINT <a href="#">[2]</a>	-0.5	+6	V
		ILIM	-0.5	+6	V
V <sub>O</sub>	output voltage	$\overline{\text{FAULT}}$ <a href="#">[1]</a>	-0.5	+6	V
I <sub>IK</sub>	input clamping current	input EN: V <sub>I(EN)</sub> < -0.5 V	-50	-	mA
		input ILIM: V <sub>I(ILIM)</sub> < -0.5 V	-50	-	mA
I <sub>I(source)</sub>	input source current	input IILIM	-	1	mA
I <sub>OK</sub>	output clamping current	V <sub>O</sub> < 0 V	-50	-	mA
I <sub>SK</sub>	switch clamping current	input VIN: V <sub>I(VIN)</sub> < -0.5 V	-50	-	mA
		output VOUT: V <sub>O(VOUT)</sub> < -0.5 V	-50	-	mA
I <sub>SW</sub>	switch current	V <sub>SW</sub> > -0.5 V <a href="#">[3]</a>	-	3.6	A
T <sub>j(max)</sub>	maximum junction temperature		-40	+150	°C
T <sub>stg</sub>	storage temperature		-65	+150	°C
P <sub>tot</sub>	total power dissipation	<a href="#">[4]</a>	-	910	mW

[1] The minimum input voltage rating may be exceeded if the input current rating is observed.

[2] The minimum and maximum switch voltage ratings may be exceeded if the switch clamping current rating is observed.

[3] Internally limited.

[4] The (absolute) maximum power dissipation depends on the junction temperature T<sub>j</sub>. Higher power dissipation is allowed in conjunction with lower ambient temperatures. The conditions to determine the specified values are T<sub>amb</sub> = 25 °C and the use of a two layer PCB.

## 11. Recommended operating conditions

**Table 7. Recommended operating conditions**

Symbol	Parameter	Conditions	Min	Max	Unit
V <sub>I</sub>	input voltage	VINT	2.5	5.5	V
		EN; VBUS (OFF state)	0	20	V
V <sub>O</sub>	Output voltage	VBUS	0	5	V
I <sub>SW</sub>	switch current	T <sub>j</sub> = -40 °C to +85 °C	0	3	A
I <sub>O(sink)</sub>	output sink current	output $\overline{\text{FAULT}}$	-10	-	mA
R <sub>ILIM</sub>	current limit resistance	input ILIM <a href="#">[1]</a>	16	140	kΩ
C <sub>dec</sub>	decoupling capacitance	VIN to GND	0.1	-	μF
T <sub>amb</sub>	ambient temperature		-40	+85	°C

[1] Current-limit threshold resistor range from ILIM to GND.

## 12. Thermal characteristics

**Table 8. Thermal characteristics**

Symbol	Parameter	Conditions	Typ	Unit
$R_{th(j-a)}$	thermal resistance from junction to ambient		[1] 109	K/W

[1]  $R_{th(j-a)}$  is dependent upon board layout. To minimize  $R_{th(j-a)}$ , ensure all pins have a solid connection to larger copper layer areas. In multi-layer PCBs, the second layer should be used to create a large heat spreader area below the device. Avoid using solder-stop varnish under the device.

## 13. Static characteristics

**Table 9. Static characteristics**

At recommended operating conditions;  $V_{I(VINT)} = V_{I(EN)}$ ,  $R_{FAULT} = 10\text{ k}\Omega$  unless otherwise specified; Voltages are referenced to GND (ground = 0 V). See [Figure 10](#)

Symbol	Parameter	Conditions	Min	Typ[1]	Max	Unit
$V_{IH}$	HIGH-level input voltage	EN input; $V_{I(VINT)} = 2.5\text{ V to }5.5\text{ V}$ ;	1.2	-	-	V
$V_{IL}$	LOW-level input voltage	EN input; $V_{I(VINT)} = 2.5\text{ V to }5.5\text{ V}$ ;	-	-	0.4	V
$I_I$	input leakage current	EN input; $V_{I(VINT)} = 5.0\text{ V}$ ;	-	-	7.5	$\mu\text{A}$
$I_{(VIN)}$	supply current	VBUS open; $V_{I(VINT)} = 5.0\text{ V}$				
		EN = GND (low power mode);	-	0.9	5	$\mu\text{A}$
		EN = $V_{I(VIN)}$ ; $R_{ILIM} = 33\text{ k}\Omega$	-	196	280	$\mu\text{A}$
		EN = $V_{I(VIN)}$ ; $R_{ILIM} = 16\text{ k}\Omega$	-	210	290	$\mu\text{A}$
$I_{S(OFF)}$	VBUS OFF-State leakage current	$V_{I(VINT)} = 5.0\text{ V}$ ; $V_{I(VBUS)} = 0\text{ V}$ ; EN = LOW	-	1	10	$\mu\text{A}$
	VINT OFF-state leakage current	$V_{I(VBUS)} = 5.0\text{ V}$ ; $V_{I(VINT)} = 0\text{ V}$ ; EN = LOW	-	1	10	$\mu\text{A}$
$I_{S(ON)}$	RCP leakage current	$V_{I(VINT)} = 0\text{ V}$ ; $V_{I(VBUS)} = 5\text{ V}$ ; EN = 5 V	-	0.9	10	$\mu\text{A}$
Rpd	EN pin Pull-down resistance	$V_{I(VINT)} = 5\text{ V}$		1		M $\Omega$
$V_{trip}$	trip level voltage	RCP; $V_{I(VINT)} = 2.5\text{ V to }5.5\text{ V}$	-	40	-	mV
$V_{UVLO}$	under voltage lockout voltage	VINT pin	-	2.27	2.45	V
$V_{hys(UVLO)}$	under voltage lockout hysteresis voltage		-	100	-	mV
$V_{OL}$	LOW-level output voltage	$\overline{\text{FAULT}}$ ; $I_O = 8\text{ mA}$	-	-	0.5	V
Cl	EN pin		-	13.5	-	pF

[1] Typical values are measured at  $T_{amb} = 25\text{ }^\circ\text{C}$ .

13.1 Graphs

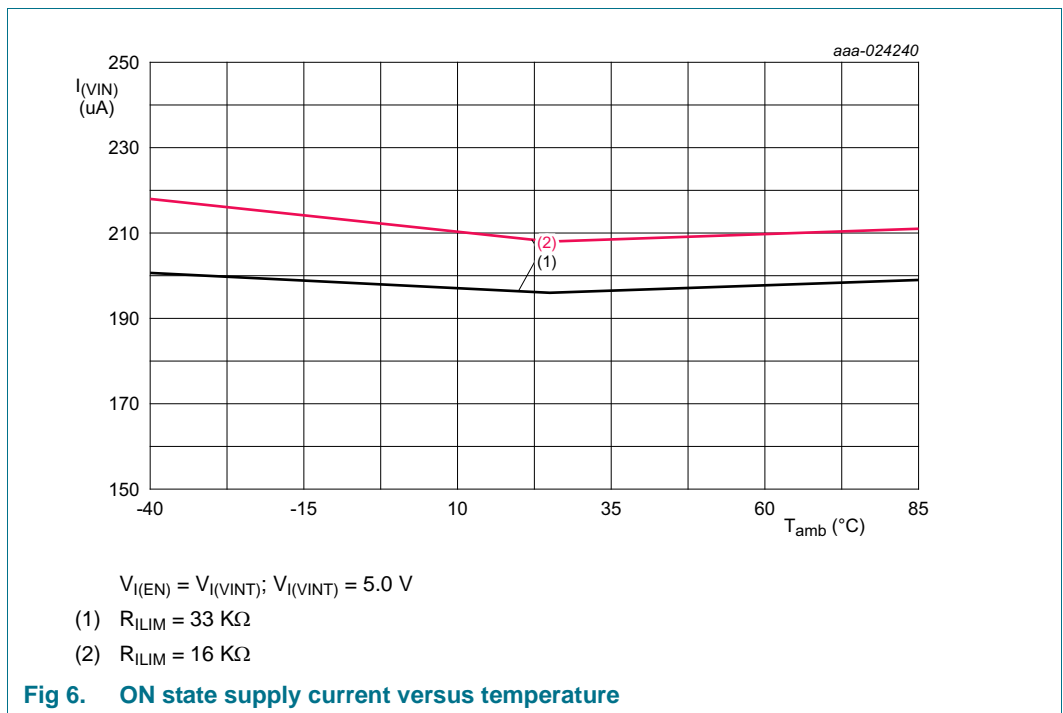
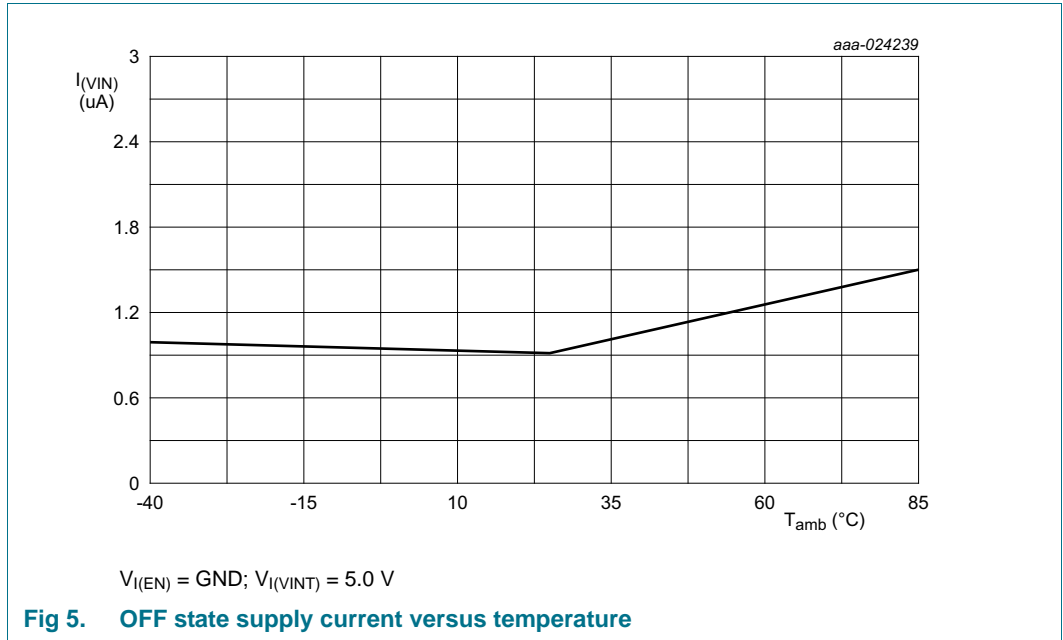

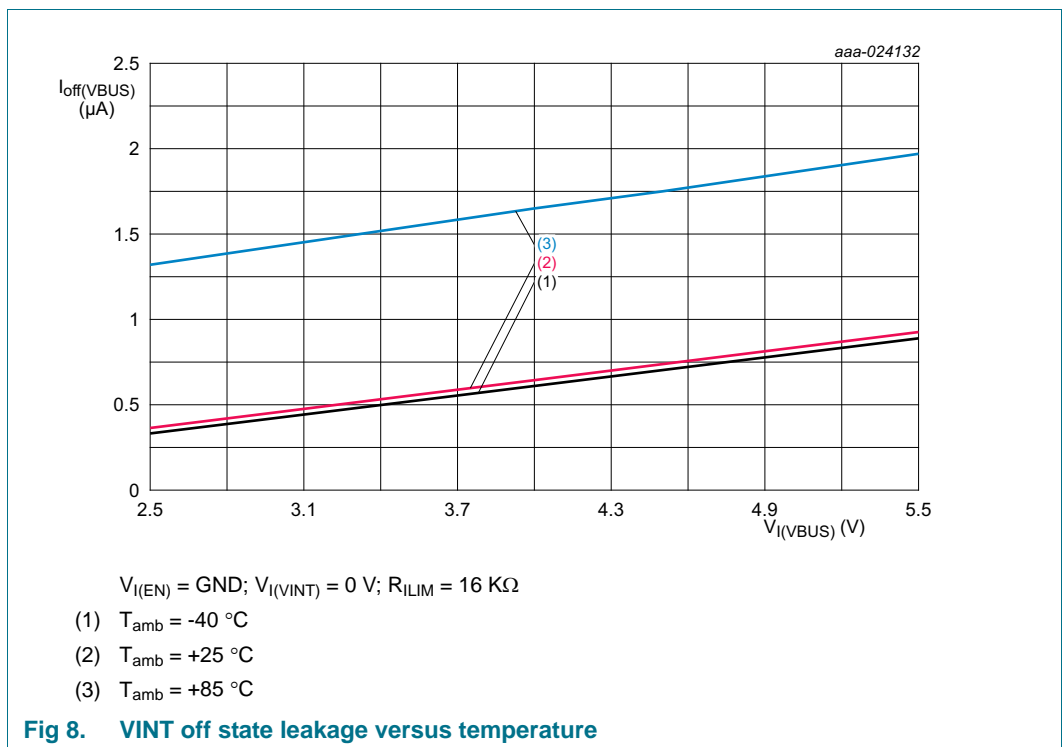
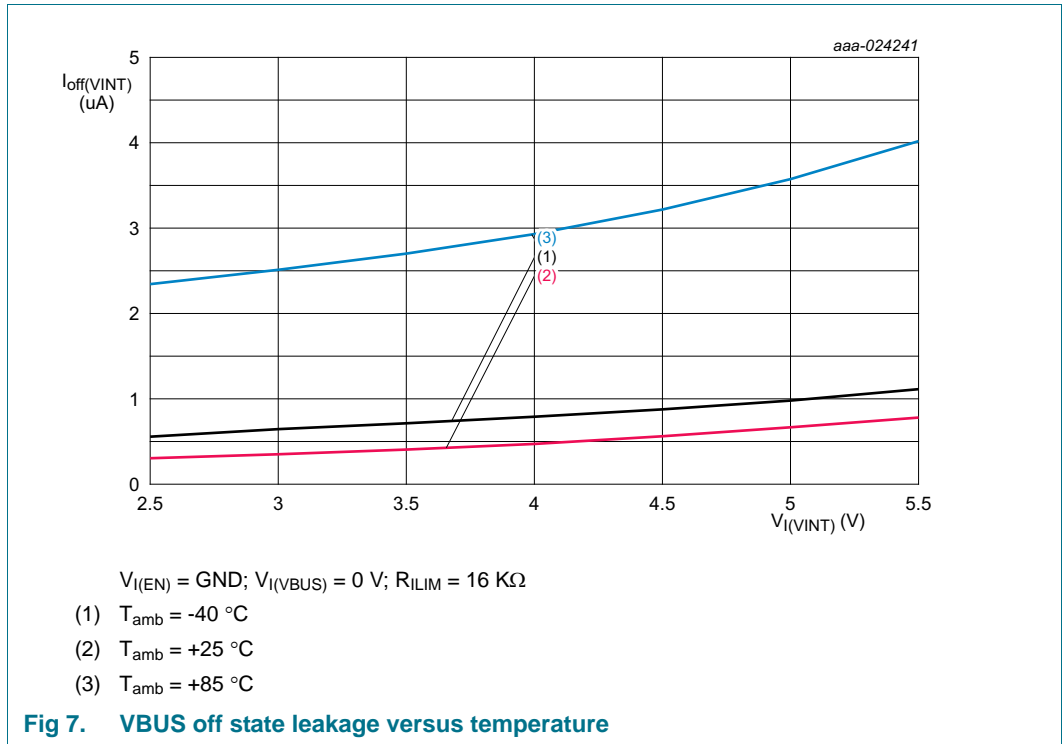

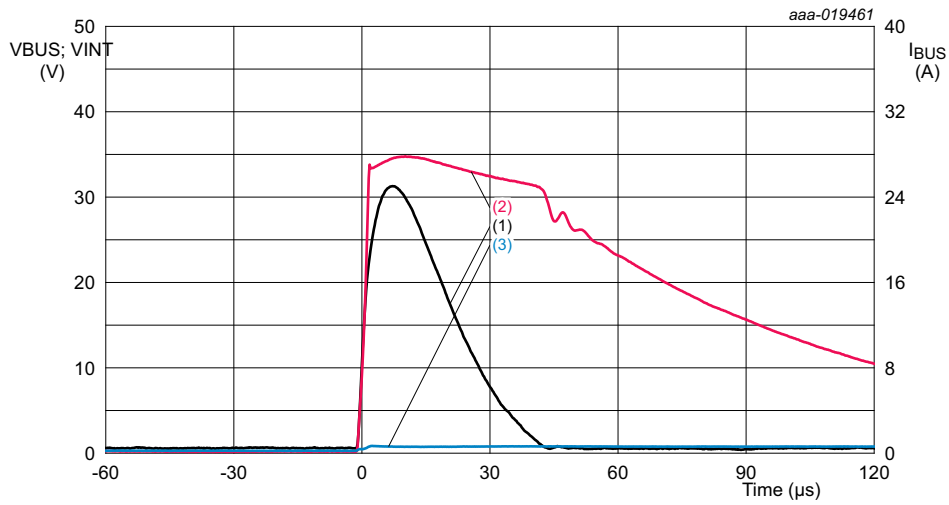

$R_{ILIM} = 20\text{ k}\Omega$ ;  $V_{I(VINT)} = 0\text{ V}$   
 (1) Surge current  
 (2) Surge voltage on VBUS

Fig 9. Surge protection waveform

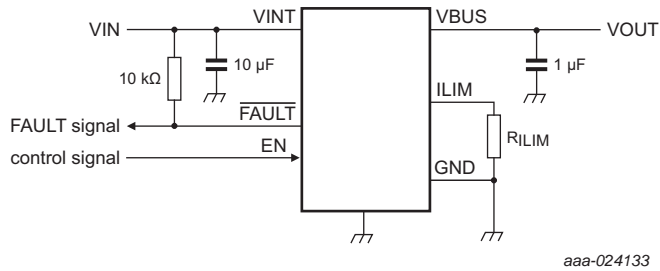

Fig 10. Typical characteristics reference schematic

### 13.2 Thermal shutdown

Table 10. Thermal shutdown

$V_{I(VINT)} = V_{I(EN)}$ ,  $R_{FAULT} = 10\text{ k}\Omega$  unless otherwise specified; Voltages are referenced to GND (ground = 0 V).

Symbol	Parameter	Conditions	Min	Typ	Max	Unit
$T_{th(ots)}$	over temperature shutdown threshold temperature	$V_{I(VINT)} = 2.5\text{ to }5.5\text{ V}$	-	140	-	°C
$T_{th(otp)hys}$	hysteresis of over temperature protection threshold temperature	$V_{I(VINT)} = 2.5\text{ to }5.5\text{ V}$	-	25	-	°C

### 13.3 ON resistance

**Table 11. ON resistance**

$V_{I(VINT)} = V_{I(EN)}$ ,  $R_{FAULT} = 10\text{ k}\Omega$  unless otherwise specified; Voltages are referenced to GND (ground = 0 V). See [Figure 10](#)

Symbol	Parameter	Conditions	Min	Typ	Max	Unit
R <sub>ON</sub>	ON resistance	$V_{I(VINT)} = 2.5\text{ to }5.5\text{ V}$ ; see <a href="#">Figure 11</a>				
		$T_{amb} = 25\text{ }^\circ\text{C}$	-	34	37	mΩ
		$T_{amb} = -40\text{ }^\circ\text{C to }+85\text{ }^\circ\text{C}$	-	-	46	mΩ

### 13.4 ON resistance graphs

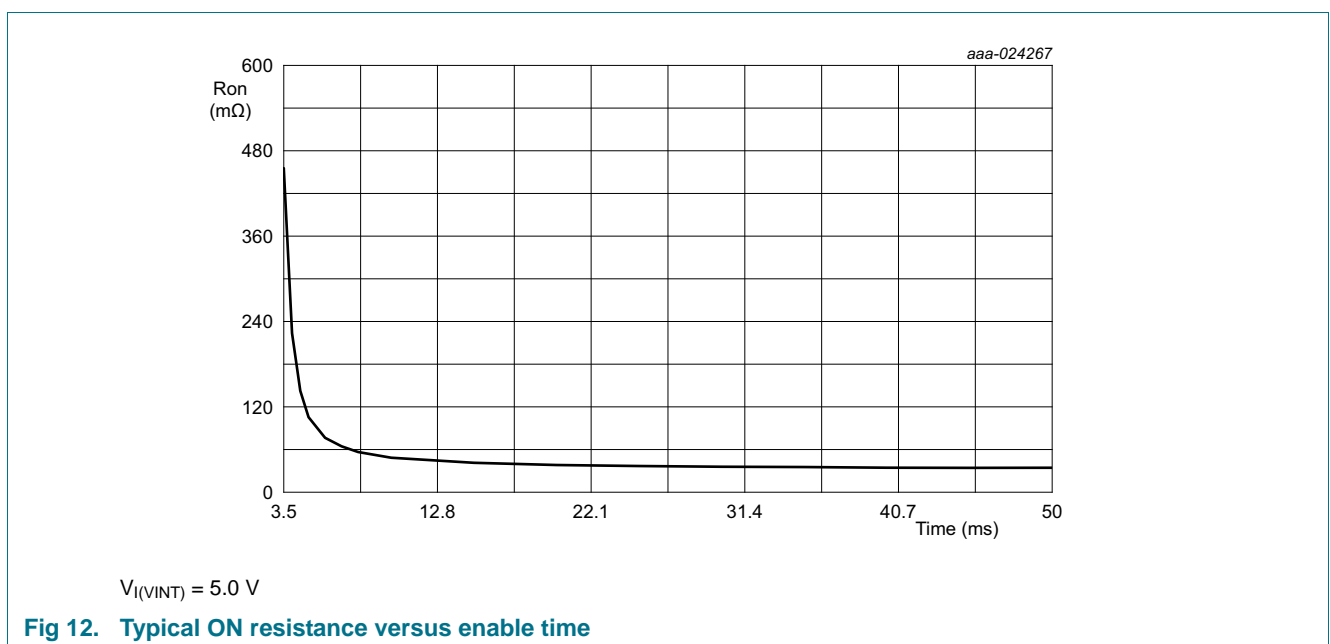
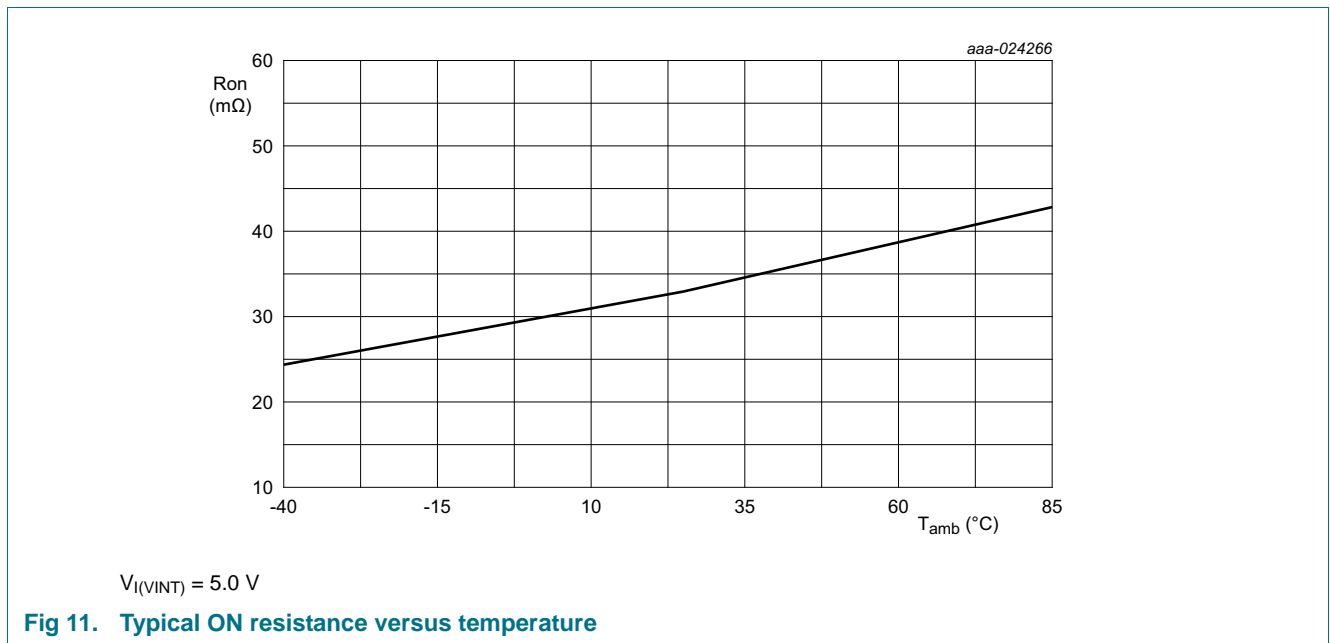

### 13.5 Current limit

**Table 12. Current limit**

$V_{I(VINT)} = V_{I(EN)}$ ,  $R_{FAULT} = 10\text{ k}\Omega$  unless otherwise specified; Voltages are referenced to GND (ground = 0 V). See [Figure 10](#)

Symbol	Parameter	Conditions	Min	Typ <sup>[1]</sup>	Max	Unit
$I_{ocp}$	over current protection current	$V_{I(VINT)} = 2.5\text{ to }5.5\text{ V}$ ; $T_{amb} = -40\text{ }^{\circ}\text{C to }+85\text{ }^{\circ}\text{C}$ ;				
		$R_{ILIM} = 140\text{ k}\Omega$	330	421	465	mA
		$R_{ILIM} = 100\text{ k}\Omega$	480	581	625	mA
		$R_{ILIM} = 54\text{ k}\Omega$	915	1057	1107	mA
		$R_{ILIM} = 33\text{ k}\Omega$	1505	1723	1780	mA
		$R_{ILIM} = 24.5\text{ k}\Omega$	2085	2330	2398	mA
		$R_{ILIM} = 20\text{ k}\Omega$	2567	2848	2920	mA
		$R_{ILIM} = 16\text{ k}\Omega$	3186	3490	3585	mA
	ILIM shorted to VINT	125	180	220	mA	

[1] Typical values are measured at  $T_{amb} = 25\text{ }^{\circ}\text{C}$ . 1 % tolerance resistor is recommend for  $R_{ILIM}$

$I_{ocp}$  can be calculated with below equation,  $x = R_{ILIM}$  (k $\Omega$ ):

$$I_{OCP(MAX)} = 49495x^{-0.948} \tag{1}$$

$$I_{OCP(TYP)} = 52775x^{-0.979} \tag{2}$$

$$I_{OCP(MIN)} = 57949x^{-1.042} \tag{3}$$

### 13.6 Current limit graphs

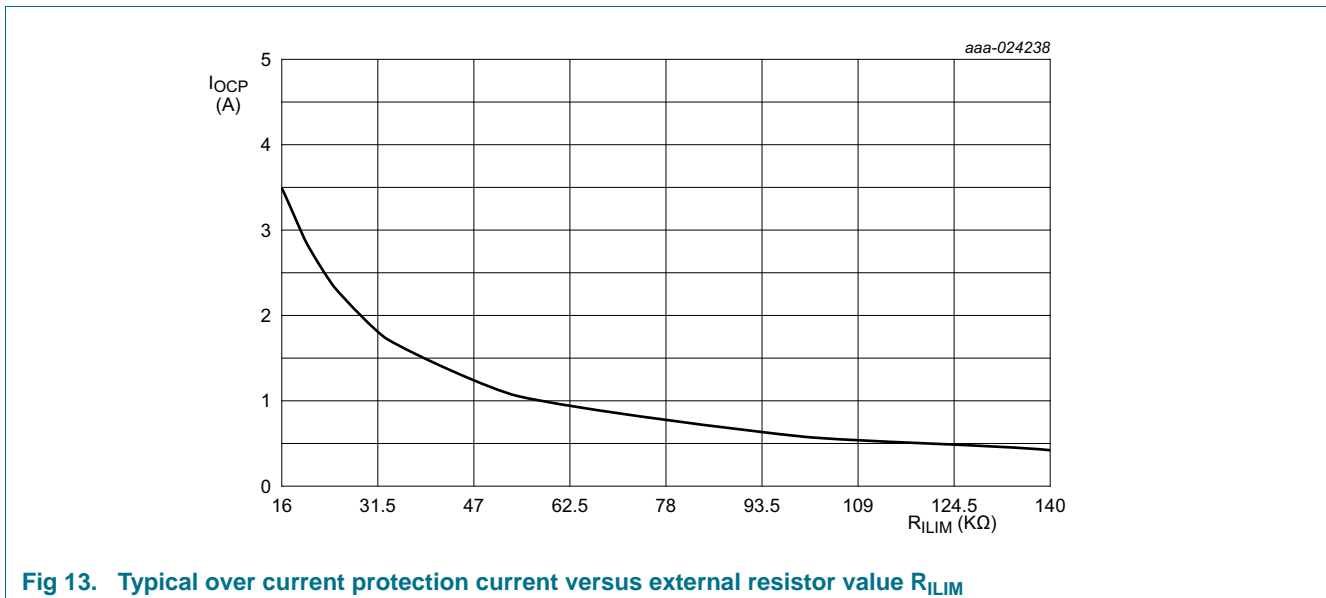

**Fig 13. Typical over current protection current versus external resistor value  $R_{ILIM}$**

## 14. Dynamic characteristics

**Table 13. Dynamic characteristics**

At recommended operating conditions;  $V_{I(VINT)} = V_{I(EN)}$ ,  $R_{FAULT} = 10\text{ k}\Omega$  unless otherwise specified; voltages are referenced to GND (ground = 0 V).

Symbol	Parameter	Conditions	Min	Typ <sup>[1]</sup>	Max	Unit
$t_{TLH}$	LOW to HIGH output transition time	$V_{OUT}$ ; $C_L = 1\ \mu\text{F}$ ; $R_L = 100\ \Omega$ ; see <a href="#">Figure 14</a> and <a href="#">Figure 15</a>				
		$V_{I(VINT)} = 5.0\ \text{V}$	-	2.5	-	ms
		$V_{I(VINT)} = 2.5\ \text{V}$	-	1.4	-	ms
$t_{THL}$	HIGH to LOW output transition time	$V_{OUT}$ ; $C_L = 1\ \mu\text{F}$ ; $R_L = 100\ \Omega$ ; see <a href="#">Figure 14</a> and <a href="#">Figure 15</a>				
		$V_{I(VINT)} = 5.0\ \text{V}$	-	0.2	-	ms
		$V_{I(VINT)} = 2.5\ \text{V}$	-	0.2	-	ms
$t_{en}$	enable time	EN to $V_{OUT}$ ; $C_L = 1\ \mu\text{F}$ ; $R_L = 100\ \Omega$ ; see <a href="#">Figure 14</a> and <a href="#">Figure 15</a>				
		$V_{I(VINT)} = 5.0\ \text{V}$	-	1.5	-	ms
$t_{dis}$	disable time	EN to $V_{OUT}$ ; $C_L = 1\ \mu\text{F}$ ; $R_L = 100\ \Omega$ ; see <a href="#">Figure 14</a> and <a href="#">Figure 15</a>				
		$V_{I(VINT)} = 5.0\ \text{V}$	-	13	-	$\mu\text{s}$
$t_{degl}$	deglitch time	FAULT in OCP; $V_{I(VINT)} = 5\ \text{V}$	-	8	-	ms
		RCP; FAULT in RCP; $V_{I(VINT)} = 5\ \text{V}$	-	4	-	ms

[1] Typical values are measured at  $T_{amb} = 25\ ^\circ\text{C}$ .

### 14.1 Waveform and test circuits

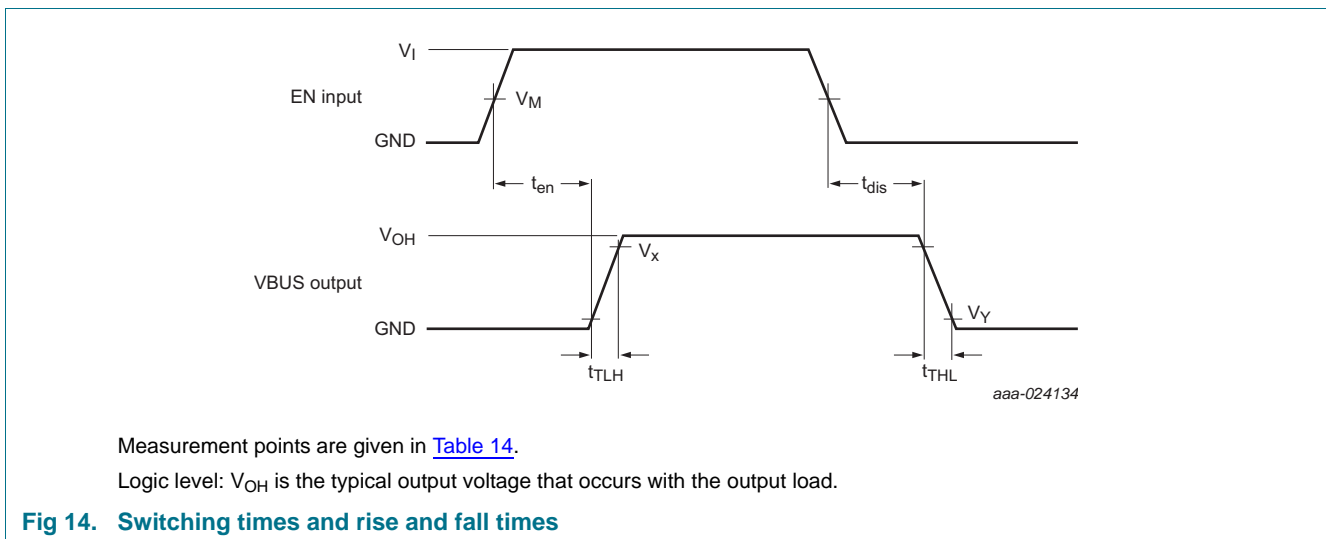

**Table 14. Measurement points**

Supply voltage	EN Input	Output	
$V_{I(VIN)}$	$V_M$	$V_X$	$V_Y$
5.0 V	$0.5 \times V_{I(EN)}$	$0.9 \times V_{OH}$	$0.1 \times V_{OH}$

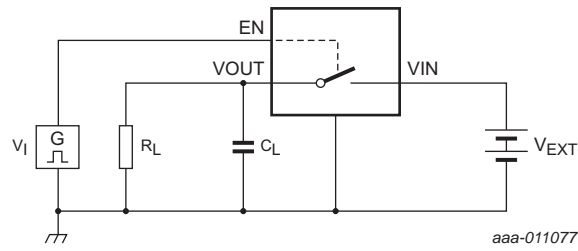

Test data is given in [Table 15](#).

Definitions test circuit:

$R_L$  = Load resistance.

$C_L$  = Load capacitance including jig and probe capacitance.

$V_{EXT}$  = External voltage for measuring switching times.

**Fig 15. Test circuit for measuring switching times**

**Table 15. Test data**

Supply voltage	EN Input	Load	
$V_{EXT}$	$V_{I(EN)}$	$C_L$	$R_L$
5.0 V	0 to $V_{I(VIN)}$	1 $\mu$ F	100 $\Omega$

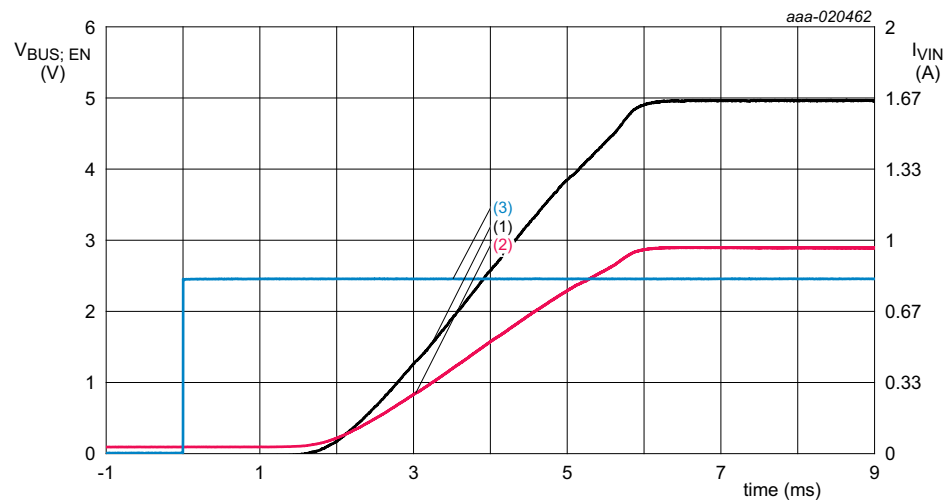

$V_{I(VINT)} = 5 \text{ V}; R_L = 5.1 \text{ } \Omega; C_L = 1 \text{ } \mu\text{F};$

(1)  $V_O(V_{BUS})$

(2)  $I_{(VIN)}$

(3)  $V_{I(EN)}$

**Fig 16. Typical 1  $\mu$ F load enable time and inrush current**

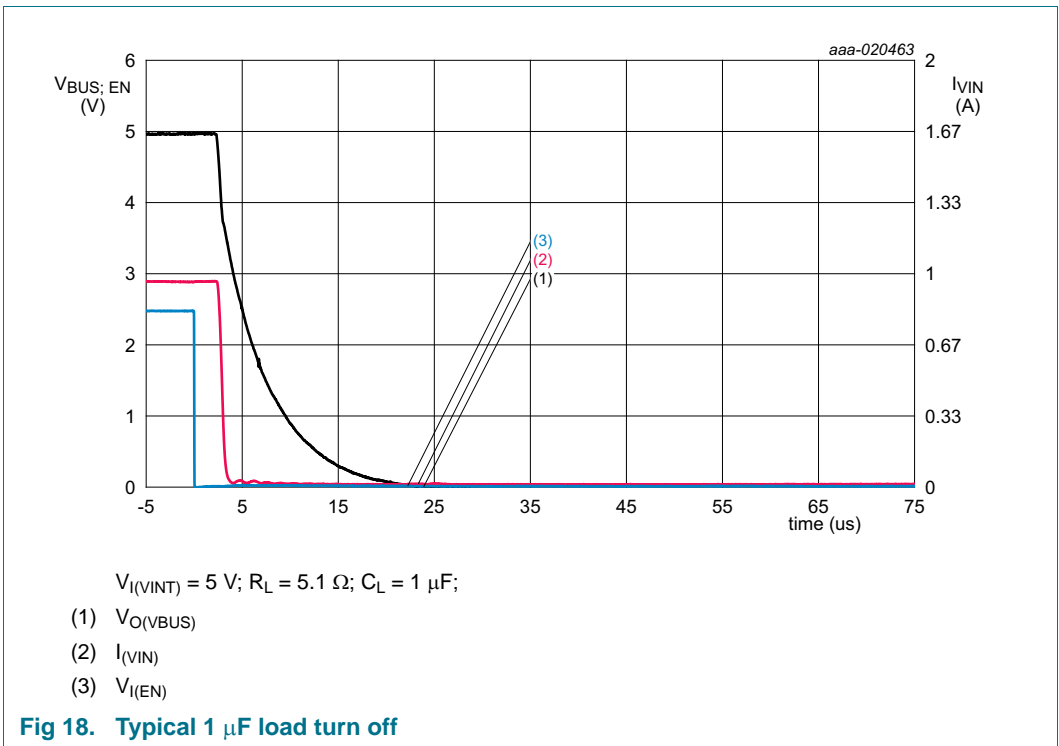
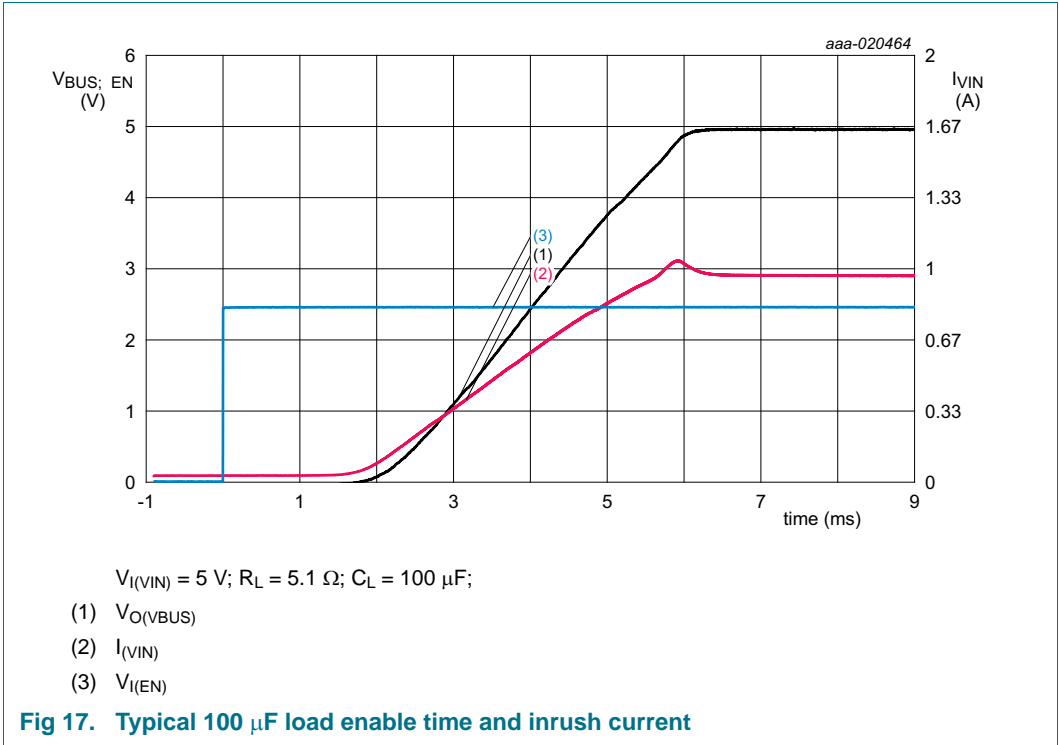

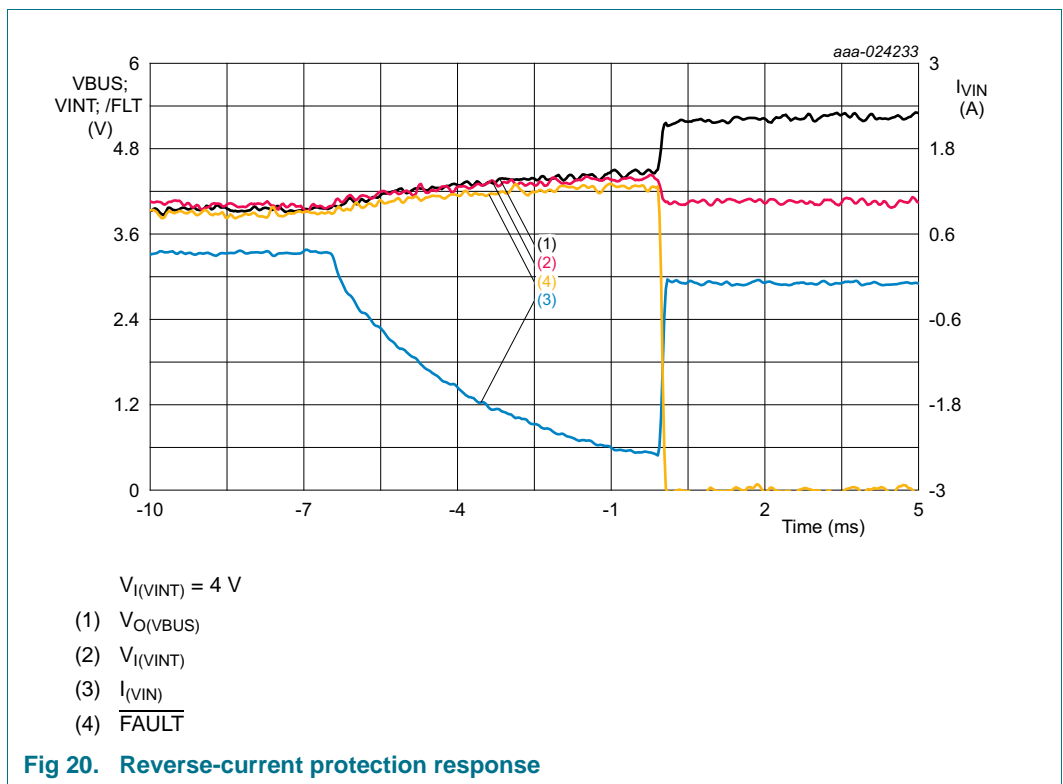
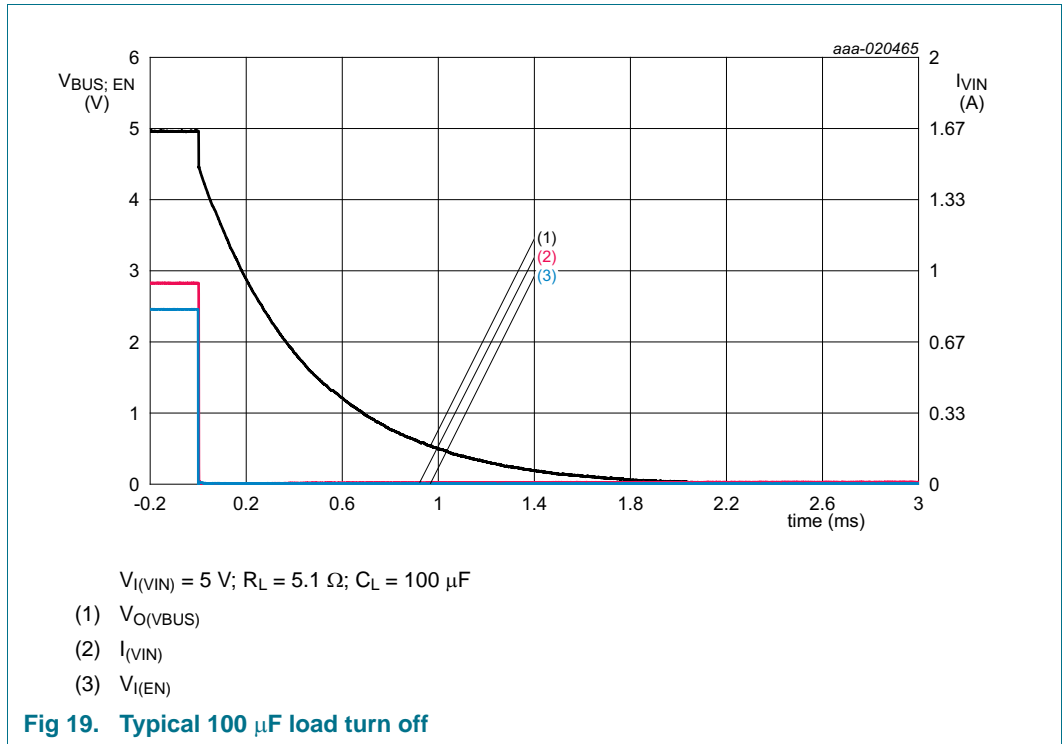

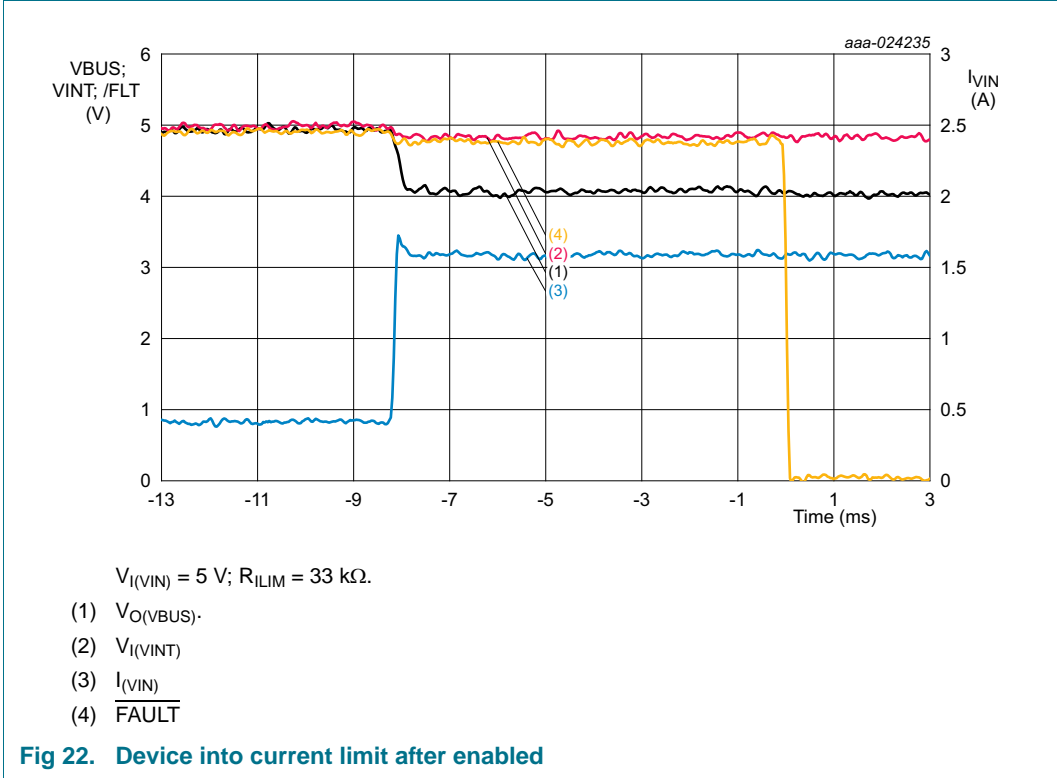
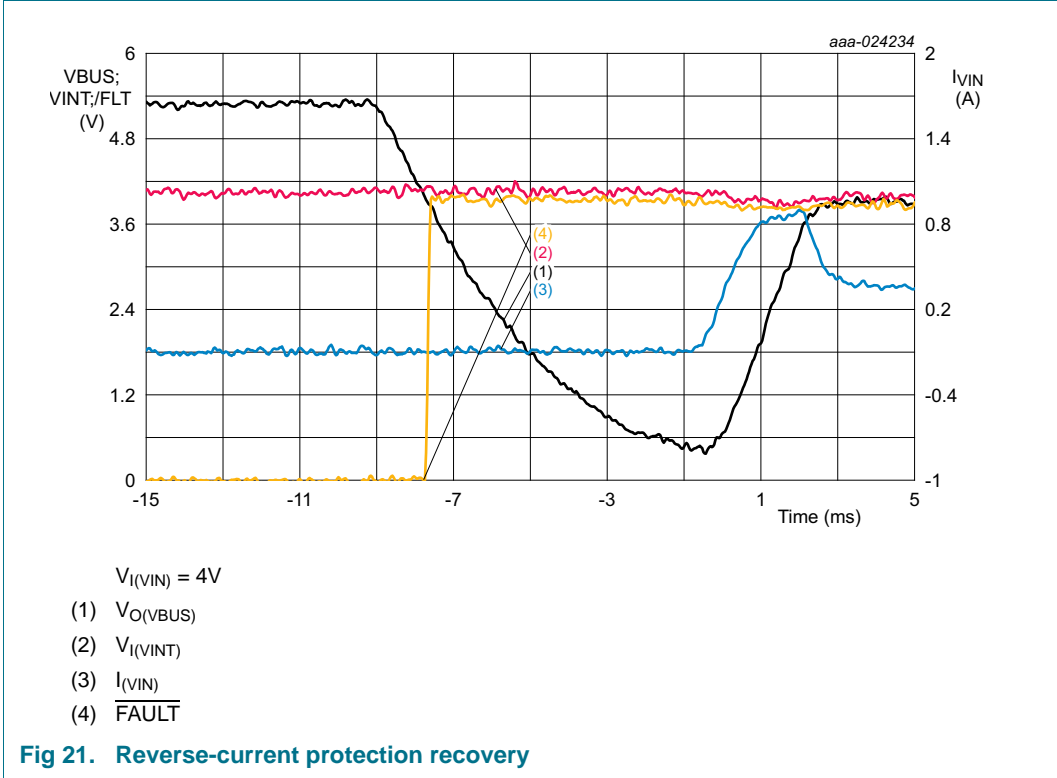

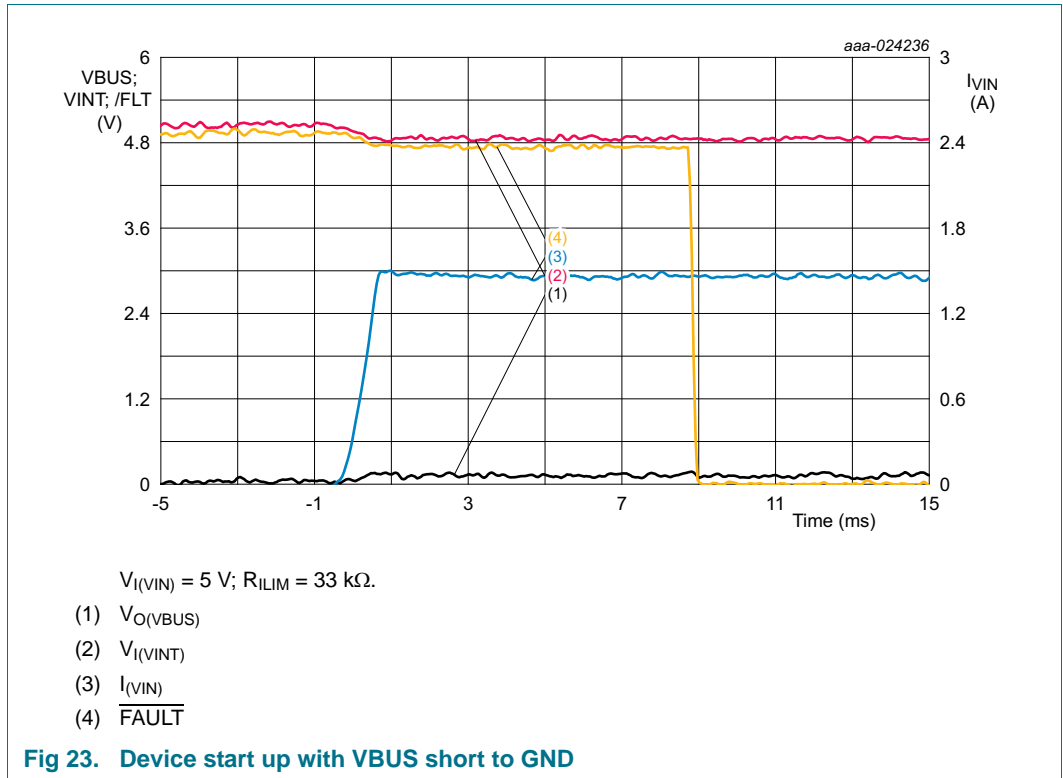

15. Package outline

WLCSP12: wafer level chip-scale package;  
12 bumps; 1.65 x 1.35 x 0.525 mm (Backside coating included)

SOT1390-5

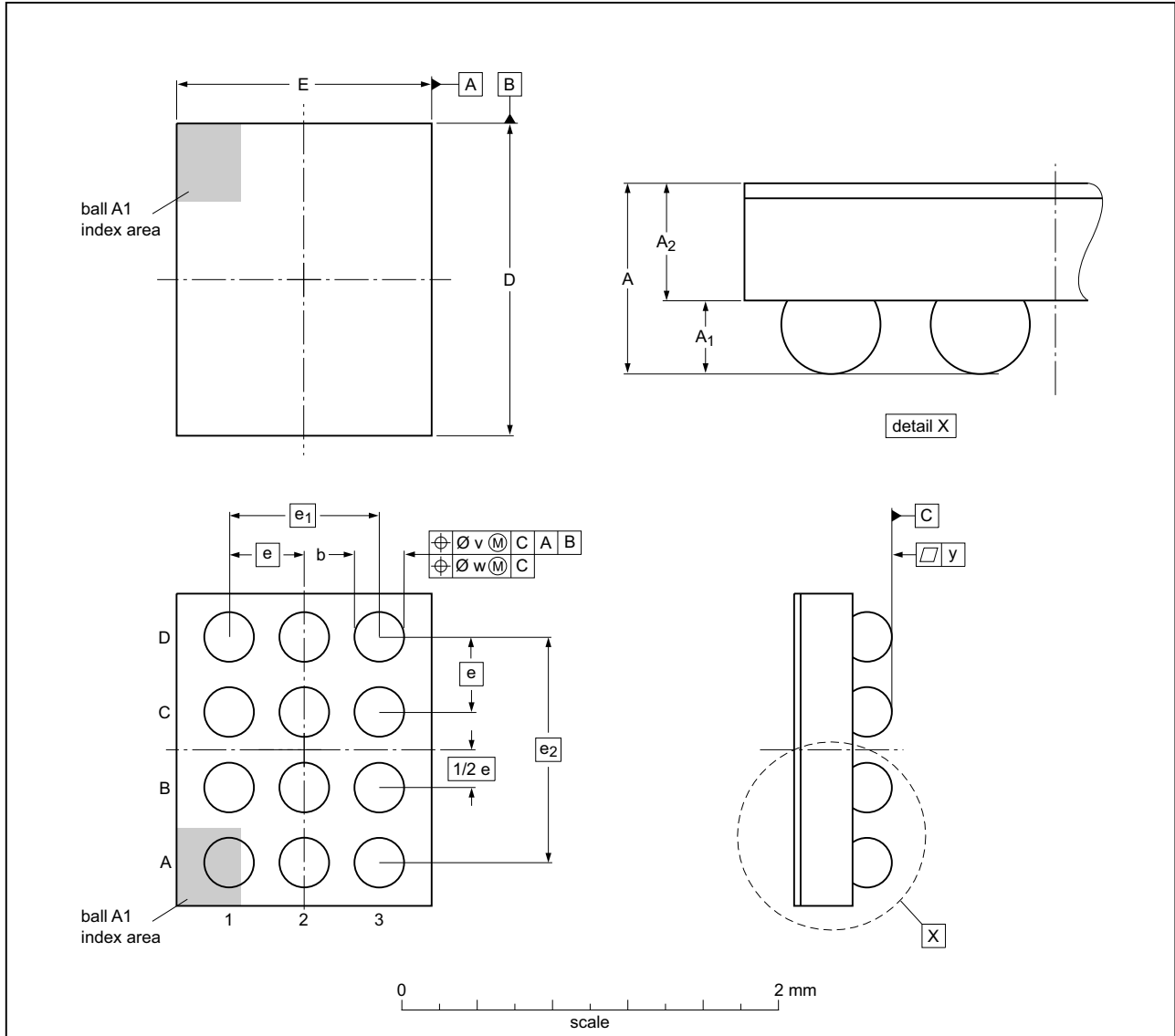

Dimensions (mm are the original dimensions)

Unit	A	A <sub>1</sub>	A <sub>2</sub>	b	D	E	e	e <sub>1</sub>	e <sub>2</sub>	v	w	y
max	0.565	0.23	0.350	0.29	1.68	1.38						
nom	0.525	0.20	0.325	0.26	1.65	1.35	0.4	0.8	1.2	0.05	0.15	0.03
min	0.485	0.17	0.300	0.23	1.62	1.32						

Note: Backside coating 25 µm

sot1390-5\_po

Outline version	References			European projection	Issue date
	IEC	JEDEC	JEITA		
SOT1390-5		---			<del>15-07-15</del> 15-11-03

Fig 24. Package outline WLCSP12

## 16. Packing information

### 16.1 Packing method

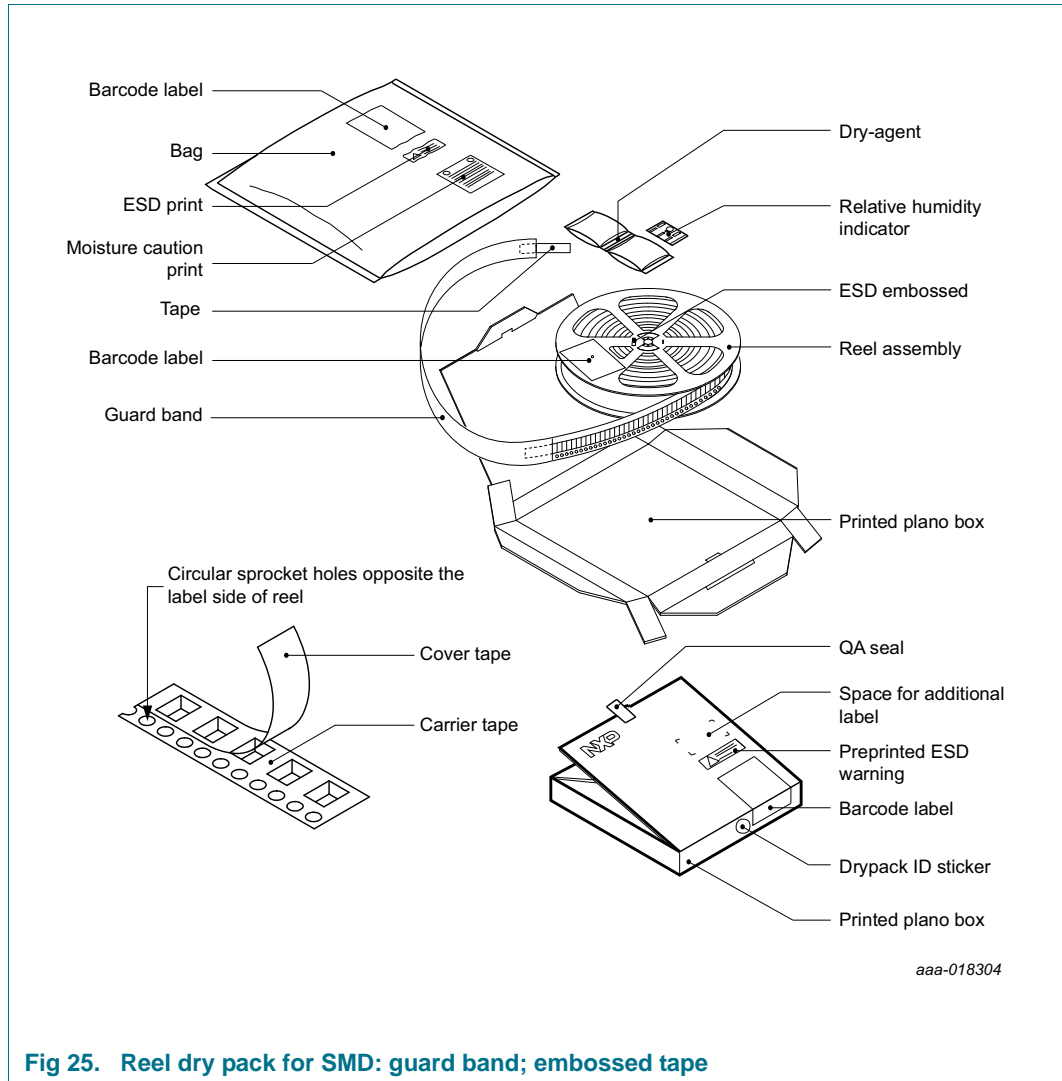

**Table 16. Dimensions and quantities**

Reel dimensions d × w (mm) [1]	SPQ/PQ (pcs) [2]	Reels per box	Outer box dimensions l × w × h (mm)
180 × 8	3000	1	209 × 206 × 34

[1] d = reel diameter; w = tape width.

[2] Packing quantity dependent on specific product type.

View ordering and availability details at [NXP order portal](#), or contact your local NXP representative.

## 16.2 Product orientation

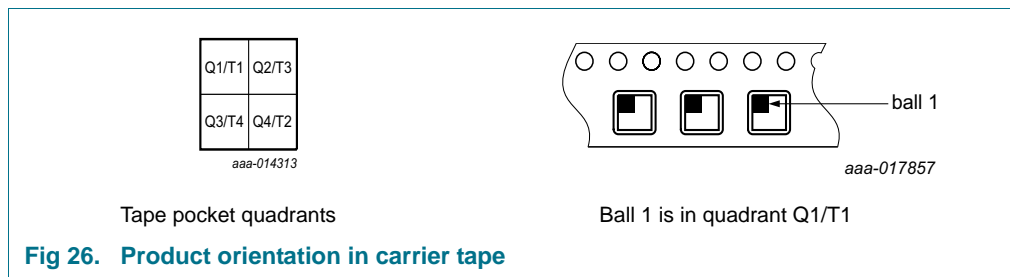

**Fig 26. Product orientation in carrier tape**

## 16.3 Carrier tape dimensions

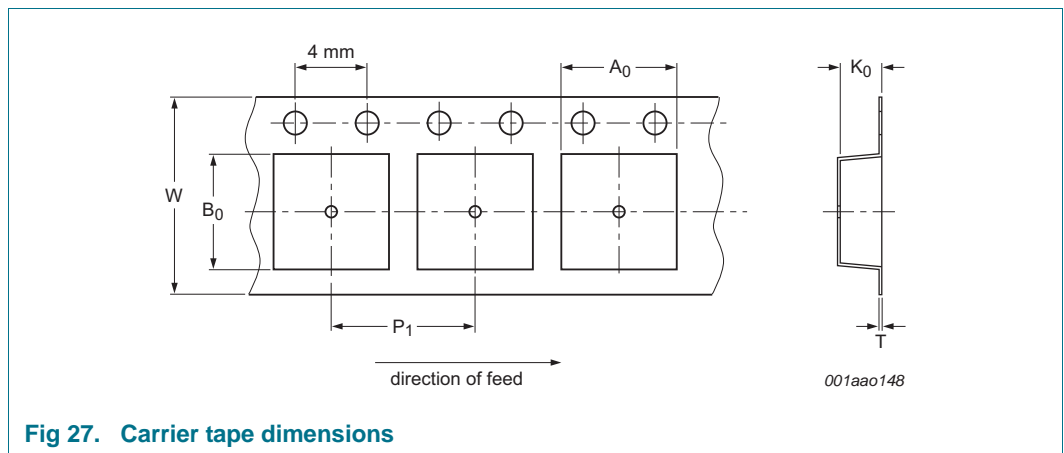

**Fig 27. Carrier tape dimensions**

**Table 17. Carrier tape dimensions**

In accordance with IEC 60286-3.

A <sub>0</sub> (mm)	B <sub>0</sub> (mm)	K <sub>0</sub> (mm)	T (mm)	P <sub>1</sub> (mm)	W (mm)
1.61 ± 0.05	1.78 ± 0.05	0.73 ± 0.05	0.25 ± 0.02	4.0 ± 0.1	8 + 0.3 / - 0.1

**16.4 Reel dimensions**

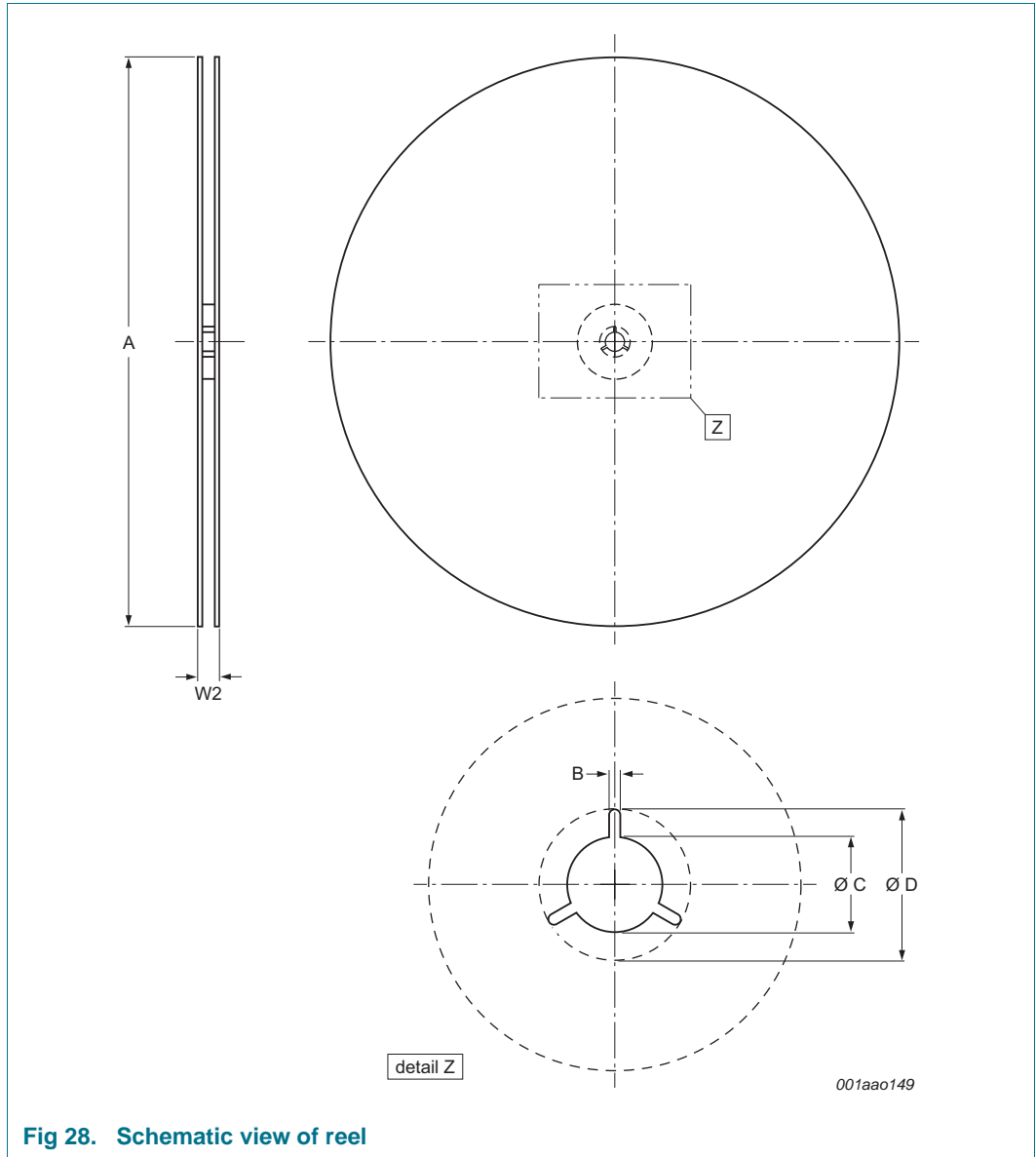

**Fig 28. Schematic view of reel**

**Table 18. Reel dimensions**  
 In accordance with IEC 60286-3.

<b>A [nom] (mm)</b>	<b>W2 [max] (mm)</b>	<b>B [min] (mm)</b>	<b>C [min] (mm)</b>	<b>D [min] (mm)</b>
180	14.4	1.5	12.8	20.2

16.5 Barcode label

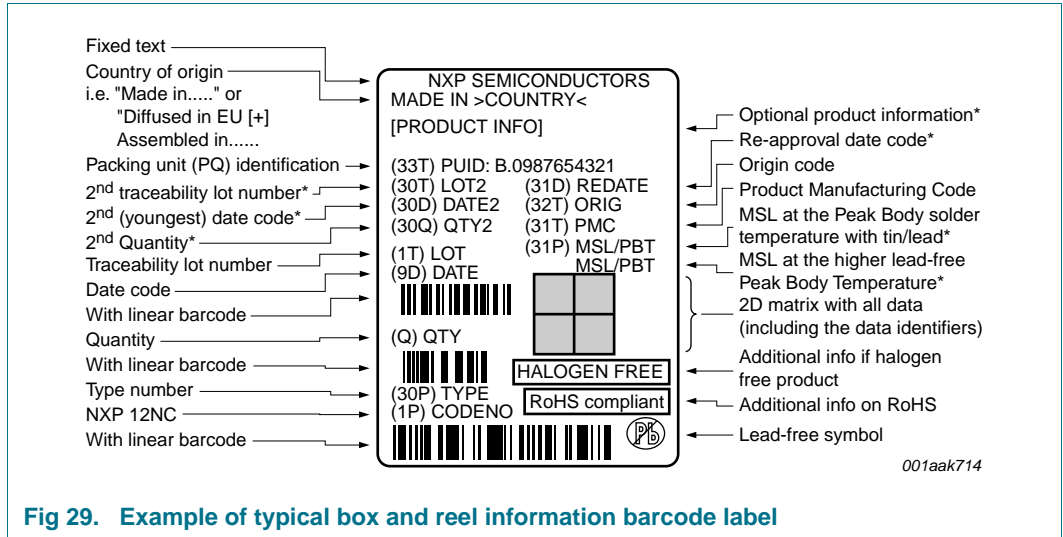

Fig 29. Example of typical box and reel information barcode label

Table 19. Barcode label dimensions

Box barcode label l × w (mm)	Reel barcode label l × w (mm)
100 × 75	100 × 75

## 17. Soldering of WLCSP packages

### 17.1 Introduction to soldering WLCSP packages

This text provides a very brief insight into a complex technology. A more in-depth account of soldering WLCSP (Wafer Level Chip-Size Packages) can be found in application note AN10439 "Wafer Level Chip Scale Package" and in application note AN10365 "Surface mount reflow soldering description".

Wave soldering is not suitable for this package.

All NXP WLCSP packages are lead-free.

### 17.2 Board mounting

Board mounting of a WLCSP requires several steps:

1. Solder paste printing on the PCB
2. Component placement with a pick and place machine
3. The reflow soldering itself

### 17.3 Reflow soldering

Key characteristics in reflow soldering are:

- Lead-free versus SnPb soldering; note that a lead-free reflow process usually leads to higher minimum peak temperatures (see [Figure 30](#)) than a SnPb process, thus reducing the process window
- Solder paste printing issues, such as smearing, release, and adjusting the process window for a mix of large and small components on one board
- Reflow temperature profile; this profile includes preheat, reflow (in which the board is heated to the peak temperature), and cooling down. It is imperative that the peak temperature is high enough for the solder to make reliable solder joints (a solder paste characteristic) while being low enough that the packages and/or boards are not damaged. The peak temperature of the package depends on package thickness and volume and is classified in accordance with [Table 20](#).

**Table 20. Lead-free process (from J-STD-020D)**

Package thickness (mm)	Package reflow temperature (°C)		
	Volume (mm <sup>3</sup> )		
	< 350	350 to 2000	> 2000
< 1.6	260	260	260
1.6 to 2.5	260	250	245
> 2.5	250	245	245

Moisture sensitivity precautions, as indicated on the packing, must be respected at all times.

Studies have shown that small packages reach higher temperatures during reflow soldering, see [Figure 30](#).

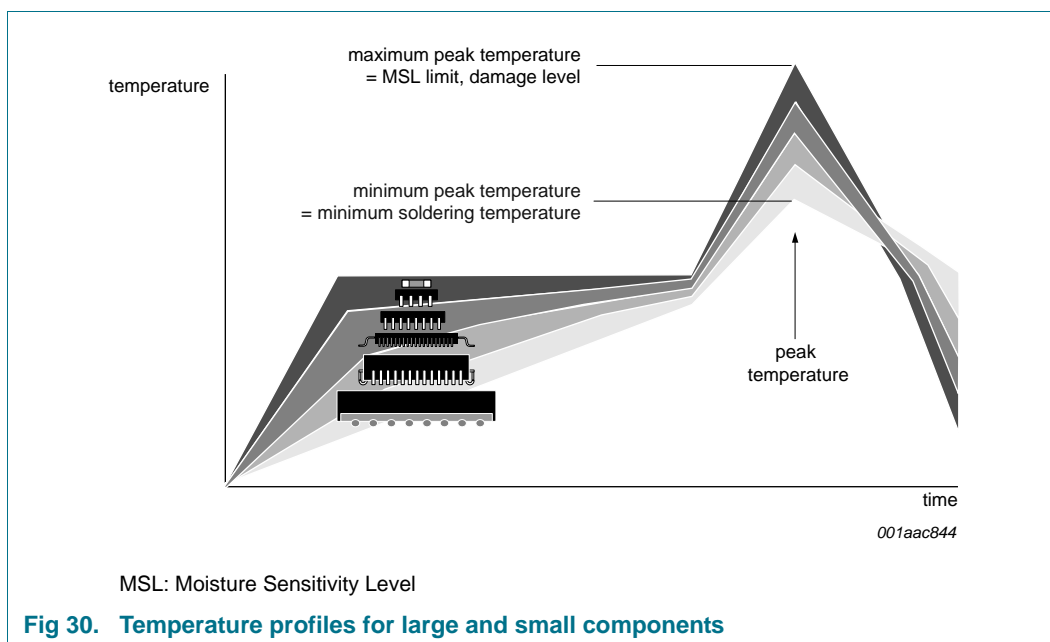

For further information on temperature profiles, refer to application note *AN10365 "Surface mount reflow soldering description"*.

### 17.3.1 Stand off

The stand off between the substrate and the chip is determined by:

- The amount of printed solder on the substrate
- The size of the solder land on the substrate
- The bump height on the chip

The higher the stand off, the better the stresses are released due to TEC (Thermal Expansion Coefficient) differences between substrate and chip.

### 17.3.2 Quality of solder joint

A flip-chip joint is considered to be a good joint when the entire solder land has been wetted by the solder from the bump. The surface of the joint should be smooth and the shape symmetrical. The soldered joints on a chip should be uniform. Voids in the bumps after reflow can occur during the reflow process in bumps with high ratio of bump diameter to bump height, i.e. low bumps with large diameter. No failures have been found to be related to these voids. Solder joint inspection after reflow can be done with X-ray to monitor defects such as bridging, open circuits and voids.

### 17.3.3 Rework

In general, rework is not recommended. By rework we mean the process of removing the chip from the substrate and replacing it with a new chip. If a chip is removed from the substrate, most solder balls of the chip will be damaged. In that case it is recommended not to re-use the chip again.

Device removal can be done when the substrate is heated until it is certain that all solder joints are molten. The chip can then be carefully removed from the substrate without damaging the tracks and solder lands on the substrate. Removing the device must be done using plastic tweezers, because metal tweezers can damage the silicon. The surface of the substrate should be carefully cleaned and all solder and flux residues and/or underfill removed. When a new chip is placed on the substrate, use the flux process instead of solder on the solder lands. Apply flux on the bumps at the chip side as well as on the solder pads on the substrate. Place and align the new chip while viewing with a microscope. To reflow the solder, use the solder profile shown in application note AN10365 "Surface mount reflow soldering description".

#### 17.3.4 Cleaning

Cleaning can be done after reflow soldering.

## 18. Abbreviations

Table 21. Abbreviations

Acronym	Description
ESD	ElectroStatic Discharge
CDM	Charged Device Model
HBM	Human Body Model
USB	Universal Serial Bus
VOIP	Voice over Internet Protocol

## 19. Revision history

Table 22. Revision history

Document ID	Release date	Data sheet status	Change notice	Supersedes
NX5P3090 v.1	20160801	Product data sheet	-	-

## 20. Legal information

### 20.1 Data sheet status

Document status <sup>[1][2]</sup>	Product status <sup>[3]</sup>	Definition
Objective [short] data sheet	Development	This document contains data from the objective specification for product development.
Preliminary [short] data sheet	Qualification	This document contains data from the preliminary specification.
Product [short] data sheet	Production	This document contains the product specification.

[1] Please consult the most recently issued document before initiating or completing a design.

[2] The term 'short data sheet' is explained in section "Definitions".

[3] The product status of device(s) described in this document may have changed since this document was published and may differ in case of multiple devices. The latest product status information is available on the Internet at URL <http://www.nxp.com>.

### 20.2 Definitions

**Draft** — The document is a draft version only. The content is still under internal review and subject to formal approval, which may result in modifications or additions. NXP Semiconductors does not give any representations or warranties as to the accuracy or completeness of information included herein and shall have no liability for the consequences of use of such information.

**Short data sheet** — A short data sheet is an extract from a full data sheet with the same product type number(s) and title. A short data sheet is intended for quick reference only and should not be relied upon to contain detailed and full information. For detailed and full information see the relevant full data sheet, which is available on request via the local NXP Semiconductors sales office. In case of any inconsistency or conflict with the short data sheet, the full data sheet shall prevail.

**Product specification** — The information and data provided in a Product data sheet shall define the specification of the product as agreed between NXP Semiconductors and its customer, unless NXP Semiconductors and customer have explicitly agreed otherwise in writing. In no event however, shall an agreement be valid in which the NXP Semiconductors product is deemed to offer functions and qualities beyond those described in the Product data sheet.

### 20.3 Disclaimers

**Limited warranty and liability** — Information in this document is believed to be accurate and reliable. However, NXP Semiconductors does not give any representations or warranties, expressed or implied, as to the accuracy or completeness of such information and shall have no liability for the consequences of use of such information. NXP Semiconductors takes no responsibility for the content in this document if provided by an information source outside of NXP Semiconductors.

In no event shall NXP Semiconductors be liable for any indirect, incidental, punitive, special or consequential damages (including - without limitation - lost profits, lost savings, business interruption, costs related to the removal or replacement of any products or rework charges) whether or not such damages are based on tort (including negligence), warranty, breach of contract or any other legal theory.

Notwithstanding any damages that customer might incur for any reason whatsoever, NXP Semiconductors' aggregate and cumulative liability towards customer for the products described herein shall be limited in accordance with the *Terms and conditions of commercial sale* of NXP Semiconductors.

**Right to make changes** — NXP Semiconductors reserves the right to make changes to information published in this document, including without limitation specifications and product descriptions, at any time and without notice. This document supersedes and replaces all information supplied prior to the publication hereof.

**Suitability for use** — NXP Semiconductors products are not designed, authorized or warranted to be suitable for use in life support, life-critical or safety-critical systems or equipment, nor in applications where failure or malfunction of an NXP Semiconductors product can reasonably be expected to result in personal injury, death or severe property or environmental damage. NXP Semiconductors and its suppliers accept no liability for inclusion and/or use of NXP Semiconductors products in such equipment or applications and therefore such inclusion and/or use is at the customer's own risk.

**Applications** — Applications that are described herein for any of these products are for illustrative purposes only. NXP Semiconductors makes no representation or warranty that such applications will be suitable for the specified use without further testing or modification.

Customers are responsible for the design and operation of their applications and products using NXP Semiconductors products, and NXP Semiconductors accepts no liability for any assistance with applications or customer product design. It is customer's sole responsibility to determine whether the NXP Semiconductors product is suitable and fit for the customer's applications and products planned, as well as for the planned application and use of customer's third party customer(s). Customers should provide appropriate design and operating safeguards to minimize the risks associated with their applications and products.

NXP Semiconductors does not accept any liability related to any default, damage, costs or problem which is based on any weakness or default in the customer's applications or products, or the application or use by customer's third party customer(s). Customer is responsible for doing all necessary testing for the customer's applications and products using NXP Semiconductors products in order to avoid a default of the applications and the products or of the application or use by customer's third party customer(s). NXP does not accept any liability in this respect.

**Limiting values** — Stress above one or more limiting values (as defined in the Absolute Maximum Ratings System of IEC 60134) will cause permanent damage to the device. Limiting values are stress ratings only and (proper) operation of the device at these or any other conditions above those given in the Recommended operating conditions section (if present) or the Characteristics sections of this document is not warranted. Constant or repeated exposure to limiting values will permanently and irreversibly affect the quality and reliability of the device.

**Terms and conditions of commercial sale** — NXP Semiconductors products are sold subject to the general terms and conditions of commercial sale, as published at <http://www.nxp.com/profile/terms>, unless otherwise agreed in a valid written individual agreement. In case an individual agreement is concluded only the terms and conditions of the respective agreement shall apply. NXP Semiconductors hereby expressly objects to applying the customer's general terms and conditions with regard to the purchase of NXP Semiconductors products by customer.

**No offer to sell or license** — Nothing in this document may be interpreted or construed as an offer to sell products that is open for acceptance or the grant, conveyance or implication of any license under any copyrights, patents or other industrial or intellectual property rights.

**Export control** — This document as well as the item(s) described herein may be subject to export control regulations. Export might require a prior authorization from competent authorities.

**Non-automotive qualified products** — Unless this data sheet expressly states that this specific NXP Semiconductors product is automotive qualified, the product is not suitable for automotive use. It is neither qualified nor tested in accordance with automotive testing or application requirements. NXP Semiconductors accepts no liability for inclusion and/or use of non-automotive qualified products in automotive equipment or applications.

In the event that customer uses the product for design-in and use in automotive applications to automotive specifications and standards, customer (a) shall use the product without NXP Semiconductors' warranty of the product for such automotive applications, use and specifications, and (b) whenever customer uses the product for automotive applications beyond

NXP Semiconductors' specifications such use shall be solely at customer's own risk, and (c) customer fully indemnifies NXP Semiconductors for any liability, damages or failed product claims resulting from customer design and use of the product for automotive applications beyond NXP Semiconductors' standard warranty and NXP Semiconductors' product specifications.

**Translations** — A non-English (translated) version of a document is for reference only. The English version shall prevail in case of any discrepancy between the translated and English versions.

## 20.4 Trademarks

Notice: All referenced brands, product names, service names and trademarks are the property of their respective owners.

## 21. Contact information

For more information, please visit: <http://www.nxp.com>

For sales office addresses, please send an email to: [salesaddresses@nxp.com](mailto:salesaddresses@nxp.com)

## 22. Contents

<b>1</b>	<b>General description</b> . . . . .	<b>1</b>	17.3	Reflow soldering	26
<b>2</b>	<b>Features and benefits</b> . . . . .	<b>1</b>	17.3.1	Stand off	27
<b>3</b>	<b>Applications</b> . . . . .	<b>2</b>	17.3.2	Quality of solder joint	27
<b>4</b>	<b>Ordering information</b> . . . . .	<b>2</b>	17.3.3	Rework	27
4.1	Ordering options	2	17.3.4	Cleaning	28
<b>5</b>	<b>Marking</b> . . . . .	<b>2</b>	<b>18</b>	<b>Abbreviations</b>	<b>29</b>
<b>6</b>	<b>Functional diagram</b> . . . . .	<b>3</b>	<b>19</b>	<b>Revision history</b>	<b>30</b>
<b>7</b>	<b>Pinning information</b> . . . . .	<b>4</b>	<b>20</b>	<b>Legal information</b>	<b>31</b>
7.1	Pinning	4	20.1	Data sheet status	31
7.2	Pin description	4	20.2	Definitions	31
<b>8</b>	<b>Functional description</b> . . . . .	<b>5</b>	20.3	Disclaimers	31
8.1	EN Input	5	20.4	Trademarks	32
8.2	Under-voltage lock-out	5	<b>21</b>	<b>Contact information</b>	<b>32</b>
8.3	ILIM	5	<b>22</b>	<b>Contents</b>	<b>33</b>
8.4	Over-current protection (OCP)	5			
8.4.1	Over-current at start-up	5			
8.4.2	Over-current when enabled	6			
8.4.3	Short circuit when enabled	6			
8.5	Reverse-Current protection (RCP)	6			
8.6	FAULT output	6			
8.7	Over-temperature protection	6			
<b>9</b>	<b>Application diagram</b> . . . . .	<b>7</b>			
<b>10</b>	<b>Limiting values</b> . . . . .	<b>8</b>			
<b>11</b>	<b>Recommended operating conditions</b> . . . . .	<b>8</b>			
<b>12</b>	<b>Thermal characteristics</b> . . . . .	<b>9</b>			
<b>13</b>	<b>Static characteristics</b> . . . . .	<b>9</b>			
13.1	Graphs	10			
13.2	Thermal shutdown	12			
13.3	ON resistance	13			
13.4	ON resistance graphs	13			
13.5	Current limit	14			
13.6	Current limit graphs	14			
<b>14</b>	<b>Dynamic characteristics</b> . . . . .	<b>15</b>			
14.1	Waveform and test circuits	15			
<b>15</b>	<b>Package outline</b> . . . . .	<b>21</b>			
<b>16</b>	<b>Packing information</b> . . . . .	<b>22</b>			
16.1	Packing method	22			
16.2	Product orientation	23			
16.3	Carrier tape dimensions	23			
16.4	Reel dimensions	24			
16.5	Barcode label	25			
<b>17</b>	<b>Soldering of WLCSP packages</b> . . . . .	<b>26</b>			
17.1	Introduction to soldering WLCSP packages	26			
17.2	Board mounting	26			

Please be aware that important notices concerning this document and the product(s) described herein, have been included in section 'Legal information'.

© NXP Semiconductors N.V. 2016.

All rights reserved.

For more information, please visit: <http://www.nxp.com>

For sales office addresses, please send an email to: [salesaddresses@nxp.com](mailto:salesaddresses@nxp.com)

Date of release: 1 August 2016

Document identifier: NX5P3090

## Looking for pricing, stock, or lifecycle information?

Click below to explore more details on WIN SOURCE:

- ⊖ [View NX5P3090UKZ on WIN SOURCE](#)
- ⊖ [NXP / Nexperia Information](#)

## Optimize Your Supply Chain with WIN SOURCE Solutions

- ✓ Global Sourcing Solution
- ✓ Obsolete Management
- ✓ Cost Control Management
- ✓ Shortage Management
- ✓ Alternative Solution
- ✓ Excess Inventory Management