



**THE DATASHEET OF
GL100MD1MP1**



SHARP

OPTO-ELECTRONIC DEVICES DIVISION
ELECTRONIC COMPONENTS GROUP
SHARP CORPORATION

SPECIFICATION

DEVICE SPECIFICATION FOR

INFRARED EMITTING DIODE

MODEL No.

GL100MD1MP1

Specified for

Olivetti

Enclosed please find copies of the Specifications which consists of 14 pages including cover.
After confirmation of the contents, please be sure to send back copy of the Specifications
with approving signature on each.

CUSTOMER'S APPROVAL

DATE

BY

PRESENTED

DATE

June 22, 2002

BY

H. Ogura

H. Ogura,
Department General Manager of
Engineering Dept., III
Opto-Electronic Devices Div.
ELECOM Group
SHARP CORPORATION

Product name : INFRARED EMITTING DIODE

Model No. : GL100MD1MP1

1. These specification sheets include materials protected under copyright of Sharp Corporation ("Sharp"). Please do not reproduce or cause anyone to reproduce them without Sharp's consent.
2. When using this product, please observe the absolute maximum ratings and the instructions for use outlined in these specification sheets, as well as the precautions mentioned below. Sharp assumes no responsibility for any damage resulting from use of the product which does not comply with the absolute maximum ratings and the instructions included in these specification sheets, and the precautions mentioned below.

(Precautions)

- (1) This product is designed for use in the following application areas ;

[· OA equipment · Audio visual equipment · Home appliances
· Telecommunication equipment (Terminal) · Measuring equipment
· Tooling machines · Computers]

If the use of the product in the above application areas is for equipment listed in paragraphs (2) or (3), please be sure to observe the precautions given in those respective paragraphs.

- (2) Appropriate measures, such as fail-safe design and redundant design considering the safety design of the overall system and equipment, should be taken to ensure reliability and safety when this product is used for equipment which demands high reliability and safety in function and precision, such as ;

[· Transportation control and safety equipment (aircraft, train, automobile etc.)
· Traffic signals · Gas leakage sensor breakers · Rescue and security equipment
· Other safety equipment]

- (3) Please do not use this product for equipment which require extremely high reliability and safety in function and precision, such as ;

[· Space equipment · Telecommunication equipment (for trunk lines)
· Nuclear power control equipment · Medical equipment]

- (4) Please contact and consult with a Sharp sales representative if there are any questions regarding interpretation of the above three paragraphs.

3. Please contact and consult with a Sharp sales representative for any questions about this product.

1. Application
This specification applies to the outline and characteristics of GaAlAs type chip infrared emitting diode Model No. GL100MD1MP1.
2. Outline
Refer to the attached drawing No. CY11151i02, page 3.
3. Ratings and characteristics
Refer to the attached sheet, page 4, 5.
4. Reliability
Refer to the attached sheet, page 6.
5. Outgoing inspection
Refer to the attached sheet, page 7.
6. Supplement
 - 6-1 Packing specifications
Refer to the attachment-2-1 to 2-4.
 - 6-2 This product shall not contain the following materials.
Also, the following materials shall not be used in the production process for this product.
Materials for ODS : CFCs, Halon, Carbon tetrachloride, 1.1.1-Trichloroethane (Methylchloroform)
 - 6-3 Product mass (Piece) : Approximately 10mg
 - 6-4 Optical diffusion medicine added resin is used for the resin package of this product.
Optical transmittance rate (940m) : 65 to 75%
7. Notes
 - 7-1 In circuit designing, make allowance for the degradation of the light emitting diode output that results from long continuous operation. (50% degradation/ 5years)
 - 7-2 Soldering
 - (1) Solder reflow
Please do only one soldering at the temperature and the time within the temperature profile in attachment-1-1, 1.
 - (2) Soldering by hand
To solder onto lead pins, please solder at 260°C for 3 seconds or less. Please be careful not to give the mechanical stress to the package when soldering because it may cause the deformation or defect due to the plated connection.
 - (3) Case of other soldering
Other soldering methods such as dip soldering and VPS shall not be used. Please use (1) and (2).

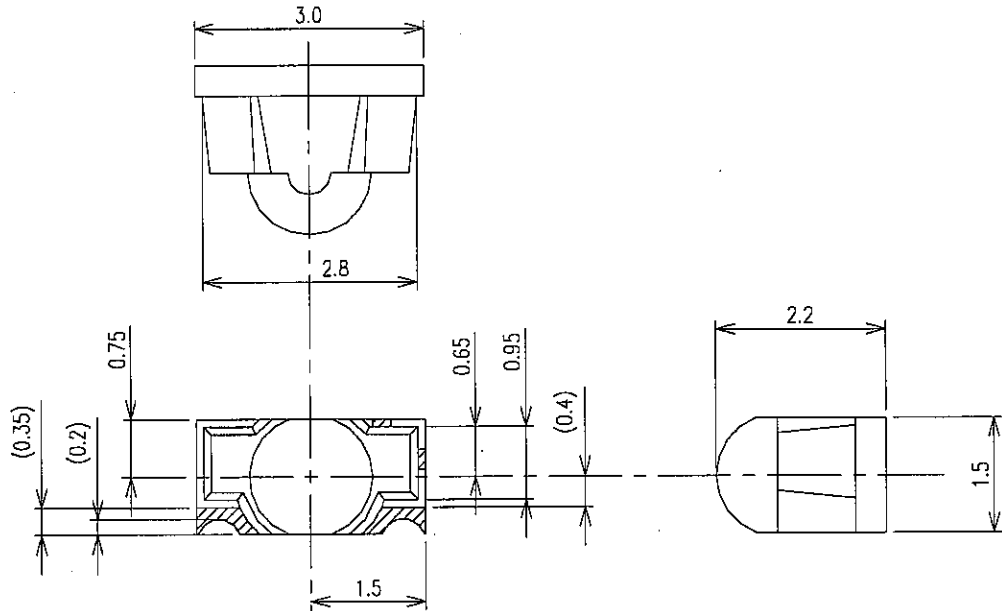

The pattern example from the view point of PCB (Side view)

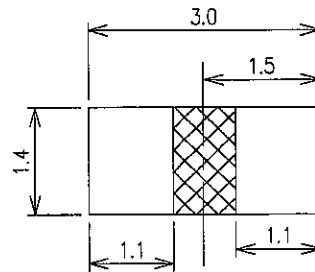
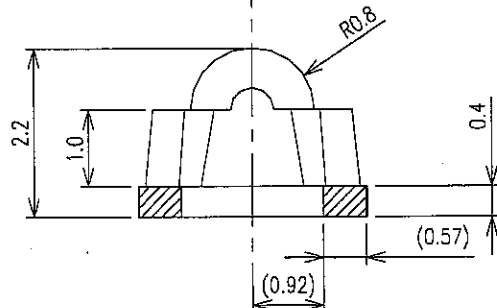

The pattern example from the view point of PCB (Top view)

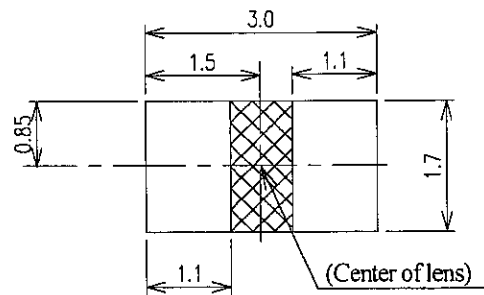
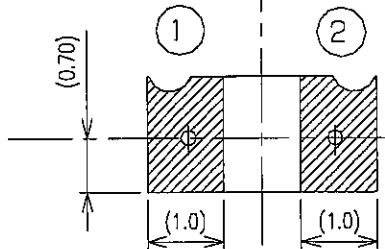

⊠: Please be careful not to put a pattern on the shaded portion.

- 1) Unspecified tolerance shall be ± 0.2
- 2) Dimensions in parenthesis are shown for reference.
- 3) ⊠ area : Au plating
- 4) Resin burr shall not be included in outline dimensions.
- 5) Package : Translucent red

Pin name Pin arrangement

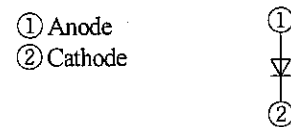

Scale	Material	Finish	Name	GL100MD1MP1 Outline Dimensions
10 / 1				
Unit	Package : Epoxy resin	Pin : Au plating	Drawing No.	CY11151i02
1=1 / 1 mm				

3. Ratings and characteristics

3.1 Absolute maximum ratings Ta=25°C

Parameter	Symbol	Rating	Unit
Forward current	I_F	50	mA
Peak forward current *1	I_{FM}	0.5	A
Reverse voltage	V_R	6	V
Power dissipation	P	75	mW
Operating temperature	Topr	-30 to +85	°C
Storage temperature	Tstg	-40 to +95	°C
Soldering temperature *2	Tsol	240	°C

*1 Pulse width : 100 μ s, Duty ratio : 0.01

*2 Within 10sec (MAX.) according to the attached reflow profile.

3.2 Electro-optical characteristics Ta=25°C

Parameter	Symbol	Conditions	MIN.	TYP.	MAX.	Unit
Forward voltage	V_F	$I_F=20\text{mA}$	-	1.2	1.5	V
Peak forward voltage	V_{FM}	$I_{FM}=0.5\text{A}$	-	3.0	4.0	V
Reverse current	I_R	$V_R=3\text{V}$	-	-	10	μ A
Radiant flux	ϕ_e	$I_F=20\text{mA}$	2.0	-	6.0	mW
Radiant intensity	I_E	$I_F=20\text{mA}$	(0.3)	0.95	(1.8)	mW/sr
Peak emission wavelength	λ_p	$I_F=5\text{mA}$	-	940	-	nm
Spectrum radiation bandwidth	$\Delta \lambda$	$I_F=5\text{mA}$	-	45	-	nm
Terminal capacitance	Ct	$V_R=0, f=1\text{MHz}$	-	50	-	pF
Cut-off frequency	fc	-	-	300	-	kHz
Half intensity angle	$\Delta \theta$	-	-	± 80	-	°

() : Reference value

(3.3) Forward current vs. ambient temperature

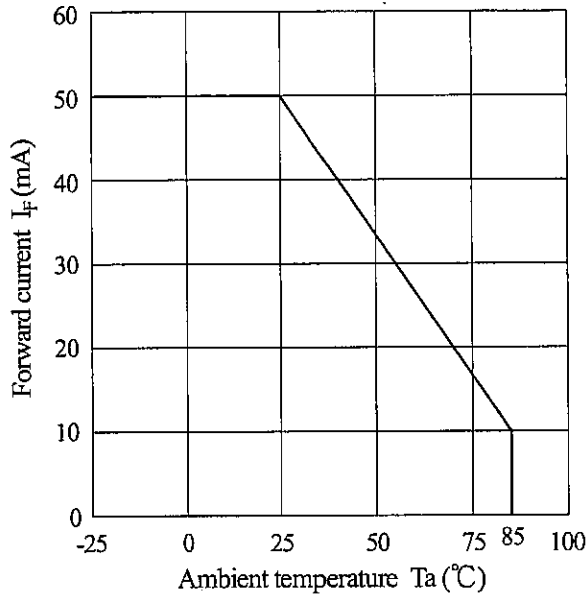

(3.4) Peak forward current vs. duty ratio
 Pulse width $\leq 100 \mu s$
 $T_a = 25^\circ C$

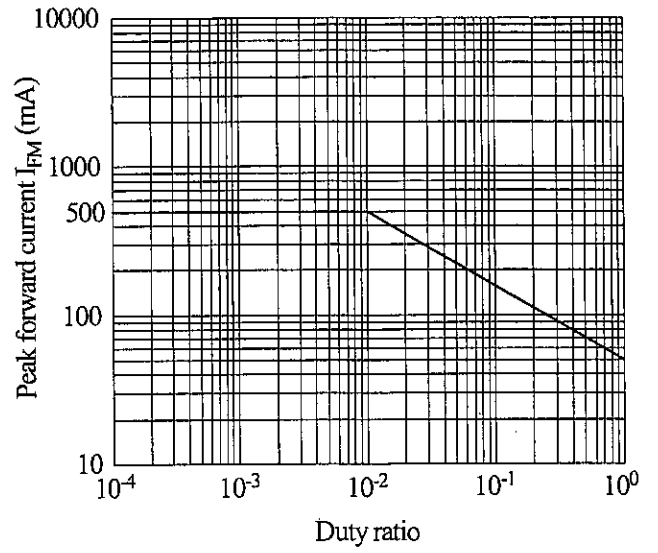

(3.5) Radiation diagram (For reference)
 $T_a = 25^\circ C$

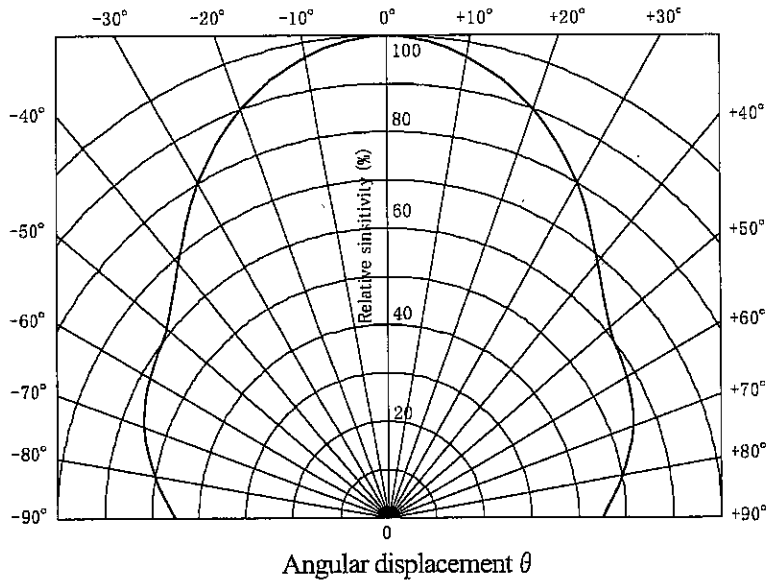

4. Reliability

The reliability of products shall satisfy items listed below.

Confidence level : 90%
LTPD : 10 or 20

Test Items	Test Conditions	Failure Judgement Criteria	Samples (n)
			Defective(C)
Temperature cycling	1 cycle -40°C ← → +95°C (30min) (30min) 20 cycles test	$\phi_e < L \times 0.8$ $\phi_e > U \times 1.2$ $I_R > U \times 2.0$ $V_F > U \times 1.2$ U: Upper specification limit L: Lower specification limit	n=22, C=0
High temp. and high humidity storage	+60°C, 90%RH, 500h		n=22, C=0
High temp. storage	+95°C, 500h		n=22, C=0
Low temp. storage	-40°C, 500h		n=22, C=0
Operation life	+25°C, I _F =50mA, 500h		n=22, C=0
Mechanical shock	1000m/s ² , 6ms, Half sine wave 3 times/±X, ±Y, ±Z direction		n=11, C=0
Variable frequency vibration	200m/s ² 100 to 2000 to 100Hz /For approx. 4min 48 min/X, Y, Z direction		n=11, C=0
Soldering heat	240±5°C, 10±0.5s The temperature profile is according to the precautions for soldering (attachment-1)		n=11, C=0

5. Outgoing inspection

(1) Inspection lot

Inspection shall be carried out per each delivery lot.

(2) Inspection method

A single sampling plan, normal inspection level II based on ISO2859 shall be adopted.

Parameter	Inspection items and test method				AQL(%)	
Major defect	1	Disconnection, short			0.065	
	2	Inverse polarity on terminal				
	3	Soldering defect (Obstacle to use)				
	4	Characteristics defect				
		Parameter	Symbol	Judgement criteria MIN. MAX.		Unit
		Forward voltage	V_F	- 1.5		V
	Reverse current	I_R	- 10	μA		
	Radian flux	ϕ_e	2.0 6.0	mW		
	Test conditions refer to parameter 3.2.					
Minor defect	1	Appearance defect			0.25	
		Parameter	Judgement criteria			
		Crack	Visible crack irrespective of its position shall be defect.			
		Split, Chip, Scratch, Stain, Blur	One which affects the characteristics of parameter 3.2 shall be defect.			
	Bubble, Foreign matter (One on resin surface which can wipe off shall not be applied.)	1. On light emitter One which affects the characteristics of parameter 3.2 shall be defect. 2. Area excepting on light emitter 1.0mm ϕ or more shall be defect.				

Precautions for Soldering GL100MD1MP1

1. In case, solder reflow

Please do only one soldering at the temperature and the time within the temperature profile as shown in the figure below.

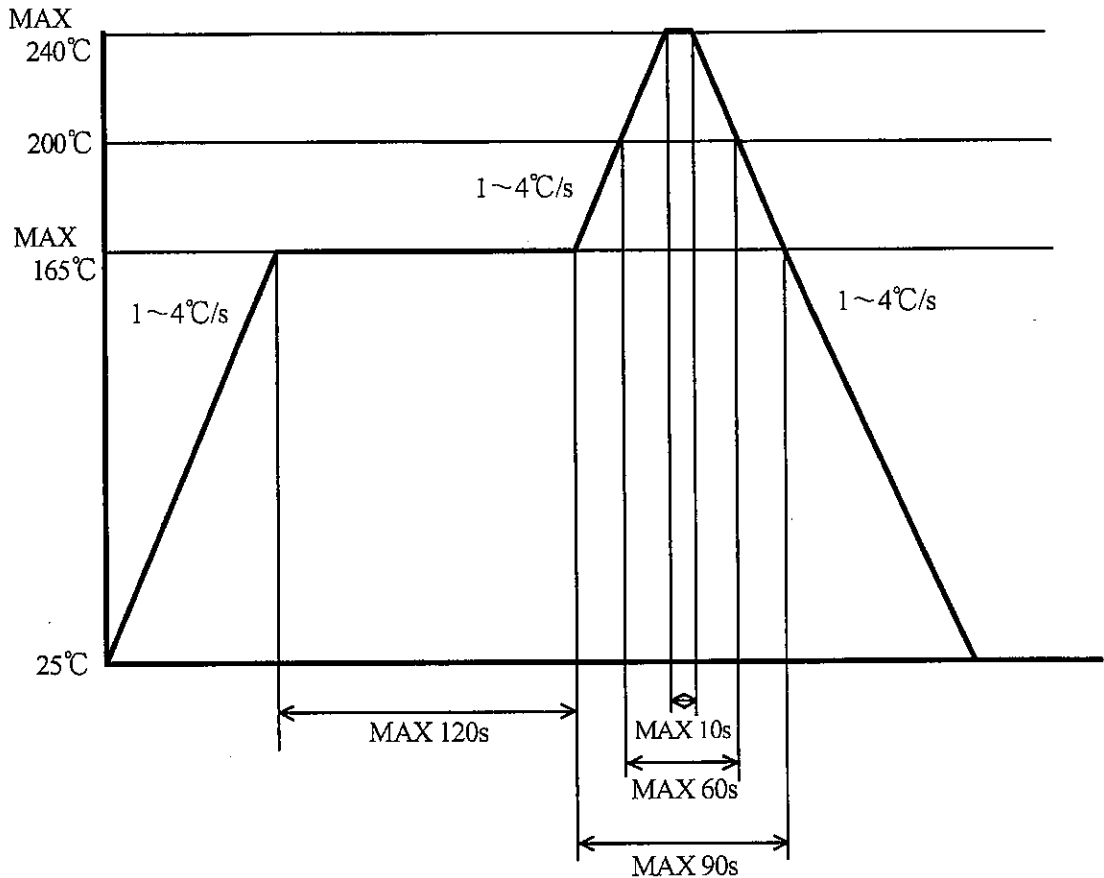

2. Other precautions

An infrared lamp used to heat up for soldering may cause a localized temperature rise in the resin.

So keep the package temperature within that specified in Item 1.

This device has pin structure connected and soldered on the epoxy resin package. Please be acknowledged that mechanical stress must not be put on the package when you solder the device by hand because there is possibility of deformation or defect of the device.

Even if within the temperature profile above, there is the possibility that the gold wire in package is broken in case that the deformation of PCB gives the affection to lead pins. Please use after confirmation the conditions fully by actual solder reflow machine.

3. Storage and management after open

3.1 Storage condition : Storage shall be in accordance with the below conditions.

Storage temp. : 5 to 30°C

Storage humidity : 70%RH or less

3.2 Treatment after open

- (1) After open, please mount at the conditions of humidity 60%RH or less and temperature 5 to 25°C within 2 days.
- (2) In case that long term storage is needed, devices should either be stored in dry box, or re-sealed to moist-proof bag with siccative and leave them in the environment where the temperature is 5 to 30°C, at the humidity condition of below 70%RH. Devices must be mounted within 2 weeks.

3.3 Baking before mounting

In case that it could not carry out the above treatment, it is able to mount by baking treatment.

However baking treatment shall be limited only 1 time.

Recommended conditions : 125°C, 16 to 24 hours

- ※ Baking treatment can not carry out at the packaged condition. Please carry out baking at the condition of mounting on PCB or getting on the metal tray.

Packing specifications (ϕ 180mm reel)

1. Application

This specification applies to the taping specifications and the relation items for the GL100MD1MP1.

2. Taping method

(2.1) Tape structure and Dimensions (Refer to the attachment-2-2)

The tape shall have a structure in which a cover tape is sealed heat-pressed on the carrier tape made by PS.

(2.2) Reel structure and Dimensions (Refer to the attachment-2-3)

The taping reel shall be of plastic (PS material) with its dimensions as shown in the attached drawing.

(2.3) Direction of product insertion (Refer to the attachment-2-3)

Product direction in carrier tape shall direct to the through hole electrode side at the tape pull-out direction, and direct the lens side at the cover tape side.

3. Adhesiveness of cover tape

The exhalation force between carrier tape and cover tape shall be 0.2N to 1.0N for the angle from 160° to 180° .

4. Rolling method and quantity

Wind the tape back on the reel so that the cover tape will be outside the tape.

Attach more than 20cm of blank tape to the trailer and the leader of the tape and fix the both ends with adhesive tape.

One reel shall contain 1500pcs.

5. Marking

The outer packaging case shall be marked with following information.

* Model No. * Number of pieces delivered * Production date

6. Safety protection during shipping

There shall be no deformation of component or degradation of electrical characteristics due to shipping.

Tape structure and Dimensions

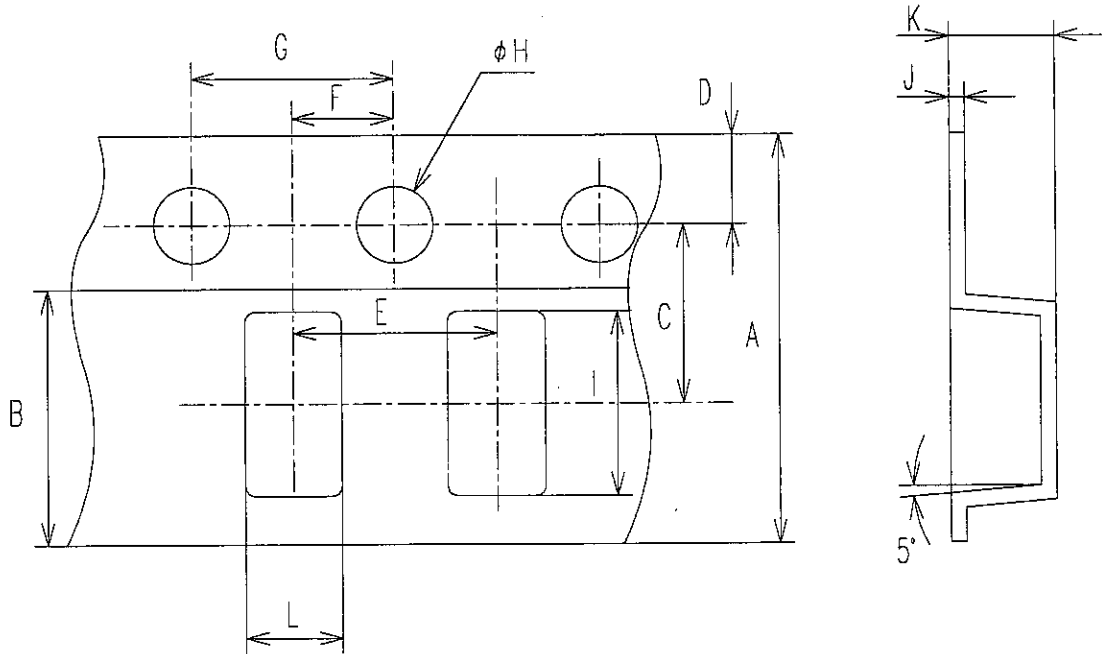

Symbol Unit	Cheek letter						
	A	B	C	D	E	F	G
mm	8.0±0.3	5.5±0.1	35±0.05	1.75±0.1	4.0±0.1	2.0±0.05	4.0±0.1

Symbol Unit	Cheek letter				
	H	I	J	K	L
mm	$\phi 1.5^{+0.1}_0$	3.3±0.1	0.3±0.05	2.45±0.1	1.8±0.1

Reel structure and Dimensions

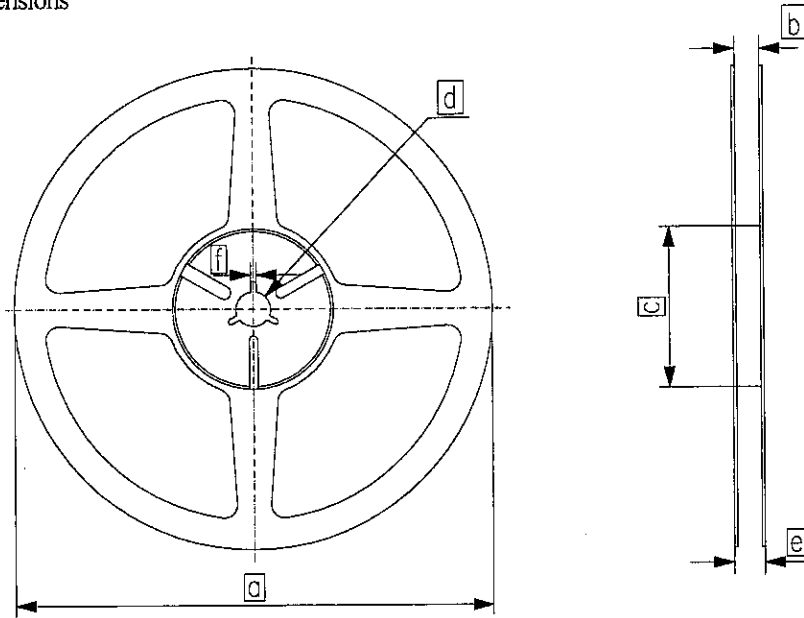

Symbol Unit	Check letter					
	a	b	c	d	e	f
mm	180	$9^{+0.3}_{-0}$	60^{+1}_{-0}	13 ± 0.2	11.4 ± 1	2.0 ± 0.5

Direction of product insertion

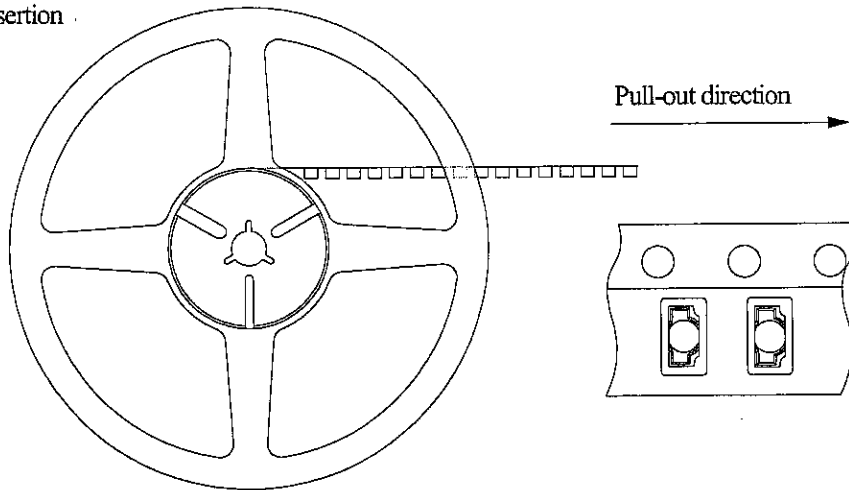

Moisture-proof package specification (φ 180mm reel)

1. Application

This specification applies to the products which Sharp delivers to customer.

2. Packing specifications

2.1 Packaging material

Name	Material	Q'ty	Aim
Aluminum laminated bag	Aluminum polyethylene	Refer to 2.2	Moisture-proof
Label	Paper(-made)	-	Indication of Model No. and Q'ty
Humidity indicator card	Paper(-made)	1 sheet / reel	Indication of Humidity

2.2 Packaging method

- (1) Seal the aluminum laminated bag included the ruled tape-reel and humidity indicator card quantity.
- (2) Fill up the blank of label and paste on the bag.
- (3) Put the moisture-proof laminated bag in the ruled case

Package shape	Product	Q'ty	Moisture-proof sack Q'ty
Tape-reel (φ 180mm)	1ch. type	1500pcs. / reel	1 reel / bag

Minimum order Q'ty : 1 reel / bag

3. Storage and management after open

3.1 Storage condition : Storage shall be in accordance with the below conditions.

Storage temp. : 5 to 30°C

Storage humidity : 70%RH or less

3.2 Treatment after open

- (1) After open, please mount at the conditions of humidity 60%RH or less and temperature 5 to 25°C within 2 days.
- (2) In case of long time storage after open, please mount at the conditions of humidity 70%RH or less and temperature 5 to 30°C within 2 weeks by using dry box or resealing with desiccant in moisture-proof sack by sealer.

3.3 Baking before mounting

In case that it could not carry out the above treatment, it is able to mount by baking treatment. However baking treatment shall be limited only 1 time.

Recommended conditions : 125°C, 16 to 24 hours

※ Baking treatment can not carry out at the packaged condition. Please carry out baking at the condition of mounting on PCB or getting on the metal tray.

Looking for pricing, stock, or lifecycle information?

Click below to explore more details on WIN SOURCE:

- ⊖ [View GL100MD1MP1 on WIN SOURCE](#)
- ⊖ [Sharp Microelectronics Information](#)

Optimize Your Supply Chain with WIN SOURCE Solutions

- ✓ Global Sourcing Solution
- ✓ Obsolete Management
- ✓ Cost Control Management
- ✓ Shortage Management
- ✓ Alternative Solution
- ✓ Excess Inventory Management