



THE DATASHEET OF LAUNCHXL-F28379D



LAUNCHXL-F28379D Overview

The C2000™ LAUNCHXL-F28379D LaunchPad™ is a complete low-cost development board for the Texas Instruments Delfino™ F2837xD devices. The LAUNCHXL-F28379D kit features all the hardware and software necessary to develop applications based on the F2837xD microcontrollers. This LaunchPad is based on the superset F28379D device, and easily allows users to migrate to lower feature set and/or lower pin count F2837x devices once the design needs are known. It offers an on-board JTAG debug tool allowing direct interface to a PC for easy programming, debugging, and evaluation. In addition to JTAG emulation, the USB interface provides a UART serial connection from the F28379D device to the host PC.

Contents

| | | |
|---|---|----|
| 1 | Introduction | 2 |
| 2 | Kit Contents..... | 3 |
| 3 | Installation | 4 |
| 4 | Getting Started With the LAUNCHXL-F28379D | 5 |
| 5 | Hardware Configuration..... | 5 |
| 6 | LAUNCHXL-F28379D Hardware | 8 |
| 7 | References | 26 |
| 8 | Frequently Asked Questions (FAQ)..... | 27 |

List of Figures

| | | |
|----|---------------------------------------|----|
| 1 | LAUNCHXL-F28379D Board Overview | 3 |
| 2 | P01_Block Diagram | 10 |
| 3 | P02_XDS100v2..... | 11 |
| 4 | P03_Power | 12 |
| 5 | P04_ADCIND | 13 |
| 6 | P05_PWM-DAC | 13 |
| 7 | P06_BoosterPack Headers | 14 |
| 8 | P07_F28379D-PWR | 14 |
| 9 | P08_F28379D-IO1 | 15 |
| 10 | P09_F28379_IO2 | 16 |
| 11 | P10_EX-Headers | 17 |
| 12 | Top | 18 |
| 13 | GND | 18 |
| 14 | Route1 | 18 |
| 15 | Route2 | 18 |
| 16 | VDD | 18 |
| 17 | Bottom | 18 |
| 18 | Top Silkscreen Overlay..... | 18 |
| 19 | Bottom Silkscreen Overlay | 18 |
| 20 | Top Pad Master | 19 |
| 21 | Bottom Pad Master | 19 |
| 22 | | 28 |

List of Tables

| | | |
|---|--|----|
| 1 | Supplying the LaunchPad With 3.3 V | 6 |
| 2 | Supplying the LaunchPad With 5 V | 6 |
| 3 | Positions of Signals Present on Switch S1 | 7 |
| 4 | Revision 2.0: Resistor Selection for Routing Dual-Mapped Signals | 7 |
| 5 | F28379D LaunchPad Pin Out and Pin Mux Options - J1, J3 | 8 |
| 6 | F28379D LaunchPad Pin Out and Pin Mux Options - J4, J2 | 8 |
| 7 | F28379D LaunchPad Pin Out and Pin Mux Options - J5, J7 | 9 |
| 8 | F28379D LaunchPad Pin Out and Pin Mux Options - J8, J6 | 9 |
| 9 | LAUNCHXL-F28379D Bill of Materials | 20 |

Trademarks

C2000, LaunchPad, Delfino, Code Composer Studio are trademarks of Texas Instruments. Windows is a registered trademark of Microsoft Corporation in the United States and/or other countries. All other trademarks are the property of their respective owners.

1 Introduction

Users can download an unrestricted copy of the latest version of Code Composer Studio™ IDE to write, download, and debug applications on the LAUNCHXL-F28379D board. The debugger is unobtrusive, allowing the user to run an application at full speed with hardware breakpoints and available single step execution while consuming no extra hardware resources.

As shown in [Figure 1](#), the LAUNCHXL-F28379D LaunchPad features include:

- USB debugging and programming interface via a high-speed galvanically isolated XDS100v2 debug probe featuring a USB/UART connection
- Superset TMS320F28379D device
- Two user LEDs
- Device reset pushbutton
- Easily accessible device pins for debugging purposes or as sockets for adding customized extension boards
- Dual 5 V quadrature encoder interfaces
- CAN Interface with integrated transceiver
- Boot selection switches
- Differential Amplifier to provide buffered signals to ADCD for 16-bit mode
- Optional SMA connection points P/N:SMA-J-P-H-ST-EM1
- Four Sigma Delta demodulator inputs brought to the BP headers

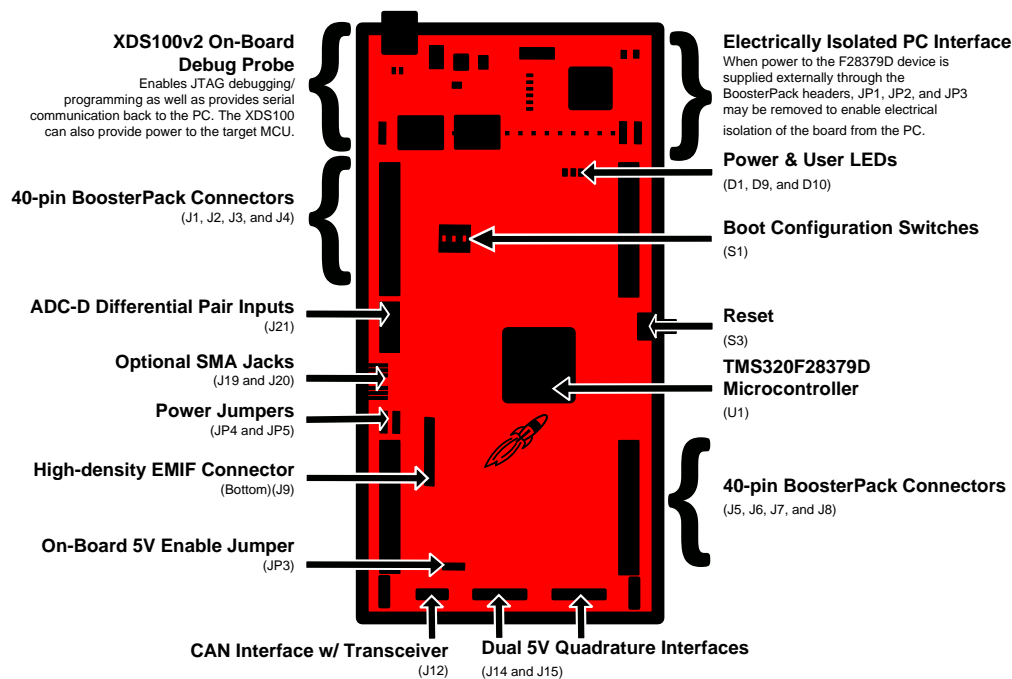

Figure 1. LAUNCHXL-F28379D Board Overview

2 Kit Contents

The LAUNCHXL-F28379D LaunchPad kit includes the following items:

- C2000 Delfino LaunchPad Board (LAUNCHXL-F28379D)
- Mini USB-B Cable, 0.5m
- Quick Start Guide

2.1 Revisions

The first production revision of the LAUNCHXL-F28379D in 2016 was Revision 1.1. In late 2017 the LAUNCHXL-F28379D revision changed from 1.1 to 2.0 to fix various issues and make improvements to the design.

All Revisions:

- Resistor R7 in the oscillator circuit is incorrectly placed or should not be installed. This resistor may impact startup time or robustness of the clocking circuit over the full operating range of the MCU or different physical layouts of this circuit. The probability is low that this resistor will have any impact on the functionality of this EVM as is not intended to be operated outside of Standard Temperature and Pressure in a lab or prototype environment. Do not use this circuit as reference. Follow the requirements for the Oscillator schematic as documented in the MCU Datasheet.
- The SCIA pins routed to the XDS100 v2 are not valid SCI boot mode pins. In addition, the other bootable SCI pins are not routed to any external connector. In other words, this LaunchPad is not capable of using the Boot to SCI boot mode. The [TMDSCNCD28379D](#) can be used to evaluate this feature.

Revision 1.1:

- ADCINA2 is shorted to VREFHIB. It is recommended that users avoid using the ADCINA2 channel.
- The VIN+ signal of component U1 may be shorted to ADCINB4 and/or ADCINC4 due to variance in manufacturing tolerances. No issues have been reported, but the clearances violate manufacturing rules and a short may occur.
- The silkscreen for the ADC channels on J3 and J7 are mixed up and some may be incorrect. Reference the schematic for the proper pin positions.

- J3 and J7 connectors are labeled incorrectly on the backside silkscreen. Refer the Rev 1.1 schematic for the proper signal locations on the connector

Revision 2.0:

A revision was made to resolve the layout issues present on revisions 1.1. In addition to the fixes for aforementioned issues, additional changes were made to the schematic and layout to improve available features and increase usability.

- User LEDs and current limiting resistor values were changed to prevent the LEDs from being too bright to look at directly.
- The CAN signal header J12 was shifted towards the center of the board and the silkscreen properly aligned. PGND was removed and replaced with GND for the proper grounding of the CAN signals.
- J11 and J13 were removed and replaced with a 0 Ω resistor selection tree for routing between the BoosterPack headers and the backside high-density connector J9. For more information on how to configure these resistors for the desired routing, see [Section 5.5](#).
- Additional EMIF1 signals were routed to J9 to enable SDRAM support. These signals are also routed to the BoosterPack headers. As such, these signals have a resistor selection network for routing the signals to either the BoosterPack headers, J9 or both. For the information on how to configure these resistors for the desired routing, see [Section 5.5](#).
- An additional jumper, J16, was added to the lower left corner of the board for an additional connection point for supplying +5 V externally.
- ADC input signal conditioning circuit was updated for proper operation under additional operating conditions. C4 is now 180 pF; R60/R61 are changed to 10k- Ω and are placed between the VOUT signal of U13 to the V_{OCM} of U1.
- Backside silkscreen for J3 and J7 have been corrected and reflect the proper signals at the noted location on the connector.

3 Installation

The F28379D LaunchPad is supported in Code Composer Studio.

3.1 Code Composer Studio

3.1.1 Download the Required Software

Code Composer Studio IDE is available for free without any restriction when used with the XDS100v2 debug probe on the C2000 LaunchPad. The software can be downloaded from the C2000 LaunchPad page at ti.com/launchpad. At this site, you can also download a copy of c2000Ware that includes drivers, examples, and other support software needed to get started.

3.1.2 Install the Software

Once downloaded, install Code Composer Studio and the C2000Ware package.

3.1.3 Install the Hardware

After Code Composer Studio is installed, plug the supplied USB cable into the C2000 LaunchPad board and into an available USB port on your computer.

Windows® will automatically detect the hardware and ask you to install software drivers. Let Windows run a search for the drivers and automatically install them. After Windows successfully installs the drivers for the integrated XDS100v2 debug probe, your LaunchPad is now ready for use.

4 Getting Started With the LAUNCHXL-F28379D

4.1 Getting Started

The first time the LAUNCHXL-F28379D board is powered-on a demo application will automatically start. Connect the LAUNCHXL-F28379D to a free USB port using the included mini-USB cable. The demo application will start with LEDs D9 and D10 blinking to show the device is active. If your board does not start the demo application, try setting switch S1 in the following positions and resetting the board: 1-UP, 2-UP, 3-DOWN.

4.2 Demo Application, ADC Sampling

The LAUNCHXL-F28379D includes a pre-programmed TMS320F28379D device. When the LaunchPad is powered via USB, the demo starts with an LED blink sequence. After a few seconds the device switches into an ADC sample mode.

Every 1 second the ADC samples pin ADCIN14 and the sampled data is represented as follows: If the sample is above mid-scale (2048), the blue LED D10 will illuminate. If the sample is below mid-scale, the red LED D9 will illuminate.

In addition to the LED indicators, ADC sample information is also displayed on your PC through the USB/UART connection. To view the UART information on your PC, first determine the COM port associated with the LaunchPad. To do this in Windows, right click on *My Computer* and click on *Properties*. In the dialog box that appears, click on the Hardware tab and open *Device Manager*. Look for an entry under Ports (COM & LPT) titled "USB Serial Port (COMX)", where X is a number. Remember this number for when you open a serial terminal. The demo applications UART data was written and debugged using PuTTY, and for the best user experience we recommend you use PuTTY to view the UART data. PuTTY can be downloaded from the following URL:

<http://www.chiark.greenend.org.uk/~sgtatham/putty/download.html>

Open your serial terminal program and open the COM port you found previously in device manager with the following settings: 115200 Baud, 8 data bits, no parity, 1 stop bit. After opening the serial port in your serial terminal, reset the LaunchPad with the reset push button S3 and observe the serial terminal to see the TI logo in ASCII art.

4.3 Program and Debug the ADC Sample Demo Application

The project and associated source code for the C2000 Delfino LaunchPad demo is included in the C2000Ware software package and should automatically be found by the TI Resource Explorer in Code Composer Studio. In the resource explorer, navigate C2000Ware to find the *device_support\F2837x\examples* folder. Expand this item and LAUNCHXL-F28379D, then select the LaunchPad Demo Application. Follow the steps in the main pane of the resource explorer to import, build, debug, and run this application.

4.4 Using Other C2000Ware Examples

Including the LaunchPad demo example described above, C2000Ware provides many examples demonstrating a majority of the features of the F2837x MCU. Most examples are configured by default to use the TMDSCNDC28379D ControlCARD, which has a different on-board clocking circuit. As such, some examples may not work as intended without minor modification. To make this easier on the designer, compiler switch has been added to automatically pick the proper clock configuration based on adding "_LAUNCHXL_F28379D" as a predefined symbol in the project properties. Refer to [Section 8](#) for more information on how and where to define this symbol.

5 Hardware Configuration

The F28379D LaunchPad provides users with several options for configuring the board.

5.1 ADC Resolution

The F28379D has 4 independent 16-bit/12-bit ADCs. The resolution of each ADC is SW selectable. ADCA, ADCB, and ADCC are all routed to the BoosterPack headers for use with different booster packs. Most BoosterPacks will use the ADC in 12-bit mode which supports Single Ended (SE) inputs. ADCD has been routed to a special side connector with ability to drive through a differential amplifier to support 16-bit mode with Differential Ended (DE) inputs.

5.2 Power Domain

The LaunchPad has several different power domains to enable JTAG Isolation. Jumpers JP1, JP2, JP3 control JTAG Isolation, supply GND, 3.3 V and 5 V to the rest of the board. There are also other jumpers that provide different methods for powering the device.

[Table 1](#) describes the different methods by which 3.3 V can be supplied to the device. It can be derived from USB in configuration 1. Here, the on-board regulator steps the 5 V from the USB port down to 3.3 V to be used by the XDS100v2 debug probe as well as connected to the device side of the LaunchPad through JP1. Configuration 1 is a non-isolated configuration. Alternately, in configuration 2 the debugger and USB connection are isolated from the device. The 3.3 V source must be provided externally through the BoosterPack headers or through J10.

Table 1. Supplying the LaunchPad With 3.3 V

| Configuration | JP1 | JP2 | USB | External 3.3 V | JTAG/USB Isolation Status |
|---------------|-----|-----|------------|----------------|---------------------------|
| 1 | Yes | Yes | Yes | No | Not Isolated |
| 2 | No | No | Don't Care | Yes | Isolated |

The LaunchPad also has a 5 V power rail. It can be supplied directly from the USB (not isolated) generated from a 3.3 V to 5 V step-up regulator through JP6, or supplied externally through the BoosterPack Headers or J16. [Table 2](#) describes these various configurations.

The debug probe and USB are not isolated in configuration 1 since JP2 and JP3 are connected. The 5 V supply is coming from the USB directly to the device side of the LaunchPad and can be used to power other devices connected to the BoosterPack headers. In this configuration, do not connect JP6 as there may be contention between the 5 V from the USB (JP3) and the 5 V from the on-board step-up regulator, U12.

Configuration 2 is an isolated configuration where 3.3 V is supplied any way other than through JP1. In this configuration, JP6 is connected allowing the 3.3 V to be stepped up to 5 V with the on-board step-up regulator, U12. In this configuration ensure that no other 5 V source is connected to the BoosterPack headers or through J16.

Configuration 3 is another isolated configuration since JP2 and JP3 are not connected. With JP6 disconnected, 5 V must be supplied through an external connection on the BoosterPack headers or J16. Notice that this configuration does not rely on the 3.3 V supply being powered to provide the 5 V. To supply 3.3 V to the device in an isolated configuration, see [Table 1](#).

Table 2. Supplying the LaunchPad With 5 V

| Configuration | JP2 | JP3 | JP6 | External 5 V | USB | JTAG/USB Isolation Status |
|---------------|-----|-----|-----|--------------|------------|---------------------------|
| 1 | Yes | Yes | No | No | Yes | Not Isolated |
| 2 | No | No | Yes | No | Don't Care | Isolated |
| 3 | No | No | No | Yes | Don't Care | Isolated |

5.3 Boot Mode Selection

The LaunchPad's F28379D device includes a boot ROM that performs some basic start-up checks and allows for the device to boot in many different ways. Most users will either want to perform an emulation boot or a boot to flash (if they are running the application standalone). Switch S1 has been provided to allow users to easily configure the pins that the bootROM checks to make this decision. The positions on S1 correspond to those shown in [Table 3](#).

Table 3. Positions of Signals Present on Switch S1

| Positions | Function |
|-----------|----------|
| 1 | GPIO84 |
| 2 | GPIO72 |
| 3 | TRSTn |

Keep in mind that the debug probe does not connect if the device is not in the emulation boot mode (TRST switch in the UP-1 position). More information about boot mode selection can be found in the *Boot ROM* section of the [TMS320F2837xD Dual-Core Delfino Microcontrollers Technical Reference Manual](#).

5.4 Connecting a BoosterPack

The F2837xD LaunchPad is the perfect experimenter board to start hardware development with the F2837xD devices. All of the connectors are aligned in a 0.1-in (2.54-mm) grid to allow easy and inexpensive development of add on boards called BoosterPacks. These satellite boards can access all of the GPIO and analog signals. The pinout of the connectors can be found in [Section 5](#).

5.5 GPIO Routing Between BoosterPack and I/O Expansion Headers

This LaunchPad has a high-density connector (J9) on the backside of the board. This connector provides for an IO expansion board to be connected. Many of the EMIF1 signals are available as well as SPI and I2C. Some of the signals present on J9 are also available on the BoosterPack expansion headers.

On Revision 1.x LaunchPads, only two signals were dual-mapped to both J9 and the BoosterPack Headers, GPIO40 and GPIO41. To select the destination, the three-position jumpers, J11 and J13, could be adjusted accordingly. Placing the jumper between position 1 and position 2 will route the signal to J9. Placing the jumper between position 2 and position 3 will route the signal to the BoosterPack headers.

On revision 2.0 LaunchPads, in addition to GPIO40 and GPIO41, four more signals may be routed to either the BoosterPack headers or J9 independently, or may be connected to both based on the placement of 0Ω resistors. By default, the signals are only routed to the BoosterPack headers for alignment with the BoosterPack standards. [Table 4](#) provides the mapping for each signal and which resistors populate in order to route the signal as desired. Refer to the schematic at the end of this document in [Section 6.2](#), or located in the C2000Ware directory.

Table 4. Revision 2.0: Resistor Selection for Routing Dual-Mapped Signals

| GPIO | Route to BoosterPack Headers | Route to J9 Header |
|---------|------------------------------|--------------------|
| GPIO29 | R75 | R76 |
| GPIO40 | R67 | R68 |
| GPIO41 | R69 | R70 |
| GPIO52 | R77 | R78 |
| GPIO104 | R71 | R72 |
| GPIO105 | R73 | R74 |

6 LAUNCHXL-F28379D Hardware

6.1 Device Pin Out

Table 5 through Table 8 lists the pin out and pin mux options for the C2000 LaunchPad. Additional muxing options are available and can be found in the [TMS320F2837xD Dual-Core Delfino™ Microcontrollers Data Manual](#).

Table 5. F28379D LaunchPad Pin Out and Pin Mux Options - J1, J3

| Mux Value | | | | J1 Pin | J3 Pin | Mux Value | | | |
|------------------------|---------|------|------------------------|-----------|-----------|-----------|--------------|---|---|
| X | 2 | 1 | 0 | | | 0 | Alt Function | 2 | X |
| | | | 3.3V | 1 | 21 | 5V | | | |
| | | | GPIO32 | 2 | 22 | GND | | | |
| | SCIRXDB | | GPIO19 | 3 | 23 | ADCIN14 | CMPIN4P | | |
| | SCITXDB | | GPIO18 | 4 | 24 | ADCINC3 | CMPIN6N | | |
| | | | GPIO67 | 5 | 25 | ADCINB3 | CMPIN3N | | |
| | | | GPIO111 | 6 | 26 | ADCINA3 | CMPIN1N | | |
| SPICLKA ⁽¹⁾ | | | GPIO60 | 7 | 27 | ADCINC2 | CMPIN6P | | |
| | | | GPIO22 | 8 | 28 | ADCINB2 | CMPIN3P | | |
| | | SCLA | GPIO105 ⁽²⁾ | 9 | 29 | ADCINA2 | CMPIN1P | | |
| | | SDAA | GPIO104 ⁽²⁾ | 10 | 30 | ADCINA0 | DACOUTA | | |

⁽¹⁾ For full pin muxing table for functions shown here and additional mux options, see the [TMS320F2837xD Dual-Core Delfino™ Microcontrollers Data Manual](#).

⁽²⁾ This signal is also routed to the IO expansion header, J9. For information on how to configure this signal, see [Section 5.5](#).

Table 6. F28379D LaunchPad Pin Out and Pin Mux Options - J4, J2

| Mux Value | | | | J4 Pin | J2 Pin | Mux Value | | | |
|----------------------------|---|-------------|--------|-----------|-----------|-----------------------|---|---|----------------------------|
| X | 2 | 1 | 0 | | | 0 | 1 | 2 | X |
| | | EPWM1A | GPIO0 | 40 | 20 | GND | | | |
| | | EPWM1B | GPIO1 | 39 | 19 | GPIO61 | | | |
| | | EPWM2A | GPIO2 | 38 | 18 | GPIO123 | | | SD1_C1 ⁽¹⁾ |
| | | EPWM2B | GPIO3 | 37 | 17 | GPIO122 | | | SD1_D1 ⁽¹⁾ |
| | | EPWM3A | GPIO4 | 36 | 16 | RST | | | |
| | | EPWM3B | GPIO5 | 35 | 15 | GPIO58 | | | SPISIMOA ⁽¹⁾ |
| | | OUTPUTXBAR1 | GPIO24 | 34 | 14 | GPIO59 | | | SPISOMIA ⁽¹⁾ |
| OUTPUTXBAR7 ⁽¹⁾ | | | GPIO16 | 33 | 13 | GPIO124 | | | SD1_D2 ⁽¹⁾ |
| | | | DAC1 | 32 | 12 | GPIO125 | | | SD1_C2 ⁽¹⁾ |
| | | | DAC2 | 31 | 11 | GPIO29 ⁽²⁾ | | | OUTPUTXBAR6 ⁽¹⁾ |

⁽¹⁾ For full pin muxing table for functions shown here and additional mux options, see the [TMS320F2837xD Dual-Core Delfino™ Microcontrollers Data Manual](#).

⁽²⁾ This signal is also routed to the IO expansion header, J9. For information on how to configure this signal, see [Section 5.5](#).

Table 7. F28379D LaunchPad Pin Out and Pin Mux Options - J5, J7

| X | Mux Value | | | J5 Pin | J7 Pin | Mux Value | | | |
|------------------------|-----------|---|-----------------------|-----------|-----------|-----------|--------------|---|---|
| | 2 | 1 | 0 | | | 0 | Alt Function | 2 | X |
| | | | 3.3V | 41 | 61 | 5V | | | |
| | | | GPIO95 | 42 | 62 | GND | | | |
| SCIRXDC ⁽¹⁾ | | | GPIO139 | 43 | 63 | ADCIN15 | CMPIN4N | | |
| SCITXDC ⁽¹⁾ | | | GPIO56 | 44 | 64 | ADCINC5 | CMPIN5N | | |
| | | | GPIO97 | 45 | 65 | ADCINB5 | | | |
| | | | GPIO94 | 46 | 66 | ADCINA5 | CMPIN2N | | |
| SPICLKB ⁽¹⁾ | | | GPIO65 | 47 | 67 | ADCINC4 | CMPIN5P | | |
| | | | GPIO52 ⁽²⁾ | 48 | 68 | ADCINB4 | | | |
| SCLB ⁽¹⁾ | | | GPIO41 ⁽²⁾ | 49 | 69 | ADCINA4 | CMPIN2P | | |
| SDAB ⁽¹⁾ | | | GPIO40 ⁽²⁾ | 50 | 70 | ADCINA1 | DACOUTB | | |

⁽¹⁾ For full pin muxing table for functions shown here and additional mux options, see the [TMS320F2837xD Dual-Core Delfino™ Microcontrollers Data Manual](#).

⁽²⁾ This signal is also routed to the IO expansion header, J9. For information on how to configure this signal, see [Section 5.5](#).

Table 8. F28379D LaunchPad Pin Out and Pin Mux Options - J8, J6

| X | Mux Value | | | J8 Pin | J6 Pin | Mux Value | | | |
|----------------------------|-----------|--------|--------|-----------|-----------|-----------|---|---|----------------------------|
| | 2 | 1 | 0 | | | 0 | 1 | 2 | X |
| | | EPWM4A | GPIO6 | 80 | 60 | GND | | | |
| | | EPWM4B | GPIO7 | 79 | 59 | GPIO66 | | | |
| | | EPWM5A | GPIO8 | 78 | 58 | GPIO131 | | | SD2_C1 ⁽¹⁾ |
| | | EPWM5B | GPIO9 | 77 | 57 | GPIO130 | | | SD2_D1 ⁽¹⁾ |
| | | EPWM6A | GPIO10 | 76 | 56 | RST | | | |
| | | EPWM6B | GPIO11 | 75 | 55 | GPIO63 | | | SPISIMOB ⁽¹⁾ |
| OUTPUTXBAR3 ⁽¹⁾ | | | GPIO14 | 74 | 54 | GPIO64 | | | SPISOMIB ⁽¹⁾ |
| OUTPUTXBAR4 ⁽¹⁾ | | | GPIO15 | 73 | 53 | GPIO26 | | | SD2_D2 ⁽¹⁾ |
| | | | DAC3 | 72 | 52 | GPIO27 | | | SD2_C2 ⁽¹⁾ |
| | | | DAC4 | 71 | 51 | GPIO25 | | | OUTPUTXBAR2 ⁽¹⁾ |

⁽¹⁾ For full pin muxing table for functions shown here and additional mux options, see the [TMS320F2837xD Dual-Core Delfino™ Microcontrollers Data Manual](#).

6.2 Schematics

The following figures show the LAUNCHXL-F28379D Rev 2.0 schematic. The schematics for both LAUNCHXL-F28379D Revision 2.0 and Revision 1.1 are located in C2000Ware.

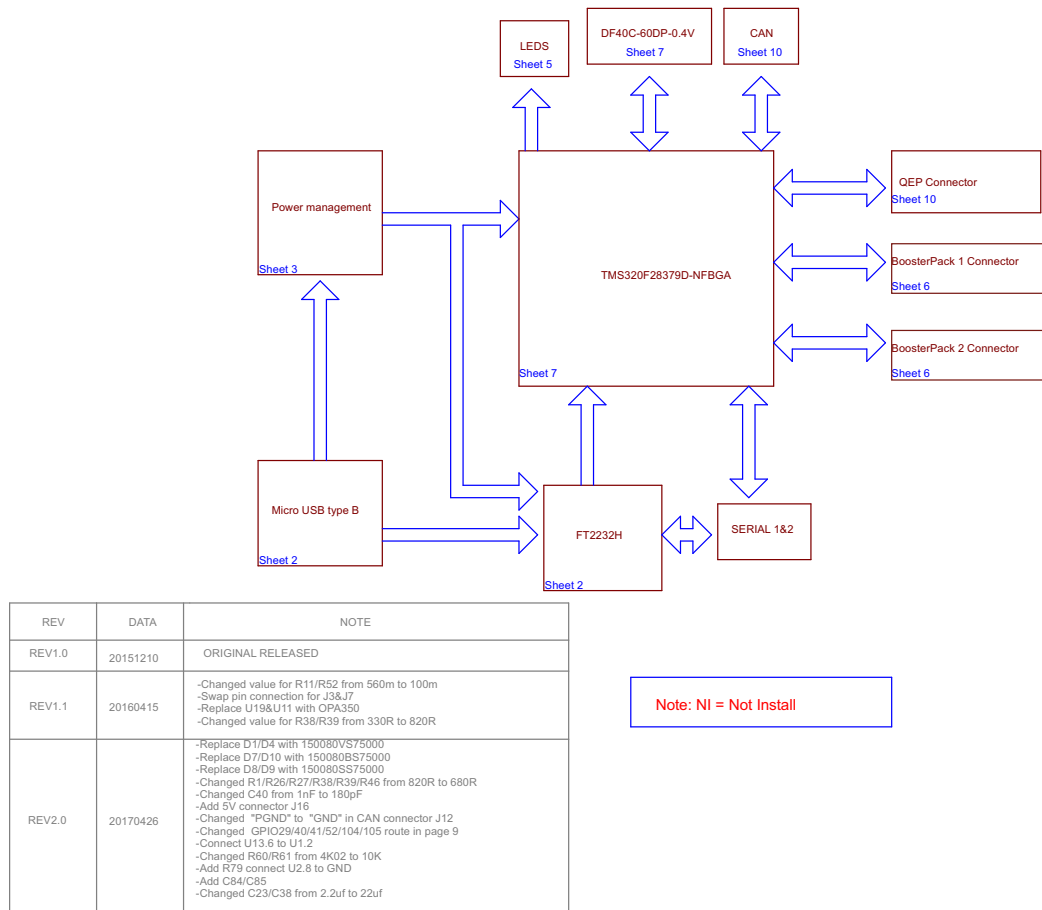

Copyright © 2017, Texas Instruments Incorporated

Figure 2. P01_Block Diagram

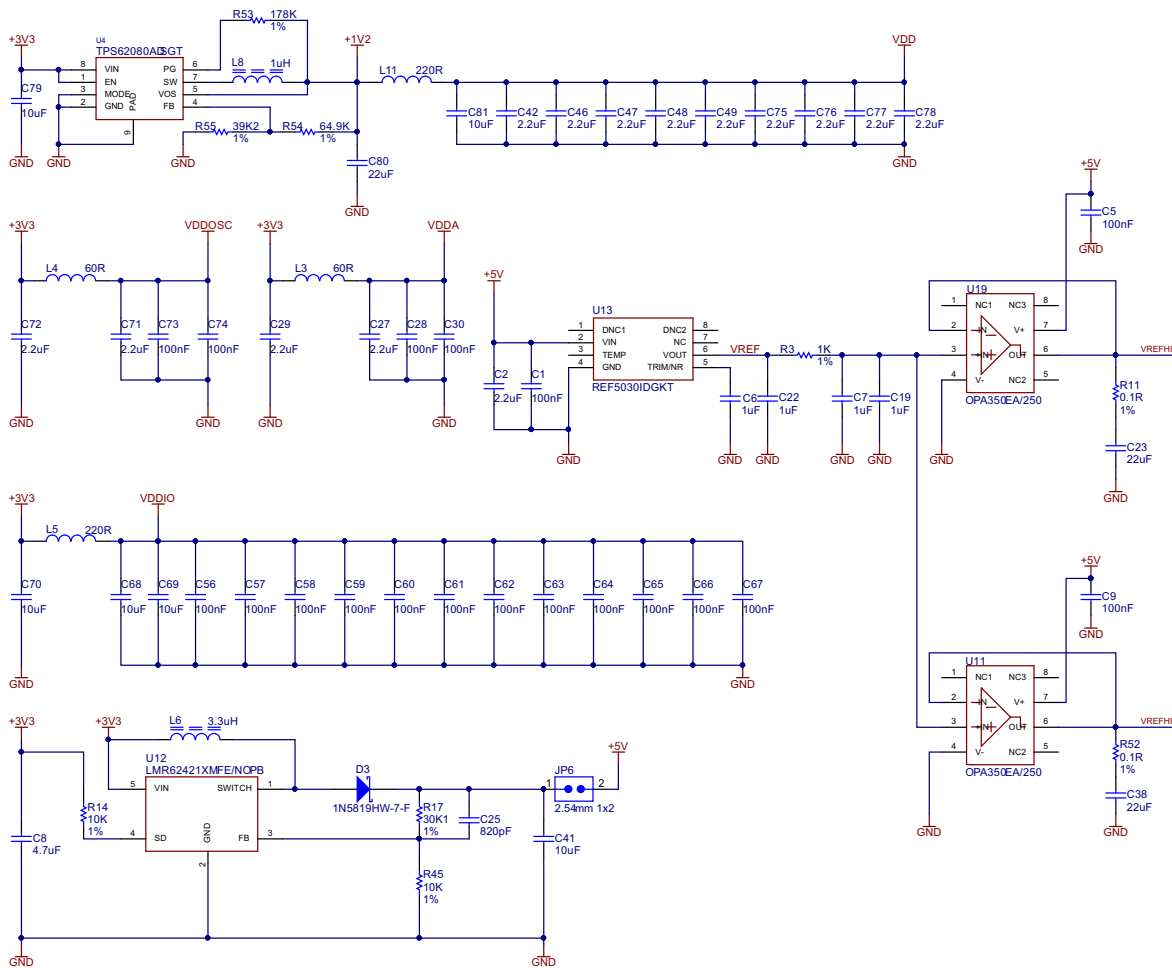

Copyright © 2017, Texas Instruments Incorporated

Figure 4. P03_Power

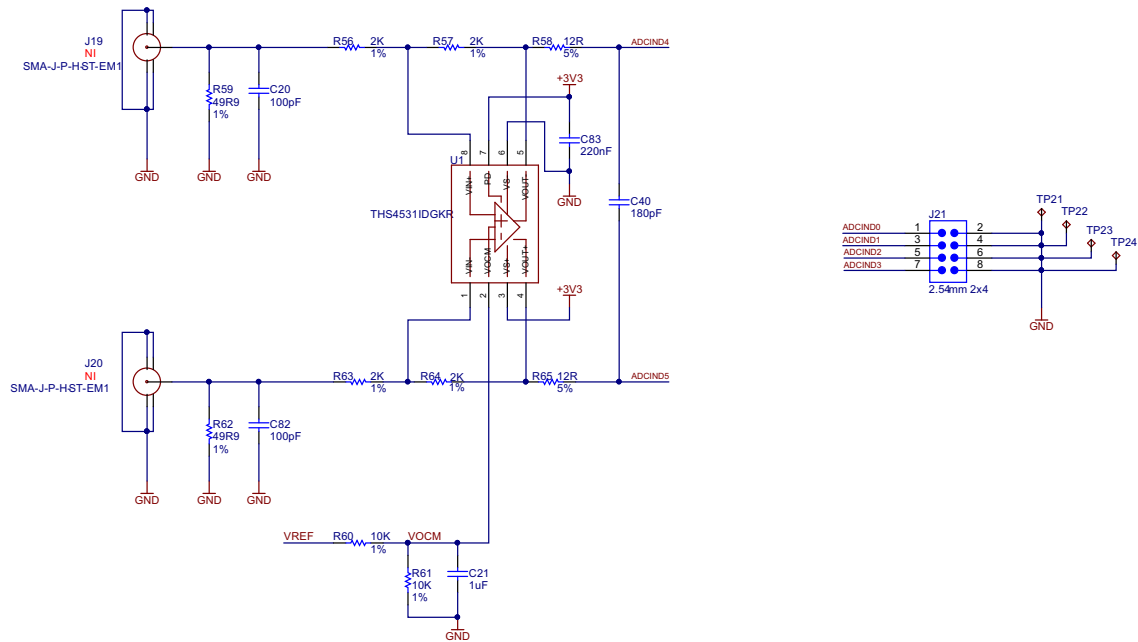

Copyright © 2017, Texas Instruments Incorporated

Figure 5. P04_ADCIND



Copyright © 2017, Texas Instruments Incorporated

Figure 6. P05_PWM-DAC

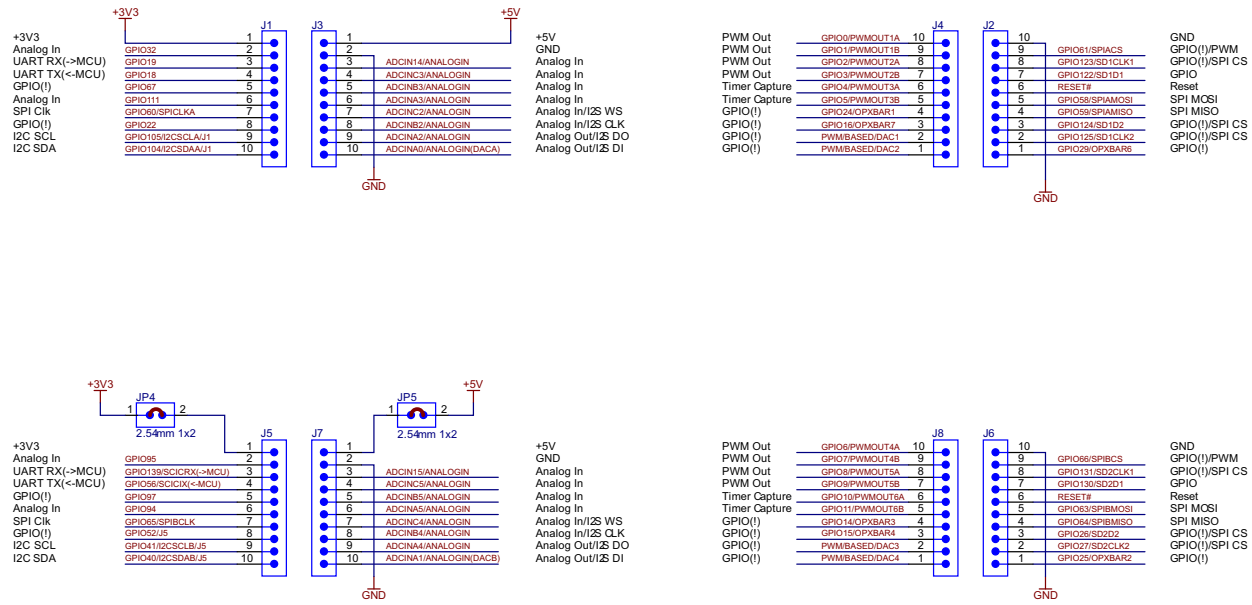

Copyright © 2017, Texas Instruments Incorporated

Figure 7. P06_BoosterPack Headers

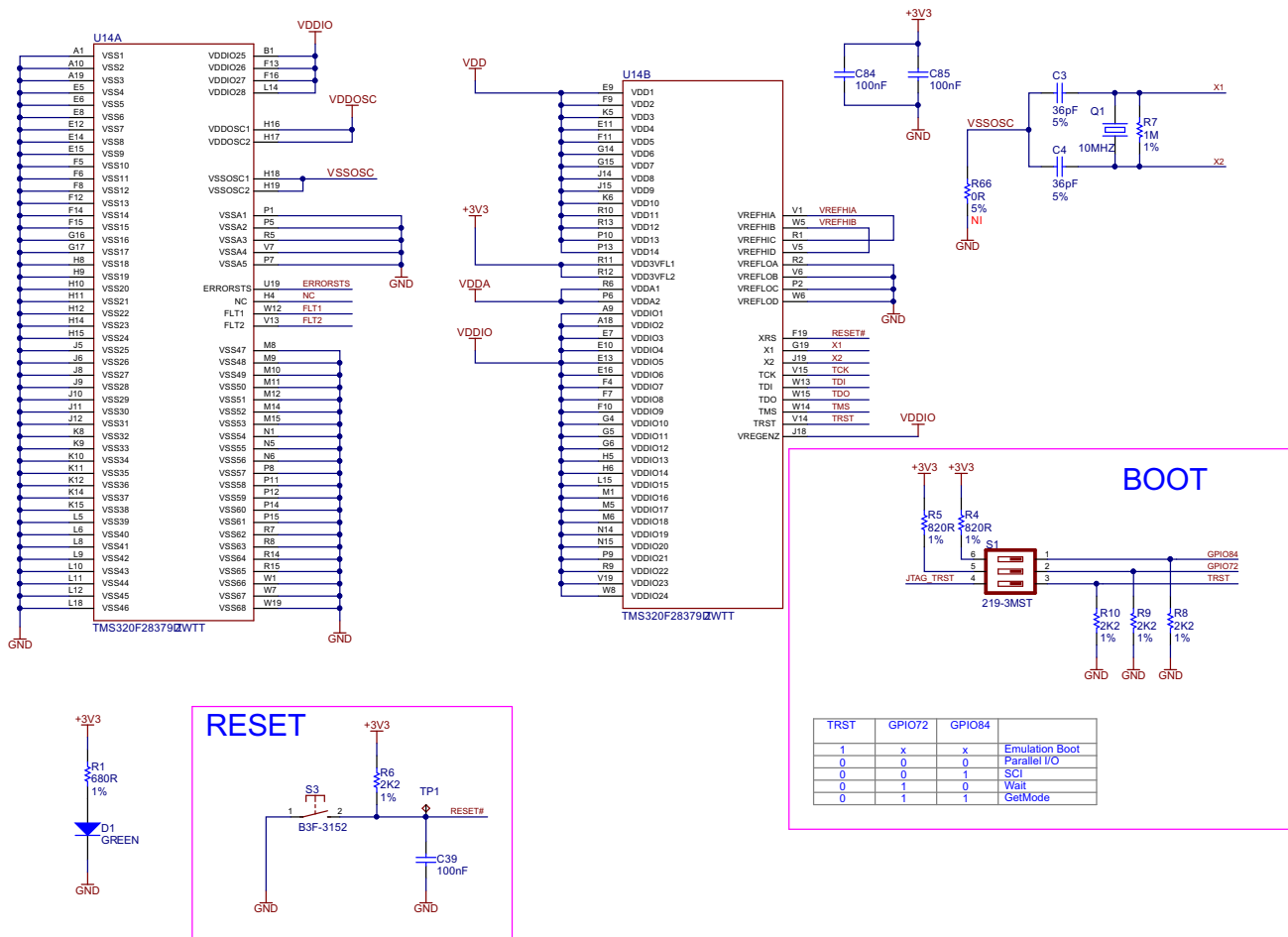

Copyright © 2017, Texas Instruments Incorporated

Figure 8. P07_F28379D-PWR

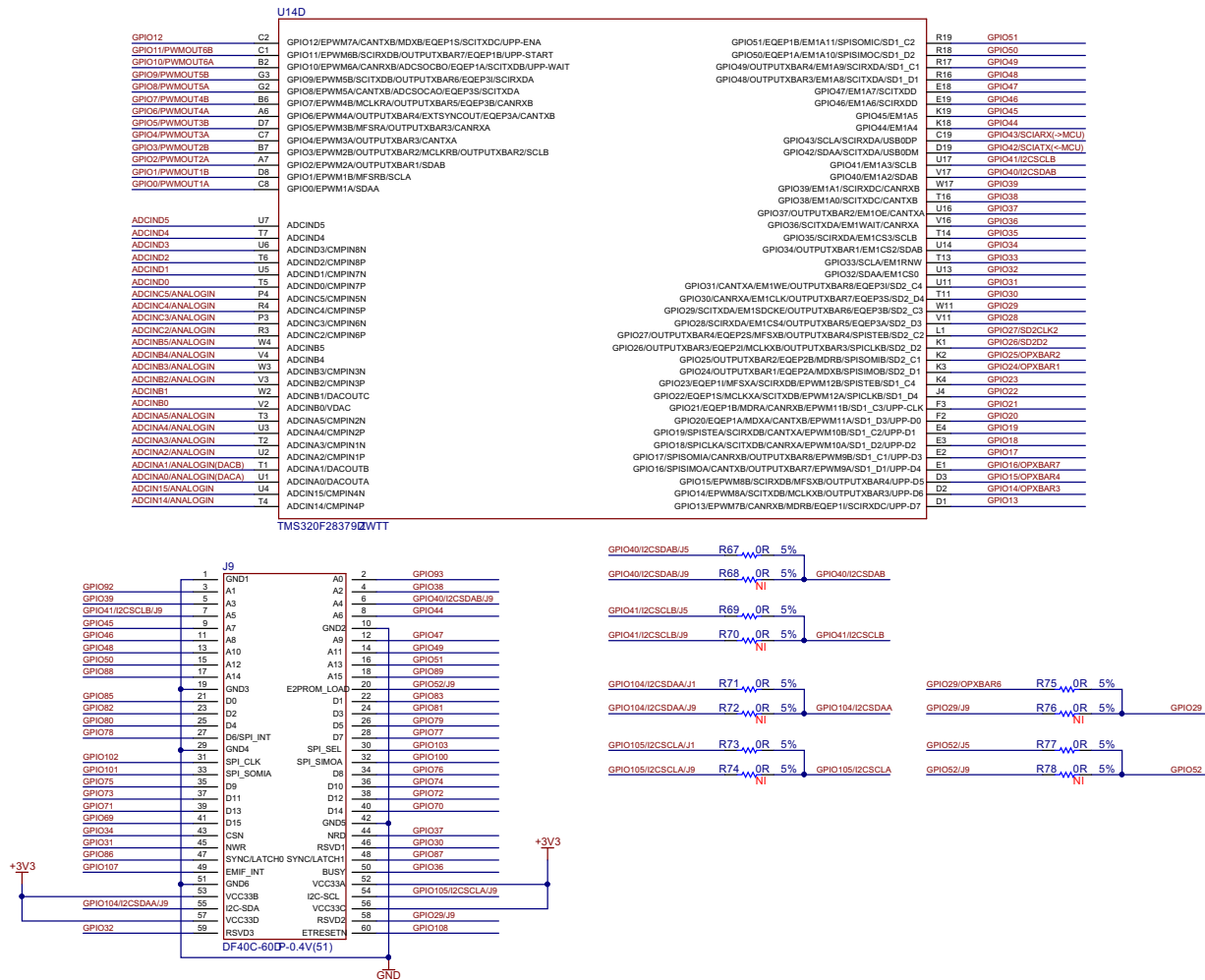
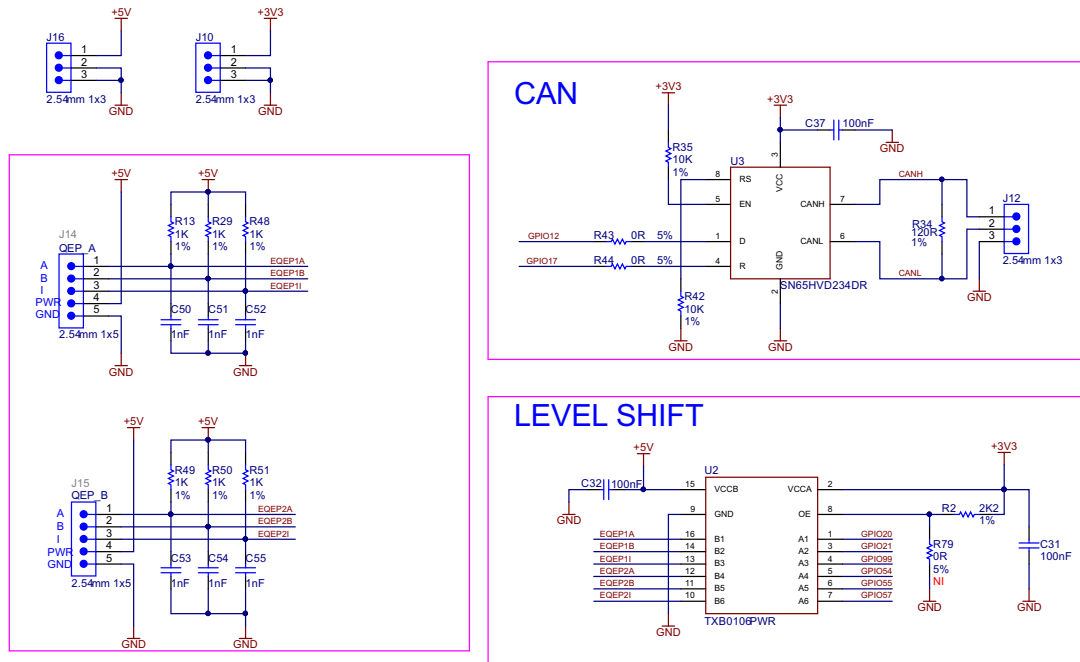

Figure 10. P09_F28379_IO2



Copyright © 2017, Texas Instruments Incorporated

Figure 11. P10_EX-Headers

6.3 PCB Layout

Figure 12 through Figure 21 show the LAUNCHXL-F28379D Rev 2.0 PCB layout. The gerber files and PCB layout for both LAUNCHXL-F28379D Revision 2.0 and Revision 1.1 can be found in C2000Ware.

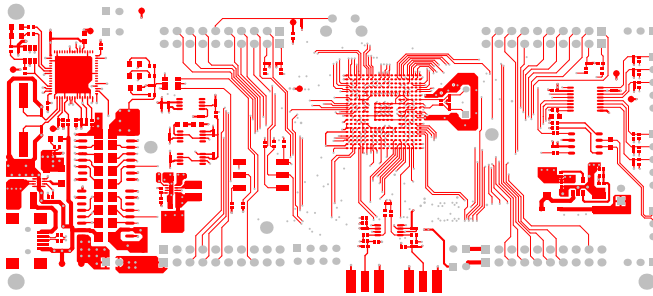

Figure 12. Top

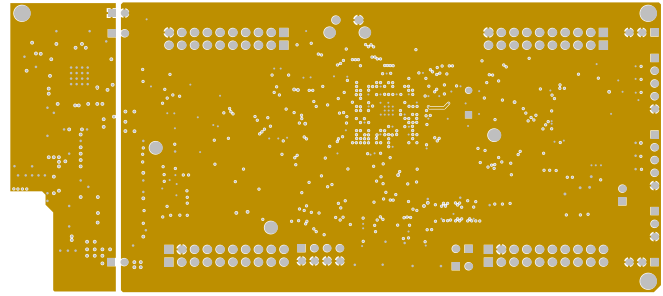

Figure 13. GND

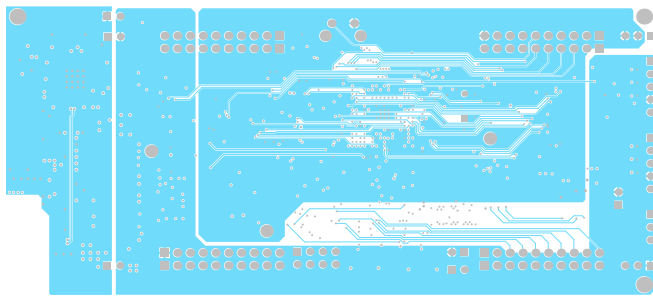

Figure 14. Route1

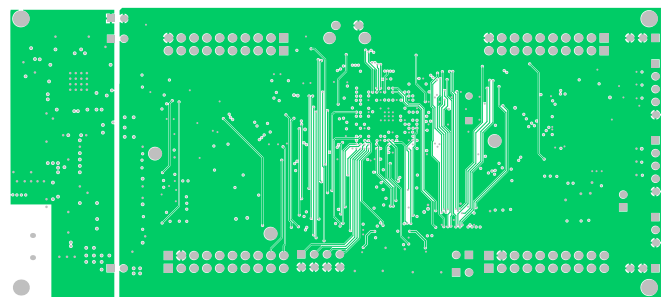

Figure 15. Route2

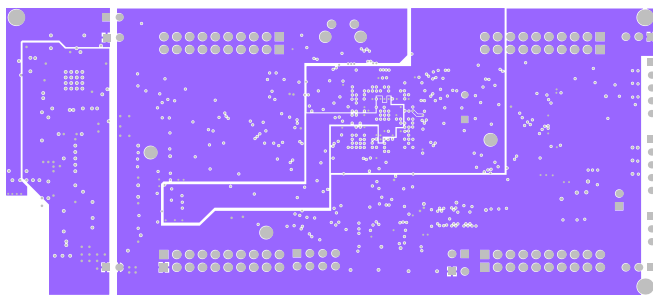

Figure 16. VDD

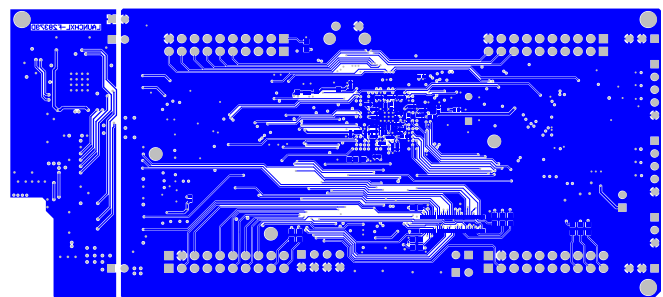

Figure 17. Bottom

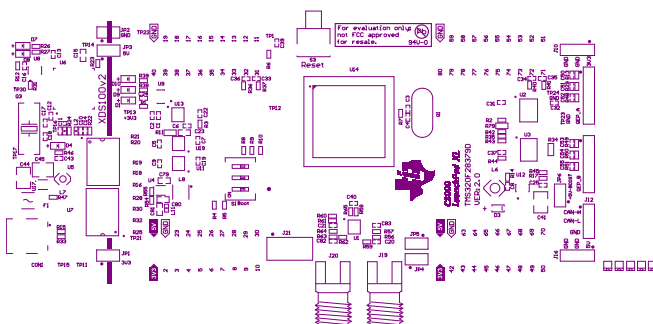

Figure 18. Top Silkscreen Overlay

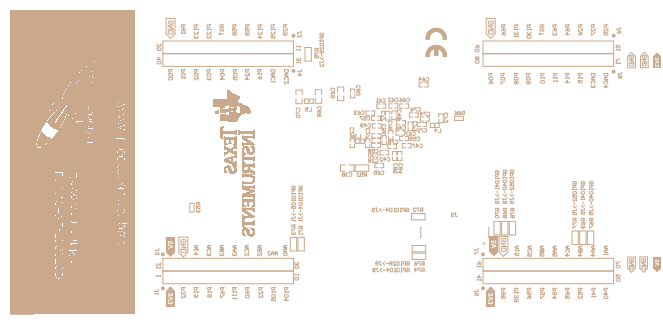

Figure 19. Bottom Silkscreen Overlay

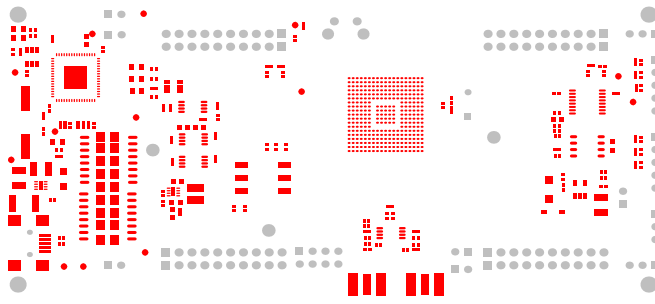

Figure 20. Top Pad Master

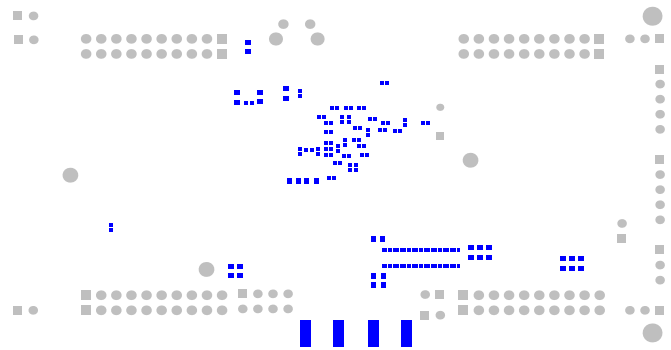

Figure 21. Bottom Pad Master

6.4 Bill of Materials (BOM)

Table 9 lists the LAUNCHXL-F28379D bill of materials.

Table 9. LAUNCHXL-F28379D Bill of Materials

| Item # | Note | Part Number | Qty | REF Desig nator | Manufacturer (Digi-Key) | Description | ROHS (Digi-Key) | Lead Free Status | Reach Status (Digi-Key) | Reach Effective Date (Digi-Key) | Availability | Description (Digi-Key) | Manufacturer Part Number (Digi-Key) | Digi-Key Part Number (Digi-Key) |
|--------|------------------|-----------------------------|-----|-----------------|-------------------------|--|-----------------|------------------|-------------------------|---------------------------------|--------------|----------------------------------|-------------------------------------|---------------------------------|
| 1 | PCB | LAUNCHXL-F28379D PCB rev2.0 | 1 | PCB | | 6 layers, red soldermask, white silkscreen, 130*59mm, ENIG, Launchxl-F28379D Rev2.0 pcb | | | | | | | | |
| 2 | MCU | TMS320F28379DZ WTT | 1 | U14 | Texas Instruments | IC, MCU 32BIT 1024KB, TMS320F28379DZ WTT, BGA-337, SMD, customer supply | YES | Lead Free | Reach Not Affected | Jun-2016 | Non-Stock | IC MCU 32BIT 1MB FLASH 337NFBGA | TMS320F28379DZ WTT | TMS320F28379DZ WTT-ND |
| 3 | Memory | 93LC56BT-I/OT | 1 | U8 | Microchip Technology | IC, EEPROM Serial-Microwire 2K-Bit 128 x 16 2MHZ, 93LC56BT-I/OT, SOT-23-6, SMD | YES | Lead Free | Reach Not Affected | Jan-2017 | Active | IC EEPROM 2KBIT 2MHZ SOT23-6 | 93LC56BT-I/OT | 93LC56BT-I/OTCT-ND |
| 4 | Power Management | REF5030IDGKT | 1 | U13 | Texas Instruments | IC 7V-Ref Precision 3V 10mA 8-Pin VSSOP T/R | YES | Lead Free | Reach Not Affected | Jun-2016 | Active | IC VREF SERIES 3V 8VSSOP | REF5030IDGKT | 296-24501-1-ND |
| 5 | DC-DC | LMR62421XMFE/N OPB | 1 | U12 | Texas Instruments | Conv DC-DC Single Step Up 2.7V to 5.5V 5-Pin SOT-23 T/R ,CUSTOMER SUPPLY | YES | Lead Free | Reach Not Affected | Jun-2016 | Active | IC REG BST SEPIC ADJ 2.1A SOT23 | LMR62421XMFE/NOBP | LMR62421XMFE/N OPBCT-ND |
| 6 | DC-DC | TPS62080ADSGT | 1 | U4 | Texas Instruments | IC REG BUCK SYNC ADJ 1.2A 8WSON | YES | Lead Free | Reach Not Affected | Jun-2016 | Active | IC REG BUCK ADJ 1.2A SYNC 8WSON | TPS62080ADSGT | 296-30360-1-ND |
| 7 | DC-DC | TPS62162DSGT | 1 | U17 | Texas Instruments | IC REG BUCK SYNC 3.3V 1A 8WSON | YES | Lead Free | Reach Not Affected | Jun-2016 | Active | IC REG BUCK 3.3V 1A SYNC 8WSON | TPS62162DSGT | 296-29897-1-ND |
| 8 | Amplifier | THS4531IDGKR | 1 | U1 | Texas Instruments | IC OPAMP DIFF 27MHZ RRO 8VSSOP TR | YES | Lead Free | Reach Not Affected | Jun-2016 | Active | IC OPAMP DIFF 27MHZ RRO 8VSSOP | THS4531IDGKR | 296-30342-1-ND |
| 9 | Amplifier | OPA350EA/250 | 2 | U11,U19 | Texas Instruments | IC OPAMP GP 38MHZ RRO 8VSSOP T/R | YES | Lead Free | Reach Not Affected | Jun-2016 | Active | IC OPAMP GP 38MHZ RRO 8VSSOP | OPA350EA/250 | OPA350EACT-ND |
| 10 | Logic | TXB0106PWR | 1 | U2 | Texas Instruments | IC, 6-bit bidirectional voltage-level translator with auto-direction sensing and ±15-kV ESD protection, TXB0106PWR, TSSOP-16, SMD, Customer Supply | YES | Lead Free | Reach Not Affected | Jun-2016 | Active | IC 6BIT NON-INV TRANSLTR 16TSSOP | TXB0106PWR | 296-23759-1-ND |
| 11 | Logic | SN74LVC2G07DBV R | 1 | U9 | Texas Instruments | Buffer/Driver 2-CH Non-Inverting Open Drain CMOS 6-Pin SOT-23 T/R, CUSTOMER SUPPLY | YES | Lead Free | Reach Not Affected | Jun-2016 | Active | IC BUFF/DVR DL NON-INV SOT23-6 | SN74LVC2G07DBV R | 296-13494-1-ND |

Table 9. LAUNCHXL-F28379D Bill of Materials (continued)

| Item # | Note | Part Number | Qty | REF Designator | Manufacturer (Digi-Key) | Description | ROHS (Digi-Key) | Lead Free Status | Reach Status (Digi-Key) | Reach Effective Date (Digi-Key) | Availability | Description (Digi-Key) | Manufacturer Part Number (Digi-Key) | Digi-Key Part Number (Digi-Key) |
|--------|---------------------|------------------|-----|---|---|--|-----------------|------------------|-------------------------|---------------------------------|--------------|---------------------------------|-------------------------------------|---------------------------------|
| 12 | Interface | FT2232HQ-REEL | 1 | U6 | FTDI, Future Technology Devices International Ltd | IC,Dual High Speed USB to Multipurpose UART/FIFO IC,FT2232HQ-REEL,QFN-64,SMD | YES | Lead Free | Reach Not Affected | Jan-2017 | Active | IC USB HS DUAL UART/FIFO 64-QFN | FT2232HQ-REEL | 768-1025-1-ND |
| 13 | Interface | SN65HVD234DR | 1 | U3 | Texas Instruments | IC CAN transceiver 3.3V 8-SOIC | YES | Lead Free | Reach Not Affected | Jun-2016 | Active | IC CAN TRANSCEIVER 3.3V 8-SOIC | SN65HVD234DR | 296-27991-1-ND |
| 14 | Isolator | ISO7231CDWR | 1 | U7 | Texas Instruments | IC DGTL ISO 3CH CMOS 16SOIC,CUSTOMER SUPPLY | YES | Lead Free | Reach Not Affected | Jun-2016 | Active | DGTL ISO 2.5KV GEN PURP 16SOIC | ISO7231CDWR | 296-38966-1-ND |
| 15 | Isolator | ISO7240CDWR | 1 | U5 | Texas Instruments | IC DGTL ISO 4CH CMOS 16SOIC,CUSTOMER SUPPLY | YES | Lead Free | Reach Not Affected | Jun-2016 | Active | DGTL ISO 2.5KV GEN PURP 16SOIC | ISO7240CDWR | 296-38555-1-ND |
| 16 | Thick film Resistor | RC0402JR-070RL | 4 | R15, R33, R43, R44 | Yageo | RES,0R,±5%,1/16W, SMD0402 | YES | Lead Free | Reach Not Affected | Dec-2015 | Active | RES SMD 0.0Ω JUMPER 1/16W 0402 | RC0402JR-070RL | 311-0.0JRCT-ND |
| 17 | Thick film Resistor | RC0402FR-0749R9L | 2 | R59, R62 | Yageo | RES,49R9,±1%,1/16W, SMD0402 | YES | Lead Free | Reach Not Affected | Jan-2017 | Active | RES SMD 49.9 Ω 1% 1/16W 0402 | RC0402FR-0749R9L | 311-49.9LRCT-ND |
| 18 | Thick film Resistor | RC0402FR-071KL | 13 | R3,R13, R22, R23, R29, R36, R37, R40, R41, R48, R49, R50, R51 | Yageo | RES,1K,±1%,1/16W, SMD0402 | YES | Lead Free | Reach Not Affected | Jan-2017 | Active | RES SMD 1K Ω 1% 1/16W 0402 | RC0402FR-071KL | 311-1.00KLRCT-ND |
| 19 | Thick film Resistor | RC0402FR-072KL | 4 | R56, R57, R63, R64 | Yageo | RES,2K,±1%,1/16W, SMD0402 | YES | Lead Free | Reach Not Affected | Jan-2017 | Active | RES SMD 2K Ω 1% 1/16W 0402 | RC0402FR-072KL | 311-2KLRCT-ND |
| 20 | Thick film Resistor | RC0402FR-072K2L | 6 | R2, R6, R8, R9, R10, R31 | Yageo | RES,2K2,±1%,1/16W, SMD0402 | YES | Lead Free | Reach Not Affected | Jan-2017 | Active | RES SMD 2.2K Ω 1% 1/16W 0402 | RC0402FR-072K2L | 311-2.20KLRCT-ND |
| 21 | Thick film Resistor | RC0402FR-0710KL | 7 | R12, R14, R35, R42, R45,R60, R61 | Yageo | RES,10K,±1%,1/16W, SMD0402 | YES | Lead Free | Reach Not Affected | Jan-2017 | Active | RES SMD 10K Ω 1% 1/16W 0402 | RC0402FR-0710KL | 311-10.0KLRCT-ND |
| 22 | Thick film Resistor | RC0402FR-0712KL | 1 | R24 | Yageo | RES,12K,±1%,1/16W, SMD0402 | YES | Lead Free | Reach Not Affected | Jan-2017 | Active | RES SMD 12K Ω 1% 1/16W 0402 | RC0402FR-0712KL | 311-12.0KLRCT-ND |
| 23 | Thick film Resistor | RC0402FR-0730K1L | 1 | R17 | Yageo | RES,30K1,±1%,1/16W, SMD0402 | YES | Lead Free | Reach Not Affected | Jan-2017 | Active | RES SMD 30.1K Ω 1% 1/16W 0402 | RC0402FR-0730K1L | 311-30.1KLRCT-ND |
| 24 | Thick film Resistor | RC0402FR-0739K2L | 1 | R55 | Yageo | RES,39K2,±1%,1/16W, SMD0402 | YES | Lead Free | Reach Not Affected | Jan-2017 | Active | RES SMD 39.2K Ω 1% 1/16W 0402 | RC0402FR-0739K2L | 311-39.2KLRCT-ND |
| 25 | Thick film Resistor | RC0402FR-07100KL | 1 | R47 | Yageo | RES,100K,±1%,1/16W, SMD0402 | YES | Lead Free | Reach Not Affected | Jan-2017 | Active | RES SMD 100K Ω 1% 1/16W 0402 | RC0402FR-07100KL | 311-100KLRCT-ND |

Table 9. LAUNCHXL-F28379D Bill of Materials (continued)

| Item # | Note | Part Number | Qty | REF Designator | Manufacturer (Digi-Key) | Description | ROHS (Digi-Key) | Lead Free Status | Reach Status (Digi-Key) | Reach Effective Date (Digi-Key) | Availability | Description (Digi-Key) | Manufacturer Part Number (Digi-Key) | Digi-Key Part Number (Digi-Key) |
|--------|---------------------|---------------------|-----|------------------------------|----------------------------------|---|-----------------|------------------|-------------------------|---------------------------------|--------------|--------------------------------|-------------------------------------|---------------------------------|
| 26 | Thick film Resistor | RC0402FR-071ML | 1 | R7 | Yageo | RES,1M,±1%,1/16W, SMD0402 | YES | Lead Free | Reach Not Affected | Jan-2017 | Active | RES SMD 1M Ω 1% 1/16W 0402 | RC0402FR-071ML | 311-1.00MLRCT-ND |
| 27 | Thick film Resistor | RC0603JR-070RL | 6 | R67,R69, R71,R73, R75,R77 | Yageo | RES,0R,±5%,1/10W, SMD0603 | YES | Lead Free | Reach Not Affected | Dec-2015 | Active | RES SMD 0.0Ω JUMPER 1/10W 0603 | RC0603JR-070RL | 311-0.0GRCT-ND |
| 28 | Thick film Resistor | RL0603FR-070R1L | 2 | R11,R52 | Yageo | RES,0R1,±1%,1/10W, SMD0603 | YES | Lead Free | Reach Not Affected | Jan-2017 | Active | RES SMD 0.1 Ω 1% 1/10W 0603 | RL0603FR-070R1L | 311-1.10QCT-ND |
| 29 | Thick film Resistor | RC0603FR-07120RL | 1 | R34 | Yageo | RES,120R,±1%,1/10W, SMD0603 | YES | Lead Free | Reach Not Affected | Jan-2017 | Active | RES SMD 120 Ω 1% 1/10W 0603 | RC0603FR-07120RL | 311-120HRCT-ND |
| 30 | Thick film Resistor | RC0402FR-07820RL | 2 | R4, R5 | Yageo | RES,820R,±1%,1/16W, SMD0402 | YES | Lead Free | Reach Not Affected | Jan-2017 | Active | RES SMD 820 Ω 1% 1/16W 0402 | RC0402FR-07820RL | 311-820LRCT-ND |
| 31 | Thick film Resistor | RC0402FR-07680RL | 6 | R1,R26,R 27,R38,R 39, R46 | Yageo | RES,680R,±1%,1/16W, SMD0402 | YES | Lead Free | Reach Not Affected | Jan-2017 | Active | RES SMD 680 Ω 1% 1/16W 0402 | RC0402FR-07680RL | 311-680LRCT-ND |
| 32 | Thick film Resistor | ERJ-2RKF1783X | 1 | R53 | Panasonic Electronic Components | RES, 178K Ω, 1%, 1/10W, SMD0402 | YES | Lead Free | Reach Not Affected | Jan-2017 | Active | RES SMD 178K Ω 1% 1/10W 0402 | ERJ-2RKF1783X | P178KLCT-ND |
| 33 | Thick film Resistor | ERJ-2RKF6492X | 1 | R54 | Panasonic Electronic Components | RES, 64.9K Ω, 1%, 1/10W, SMD0402 | YES | Lead Free | Reach Not Affected | Jan-2017 | Active | RES SMD 64.9K Ω 1% 1/10W 0402 | ERJ-2RKF6492X | P64.9KLCT-ND |
| 34 | Thick film Resistor | CRCW040212R0JN ED | 2 | R58, R65 | Vishay Dale | RES SMD 12 Ω 5% 1/16W 0402 TR | YES | Lead Free | Reach Not Affected | Dec-2015 | Active | RES SMD 12 Ω 5% 1/16W 0402 | CRCW040212R0JN ED | 541-12JCT-ND |
| 35 | Ceramic Capacitor | GRM1555C1H101J A01D | 2 | C20, C82 | Murata Electronics North America | CAP,100PF,±5%,C0G, 50V,SMD0402 | YES | Lead Free | Reach Not Affected | Jun-2016 | Active | CAP CER 100PF 50V C0G/NP0 0402 | GRM1555C1H101J A01D | 490-5922-1-ND |
| 36 | Ceramic Capacitor | GRM1555C1H181J A01D | 1 | C40 | Murata Electronics North America | CAP,180PF,±5%,C0G, 50V,SMD0402 | YES | Lead Free | Reach Not Affected | Jun-2016 | Active | CAP CER 180PF 50V C0G/NP0 0402 | GRM1555C1H181J A01D | 490-3231-1-ND |
| 37 | Ceramic Capacitor | GRM1555C1H821J A01D | 1 | C25 | Murata Electronics North America | CAP,820PF,±5%,C0G, 50V,SMD0402 | YES | Lead Free | Reach Not Affected | Jun-2016 | Active | CAP CER 820PF 50V C0G/NP0 0402 | GRM1555C1H821J A01D | 490-3242-1-ND |
| 38 | Ceramic Capacitor | GRM155R71H102K A01D | 6 | C50, C51, C52, C53, C54, C55 | Murata Electronics North America | CAP,1NF,±10%,X7R, 50V,SMD0402 | YES | Lead Free | Reach Not Affected | Jun-2016 | Active | CAP CER 1000PF 50V X7R 0402 | GRM155R71H102K A01D | 490-1303-1-ND |
| 39 | Ceramic Capacitor | GRM155R61A224K E19D | 1 | C83 | Murata Electronics North America | CAP,220NF,±10%,X5R, 10V,SMD0402 | YES | Lead Free | Reach Not Affected | Jun-2016 | Active | CAP CER 0.22UF 10V X5R 0402 | GRM155R61A224K E19D | 490-3910-1-ND |
| 40 | Ceramic Capacitor | GRM155R60J105K E19D | 5 | C6, C7, C19, C21,C22 | Murata Electronics North America | CAP,1UF,±10%,X5R,6.3 V,SMD0402 ?suffix J stand for 330mm reel ? | YES | Lead Free | Reach Not Affected | Jun-2016 | Active | CAP CER 1UF 6.3V X5R 0402 | GRM155R60J105K E19D | 490-1320-1-ND |

Table 9. LAUNCHXL-F28379D Bill of Materials (continued)

| Item # | Note | Part Number | Qty | REF Designator | Manufacturer (Digi-Key) | Description | ROHS (Digi-Key) | Lead Free Status | Reach Status (Digi-Key) | Reach Effective Date (Digi-Key) | Availability | Description (Digi-Key) | Manufacturer Part Number (Digi-Key) | Digi-Key Part Number (Digi-Key) |
|--------|-------------------|---------------------|-----|---|----------------------------------|--|-----------------|------------------|-------------------------|---------------------------------|--------------|--------------------------------|-------------------------------------|---------------------------------|
| 41 | Ceramic Capacitor | GRM155R60J225M E15D | 14 | C2, C27, C29, C42, C46, C47, C48, C49, C71, C72, C75, C76, C77, C78 | Murata Electronics North America | CAP,2.2UF,±20%,X5R, 6.3V,SMD0402 | YES | Lead Free | Reach Not Affected | Jun-2016 | Active | CAP CER 2.2µF 6.3V X5R 0402 | GRM155R60J225M E15D | 490-4519-1-ND |
| 42 | Ceramic Capacitor | GRM188R60J106M E47D | 5 | C68, C69, C70, C79, C81 | Murata Electronics North America | CAP,10UF,±20%,X5R, 6.3V,SMD0603 | YES | Lead Free | Reach Not Affected | Jun-2016 | Active | CAP CER 10µF 6.3V X5R 0603 | GRM188R60J106M E47D | 490-3896-1-ND |
| 43 | Ceramic Capacitor | GRM188R60J226M EA0D | 3 | C23,C38, C80 | Murata Electronics North America | CAP,22UF,±20%,X5R, 6.3V,SMD0603 | YES | Lead Free | Reach Not Affected | Jun-2016 | Active | CAP CER 22µF 6.3V X5R 0603 | GRM188R60J226M EA0D | 490-7611-1-ND |
| 44 | Ceramic Capacitor | GRM32DR71E106K A12L | 2 | C41, C44 | Murata Electronics North America | CAP,10UF,±10%,X7R, 25V,SMD1210 | YES | Lead Free | Reach Not Affected | Jun-2016 | Active | CAP CER 10µF 25V X7R 1210 | GRM32DR71E106K A12L | 490-1867-1-ND |
| 45 | Ceramic Capacitor | GRM155R61A104K A01D | 35 | C1, C5, C9, C12, C13, C14, C16, C24, C28, C30, C31, C32, C33, C34, C35, C36, C37, C39, C43, C56, C57, C58, C59, C60, C61, C62, C63, C64, C65, C66, C67, C73, C74,C84, C85 | Murata Electronics North America | CAP,100NF(0.1uf),±10% ,X5R,10V,SMD0402 | YES | Lead Free | Reach Not Affected | Jun-2016 | Active | CAP CER 0.1µF 10V X5R 0402 | GRM155R61A104K A01D | 490-1318-1-ND |
| 46 | Ceramic Capacitor | GRM32ER61E226K E15L | 1 | C45 | Murata Electronics North America | CAP,22UF,±10%,X5R, 25V,SMD1210 | YES | Lead Free | Reach Not Affected | Jun-2016 | Active | CAP CER 22µF 25V X5R 1210 | GRM32ER61E226K E15L | 490-3889-1-ND |
| 47 | Ceramic Capacitor | GRM155R60J475M E47D | 3 | C8, C10, C11 | Murata Electronics North America | CAP,4.7UF,±20%,X5R, 6.3V,SMD0402 fix PN add D?20151023? | YES | Lead Free | Reach Not Affected | Jun-2016 | Active | CAP CER 4.7µF 6.3V X5R 0402 | GRM155R60J475M E47D | 490-5915-1-ND |
| 48 | Ceramic Capacitor | GRM188R61A335K E15D | 1 | C15 | Murata Electronics North America | CAP,3.3uF,±10%,X5R, 10V,SMD0603 | YES | Lead Free | Reach Not Affected | Jun-2016 | Active | CAP CER 3.3µF 10V X5R 0603 | GRM188R61A335K E15D | 490-6411-1-ND |
| 49 | Ceramic Capacitor | GRM1555C1H360J A01D | 4 | C3,C4,C17,C18 | Murata Electronics North America | CAP,36pF,±5%,C0G,50V ,SMD0402 | YES | Lead Free | Reach Not Affected | Jun-2016 | Active | CAP CER 36PF 50V C0G/NP0 0402 | GRM1555C1H360J A01D | 490-5937-1-ND |
| 50 | Inductor | LQH3NPN1R0NJ0L | 1 | L8 | Murata Electronics North America | FIXED IND 1µH 1.62A 40 MΩ SMD,±30% | YES | Lead Free | Reach Not Affected | Jun-2016 | Active | FIXED IND 1µH 1.62A 40 MΩ SMD | LQH3NPN1R0NJ0L | 490-5342-1-ND |
| 51 | Inductor | CDRH2D18/HPNP-2R2NC | 1 | L7 | Sumida America Components Inc. | Power inductor,magnetic shielded,2.2µH,1.6A,0.06 Ω,3.0X3.0X1.8mm,SMD | YES | Lead Free | Reach Not Affected | Jun-2016 | Active | FIXED IND 2.2µH 1.9A 60 MΩ SMD | CDRH2D18/HPNP-2R2NC | 308-2295-2-ND |

Table 9. LAUNCHXL-F28379D Bill of Materials (continued)

| Item # | Note | Part Number | Qty | REF Designator | Manufacturer (Digi-Key) | Description | ROHS (Digi-Key) | Lead Free Status | Reach Status (Digi-Key) | Reach Effective Date (Digi-Key) | Availability | Description (Digi-Key) | Manufacturer Part Number (Digi-Key) | Digi-Key Part Number (Digi-Key) |
|--------|--------------|-----------------------|-----|------------------------------|----------------------------------|--|-----------------|------------------|-------------------------|---------------------------------|--------------|--------------------------------|-------------------------------------|---------------------------------|
| 52 | Inductor | CDRH3D16/HPNP-3R3NC | 1 | L6 | Sumida America Components Inc. | Power Inductor,Magnetic shielded,3.3μH,1.4A,0.085Ω,3.8X3.8X1.6mm,SMD | YES | Lead Free | Reach Not Affected | Jun-2016 | Non-Stock | FIXED IND 3.3μH 1.8A 85 MΩ SMD | CDRH3D16/HPNP-3R3NC | 308-1981-1-ND |
| 53 | Ferrite Bead | BLM15AG601SN1D | 2 | L1, L2 | Murata Electronics North America | Ferrite Bead,600Ω@100MHz,±25%,300mA,0.6Ω,SMD0402 | YES | Lead Free | Reach Not Affected | Jun-2016 | Active | FERRITE BEAD 600 Ω 0402 1LN | BLM15AG601SN1D | 490-1006-1-ND |
| 54 | Ferrite Bead | BLM15PD600SN1D | 2 | L3, L4 | Murata Electronics North America | Ferrite Bead,60Ω@100MHz,±25%,1700mA,0.06Ω,SMD0402 | YES | Lead Free | Reach Not Affected | Jun-2016 | Active | FERRITE BEAD 60 Ω 0402 1LN | BLM15PD600SN1D | 490-5201-1-ND |
| 55 | Ferrite Bead | BKP1005EM221-T | 2 | L5, L11 | Taiyo Yuden | FERRITE BEAD 220 Ω 0402,±25% | YES | Lead Free | Reach Not Affected | Jun-2016 | Active | FERRITE BEAD 220 Ω 0402 1LN | BKP1005EM221-T | 587-3290-1-ND |
| 56 | LED | 150080VS75000 | 2 | D1, D4 | Würth Electronics Inc. | LED, Bright GREEN , 570nm,20mA,SMD,0805 | YES | Lead Free | Reach Not Affected | Jan-2017 | Active | LED GREEN CLEAR 0805 SMD | 150080VS75000 | 732-4986-1-ND |
| 57 | LED | 150080BS75000 | 2 | D7, D10 | Würth Electronics Inc. | LED, BLUE ,470NM, 20mA,SMD,0805 | YES | Lead Free | Reach Not Affected | Jan-2017 | Active | LED BLUE CLEAR 0805 SMD | 150080BS75000 | 732-4982-1-ND |
| 58 | LED | 150080SS75000 | 2 | D8, D9 | Würth Electronics Inc. | LED, SUPPER RED ,630NM,20mA, SMD,0805 | YES | Lead Free | Reach Not Affected | Jan-2017 | Active | LED RED CLEAR 0805 SMD | 150080SS75000 | 732-4985-1-ND |
| 59 | Diode | 1N5819HW-7-F | 1 | D3 | Diodes Incorporated | Diode,Schottky Diode,1N5819HW-7-F,40V,1A,SOD-123,SMD,-65-125,TR | YES | Lead Free | Reach Not Affected | Jan-2017 | Active | DIODE SCHOTTKY 40V 1A SOD123 | 1N5819HW-7-F | 1N5819HW-FDICT-ND |
| 60 | Polyswitch | MF-MSMF050-2 | 1 | F1 | Bourns Inc. | PTC RESETTABLE .50A 15V 1812 | YES | Lead Free | Reach Not Affected | Jan-2017 | Active | PTC RESETTABLE .50A 15V 1812 | MF-MSMF050-2 | MF-MSMF050-2CT-ND |
| 61 | Crystal | ABLS2-12.000MHZ-D4Y-T | 1 | Q3 | Abracon LLC | Crystal 12MHz ±30ppm (Tol) ±30ppm (Stability) 18pF FUND 50Ω 2-Pin HC-49/US SMD T/R | YES | Lead Free | REACH AFFECTED | Jan-2017 | Active | CRYSTAL 12.000MHZ 18PF SMD | ABLS2-12.000MHZ-D4Y-T | 535-9869-1-ND |
| 62 | Crystal | ATS100B-E | 1 | Q1 | CTS-Frequency Controls | Crystal 10.0000MHz 30ppm 18pF 60 Ω -40°C - 85°C Through Hole HC49/US | YES | Lead Free | Reach Not Affected | Jan-2017 | Active | CRYSTAL 10.0000MHZ 18PF T/H | ATS100B-E | CTX919-ND |
| 63 | Pin Header | P6E02A-602530-B1 | 6 | JP1, JP2, JP3, JP4, JP5, JP6 | | Connector,Pin Header,Straight,Male,1x 2Pin,2.54MM pitch,6.00,3.00,Gold Flash 1u, black,DIP,alt_code:15071705 | | | | | | | | |
| 64 | Pin Header | P6E03A-602530-B1 | 3 | J10,J12,J16 | | Connector,Pin Header,Straight,Male,1x 3Pin,2.54MM pitch,6.00,3.00,Gold Flash 1u, black,DIP,alt_code:15071706 | | | | | | | | |

Table 9. LAUNCHXL-F28379D Bill of Materials (continued)

| Item # | Note | Part Number | Qty | REF Designator | Manufacturer (Digi-Key) | Description | ROHS (Digi-Key) | Lead Free Status | Reach Status (Digi-Key) | Reach Effective Date (Digi-Key) | Availability | Description (Digi-Key) | Manufacturer Part Number (Digi-Key) | Digi-Key Part Number (Digi-Key) |
|--------|----------------|----------------------|-----|---------------------------------|-------------------------------|--|-----------------|------------------|-------------------------|---------------------------------|--------------|----------------------------------|-------------------------------------|---------------------------------|
| 65 | Pin Header | P101-1*05SGF-116A-NX | 2 | QEP_A, QEP_B | | Connector,Pin Header,Straight,Male,1x 5Pin,2.54MM pitch,6.06,3.00,Gold Flash 1u, black,DIP | | | | | | | | |
| 66 | Pin Header | P101-2*04SGF-116A-NX | 1 | J21 | | Connector,Pin Header,Straight,Male,2x 4Pin,2.54MM pitch,6.06,3.00,Gold Flash 1u, black,DIP | | | | | | | | |
| 67 | Pin Socket | CRD-081413-A-G | 4 | (J1,J3),(J2?J4),(J5?J7),(J6?J8) | | Connector,Pin Socket,Straight,Female,2 x10Pin,2.54MM pitch,8.51,9.91,Gold Flash 10u, black,DIP upgrade MPN. old part->CRD-081413-G-A | | | | | | | | |
| 68 | USB Connector | 897-43-005-00-100001 | 1 | CON1 | Mill-Max Manufacturing Corp. | Connector,MiniUSB B port,5 position,Right Angle,Gold flash 30u,black,SMD | YES | Lead Free | Reach Not Affected | Jan-2017 | Active | CONN RECEPT MINI-USB TYPE B SMT | 897-43-005-00-100001 | ED90341CT-ND |
| 69 | BTB Connector | DF40C-60DP-0.4V(51) | 1 | J9 | Hirose Electric Co Ltd | CONN HDR 60POS 0.4MM SMD GOLD TR | YES | Lead Free | Reach Not Affected | Dec-2015 | Active | CONN HDR 60POS 0.4MM SMD GOLD | DF40C-60DP-0.4V(51) | H11628CT-ND |
| 70 | Shunt | MJ501-EOGF-B-K | 5 | JP1,JP2,J P3,JP4,J P5 | | Connector,Shunt,open type 2Pin,2.54MM Pitch,6MM Height,Gold Flash 1u,black,Bulk | | | | | | | | |
| 71 | Tactile Switch | B3F-3152 | 1 | S3 | Omron Electronics Inc-EMC Div | SWITCH TACTILE SPST-NO 0.05A 24V | YES | Lead Free | Reach Not Affected | Dec-2015 | Active | SWITCH TACTILE SPST-NO 0.05A 24V | B3F-3152 | SW410-ND |
| 72 | DIP Switch | 219-3MST | 1 | S1 | CTS Electrocomponents | Switch, DIP Switches,3 Position,2.54MM Pitch,black housing,white plunger,SMD | YES | Lead Free | Reach Not Affected | Jun-2016 | Active | SWITCH SLIDE DIP SPST 100MA 20V | 219-3MST | CT2193MST-ND |

7 References

The following documents describe the C2000 devices. Copies of these documents are available on the Internet at <http://www.ti.com/c2000> and www.ti.com/c2000-launchpad, or click on the links below:

1. *TMS320F2837xD Dual-Core Delfino™ Microcontrollers Data Manual* ([SPRS880](#))
2. *TMS320F28379D, TMS320F28377D, TMS320F28376D, TMS320F28375D, TMS320F28374D Delfino Microcontrollers Silicon Errata* ([SPRZ412](#))
3. *TMS320F2837xD Dual-Core Delfino Microcontrollers Technical Reference Guide* ([SPRUHM8](#))
4. *TMS320C28x Extended Instruction Sets Technical Reference Manual* ([SPRUHS1](#))
5. *TMS320C28x Instruction Set Simulator Technical Overview* ([SPRU608](#))
6. *TMS320C28x Optimizing C/C++ Compiler v6.1 User's Guide* ([SPRU514](#))
7. *TMS320C28x Assembly Language Tools v6.1 User's Guide* ([SPRU513](#))

8 Frequently Asked Questions (FAQ)

1. Can other programming and debug tools (such as an XDS510 debug probe) be used with the C2000 LaunchPad?

While a user could potentially connect an external debug probe to the F28379D device present on the LaunchPad, it would require some rework of the board. It is recommended that users who want to use an external debug probe, purchase a controlCard and docking station that includes an external JTAG connector.

2. What versions of Code Composer Studio can be used to develop software for the C2000 LaunchPad?

It is highly recommend that novice users develop applications with at least Code Composer Studio v6. The drivers, examples, and other associated software are tailored to make the user experience as smooth as possible in Code Composer Studio v6.

3. Why can't I connect to the LaunchPad in Code Composer Studio?

There are a number of things that could cause this and they all have an easy fix.

- Is S1 switch 3 in the down position?

This is the TRST pin that enables and disables JTAG functionality on the chip. This switch must be in the up position for the debug probe to be able to connect.

- Are both power LEDs lit?

The board has two power domains because of the isolated JTAG interface. For low-voltage application development, JTAG isolation is not needed and the power domains can be combined to allow for convenience (that is, the board can be powered completely through the USB). Ensure that jumpers are placed on the posts of JP1 and JP2.

- Are drivers correctly installed for the XDS100v2 present on the LaunchPad?

Right click on *My Computer* and select properties. Navigate to the *Hardware* tab in the dialog box and open the device manager. Scroll to the bottom of the list and expand the *USB Serial Bus controllers* item. Are there two entries for *TI XDS100 Channel A/B*? If not, try unplugging and replugging in the board. Does Windows give you any messages in the system tray? In Device Manger, do either of the entries have a yellow exclamation mark over their icon? If so, try reinstalling the drivers.

4. Why is the serial connection not working?

- Are you using the correct COM port?

Right click on *My Computer* and select properties. Navigate to the *Hardware* tab in the dialog box and open the device manager. Scroll to *Ports (COM & LPT)* and expand this entry. Is there a USB Serial Port listed? If so, read the COM number to the right of the entry; this is the COM number you should be using.

- Are you using the correct baud rate?

Most, if not all, of the examples are configured for a baud rate of 115200 when the CPU is running at 200 MHz. If you have changed the PLL settings or written your own application you may have to recalculate the baud rate for your specific application. For information on how to do this, see the [TMS320F2837xD Delfino Microcontrollers Technical Reference Guide](#).

5. Why is my program operating at half the frequency of what I expected?

- By default many of the C2000Ware examples are configured to operate on the TMDSCNCD28379D which has a different clocking circuit, where the external clock is 20 MHz instead of 10 MHz as found on this EVM.
- A compiler switch was added to various functions to allow a user to change the clocking configuration based on the status of a predefined symbol.
- To ensure the PLL is correctly configured for the LAUNCHXL-F28379D, Add "_LAUNCHXL_F28379D" to the predefined symbols list.
- Access the Predefined symbols list by accessing the Project Properties, Navigating to Build » C2000 Compiler » Advanced Options » Predefined Symbols. [Figure 22](#) shows the Project Properties selection tree and the symbol added to the pre-define list.

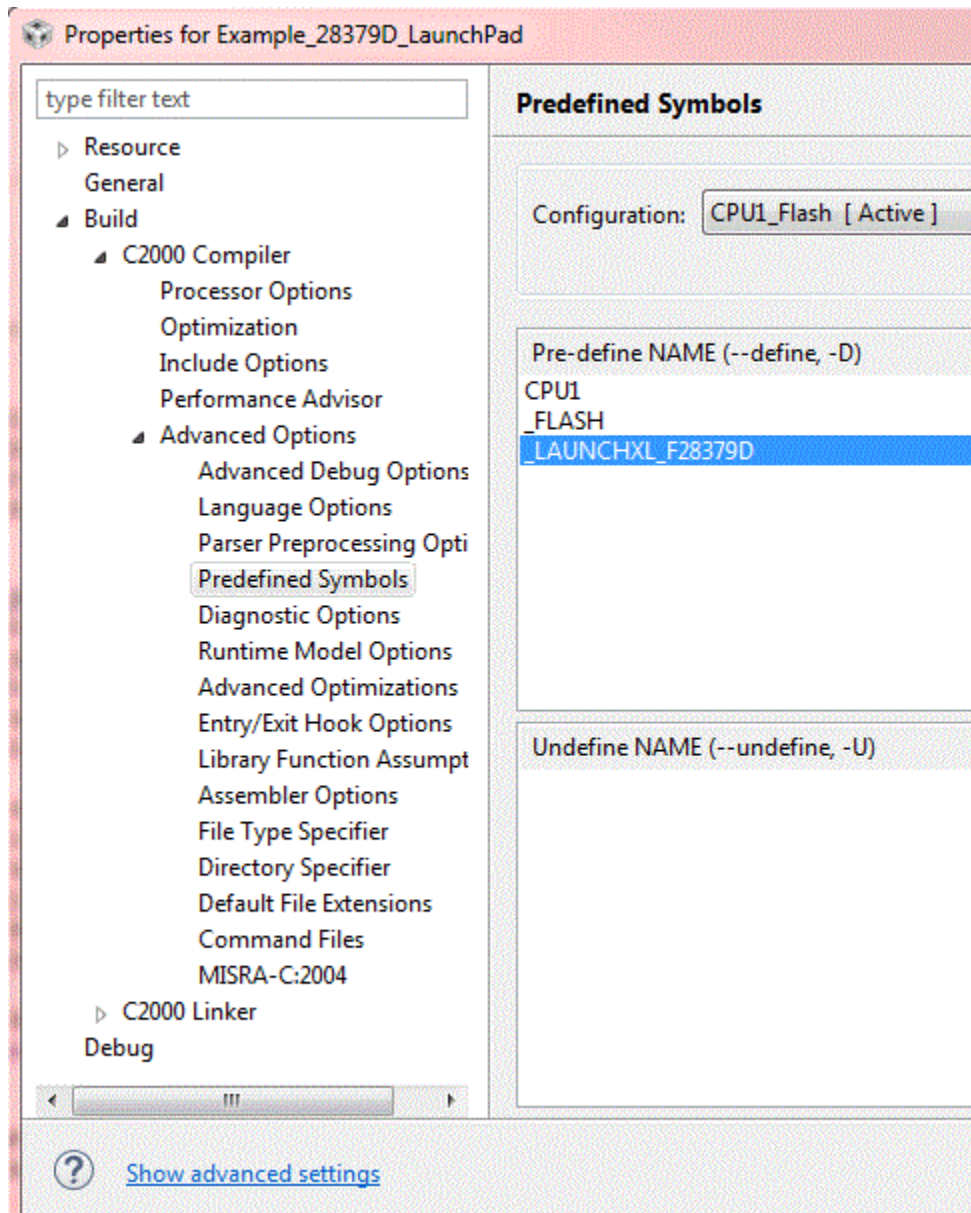

Figure 22.

Revision History

NOTE: Page numbers for previous revisions may differ from page numbers in the current version.

| Changes from B Revision (June 2018) to C Revision | Page |
|--|-------------|
| • Global Replacement of "emulator" with "debug probe"..... | 1 |
| • Added list of known issues for all revisions of the EVM to Section 2.1 | 3 |
| • Added note about lack of Boot-to-SCI options on this board in Section 2.1 | 3 |
| • Added Section 4.4 | 5 |
| • Added an FAQ in Section 8 for code executing at half of the expected frequency. | 27 |

IMPORTANT NOTICE AND DISCLAIMER

TI PROVIDES TECHNICAL AND RELIABILITY DATA (INCLUDING DATASHEETS), DESIGN RESOURCES (INCLUDING REFERENCE DESIGNS), APPLICATION OR OTHER DESIGN ADVICE, WEB TOOLS, SAFETY INFORMATION, AND OTHER RESOURCES "AS IS" AND WITH ALL FAULTS, AND DISCLAIMS ALL WARRANTIES, EXPRESS AND IMPLIED, INCLUDING WITHOUT LIMITATION ANY IMPLIED WARRANTIES OF MERCHANTABILITY, FITNESS FOR A PARTICULAR PURPOSE OR NON-INFRINGEMENT OF THIRD PARTY INTELLECTUAL PROPERTY RIGHTS.

These resources are intended for skilled developers designing with TI products. You are solely responsible for (1) selecting the appropriate TI products for your application, (2) designing, validating and testing your application, and (3) ensuring your application meets applicable standards, and any other safety, security, or other requirements. These resources are subject to change without notice. TI grants you permission to use these resources only for development of an application that uses the TI products described in the resource. Other reproduction and display of these resources is prohibited. No license is granted to any other TI intellectual property right or to any third party intellectual property right. TI disclaims responsibility for, and you will fully indemnify TI and its representatives against, any claims, damages, costs, losses, and liabilities arising out of your use of these resources.

TI's products are provided subject to TI's Terms of Sale (www.ti.com/legal/termsofsale.html) or other applicable terms available either on ti.com or provided in conjunction with such TI products. TI's provision of these resources does not expand or otherwise alter TI's applicable warranties or warranty disclaimers for TI products.

Mailing Address: Texas Instruments, Post Office Box 655303, Dallas, Texas 75265
Copyright © 2019, Texas Instruments Incorporated

Looking for pricing, stock, or lifecycle information?

Click below to explore more details on WIN SOURCE:

 [View LAUNCHXL-F28379D on WIN SOURCE](#)

 [Texas Instruments](#) Information

Optimize Your Supply Chain with WIN SOURCE Solutions

-  Global Sourcing Solution
-  Obsolete Management
-  Cost Control Management
-  Shortage Management
-  Alternative Solution
-  Excess Inventory Management