



**THE DATASHEET OF  
IS31FL3196A-QFLS2-TR**



# IS31FL3196A

## 6-CHANNEL LIGHT EFFECT LED DRIVER

August 2020

### GENERAL DESCRIPTION

IS31FL3196A is a 6-channel light effect LED driver which features two-dimensional auto breathing mode and an audio modulated display mode. It has One Shot Programming mode and PWM Control mode for RGB lighting effects. The maximum output current can be adjusted in 8 levels (5mA~40mA).

In PWM Control mode, the PWM duty cycle of each output can be independently programmed and controlled in 256 steps to simplify color mixing. In One Shot Programming mode, the timing characteristics for output current - current rising, holding, falling and off time, can be adjusted individually so that each output can independently maintain a pre-established pattern achieving mixing color breathing or a single color breathing without requiring any additional interface activity, thus saving valuable system resources.

The IS31FL3196A includes an audio modulated display mode, wherein the brightness of LED can be modulated by audio signal. There is a cascade pin for the synchronization of two chips.

IS31FL3196A is available in QFN-20 (3mm × 3mm). It operates from 2.7V to 5.5V over the temperature range of -40°C to +85°C.

### FEATURES

- 2.7V to 5.5V supply voltage
- I2C interface
- Rising edge of SDB reset I2C module
- Two groups RGB, single color LED breathing system-free pre-established pattern
- 6 independently controlled automatic and semiautomatic breathing system-free pre-established pattern
- 6 independently controlled outputs of 256 PWM steps
- 8 levels programmable output current
- Audio mode with AGC function
- Cascade for the synchronization of chips
- Over-temperature protection
- QFN-20 (3mm × 3mm) package

### APPLICATIONS

- Mobile phones and other hand-held devices for LED display
- LED in home appliances

### TYPICAL APPLICATION CIRCUIT

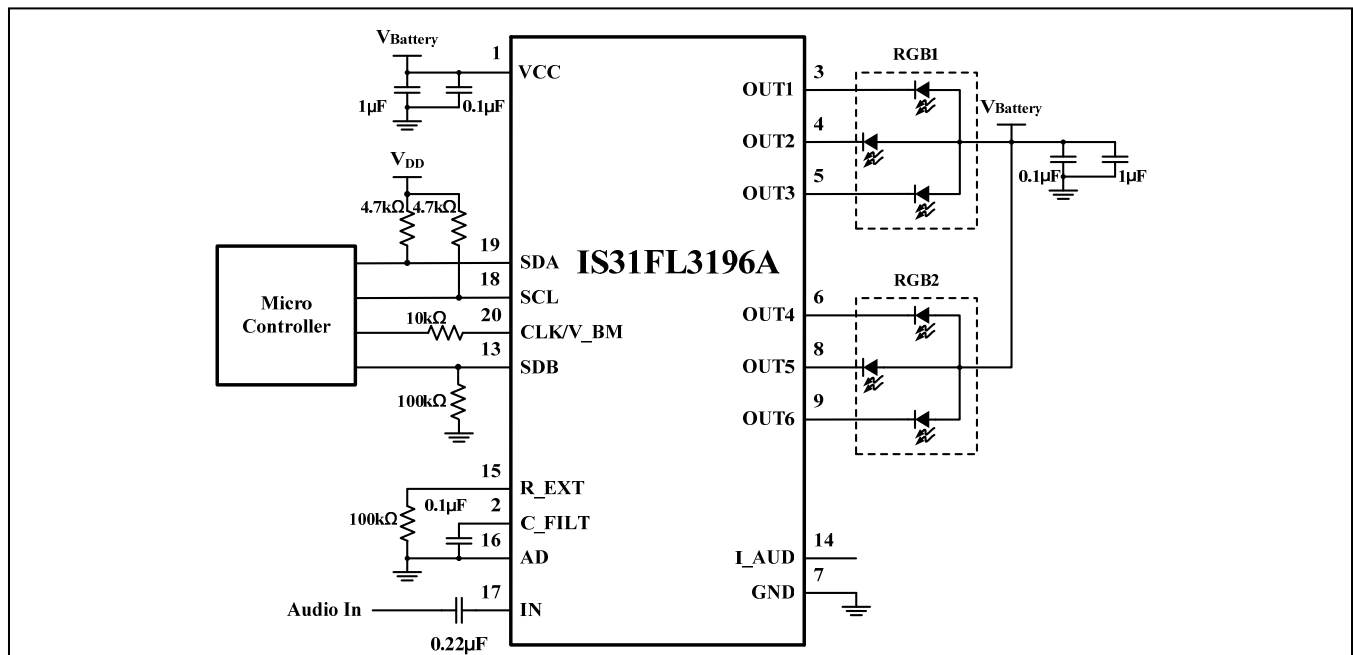
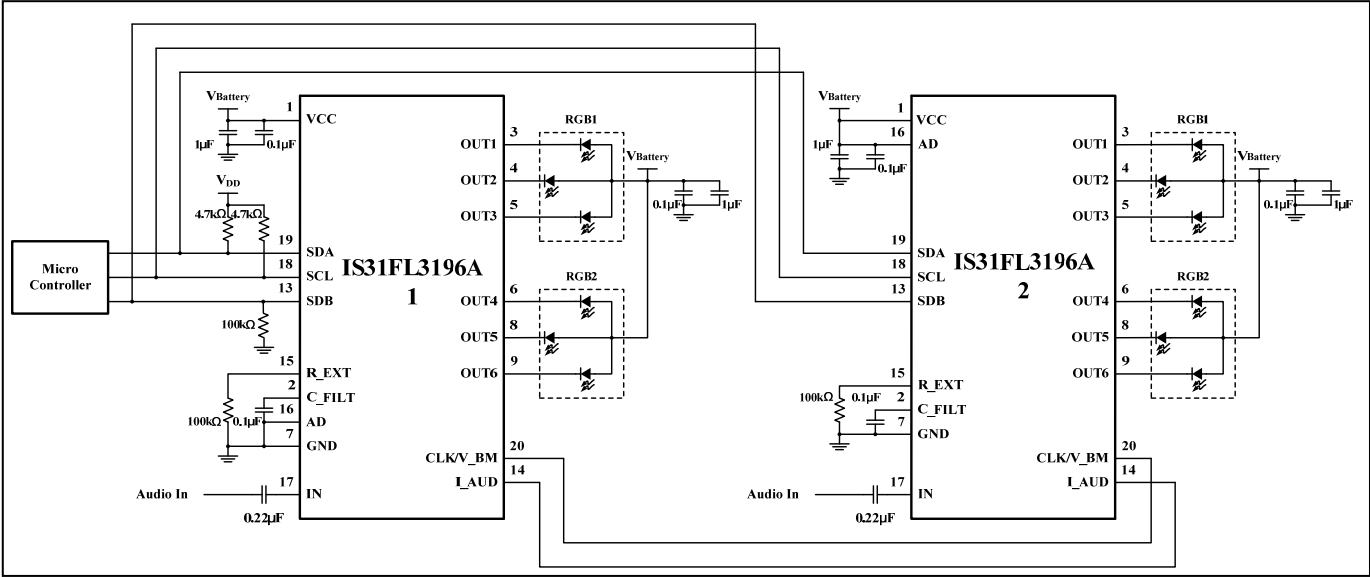

Figure 1 Typical Application Circuit

**Note 1:** The IC should be placed far away from the mobile antenna in order to prevent the EMI.

# IS31FL3196A



**Figure 2** Typical Application Circuit (Cascade Mode)

# IS31FL3196A

## PIN CONFIGURATION

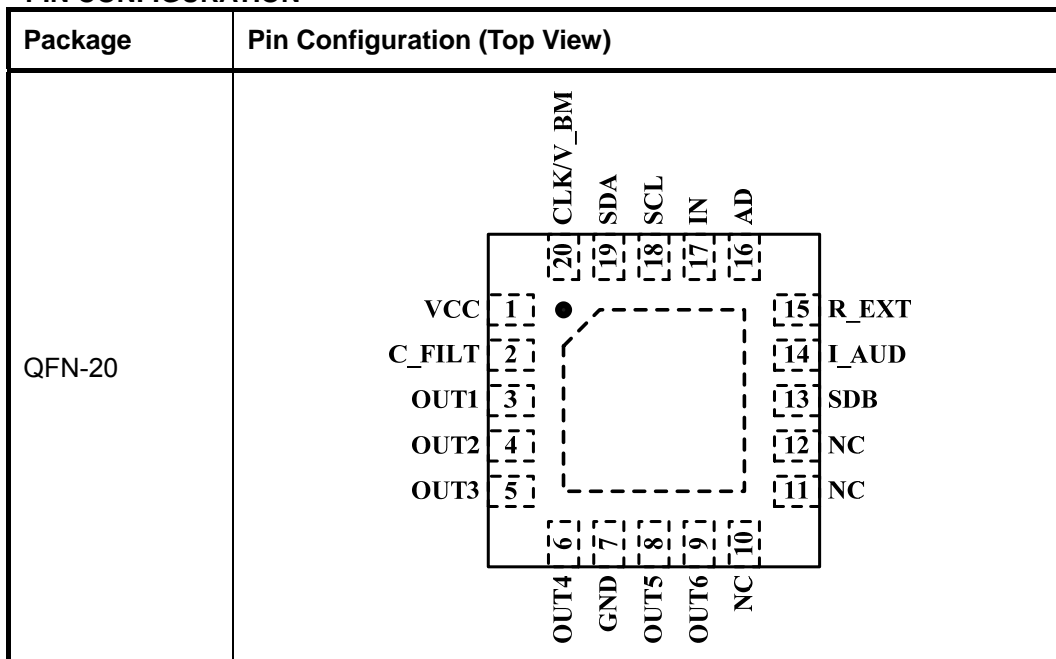

## PIN DESCRIPTION

No.	Pin	Description
1	VCC	Power supply.
2	C_FILT	Filter capacitor for audio control.
3~6	OUT1~OUT4	Current source outputs.
7	GND	Ground.
8, 9	OUT5~OUT6	Current source outputs.
10~12	NC	No connection.
13	SDB	Shutdown the chip when pulled to low.
14	I_AUD	Audio current input or output for cascade.
15	R_EXT	Input terminal used to connect an external resistor. The value must be about 100kΩ.
16	AD	I2C address setting.
17	IN	Audio input.
18	SCL	I2C serial clock.
19	SDA	I2C serial data.
20	CLK/V_BM	CLK input or output for cascade. When breathing mark function enable, this pin is V_BM pin.
	Thermal Pad	Need to connect to GND.

# IS31FL3196A

## ORDERING INFORMATION

Industrial Range: -40°C to +85°C

Order Part No.	Package	QTY/Reel
IS31FL3196A-QFLS2-TR	QFN-20, Lead-free	2500

Copyright © 2020 Lumissil Microsystems. All rights reserved. Lumissil Microsystems reserves the right to make changes to this specification and its products at any time without notice. Lumissil Microsystems assumes no liability arising out of the application or use of any information, products or services described herein. Customers are advised to obtain the latest version of this device specification before relying on any published information and before placing orders for products.

Lumissil Microsystems does not recommend the use of any of its products in life support applications where the failure or malfunction of the product can reasonably be expected to cause failure of the life support system or to significantly affect its safety or effectiveness. Products are not authorized for use in such applications unless Lumissil Microsystems receives written assurance to its satisfaction, that:

- a.) the risk of injury or damage has been minimized;
- b.) the user assume all such risks; and
- c.) potential liability of Lumissil Microsystems is adequately protected under the circumstances

# IS31FL3196A

## ABSOLUTE MAXIMUM RATINGS

Supply voltage, $V_{CC}$	-0.3V ~ +6.0V
Voltage at any OUTx pins	-0.3V ~ +6.0V
Voltage at any input pins	-0.3V ~ $V_{CC}+0.3V$
GND terminal current	400mA
Maximum junction temperature, $T_{JMAX}$	+150°C
Storage temperature range, $T_{STG}$	-65°C ~ +150°C
Operating temperature range, $T_A=T_J$	-40°C ~ +85°C
Package thermal resistance, junction to ambient (4 layer standard test PCB based on JEDEC standard), $\theta_{JA}$	58.1°C/W
ESD (HBM)	±2kV
ESD (CDM)	±1kV

**Note 2:** Stresses beyond those listed under “Absolute Maximum Ratings” may cause permanent damage to the device. These are stress ratings only and functional operation of the device at these or any other condition beyond those indicated in the operational sections of the specifications is not implied. Exposure to absolute maximum rating conditions for extended periods may affect device reliability.

## ELECTRICAL CHARACTERISTICS

$T_A = 25^\circ\text{C}$ ,  $V_{CC} = 2.7V \sim 5.5V$ , unless otherwise noted. Typical value are  $T_A = 25^\circ\text{C}$ ,  $V_{CC} = 5V$ .

Symbol	Parameter	Condition	Min.	Typ.	Max.	Unit
$V_{CC}$	Supply voltage		2.7		5.5	V
$I_{CC}$	Quiescent power supply current	$V_{SDB} = V_{CC}$		3		mA
$I_{SD}$	Shutdown current	$V_{SDB} = 0V$		1		μA
		$V_{SDB} = V_{CC}$ , software shutdown		2		
$I_{OUT}$	Output current	PWM Control Mode, $V_{DS} = 0.4V$ PWM Register(07h~0Ch) = 0xFF		20 (Note 3)		mA
		Audio Mode, Gain = 12dB $V_{IN} = 0.8V_{P-P}$ , 1kHz square wave		18 (Note 3)		
$V_{HR}$	Current sink headroom voltage	$I_{OUT} = 20mA$		400		mV

### Logic Electrical Characteristics (SDA, SCL, SDB, AD)

$V_{IL}$	Logic “0” input voltage	$V_{CC} = 2.7V \sim 5.5V$			0.4	V
$V_{IH}$	Logic “1” input voltage	$V_{CC} = 2.7V \sim 5.5V$	1.4			V
$I_{IL}$	Logic “0” input current	SSD= “0”, $V_{INPUT} = 0V$		5 (Note 4)		nA
$I_{IH}$	Logic “1” input current	SSD= “0”, $V_{INPUT} = V_{CC}$		5 (Note 4)		nA

# IS31FL3196A

## DIGITAL INPUT SWITCHING CHARACTERISTICS (Note 5)

Symbol	Parameter	Condition	Standard Mode			Fast Mode			Unit
			Min.	Typ.	Max.	Min.	Typ.	Max.	
$f_{SCL}$	Serial-Clock frequency				100			400	kHz
$t_{BUF}$	Bus free time between a STOP and a START condition		4.7			1.3			$\mu$ s
$t_{HD, STA}$	Hold time (repeated) START condition		4.0			0.6			$\mu$ s
$t_{SU, STA}$	Repeated START condition setup time		4.7			0.6			$\mu$ s
$t_{SU, STO}$	STOP condition setup time		4.0			0.6			$\mu$ s
$t_{HD, DAT}$	Data hold time (Note 6)		0		3.45	0		0.9	$\mu$ s
$t_{SU, DAT}$	Data setup time (Note 7)		250			100			ns
$t_{LOW}$	SCL clock low period		4.7			1.3			$\mu$ s
$t_{HIGH}$	SCL clock high period		4.0			0.7			$\mu$ s
$t_R$	Rise time of both SDA and SCL signals, receiving (Note 8)				1000		$20+0.1C_b$	300	ns
$t_F$	Fall time of both SDA and SCL signals, receiving (Note 8)				300		$20+0.1C_b$	300	ns

**Note 3:** The average current of each channel is  $I_{OUT}$ .

**Note 4:** All LEDs are on.

**Note 5:** Guaranteed by design.

**Note 6:** The minimum  $t_{HD, DAT}$  measured start from  $V_{IL(max)}$  of SCL signal. The maximum  $t_{HD, DAT}$  has only to be met if the device does not stretch the LOW period ( $t_{LOW}$ ) of the SCL signal.  $V_{IL(max)}$

**Note 7:** A Fast-mode I2C-bus device can be used in a Standard-mode I2C-bus system, but the requirement  $t_{SU, DAT} \geq 250$  ns must then be met. This will automatically be the case if the device does not stretch the LOW period of the SCL signal. If such a device does stretch the LOW period of the SCL signal, it must output the next data bit to the SDA line  $t_R \max + t_{SU, DAT} = 1000 + 250 = 1250$ ns (according to the Standard-mode I2C-bus specification) before the SCL line is released.

**Note 8:**  $C_b$  = total capacitance of one bus line in pF.  $I_{SINK} \leq 6$ mA.  $t_R$  and  $t_F$  measured between  $0.3 \times V_{CC}$  and  $0.7 \times V_{CC}$ .

# IS31FL3196A

## DETAILED DESCRIPTION

### I2C INTERFACE

The IS31FL3196A uses a serial bus, which conforms to the I2C protocol, to control the chip's functions with two wires: SCL and SDA. The IS31FL3196A has a 7-bit slave address (A7:A1), followed by the R/W bit, A0. Since IS31FL3196A only supports write operations, A0 must always be "0". The value of bits A1 and A2 are decided by the connection of the AD pin.

The complete slave address is:

**Table 1 Slave Address (Write Only):**

Bit	A7:A3	A2:A1	A0
Value	11001	AD	0

- AD connected to GND, AD = 00;
- AD connected to VCC, AD = 11;
- AD connected to SCL, AD = 01;
- AD connected to SDA, AD = 10;

The SCL line is uni-directional. The SDA line is bi-directional (open-collector) with a pull-up resistor (typically 4.7kΩ). The maximum clock frequency specified by the I2C standard is 400kHz. In this discussion, the master is the microcontroller and the slave is the IS31FL3196A.

The timing diagram for the I2C is shown in Figure 3. The SDA is latched in on the stable high level of the SCL. When there is no interface activity, the SDA line should be held high.

The "START" signal is generated by lowering the SDA signal while the SCL signal is high. The start signal will alert all devices attached to the I2C bus to check the incoming address against their own chip address.

The 8-bit chip address is sent next, most significant bit first. Each address bit must be stable while the SCL level is high.

After the last bit of the chip address is sent, the master checks for the IS31FL3196A's acknowledge. The master releases the SDA line high (through a pull-up resistor). Then the master sends an SCL pulse. If the IS31FL3196A has received the address correctly, then it holds the SDA line low during the SCL pulse. If the SDA line is not low, then the master should send a "STOP" signal (discussed later) and abort the transfer.

Following acknowledge of IS31FL3196A, the register address byte is sent, most significant bit first. IS31FL3196A must generate another acknowledge indicating that the register address has been received.

Then 8-bit of data byte are sent next, most significant bit first. Each data bit should be valid while the SCL level is stable high. After the data byte is sent, the IS31FL3196A must generate another acknowledge to indicate that the data was received.

The "STOP" signal ends the transfer. To signal "STOP", the SDA signal goes high while the SCL signal is high.

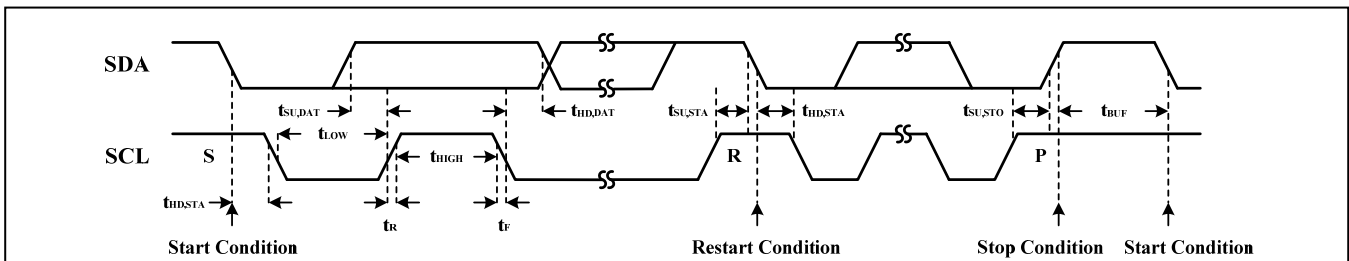

**Figure 3** Interface Timing

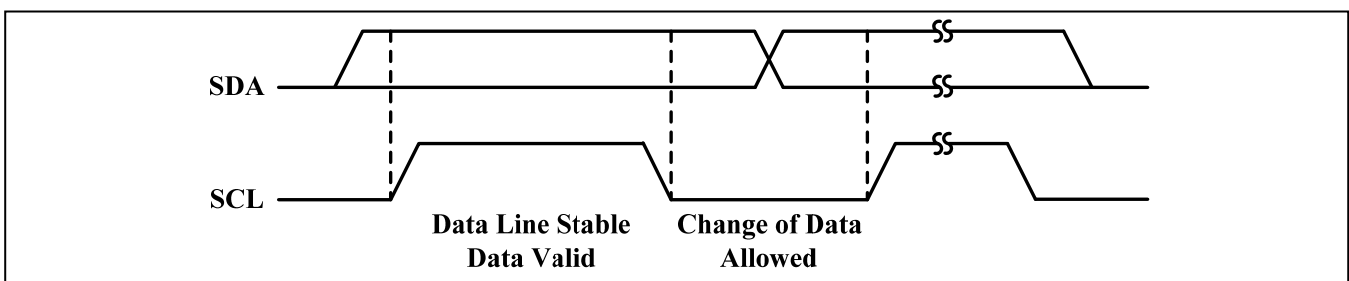

**Figure 4** Bit Transfer

# IS31FL3196A

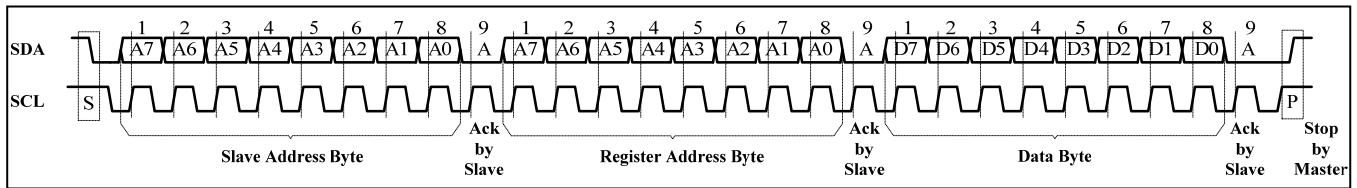

Figure 5 Writing to IS31FL3196A

## REGISTERS DEFINITIONS

Table 2 Register Function

Address	Name	Function	R/W	Table	Default
00h	Shutdown Register	Set software shutdown mode	W	3	0000 0000
01h	LED Control Register	OUT1~ OUT6 enable bit		4	0111 0111
03h	Configuration Register 1	Set operation mode		5	0000 0000
04h	Configuration Register 2	Set output current and audio input gain		6	
05h	Ramping Mode Register	Set the ramping function mode		7	
06h	Breathing Mark Register	Set the breathing mark function		8	
07h ~ 0Ch	PWM Register	6 channels PWM duty cycle data registers		9	
10h	Data Update Register	Load PWM Registers and LED Control Registers' data		-	xxxx xxxx
11h ~ 16h	T0 Register	Set the T0 time		10	0000 0000
1Ah ~ 1Bh	T1~T3 Register	Set the T1~T3 time		11	
1Dh ~ 22h	T4 Register	Set the T4 time		12	
26h	Time Update Register	Load time registers' data		-	xxxx xxxx
FFh	Reset Register	Reset all registers to default value		-	

Table 3 00h Shutdown Register

Bit	D7:D1	D0
Name	-	SSD
Default	0000000	0

The Shutdown Register sets software shutdown mode of IS31FL3196A.

<b>SSD</b>	Software Shutdown Enable
0	Software shutdown mode
1	Normal operation

Table 4 01h LED Control Register (OUT1~OUT6)

Bit	D7	D6:D4	D3	D2:D0
Name	-	OUT6:OUT4	-	OUT3:OUT1
Default	0	111	0	111

The LED Control Registers store the on or off state of each channel LED.

<b>OUTx</b>	LED State
0	LED off
1	LED on

# IS31FL3196A

**Table 5 03h Configuration Register 1**

Bit	D7:D6	D5:D4	D3	D2	D1	D0
Name	-	RGB2:1	-	AE	AGCE	AGCM
Default	00	00	0	0	0	0

The Configuration Register 1 sets operation mode.

**RGBx** RGB Mode Selection  
 0 PWM Control Mode  
 1 One Shot Programming Mode

**AE** Audio Modulate Enable  
 0 Disable  
 1 Enable

**AGCE** AGC Function Enable  
 0 Enable  
 1 Disable

**AGCM** AGC Mode Selection  
 0 Mode1 (Fast Modulation)  
 1 Mode2 (Slow Modulation)

**Table 6 04h Configuration Register 2**

Bit	D7	D6:D4	D3	D2:D0
Name	CM	CS	-	AGS
Default	0	000	0	000

The Configuration Register 2 stores the intensity control settings for all of the LEDs and the control mode.

**CM** Control Mode  
 0 Master  
 1 Slave

**CS** Current Setting  
 000 20mA  
 001 15mA  
 010 10mA  
 011 5mA  
 100 40mA  
 101 35mA  
 110 30mA  
 111 25mA

**AGS** Audio Gain Selection  
 000 Gain= 0dB  
 001 Gain= 3dB  
 010 Gain= 6dB  
 011 Gain= 9dB  
 100 Gain= 12dB  
 101 Gain= 15dB  
 110 Gain= 18dB  
 111 Gain= 21dB

**Table 7 05h Ramping Mode Register**

Bit	D7:D6	D5:D4	D3:D2	D1:D0
Name	-	RM(RGB2:1)	-	HT(RGB2:1)
Default	00	00	00	00

The Ramping Mode Register sets the ramping function.

**RM** Ramping Mode Enable  
 0 Disable  
 1 Enable

**HT** Hold Time Selection  
 0 Breathing Hold on T2  
 1 Breathing Hold on T4

**Table 8 06h Breathing Mark Register**

Bit	D7:D5	D4	D3	D2:D0
Name	-	BME	-	CSS
Default	000	0	0	000

The Breathing Mark Register sets the breathing mark function (Detail information refers to Page 12).

**BME** Breathing Mark Enable  
 0 Disable  
 1 Enable

**CSS** Channel Selection  
 000 OUT1  
 001 OUT2  
 010 OUT3  
 011 OUT4  
 100 OUT5  
 101 OUT6  
 Others Unavailable

# IS31FL3196A

**Table 9 07h~0Ch PWM Register (OUT1~OUT6)**

Bit	D7:D0
Name	PWM
Default	0000 0000

The PWM Registers can modulate RGB light with 256 different items.

The value of PWM Registers decide the average output current of OUT1~OUT6. The average output current may be computed using the Formula (1):

$$I_{OUT} = \frac{I_{MAX}}{256} \cdot \sum_{n=0}^7 D[n] \cdot 2^n \quad (1)$$

Where “n” indicates the bit location in the respective PWM register.

For example: D7:D0 = 10110101,

$$I_{OUT} = I_{MAX} (2^0 + 2^2 + 2^4 + 2^5 + 2^7) / 256$$

$I_{MAX}$  is set by Configuration Register2 (04h).

## 10h Data Update Register

The data sent to the PWM Registers and the LED Control Registers will be stored in temporary registers. A write operation of “0000 0000” value to the Data Update Register is required to update the registers (01h, 07h~0Ch).

**Table 10 11h~16h T0 Register (OUT1~OUT6)**

Bit	D7:D6	D5:D4	D3:D0
Name	-	B	A
Default	00	00	0000

The T0 Registers set the T0 time in One Shot Programming Mode.

$$T0 = \tau \times A \times 2^B$$

A = 0~15, B = 0~3 and  $\tau = 260\text{ms}$  (Typ.)

For example, the max T0 is  $260\text{ms} \times 15 \times 2^3 = 31.2\text{s}$

**Table 11 1Ah~1Bh T1~T3 Register (RGB1~RGB2)**

Bit	D7	D6:D4	D3	D2:D0
Name	DT	B	-	A
Default	0	000	0	000

The T1~T3 Registers set the T1~T3 time in One Shot Programming Mode.

**DT** Double Time

0  $T3 = T1$

1  $T3 = 2T1$

If A = 0~4,  $T1 = T3 = \tau \times 2^A$ ,  $\tau = 260\text{ms}$  (Typ.)

If A = 5~6, the breathing function disable.

If A = 7,  $T1 = T3 = 0.1\text{ms}$ .

If B = 1~7,  $T2 = \tau \times 2^{B-1}$ ,  $\tau = 260\text{ms}$  (Typ.)

If B = 0,  $T2 = 0\text{s}$ .

For example, the max T1&T3 is  $260\text{ms} \times 2^4 = 4.16\text{s}$ .

The max T2 is  $260\text{ms} \times 2^6 = 16.64\text{s}$ .

**Table 12 1Dh~22h T4 Register (OUT1~OUT6)**

Bit	D7:D6	D5:D4	D3:D0
Name	-	B	A
Default	00	00	0000

The T4 Registers set the T4 time in One Shot Programming Mode.

$$T4 = \tau \times A \times 2^B$$

A = 0~15, B = 0~3 and  $\tau = 260\text{ms}$  (Typ.)

For example, the max T4 is  $260\text{ms} \times 15 \times 2^3 = 31.2\text{s}$

## 26h Time Update Register

The data sent to the time registers (11h~16h, 1Ah~1Bh, 1Dh~22h) will be stored in temporary registers. A write operation of “0000 0000” data to the Time Update Register is required to update the registers (11h~16h, 1Ah~1Bh, 1Dh~22h).

## FFh Reset Register

Once user writes “0000 0000” data to the Reset Register, IS31FL3196A will reset all registers to default value. On initial power-up, the IS31FL3196A registers are reset to their default values for a blank display.

# IS31FL3196A

## FUNCTIONAL BLOCK DIAGRAM

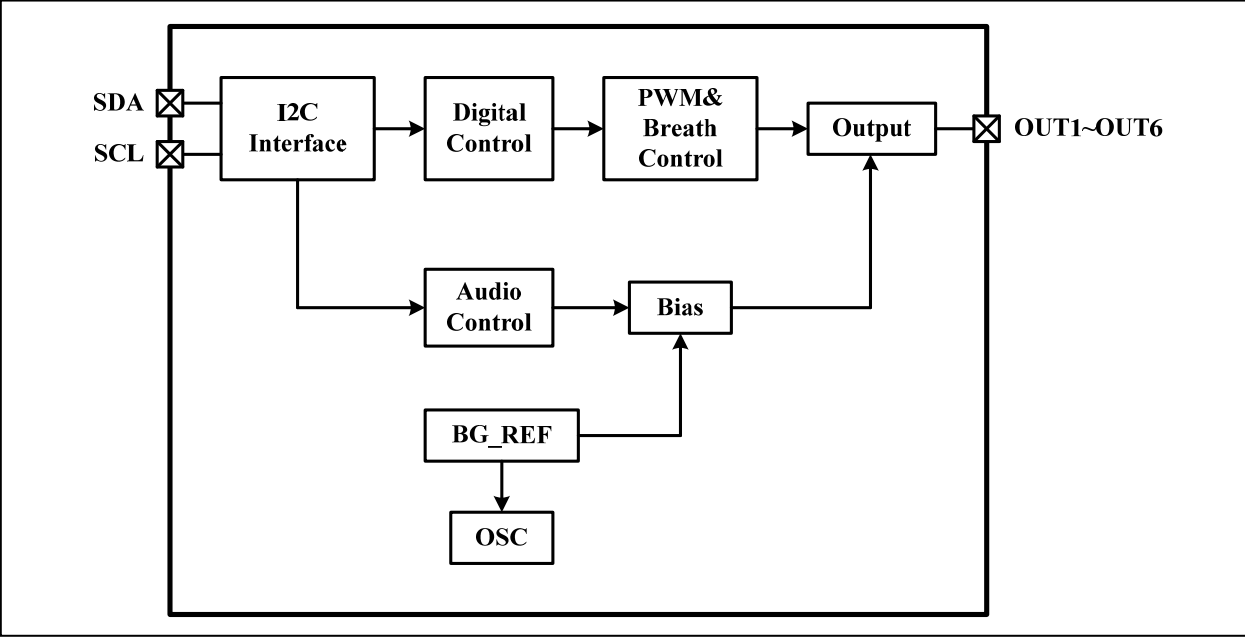

# IS31FL3196A

## APPLICATION INFORMATION

### GENERAL DESCRIPTION

IS31FL3196A is a 6-channel LED driver with two-dimensional auto breathing and PWM Control mode. It can drive six LEDs or two groups RGB.

### POWER ON SEQUENCE

IS31FL3196A provides a power-on reset feature that is controlled by  $V_{BAT}$  (voltage at pin1) supply voltage. When the  $V_{BAT}$  exceeds 2.0V (POR\_H, Typ.), the internal circuit starts to work. The reset signal will be generated to perform a power-on reset (POR\_H) operation, which will reset all control circuits and configuration registers until the internal power voltage become stable.

Before SDB pull high, the I2C operation is allowed. The SDB rising edge will reset the I2C bus.

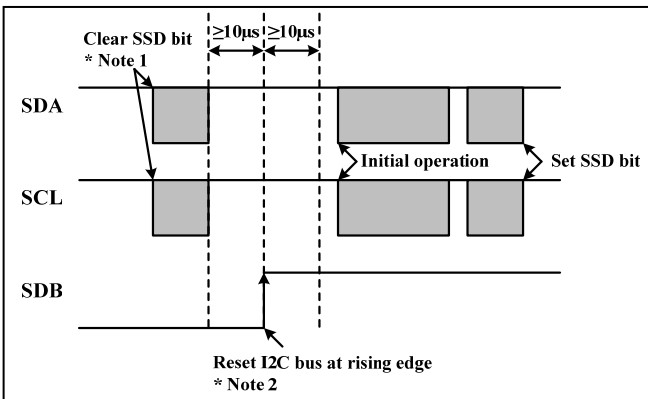

Figure 7 SDB Pin Sequence

**Note 1:** I2C operation is allowed when SDB is low.

**Note 2:** There should be no I2C operation 10µs before and after SDB rising edge.

In some case, like a mouse, when plug-out and quickly plug-in back the USB power, the LED will flash for a very short time. The reason is the power is not lower than the POR\_L voltage point 1.92V (Typ.), and the device still stores the previous setting data, if user pull-up the SDB high when power up, following with the initial operation, the LED will be ON between SDB rising edge and PWM initial effective, to avoid this, as above figure, a writing to 00h is recommended to shutdown the chip before pull-high the SDB pin.

### PWM CONTROL

By setting the RGBx bits of the Configuration Register 1 (03h) to "0", the IS31FL3196A will operate in PWM Control mode. The PWM Registers (07h~0Ch) can modulate LED brightness of 6 channels with 256 steps. For example, if the data in PWM Register is "0000 0100", then the PWM is the fourth step.

Writing new data continuously to the registers can modulate the brightness of the LEDs to achieve a breathing effect.

### RGB BREATHING CONTROL WITH AUTO COLOR CHANGING

By setting the RGBx bits of the Configuration Register 1 (03h) to "1", the IS31FL3196A will operate in One Shot Programming mode. In this mode each group RGB can be modulated breathing cycle independently by T0~T4. The full cycle is T1 to T4 (Figure 8). Setting different T0~T4 can achieve RGB breathing with auto color changing. The maximum intensity of each RGB can be adjusted independently by the PWM Registers (07h~0Ch).

Note, if IS31FL3196A operates in the One Shot Programming mode and then enters into the shutdown mode, an 8-bit data write operation to the Time Update Register is required to restart the LED breathing effect after the IC is re-enabled.

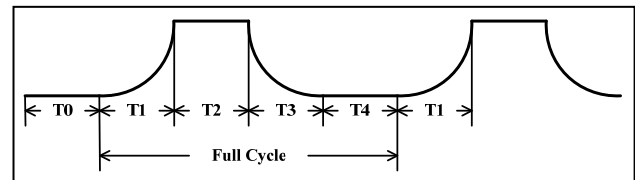

Figure 8 Breathing Timing

### RGB AUTO BREATHING CONTROL WITH COLOR SETTING

IS31FL3196A can pre-establish pattern achieving mixing color breathing. There are two groups RGB. Each RGB consists of three channels. Every channel has an 8-bit PWM data register. The color can be set by the PWM data register. For example, there are three PWM data: 20h, 80h, C8h, so the three data will determine a kind of color.

After setting the color, T0~T4 time register will be set to control the LED breathing panel. And T0~T4 time should be same for one RGB or the pre-established color will change.

### SEMI-AUTOMATIC BREATHING

By setting the RGBx bits of the Configuration Register 1 (03h) to "1" and the RM bit of the Ramping Mode Register (05h) to "1", the ramping function is enabled. HT is the time select bit. When HT bit is set to "0", T2 will be held forever, and the LED will remain at the programmed maximum intensity. When HT bit is set to "1", T3 will continue and T4 will be held, causing the LED to complete one breathing cycle and then remain off.

### AUDIO MODULATE DISPLAY MODE WITH AGC FUNCTION

In audio modulate display mode the output current can be modulated by the audio input signal. An AGC automatically adjusts the audio input gain to improve the dynamic range of the LED current modulation, thus improving the visual effect. When the input signal is

# IS31FL3196A

large such that the amplifier output begins to clip, the gain goes down. If the input signal is small, the gain increases, adjusting the output to provide a good dynamic response to the input signal.

The AGC can be disabled and the audio gain can be set by programming Configuration Register 1 (03h).

## BREATHING MARK FUNCTION

By setting the BME bit of the Breathing Mark Register (06h) to “1”, the breathing mark function is enabled. The CLK/V<sub>BM</sub> pin is used as V<sub>BM</sub>. If the BME bit sets to “0”, the breathing mark function disabled. The CLK/V<sub>BM</sub> pin is used as CLK, V<sub>BM</sub> is an output pin.

The breathing mark function is useful as a signal to notify the MCU when to update the color data. At the end of time period T1, V<sub>BM</sub> will induce a falling edge and hold logic low, so the new data can be sent by MCU at this time. At the end of T3, V<sub>BM</sub> will induce a rising edge and the MCU can send an update command to update all data simultaneously (Figure 8). The marking channel (OUT1~OUT6) is selected by the CSS bits of the Breathing Mark Register (06h).

When IS31FL3196A operates as slave, the breathing mark function is unavailable.

Notice the CLK/V<sub>BM</sub> output is push-pull structure and high logic is VCC (same as Pin 1), so when this pin is connected to controller GPIO, a 10kΩ resistor is recommended, otherwise the output pin voltage will higher than the GPIO pin.

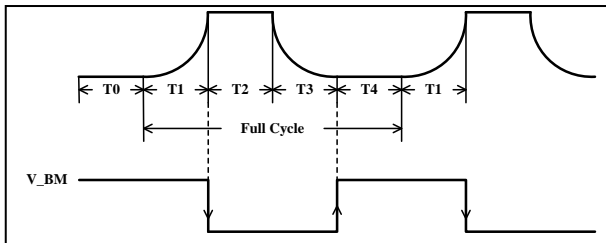

Figure 9 V<sub>BM</sub> Signal

## CASCADE FOR SYNCHRONIZATION OF CHIPS

Operating in the cascade mode can make two chips synchronize (Figure 2). By setting the CM bit of Configuration Register 2 (04h) to “0”, IS31FL3196A operates as a master. There are two pins (CLK, I\_AUD) for synchronization of chips. CLK pin can synchronize the breathing and I\_AUD pin can synchronize the audio current.

## SHUTDOWN MODE

Shutdown mode can either be used as a means of reducing power consumption or generating a flashing display (repeatedly entering and leaving shutdown mode). During shutdown mode all registers retain their data.

### Software Shutdown

By setting SSD bit of the Shutdown Register (00h) to “0”, the IS31FL3196A will operate in software shutdown mode, wherein they consume only 2μA (typ.) current. When the IS31FL3196A is in software shutdown mode, all current sources are switched off.

### Hardware Shutdown

The chip enters hardware shutdown mode when the SDB pin is pulled low, wherein they consume only 1μA (Typ.) current. When set SDB high, the rising edge will reset the I2C module, but the register information retains.

# IS31FL3196A

## CLASSIFICATION REFLOW PROFILES

Profile Feature	Pb-Free Assembly
Preheat & Soak Temperature min (T <sub>smin</sub> ) Temperature max (T <sub>smax</sub> ) Time (T <sub>smin</sub> to T <sub>smax</sub> ) (t <sub>s</sub> )	150°C 200°C 60-120 seconds
Average ramp-up rate (T <sub>smax</sub> to T <sub>p</sub> )	3°C/second max.
Liquidous temperature (T <sub>L</sub> ) Time at liquidous (t <sub>L</sub> )	217°C 60-150 seconds
Peak package body temperature (T <sub>p</sub> )*	Max 260°C
Time (t <sub>p</sub> )** within 5°C of the specified classification temperature (T <sub>c</sub> )	Max 30 seconds
Average ramp-down rate (T <sub>p</sub> to T <sub>smax</sub> )	6°C/second max.
Time 25°C to peak temperature	8 minutes max.

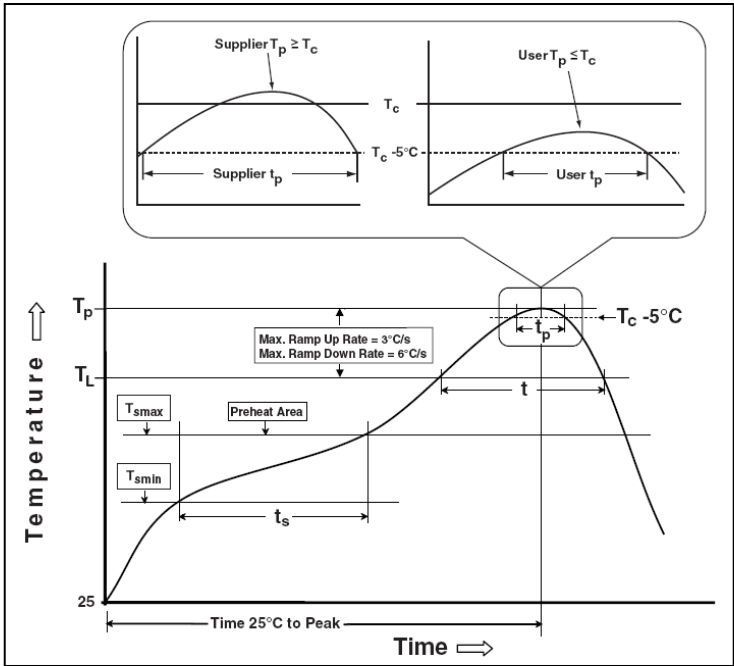
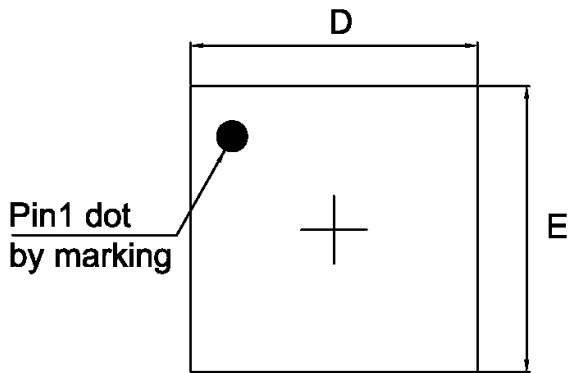

Figure 10 Classification Profile

# IS31FL3196A

## PACKAGE INFORMATION

### QFN-20



TOP VIEW

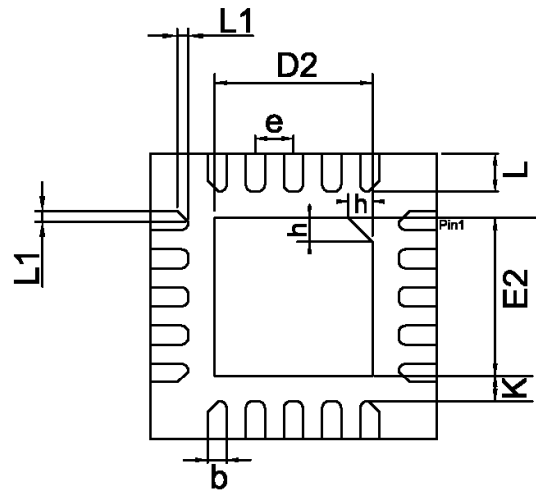

BOTTOM VIEW

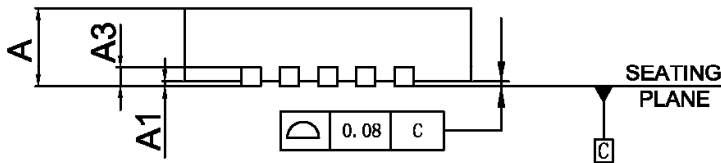

SIDE VIEW

SYMBOL	MILLIMETER		
	MIN	NOM	MAX
A	0.70	0.75	0.80
A1	0.00	—	0.05
A3	0.18	0.20	0.25
D	2.90	3.00	3.10
E	2.90	3.00	3.10
b	0.15	0.20	0.25
K	0.20	—	—
e	0.40 BSC		
L1	—	0.12	—
L	0.35	0.40	0.45
D2	1.55	1.65	1.75
E2	1.55	1.65	1.75
h	0.20	0.25	0.30

**NOTE:**

1. CONTROLLING DIMENSION : MM
2. REFERENCE DOCUMENT: JEDEC MO-220

# IS31FL3196A

## RECOMMENDED LAND PATTERN

### QFN-20

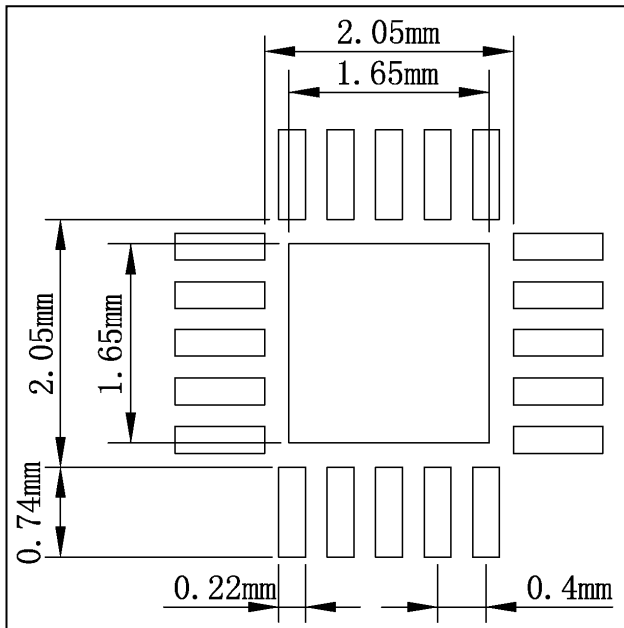

**Note:**

1. Land pattern complies to IPC-7351.
2. All dimensions in MM.
3. This document (including dimensions, notes & specs) is a recommendation based on typical circuit board manufacturing parameters. Since land pattern design depends on many factors unknown (eg. user's board manufacturing specs), user must determine suitability for use.

## REVISION HISTORY

Revision	Detail Information	Date
0A	Initial release	2016.08.09
A	Update POD, release to mass production	2016.08.29
B	1. Correct nine channels to six 2. Update $\theta_{JA}$	2017.03.21
C	Update land pattern	2017.11.01
D	1. $V_{IH}$ , $V_{IL}$ condition revise to $V_{CC}= 2.7V\sim 5.5V$ 2. Add STANDARD MODE in DIGITAL INPUT SWITCHING CHARACTERISTICS 3. Update $\theta_{JA}$ value 4. Update $I_{IH}/I_{IL}$ test condition 5. Add POWER ON SEQUENCE section in APPLICATION INFORMATION	2018.04.27
E	Update POD and land pattern	2020.08.20

## Looking for pricing, stock, or lifecycle information?

Click below to explore more details on WIN SOURCE:

- [View IS31FL3196A-QFLS2-TR on WIN SOURCE](#)
- [Lumissil Microsystems Information](#)

## Optimize Your Supply Chain with WIN SOURCE Solutions

- ✓ Global Sourcing Solution
- ✓ Obsolete Management
- ✓ Cost Control Management
- ✓ Shortage Management
- ✓ Alternative Solution
- ✓ Excess Inventory Management