



**THE DATASHEET OF
LTC2873CUFD#TRPBF**



Single-Bus RS485/RS232 Multiprotocol Transceiver with Switchable Termination

FEATURES

- One RS485 or One RS232 Transceiver
- 3V to 5.5V Supply Voltage
- Up to 20Mbps RS485
- Slew-Controlled RS232 Operation:
 - Selectable 1Mbps or 250kbps
- Automatic Selection of Integrated RS485 (120Ω) and RS232 (5kΩ) Termination Resistors
- High ESD: ±26kV HBM
- Logic Loopback Mode
- 1.7V to 5.5V Logic Interface
- Supports Up to 256 RS485 Nodes
- RS485 Receiver Failsafe Eliminates UART Lockup
- H-Grade Available (−40°C to 125°C)
- Available in 24-Pin 4mm × 5mm QFN Package

APPLICATIONS

- Software Selectable RS232/RS485/RS422 Interface
- Industrial Sensors and Actuators
- Alarm Systems
- Traffic Control and Monitoring
- Highway Signs and Jumbo Displays

DESCRIPTION

The LTC[®]2873 is a robust pin-configurable multiprotocol transceiver that supports RS232, RS485, and RS422 protocols while operating on a single 3V to 5.5V supply. The LTC2873 can be configured as a half-duplex RS485 transceiver or as an RS232 transceiver using the same two bus pins.

A pin-controlled integrated termination resistor allows for easy interface reconfiguration, eliminating external resistors and control relays. Loopback mode steers the driver inputs to the receiver outputs for diagnostic self-test. The RS485 receiver supports up to 256 nodes per bus, and features full failsafe operation for floating, shorted or terminated inputs.

An integrated DC/DC boost converter uses a tiny 2mm × 1.6mm inductor and one capacitor, eliminating the need for multiple supplies when driving RS232 levels.

All registered trademarks and trademarks are the property of their respective owners.

TYPICAL APPLICATION

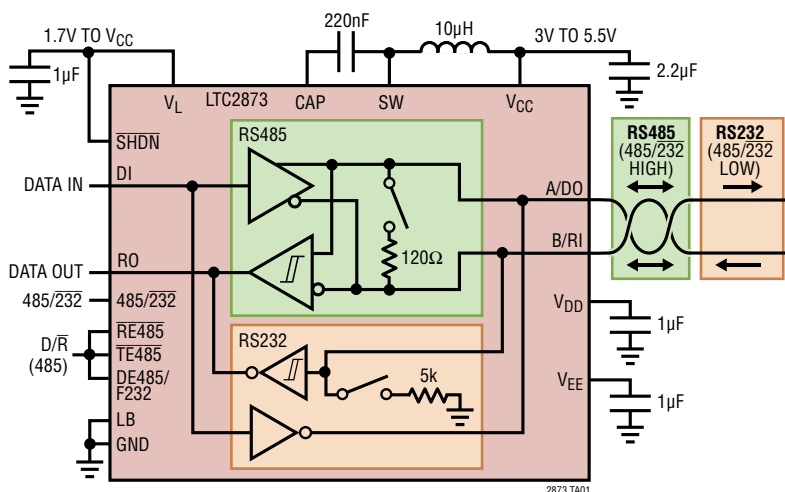

RS485/RS232 Mode Switching

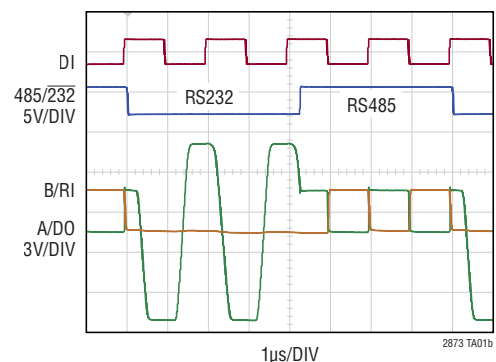

LTC2873

ABSOLUTE MAXIMUM RATINGS

(Notes 1 and 2)

Input Supplies

V_{CC}, V_L -0.3V to 7V

Generated Supplies

V_{DD} $V_{CC} - 0.3V$ to 7.5V

V_{EE} -7.5V to 0.3V

SW -0.3V to ($V_{DD} + 0.3V$)

CAP ($V_{EE} - 0.3V$) to 0.3V

A/DO, B/RI -15V to 15V

DI, 485/232, DE485/F232, RE485,

TE485, LB -0.3V to 7V

SHDN, RO -0.3V to ($V_L + 0.3V$)

Differential Terminator Voltage (Enabled)

(A/DO to B/RI) $\pm 6V$

Differential Terminator Voltage (Disabled)

(A/DO to B/RI) $\pm 30V$

Operating Temperature

LTC2873C 0°C to 70°C

LTC2873I -40°C to 85°C

LTC2873H -40°C to 125°C

Storage Temperature Range -65°C to 150°C

PIN CONFIGURATION

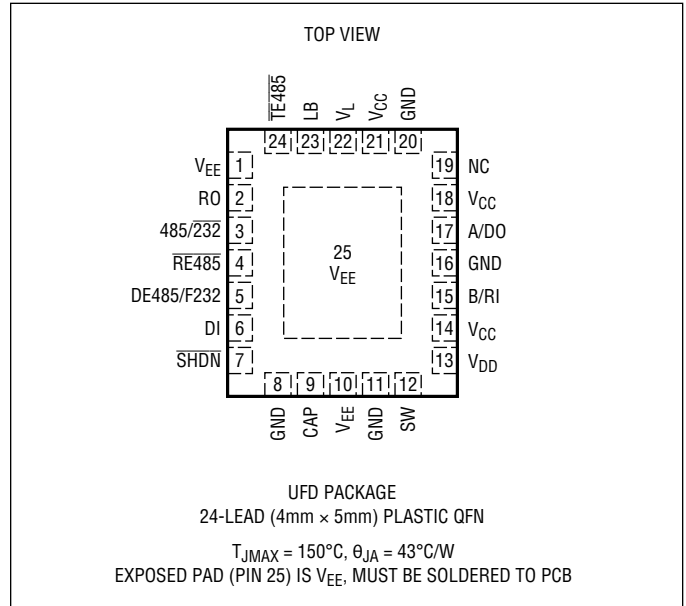

ORDER INFORMATION <http://www.linear.com/product/LTC2873#orderinfo>

| LEAD FREE FINISH | TAPE AND REEL | PART MARKING | PACKAGE DESCRIPTION | TEMPERATURE RANGE |
|------------------|-------------------|--------------|---------------------------------|-------------------|
| LTC2873CUFD#PBF | LTC2873CUFD#TRPBF | 2873 | 24-Lead (4mm × 5mm) Plastic QFN | 0°C to 70°C |
| LTC2873IUFD#PBF | LTC2873IUFD#TRPBF | 2873 | 24-Lead (4mm × 5mm) Plastic QFN | -40°C to 85°C |
| LTC2873HUFD#PBF | LTC2873HUFD#TRPBF | 2873 | 24-Lead (4mm × 5mm) Plastic QFN | -40°C to 125°C |

Consult LTC Marketing for parts specified with wider operating temperature ranges.

For more information on lead free part marking, go to: <http://www.linear.com/leadfree/>

For more information on tape and reel specifications, go to: <http://www.linear.com/tapeandree/>. Some packages are available in 500 unit reels through designated sales channels with #TRMPBF suffix.

ELECTRICAL CHARACTERISTICS

The ● denotes the specifications which apply over the full operating temperature range, otherwise specifications are at $T_A = 25^\circ\text{C}$. $V_{CC} = V_L = 3.3\text{V}$, $\overline{\text{TE485}} = V_L$, $\text{LB} = 0\text{V}$ unless otherwise noted. (Notes 2, 6)

| SYMBOL | PARAMETER | CONDITIONS | MIN | TYP | MAX | UNITS | |
|-------------------------------|--------------------------------------------------------------------------------------------------------|------------------------------------------------------------------------------------------------------------------------------------------------------------------------------------------------------------------------------|------------------|-----------------|----------------------------------|------------------|----|
| Supplies | | | | | | | |
| V_{CC} | Supply Voltage Operating Range | | ● | 3 | 5.5 | V | |
| V_L | Logic Supply Voltage Operating Range | $V_L \leq V_{CC}$ | ● | 1.7 | V_{CC} | V | |
| | V_{CC} Supply Current in Shutdown Mode | $\overline{\text{SHDN}} = 0\text{V}$ | ● | 8 | 30 | μA | |
| | V_{CC} Supply Current in RS232 Mode or RS485 Mode, Driver and Receiver Enabled, Termination Disabled | No Load, $\overline{\text{SHDN}} = \overline{\text{TE485}} = \overline{\text{DE485/F232}} = V_L$ $\overline{\text{RE485}} = 0$ | ● | 4 | 9 | mA | |
| | V_{CC} Supply Current in RS485 Mode with Receiver and Termination Enabled, Driver Disabled | No Load, $\overline{\text{SHDN}} = 485/232 = V_L$ $\overline{\text{DE485/F232}} = \overline{\text{RE485}} = \overline{\text{TE485}} = 0$ | ● | 4 | 9 | mA | |
| | V_L Supply Current in Any Mode | No Load | ● | 0 | 5 | μA | |
| Power Supply Generator | | | | | | | |
| V_{DD} | Regulated V_{DD} Output Voltage | $\overline{\text{SHDN}} = V_L$, No Load | | 7.0 | | V | |
| V_{EE} | Regulated V_{EE} Output Voltage | $\overline{\text{SHDN}} = V_L$, No Load | | -6.3 | | V | |
| RS485 Driver | | | | | | | |
| $ V_{OD} $ | Differential Output Voltage | $R_L = \text{Open}$, $V_{CC} = 3\text{V}$ (Figure 1) $R_L = 27\Omega$, $V_{CC} = 4.5\text{V}$ (Figure 1) $R_L = 27\Omega$, $V_{CC} = 3\text{V}$ (Figure 1) $R_L = 50\Omega$, $V_{CC} = 3.13\text{V}$ (Figure 1) | ● ● ● ● | 2.1 1.5 2 | V_{CC} V_{CC} V_{CC} | V V V V | |
| $\Delta V_{OD} $ | Difference in Magnitude of Differential Output Voltage for Complementary Output States | $R_L = 27\Omega$, $V_{CC} = 3\text{V}$ (Figure 1) $R_L = 50\Omega$, $V_{CC} = 3.13\text{V}$ (Figure 1) | ● ● | | 0.2 0.2 | V | |
| V_{OC} | Common Mode Output Voltage | $R_L = 27\Omega$ or 50Ω (Figure 1) | ● | | 3 | V | |
| $\Delta V_{OC} $ | Difference in Magnitude of Common Mode Output Voltage for Complementary Output States | $R_L = 27\Omega$ or 50Ω (Figure 1) | ● | | 0.2 | V | |
| I_{OSD485} | Maximum Short-Circuit Current | $-7\text{V} \leq V_{OUT} \leq 12\text{V}$ (Figure 2) | ● | | ± 250 | mA | |
| RS485 Receiver | | | | | | | |
| I_{IN485} | Input Current (A/DO, B/RI) | (A/DO or B/RI) = 12V or -7V, $V_{CC} = 0\text{V}$ or 3.3V (Figure 3) | ● | -100 | 125 | μA | |
| R_{IN485} | Input Resistance (A/DO, B/RI) | (A/DO or B/RI) = 12V or -7V, $V_{CC} = 0\text{V}$ or 3.3V (Figure 3) | | 125 | | k Ω | |
| | Differential Input Signal Threshold Voltage (A/DO to B/RI) | $-7\text{V} \leq (\text{A/DO or B/RI}) \leq 12\text{V}$ | ● | | ± 200 | mV | |
| | Input Hysteresis | $B = 0\text{V}$ | | 220 | | mV | |
| | Differential Input Failsafe Rising Threshold Voltage | $-7\text{V} \leq (\text{A/DO or B/RI}) \leq 12\text{V}$, (A/DO - B/RI) Rising | ● | -200 | -70 | -20 | mV |
| | Input DC Failsafe Hysteresis | | | 40 | | mV | |
| V_{OL} | Receiver Output Low Voltage | Output Low, $I(R_O) = 3\text{mA}$ (Sinking), $3\text{V} \leq V_L \leq 5.5\text{V}$ | ● | | 0.4 | V | |
| | | Output Low, $I(R_O) = 1\text{mA}$ (Sinking), $1.7\text{V} \leq V_L < 3\text{V}$ | ● | | 0.4 | V | |

ELECTRICAL CHARACTERISTICS The ● denotes the specifications which apply over the full operating temperature range, otherwise specifications are at $T_A = 25^\circ\text{C}$. $V_{CC} = V_L = 3.3\text{V}$, $\overline{TE485} = V_L$, $LB = 0\text{V}$ unless otherwise noted. (Notes 2, 6)

| SYMBOL | PARAMETER | CONDITIONS | MIN | TYP | MAX | UNITS | |
|------------|--------------------------------------------------|--------------------------------------------------------------------------------------------------------------------|-----|-------------|-----------|---------------|----------|
| V_{OH} | Receiver Output High Voltage | Output High, $I(RO) = -3\text{mA}$ (Sourcing), $3\text{V} \leq V_L \leq 5.5\text{V}$ | ● | $V_L - 0.4$ | | V | |
| | | Output High, $I(RO) = -1\text{mA}$ (Sourcing), $1.7\text{V} \leq V_L < 3\text{V}$ | ● | $V_L - 0.4$ | | V | |
| | Three-State (High Impedance) Output Current (RO) | $0\text{V} \leq RO \leq V_L$, $V_L = 5.5\text{V}$, $\overline{RE485} = V_L$ | ● | 0 | ± 5 | μA | |
| | Short-Circuit Current (RO) | $0\text{V} \leq RO \leq V_L$, $V_L = 5.5\text{V}$ | ● | | ± 135 | mA | |
| R_{TERM} | Terminating Resistor | $\overline{TE485} = 0\text{V}$, $V_{AB} = 2\text{V}$, $V_B = -7\text{V}$, 0V , 10V (Figure 8) | ● | 108 | 120 | 156 | Ω |

RS232 Driver

| | | | | | | | |
|-----------|------------------------------|-----------------------------------------------------|---|----|----------|----------|-------------|
| V_{OLD} | Output Low Voltage | $R_L = 3\text{k}\Omega$, $V_{EE} \leq -6\text{V}$ | ● | -5 | -5.5 | V_{EE} | V |
| V_{OHD} | Output High Voltage | $R_L = 3\text{k}\Omega$, $V_{DD} \geq 6.5\text{V}$ | ● | 5 | 5.9 | V_{DD} | V |
| | Output Short-Circuit Current | Driver Output = 0V | ● | | ± 25 | ± 90 | mA |

RS232 Receiver

| | | | | | | | |
|--|------------------------------|------------------------------------------------------------------------|---|-------------|----------|----------|------------------|
| | Input Threshold Voltage | | ● | 0.6 | 1.5 | 2.5 | V |
| | Input Hysteresis | | ● | 0.1 | 0.4 | 1.0 | V |
| | Output Low Voltage | $I(RO) = 1\text{mA}$ (Sinking), $1.7\text{V} \leq V_L < 5.5\text{V}$ | ● | | | 0.4 | V |
| | Output High Voltage | $I(RO) = -1\text{mA}$ (Sourcing), $1.7\text{V} \leq V_L < 5.5\text{V}$ | ● | $V_L - 0.4$ | | | V |
| | Input Resistance | $-15\text{V} \leq B/RI \leq 15\text{V}$, $485/232 = 0\text{V}$ | ● | 3 | 5 | 7 | $\text{k}\Omega$ |
| | Output Short-Circuit Current | $V_L = 5.5\text{V}$, $0\text{V} \leq RO \leq V_L$ | ● | | ± 25 | ± 50 | mA |

Logic Inputs

| | | | | | | | |
|--|-------------------|--|---|-----|---|------------------|---------------|
| | Threshold Voltage | | ● | 0.4 | | $0.75 \cdot V_L$ | V |
| | Input Current | | ● | | 0 | ± 5 | μA |

ESD

| | | | | | | | |
|--|-----------------------------|---------------------------------------------------------------------|--|--|----------|--|-------------|
| | Interface Pins (A/DO, B/RI) | Human Body Model to GND or V_{CC} , Powered or Unpowered (Note 5) | | | ± 26 | | kV |
| | All Other Pins | Human Body Model (Note 5) | | | ± 4 | | kV |

SWITCHING CHARACTERISTICS

The ● denotes the specifications which apply over the full operating temperature range, otherwise specifications are at $T_A = 25^\circ\text{C}$. $V_{CC} = V_L = 3.3\text{V}$, $\overline{\text{TE485}} = V_L$, $\text{LB} = 0\text{V}$ unless otherwise noted. (Notes 2, 6)

| SYMBOL | PARAMETER | CONDITIONS | MIN | TYP | MAX | UNITS |
|------------------------------------------------------------------------------------------|----------------------------------------------------------------------------------------------------------------------------------------------------|-------------------------------------------------------------------------------------------------------------------------------------------------------------------------------------------------------------|-------------|--------------------|------------------------|----------------------------------------------------------------------------|
| RS485 Switching Characteristics | | | | | | |
| | Maximum Data Rate | (Note 3) (Figure 15) | ● | 20 | | Mbps |
| t_{PLHD485} , t_{PHLD485} | Driver Propagation Delay | $R_{\text{DIFF}} = 54\Omega$, $C_L = 100\text{pF}$ (Figure 4) | ● | 20 | 70 | ns |
| | Driver Propagation Delay Difference $R_{\text{DIFF}} = 54\Omega$, $C_L = 100\text{pF}$ (Figure 4) $t_{\text{PLHD485}} - t_{\text{PHLD485}}$ | | ● | 0 | ± 6 | ns |
| t_{SKEWD485} | Driver Skew (A/DO to B/RI) | $R_{\text{DIFF}} = 54\Omega$, $C_L = 100\text{pF}$ (Figure 4) | | 0 | ± 8 | ns |
| t_{RD485} , t_{FD485} | Driver Rise or Fall Time | $R_{\text{DIFF}} = 54\Omega$, $C_L = 100\text{pF}$ (Figure 4) | | 7.5 | 12.5 | ns |
| t_{ZLD485} , t_{ZHD485} , t_{LZD485} , t_{HZD485} | Driver Output Enable or Disable Time | $\overline{\text{SHDN}} = V_L$, $R_L = 500\Omega$, $C_L = 50\text{pF}$, $\overline{\text{DE485}} \uparrow$ and \downarrow (Figure 5) | ● | | 120 | ns |
| t_{ZHSD485} , t_{ZLSD485} | Driver Enable from Shutdown Time (Note 7) | $\overline{\text{DE485}}/\overline{\text{F232}} = V_L$, $R_L = 500\Omega$, $C_L = 50\text{pF}$, $\overline{\text{SHDN}} \uparrow$ (Figure 5) | ● | 4 | 12 | μs |
| t_{HZSD485} , t_{LZSD485} | Driver Output Disable Into Shutdown Time | $\overline{\text{DE485}}/\overline{\text{F232}} = V_L$, $R_L = 500\Omega$, $C_L = 50\text{pF}$, $\overline{\text{SHDN}} \downarrow$ (Figure 5) | ● | 0.5 | 1 | μs |
| t_{PLHR485} , t_{PHLR485} | Receiver Input to Output Time | $C_L = 15\text{pF}$, $V_{\text{CM}} = 1.5\text{V}$, $ \text{A/DO to B/RI} = 1.5\text{V}$, (Figure 6) | ● | 45 | 85 | ns |
| t_{SKEWR485} | Differential Receiver Skew $t_{\text{PLHR485}} - t_{\text{PHLR485}}$ | $C_L = 15\text{pF}$ (Figure 6) | ● | 0 | ± 9 | ns |
| t_{RR485} , t_{FR485} | Receiver Output Rise or Fall Time | $C_L = 15\text{pF}$ (Figure 6) | ● | 3 | 15 | ns |
| t_{ZLR485} , t_{ZHR485} , t_{LZR485} , t_{LZR485} | Receiver Output Enable or Disable Time | $\overline{\text{485/232}} = \overline{\text{SHDN}} = V_L$, $R_L = 1\text{k}\Omega$, $C_L = 15\text{pF}$, $\overline{\text{RE485}} \downarrow$ and \uparrow (Figure 7) | ● | 12 | 85 | ns |
| t_{ZHSR485} , t_{ZLSR485} | Receiver Enable from Shutdown Time (Note 7) | $\overline{\text{485/232}} = V_L$, $\overline{\text{RE485}} = 0\text{V}$, $R_L = 1\text{k}\Omega$, $C_L = 15\text{pF}$, $\overline{\text{SHDN}} \uparrow$ (Figure 7) | ● | 4 | 12 | μs |
| t_{HZSR485} , t_{LZSR485} | Receiver Output Disable Into Shutdown Time | $\overline{\text{485/232}} = V_L$, $\overline{\text{RE485}} = 0\text{V}$, $R_L = 1\text{k}\Omega$, $C_L = 15\text{pF}$, $\overline{\text{SHDN}} \downarrow$ (Figure 7) | ● | 0.5 | 1 | μs |
| t_{RTEN485} , t_{RTZ485} | Termination Enable or Disable Time | $\overline{\text{485/232}} = V_L$, $\overline{\text{SHDN}} = V_L$, $B = 0$, (A/DO to B/RI) = 2V (Figure 8) | ● | | 100 | μs |
| RS232 Switching Characteristics | | | | | | |
| | Maximum Data Rate (Figure 15) | $R_L = 3\text{k}\Omega$, $C_L = 2.5\text{nF}$, (Fast, Slow Modes) $R_L = 3\text{k}\Omega$, $C_L = 1\text{nF}$, (Fast, Slow Modes) $R_L = 3\text{k}\Omega$, $C_L = 0.25\text{nF}$, (Fast Mode) | ● ● ● | 100 250 1000 | | kbps kbps kbps |
| | Driver Slew Rate (Figure 9) | $R_L = 3\text{k}\Omega$, $C_L = 2.5\text{nF}$, (Fast, Slow Modes) $R_L = 3\text{k}\Omega$, $C_L = 50\text{pF}$, (Slow Mode) $R_L = 3\text{k}\Omega$, $C_L = 50\text{pF}$, (Fast Mode) | ● ● ● | 2 | 30 150 | $\text{V}/\mu\text{s}$ $\text{V}/\mu\text{s}$ $\text{V}/\mu\text{s}$ |
| t_{PHLD232} , t_{PLHD232} | Driver Propagation Delay (Figure 9) | $R_L = 3\text{k}\Omega$, $C_L = 50\text{pF}$, (Slow Mode) $R_L = 3\text{k}\Omega$, $C_L = 50\text{pF}$, (Fast Mode) | ● ● | 1.5 0.4 | 3 1 | μs μs |
| t_{SKEWD232} | Driver Skew (Figure 9) | $R_L = 3\text{k}\Omega$, $C_L = 50\text{pF}$, (Slow Mode) $R_L = 3\text{k}\Omega$, $C_L = 50\text{pF}$, (Fast Mode) | | 0 0 | ± 400 ± 100 | ns ns |
| t_{ZLSD232} , t_{ZHSD232} | Driver Enable from Shutdown Time (Figure 7) | $V_{\text{DD}} = 7.0\text{V}$, $V_{\text{EE}} = -6.3\text{V}$, $\overline{\text{485/232}} = 0\text{V}$, $R_L = 3\text{k}\Omega$, $C_L = 50\text{pF}$, $\overline{\text{SHDN}} \uparrow$ (Figure 10) | ● | 5 | 12 | μs |
| t_{LZSD232} , t_{HZSD232} | Driver Output Disable into Shutdown Time | $\overline{\text{485/232}} = 0\text{V}$, $R_L = 3\text{k}\Omega$, $C_L = 50\text{pF}$, $\overline{\text{SHDN}} \downarrow$ (Figure 10) | ● | 0.6 | 2 | μs |
| t_{PLHR232} , t_{PHLR232} | Receiver Propagation Delay | $C_L = 150\text{pF}$ (Figure 11) | ● | 60 | 200 | ns |
| t_{SKEWR232} | Receiver Skew | $C_L = 150\text{pF}$ (Figure 11) | | 25 | | ns |
| t_{RR232} , t_{FR232} | Receiver Output Rise or Fall Time | $C_L = 150\text{pF}$ (Figure 11) | ● | 70 | 200 | ns |

SWITCHING CHARACTERISTICS

The ● denotes the specifications which apply over the full operating temperature range, otherwise specifications are at $T_A = 25^\circ\text{C}$. $V_{CC} = V_L = 3.3\text{V}$, $\overline{\text{TE485}} = V_L$, $\text{LB} = 0\text{V}$ unless otherwise noted. (Notes 2, 6)

| SYMBOL | PARAMETER | CONDITIONS | MIN | TYP | MAX | UNITS |
|--------------------------------|---------------------------------------------|---------------------------------------------------------------------------------------------------------------------------------------------------------------------------|-----|-----|-----|---------------|
| $t_{ZLSR232}$, $t_{ZHRSR232}$ | Receiver Enable from Shutdown Time (Note 7) | $V_{DD} = 7.0\text{V}$, $V_{EE} = -6.3\text{V}$, $485/\overline{232} = 0\text{V}$, $R_L = 1\text{k}\Omega$, $C_L = 150\text{pF}$, $\text{SHDN} \uparrow$ (Figure 12) | ● | 5 | 12 | μs |
| $t_{LZSR232}$, $t_{HZSR232}$ | Receiver Disable Into Shutdown Time | $485/\overline{232} = 0\text{V}$, $R_L = 1\text{k}\Omega$, $C_L = 150\text{pF}$, $\text{SHDN} \downarrow$ (Figure 12) | ● | 0.4 | 2 | μs |

Mode Change Characteristics

| | | | | | | |
|-------------|----------------------------------------------------------------------------|-------------|---|-----|-----|---------------|
| t_{RDY} | V_{DD} and V_{EE} Supply Rise Time (Time from Shutdown to RS485 Ready) | (Figure 13) | ● | 0.2 | 1 | ms |
| t_{DR232} | Time from RS485 Mode to RS232 Mode RS232 Driver Ready | (Figure 14) | ● | 0.2 | 1 | μs |
| t_{R232} | Time from RS485 Mode to RS232 Mode RS232 Receiver Ready | (Figure 14) | ● | 0.8 | 3 | μs |
| t_{DR485} | Time from RS232 Mode to RS485 Mode RS485 Driver and Receiver Ready | (Figure 14) | ● | 70 | 250 | ns |

Note 1: Stresses beyond those listed under Absolute Maximum Ratings may cause permanent damage to the device. Exposure to any Absolute Maximum Rating condition for extended periods may affect device reliability and lifetime.

Note 2: All currents into device pins are positive; all currents out of device pins are negative. All voltages are referenced to device ground unless otherwise specified.

Note 3: Guaranteed by other measured parameters and not tested directly.

Note 4: Time from $\text{SHDN} \uparrow$ until $V_{DD} \geq 5\text{V}$ and $V_{EE} \leq -5\text{V}$. External components as shown in the Typical Application section.

Note 5: Guaranteed by design and not subject to production test.

Note 6: Testing was done with V_{DD} and V_{EE} back driven to valid supply levels for functions that require these supplies, unless otherwise noted.

Note 7: If enabling from shutdown, where V_{DD} and V_{EE} supplies are collapsed, allow the extra time it takes to generate valid V_{DD} and V_{EE} supplies (t_{RDY}).

TYPICAL PERFORMANCE CHARACTERISTICS $T_A = 25^\circ\text{C}$, $V_{CC} = V_L = 3.3\text{V}$, unless otherwise noted.

V_{CC} Supply Current vs Supply Voltage in Shutdown Mode

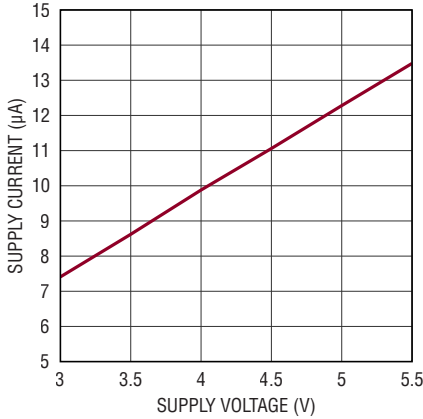

V_{CC} Supply Current vs Supply Voltage in RDY Mode

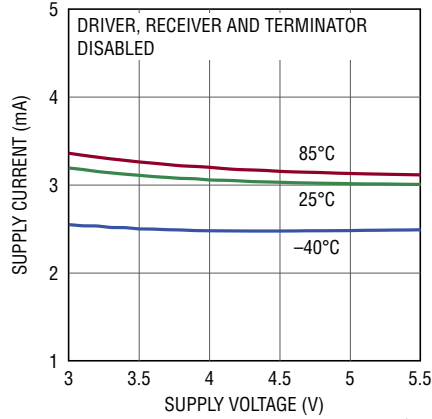

V_{CC} Supply Current vs RS485 Data Rate

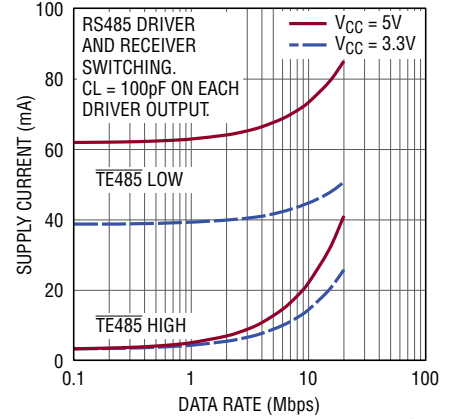

V_{CC} Supply Current vs RS232 Data Rate in Slow Mode

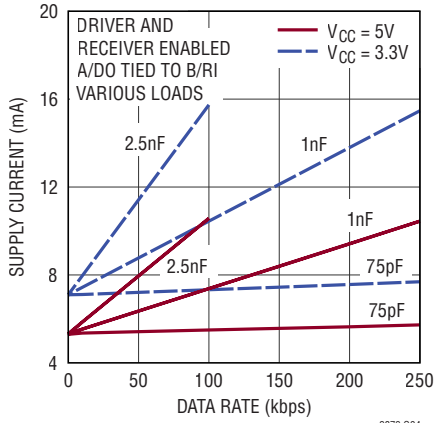

V_{CC} Supply Current vs RS232 Data Rate in Fast Mode

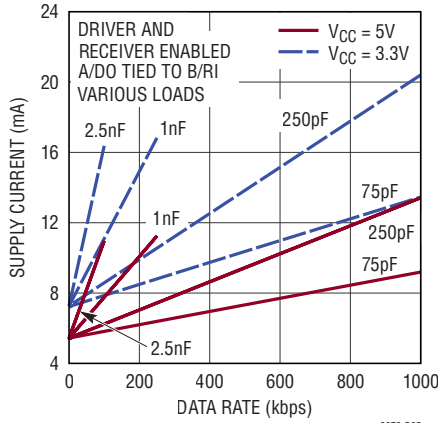

RS485 Driver Differential Output Voltage vs Temperature

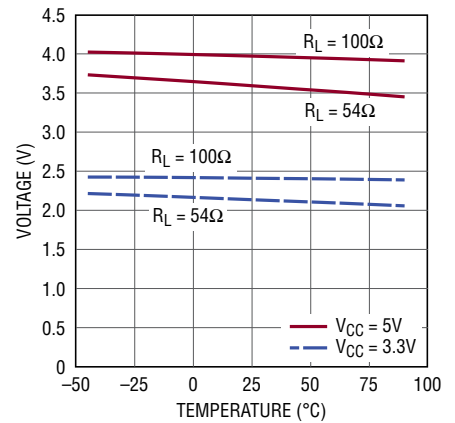

RS485 Driver Propagation Delay vs Temperature

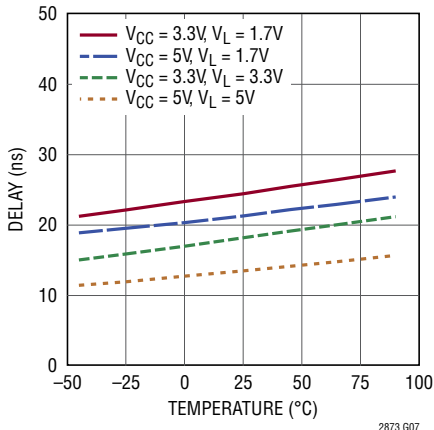

RS485 Driver Skew vs Temperature

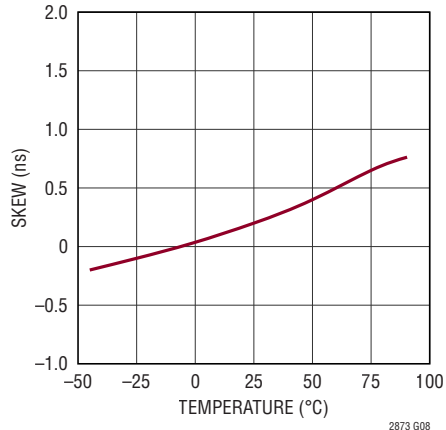

RS485 Driver Short-Circuit Current vs Short-Circuit Voltage

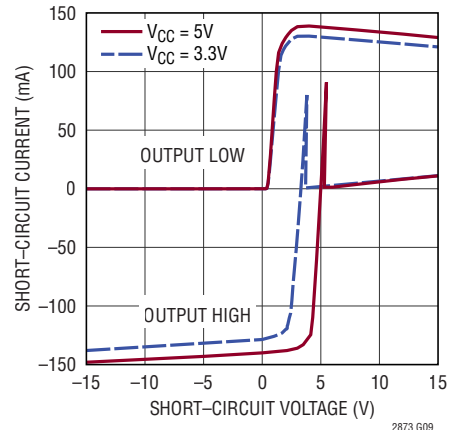

TYPICAL PERFORMANCE CHARACTERISTICS $T_A = 25^\circ\text{C}$, $V_{CC} = V_L = 3.3\text{V}$, unless otherwise noted.

RS485 Receiver Propagation Delay vs Temperature

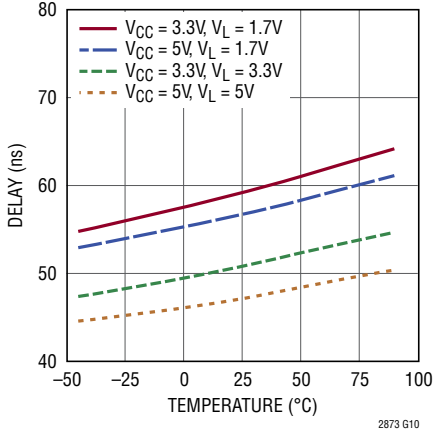

RS485 Receiver Skew vs Temperature

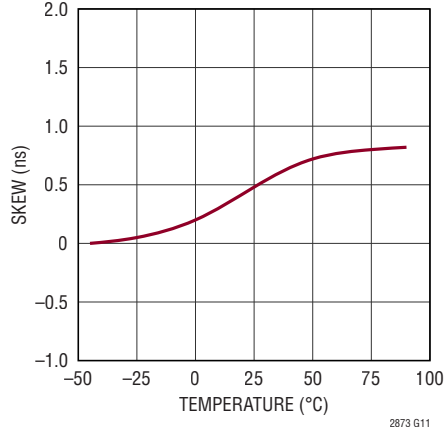

RS485 Receiver Output Voltage vs Load Current

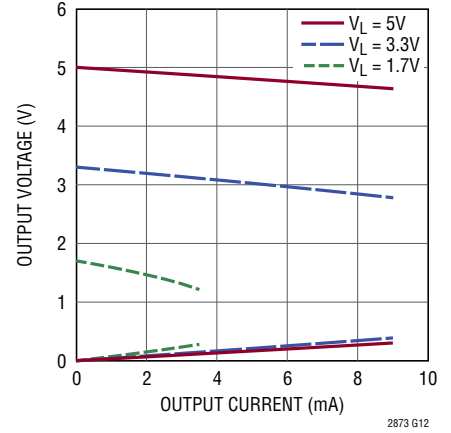

RS232 Receiver Input Threshold vs Temperature

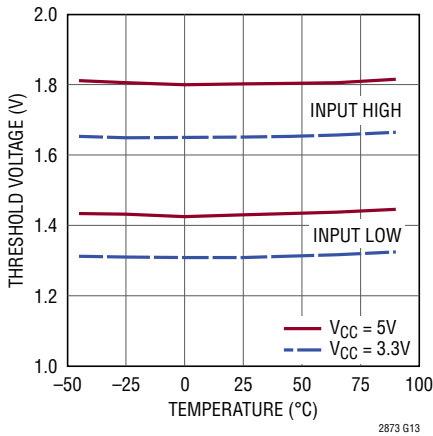

RS232 Receiver Output Voltage vs Load Current

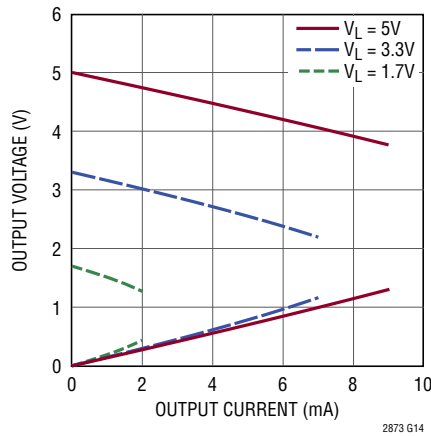

RS485 Termination Resistance vs Temperature

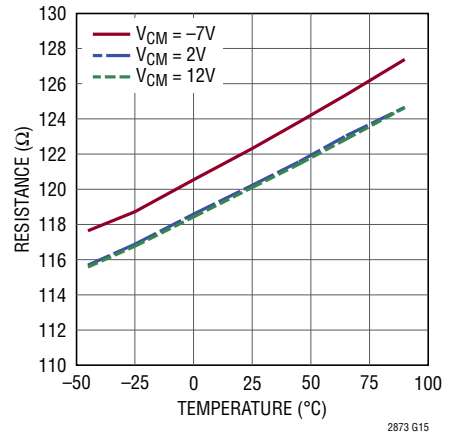

RS232 Driver Switching at 250kbps

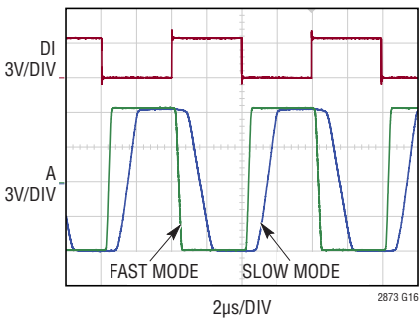

RS232 Operation at 1Mbps FAST Mode (DE485/F232 High)

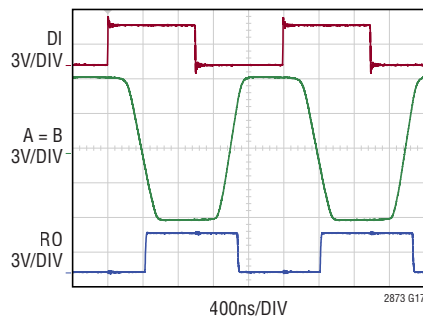

LTC2873 Drivers Changing Modes

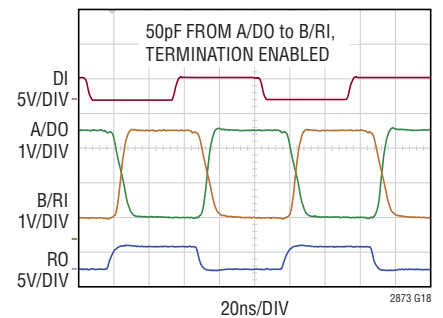

TYPICAL PERFORMANCE CHARACTERISTICS $T_A = 25^\circ\text{C}$, $V_{CC} = V_L = 3.3\text{V}$, unless otherwise noted.

RS232/RS485 Mode Switching

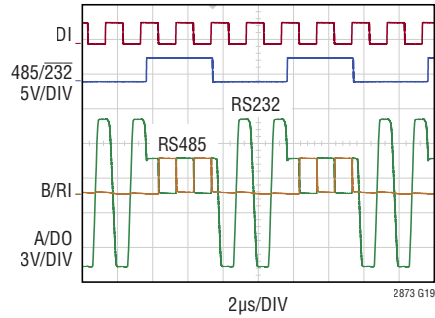

Transition from Shutdown to RS232 Driver Output Going High and Low

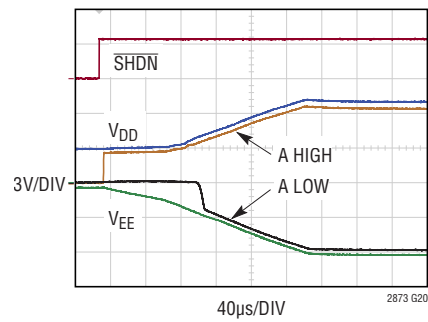

V_{DD} and V_{EE} Ripple

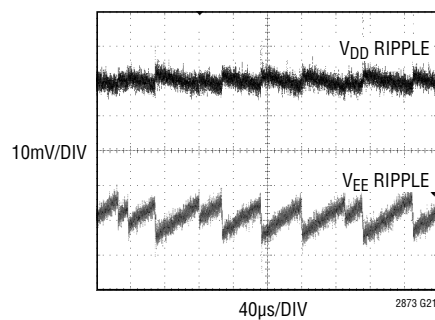

RS485 READY MODE,
ALL DRIVERS AND RECEIVERS DISABLED

PIN FUNCTIONS

V_{EE} (Pins 1, 10, 25): Generated Negative Supply Voltage for RS232 Driver ($-6.3V$). Tie all pins together and connect $1\mu F$ capacitor between V_{EE} (Pin 10) and GND. Exposed pad (Pin 25) must be soldered to PCB to maintain low thermal resistance.

RO (Pin 2): RS485 Differential Receiver Output and RS232 Receiver Output. Logic level referenced to GND and V_L .

485/232 (Pin 3): Interface Select Input. A logic low enables RS232 mode and a high enables RS485 mode. The mode determines which transceiver inputs and outputs are accessible at the LTC2873 pins. Logic level referenced to GND and V_L . Do not float.

$\overline{RE485}$ (Pin 4): RS485 Receiver Enable. In RS485 mode, a logic high disables the RS485 receiver, leaving its output Hi-Z and a logic low enables the RS485 receiver. This input has no function in RS232 mode (485/232 low). Logic level referenced to GND and V_L . Do not float.

DE485/F232 (Pin 5): RS485 Driver Enable and RS232 Fast Mode Enable. In RS485 mode (485/232 high), a logic low disables the RS485 driver leaving the driver outputs in a Hi-Z state and a logic high enables the RS485 driver. In RS232 mode (485/232 low), a logic high enables Fast mode with maximum data rate of 1Mbps. A logic low enables Slow mode with a maximum data rate of 250kbps. Logic level referenced to GND and V_L . Do not float.

DI (Pin 6): RS485 and RS232 Driver Input. Logic level referenced to GND and V_L . Do not float.

SHDN (Pin 7): Shutdown Control. A logic low disables the LTC2873 into low power shutdown state, independent of the other inputs. Driver and receiver outputs become Hi-Z. Logic level referenced to GND and V_L . Do not float.

GND (Pin 8, 11, 16, 20): Ground. Tie all four pins together.

CAP (Pin 9): Charge Pump Capacitor for Generated Negative Supply Voltage V_{EE} . Connect a 220nF capacitor between CAP and SW.

SW (Pin 12): Switch Pin. Connect $10\mu H$ inductor between SW and V_{CC} . See Inductor Selection section for further details.

V_{DD} (Pin 13): Generated Positive Supply Voltage for RS232 Driver ($+7.0V$). Connect $1\mu F$ capacitor between V_{DD} and GND.

V_{CC} (Pin 14, 18, 21): Input Supply (3V to 5.5V). Tie all three pins together and connect a $2.2\mu F$ or larger capacitor between V_{CC} (adjacent to V_{DD}) and GND.

B/RI (Pin 15): RS485 Negative Receiver Input and Driver Output. In RS232 mode, this is the RS232 receiver input.

A/DO (Pin 17): RS485 Positive Receiver Input and Driver Output. In RS232 mode, this is the RS232 driver output.

NC (Pin 19): Not connected internally.

V_L (Pin 22): Logic Supply (1.7V to 5.5V) for the Receiver Outputs, Driver Inputs, and Control Inputs. Bypass this pin to GND with a $0.1\mu F$ capacitor if not tied to V_{CC} . Keep $V_L \leq V_{CC}$ for operation guaranteed to meet specifications. However, $V_L > V_{CC}$ will not damage the device, provided that absolute maximum limits are respected. See “ V_L Logic Supply and Logic Pins” in Applications section for more information.

LB (Pin 23): Loopback Enable. A logic high enables logic loopback diagnostic mode, internally routing the driver input logic signals to the receiver output pins. This applies to RS232 and RS485 operation. The targeted receiver must be enabled for the loopback signal to be available on its output. A logic low disables Loopback mode. In Loopback mode, signals are not inverted from driver inputs to receiver outputs. Logic level referenced to GND and V_L . Do not float.

$\overline{TE485}$ (Pin 24): RS485 Termination Enable. In RS485 mode, a logic low enables a 120Ω resistor between pins A/DO and B/RI. A logic high opens the resistor between A/DO and B/RI, leaving the pins unterminated. In RS485 mode, the $5k$ resistor between B/RI and GND is never engaged. In RS232 mode, the 120Ω resistor between A/DO and B/RI is never engaged, regardless of the state of $\overline{TE485}$, and the $5k$ resistor between B/RI and GND is always engaged. Logic level referenced to GND and V_L . Do not float.

BLOCK DIAGRAM

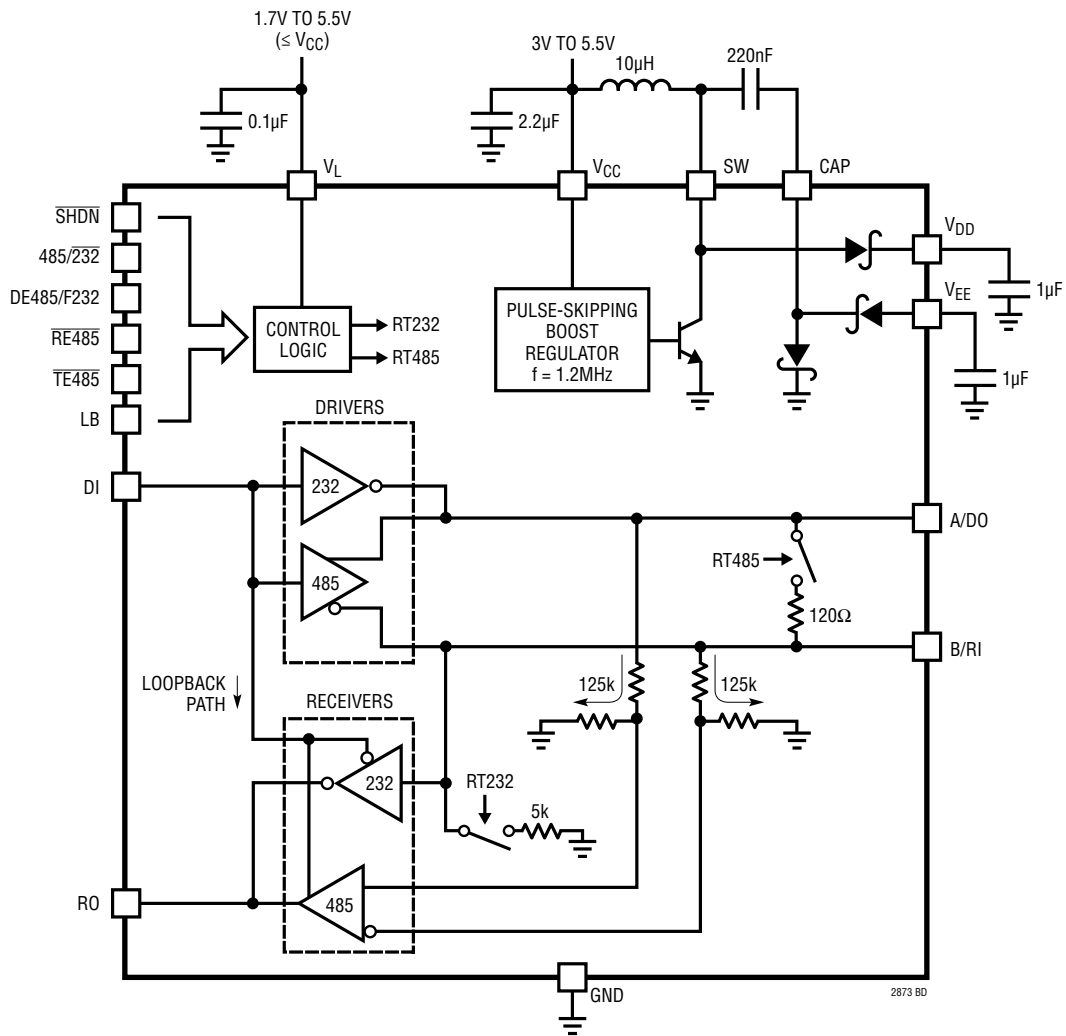

TEST CIRCUITS

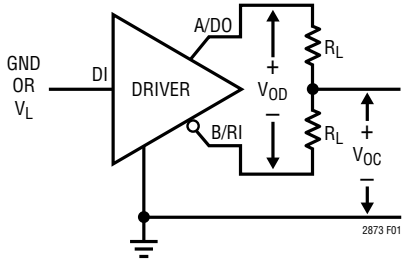

Figure 1. RS485 Driver DC Characteristics

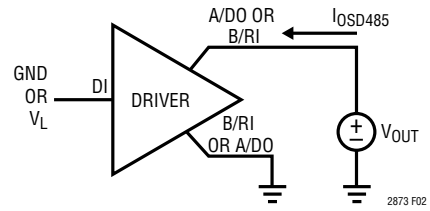

Figure 2. RS485 Driver Output Current

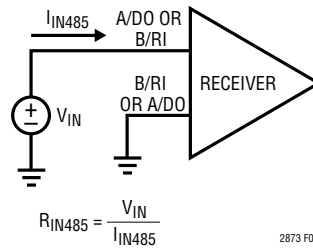

Figure 3. RS485 Receiver Input Current and Resistance

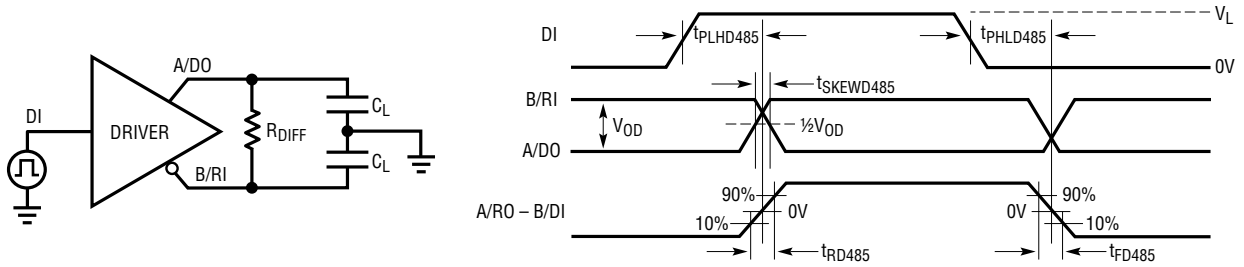
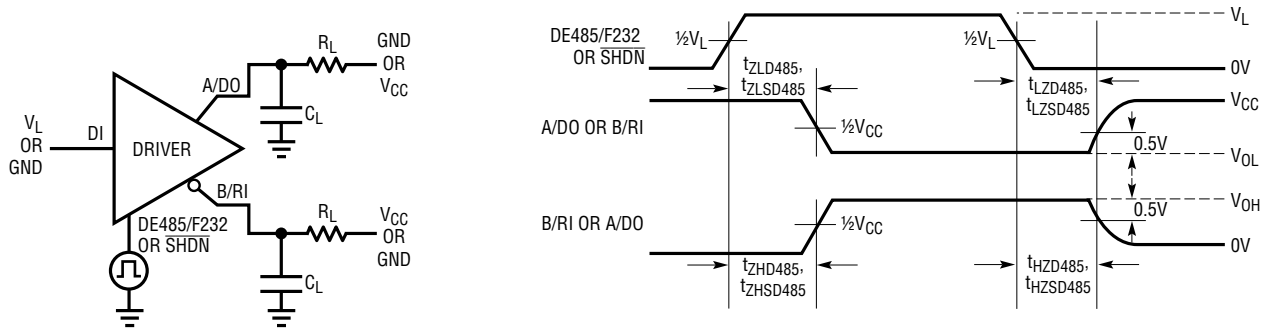

Figure 4. RS485 Driver Timing Measurement

TEST CIRCUITS



2873 F05

Figure 5. RS485 Driver Enable and Disable Timing Measurements

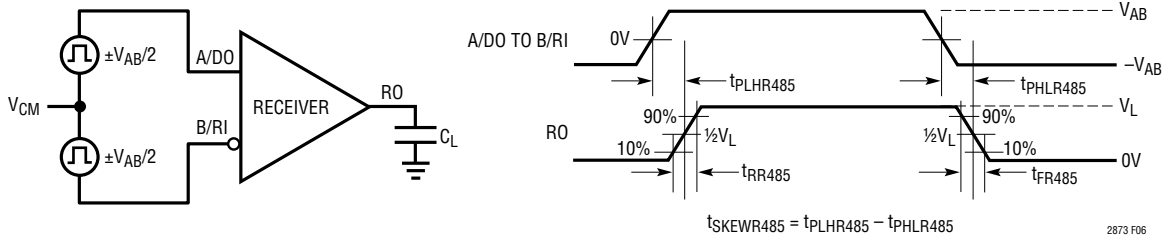

2873 F06

Figure 6. RS485 Receiver Propagation Delay Measurements

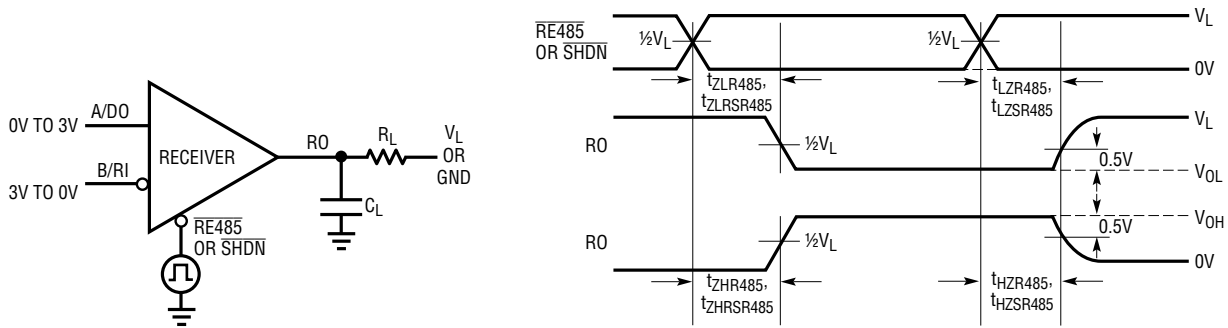

2873 F07

Figure 7. RS485 Receiver Enable and Disable Timing Measurements

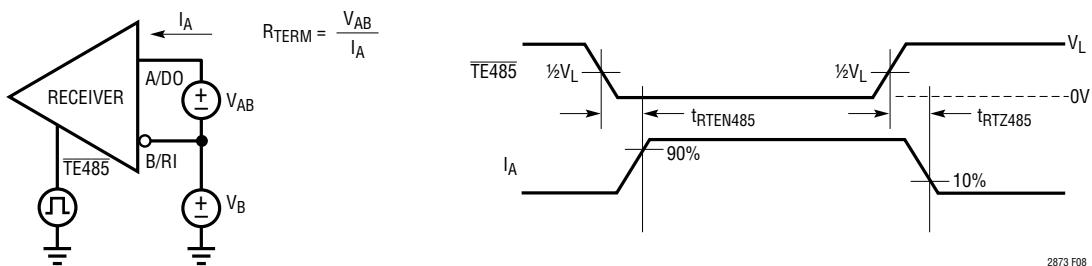

2873 F08

Figure 8. RS485 Termination Resistance and Timing Measurements

TEST CIRCUITS

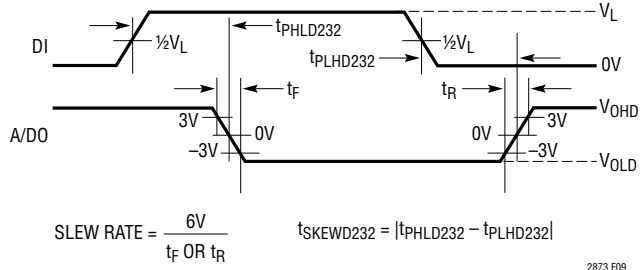
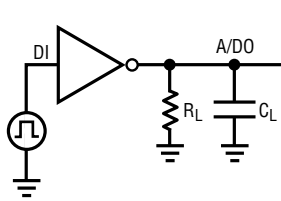

Figure 9. RS232 Driver Timing and Slew Rate Measurements

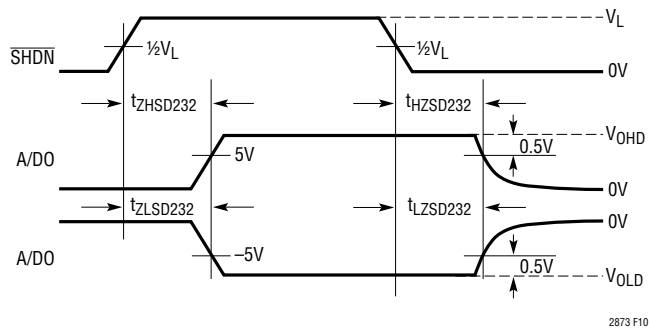
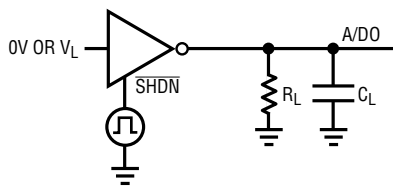

Figure 10. RS232 Driver Enable and Disable Times

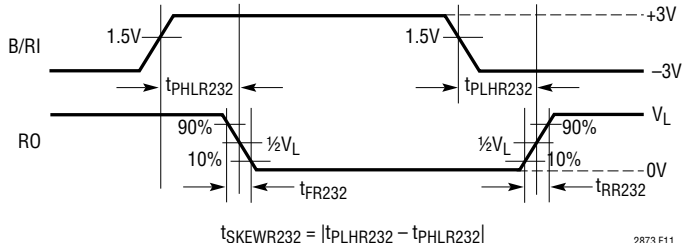
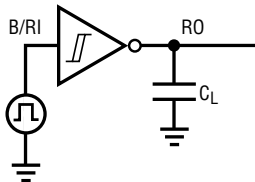

Figure 11. RS232 Receiver Timing Measurements

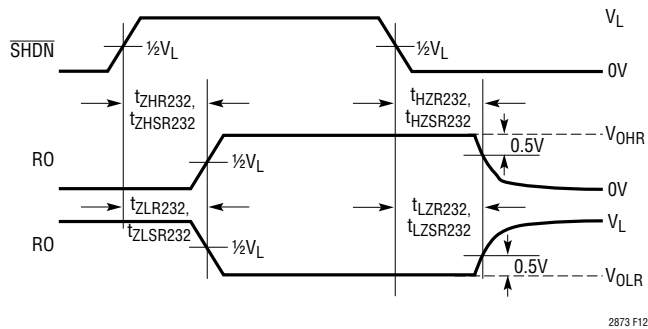
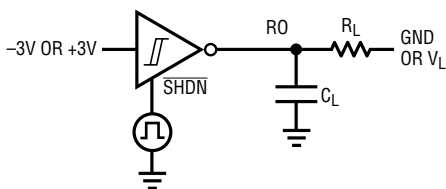

Figure 12. RS232 Receiver Enable and Disable Times

TEST CIRCUITS

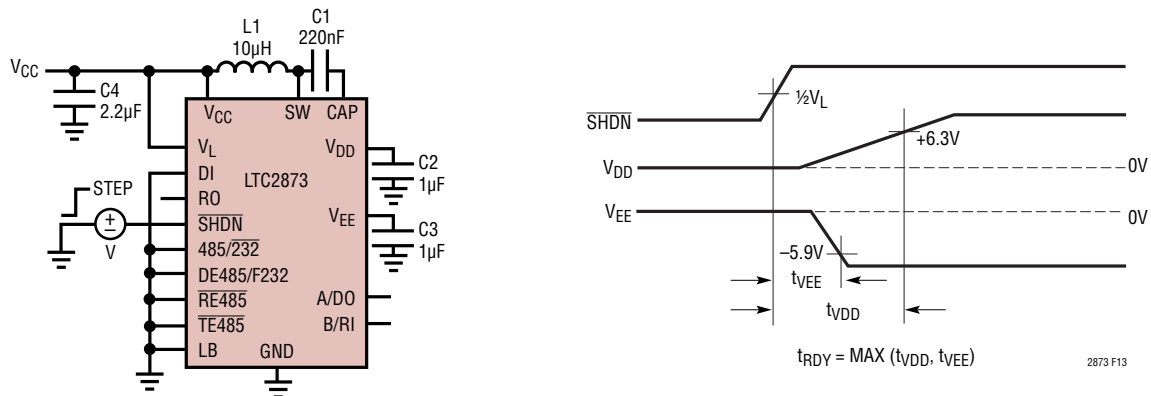

Figure 13. Timing Coming Out of Shutdown Mode

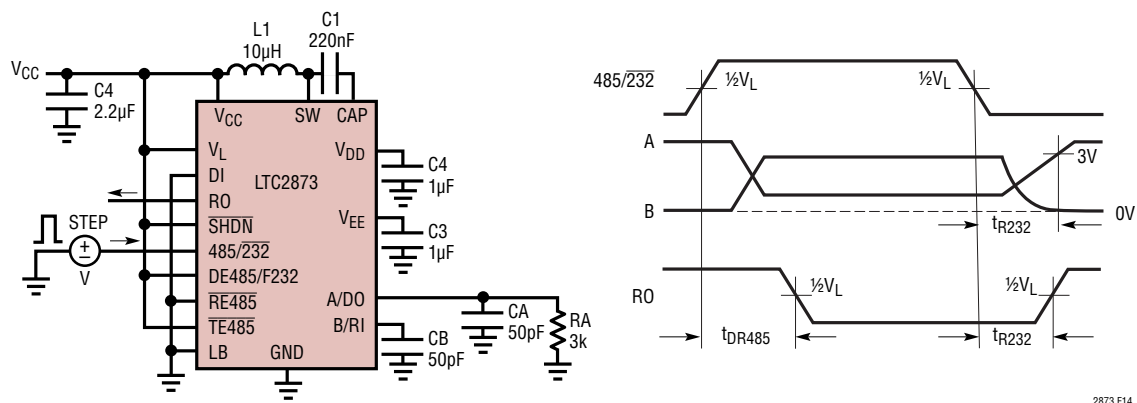

Figure 14. Mode Change Timing

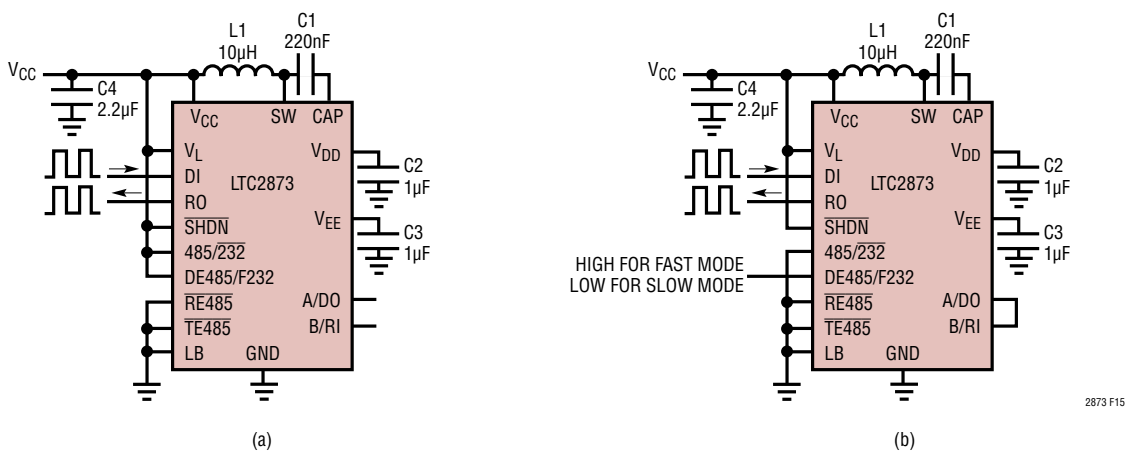

Figure 15. Testing Max Data Rate for (a) RS485 and (b) RS232. Observe that Data In Matches Data Out

FUNCTION TABLE

KEY: 0 = Logic Low; 1 = Logic High; RX = Receiver; TX = Driver; ● = Enabled; LB = Receiver Output is the Data Input Signal (Looped Back)

| INPUTS | | | | | | RESULT | | | | | | | |
|--------|---------|-------|----------------|-------|----|-------------|----------------|-------|----|-------|----|------|---|
| SHDN | 485/232 | RE485 | DE485/ F232 | TE485 | LB | MODE | DC/DC CONV. | RS232 | | RS485 | | | |
| | | | | | | | | RX | TX | RX | TX | TERM | |
| 0 | X | X | X | X | X | SHUTDOWN | | | | | | | |
| 1 | 0 | X | 0 | X | 0 | RS232 SLOW | ● | ● | ● | | | | |
| 1 | 0 | X | 0 | X | 1 | | ● | LB | ● | | | | |
| 1 | 0 | X | 1 | X | 0 | RS232 FAST | ● | ● | ● | | | | |
| 1 | 0 | X | 1 | X | 1 | | ● | LB | ● | | | | |
| 1 | 1 | 1 | 0 | 1 | X | RS485 READY | ● | | | | | | |
| 1 | 1 | 1 | 0 | 0 | X | | ● | | | | | | ● |
| 1 | 1 | 0 | 0 | 0 | 0 | RS485 | ● | | | ● | | ● | |
| 1 | 1 | 0 | 0 | 0 | 1 | | ● | | | LB | | | ● |
| 1 | 1 | 0 | 0 | 1 | 0 | | ● | | | ● | | | |
| 1 | 1 | 0 | 0 | 1 | 1 | | ● | | | LB | | | |
| 1 | 1 | 0 | 1 | 0 | 0 | | ● | | | ● | ● | | ● |
| 1 | 1 | 0 | 1 | 0 | 1 | | ● | | | LB | ● | ● | ● |
| 1 | 1 | 0 | 1 | 1 | 0 | | ● | | | ● | ● | | |
| 1 | 1 | 0 | 1 | 1 | 1 | | ● | | | LB | ● | | |
| 1 | 1 | 1 | 1 | 0 | X | | ● | | | | ● | | ● |
| 1 | 1 | 1 | 1 | 1 | X | | ● | | | | ● | | |

APPLICATIONS INFORMATION

The LTC2873 is a flexible multiprotocol transceiver supporting RS485/RS422 and RS232 protocols.

This device can be powered from a single 3V to 5.5V supply with optional logic interface supply as low as 1.7V. An integrated DC/DC converter provides the positive and negative supply rails needed for RS232 operation. Automatically selected integrated termination resistors for both RS232 and RS485 protocols are included, eliminating the need for external termination components and switching relays. A logic loopback control is included for self-test and debug.

The LTC2873 bus interface is a single two-pin port that can be configured as either an RS232 driver/receiver pair or a differential RS485 (and RS422) transceiver depending on the state of the 485/232 pin. In RS485 mode, the driver and receiver can be enabled independently with the DE485/F232 and RE485 pins, or by tying these signals together, a single control selects transmit or receive modes. A 120Ω termination resistor is automatically engaged between pins A/DO and B/RI in RS485 mode if TE485 is low.

When the LTC2873 is in RS232 mode, the RS232 driver and receivers are both active and a 5k resistor is engaged at the receiver input to ground. The slew rate in RS232 mode can be set to support 1Mbps or 250kbps operation using the DE485/F232 pin.

The LTC2873 features rugged operation with ESD ratings of $\pm 26\text{kV}$ HBM on the RS232 and RS485 receiver inputs and driver outputs, both unpowered and powered. All other pins offer protection exceeding $\pm 4\text{kV}$.

DC/DC Converter

The on-chip DC/DC converter operates from the V_{CC} input, generating a 7.0V V_{DD} supply and a charge pumped -6.3V V_{EE} supply, as shown in Figure 16. V_{DD} and V_{EE} power the output stage of the RS232 drivers and are regulated to levels that guarantee greater than $\pm 5\text{V}$ output swing.

The DC/DC converter requires a 10μH inductor (L1) and a bypass capacitor (C4) of 2.2μF. The charge pump capacitor (C1) is 220nF and the storage capacitors (C2 and C3) are 1μF. Locate C1 – C4 close to their associated pins shown in Figure 16. Refer to Layout Considerations section for guidance on circuit board layout.

Bypass capacitor C5 on the logic supply pin can be omitted if V_L is connected to V_{CC} . See the V_L Logic Supply section for more details about the V_L logic supply.

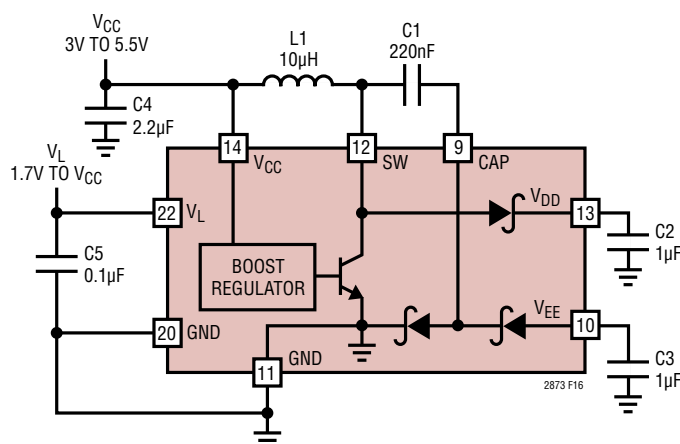

NOTE: NOT ALL PINS SHOWN. IN THE CASE OF DUPLICATE PINS FOR V_{CC} , GND, AND V_{EE} , EXTERNAL COMPONENTS SHOULD BE POSITIONED CLOSEST TO THE NUMBERED PIN SHOWN ABOVE.

Figure 16. Simplified DC/DC Converter with Required External Components

APPLICATIONS INFORMATION

Powering Multiple Devices

Multiple LTC2873 devices can be powered using the boost regulator from only one of the devices, requiring only one inductor (L1) and charge pump cap (C1). Since the RS232 drivers provide the primary load to the circuit, the following guidelines apply:

1. No more than four RS232 drivers can be supplied from a single device.
2. If more than two RS232 drivers are being supplied from a single device, then the inductor, L1, must be increased to 22 μ H and the charge pump cap, C1, must be increased to 470nH, and V_{DD} and V_{EE} bypass caps must be increased to 2.2 μ F.
3. Ground the SW pin on devices with inactive boost converters.
4. Connect CAP pins together for all devices.
5. Connect V_{EE} pins together for all devices.
6. Connect V_{DD} pins together for all devices.

Figure 32 shows an example of how to connect four devices.

Inductor Selection

A 10 μ H or 22 μ H ($\pm 20\%$) inductor with a saturation current (I_{SAT}) rating of at least 220mA and a DCR (copper wire resistance) of less than 1.3 Ω is required. Some very small inductors meeting these requirements are listed in Table 1.

Capacitor Selection

The small size of ceramic capacitors makes them ideal for the LTC2873. Use X5R or X7R dielectric types; their ESR is low and they retain their capacitance over relatively

wide voltage and temperature ranges. Use a voltage rating of at least 10V.

Running with External V_{DD} and V_{EE} Supplies

The inductor and charge pump cap, C1, can be omitted only if V_{DD} and V_{EE} are externally supplied. Bypass caps on V_{DD} and V_{EE} must remain in place. In this circumstance, ground the SW pin and float the CAP pin. External supplies must not exceed the absolute maximum levels of $\pm 7.5V$. Ideal supply levels are 7.2V and $-6.5V$ as these are each just wider than the regulation points of 7.0V and $-6.3V$ so the internal feedback is satisfied and the switching stops. Lower voltages can be used even at $-6V$ and $+6V$ but the internal boost regulator will be switching. This may cause some switching noise but will not harm the part. V_{DD} and V_{EE} supplies must be present for proper operation in RS232 mode and in RS485 mode when the termination is enabled. It is okay to run the LTC2873 in RS485 mode with internal termination disabled ($\overline{TE485}$ high), when V_{DD} and V_{EE} are not present or fully settled.

Inrush Current and Supply Overshoot Precaution

In certain applications, fast supply slew rates are generated when power is connected. If the V_{CC} voltage is greater than 4.5V and its rise time is faster than 10 μ s, the pins V_{DD} and SW can exceed their absolute maximum values during start-up. When supply voltage is applied to V_{CC} , the voltage difference between V_{CC} and V_{DD} generates inrush current flowing through inductor L1 and capacitors C1 and C2. The peak inrush current must not exceed 2A. To avoid this condition, add a 1 Ω resistor as shown in Figure 17. This precaution is not relevant for supply voltages below 4.5V or rise times longer than 10 μ s.

Table 1. Recommended Inductors

| PART NUMBER | L (μ H) | I_{SAT} (mA) | MAX DCR (Ω) | SIZE (mm) | MANUFACTURER |
|---------------------|--------------|----------------|----------------------|-----------------|--------------------------------|
| 74479888310 | 10 | 250 | 0.5 | 2.5 × 2 × 1 | Würth Elektronik |
| CBC2016T100K (or M) | 10 | 380 | 1.07 | 2 × 1.6 × 1.6 | Taiyo Yuden www.t-yuden.com |
| CBC2518T220K (or M) | 22 | 320 | 1.0 | 2.5 × 1.8 × 1.8 | |
| BRC2016T220K (or M) | 22 | 310 | 1.3 | 2 × 1.6 × 1.6 | |
| LQH32CN220K53 | 22 | 250 | 0.92 | 3.2 × 2.5 × 1.6 | Murata www.murata.com |

APPLICATIONS INFORMATION

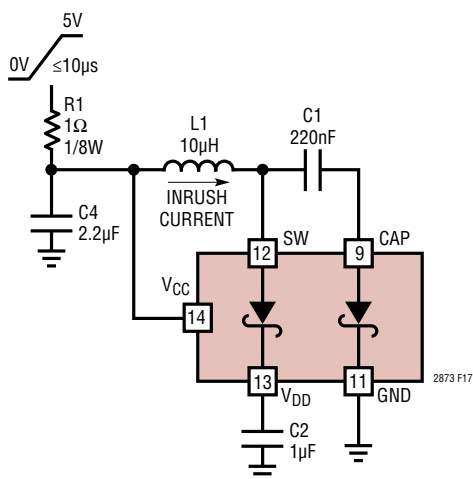

Figure 17. Supply Current Overshoot Protection for Input Supplies of 4.5V or Higher and Rise Times Faster Than 10μs

V_L Logic Supply and Logic Pins

A separate logic supply pin V_L allows the LTC2873 to interface with any logic signal from 1.7V to 5.5V. All logic I/Os use V_L as their high supply. For proper operation, V_L should not be greater than V_{CC}. During power-up, if V_L is higher than V_{CC}, the device will not be damaged, but behavior of the device is not guaranteed. In particular, supply currents can be somewhat higher than specified. If V_L is not connected to V_{CC}, bypass V_L with a 0.1μF capacitor to GND.

RS232 and RS485 driver outputs are undriven and the RS485 termination resistors are disabled when V_L or V_{CC} is grounded or V_{CC} is disconnected.

Although all logic input pins reference V_L as their high supply, they can be driven up to 7V, independent of V_L and V_{CC}, with the exception of SHDN, which must not exceed V_L by more than 0.3V. Logic input pins do not have internal biasing devices to pull them up or down. They must be driven high or low to establish valid logic levels; do not float.

RS485 Driver

The RS485 driver provides full RS485/RS422 compatibility. When enabled, if DI is high, (A/DO to B/RI) is positive. With the driver disabled, the A/DO and B/RI resistance is

greater than 96kΩ (typically 125kΩ) to ground over the entire common mode range of –7V to +12V. This resistance is actually the RS485 receiver input resistance, which is connected to the same pins.

RS232 Driver with Speed Selection

The RS232 driver provides full compatibility with the TIA/EIA-232-F (RS232) specification. When in RS232 mode, the driver is automatically enabled. Like all RS232 drivers, it is inverting, so that when the input, DI, is low, the output, A/DO, is high, and vice-versa.

The RS232 driver slew rate can be selected to support data rates of up to 250kbps or 1Mbps with the DE485/F232 pin. Since RS232 signals are single ended and large amplitude, compared with RS485, radiated emissions may be a concern. To minimize emissions, the speed selection should be set to Slow mode by setting DE485/F232 low for data rates of 250kbps or less. For higher data rates, up to 1Mbps, Fast mode must be engaged by setting DE485/F232 high. Even in Fast mode the driver transitions are slew controlled to minimize emissions. See "Typical Performance Characteristics" section for examples of the waveforms.

Driver Overvoltage and Overcurrent Protection

The RS232 and RS485 driver outputs are protected from short circuits to any voltage within the absolute maximum range of ±15V. The maximum current in this condition is 90mA for the RS232 driver and 250mA for the RS485 driver. If the RS485 driver output is shorted to a voltage greater than V_{CC}, when it is active, positive current of about 100mA can flow from the driver output back to V_{CC}. If the system power supply or loading cannot sink this excess current, clamp V_{CC} to GND with a Zener diode (e.g., 5.6V, 1W, 1N4734) to prevent an overvoltage condition on V_{CC}.

All devices also feature thermal shutdown protection that disables the drivers, receivers, and RS485 terminators in case of excessive power dissipation during momentary overload conditions. Overtemperature protection activates at a junction temperature exceeding about 165°C (not tested in production). NOTE: Continuous operation above the specified maximum operating junction temperature may result in device degradation or failure.

TYPICAL APPLICATIONS

RS485 Balanced Receiver with Full Failsafe Operation

The LTC2873 RS485 receiver has a differential threshold voltage that is about +110mV for signals that are rising and -110mV for signals that are falling, as illustrated in Figure 18. If a differential input signal lingers in the window between these thresholds for more than about 0.7 μ s, the rising threshold changes from +110mV to -70mV, while the falling threshold remains at -110mV. Thus, differential inputs that are shorted, open, or terminated but not driven for more than 0.7 μ s produce a high on the receiver output, indicating a failsafe condition.

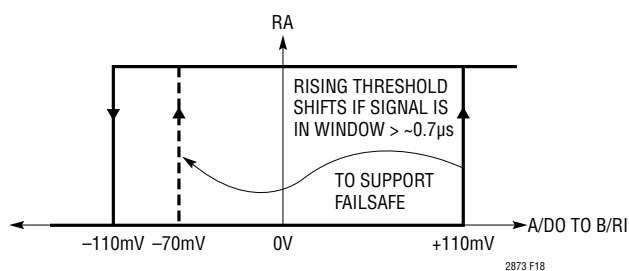

Figure 18. RS485 Receiver Input Threshold Characteristics with Typical Values Shown

The benefit of this dual threshold architecture is that it supports full failsafe operation yet offers a balanced threshold, centered on 0V, for normal data signals. This balance preserves duty cycle for small input signals with heavily slewed edges, typical of what might be seen at the end of a very long cable. This performance is highlighted in Figure 19, where a signal is driven through 4000ft of CAT-5e cable at 3Mbps. Even though the differential signal peaks are at only 200mV and is heavily slewed, the output maintains a nearly perfect signal with almost no duty cycle distortion.

An additional benefit of the balanced architecture is excellent noise immunity due to the wide effective differential input signal hysteresis of 220mV for signals transitioning through the window region in less than 0.7 μ s. Increasingly slower signals will have increasingly less effective hysteresis, limited by the DC failsafe hysteresis of about 40mV.

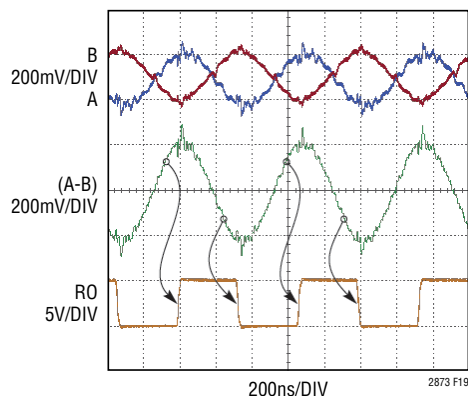

Figure 19. A 3Mbps Signal Driven Down 4000ft of CAT-5e Cable. Top Traces: Received Signals After Transmission Through Cable; Middle Trace: Math Showing Differences of Top Two Signals; Bottom Trace: Receiver Output

RS485 Biasing Network Not Required

RS485 networks are often biased with a resistive divider to generate a differential voltage of ≥ 200 mV on the data lines, which establishes a logic-high state when all the transmitters on the network are disabled. The values of the biasing resistors depend on the number and type of transceivers on the line and the number and value of terminating resistors. Therefore, the values of the biasing resistors must be customized to each specific network installation, and may change if nodes are added to or removed from the network.

The internal failsafe feature of the LTC2873 eliminates the need for external network biasing resistors provided they are used in a network of transceivers with similar internal failsafe features. This also allows the network to support a high number of nodes, up to 256, by eliminating the bias resistor loading. The LTC2873 transceiver operates correctly on biased, unbiased, or under-biased networks.

If a twisted pair has unbalanced capacitance from its two conductors to AC ground, common mode transients can translate into small differential voltages. If the common mode event is large and fast enough, the resulting differential voltage can cause a receiver, whose inputs are

APPLICATIONS INFORMATION

undriven, to change state momentarily. In these extreme conditions, high quality shielded cable is recommended. If necessary, biasing resistors can be used on the bus to pull the resting signal farther from the receivers failsafe threshold.

Receiver Outputs

The RS232 and RS485 receiver outputs are internally driven high (to V_L) or low (to GND) with no external pull up needed. When the receivers are disabled the output pin becomes Hi-Z with leakage of less than $\pm 5\mu\text{A}$ for voltages within the V_L supply range.

RS485 Receiver Input Resistance

In RS485 mode, the RS485 receiver input resistance from A/DO or B/RI to GND is $125\text{k}\Omega$ (typical) when the integrated termination is disabled. This permits up to a total of 256 receivers per system without exceeding the RS485 receiver loading specification. The input resistance of the receiver is unaffected by enabling/disabling the receiver or whether the part is in loopback mode, or unpowered. The equivalent input resistance looking into the RS485 receiver pins is shown in Figure 20.

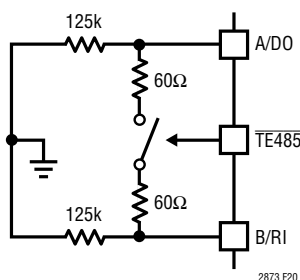

Figure 20. Equivalent RS485 Receiver Input Resistance Into A/DO and B/RI

RS232 Receiver Input Resistance

In RS232 mode, the receiver input resistance on the B/RI pin is always $5\text{k}\Omega$ to GND. In any other mode, this resistor is switched out. The 120Ω RS485 termination resistor between pins A/DO and B/RI is never engaged in RS232 mode, regardless of the state of $\overline{\text{TE485}}$ pin.

Selectable RS485 Termination

Proper cable termination is important for good signal fidelity. When the cable is not terminated with its characteristic impedance, reflections cause waveform distortion.

The LTC2873 offers an integrated switchable 120Ω termination resistor between pins A/DO and B/RI.

This termination supports communication over a twisted pair cable with characteristic impedance of 120Ω or 100Ω , including CAT-5 cables. It has the advantage of being able to easily change, through logic control, the proper line termination for correct operation when configuring transceiver networks. Termination should be enabled on transceivers positioned at both ends of the network bus only. However, the driving end of a line does not need to be terminated. By turning off termination at the driver, the reduced load results in less power dissipation and a larger signal swing on the bus. $\overline{\text{TE485}}$ can be tied to DE485/F232 to logically switch the termination on only when the driver is inactive if the termination enable/disable delays can be tolerated in the overall system level timing. If the delays are not acceptable, tie $\overline{\text{TE485}}$ low to enable termination for all modes of RS485 operation, whether driving or receiving.

The termination resistance is maintained over the entire RS485 common mode range of -7V to 12V as shown in Figure 21. The voltage across pins with the terminating resistor enabled should not exceed 6V as indicated in the Absolute Maximum Ratings table.

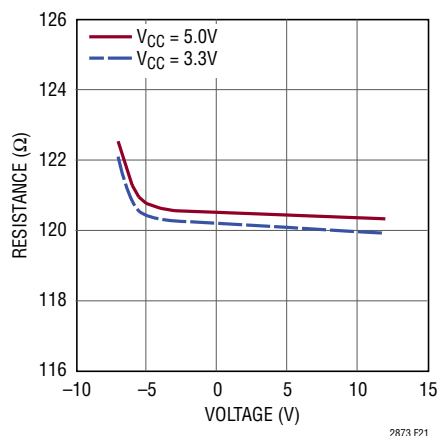

Figure 21. Typical Resistance of the Enabled RS485 Terminator vs Common Mode Voltage of A/DO and B/RI

APPLICATIONS INFORMATION

Logic Loopback

A loopback mode connects the driver inputs to the receiver outputs (non-inverting) providing an echo for self-test. This applies to both RS232 and RS485 transceivers. Loopback mode is entered when the LB pin is set to a logic-high and the relevant receiver is enabled. The RS485 driver output can be disabled in loopback mode if DE485/F232 is held low, or functions normally with DE485/F232 high. The RS232 driver output cannot be disabled when loopback is engaged in RS232 mode, and functions normally. The loopback signal traverses a path from the logic input circuit at DI to the logic output at RO and does not exercise the entire driver or receiver circuit. Thus loopback, alone, is not a sufficient test to ensure full functionality of the LTC2873. Loopback does not affect the operation of the termination resistors.

Robust ESD Protection

The LTC2873 features exceptionally robust ESD protection. The transceiver interface pins (A and B) are protected to $\pm 26\text{kV}$ human body model with respect to GND, V_{CC} , or V_L without latchup or damage. This protection holds whether the device is unpowered or powered in any mode of operation. To note, $\pm 26\text{kV}$ is an upper limit of the tester—the actual device protection level is higher. Every other pin on the device is protected to $\pm 4\text{kV}$ ESD (HBM) for all-around robustness. Figure 22 shows the LTC2873 being struck repeatedly with 26kV of ESD energy (air gap discharge) during operation with no damage or circuit latchup.

RS485 Cable Length vs Data Rate

Many factors contribute to the maximum cable length that can be used for RS485 or RS422 communication, including driver transition times, receiver threshold, duty

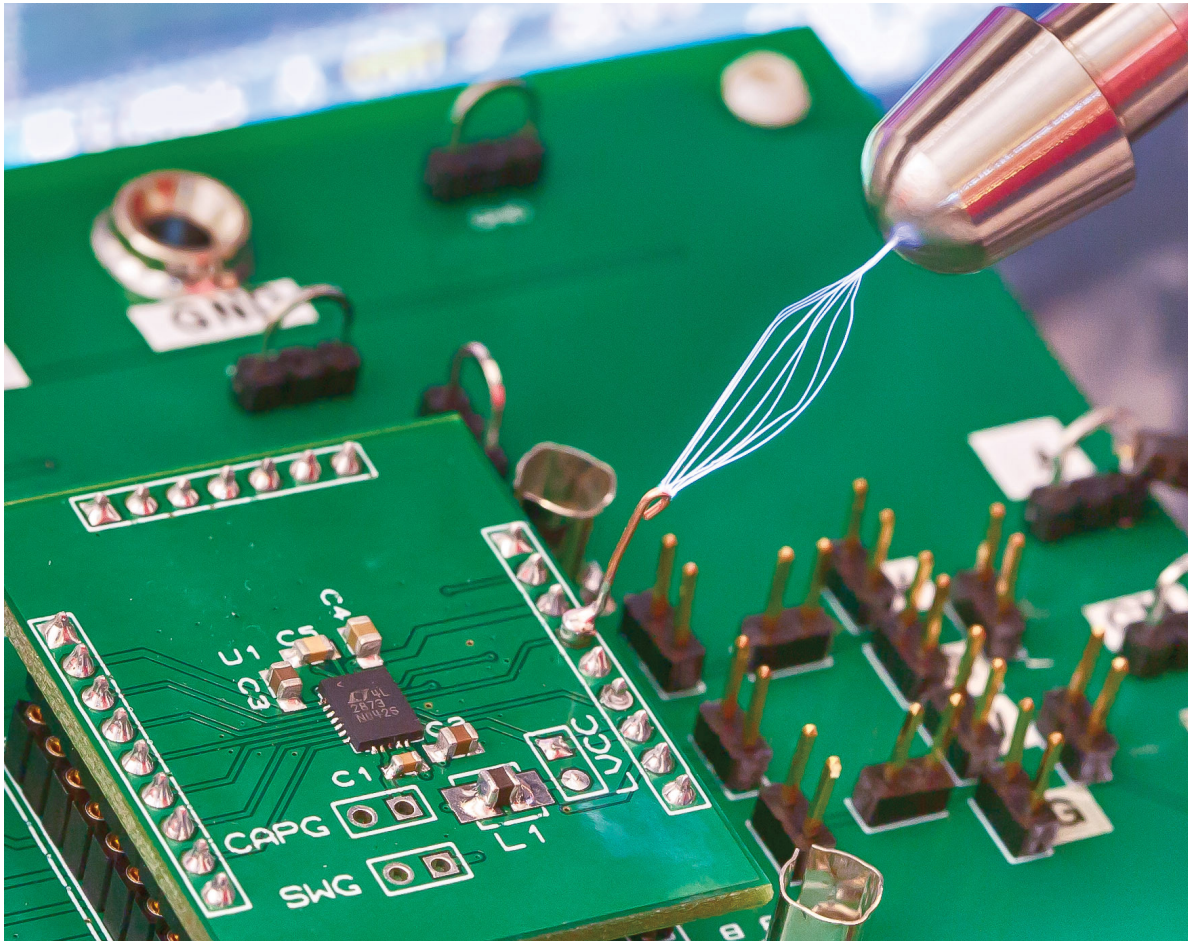

Figure 22. LTC2873 Struck Repeatedly with 26kV of ESD Energy While Operating. No Damage or Circuit Latchup Occurs

REV B

APPLICATIONS INFORMATION

cycle distortion, cable properties and data rate. A typical curve of cable length versus maximum data rate is shown in Figure 23. Various regions of this curve reflect different performance limiting factors in data transmission.

At frequencies below 100kbps, the maximum cable length is determined by DC resistance in the cable. In this example, a cable longer than 4000ft will attenuate the signal at the far end to less than what can be reliably detected by the receiver.

For data rates above 100kbps, the capacitive and inductive properties of the cable begin to dominate this relationship. The attenuation of the cable is frequency and length dependent, resulting in increased rise and fall times at the far end of the cable. At high data rates or long cable lengths, these transition times become a significant part of the signal bit time. Jitter and inter symbol interference aggravate this so that the time window for capturing valid data at the receiver becomes impossibly small.

The boundary at 20Mbps in Figure 23 represents the guaranteed maximum operating rate of the LTC2873. The dashed vertical line at 10Mbps represents the specified maximum data rate in the RS485 standard. This boundary is not a limit, but reflects the maximum data rate that the specification was written for. It should be emphasized that the plot in Figure 23 shows a typical relation between maximum data rate and cable length. Results with the LTC2873 will vary, depending on cable properties such as conductor gauge, characteristic impedance, insulation material, and solid versus stranded conductors.

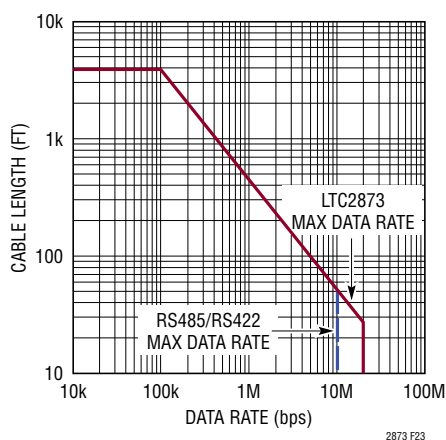

**Figure 23. Cable Length vs Data Rate
(RS485/RS422 Standard Shown in Vertical Dashed Line)**

Layout Considerations

All V_{CC} pins must be connected together and all ground pins must be connected together on the PC board with very low impedance traces or dedicated planes. A 2.2 μ F, or larger, bypass capacitor should be placed less than 7mm away from V_{CC} Pin 14. This V_{CC} pin, as well as GND Pin 11, mainly service the DC/DC converter. Additional bypass capacitors of 0.1 μ F or larger, can be added from V_{CC} pin 18 to ground pin 16 if the traces back to the 2.2 μ F capacitor are indirect or narrow. These V_{CC} and ground pins mainly service the RS485 driver. Table 2 summarizes the bypass capacitor requirements. The capacitors listed in the table should be placed closest to their respective supply and ground pin.

Table 2. Bypass Capacitor Requirements

| CAPACITOR (μ F) | SUPPLY (PIN) | RETURN (PIN) | COMMENT |
|----------------------|---------------|--------------|-----------|
| 2.2 | V_{CC} (14) | GND (11) | Required |
| 1.0 | V_{DD} (13) | GND (11) | Required |
| 1.0 | V_{EE} (10) | GND (11) | Required |
| 0.1 | V_L (22) | GND (20) | Required* |
| 0.1 | V_{CC} (18) | GND (16) | Optional |
| 0.1 | V_{CC} (21) | GND (20) | Optional |

*If V_L is not connected to V_{CC} .

Place the charge pump capacitor, C1, directly adjacent to the SW and CAP pins, with no more than one centimeter of total trace length to maintain low inductance. Close placement of the inductor, L1, is of secondary importance compared to the placement of C1 but should include no more than two centimeters of total trace length.

The PC board traces connected to high speed bus signals A/DO and B/RI should be symmetrical and as short as possible to minimize capacitive imbalance and to maintain good differential signal integrity. To minimize capacitive loading effects, the differential signals should be separated by more than the width of a trace and should not be routed on top of each other if they are on different signal planes.

Care should be taken to route outputs away from any sensitive inputs to reduce feedback effects that might cause noise, jitter, or even oscillations. For example, DI, A/DO, and B/RI should not be routed near RO.

TYPICAL APPLICATIONS

Supply Connections and External Components Necessary for Operation Are Not Shown.
 H = Logic High; L = Logic Low, X = Don't Care (Logic High or Logic Low)

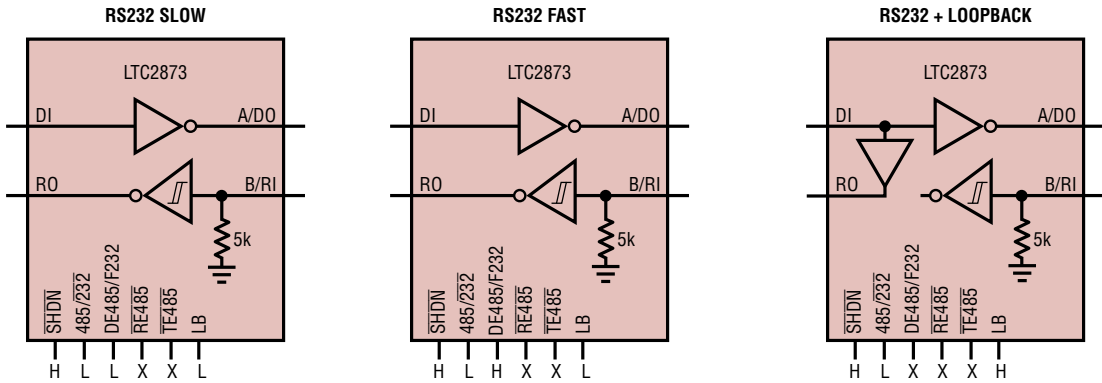

2873 F24

Figure 24. RS232 Configurations

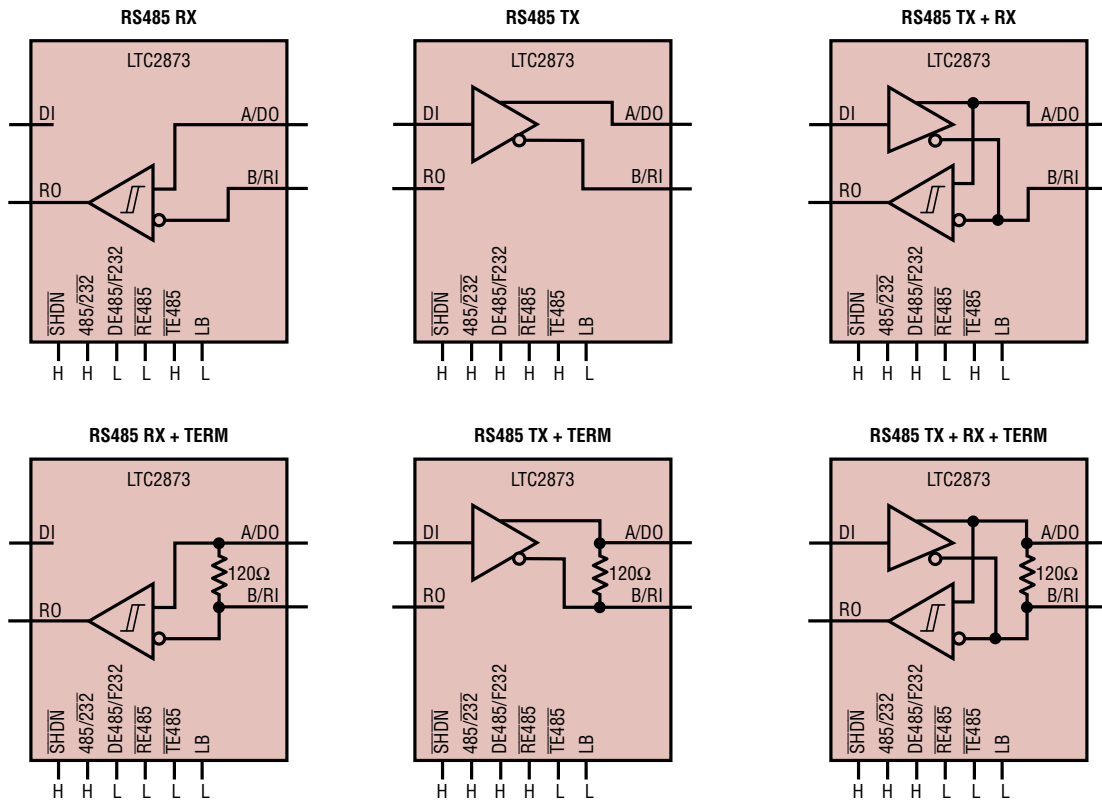

2873 F25

Figure 25. RS485 Configurations

TYPICAL APPLICATIONS

Supply Connections and External Components Necessary for Operation Are Not Shown.
 H = Logic High; L = Logic Low, X = Don't Care (Logic High or Logic Low)

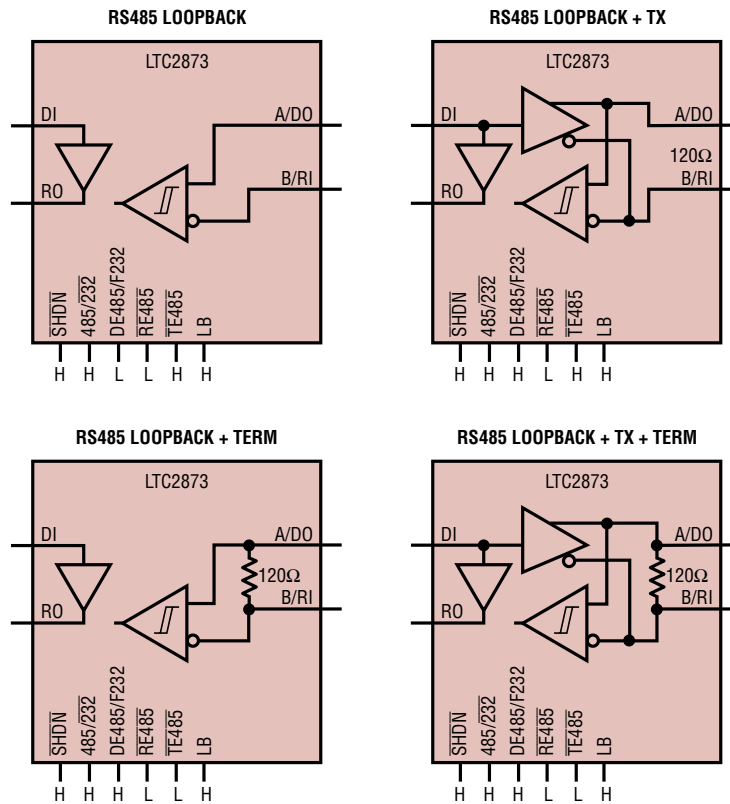

2873 F26

Figure 26. RS485 + Loopback Configurations

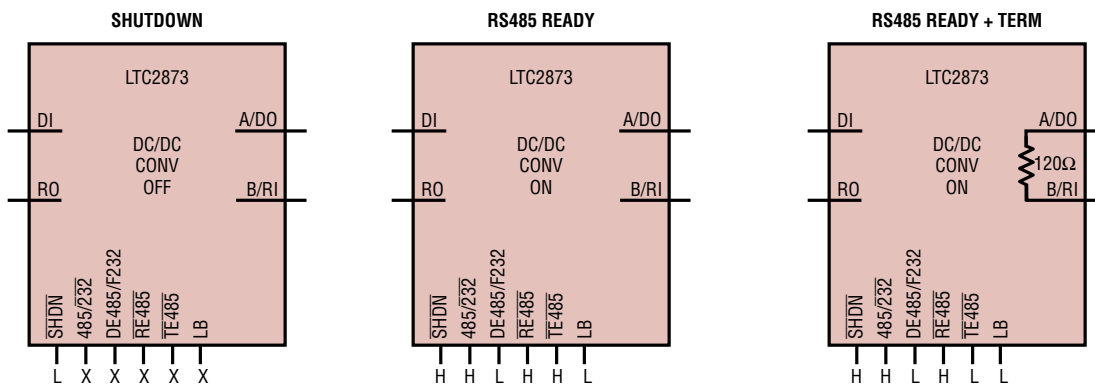

2873 F27

Figure 27. Shutdown, RS485 Ready and RS485 Ready + Term Configurations

TYPICAL APPLICATIONS

Supply Connections and External Components Necessary for Operation Are Not Shown.
 H = Logic High; L = Logic Low, X = Don't Care (Logic High or Logic Low)

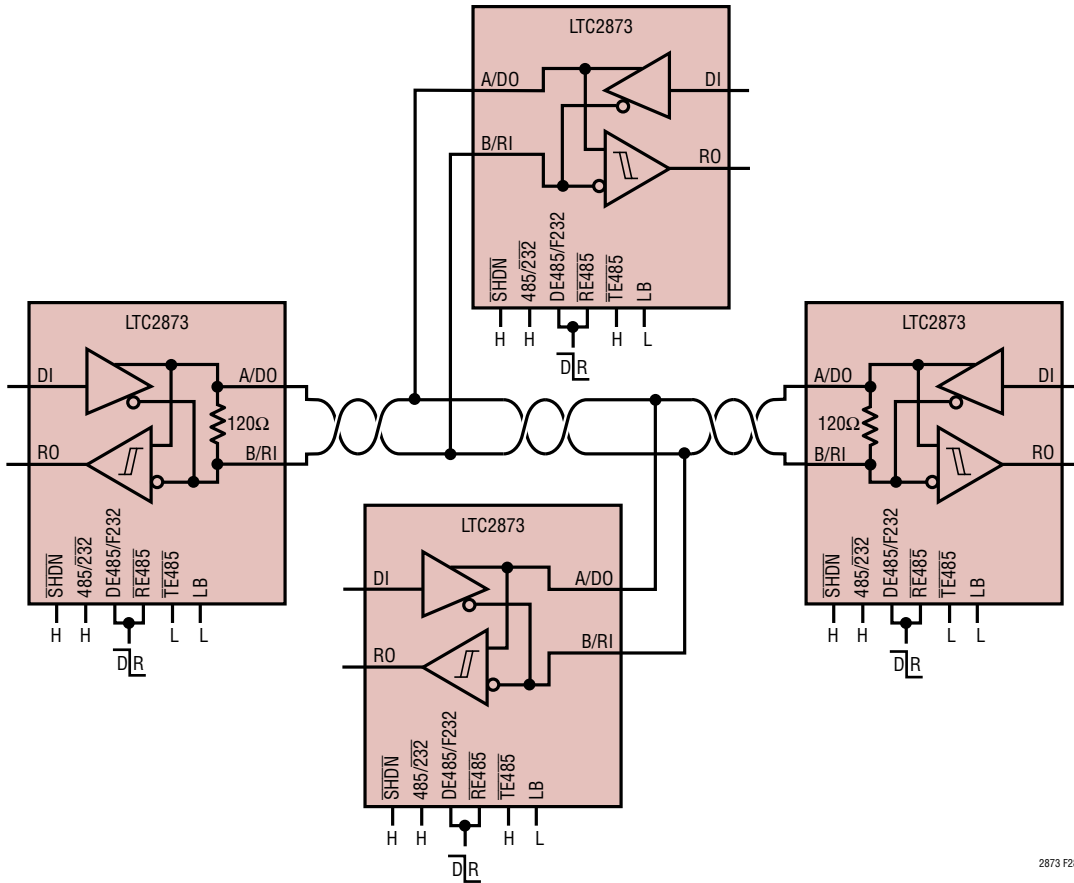

Figure 28. Typical RS485 Half Duplex Network

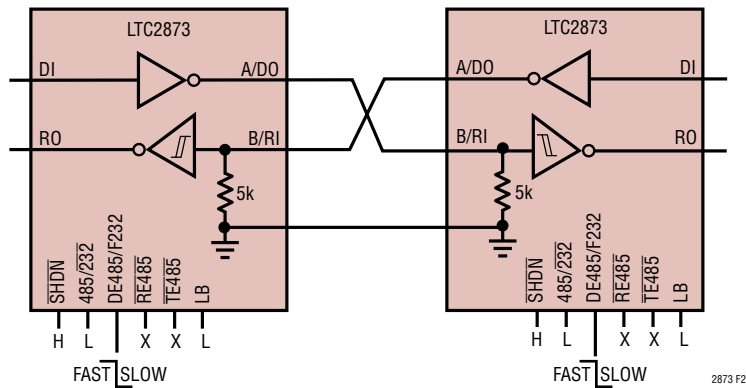

Figure 29. Typical RS232 Communications Link

TYPICAL APPLICATIONS

Supply Connections and External Components Necessary for Operation Are Not Shown.
 H = Logic High; L = Logic Low, X = Don't Care (Logic High or Logic Low)

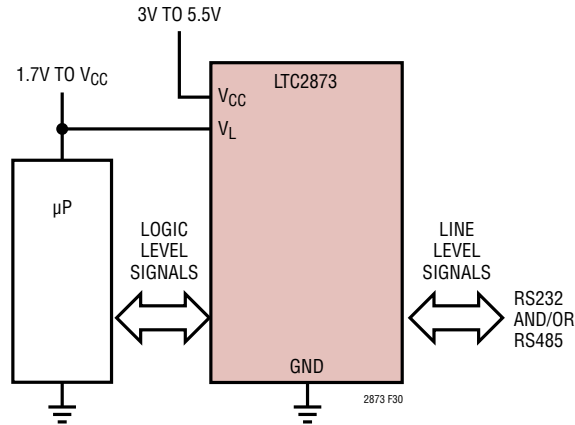

Figure 30. Low Voltage Microprocessor Interface

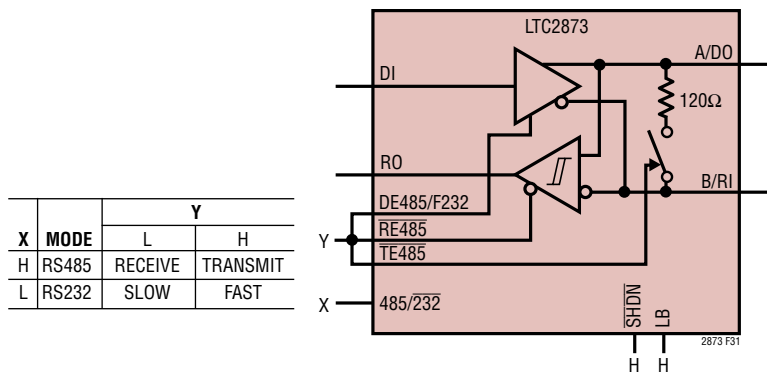

Figure 31. Receiver-Only RS485 Termination for Power Savings

TYPICAL APPLICATIONS

| APPLICATION | NUMBER OF LTC2873 DEVICES | L1 | C1 | C2 | C3 | MINIMUM C4-X |
|--------------------|---------------------------|------------|-------|-------------|-------------|--------------|
| SINGLE TRANSCEIVER | 1 | 10 μ H | 220nF | 1 μ F | 1 μ F | 2.2 μ F |
| DUAL TRANSCEIVER | 2 | 10 μ H | 220nF | 1 μ F | 1 μ F | 2.2 μ F |
| TRIPLE TRANSCEIVER | 3 | 22 μ H | 470nF | 2.2 μ F | 2.2 μ F | 1 μ F |
| QUAD TRANSCEIVER | 4 | 22 μ H | 470nF | 2.2 μ F | 2.2 μ F | 1 μ F |

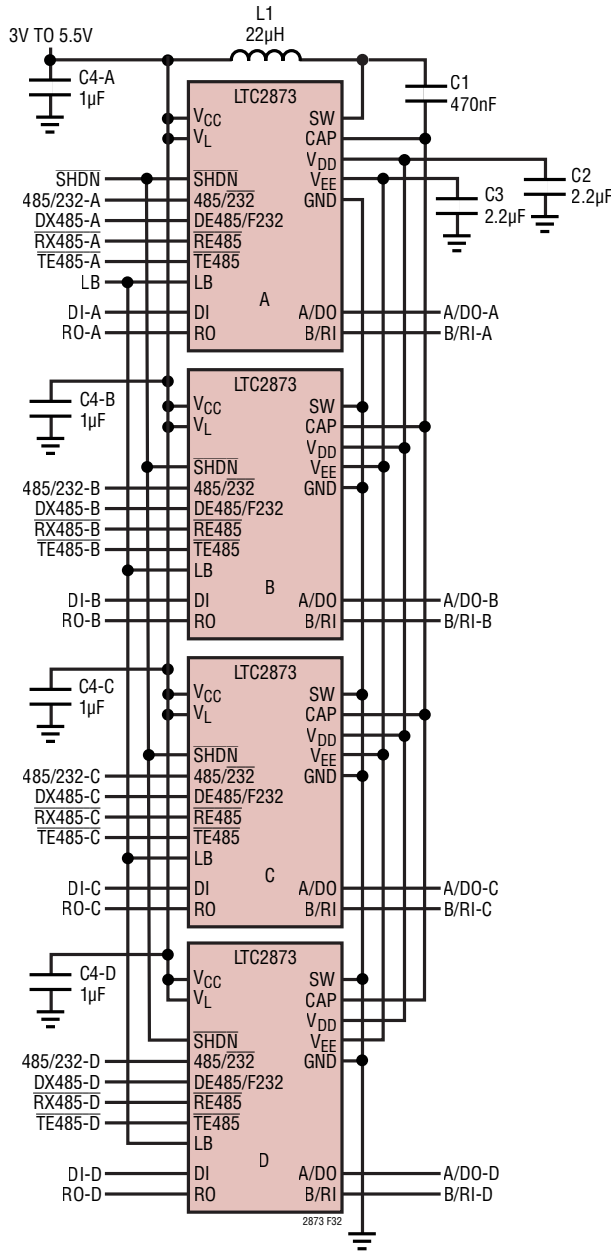
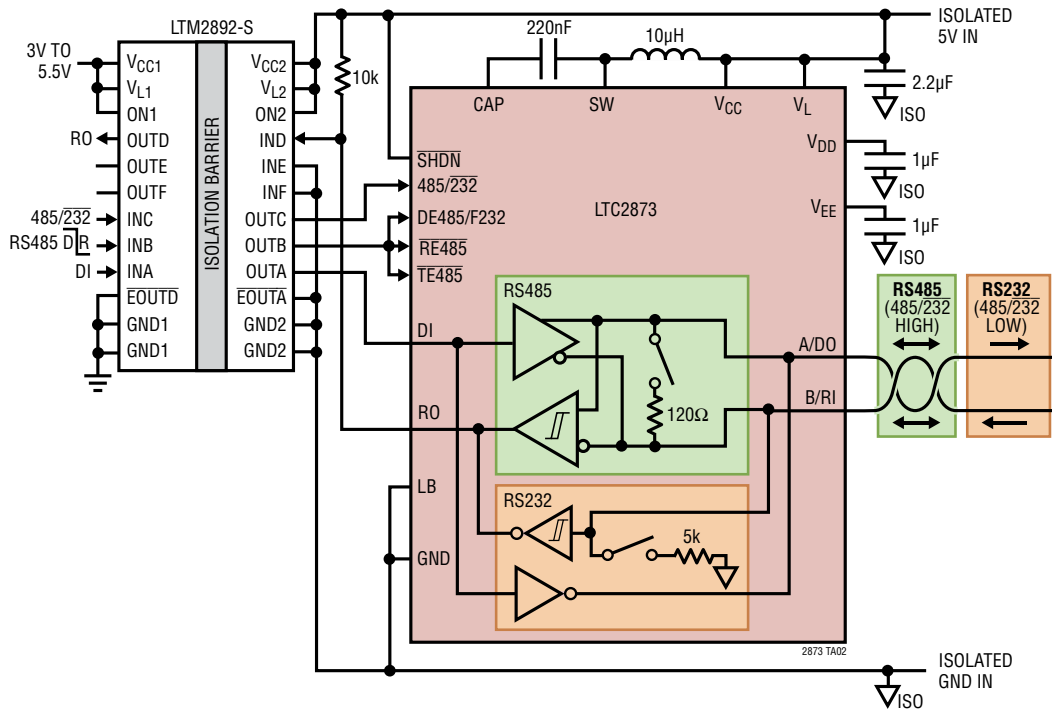

Figure 32. Quad Transceiver

TYPICAL APPLICATIONS

3500V_{RMS} Isolated RS485/RS232 Transceiver



PACKAGE DESCRIPTION

Please refer to <http://www.linear.com/product/LTC2873#packaging/> for the most recent package drawings.

UFD Package
24-Lead Plastic QFN (4mm × 5mm)
 (Reference LTC DWG # 05-08-1696 Rev A)

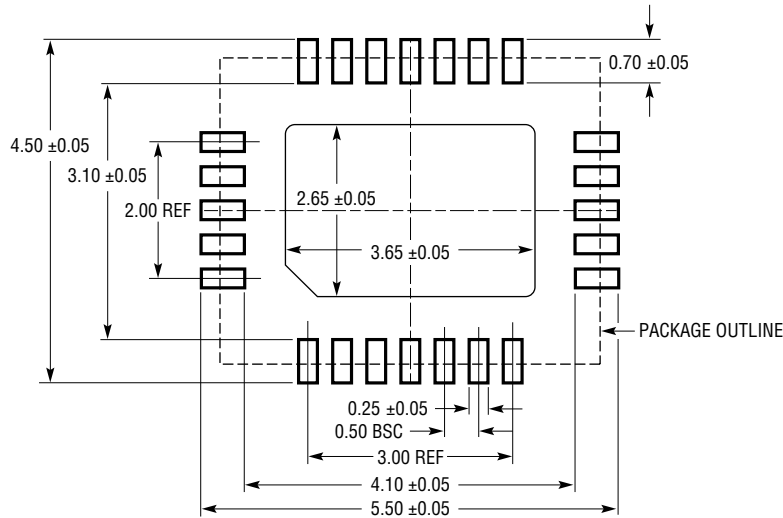

RECOMMENDED SOLDER PAD PITCH AND DIMENSIONS
 APPLY SOLDER MASK TO AREAS THAT ARE NOT SOLDERED

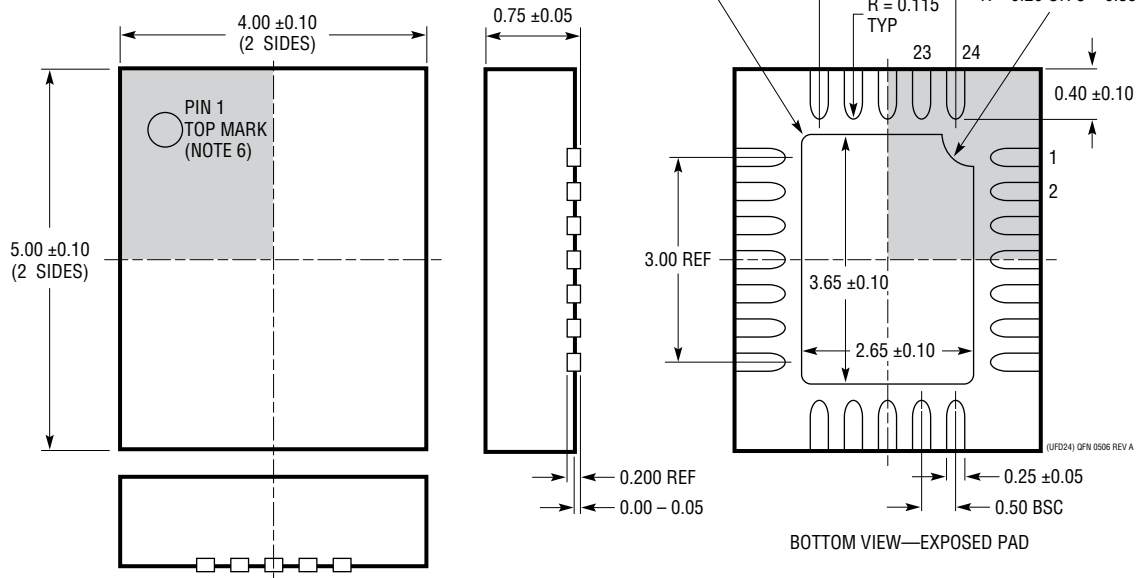

- NOTE:
1. DRAWING PROPOSED TO BE MADE A JEDEC PACKAGE OUTLINE MO-220 VARIATION (WXXX-X).
 2. DRAWING NOT TO SCALE
 3. ALL DIMENSIONS ARE IN MILLIMETERS
 4. DIMENSIONS OF EXPOSED PAD ON BOTTOM OF PACKAGE DO NOT INCLUDE MOLD FLASH. MOLD FLASH, IF PRESENT, SHALL NOT EXCEED 0.15mm ON ANY SIDE
 5. EXPOSED PAD SHALL BE SOLDER PLATED
 6. SHADED AREA IS ONLY A REFERENCE FOR PIN 1 LOCATION ON THE TOP AND BOTTOM OF PACKAGE

REVISION HISTORY

| REV | DATE | DESCRIPTION | PAGE NUMBER |
|-----|-------|---------------------------------------------------------------------------|-------------|
| A | 05/16 | Applied Note 7 to $t_{ZLSR232}$, $t_{ZHSR232}$. | 6 |
| | | Added Exposed Pad soldering requirement to V_{EE} pin description. | 9 |
| | | Corrected recommended Würth inductor part number. | 17 |
| B | 04/18 | Updated plot RS485 Driver Short-Circuit Current vs Short-Circuit Voltage. | 7 |
| | | Changed the approximate failsafe timeout from 1.3 μ s to 0.7 μ s. | 20 |
| | | Corrected a pin state in Figure 25 for the RS485 RX configuration. | 24 |
| | | Added a new Typical Application circuit. | 32 |
| | | Added LTM2885 to the Related Parts Table. | 32 |

TYPICAL APPLICATION

2500V_{RMS} Isolated RS485/RS232 Transceiver with Isolated Power

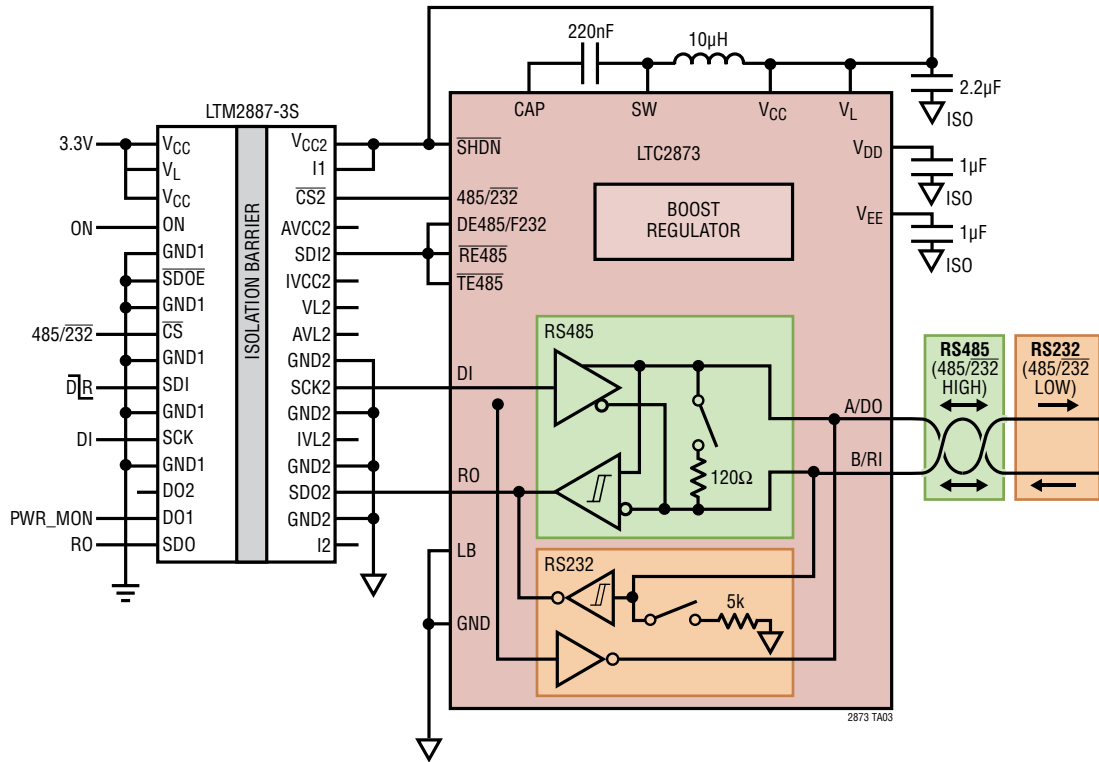

RELATED PARTS

| PART NUMBER | DESCRIPTION | COMMENTS |
|---------------------------------------------------|------------------------------------------------------------------------|----------------------------------------------------------------------------------------------------------------------------------------------------------|
| LTC2870 , LTC2871 | RS232/RS485 Multiprotocol Transceiver with Integrated Termination | Two RS232 and One RS485 Transceivers. 3V to 5.5V Supply, Automatic Selection of Termination Resistors, Duplex Control, Logic Supply Pin, Up to ±26kV ESD |
| LTC2872 | RS232/RS485 Dual Multiprotocol Transceiver with Integrated Termination | Four RS232 and Two RS485 Transceivers. 3V to 5.5V Supply, Automatic Selection of Termination Resistors, Duplex Control, Logic Supply Pin, ±15kV ESD |
| LTC1334 | Single 5V RS232/RS485 Multiprotocol Transceiver | Dual Port, Single 5V Supply, Configurable, ±10kV ESD |
| LTC1387 | Single 5V RS232/RS485 Multiprotocol Transceiver | Single Port, Configurable |
| LTC2801/LTC2802/LTC2803/LTC2804 | 1.8V to 5.5V RS232 Single and Dual Transceivers | Up to 1Mbps, ±10kV ESD, Logic Supply Pin, Tiny DFN Packages |
| LTC2854/LTC2855 | 3.3V 20Mbps RS485 Transceiver with Integrated Switchable Termination | 3.3V Supply, Integrated, Switchable, 120Ω Termination Resistor, ±25kV ESD |
| LTC2859/LTC2861 | 20Mbps RS485 Transceiver with Integrated Switchable Termination | 5V Supply, Integrated, Switchable, 120Ω Termination Resistor, ±15kV ESD |
| LTM[®]2881 | Complete Isolated RS485/RS422 µModule [®] Transceiver + Power | 20Mbps, 2500V _{RMS} Isolation with Integrated DC/DC Converter, Integrated Switchable 120Ω Termination Resistor, ±15kV ESD |
| LTM2885 | 6500V _{RMS} Isolated RS485/RS232 µModule Transceiver + Power | 20Mbps, 6500V _{RMS} Isolation with Integrated DC/DC Converter, Integrated Switchable 120ohm Termination Resistor, ±15kV ESD, 5V Supply |
| LTM2882 | Dual Isolated RS232 µModule Transceiver + Power | 1Mbps, 2500V _{RMS} Isolation with Integrated DC/DC Converter, ±10kV ESD |

Looking for pricing, stock, or lifecycle information?

Click below to explore more details on WIN SOURCE:

 [View LTC2873CUFD#TRPBF on WIN SOURCE](#)

 [Analog Devices Inc. Information](#)

Optimize Your Supply Chain with WIN SOURCE Solutions

-  Global Sourcing Solution
-  Obsolete Management
-  Cost Control Management
-  Shortage Management
-  Alternative Solution
-  Excess Inventory Management