



**THE DATASHEET OF  
NCF3320EHN/0Y**





## Contactless Automotive Reader IC NCx3320

# Automotive NFC Frontend IC Optimized for Secure Car Access

As a member of NXP®'s high-performance reader IC family, NCx3320 combines high RF output power with robust multiple protocol support. High integration and a small footprint make it ideal for small form-factor car door handles.

### KEY FEATURES

- ▶ Fully ISO/IEC 14443 A & B, ISO/IEC 15693 and FeliCa compliant
- ▶ ISO/NFC 18092 NFC-IP1 peer-to-peer support (initiator mode)
- ▶ RF driver supply voltage 3 V - 5.5 V with max current of 350 mA
- ▶ Compact HVQFN32 package (5 x 5 mm) with wettable flanks
- ▶ Low Power Card Detection
- ▶ 512 Byte FIFO
- ▶ High baud rates (up to 848 kbits)
- ▶ 8 KB EEPROM

### KEY BENEFITS

- ▶ High-output power RF front-end IC in small footprint
- ▶ Maximum reading distance combined with high operating stability
- ▶ Supports all relevant contactless protocols
- ▶ Full compatibility with NXP smart card, smart tags and label ICs
- ▶ Capable of handling long APDUs

- ▶ Fast card detection with minimum power consumption
- ▶ Stores application specific configuration
- ▶ Communication with mobile NFC devices in reader/writer or peer-to-peer initiator mode
- ▶ Supplied with generic software library easily portable across different MCUs

### KEY APPLICATIONS

- ▶ Secure car access
- ▶ Fleet management
- ▶ Car sharing
- ▶ Center stack reader for personalization

The NCx3320 combines uniquely high RF output power with a very small HVQFN package to ensure large and reliable reading distances with NFC-enabled smart phones and smart cards.



Its unique combination of features, paired with robustness and quality, creates a benchmark for the automotive industry, where applications require long lifetimes paired with energy efficiency. The NCx3320 makes it possible to create secure solutions with NXP's MIFARE® products. Implementation of the initiator mode of P2P communication enables full support of NFC-based use cases in an automotive environment. To support mobile phones and the emerging use of credentials in different form factors and protocols, the device also integrates a large internal EEPROM for fast and flexible configuration of register settings.

## DOOR HANDLE REFERENCE DESIGN

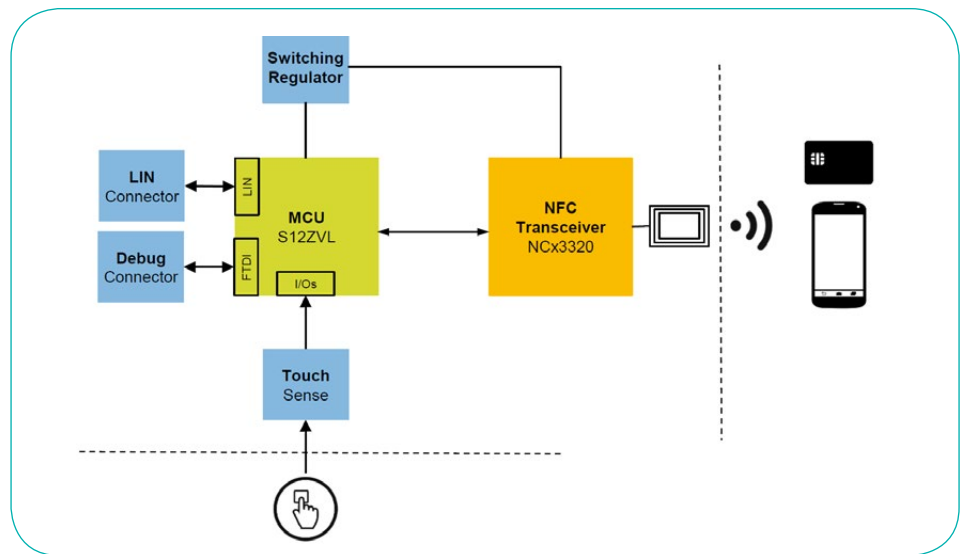

Automotive door handle reference design combining NXP's NCx3320 Reader IC with S12ZVL MCU

## NCx3320 FEATURES

PRODUCT FEATURES	NCx3320
Operating distance up to [mm]	100*
FIFO [bytes]	512
Host interfaces	SPI, I <sup>2</sup> C, RS232
<b>RF Interface</b>	
Analog interface	Fully integrated
Carrier frequency [MHz]	13.56
Modulation	10% & 100% ASK
Baudrate ISO 14443 [kbit/s]	106 / 212 / 424 / 848
Baudrate ISO 15693 [kbit/s]	6.78 / 26.5 / 53
Baudrate FeliCa [kbit/s]	212 / 424
<b>Standards and Protocols</b>	
NFC tag type reader	yes
ISO/IEC 14443 A,B	yes
ISO/IEC 15693	yes
MIFARE Classic® support	yes
ICODE EPC/UID protocol	yes
ISO/IEC 18000-3 Mode 3	yes
ISO/IEC 18092 (NFC)	yes, passive initiator mode
<b>Security Features</b>	
MIFARE Crypto 1	yes
<b>Additional Product Information</b>	
Supply voltage [V]	3 to 5.5
Power down current, typ. [nA] at 25°	40
Standby current, typ. [µA] at 25°	3
Temperature range [°C]	-40 to +85 (NCF), -40 to 105 (NCJ) and -40 to +125 (NCK)
Package HVQFN33	HVQFN32 with wettable flanks

\* Depends on antenna size and analog matching system

[www.nxp.com](http://www.nxp.com)

NXP, the NXP logo, MIFARE and MIFARE CLASSIC are trademarks of NXP B.V.  
All other product or service names are the property of their respective owners. © 2017 NXP B.V.

Document Number: AUTONCF3320LF REV 2  
Release Date: February 2017

## Looking for pricing, stock, or lifecycle information?

Click below to explore more details on WIN SOURCE:

 [View NCF3320EHN/0Y on WIN SOURCE](#)

 [NXP / Nexperia Information](#)

## Optimize Your Supply Chain with WIN SOURCE Solutions

-  Global Sourcing Solution
-  Obsolete Management
-  Cost Control Management
-  Shortage Management
-  Alternative Solution
-  Excess Inventory Management