



**THE DATASHEET OF
ZL50050GAG2**



DRV8306 38-V Brushless DC Motor Controller

1 Features

- 6-V to 38-V, Triple Half-Bridge Gate Driver With Integrated 3x Hall Comparators
 - 40-V Absolute Maximum Rating
 - Fully Optimized for 12-V and 24-V DC Rails
 - Drives High-Side and Low-Side N-Channel MOSFETs
 - Supports 100% PWM Duty Cycle
- Smart Gate Drive Architecture
 - Adjustable Slew-Rate Control for Better EMI and EMC Performance
 - V_{GS} Hand-Shake and Minimum Dead-Time Insertion to Avoid Shoot-Through
 - 15-mA to 150-mA Peak Source Current
 - 30-mA to 300-mA Peak Sink Current
- Integrated Commutation from Hall Sensors
 - 120° Trapezoidal Current Control
 - Supports Low-Cost Hall Elements
 - Tacho Output Signal (FGOUT) for Closed Loop Speed Control
- Integrated Gate Driver Power Supplies
 - High-Side Charge Pump
 - Low-Side Linear Regulator
- Cycle-by-Cycle Current Limit
- Supports 1.8-V, 3.3-V, and 5-V Logic Inputs
- Low-Power Sleep Mode
- Linear Voltage Regulator, 3.3 V, 30 mA
- Compact VQFN Package and Footprint
- Integrated Protection Features
 - VM Undervoltage Lockout (UVLO)
 - Charge Pump Undervoltage (CPUV)
 - MOSFET Overcurrent Protection (OCP)
 - Gate Driver Fault (GDF)
 - Thermal Shutdown (OTSD)
 - Fault Condition Indicator (nFAULT)

2 Applications

- BLDC Motor Modules
- Service Robots and Service Robotics
- Vacuum Cleaners
- Drones, Robotics, and RC Toys
- White Goods
- ATM and Currency Counting

3 Description

The DRV8306 device is an integrated gate driver for 3-phase brushless DC (BLDC) motor applications. The device provides three half-bridge gate drivers, each capable of driving high-side and low-side N-channel power MOSFETs. The DRV8306 device generates the proper gate drive voltages using an integrated charge pump for the high-side MOSFETs and a linear regulator for the low-side MOSFETs. The smart gate drive architecture supports up to 150-mA source and 300-mA sink peak gate drive current and 15-mA rms gate drive current capability.

The device provides an internal 120° commutation for the trapezoidal BLDC motor. The DRV8306 device has three Hall comparators which use the input from the Hall elements for internal commutation. The duty cycle ratio of the phase voltage of the motor can be adjusted through the PWM pin. Additional brake (nBRAKE) and direction (DIR) pins are provided for braking and setting the direction of the BLDC motor. A 3.3-V, 30-mA low-dropout (LDO) regulator is provided to supply the external controller and Hall elements. An additional FGOUT signal is provided which is a measure of the commutation frequency. This signal can be used for implementing the closed-loop control of BLDC motor.

A low-power sleep mode is provided to achieve low quiescent current draw by shutting down most of the internal circuitry. Internal protection functions are provided for undervoltage lockout, charge pump fault, MOSFET overcurrent, MOSFET short circuit, gate driver fault, and overtemperature. Fault conditions are indicated on the nFAULT pin.

Device Information⁽¹⁾

PART NUMBER	PACKAGE	BODY SIZE (NOM)
DRV8306	VQFN (32)	4.00 mm x 4.00 mm

(1) For all available packages, see the orderable addendum at the end of the data sheet.

Simplified Schematic

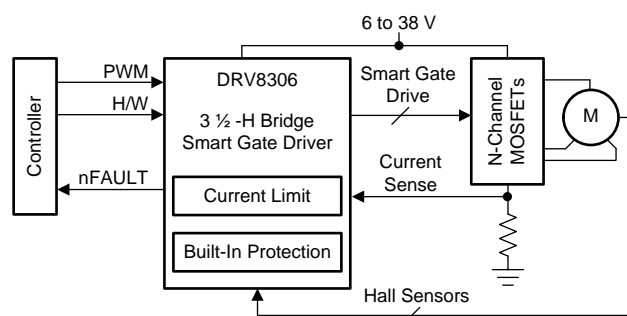

Table of Contents

1 Features	1	8 Application and Implementation	26
2 Applications	1	8.1 Application Information.....	26
3 Description	1	8.2 Typical Application	29
4 Revision History	2	9 Power Supply Recommendations	34
5 Pin Configuration and Functions	3	9.1 Bulk Capacitance Sizing	34
6 Specifications	4	10 Layout	35
6.1 Absolute Maximum Ratings	4	10.1 Layout Guidelines	35
6.2 ESD Ratings.....	4	10.2 Layout Example	36
6.3 Recommended Operating Conditions.....	5	11 Device and Documentation Support	37
6.4 Thermal Information	5	11.1 Device Support.....	37
6.5 Electrical Characteristics.....	5	11.2 Documentation Support	37
6.6 Typical Characteristics.....	8	11.3 Receiving Notification of Documentation Updates	37
7 Detailed Description	10	11.4 Community Resources.....	37
7.1 Overview	10	11.5 Trademarks	37
7.2 Functional Block Diagram	11	11.6 Electrostatic Discharge Caution.....	38
7.3 Feature Description.....	12	11.7 Glossary	38
7.4 Device Functional Modes.....	25	12 Mechanical, Packaging, and Orderable Information	38

4 Revision History

NOTE: Page numbers for previous revisions may differ from page numbers in the current version.

Changes from Original (April 2018) to Revision A

Page

- | | |
|--|----------|
| • Changed the status of the data sheet from <i>Advance Information</i> to <i>Production Data</i> | 1 |
|--|----------|

5 Pin Configuration and Functions

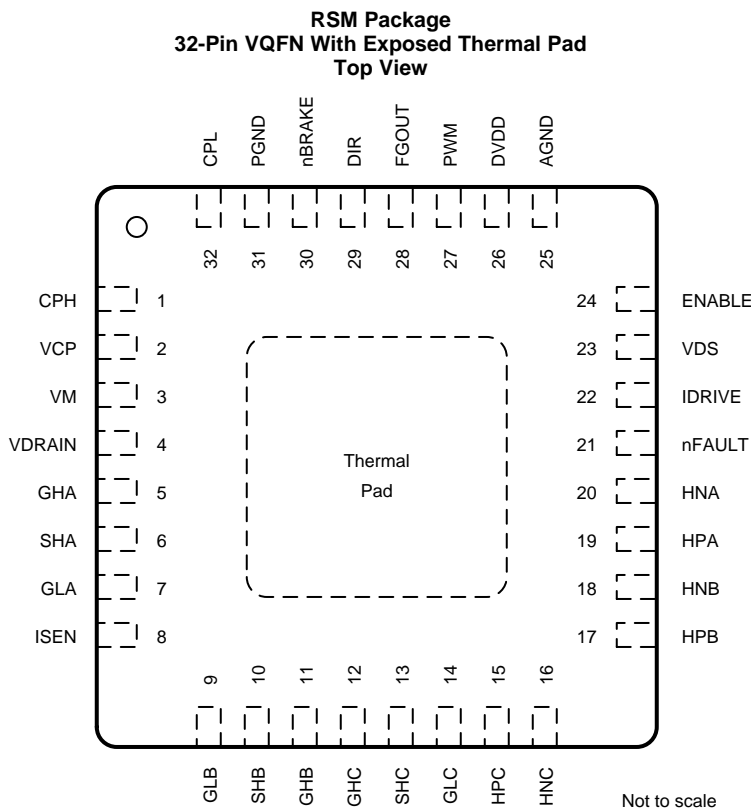

Pin Functions

PIN		TYPE ⁽¹⁾	DESCRIPTION
NAME	NO.		
AGND	25	PWR	Device analog ground. Connect to system ground.
CPH	1	PWR	Charge-pump switching node. Connect a X5R or X7R, 22-nF, VM-rated ceramic capacitor between the CPH and CPL pins.
CPL	32	PWR	Charge-pump switching node. Connect a X5R or X7R, 22-nF, VM-rated ceramic capacitor between the CPH and CPL pins.
DIR	29	I	Direction pin for setting the direction of the motor rotation to clockwise or counterclockwise. Internal pull-down resistor.
DVDD	26	PWR	3.3-V internal regulator output. Connect a X5R or X7R, 1-μF, 6.3-V ceramic capacitor between the DVDD and AGND pins. This regulator can source up to 30 mA externally.
ENABLE	24	I	Gate driver enable. When this pin is logic low the device enters a low-power sleep mode. A 15 to 40-μs low pulse can be used to reset fault conditions.
FGOUT	28	OD	Outputs a commutation zero crossing signal generated from Hall sensors.
GHA	5	O	High-side gate driver output. Connect to the gate of the high-side power MOSFET.
GHB	11	O	High-side gate driver output. Connect to the gate of the high-side power MOSFET.
GHC	12	O	High-side gate driver output. Connect to the gate of the high-side power MOSFET.
GLA	7	O	Low-side gate driver output. Connect to the gate of the low-side power MOSFET.
GLB	9	O	Low-side gate driver output. Connect to the gate of the low-side power MOSFET.
GLC	14	O	Low-side gate driver output. Connect to the gate of the low-side power MOSFET.
HNA	20	I	Hall element negative input. Noise filter capacitors may be desirable, connected between the positive and negative Hall inputs.
HNB	18	I	Hall element negative input. Noise filter capacitors may be desirable, connected between the positive and negative Hall inputs.
HNC	16	I	Hall element negative input. Noise filter capacitors may be desirable, connected between the positive and negative Hall inputs.
HPA	19	I	Hall element positive input. Noise filter capacitors may be desirable, connected between the positive and negative Hall inputs.
HPB	17	I	Hall element positive input. Noise filter capacitors may be desirable, connected between the positive and negative Hall inputs.
HPC	15	I	Hall element positive input. Noise filter capacitors may be desirable, connected between the positive and negative Hall inputs.
IDRIVE	22	I	Gate drive output current setting. This pin is a 7 level input pin set by an external resistor.
ISEN	8	I	Current sense for pulse-by-pulse current limit. Connect to low-side current sense resistor.
PGND	31	PWR	Device power ground. Connect to system ground.

(1) PWR = power, I = input, O = output, OD = open-drain

Pin Functions (continued)

PIN		TYPE ⁽¹⁾	DESCRIPTION
NAME	NO.		
PWM	27	I	PWM input for motor control. Set the output voltage and switching frequency of the phase voltage of the motor.
SHA	6	I	High-side source sense input. Connect to the high-side power MOSFET source.
SHB	10	I	High-side source sense input. Connect to the high-side power MOSFET source.
SHC	13	I	High-side source sense input. Connect to the high-side power MOSFET source.
VCP	2	PWR	Charge pump output. Connect a X5R or X7R, 1- μ F, 16-V ceramic capacitor between the VCP and VM pins.
VDRAIN	4	I	High-side MOSFET drain sense input. Connect to the common point of the MOSFET drains.
VDS	23	I	VDS monitor trip point setting. This pin is a 7 level input pin set by an external resistor.
VM	3	PWR	Gate driver power supply input. Connect to the bridge power supply. Connect a X5R or X7R, 0.1- μ F, VM-rated ceramic and greater than or equal to 10-uF local capacitance between the VM and PGND pins.
nBRAKE	30	I	Causes motor to brake. Internal pulldown resistor.
nFAULT	21	OD	Fault indicator output. This pin is pulled logic low during a fault condition and requires an external pullup resistor.

6 Specifications

6.1 Absolute Maximum Ratings

over operating ambient temperature range (unless otherwise noted)⁽¹⁾

	MIN	MAX	UNIT
Power supply voltage (VM)	-0.3	40	V
Voltage differential between any ground pin (AGND, DGND, PGND)	-0.5	0.5	V
Internal logic regulator voltage (DVDD)	-0.3	3.8	V
MOSFET voltage sense (VDRAIN)	-0.3	40	V
Charge pump voltage (VCP, CPH)	-0.3	VM + 13.5	V
Charge pump negative switching pin voltage (CPL)	-0.3	VM	V
Digital pin voltage (PWM, DIR, nBRAKE, nFAULT, ENABLE, VDS, IDRIVE, FGOUT)	-0.3	5.75	V
Open drain output current range (nFAULT, FGOUT)	0	5	mA
Continuous high-side gate pin voltage (GHX)	-2	VCP + 0.5	V
Pulsed 200 ns high-side gate pin voltage (GHX)	-5	VCP + 0.5	V
High-side gate voltage with respect to SHX (GHX)	-0.3	13.5	V
Continuous phase node pin voltage (SHX)	-2	VM + 2	V
Pulsed 200 ns phase node pin voltage (SHX)	-5	VM + 2	V
Continuous low-side gate pin voltage (GLX)	-1	13.5	V
Pulsed 200 ns low-side gate pin voltage (GLX)	-5	13.5	V
Gate pin source current (GHX, GLX)	Internally limited		A
Gate pin sink current (GHX, GLX)	Internally limited		A
Hall sensor input terminal voltage (HPA, HPB, HPC, HNA, HNB, HNC)	0	DVDD	V
Junction temperature, T _J	-40	150	°C
Storage temperature, T _{stg}	-65	150	°C

- (1) Stresses beyond those listed under *Absolute Maximum Rating* may cause permanent damage to the device. These are stress ratings only, which do not imply functional operation of the device at these or any other conditions beyond those indicated under *Recommended Operating Condition*. Exposure to absolute-maximum-rated conditions for extended periods may affect device reliability.

6.2 ESD Ratings

		VALUE	UNIT
V _(ESD)	Electrostatic discharge	Human body model (HBM), per ANSI/ESDA/JEDEC JS-001 ⁽¹⁾	±2000
		Charged device model (CDM), per JEDEC specification JESD22-C101 ⁽²⁾	±500

- (1) JEDEC document JEP155 states that 500-V HBM allows safe manufacturing with a standard ESD control process. Pins listed as ±2000 V may actually have higher performance.
- (2) JEDEC document JEP157 states that 250-V CDM allows safe manufacturing with a standard ESD control process. Pins listed as ±500 V may actually have higher performance.

6.3 Recommended Operating Conditions

over operating ambient temperature range (unless otherwise noted)

		MIN	MAX	UNIT
V_{VM}	Power supply voltage range	6	38	V
V_I	Logic level input voltage range	0	5.5	V
f_{PWM}	Applied PWM signal (PWM)		200 ⁽¹⁾	kHz
I_{GATE_HS}	High-side average gate drive current (GHX)		15 ⁽¹⁾	mA
I_{GATE_LS}	Low-side average gate drive current (GLX)		15 ⁽¹⁾	mA
I_{DVDD}	DVDD external load current		30 ⁽¹⁾	mA
f_{HALL}	Hall sensor input frequency	0	30	kHz
V_{OD}	Open drain pull up voltage (nFAULT, FGOOUT)	0	5.5	V
I_{OD}	Open drain output current (nFAULT, FGOOUT)	0	5	mA
T_A	Operating ambient temperature	-40	125	°C

(1) Power dissipation and thermal limits must be observed

6.4 Thermal Information

THERMAL METRIC ⁽¹⁾		DRV8306	UNIT
		RSM (VQFN)	
		32 PINS	
$R_{\theta JA}$	Junction-to-ambient thermal resistance	32.6	°C/W
$R_{\theta JC(top)}$	Junction-to-case (top) thermal resistance	29.3	°C/W
$R_{\theta JB}$	Junction-to-board thermal resistance	11.9	°C/W
ψ_{JT}	Junction-to-top characterization parameter	0.4	°C/W
ψ_{JB}	Junction-to-board characterization parameter	11.9	°C/W
$R_{\theta JC(bot)}$	Junction-to-case (bottom) thermal resistance	2.8	°C/W

(1) For more information about traditional and new thermal metrics, see the [Semiconductor and IC Package Thermal Metrics](#) application report.

6.5 Electrical Characteristics

at $V_{VM} = 6$ to 38 V over operating ambient temperature range (unless otherwise noted)

PARAMETER	TEST CONDITIONS	MIN	TYP	MAX	UNIT		
POWER SUPPLIES (VM, DVDD)							
I_{VM}	VM operating supply current	$V_{VM} = 24$ V; ENABLE = 1; PWM = 0 V		5	8	mA	
I_{VMQ}	VM sleep mode supply current	ENABLE = 0; $V_{VM} = 24$ V, $T_A = 25^\circ\text{C}$		20	40	μA	
		ENABLE = 0, $V_{VM} = 24$ V, $T_A = 125^\circ\text{C}$			100		
t_{RST}	Reset pulse time	ENABLE = 0 V period to reset faults		15	40	μs	
t_{SLEEP}	Sleep time	ENABLE = 0 V to driver tri-stated			200	μs	
t_{WAKE}	Wake-up time	$V_{VM} > V_{UVLO}$; ENABLE = 3.3 V to output transition			1	ms	
V_{DVDD}	Internal logic regulator voltage	$I_{DVDD} = 0$ to 30 mA		2.9	3.3	3.6	V
CHARGE PUMP (VCP, CPH, CPL)							
V_{VCP}	VCP operating voltage with respect to VM	$V_M = 12$ to 38 V; $I_{VCP} = 0$ to 15 mA		7	10	11.5	V
		$V_M = 10$ V; $I_{VCP} = 0$ to 10 mA		6.5	7.5	9.5	
		$V_M = 8$ V; $I_{VCP} = 0$ to 5 mA		5	6	7.5	
		$V_M = 6$ V; $I_{VCP} = 0$ to 1 mA		3.8	4.3	6.5	
LOGIC-LEVEL INPUTS (PWM, DIR, nBRAKE)							
V_{IL}	Input logic low voltage			0	0.8	V	
V_{IH}	Input logic high voltage			1.5	5.5	V	
V_{HYS}	Input logic hysteresis			100		mV	
I_{IL}	Input logic low current	V_{PIN} (Pin Voltage) = 0 V		-1	1	μA	

Electrical Characteristics (continued)

 at $V_{VM} = 6$ to 38 V over operating ambient temperature range (unless otherwise noted)

PARAMETER		TEST CONDITIONS	MIN	TYP	MAX	UNIT
I_{IH}	Input logic high current	V_{PIN} (Pin Voltage) = 5 V			100	μ A
R_{PD}	Pulldown resistance (PWM, DIR, nBRAKE)	Internal pulldown to AGND		100		k Ω
LOGIC-LEVEL INPUTS (ENABLE)						
V_{IL}	Input logic low voltage		0		0.6	V
V_{IH}	Input logic high voltage		1.5		5.5	V
V_{HYS}	Input logic hysteresis		100			mV
I_{IL}	Input logic low current	V_{PIN} (Pin Voltage) = 0 V	-10		10	μ A
I_{IH}	Input logic high current	V_{PIN} (Pin Voltage) = 5 V	-5		5	μ A
SEVEN-LEVEL INPUTS (IDRIVE, VDS)						
V_{I1}	Input mode 1 voltage	Tied to AGND		0		V
V_{I2}	Input mode 2 voltage	18 k Ω \pm 5% to AGND		0.5		V
V_{I3}	Input mode 3 voltage	75 k Ω \pm 5% to AGND		1.1		V
V_{I4}	Input mode 4 voltage	Hi-Z		1.65		V
V_{I5}	Input mode 5 voltage	75 k Ω \pm 5% to DVDD		2.2		V
V_{I6}	Input mode 6 voltage	18 k Ω \pm 5% to DVDD		2.8		V
V_{I7}	Input mode 7 voltage	Tied to DVDD		3.3		V
OPEN-DRAIN OUTPUTS (nFAULT, FGOUT)						
V_{OL}	Output logic low voltage	$I_{OD} = 2$ mA			0.1	V
I_{OZ}	Output logic high current	$V_{OD} = 5$ V	-1		1	μ A
GATE DRIVERS (GHX, SHX, GLX)						
V_{GHS}	High-side V_{GS} gate drive (gate-to-source)	$V_{VM} = 12$ to 38 V; $I_{HS_GATE} = 0$ to 15 mA	7	10	11.5	V
		$V_{VM} = 10$ V; $I_{HS_GATE} = 0$ to 10 mA	6.5	7.5	8.5	
		$V_{VM} = 8$ V; $I_{HS_GATE} = 0$ to 5 mA	5	6	7	
		$V_{VM} = 6$ V; $I_{HS_GATE} = 0$ to 1 mA	3.8	4.3	6.5	
V_{GSL}	Low-side V_{GS} gate drive (gate-to-source)	$V_{VM} = 12$ to 38 V; $I_{LS_GATE} = 0$ to 15 mA	7.5	10	12.5	V
		$V_{VM} = 10$ V; $I_{LS_GATE} = 0$ to 10 mA	5.5	7.5	9.5	
		$V_{VM} = 8$ V; $I_{LS_GATE} = 0$ to 5 mA	3.5	6	8.5	
		$V_{VM} = 6$ V; $I_{LS_GATE} = 0$ to 1 mA	3	4.3	6.5	
t_{DEAD}	Output dead time			120		ns
t_{DRIVE}	Peak gate drive time			4000		ns
I_{DRIVEP}	Peak source gate current (high-side and low-side)	IDRIVE tied to AGND		15		mA
		IDRIVE 18 k Ω (\pm 5%) to AGND		45		
		IDRIVE 75 k Ω (\pm 5%) to AGND		60		
		IDRIVE Hi-Z (> 500 k Ω to AGND)		90		
		IDRIVE 75 k Ω (\pm 5%) to DVDD		105		
		IDRIVE 18 k Ω (\pm 5%) to DVDD		135		
		IDRIVE tied to DVDD		150		
I_{DRIVEN}	Peak sink gate current (high-side and low-side)	IDRIVE tied to AGND		30		mA
		IDRIVE 18 k Ω (\pm 5%) to AGND		90		
		IDRIVE 75 k Ω (\pm 5%) to AGND		120		
		IDRIVE Hi-Z (> 500 k Ω to AGND)		180		
		IDRIVE 75 k Ω (\pm 5%) to DVDD		210		
		IDRIVE 18 k Ω (\pm 5%) to DVDD		270		
		IDRIVE tied to DVDD		300		

Electrical Characteristics (continued)

 at $V_{VM} = 6$ to 38 V over operating ambient temperature range (unless otherwise noted)

PARAMETER		TEST CONDITIONS	MIN	TYP	MAX	UNIT
I_{HOLD}	FET holding current	Source current after t_{DRIVE}		15		mA
		Sink current after t_{DRIVE}		30		
I_{STRONG}	FET hold-off strong pulldown	GHX and GLX		300		mA
R_{OFF}	FET gate hold-off resistor	GHX to SHX and GLX to PGND		150		k Ω
t_{PD}	Propagation delay	PWM transition to GHX/GLX transition		180	250	ns
HALL SENSOR INPUTS (HPX, HNX)						
V_{HYS}	Hall comparator hysteresis voltage		20	30	40	mV
ΔV_{HYS}	Hall comparator hysteresis difference	Between A, B and C	-5		5	mV
V_{ID}	Hall comparator input differential		50			mV
V_{CM}	Hall comparator input common mode voltage CM range		1.5		3.5	V
I_l	Input leakage current	HPX = HNX = 0 V	-1		1	μ A
t_{HDEG}	Hall deglitch time			5		μ s
CYCLE-BY-CYCLE CURRENT LIMIT (ISEN)						
V_{LIMIT}	Voltage limit across R_{SENSE} for the current limiter		0.225	0.25	0.275	V
t_{BLANK}	Time that V_{LIMIT} is ignored from the start of the PWM cycle			5		μ s
PROTECTION CIRCUITS						
V_{UVLO}	VM undervoltage lockout	VM falling, UVLO report	5.4		5.8	V
		VM rising, UVLO recovery	5.6		6	
V_{UVLO_HYS}	VM undervoltage hysteresis	Rising to falling threshold		200		mV
t_{UVLO_DEG}	VM undervoltage deglitch time	VM falling, UVLO report		10		μ s
V_{CPUV}	Charge pump undervoltage	With respect to VM		2.4		V
V_{GS_CLAMP}	Gate drive clamping voltage	Positive clamping voltage	10.5		15	V
		Negative clamping voltage		-0.6		
V_{DS_OCP}	V_{DS} overcurrent trip voltage	VDS tied to AGND		0.15		V
		VDS 18 k Ω (\pm 5%) to AGND		0.24		
		VDS 75 k Ω (\pm 5%) to AGND		0.4		
		VDS Hi-Z (> 500 k Ω to AGND)		0.6		
		VDS 75 k Ω (\pm 5%) to DVDD		0.9		
		VDS 18 k Ω (\pm 5%) to DVDD		1.8		
V_{SEN_OCP}	V_{SENSE} overcurrent trip voltage		1.7	1.8	1.9	V
t_{OCP_DEG}	V_{DS} and V_{SENSE} overcurrent deglitch time			4.5		μ s
t_{RETRY}	Overcurrent retry time			4		ms
T_{OTSD}	Thermal shutdown temperature	Die temperature T_j	150	170		$^{\circ}$ C
T_{HYS}	Thermal hysteresis	Die temperature T_j		20		$^{\circ}$ C

6.6 Typical Characteristics

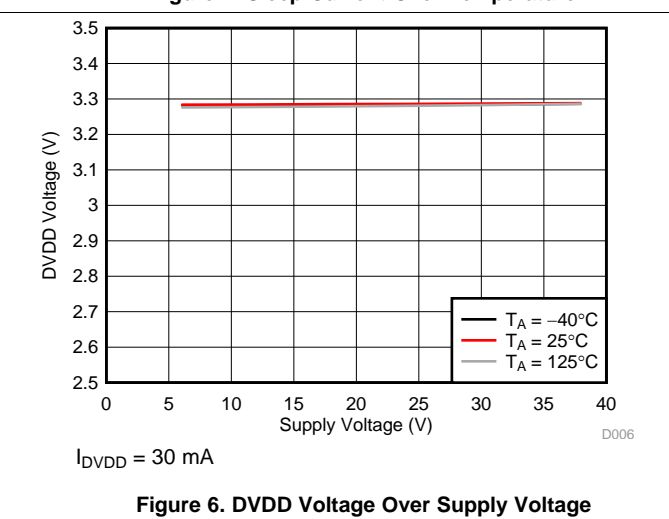
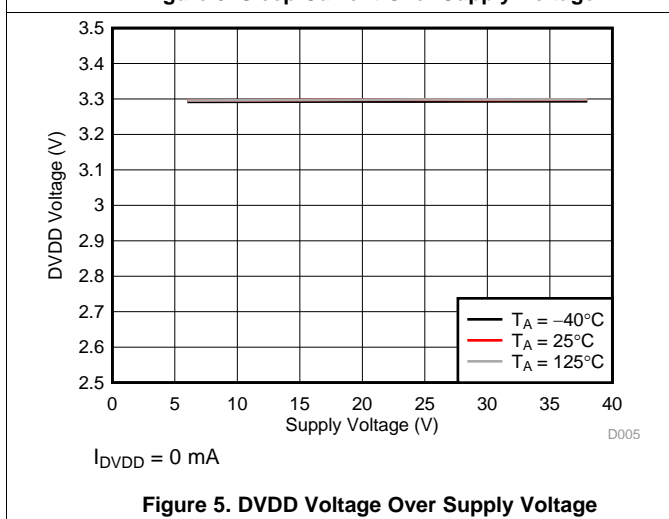
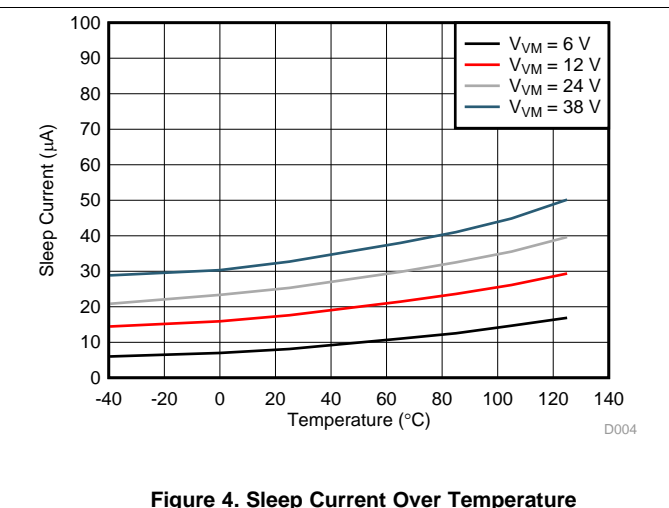
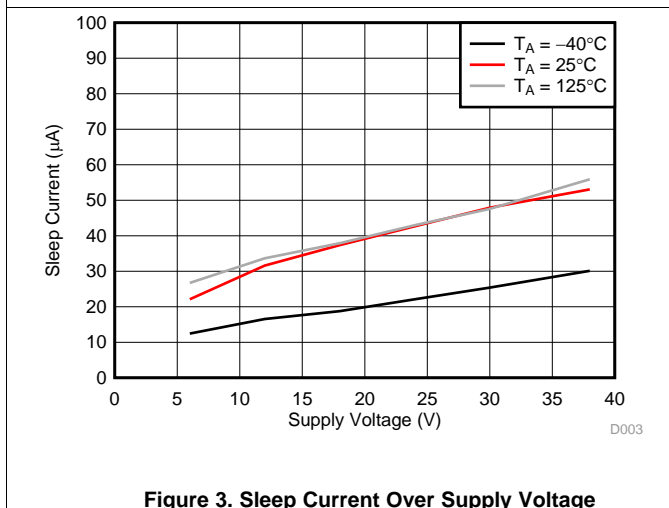
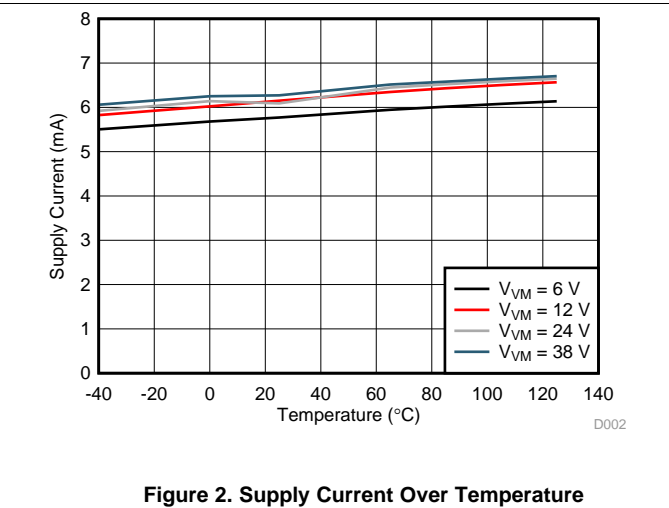
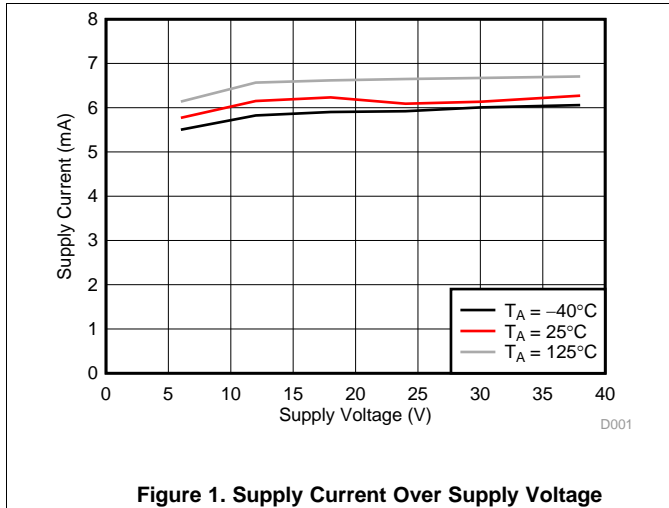

Typical Characteristics (continued)

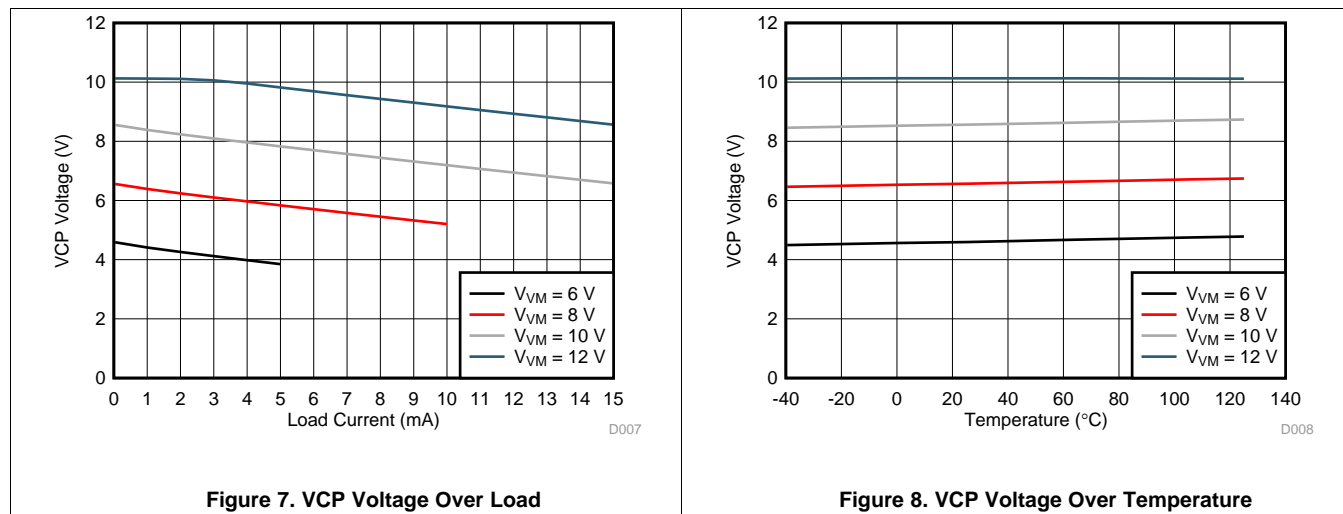

7 Detailed Description

7.1 Overview

The DRV8306 device is an integrated 6-V to 38-V gate driver for three-phase motor-drive applications. The device reduces system component count, cost, and complexity by integrating three independent half-bridge gate drivers, charge pump, and linear low-dropout (LDO) regulator for the high-side and low-side gate-driver supply voltages. A hardware interface (H/W) option allows for configuring the most commonly used settings through fixed external resistors.

The gate drivers support external N-channel high-side and low-side power MOSFETs and can drive up to 150-mA source and 300-mA sink peak currents with a 15-mA average output current. The high-side gate drive supply voltage is generated using a doubler charge-pump architecture that regulates the VCP output to $V_{VM} + 10$ V. The low-side gate drive supply voltage is generated using a linear regulator from the VM power supply that regulates to 10 V. A smart gate-drive architecture provides the ability to adjust the output gate-drive current strength allowing for the gate driver to control the power MOSFET V_{DS} switching speed. This allows for the removal of external gate drive resistors and diodes reducing BOM component count, cost, and PCB area. The architecture also uses an internal state machine to protect against gate-drive short-circuit events, control the half-bridge dead time, and protect against dV/dt parasitic turnon of the external power MOSFET.

The DRV8306 device also integrates three Hall comparators for rotor position sensing using the Hall elements. This input is used for electronically commutating the BLDC motor in trapezoidal mode. This device also has a 3.3-V LDO regulator which can be powered up to loads up to 30 mA.

In addition to the high level of device integration, the DRV8306 device provides a wide range of integrated protection features. These features include power-supply undervoltage lockout (UVLO), charge-pump undervoltage lockout (CPUV), V_{DS} and V_{SENSE} overcurrent monitoring (OCP), gate-driver short-circuit detection (GDF), and overtemperature shutdown (OTSD). Fault events are indicated by the nFAULT pin.

The DRV8306 device is available in a 0.4-mm pin pitch, VQFN surface-mount package. The VQFN package size is 4-mm × 4-mm.

7.2 Functional Block Diagram

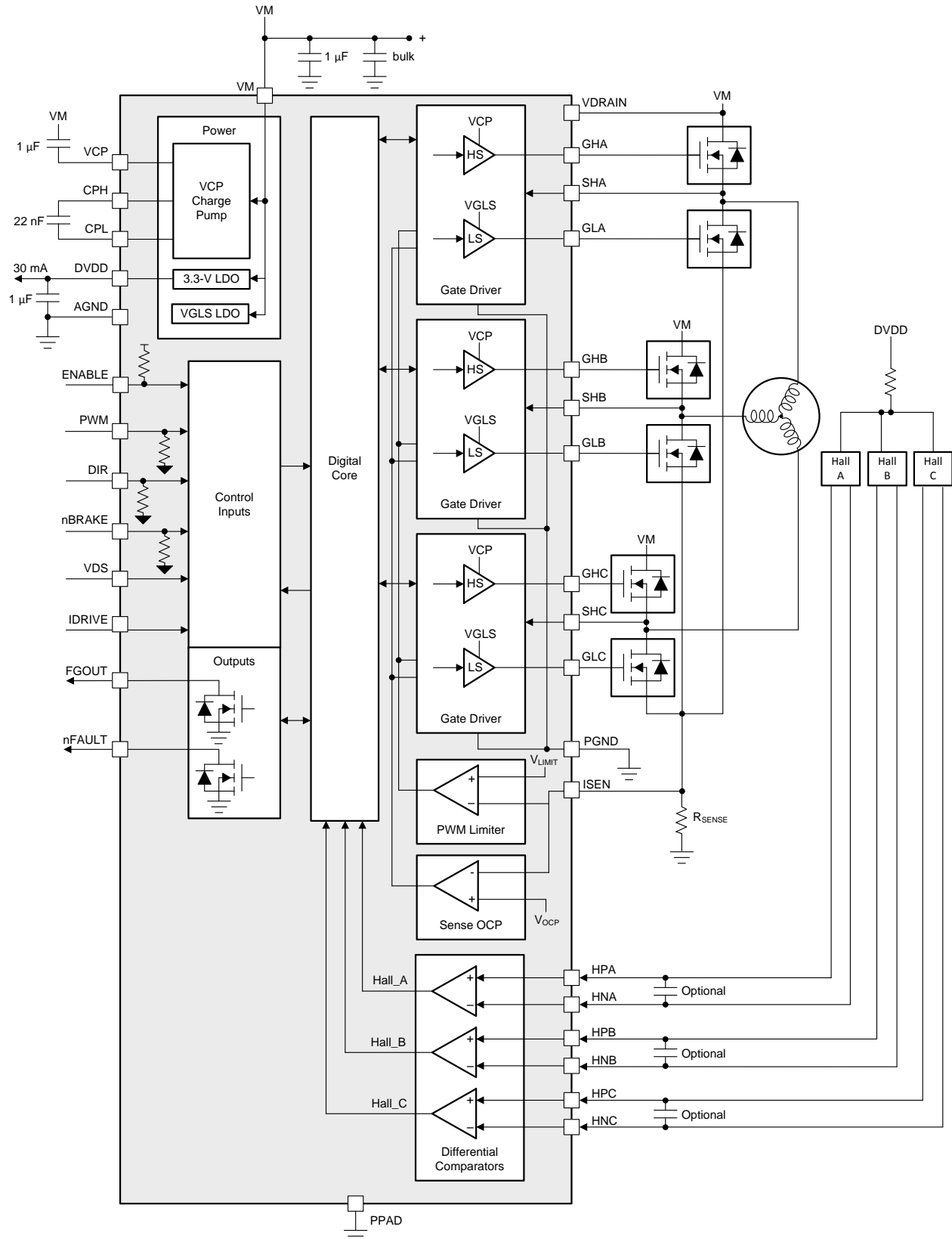

7.3 Feature Description

Table 1 lists the recommended values of the external components for the gate driver.

Table 1. DRV8306 Gate-Driver External Components

COMPONENTS	PIN 1	PIN 2	RECOMMENDED
C _{VM1}	VM	PGND	X5R or X7R, 0.1-μF, VM-rated capacitor
C _{VM2}	VM	PGND	≥ 10-μF, VM-rated capacitor
C _{VCP}	VCP	VM	X5R or X7R, 16-V, 1-μF capacitor
C _{SW}	CPH	CPL	X5R or X7R, VM-rated capacitor, 22-nF capacitor
C _{DVDD}	DVDD	AGND	X5R or X7R, 1-μF, 6.3-V capacitor
R _{nFAULT}	VCC ⁽¹⁾	nFAULT	Pullup resistor
R _{PWM}	PWM	AGND or DVDD	DRV8306 hardware interface
R _{BRK}	nBRAKE	AGND or DVDD	DRV8306 hardware interface
R _{DIR}	DIR	AGND or DVDD	DRV8306 hardware interface
R _{IDRIVE}	IDRIVE	AGND or DVDD	DRV8306 hardware interface
R _{VDS}	VDS	AGND or DVDD	DRV8306 hardware interface

(1) The VCC pin is not a pin on the DRV8306 device, but a VCC supply-voltage pullup is required for the open-drain output nFAULT and SDO. These pins can also be pulled up to DVDD.

7.3.1 Three Phase Smart Gate Drivers

The DRV8306 device integrates three, half-bridge gate drivers, each capable of driving high-side and low-side N-channel power MOSFETs. A doubler charge pump provides the proper gate bias voltage to the high-side MOSFET across a wide operating voltage range in addition to providing 100% duty-cycle support. An internal linear regulator provides the gate-bias voltage for the low-side MOSFETs.

The DRV8306 device implements a smart gate-drive architecture which lets the user dynamically adjust the gate drive current (through the IDRIVE pin) without requiring external gate current limiting resistors. Additionally, this architecture provides a variety of protection features for the external MOSFETs including automatic dead-time insertion, parasitic dV/dt gate turnon prevention, and gate-fault detection.

7.3.1.1 PWM Control Mode (1x PWM Mode)

The DRV8306 device provides a 1x PWM control mode for driving the BLDC motor into trapezoidal current-control mode. The DRV8306 device uses 6-step block commutation tables that are stored internally. This feature lets a three-phase BLDC motor be controlled using a single PWM sourced from a simple controller. The PWM is applied on the PWM pin and determines the output frequency and duty cycle of the half-bridges.

The half-bridge output states are managed by the HPA, HNA, HPB, HNB, HPC and HNC pins which are used as state logic inputs. The state inputs are the position feedback of the BLDC motor. The device always operates with synchronous rectification.

The DIR pin controls the direction of BLDC motor in either clockwise or counter-clockwise direction. Tie the DIR pin low if this feature is not required.

The nBRAKE input halts the motor by turning off all high-side MOSFETs and turning on all low-side MOSFETs when it is pulled low. This brake is independent of the states of the other input pins. Tie the nBRAKE pin high if this feature is not required.

Table 2. Synchronous 1x PWM Mode

STATE	HALL INPUTS						GATE-DRIVE OUTPUTS						DESCRIPTION
	DIR = 0			DIR = 1			PHASE A		PHASE B		PHASE C		
	HALL_A	HALL_B	HALL_C	HALL_A	HALL_B	HALL_C	GHA	GLA	GHB	GLB	GHC	GLC	
Stop	0	0	0	0	0	0	L	L	L	L	L	L	Stop
Align	1	1	1	1	1	1	PWM	!PWM	L	H	L	H	Align
1	1	1	0	0	0	1	L	L	PWM	!PWM	L	H	B → C
2	1	0	0	0	1	1	PWM	!PWM	L	L	L	H	A → C
3	1	0	1	0	1	0	PWM	!PWM	L	H	L	L	A → B
4	0	0	1	1	1	0	L	L	L	H	PWM	!PWM	C → B
5	0	1	1	1	0	0	L	H	L	L	PWM	!PWM	C → A
6	0	1	0	1	0	1	L	H	PWM	!PWM	L	L	B → A

Figure 9 shows the configuration in 1x PWM mode.

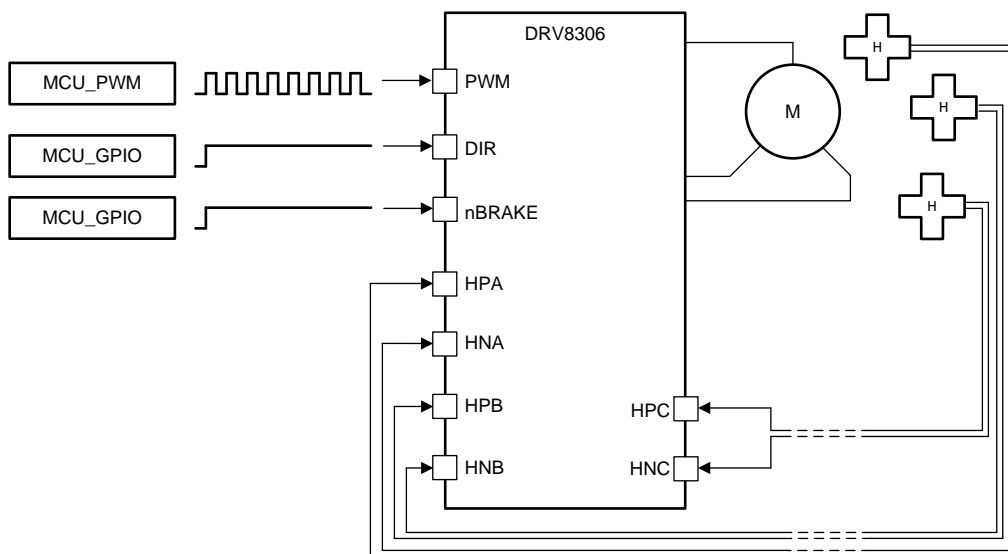

Figure 9. 1x PWM Mode

7.3.1.2 Hardware Interface Mode

The DRV8306 device supports a hardware interface mode for simple end-application design. In this hardware interface device, the V_{DS} overcurrent limit and the gate drive current levels can be configured through the resistor-configurable inputs, IDRIVE and VDS. This feature lets the application designer configure the most commonly used device settings by tying the pin logic high or logic low, or with a simple pullup or pulldown resistor.

The IDRIVE pin configures the gate drive current strength. The VDS pin configures the voltage threshold of the V_{DS} overcurrent monitors.

For more information on the hardware interface, see the [Pin Diagrams](#) section.

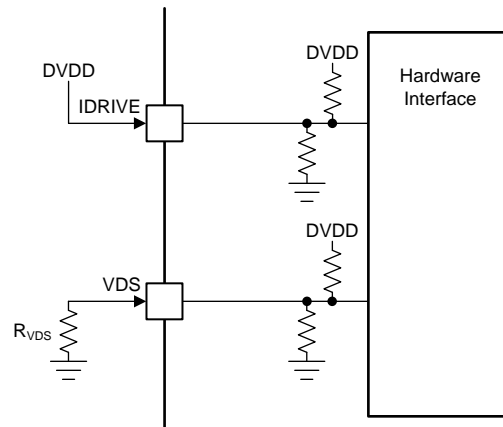

Figure 10. Sample Configuration of Hardware Interface

7.3.1.3 Gate Driver Voltage Supplies

The high-side gate-drive voltage supply is created using a doubler charge pump that operates from the VM voltage supply input. The charge pump lets the gate driver correctly bias the high-side MOSFET gate with respect to its source across a wide input supply voltage range. The charge pump is regulated to maintain a fixed output voltage of $V_{VM} + 10\text{ V}$ and supports an average output current of 15 mA. When the V_{VM} voltage is less than 12 V, the charge pump operates in full doubler mode and generates $V_{VCP} = 2 \times V_{VM} - 1.5\text{ V}$ when unloaded. The charge pump is continuously monitored for undervoltage to prevent under-driven MOSFET conditions. The charge pump requires a X5R or X7R, 1- μF , 16-V ceramic capacitor between the VM and VCP pins to act as the storage capacitor. Additionally, a X5R or X7R, 22-nF, VM-rated ceramic capacitor is required between the CPH and CPL pins to act as the flying capacitor.

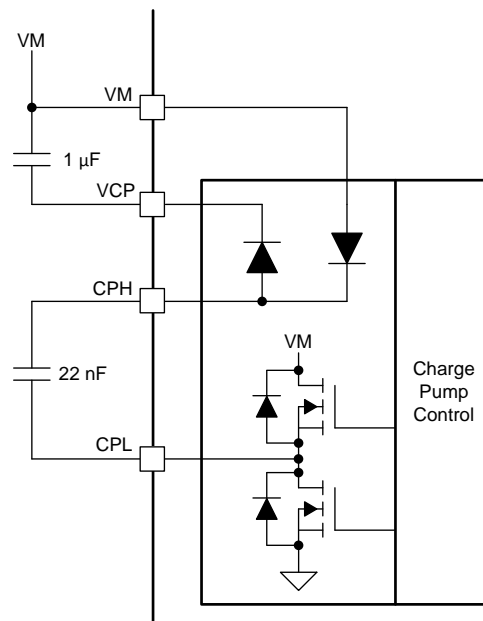

Figure 11. Charge Pump Architecture

The low-side gate drive voltage is created using a linear low-dropout (LDO) regulator that operates from the VM voltage supply input. The LDO regulator allows the gate driver to properly bias the low-side MOSFET gate with respect to ground. The LDO regulator output is fixed at 10 V and supports an output current of 15 mA. The LDO regulator is monitored for undervoltage to prevent under-driven MOSFET conditions.

7.3.1.4 Smart Gate Drive Architecture

The DRV8306 gate drivers use an adjustable, complimentary, push-pull topology for both the high-side and low-side drivers. This topology allows for both a strong pullup and pulldown of the external MOSFET gates.

Additionally, the gate drivers use a smart gate-drive architecture to provide additional control of the external power MOSFETs, take additional steps to protect the MOSFETs, and allow for optimal tradeoffs between efficiency and robustness. This architecture is implemented through two components called IDRIVE and TDRIVE which are detailed in the [IDRIVE: MOSFET Slew-Rate Control](#) section and [TDRIVE: MOSFET Gate Drive Control](#) section. [Figure 12](#) shows the high-level functional block diagram of the gate driver.

The IDRIVE gate-drive current and TDRIVE gate-drive time should be initially selected based on the parameters of the external power MOSFET used in the system and the desired rise and fall times (see the [Application and Implementation](#) section).

The high-side gate driver also implements a Zener clamp diode to help protect the external MOSFET gate from overvoltage conditions in the case of external short-circuit events on the MOSFET.

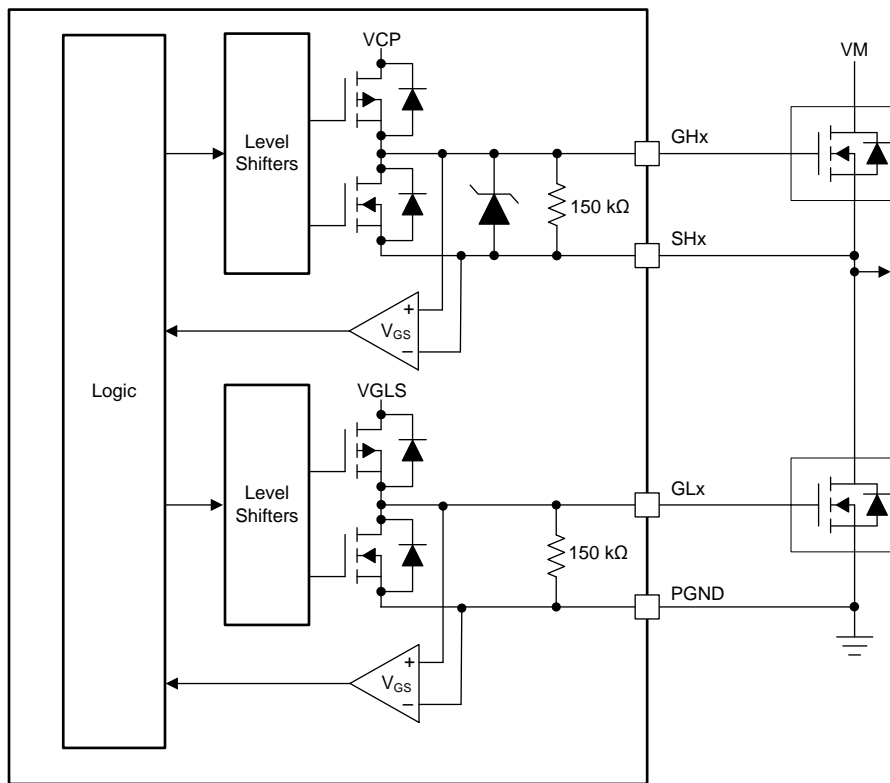

Figure 12. Gate Driver Block Diagram

7.3.1.4.1 IDRIVE: MOSFET Slew-Rate Control

The IDRIVE component implements adjustable gate-drive current to control the MOSFET V_{DS} slew rates. The MOSFET V_{DS} slew rates are a critical factor for optimizing radiated emissions, energy and duration of diode recovery spikes, dV/dt gate turnon leading to shoot-through, and switching voltage transients related to parasitics in the external half-bridge. The IDRIVE component operates on the principal that the MOSFET V_{DS} slew rates are predominately determined by the rate of gate charge (or gate current) delivered during the MOSFET Q_{GD} or Miller charging region. By allowing the gate driver to adjust the gate current, it can effectively control the slew rate of the external power MOSFETs.

The IDRIVE component allows the DRV8306 device to dynamically switch between gate drive currents through an IDRIVE pin. This hardware interface device provides seven I_{DRIVE} settings from 15-mA to 150-mA (source) and 30-mA to 300-mA (sink). The gate drive current setting is delivered to the gate during the turnon and turnoff of the external power MOSFET for the t_{DRIVE} duration. After the MOSFET turnon or turnoff, the gate driver switches to a smaller hold current (I_{HOLD}) to improve the gate driver efficiency. Additional details on the IDRIVE settings are described in the [Pin Diagrams](#) section.

7.3.1.4.2 TDRIVE: MOSFET Gate Drive Control

The TDRIVE component is an integrated gate-drive state machine that provides automatic dead time insertion through switching handshaking, parasitic dV/dt gate turnon prevention, and MOSFET gate-fault detection.

The first component of the TDRIVE state machine is automatic dead-time insertion. Dead time is period of time between the switching of the external high-side and low-side MOSFETs to ensure that they do not cross conduct and cause shoot-through. The DRV8306 device uses V_{GS} voltage monitors to measure the MOSFET gate-to-source voltage and determine the proper time to switch instead of relying on a fixed time value. This feature allows the gate-driver dead time to adjust for variation in the system such as temperature drift and variation in the MOSFET parameters. An additional digital dead time (t_{DEAD}) is inserted on top of the gate-driver dead time and is fixed for the DRV8306 device.

The second component focuses on prevention of parasitic dV/dt gate turnon. To implement this feature, the TDRIVE state machine enables a strong pulldown current (I_{STRONG}) on the opposite MOSFET gate whenever a MOSFET is switching. The strong pulldown last for the TDRIVE duration. This feature helps remove parasitic charge that couples into the MOSFET gate when the half-bridge switch-node voltage slews rapidly.

The third component implements a gate-fault detection scheme to detect pin-to-pin solder defects, a MOSFET gate failure, or a MOSFET gate stuck-high or stuck-low voltage condition. This implementation is done with a pair of V_{GS} gate-to-source voltage monitors for each half-bridge gate driver. When the gate driver receives a command to change the state of the half-bridge it begins to monitor the gate voltage of the external MOSFET. If the V_{GS} voltage has not reached the proper threshold at the end of the t_{DRIVE} period, the gate driver reports a fault. To ensure that a false fault is not detected, the user must ensure that the t_{DRIVE} time is longer than the time required to charge or discharge the MOSFET gate (this setting can be configured indirectly using the IDRIVE pin). The t_{DRIVE} time does not increase the PWM time and will terminate if another PWM command is received while active. Additional details on the TDRIVE settings are described in the [Pin Diagrams](#) section for hardware interface devices.

Figure 13 shows an example of the TDRIVE state machine in operation.

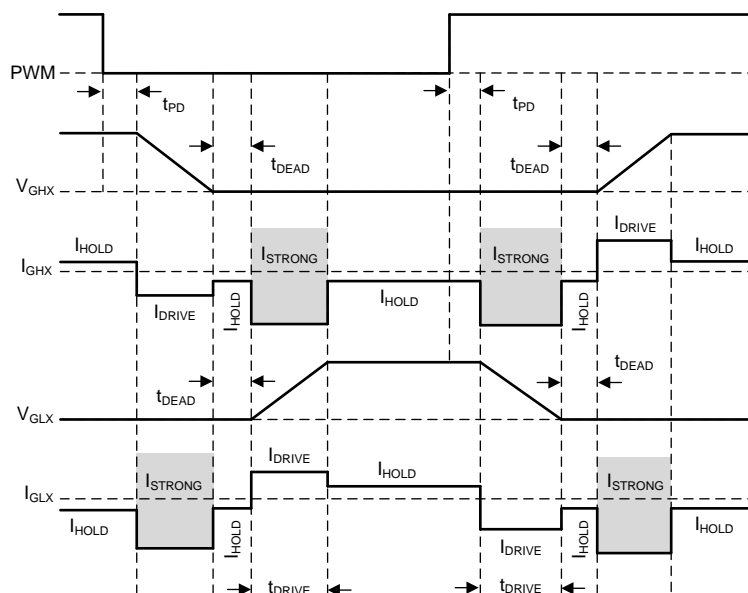

Figure 13. TDRIVE State Machine

7.3.1.4.3 Gate Drive Clamp

A clamping structure limits the gate drive output voltage to the V_{GS_CLAMP} voltage to help protect the external high-side MOSFETs from gate overvoltage damage. The positive voltage clamp is realized using a series of diodes. The negative voltage clamp uses the body diodes of the internal pulldown gate driver as shown in Figure 14.

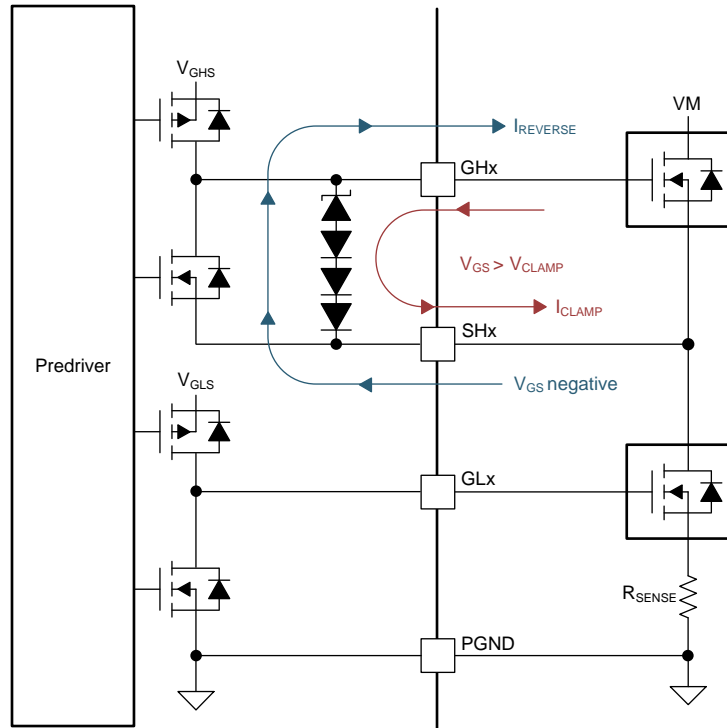

Figure 14. Gate Drive Clamp

7.3.1.4.4 Propagation Delay

The propagation delay time (t_{pd}) is measured as the time between an PWM logic edge detected to the GHX / GLX transition as shown in Figure 13. This time comprises three parts consisting of the digital input deglitcher delay, the digital propagation delay, and the delay through the analog gate drivers.

The input deglitcher prevents high-frequency noise on the input pins from affecting the output state of the gate drivers. To support multiple control modes and dead time insertion, a small digital delay is added as the input command propagates through the device. Lastly, the analog gate drivers have a small delay that contributes to the overall propagation delay of the device.

In order for the output to change state during normal operation, one MOSFET must first be turned off. The MOSFET gate is ramped down according to the IDRIVE setting, and the observed propagation delay ends when the MOSFET gate falls below the threshold voltage.

7.3.1.4.5 MOSFET V_{DS} Monitors

The gate drivers implement adjustable V_{DS} voltage monitors to detect overcurrent or short-circuit conditions on the external power MOSFETs. When the monitored voltage is greater than the V_{DS} trip point (V_{VDS_OCP}) for longer than the deglitch time (t_{OCP}), an overcurrent condition is detected and the driver enters into the V_{DS} automatic-retry mode.

The high-side V_{DS} monitors measure the voltage between the VDRAIN and SHx pins and the low side V_{DS} monitors measure the voltage between the SHx and ISEN pins. The V_{VDS_OCP} threshold is programmable from 0.15 V to 1.8 V. Additional information on the V_{DS} monitor levels are described in the [Pin Diagrams](#) section.

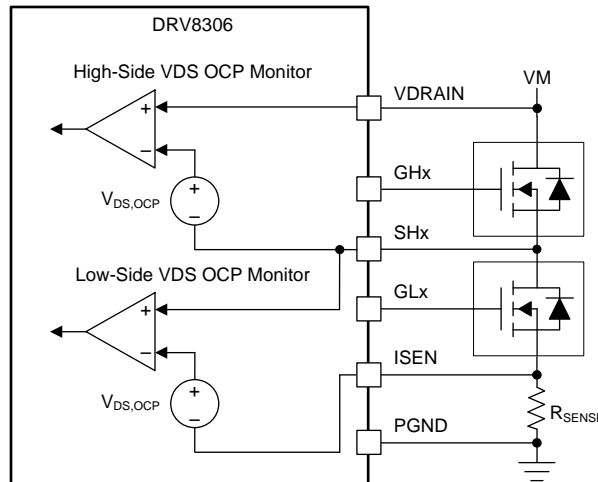

Figure 15. DRV8306 V_{DS} Monitors

7.3.1.4.6 VDRRAIN Sense Pin

The DRV8306 device provides a separate sense pin for the common point of the high-side MOSFET drain. This pin is called VDRRAIN. This pin allows the sense line for the overcurrent monitors (VDRRAIN) and the power supply (VM) to remain separate and prevent noise on the VDRRAIN sense line. This separation also allows for a small filter to be implemented on the gate driver supply (VM) or to insert a boost converter to support lower voltage operation if desired. Care must still be taken when the filter or separate supply is designed because VM is still the reference point for the VCP charge pump that supplies the high-side gate drive voltage ($V_{GS_{SH}}$). The VM supply must not drift too far from the VDRRAIN supply to avoid violating the V_{GS} voltage specification of the external power MOSFETs.

7.3.2 DVDD Linear Voltage Regulator

A 3.3-V, 30-mA linear regulator is integrated into the DRV8306 device and is available for use by external circuitry. This regulator can provide the supply voltage for a low-power microcontroller or other low-current supporting circuitry. The output of the DVDD regulator should be bypassed near the DVDD pin with a X5R or X7R, 1- μ F, 6.3-V ceramic capacitor routed directly back to the adjacent AGND ground pin.

The DVDD nominal, no-load output voltage is 3.3 V. When the DVDD load current exceeds 30 mA, the regulator functions like a constant-current source. The output voltage drops significantly with a current load greater than 30 mA.

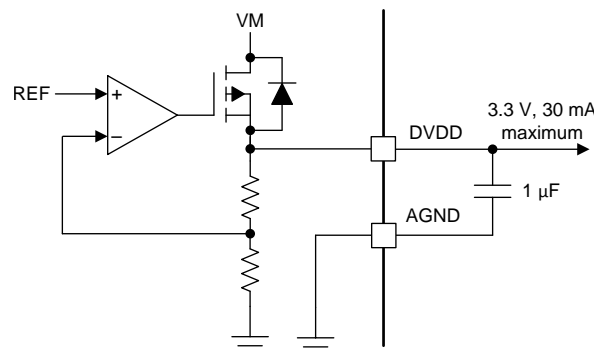

Figure 16. DVDD Linear Regulator Block Diagram

Use Equation 1 to calculate the power dissipated in the device because of the DVDD linear regulator.

$$P = (V_{VM} - V_{DVDD}) \times I_{DVDD} \tag{1}$$

For example, at $V_{VM} = 24$ V, drawing 20 mA out of DVDD results in a power dissipation as shown in Equation 2.

$$P = (24 \text{ V} - 3.3 \text{ V}) \times 20 \text{ mA} = 414 \text{ mW} \quad (2)$$

7.3.3 Pulse-by-Pulse Current Limit

The current-limit circuit activates if the voltage detected across the low-side sense resistor (ISEN pin) exceeds the V_{LIMIT} voltage. This feature restricts motor current to less than the V_{LIMIT} voltage divided by the R_{SENSE} resistance.

NOTE

The current-limit circuit is ignored immediately after the PWM signal goes active for a short blanking time to prevent false trips of the current-limit circuit.

If the current limit activates, the high-side FET is disabled until the beginning of the next PWM cycle. Because the synchronous rectification is always enabled, when the current limit activates, the low-side FET is activated while the high-side FET is disabled.

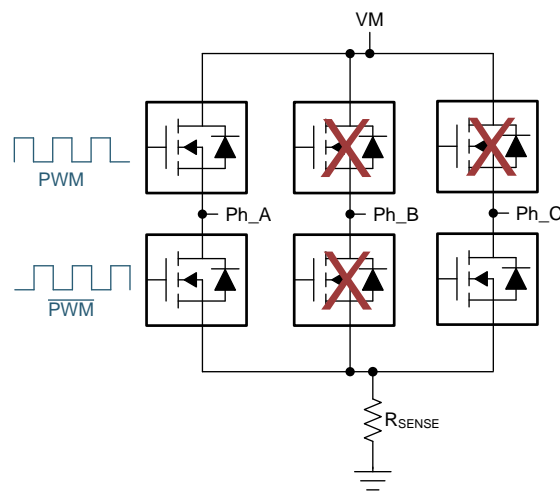

Figure 17. Bridge Operation in Normal Mode (Current Limit Not Active)

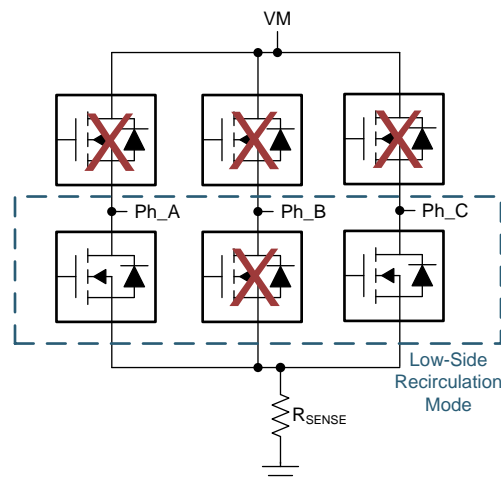

Figure 18. Bridge Operation in Current Limit Mode (Current Limit Active)

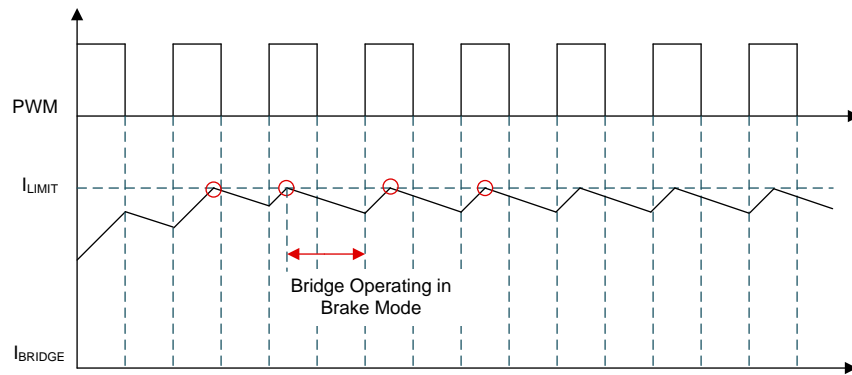

Figure 19. Pulse-by-Pulse Current-Limit Operation

7.3.4 Hall Comparators

Three comparators are provided to process the raw signals from the Hall effect transducers to commutate the motor. The Hall comparators sense zero crossings of the differential inputs and pass the information to digital logic. The Hall comparators have hysteresis, and their detect threshold is centered at 0. The hysteresis is defined as shown in Figure 20.

In addition to the hysteresis, the Hall inputs are deglitched with a circuit that ignores any extra Hall transitions for a period of t_{HDEG} after sensing a valid transition. Ignoring these transitions for the t_{HDEG} time prevents PWM noise from being coupled into the Hall inputs, which can result in erroneous commutation.

If excessive noise is still coupled into the Hall comparator inputs, adding capacitors between the positive and negative inputs of the Hall comparators may be required. The ESD protection circuitry on the Hall inputs implements a diode to the DVDD pin. Because of this diode, the voltage on the Hall inputs should not exceed the DVDD voltage.

Because the DVDD pin is disabled in standby mode (ENABLE inactive), the Hall inputs should not be driven by external voltages in standby mode. If the Hall sensors are powered externally, the supply to the Hall sensors should be disabled if the DRV8306 device is put into standby mode. In addition, the Hall sensor power supply should be powered up after enabling the motor otherwise an invalid Hall state may cause a delay in motor operation.

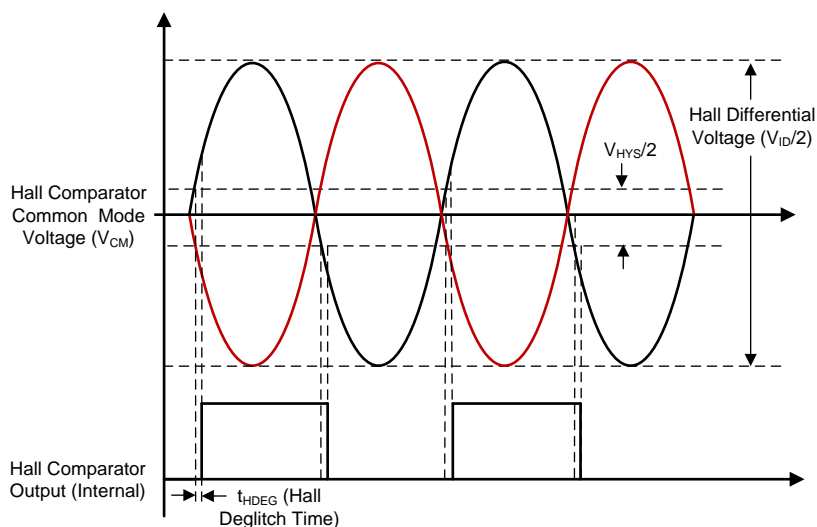

Figure 20. Hall Comparators

7.3.5 FGOUT Signal

The DRV8306 device also has an open-drain FGOUT signal that can be used for the closed-loop speed control of BLDC motor. This signal includes the information of all three Hall-elements inputs as shown in Figure 21.

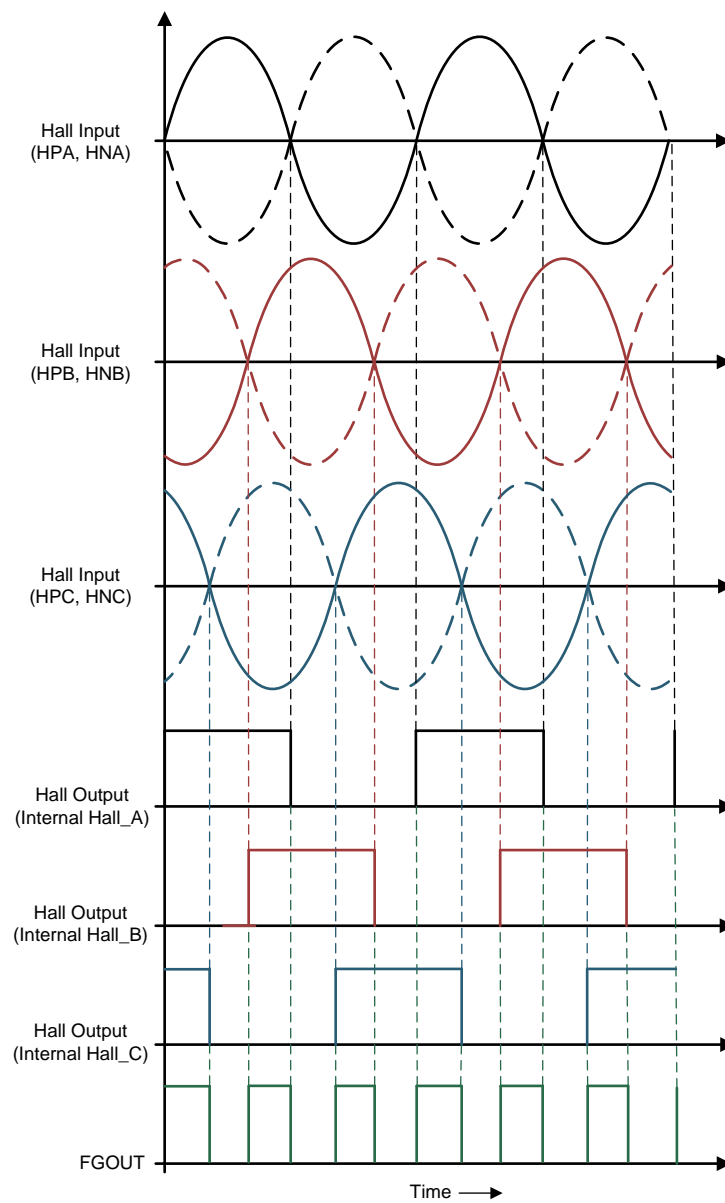

Figure 21. FGOUT Signal

7.3.6 Pin Diagrams

Figure 22 shows the input structure for the logic-level pins, PWM, DIR and nBRAKE. The input can be driven with a voltage or external resistor.

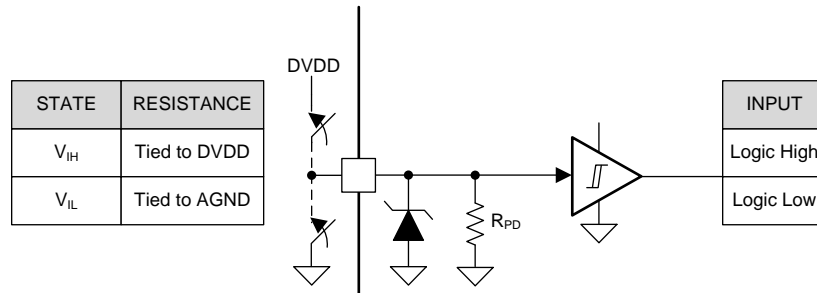

Figure 22. Logic-Level Input Pin Structure (PWM, DIR, and nBRAKE)

Figure 23 shows the input structure for the logic-level pin, ENABLE pin. The input can be driven with a voltage or external resistor. The VEXT represents the external voltage.

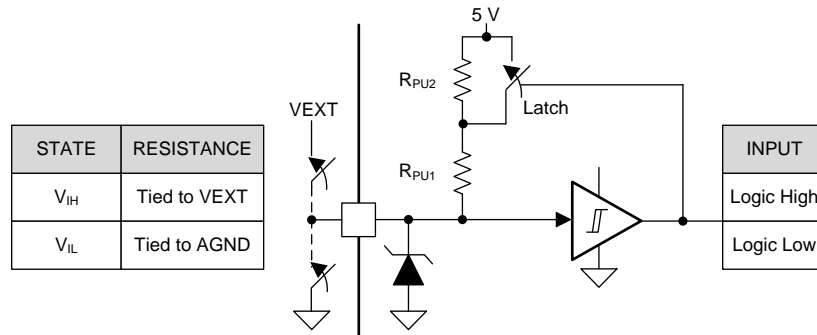

Figure 23. Logic-Level Input Pin Structure (ENABLE)

Figure 24 shows the structure of the open-drain output pin, nFAULT. The open-drain output requires an external pullup resistor to function properly.

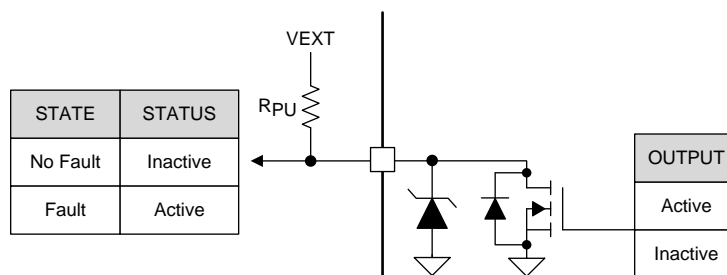

Figure 24. Open-Drain Output Pin Structure

Figure 25 shows the structure of the seven level input pins, IDRIVE and VDS. The input can be set with an external resistor.

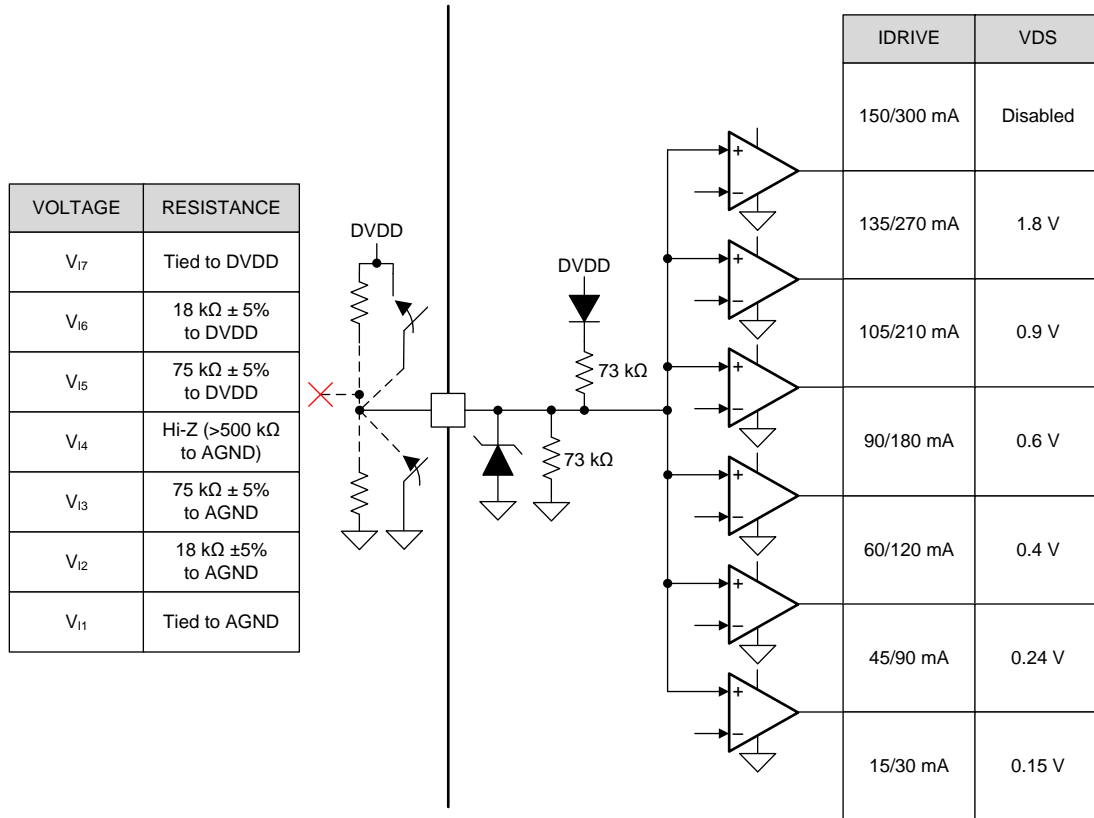

Figure 25. Seven Level Input Pin Structure

7.3.7 Gate-Driver Protective Circuits

The DRV8306 device is fully protected against VM undervoltage, charge pump undervoltage, MOSFET V_{DS} overcurrent, gate driver shorts, and overtemperature events.

Table 3. Fault Action and Response

FAULT	CONDITION	REPORT	GATE DRIVER	LOGIC	RECOVERY
VM undervoltage (UVLO)	$V_{VM} < V_{UVLO}$	nFAULT	Hi-Z	Disabled	Automatic: $V_{VM} > V_{UVLO}$
Charge pump undervoltage (CPUV)	$V_{VCP} < V_{CPUV}$	nFAULT	Hi-Z	Active	Automatic: $V_{VCP} > V_{CPUV}$
V_{DS} overcurrent (VDS_OCP)	$V_{DS} > V_{VDS_OCP}$	nFAULT	Hi-Z	Active	Retry: t_{RETRY}
V_{SENSE} overcurrent (SEN_OCP)	$V_{SP} > V_{SEN_OCP}$	nFAULT	Hi-Z	Active	Retry: t_{RETRY}
Gate driver fault (GDF)	Gate voltage stuck $> t_{DRIVE}$	nFAULT	Hi-Z	Active	Latched: ENABLE Pulse
Thermal shutdown (OTSD)	$T_J > T_{OTSD}$	nFAULT	Hi-Z	Active	Automatic: $T_J < T_{OTSD} - T_{HYS}$

7.3.7.1 VM Supply Undervoltage Lockout (UVLO)

If at any time the input supply voltage on the VM pin falls below the V_{UVLO} threshold, all of the external MOSFETs are disabled, the charge pump is disabled, and the nFAULT pin is driven low. Normal operation resumes (gate driver operation and the nFAULT pin is released) when the VM undervoltage condition is removed.

7.3.7.2 VCP Charge-Pump Undervoltage Lockout (CPUV)

If at any time the voltage on the VCP pin (charge pump) falls below the V_{CPUV} threshold voltage of the charge pump, all of the external MOSFETs are disabled and the nFAULT pin is driven low. Normal operation resumes (gate-driver operation and the nFAULT pin is released) when the VCP undervoltage condition is removed.

7.3.7.3 MOSFET V_{DS} Overcurrent Protection (VDS_OCP)

A MOSFET overcurrent event is sensed by monitoring the V_{DS} voltage drop across the external MOSFET $R_{DS(on)}$. If the voltage across an enabled MOSFET exceeds the V_{VDS_OCP} threshold for longer than the t_{OCP_DEG} deglitch time, a VDS_OCP event is recognized. The V_{VDS_OCP} threshold is set with the VDS pin, the t_{OCP_DEG} is fixed at 4.5 μ s, and the driver operates with fixed for 4-ms automatic retry in an OCP event, but can be disabled by tying the VDS pin to DVDD.

7.3.7.4 V_{SENSE} Overcurrent Protection (SEN_OCP)

Three-phase bridge overcurrent is also monitored by sensing the voltage drop across the external current-sense resistor with the ISEN pin. If at any time the voltage on the ISEN input of the current-sense amplifier exceeds the V_{SEN_OCP} threshold for longer than the t_{OCP_DEG} deglitch time, a SEN_OCP event is recognized. The V_{SEN_OCP} threshold is fixed at 1.8 V, t_{OCP_DEG} is fixed at 4 μ s, and, during the OCP event, the driver operates with fixed t_{RETRY} for 4-ms automatic retry.

7.3.7.5 Gate Driver Fault (GDF)

The GHx and GLx pins are monitored such that if the voltage on the external MOSFET gate does not increase or decrease after the t_{DRIVE} time, a gate driver fault is detected. This fault may be encountered if the GHx or GLx pins are shorted to the PGND, SHx, or VM pins. Additionally, a gate driver fault may be encountered if the selected I_{DRIVE} setting is not sufficient to turn on the external MOSFET within the t_{DRIVE} period. After a gate drive fault is detected, all external MOSFETs are disabled and the nFAULT pin is driven low. Normal operation resumes (gate driver operation and the nFAULT pin is released) when the gate driver fault condition is removed.

Gate driver faults can indicate that the selected I_{DRIVE} or t_{DRIVE} settings are too low to slew the external MOSFET in the desired time. Increasing either the I_{DRIVE} or t_{DRIVE} setting can resolve gate driver faults in these cases. Alternatively, if a gate-to-source short occurs on the external MOSFET, a gate driver fault is reported because of the MOSFET gate not turning on.

7.3.7.6 Thermal Shutdown (OTSD)

If the die temperature exceeds the trip point of the thermal shutdown limit (T_{OTSD}), all the external MOSFETs are disabled, the charge pump is shut down, and the nFAULT pin is driven low. Normal operation resumes (gate driver operation and the nFAULT pin is released) when the overtemperature condition is removed. This protection feature cannot be disabled.

7.4 Device Functional Modes

7.4.1 Gate Driver Functional Modes

7.4.1.1 Sleep Mode

The ENABLE pin manages the state of the DRV8306 device. When the ENABLE pin is low, the device goes to a low-power sleep mode. In sleep mode, all gate drivers are disabled, all external MOSFETs are disabled, the charge pump is disabled, and the DVDD regulator is disabled. The t_{SLEEP} time must elapse after a falling edge on the ENABLE pin before the device goes to the sleep mode. The device goes from the sleep mode automatically if the ENABLE pin is pulled high. The t_{WAKE} time must elapse before the device is ready for inputs.

In sleep mode and when $V_{VM} < V_{UVLO}$, all external MOSFETs are disabled. The high-side gate pins, GHx, are pulled to the SHx pin by an internal resistor and the low-side gate pins, GLx, are pulled to the PGND pin by an internal resistor.

NOTE

During power up and power down of the device through the ENABLE pin, the nFAULT pin is held low as the internal regulators are enabled or disabled. After the regulators have enabled or disabled, the nFAULT pin is automatically released. The duration that the nFAULT pin is low does not exceed the t_{SLEEP} or t_{WAKE} time.

7.4.1.2 Operating Mode

When the ENABLE pin is high or left floating and $V_{VM} > V_{UVLO}$, the device goes to the operating mode. The t_{WAKE} time must elapse before the device is ready for inputs. In this mode the charge pump, low-side gate regulator, and DVDD regulator are active. The hardware inputs (IDRIVE and VDS) are latched during the wake-up time (t_{WAKE}). Any further change to these pins is ignored unless a power-up cycle or an ENABLE pin transition after sleep mode occurs.

7.4.1.3 Fault Reset (ENABLE Reset Pulse)

In the case of device-latched faults, the DRV8306 device goes to driver Hi-Z state to help protect the external power MOSFETs and system.

When the fault condition is removed the device can go back to the operating state by issuing a reset pulse to the ENABLE pin on either interface variant. The ENABLE reset pulse (t_{RST}) consists of a high-to-low-to-high transition on the ENABLE pin. The low period of the sequence should fall with the t_{RST} time window or else the device will begin the complete shutdown sequence. The reset pulse has no effect on any of the regulators, device settings, or other functional blocks

8 Application and Implementation

NOTE

Information in the following applications sections is not part of the TI component specification, and TI does not warrant its accuracy or completeness. TI's customers are responsible for determining suitability of components for their purposes. Customers should validate and test their design implementation to confirm system functionality.

8.1 Application Information

The DRV8306 device is primarily used in three-phase brushless DC motor-control applications. The design procedures in the [Typical Application](#) section highlight how to use and configure the DRV8306 device.

8.1.1 Hall Sensor Configuration and Connection

The combinations of Hall sensor connections in this section are common connections.

8.1.1.1 Typical Configuration

The Hall sensor inputs on the DRV8306 device can interface with a variety of Hall sensors. Typically, a Hall element is used, which outputs a differential signal on the order of 100 mV. To use this type of sensor, the DVDD regulator can be used to power the Hall sensor. [Figure 26](#) shows the connections.

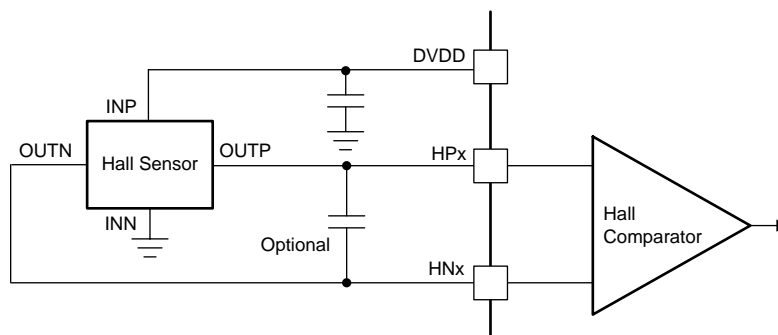

Figure 26. Typical Hall Sensor Configuration

Because the amplitude of the Hall-sensor output signal is very low, capacitors are often placed across the Hall inputs to help reject noise coupled from the motor. Capacitors with a value of 1 nF to 100 nF are typically used.

8.1.1.2 Open Drain Configuration

Some motors use digital Hall sensors with open-drain outputs. These sensors can also be used with the DRV8306 device, with the addition of a few resistors as shown in [Figure 27](#).

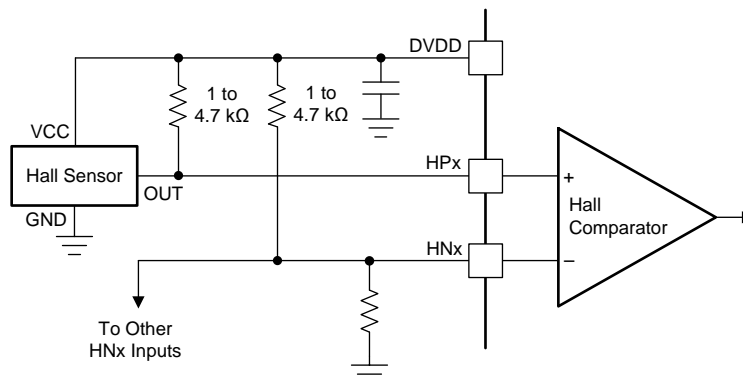

Figure 27. Open-Drain Hall Sensor Configuration

Application Information (continued)

The negative (HNx) inputs are biased to $DVDD / 2$ by a pair of resistors between the DVDD pin and ground. For open-collector Hall sensors, an additional pullup resistor to the VREG pin is required on the positive (HPx) input. Again, the DVDD output can usually be used to supply power to the Hall sensors.

8.1.1.3 Series Configuration

Hall elements are also connected in series or parallel depending upon the Hall sensor current/voltage requirement. Figure 28 shows the series connection of Hall sensors powered via the DRV8306 internal LDO (DVDD). This configuration is used if the current requirement per Hall sensor is high (>10 mA)

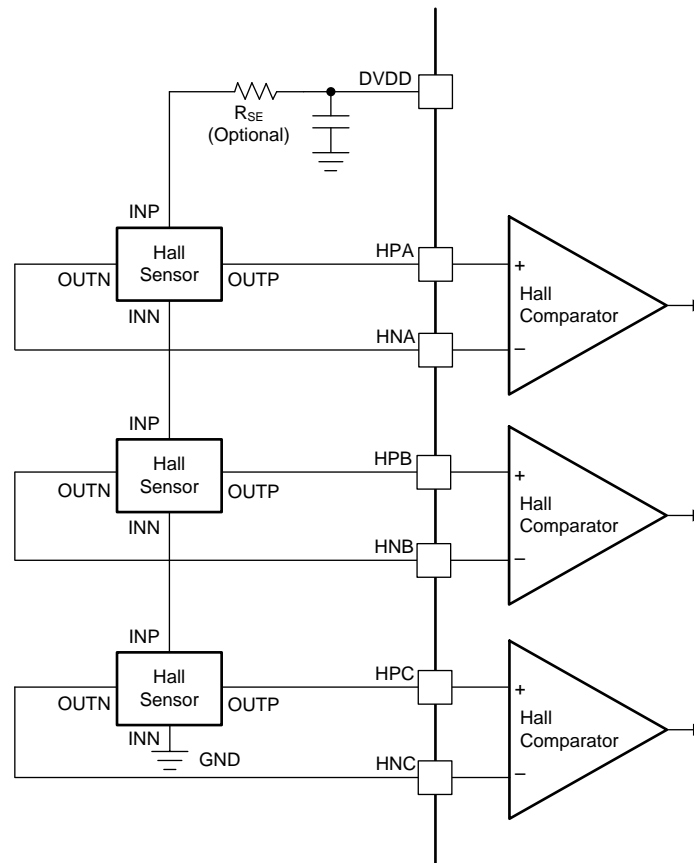

Figure 28. Hall Sensor Connected in Series Configuration

Application Information (continued)

8.1.1.4 Parallel Configuration

Figure 29 shows the parallel connection of Hall sensors which is powered by the DVDD. This configuration can be used if the current requirement per Hall sensor is low (<10 mA).

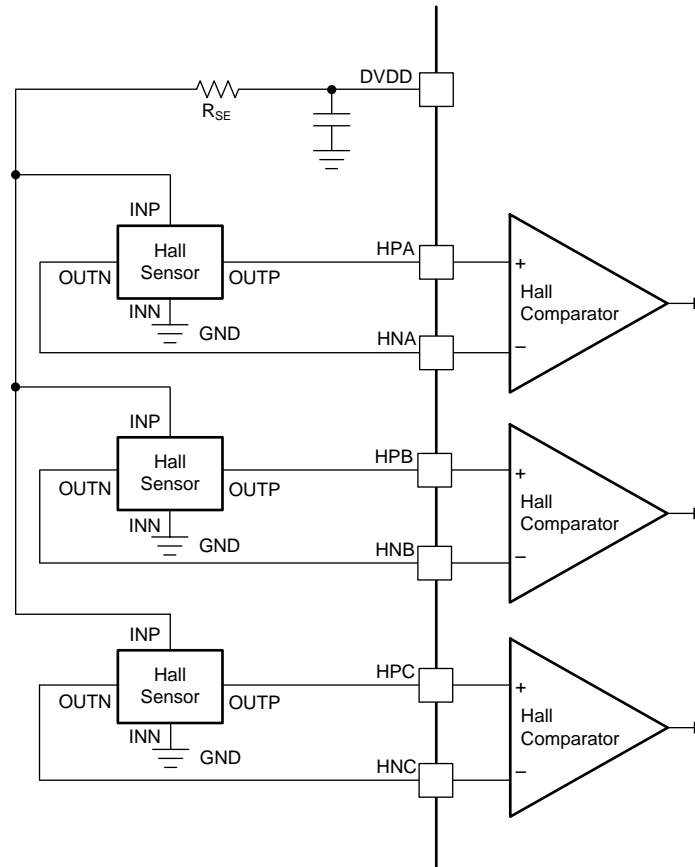

Figure 29. Hall Sensors Connected in Parallel Configuration

8.2 Typical Application

8.2.1 Primary Application

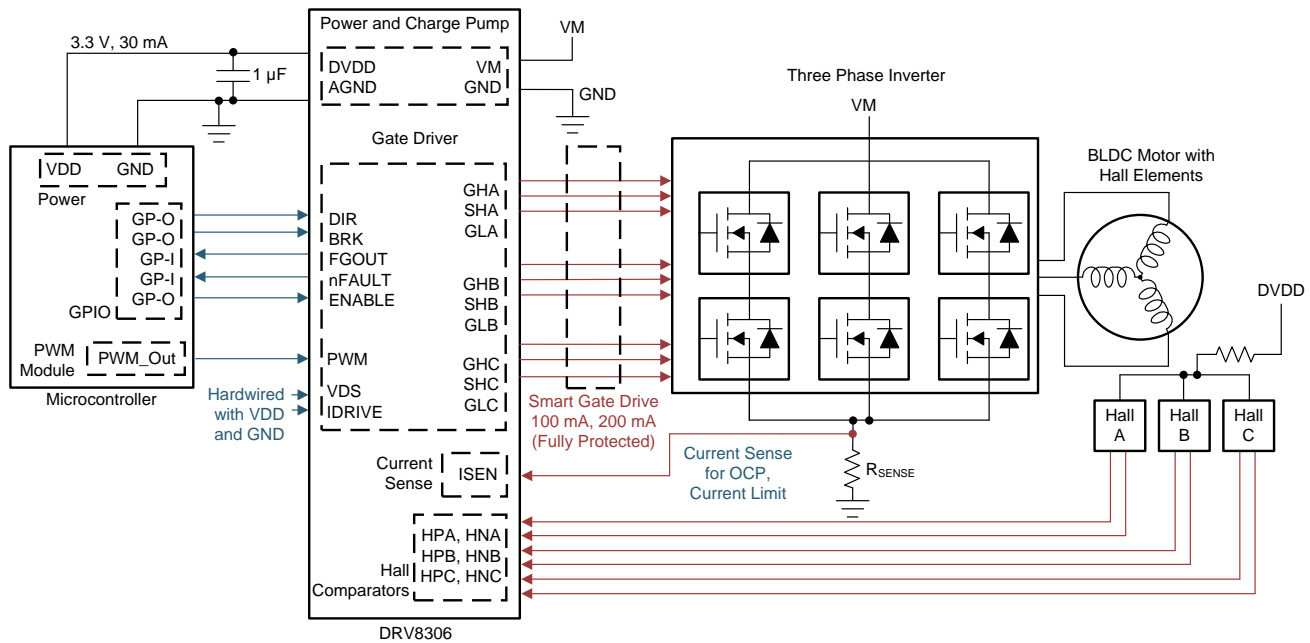

Figure 30. Primary Application Schematic

8.2.1.1 Design Requirements

Table 4 lists the example input parameters for the system design.

Table 4. Design Parameters

EXAMPLE DESIGN PARAMETER	REFERENCE	EXAMPLE VALUE
Nominal supply voltage	V_{VM}	24 V
Supply voltage range		8 V to 38 V
MOSFET part number		CSD18514Q5A
MOSFET total gate charge	Q_g	29 nC (typical) at $V_{VGS} = 10$ V
MOSFET gate to drain charge	Q_{gd}	5 nC (typical)
Target output rise time	t_r	100 to 300 ns
Target output fall time	t_f	50 to 150 ns
PWM frequency	f_{PWM}	45 kHz
Maximum motor current	I_{max}	50 A
Winding sense current range	I_{SENSE}	-20 A to +20 A
Motor RMS current	I_{RMS}	14.14 A
Sense resistor power rating	P_{SENSE}	2 W
System ambient temperature	T_A	-20°C to +105°C

8.2.1.2 Detailed Design Procedure

8.2.1.2.1 External MOSFET Support

The DRV8306 MOSFET support is based on the charge-pump capacity and output PWM switching frequency. For a quick calculation of MOSFET driving capacity, use [Equation 3](#) for three-phase BLDC motor applications.

Trapezoidal 120° Commutation: $I_{VCP} > Q_g \times f_{PWM}$

where

- f_{PWM} is the maximum desired PWM switching frequency.
- I_{VCP} is the charge pump capacity, which depends on the VM pin voltage.
- The multiplier based on the commutation control method, may vary based on implementation. (3)

8.2.1.2.1.1 Example

If a system at $V_{VM} = 8\text{ V}$ ($I_{VCP} = 15\text{ mA}$) uses a maximum PWM switching frequency of 45 kHz, then the charge-pump can support MOSFETs using trapezoidal commutation with a $Q_g < 333\text{ nC}$. When the VM voltage (V_{VM}) is 8 V, the maximum DRV8306 gate drive voltage (V_{GSH}) is 7.3 V. Therefore, at 7.3-V gate drive, the target FET (part number CSD18514Q5A) only has a gate charge of approximately 22 nC. Therefore, with this FET, the system can have an adequate margin.

8.2.1.2.2 IDRIVE Configuration

The gate drive current strength, I_{DRIVE} , is selected based on the gate-to-drain charge of the external MOSFETs and the target rise and fall times at the outputs. If I_{DRIVE} is selected to be too low for a given MOSFET, then the MOSFET may not turn on completely within the t_{DRIVE} time and a gate drive fault may be asserted. Additionally, slow rise and fall times will lead to higher switching power losses. TI recommends adjusting these values in the system with the required external MOSFETs and motor to determine the best possible setting for any application.

The I_{DRIVEP} and I_{DRIVEN} current for both the low-side and high-side MOSFETs are selected simultaneously on the IDRIVE pin.

For MOSFETs with a known gate-to-drain charge Q_{gd} , desired rise time (t_r), and a desired fall time (t_f), use [Equation 4](#) and [Equation 5](#) to calculate the value of I_{DRIVEP} and I_{DRIVEN} (respectively).

$$I_{DRIVEP} = \frac{Q_{gd}}{t_r} \quad (4)$$

$$I_{DRIVEN} = \frac{Q_{gd}}{t_f} \quad (5)$$

8.2.1.2.2.1 Example

Use [Equation 6](#) and [Equation 7](#) to calculate the value of $I_{DRIVEP1}$ and $I_{DRIVEP2}$ (respectively) for a gate to drain charge of 5 nC and a rise time from 100 to 300 ns.

$$I_{DRIVEP1} = \frac{5\text{ nC}}{100\text{ ns}} = 50\text{ mA} \quad (6)$$

$$I_{DRIVEP2} = \frac{5\text{ nC}}{300\text{ ns}} = 16.67\text{ mA} \quad (7)$$

Select a value for I_{DRIVEP} that is between 16.67 mA and 50 mA. For this example, the value of I_{DRIVEP} was selected as 45-mA source.

Use [Equation 8](#) and [Equation 9](#) to calculate the value of $I_{DRIVEN1}$ and $I_{DRIVEN2}$ (respectively) for a gate to drain charge of 5 nC and a fall time from 50 to 150 ns.

$$I_{DRIVEN1} = \frac{5\text{ nC}}{50\text{ ns}} = 100\text{ mA} \quad (8)$$

$$I_{DRIVEN2} = \frac{5\text{ nC}}{150\text{ ns}} = 33.33\text{ mA} \quad (9)$$

Select a value for I_{DRIVEN} that is between 33.33 mA and 100 mA. For this example, the value of I_{DRIVEN} was selected as 90-mA sink.

8.2.1.2.3 V_{DS} Overcurrent Monitor Configuration

The V_{DS} monitors are configured based on the worst-case motor current and the $R_{\text{DS(on)}}$ of the external MOSFETs as shown in [Equation 10](#).

$$V_{\text{DS_OCP}} > I_{\text{max}} \times R_{\text{DS(on)max}} \quad (10)$$

8.2.1.2.3.1 Example

The goal of this example is to set the V_{DS} monitor to trip at a current greater than 50 A. According to the [CSD18514Q5A 40 V N-Channel NexFET™ Power MOSFET data sheet](#), the $R_{\text{DS(on)}}$ value is 1.8 times higher at 175°C, and the maximum $R_{\text{DS(on)}}$ value at a V_{GS} of 10 V is 4.9 mΩ. From these values, the approximate worst-case value of $R_{\text{DS(on)}}$ is $1.8 \times 4.9 \text{ m}\Omega = 8.82 \text{ m}\Omega$.

Using [Equation 10](#) with a value of 8.82 mΩ for $R_{\text{DS(on)}}$ and a worst-case motor current of 50 A, [Equation 11](#) shows the calculated the value of the V_{DS} monitors.

$$\begin{aligned} V_{\text{DS_OCP}} &> 50 \text{ A} \times 8.82 \text{ m}\Omega \\ V_{\text{DS_OCP}} &> 0.441 \text{ V} \end{aligned} \quad (11)$$

For this example, the value of $V_{\text{DS_OCP}}$ was selected as 0.51 V.

The deglitch time for the V_{DS} overcurrent monitor is fixed at 4 μs.

8.2.1.3 Application Curves

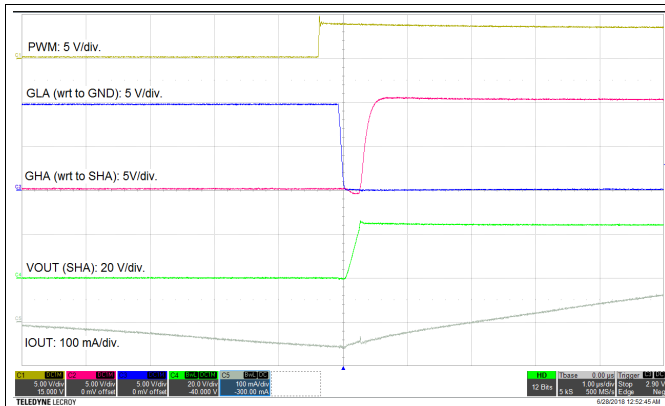

Figure 31. IDRIVE Maximum Setting

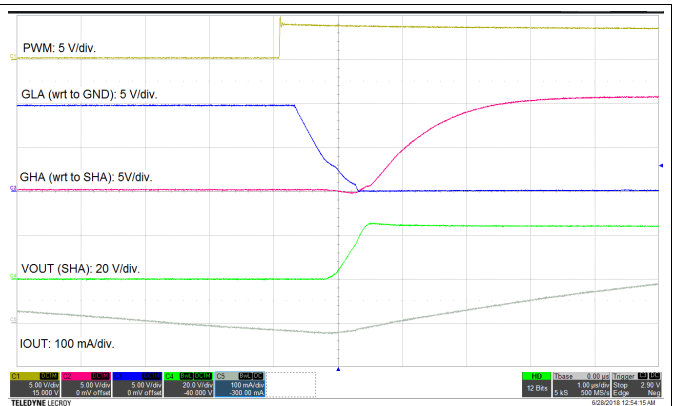

Figure 32. IDRIVE Minimum Setting

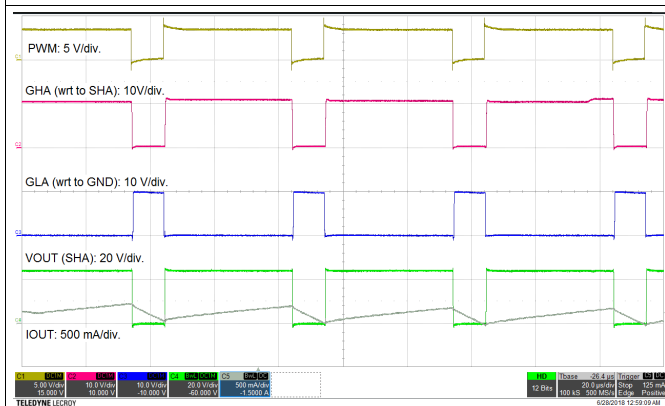

Figure 33. Gate Drive 80% Duty Cycle

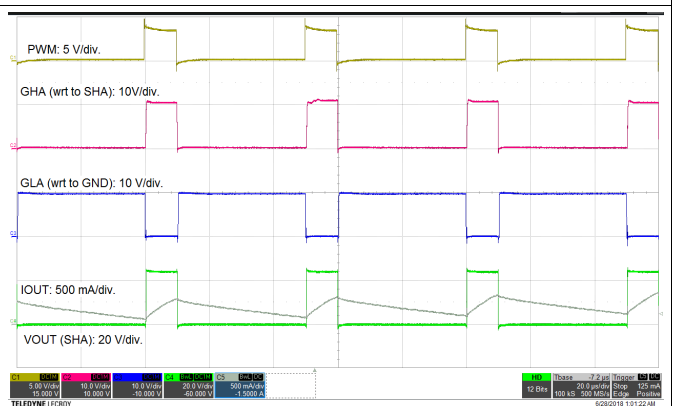

Figure 34. Gate Drive 20% Duty Cycle

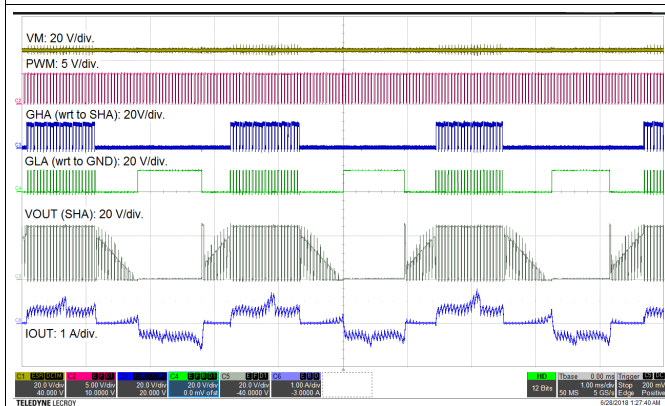

Figure 35. Motor Operation at 80% PWM Duty

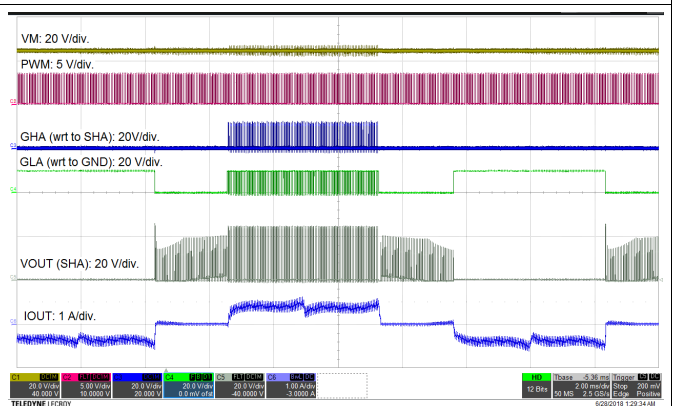

Figure 36. Motor Operation at 20% PWM Duty

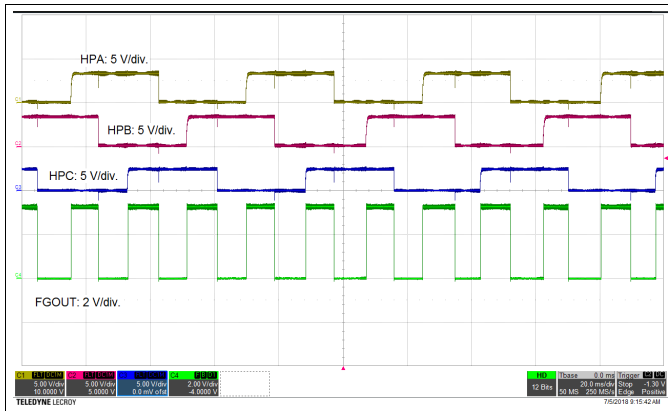

Figure 37. Hall Operation (Digital Hall Sensors Connected)

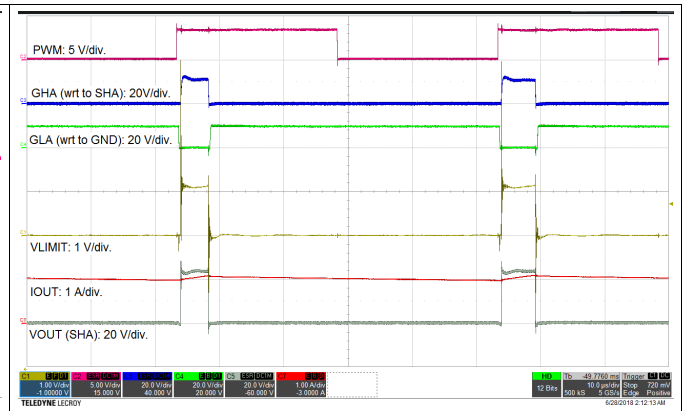

Figure 38. VLIMIT Operation

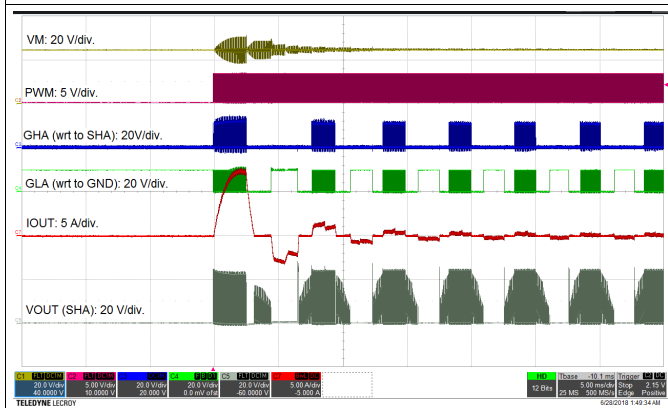

Figure 39. Motor Starting With PWM Duty Change

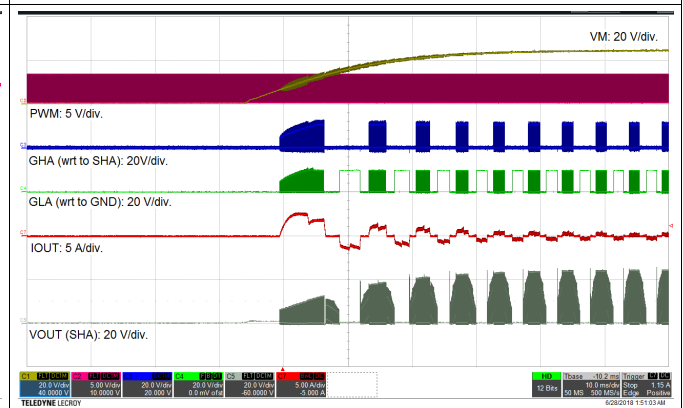

Figure 40. Motor Starting With Supply Voltage Change

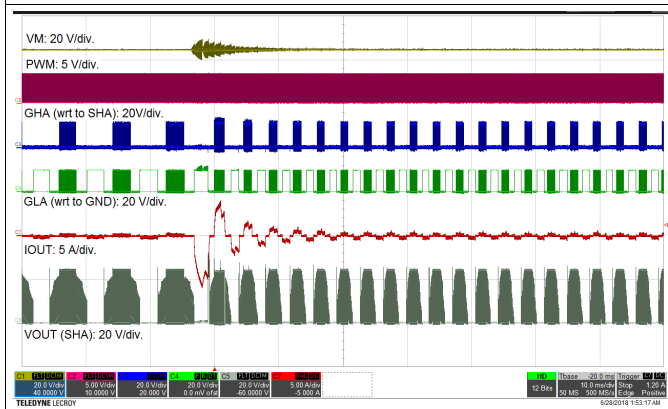

Figure 41. Motor Performance at Speed Change

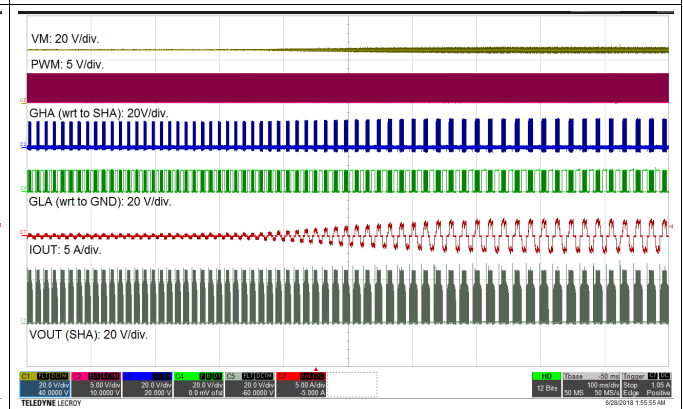

Figure 42. Motor Performance at Load Change

9 Power Supply Recommendations

The DRV8306 device is designed to operate from an input voltage supply (VM) range from 6 V to 38 V. A 0.1- μF ceramic capacitor rated for VM must be placed as close to the device as possible. In addition, a bulk capacitor must be included on the VM pin but can be shared with the bulk bypass capacitance for the external power MOSFETs. Additional bulk capacitance is required to bypass the external half-bridge MOSFETs and should be sized according to the application requirements.

9.1 Bulk Capacitance Sizing

Having appropriate local bulk capacitance is an important factor in motor drive system design. It is generally beneficial to have more bulk capacitance, while the disadvantages are increased cost and physical size. The amount of local capacitance depends on a variety of factors including:

- The highest current required by the motor system
- The power supply's type, capacitance, and ability to source current
- The amount of parasitic inductance between the power supply and motor system
- The acceptable supply voltage ripple
- Type of motor (brushed DC, brushless DC, stepper)
- The motor startup and braking methods

The inductance between the power supply and motor drive system will limit the rate current can change from the power supply. If the local bulk capacitance is too small, the system will respond to excessive current demands or dumps from the motor with a change in voltage. When adequate bulk capacitance is used, the motor voltage remains stable and high current can be quickly supplied.

The data sheet provides a recommended minimum value, but system level testing is required to determine the appropriate sized bulk capacitor.

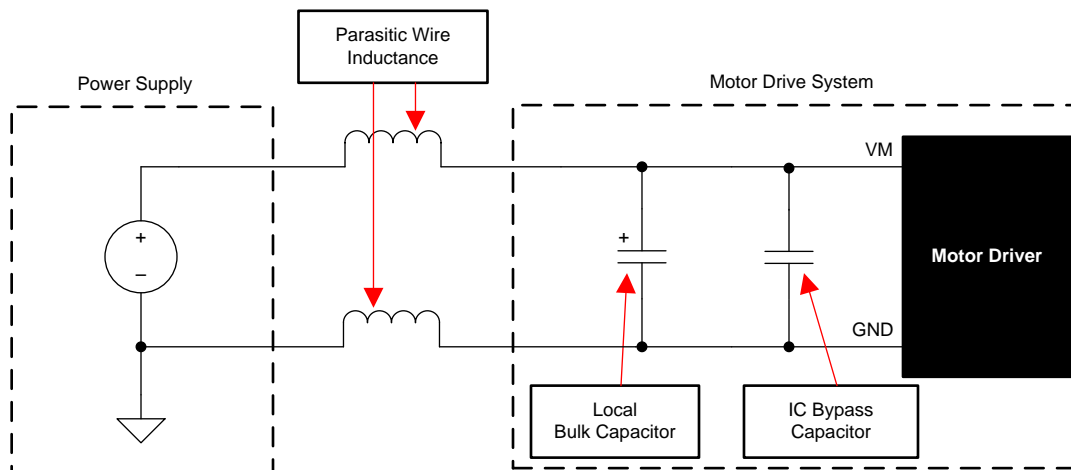

Figure 43. Motor Drive Supply Parasitics Example

10 Layout

10.1 Layout Guidelines

Bypass the VM pin to the PGND pin using a low-ESR ceramic bypass capacitor with a recommended value of 0.1 μF . Place this capacitor as close to the VM pin as possible with a thick trace or ground plane connected to the PGND pin. Additionally, bypass the VM pin using a bulk capacitor rated for VM. This component can be electrolytic. This capacitance must be at least 10 μF .

Additional bulk capacitance is required to bypass the high current path on the external MOSFETs. This bulk capacitance should be placed such that it minimizes the length of any high current paths through the external MOSFETs. The connecting metal traces should be as wide as possible, with numerous vias connecting PCB layers. These practices minimize inductance and let the bulk capacitor deliver high current.

Place a low-ESR ceramic capacitor between the CPL and CPH pins. This capacitor should be 47 nF, rated for VM, and be of type X5R or X7R. Additionally, place a low-ESR ceramic capacitor between the VCP and VM pins. This capacitor should be 1 μF , rated for 16 V, and be of type X5R or X7R.

Bypass the DVDD pin to the AGND pin with a 1- μF low-ESR ceramic capacitor rated for 6.3 V and of type X5R or X7R. Place this capacitor as close to the pin as possible and minimize the path from the capacitor to the AGND pin.

The VDRAIN pin can be shorted directly to the VM pin. However, if a significant distance is between the device and the external MOSFETs, use a dedicated trace to connect to the common point of the drains of the high-side external MOSFETs. Do not connect the SLx pins directly to PGND. Instead, use dedicated traces to connect these pins to the sources of the low-side external MOSFETs. These recommendations offer more accurate V_{DS} sensing of the external MOSFETs for overcurrent detection.

Minimize the loop length for the high-side and low-side gate drivers. The high-side loop is from the GHx pin of the device to the high-side power MOSFET gate, then follows the high-side MOSFET source back to the SHx pin. The low-side loop is from the GLx pin of the device to the low-side power MOSFET gate, then follows the low-side MOSFET source back to the PGND pin.

10.2 Layout Example

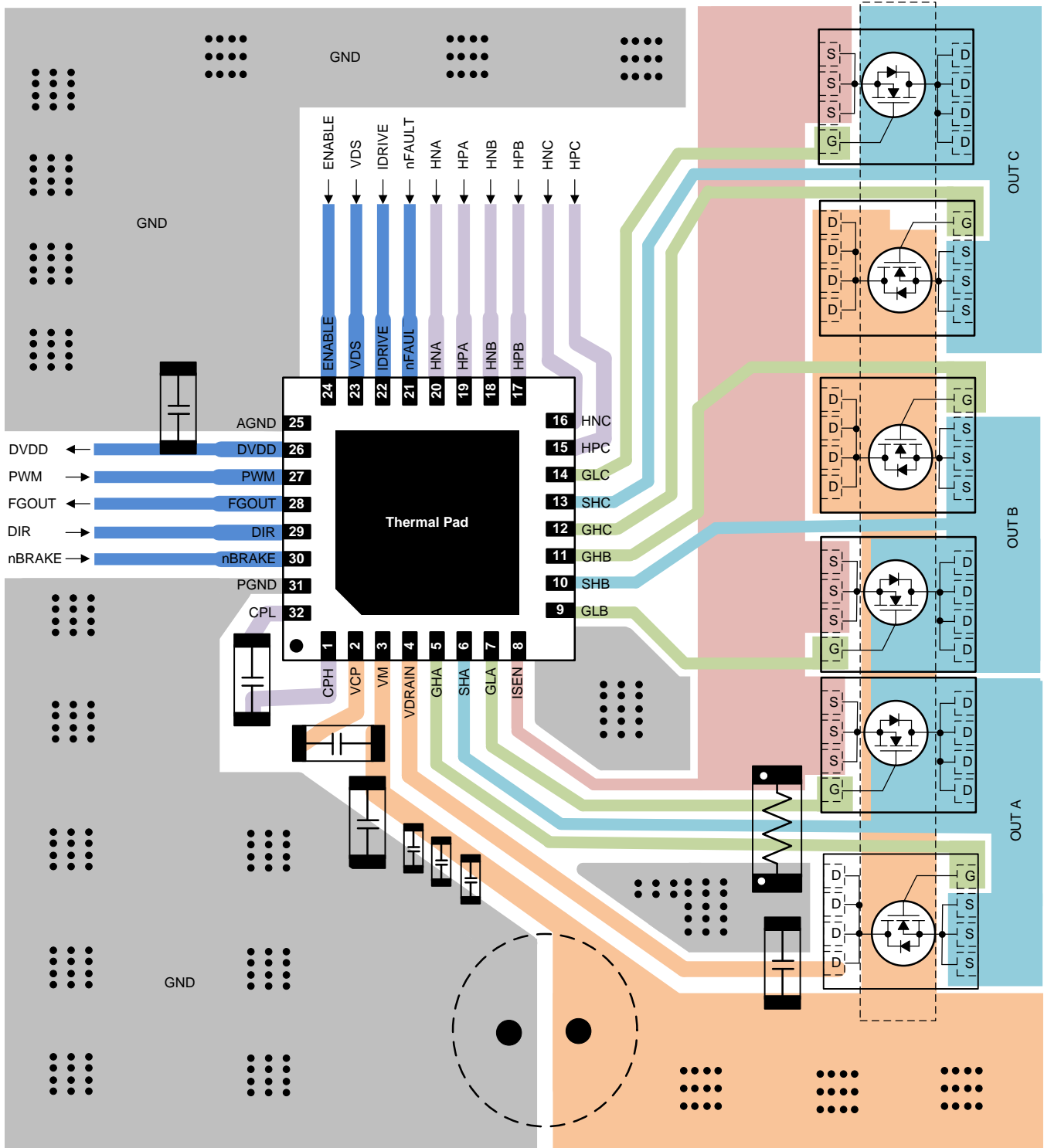

Figure 44. Layout Example

11 Device and Documentation Support

11.1 Device Support

11.1.1 Device Nomenclature

The following figure shows a legend for interpreting the complete device name:

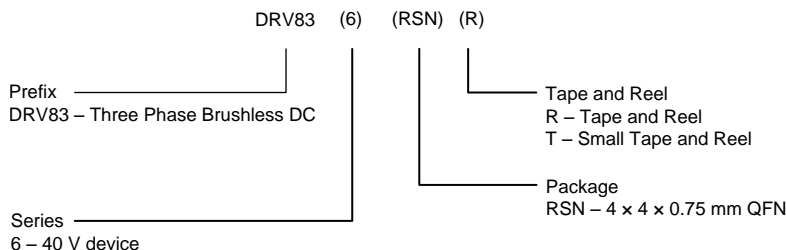

11.2 Documentation Support

11.2.1 Related Documentation

For related documentation see the following:

- Texas Instruments, [AN-1149 Layout Guidelines for Switching Power Supplies application report](#)
- Texas Instruments, [DRV8306EVM User's Guide](#)
- Texas Instruments, [Hardware Design Considerations for an Efficient Vacuum Cleaner using BLDC Motor application report](#)
- Texas Instruments, [Hardware Design Considerations for an Electric Bicycle using BLDC Motor application report](#)
- Texas Instruments, [Industrial Motor Drive Solution Guide](#)
- Texas Instruments, [Layout Guidelines for Switching Power Supplies application report](#)
- Texas Instruments, [Motor Drive Protection with TI Smart Gate Drive TI TechNote](#)
- Texas Instruments, [QFN/SON PCB Attachment application report](#)
- Texas Instruments, [Reduce Motor Drive BOM and PCB Area with TI Smart Gate Drive TI TechNote](#)
- Texas Instruments, [Sensored 3-Phase BLDC Motor Control Using MSP430™ application report](#)
- Texas Instruments, [Understanding IDRIVE and TDRIVE In TI Motor Gate Drivers application report](#)

11.3 Receiving Notification of Documentation Updates

To receive notification of documentation updates, navigate to the device product folder on ti.com. In the upper right corner, click on *Alert me* to register and receive a weekly digest of any product information that has changed. For change details, review the revision history included in any revised document.

11.4 Community Resources

The following links connect to TI community resources. Linked contents are provided "AS IS" by the respective contributors. They do not constitute TI specifications and do not necessarily reflect TI's views; see TI's [Terms of Use](#).

TI E2E™ Online Community *TI's Engineer-to-Engineer (E2E) Community*. Created to foster collaboration among engineers. At e2e.ti.com, you can ask questions, share knowledge, explore ideas and help solve problems with fellow engineers.

Design Support *TI's Design Support* Quickly find helpful E2E forums along with design support tools and contact information for technical support.

11.5 Trademarks

NexFET, MSP430, E2E are trademarks of Texas Instruments.
All other trademarks are the property of their respective owners.

11.6 Electrostatic Discharge Caution



This integrated circuit can be damaged by ESD. Texas Instruments recommends that all integrated circuits be handled with appropriate precautions. Failure to observe proper handling and installation procedures can cause damage.

ESD damage can range from subtle performance degradation to complete device failure. Precision integrated circuits may be more susceptible to damage because very small parametric changes could cause the device not to meet its published specifications.

11.7 Glossary



[SLYZ022](#) — *TI Glossary*.

This glossary lists and explains terms, acronyms, and definitions.

12 Mechanical, Packaging, and Orderable Information

The following pages include mechanical, packaging, and orderable information. This information is the most current data available for the designated devices. This data is subject to change without notice and revision of this document. For browser-based versions of this data sheet, refer to the left-hand navigation.

PACKAGING INFORMATION

Orderable Device	Status (1)	Package Type	Package Drawing	Pins	Package Qty	Eco Plan (2)	Lead finish/ Ball material (6)	MSL Peak Temp (3)	Op Temp (°C)	Device Marking (4/5)	Samples
DRV8306HRSMR	ACTIVE	VQFN	RSM	32	3000	RoHS & Green	NIPDAU	Level-1-260C-UNLIM	-40 to 125	DRV 8306H	
DRV8306HRSMT	ACTIVE	VQFN	RSM	32	250	RoHS & Green	NIPDAU	Level-1-260C-UNLIM	-40 to 125	DRV 8306H	

(1) The marketing status values are defined as follows:

ACTIVE: Product device recommended for new designs.

LIFEBUY: TI has announced that the device will be discontinued, and a lifetime-buy period is in effect.

NRND: Not recommended for new designs. Device is in production to support existing customers, but TI does not recommend using this part in a new design.

PREVIEW: Device has been announced but is not in production. Samples may or may not be available.

OBSOLETE: TI has discontinued the production of the device.

(2) **RoHS:** TI defines "RoHS" to mean semiconductor products that are compliant with the current EU RoHS requirements for all 10 RoHS substances, including the requirement that RoHS substance do not exceed 0.1% by weight in homogeneous materials. Where designed to be soldered at high temperatures, "RoHS" products are suitable for use in specified lead-free processes. TI may reference these types of products as "Pb-Free".

RoHS Exempt: TI defines "RoHS Exempt" to mean products that contain lead but are compliant with EU RoHS pursuant to a specific EU RoHS exemption.

Green: TI defines "Green" to mean the content of Chlorine (Cl) and Bromine (Br) based flame retardants meet JS709B low halogen requirements of <=1000ppm threshold. Antimony trioxide based flame retardants must also meet the <=1000ppm threshold requirement.

(3) MSL, Peak Temp. - The Moisture Sensitivity Level rating according to the JEDEC industry standard classifications, and peak solder temperature.

(4) There may be additional marking, which relates to the logo, the lot trace code information, or the environmental category on the device.

(5) Multiple Device Markings will be inside parentheses. Only one Device Marking contained in parentheses and separated by a "~" will appear on a device. If a line is indented then it is a continuation of the previous line and the two combined represent the entire Device Marking for that device.

(6) Lead finish/Ball material - Orderable Devices may have multiple material finish options. Finish options are separated by a vertical ruled line. Lead finish/Ball material values may wrap to two lines if the finish value exceeds the maximum column width.

Important Information and Disclaimer:The information provided on this page represents TI's knowledge and belief as of the date that it is provided. TI bases its knowledge and belief on information provided by third parties, and makes no representation or warranty as to the accuracy of such information. Efforts are underway to better integrate information from third parties. TI has taken and continues to take reasonable steps to provide representative and accurate information but may not have conducted destructive testing or chemical analysis on incoming materials and chemicals. TI and TI suppliers consider certain information to be proprietary, and thus CAS numbers and other limited information may not be available for release.

In no event shall TI's liability arising out of such information exceed the total purchase price of the TI part(s) at issue in this document sold by TI to Customer on an annual basis.

TAPE AND REEL INFORMATION



QUADRANT ASSIGNMENTS FOR PIN 1 ORIENTATION IN TAPE



*All dimensions are nominal

Device	Package Type	Package Drawing	Pins	SPQ	Reel Diameter (mm)	Reel Width W1 (mm)	A0 (mm)	B0 (mm)	K0 (mm)	P1 (mm)	W (mm)	Pin1 Quadrant
DRV8306HRSMR	VQFN	RSM	32	3000	330.0	12.4	4.25	4.25	1.15	8.0	12.0	Q2
DRV8306HRSMT	VQFN	RSM	32	250	180.0	12.4	4.25	4.25	1.15	8.0	12.0	Q2

TAPE AND REEL BOX DIMENSIONS

*All dimensions are nominal

Device	Package Type	Package Drawing	Pins	SPQ	Length (mm)	Width (mm)	Height (mm)
DRV8306HRSMR	VQFN	RSM	32	3000	367.0	367.0	35.0
DRV8306HRSMT	VQFN	RSM	32	250	210.0	185.0	35.0

GENERIC PACKAGE VIEW

RSM 32

VQFN - 1 mm max height

4 x 4, 0.4 mm pitch

PLASTIC QUAD FLATPACK - NO LEAD

This image is a representation of the package family, actual package may vary.
Refer to the product data sheet for package details.

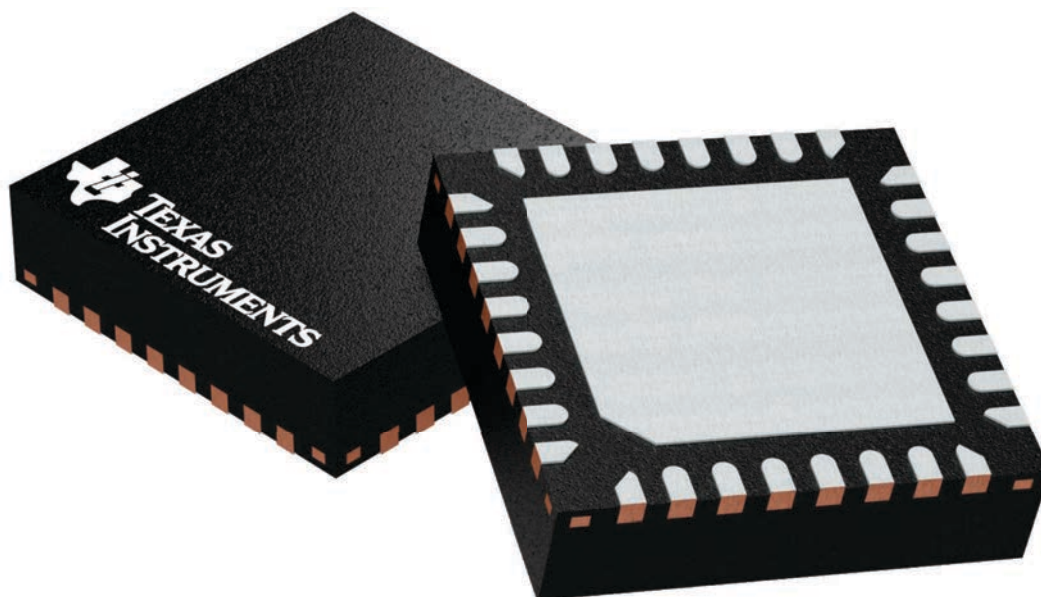

4224982/A

RSM0032B

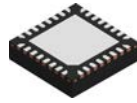

PACKAGE OUTLINE

VQFN - 1 mm max height

PLASTIC QUAD FLATPACK - NO LEAD

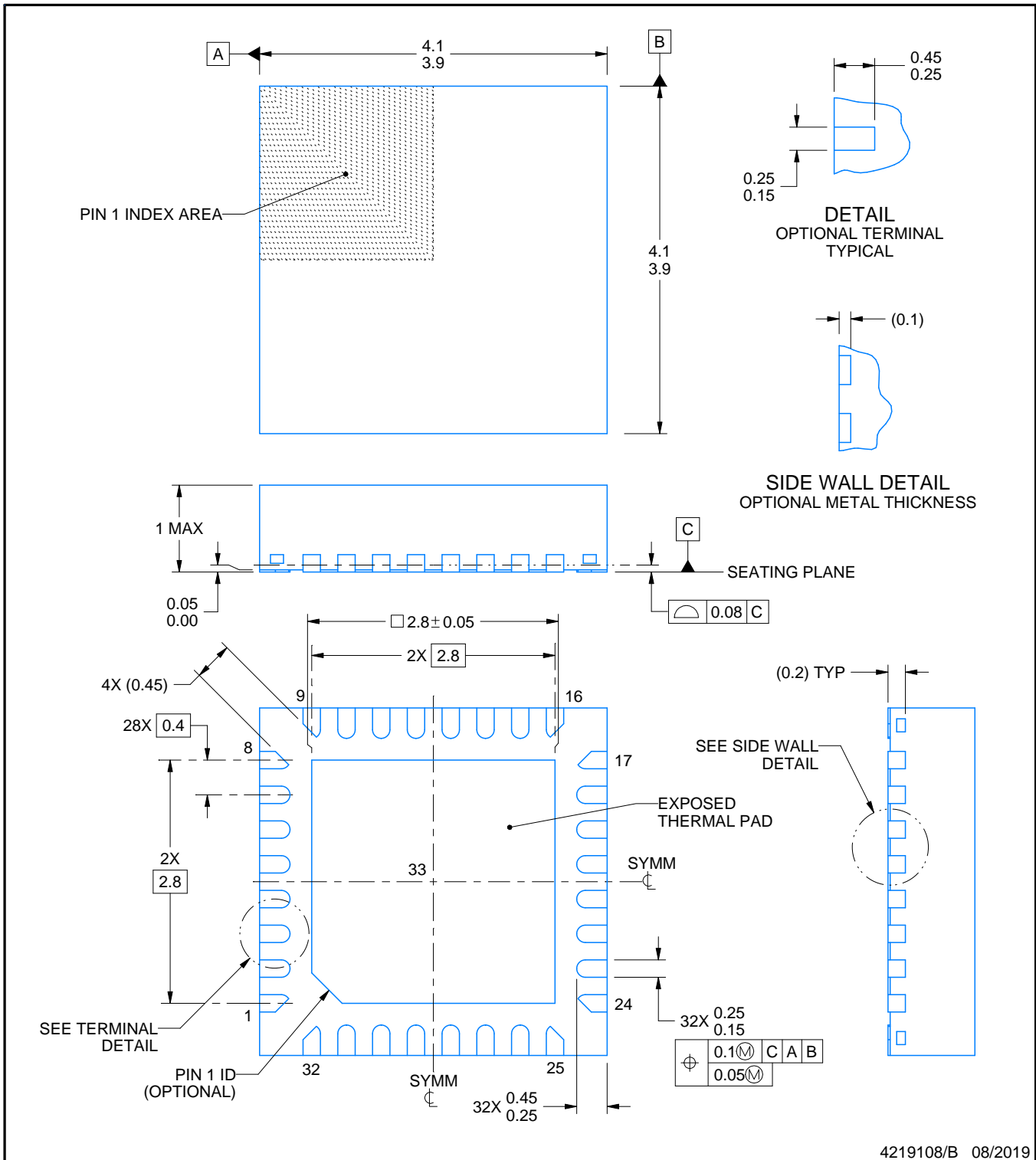

NOTES:

1. All linear dimensions are in millimeters. Any dimensions in parenthesis are for reference only. Dimensioning and tolerancing per ASME Y14.5M.
2. This drawing is subject to change without notice.
3. The package thermal pad must be soldered to the printed circuit board for thermal and mechanical performance.

EXAMPLE BOARD LAYOUT

RSM0032B

VQFN - 1 mm max height

PLASTIC QUAD FLATPACK - NO LEAD

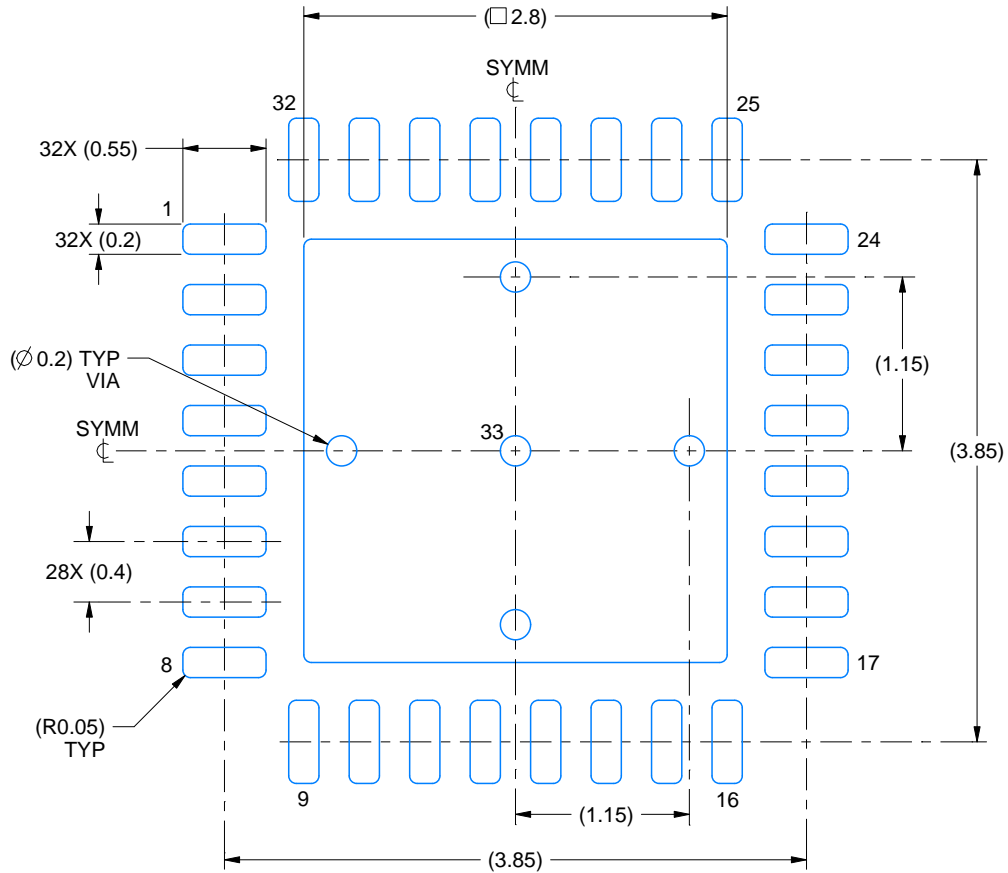

LAND PATTERN EXAMPLE
EXPOSED METAL SHOWN
SCALE:20X

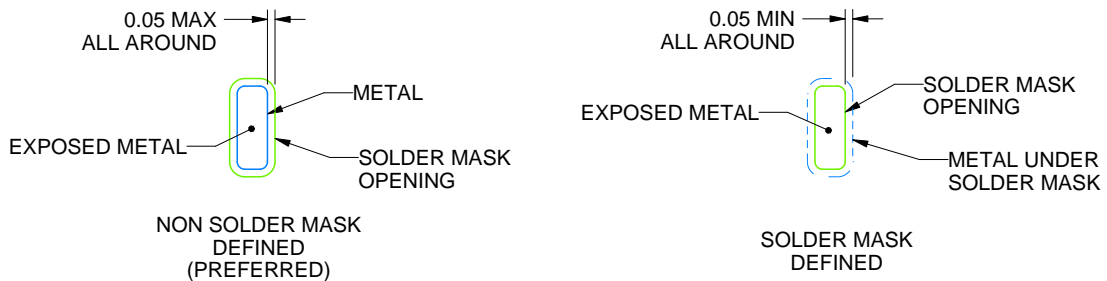

SOLDER MASK DETAILS

4219108/B 08/2019

NOTES: (continued)

- This package is designed to be soldered to a thermal pad on the board. For more information, see Texas Instruments literature number SLUA271 (www.ti.com/lit/slue271).
- Vias are optional depending on application, refer to device data sheet. If any vias are implemented, refer to their locations shown on this view. It is recommended that vias under paste be filled, plugged or tented.

EXAMPLE STENCIL DESIGN

RSM0032B

VQFN - 1 mm max height

PLASTIC QUAD FLATPACK - NO LEAD

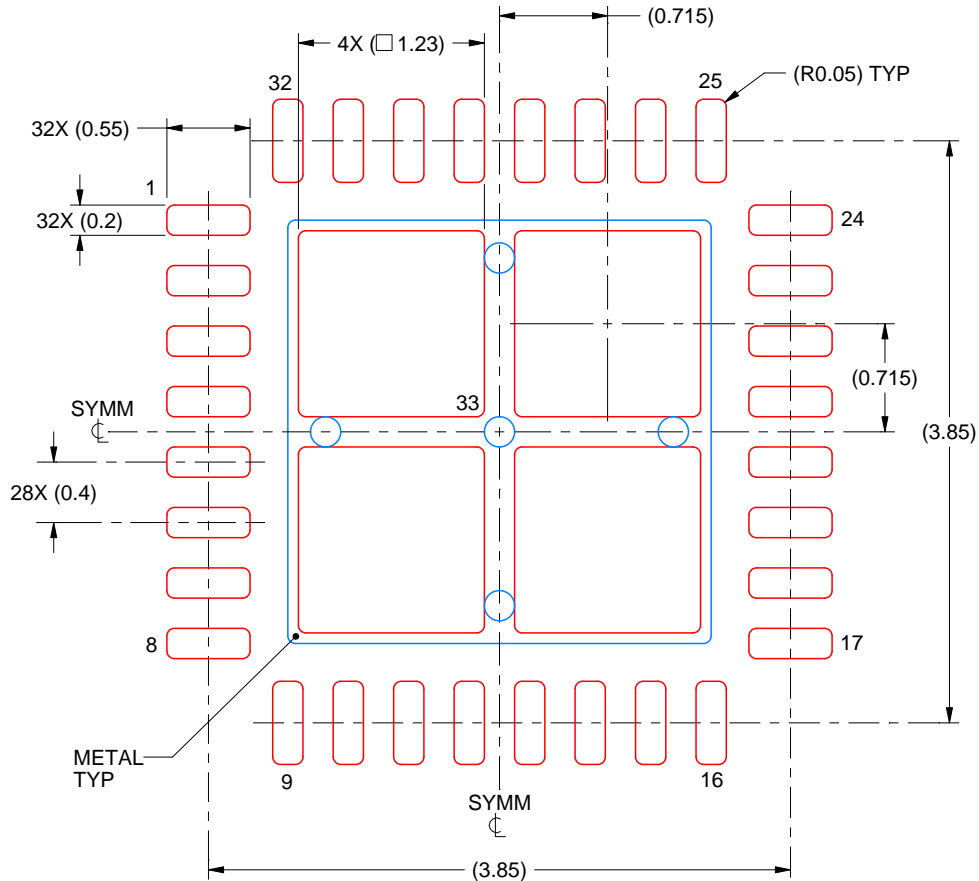

SOLDER PASTE EXAMPLE
BASED ON 0.1 mm THICK STENCIL

EXPOSED PAD 33:
77% PRINTED SOLDER COVERAGE BY AREA UNDER PACKAGE
SCALE:20X

4219108/B 08/2019

NOTES: (continued)

6. Laser cutting apertures with trapezoidal walls and rounded corners may offer better paste release. IPC-7525 may have alternate design recommendations.

IMPORTANT NOTICE AND DISCLAIMER

TI PROVIDES TECHNICAL AND RELIABILITY DATA (INCLUDING DATASHEETS), DESIGN RESOURCES (INCLUDING REFERENCE DESIGNS), APPLICATION OR OTHER DESIGN ADVICE, WEB TOOLS, SAFETY INFORMATION, AND OTHER RESOURCES "AS IS" AND WITH ALL FAULTS, AND DISCLAIMS ALL WARRANTIES, EXPRESS AND IMPLIED, INCLUDING WITHOUT LIMITATION ANY IMPLIED WARRANTIES OF MERCHANTABILITY, FITNESS FOR A PARTICULAR PURPOSE OR NON-INFRINGEMENT OF THIRD PARTY INTELLECTUAL PROPERTY RIGHTS.

These resources are intended for skilled developers designing with TI products. You are solely responsible for (1) selecting the appropriate TI products for your application, (2) designing, validating and testing your application, and (3) ensuring your application meets applicable standards, and any other safety, security, or other requirements. These resources are subject to change without notice. TI grants you permission to use these resources only for development of an application that uses the TI products described in the resource. Other reproduction and display of these resources is prohibited. No license is granted to any other TI intellectual property right or to any third party intellectual property right. TI disclaims responsibility for, and you will fully indemnify TI and its representatives against, any claims, damages, costs, losses, and liabilities arising out of your use of these resources.

TI's products are provided subject to TI's Terms of Sale (<https://www.ti.com/legal/termsofsale.html>) or other applicable terms available either on [ti.com](https://www.ti.com) or provided in conjunction with such TI products. TI's provision of these resources does not expand or otherwise alter TI's applicable warranties or warranty disclaimers for TI products.

Mailing Address: Texas Instruments, Post Office Box 655303, Dallas, Texas 75265
Copyright © 2021, Texas Instruments Incorporated

Looking for pricing, stock, or lifecycle information?

Click below to explore more details on WIN SOURCE:

- ⊖ [View ZL50050GAG2 on WIN SOURCE](#)
- ⊖ [Microchip Technology](#) Information

Optimize Your Supply Chain with WIN SOURCE Solutions

- ✓ Global Sourcing Solution
- ✓ Obsolete Management
- ✓ Cost Control Management
- ✓ Shortage Management
- ✓ Alternative Solution
- ✓ Excess Inventory Management