



**THE DATASHEET OF  
NCP383LMUAJAATXG**



# NCP383

## Adjustable Current-Limiting Power-Distribution Switches

The NCP383 is a single input dual outputs power-distribution switch designed for applications where heavy capacitive loads and short-circuits are likely to be encountered, incorporating two very low  $R_{DS(on)}$ , N-channel MOSFETs in a single package. Each channel of the device limits the output current to a desired level by switching into a constant-current mode when the output load exceeds the current-limit threshold or a short circuit is present. The current-limit threshold is externally fixed by a pull down resistor placed between  $I_{lim}$  and GND. The power-switches rise and fall times are controlled to minimize current ringing during turn on/off.

An internal reverse-voltage detection comparator disables the power-switch if the output voltage is higher than the input voltage to protect devices on the input side of the switches.

The /FLAGx logic output asserts low during over-current, reverse-voltage or over temperature conditions. The switch is controlled by a logic enable input active low.

### Features

- 2.7 V – 5.5 V Operating Range
- Current limit: Adjustable up to 2.8 A
- $\pm 7.5\%$  Current Limit Accuracy at 2.8 A
- Very fast Over-Current Detection Response: 2  $\mu$ s (typ)
- 1  $\mu$ A Maximum Standby Supply Current
- Under Voltage Lock-out (UVLO)
- Soft-Start Prevents Inrush Current
- Thermal Protection
- Soft Turn-off
- Reverse Voltage Protection
- Enable Active Low
- $\mu$ DFN 3x3 mm
- Compliance to IEC61000-4-2 (Level 4)  
8.0 kV (Contact) – 15 kV (Air)
- UL Listed – File E343275
- CB – IEC60950-ED2 Certified
- CB – IEC60950-ED2-AM1 Certified
- This is a Pb-Free Device

### Typical Applications

- Laptops
- USB Ports/Hubs
- TVs



ON Semiconductor®

<http://onsemi.com>



UDFN10  
CASE 517CC

### MARKING DIAGRAM

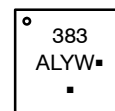

- A = Assembly Location
- L = Wafer Lot
- Y = Year
- W = Work Week
- = Pb-Free Package

(\*Note: Microdot may be in either location)

### PIN CONNECTIONS

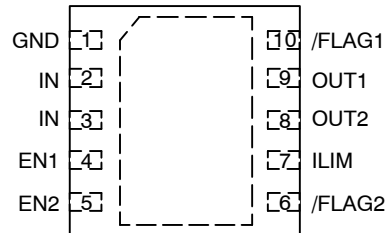

(Top View)

Exposed pad must be soldered to PCB Ground plane.

### ORDERING INFORMATION

See detailed ordering and shipping information in the package dimensions section on page 9 of this data sheet.

# NCP383

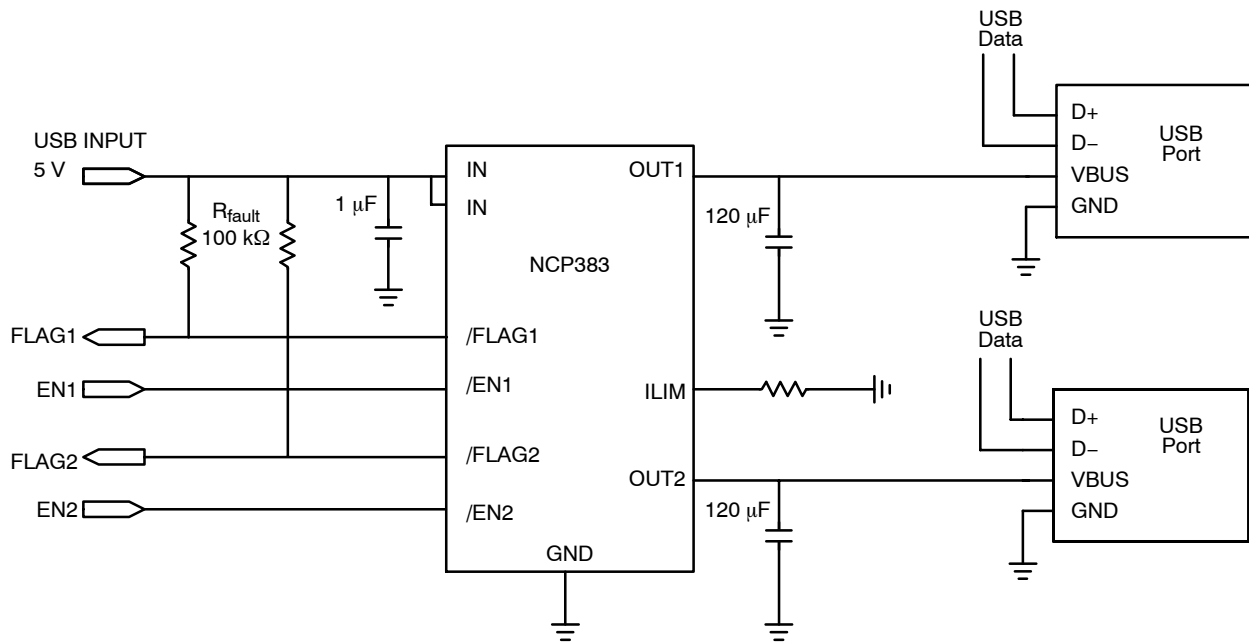

Figure 1. Typical Application Circuit: NCP383xMUAJxx

Adjustable Current limit on Channel 1 and Channel 2

## PIN FUNCTION DESCRIPTION

Pin Name	Number	Type	Description
GND	1	P	Ground connection.
IN	2, 3	P	Power-switch input voltage; connect a 1 $\mu$ F or greater ceramic capacitor from IN to GND as close as possible to the IC. Both IN pins must be hardwired together on the PCB.
/EN1	4	I	Enable 1 input, logic low turns on power switch 1 – If channel 1 is not used, do not leave this pin unconnected. Pull it to $V_{IN}$
/EN2	5	I	Enable 2 input, logic low turns on power switch 2. If channel 2 is not used, do not leave this pin unconnected. Pull it to $V_{IN}$
/FLAG2	6	O	Active-low open-drain output 2, asserted during overcurrent, overtemperature, or reverse-voltage conditions. Connect a 10k $\Omega$ or greater resistor pull-up, otherwise leave unconnected.
ILIM	7	O	External resistor used to set current-limit threshold; recommended $20k\Omega < R_{ILIM} < 120k\Omega$ .
OUT2	8	O	Power-switch output2; connect a 1 $\mu$ F ceramic capacitor from OUT2 to GND as close as possible to the IC is recommended. A 120 $\mu$ F or greater ceramic capacitor from OUT2 to GND must be connected if the USB requirement is not met.
OUT1	9	O	Power-switch output1; connect a 1 $\mu$ F ceramic capacitor from OUT1 to GND as close as possible to the IC is recommended. A 120 $\mu$ F or greater ceramic capacitor from OUT1 to GND must be connected if the USB requirement is not met.
/FLAG1	10	O	Active-low open-drain output 1, asserted during overcurrent, overtemperature, or reverse-voltage conditions. Connect a 10 k $\Omega$ or greater resistor pull-up, otherwise leave unconnected.
PAD	11	Therm	Exposed Thermal Pad: Must be soldered to PCB Ground plane

# NCP383

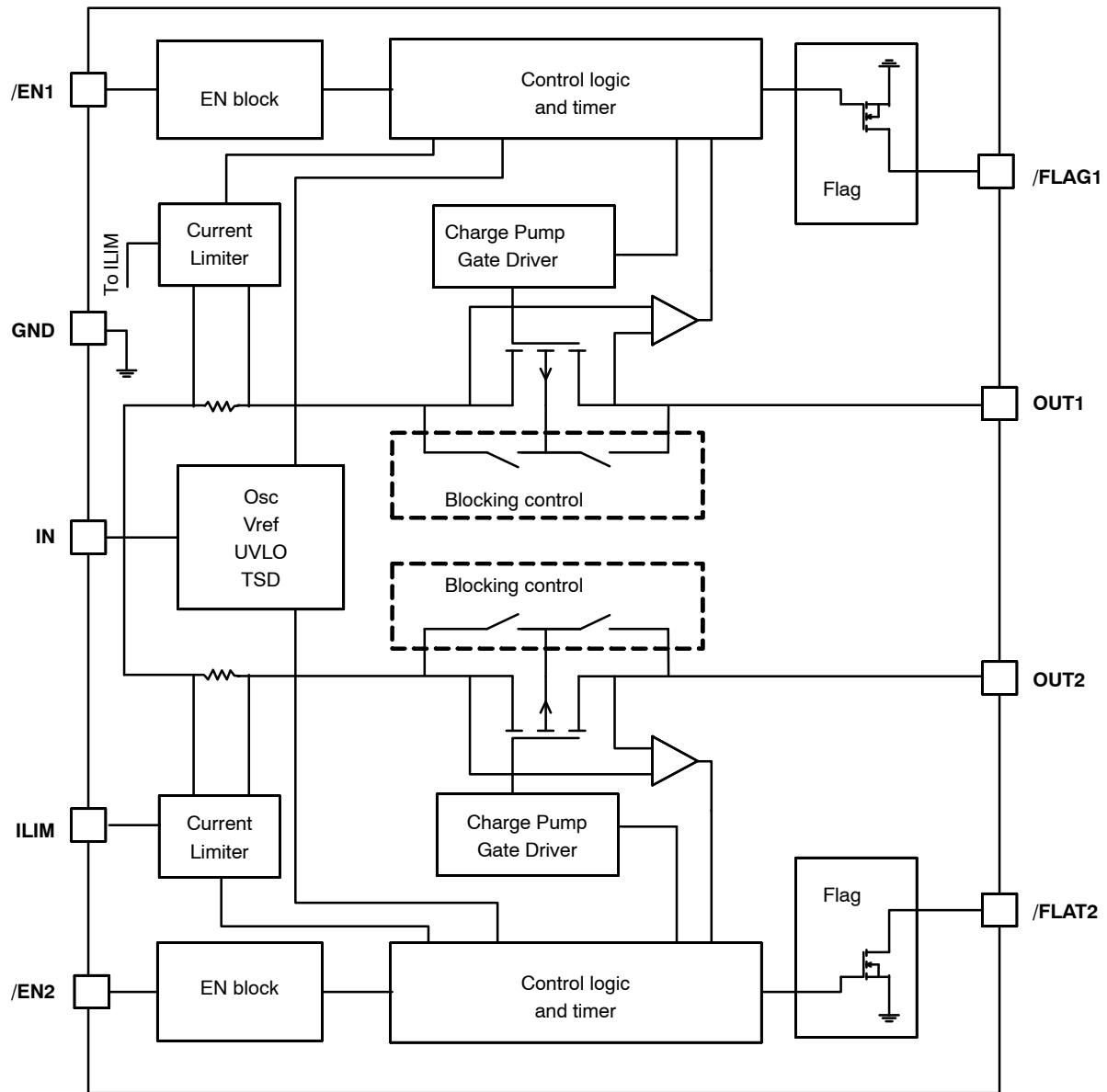

Figure 2. Block Diagram

# NCP383

## MAXIMUM RATINGS

Rating	Symbol	Value	Unit
From IN to OUT1, From IN to OUT2 Supply Voltage (Note 1)	$V_{IN}, V_{OUT1}, V_{OUT2}$	-7.0 to +7.0	V
IN, OUT1, OUT2, /EN1, /EN2, /FLAG1, /FLAG2, ILIM Pins: In/Output (Note 1)	$V_{IN}, V_{OUT1}, V_{OUT2}, V_{EN1}, V_{EN2}, V_{FLAG1}, V_{FLAG2}, V_{ILIM}$	-0.3 to +7.0	V
/FLAG1, /FLAG2 Sink Current	$I_{SINK}$	2	mA
ESD Withstand Voltage (IEC 61000-4-2) (output only, when bypassed with 1.0 $\mu$ F capacitor minimum)	ESD IEC	15 Air, 8 contact	kV
Human Body Model (HBM) ESD Rating are (Note 2)	ESD HBM	2000	V
Machine Model (MM) ESD Rating are (Note 2)	ESD MM	200	V
Latch-up protection (All Pins) (Note 3)	LU	100	mA
Maximum Junction Temperature (Note 4)	$T_J$	-40 to + TSD	$^{\circ}$ C
Storage Temperature Range	$T_{STG}$	-40 to + 150	$^{\circ}$ C
Moisture Sensitivity (Note 5)	MSL	Level 1	

Stresses exceeding Maximum Ratings may damage the device. Maximum Ratings are stress ratings only. Functional operation above the Recommended Operating Conditions is not implied. Extended exposure to stresses above the Recommended Operating Conditions may affect device reliability.

1. According to JEDEC standard JESD22-A108
2. This device series contains ESD protection and passes the following tests:  
Human Body Model (HBM)  $\pm 2.0$  kV per JEDEC standard: JESD22-A114 for all pins.  
Machine Model (MM)  $\pm 200$  V per JEDEC standard: JESD22-A115 for all pins.
3. Latch up Current Maximum Rating: +100 mA per JEDEC standard: JESD78 class II.
4. A thermal shutdown protection avoids irreversible damage on the device due to power dissipation
5. Moisture Sensitivity Level (MSL): 1 per IPC/JEDEC standard: J-STD-020

## OPERATING CONDITIONS

Symbol	Parameter	Conditions	Min	Typ	Max	Unit
$V_{IN}$	Operational Power Supply		2.7		5.5	V
$V_{ENX}$	Enable Voltage		0		5.5	
$T_A$	Ambient Temperature Range		-40	25	+85	$^{\circ}$ C
$I_{SINK}$	/FLAG sink current				1	mA
$C_{IN}$	Decoupling input capacitor		1			$\mu$ F
$C_{OUTX}$	Decoupling output capacitor	USB port per Hub	120			$\mu$ F
$R_{\theta JA}$	Thermal Resistance Junction to Air	DFN-10-12 package (Notes 6 and 7)		85		$^{\circ}$ C/W
$T_J$	Junction Temperature Range		-40	25	+125	$^{\circ}$ C
$I_{OUTX}$	Recommended Maximum DC current	Per Channel			2.5	A
$P_D$	Power Dissipation Rating (Note 8)	$T_A \leq 25^{\circ}$ C	DFN-10 package	850		mW
		$T_A = 85^{\circ}$ C	DFN-10 package	428		

6. Moisture Sensitivity Level (MSL): 1 per IPC/JEDEC standard: J-STD-020
7. The  $R_{\theta JA}$  is dependent of the PCB heat dissipation. Announced thermal resistance is the unless PCB dissipation and can be improve with final PCB layout.
8. The maximum power dissipation ( $P_D$ ) is given by the following formula:

$$P_D = \frac{T_{JMAX} - T_A}{R_{\theta JA}}$$

# NCP383

**ELECTRICAL CHARACTERISTICS** Min & Max Limits apply for  $T_A$  between  $-40^{\circ}\text{C}$  to  $+85^{\circ}\text{C}$  and  $T_J$  up to  $+125^{\circ}\text{C}$  for  $V_{IN}$  between 2.5 V to 5.5 V (Unless otherwise noted). Typical values are referenced to  $T_A = +25^{\circ}\text{C}$  and  $V_{IN} = 5\text{ V}$ .

Symbol	Parameter	Conditions	Conditions	Min	Typ	Max	Unit
--------	-----------	------------	------------	-----	-----	-----	------

### POWER SWITCH

$R_{DS(on)}$	Static drain–source on–state resistance, per channel	$T_J = 25^{\circ}\text{C}$			45	70	m $\Omega$
		$-40^{\circ}\text{C} < T_J < 125^{\circ}\text{C}$				95	
$T_R$	Output rise time	$V_{IN} = 5\text{ V}$	$C_{LOAD} = 1\mu\text{F}$ , $R_{LOAD} = 100\ \Omega$ (Note 9)	1.5	2.5	4	ms
$T_F$	Output fall time	$V_{IN} = 5\text{ V}$		0.1		0.5	

### Logic Pins

$V_{IHEN}$	High–level input voltage			1.2			V
$V_{ILEN}$	Low–level input voltage					0.4	V
$I_{ENx}$	Input current	$V_{ENx} = 0\text{ V}$ , $V_{/ENx} = 5\text{ V}$		-0.5		0.5	$\mu\text{A}$
$T_{ON}$	Turn on time	$C_{LOAD} = 1\mu\text{F}$ , $R_{LOAD} = 100\ \Omega$ (Note 9)		1	-	9	ms
$T_{OFF}$	Turn off time			1		3	ms

### CURRENT LIMIT

$I_{OCP}$	Current–limit threshold (Maximum DC output current $I_{OUTX}$ delivered to load)	$I_{limx} = 90\text{k}$ (Note 10)		0.5	0.6	0.7	A
		$I_{limx} = 56\text{k}$		0.9	1	1.1	
		$I_{limx} = 20\text{k}$ (Note 10)		2.58	2.8	3.01	
$T_{DET}$	Response time to short circuit	$V_{IN} = 5\text{ V}$ (Note 10)			2		$\mu\text{s}$
$T_{REG}$	Regulation time			1	2	3	ms
$T_{OCP}$	Over current protection time			19	24	29	ms

### UNDERVOLTAGE LOCKOUT

$V_{UVLO}$	IN pin low–level input voltage	$V_{IN}$ rising		-	2.45	2.5	V
$V_{HYST}$	IN pin hysteresis	$T_J = 25^{\circ}\text{C}$		25			mV
$T_{RUVLO}$	Re–arming Time			7	12	15	ms

### SUPPLY CURRENT

$I_{INOFF}$	Low–level output supply current.	$V_{IN} = 5\text{ V}$ , No load on OUTX, Device OFF $V_{ENx} = 0\text{ V}$ or $V_{/ENx} = 5\text{ V}$ – $T_J = 25^{\circ}\text{C}$				1	$\mu\text{A}$
$I_{INON}$	High–level output supply current.	$V_{IN} = 5\text{ V}$ , No load on OUTX Device ON – $R_{ILIM} = 56\text{ k}\Omega$ – $V_{ENx} = 5\text{ V}$				99	$\mu\text{A}$
$I_{REV}$	Reverse leakage current	$V_{OUTX} = 5\text{ V}$ , $V_{IN} = 0\text{ V}$	$T_J = 25^{\circ}\text{C}$			1	$\mu\text{A}$

### /FLAGx PINS

$V_{OL}$	/FLAGX output low voltage	$I_{/FLAGX} = 1\text{ mA}$				400	mV
$I_{LEAK}$	Off–state leakage	$V_{/FLAGX} = 5\text{ V}$				1	$\mu\text{A}$
$T_{FGL}$	/FLAGX deglitch	/FLAGX de–assertion time due to overcurrent		3	5	7	ms
$T_{FOCP}$	/FLAGX deglitch	/FLAGX assertion due to overcurrent		5	7	12	ms
$T_{FREX}$	/FLAGX deglitch	/FLAGX assertion due to reverse–voltage		3	5	7	ms

### REVERSE VOLTAGE PROTECTION

$V_{REV}$	Reverse voltage threshold	$V_{OUT} - V_{IN}$ drop			150		mV
$V_{RHYST}$	Reverse voltage threshold hysteresis	$V_{OUT} - V_{IN}$ drop decrease			30		mV

### THERMAL SHUTDOWN

$T_{SD}$	Thermal shutdown threshold				140		$^{\circ}\text{C}$
$T_{SDOCP}$	Thermal regulation threshold				125		$^{\circ}\text{C}$
$T_{RST}$	Thermal regulation rearming threshold				115		$^{\circ}\text{C}$

9. Parameters are guaranteed for  $C_{LOAD}$  and  $R_{LOAD}$  connected to the OUT pin with respect to the ground.  
10. Guaranteed by design and by characterization

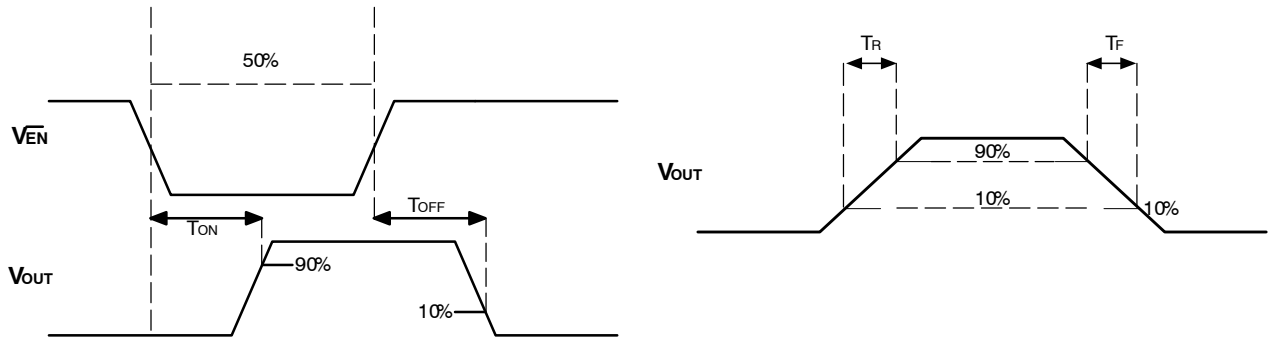

Figure 3. Ton, Toff, Trise, and Tfall

FUNCTIONAL DESCRIPTION

Overview

The NCP383 is a dual high side N channel MOSFET power distribution switches designed to protect the input supply voltage in case of heavy capacitive loads, short circuit or over current. In addition, the high side MOSFETs are turned off during under voltage, thermal shutdown or reverse voltage condition. Thanks to the soft start circuitry, NCP383 is able to limit large current and voltage surges.

Overcurrent Protection

NCP383 switches into a constant current regulation mode when the output current is above the  $I_{OCP}$  threshold. Depending on the load, the output voltage is decreased accordingly.

- In case of hot plug with heavy capacitive load, the output voltage is brought down to the capacitor voltage. The NCP383 will limit the current to the  $I_{OCP}$  threshold value until the charge of the capacitor is completed.

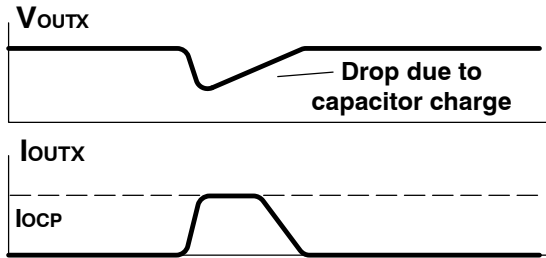

Figure 4. Heavy Capacitive Load

- In case of overload, the current is limited to the  $I_{OCP}$  value and the voltage value is reduced according to the load by the following relation:

$$V_{OUTX} = R_{LOADX} \times I_{OCP} \quad (eq. 1)$$

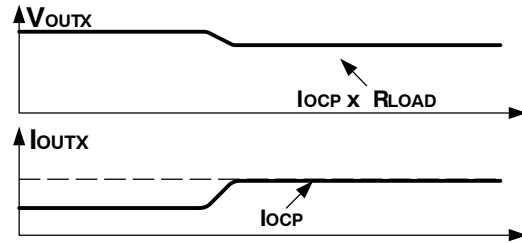

Figure 5. Overload

- In case of short circuit or huge load, the current is limited to the  $I_{OCP}$  value within  $T_{DET}$  time until the short condition is removed. If the output remains shorted or tied to a very low voltage, the junction temperature of the chip exceeds  $T_{SDOCP}$  value and the device enters in thermal shutdown (MOSFET is turned-off).

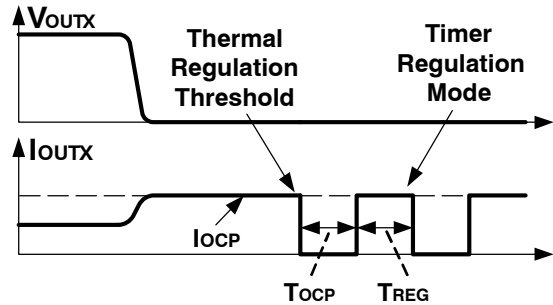

Figure 6. Short Circuit

Then, the device enters in timer regulation mode, described in 2 phases:

- Off-phase: Power MOSFET is off during  $T_{OCP}$  to allow the die temperature to drop.
- On-phase: regulation current mode during  $T_{REG}$ . The current is regulated to the  $I_{OCP}$  level.

The timer regulation mode allows the device to handle high thermal dissipation (in case of short circuit for example) within temperature operating condition.

NCP383 stays in on-phase/off-phase loop until the over current condition is removed or enable pin is toggled.

Remark: other regulation mode can be available for different applications. Please contact our ON Semiconductor representative for availability.

**Adjustable Current-Limit Programming  
NCP383xMUAJxx Version**

The  $R_{LIM}$  resistor connected between ILIM pin and GND determine the current limit threshold according to the electrical characteristic table.

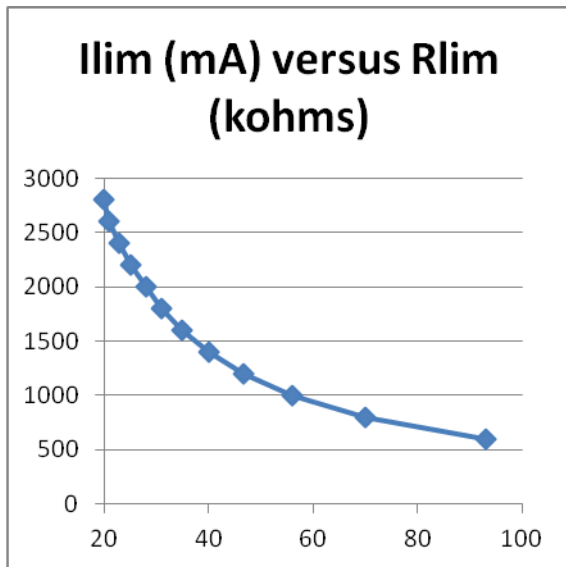

Figure 7. Typical Ilim Curve vs Rlim External Resistor

**/FLAGx Indicators**

The /FLAGx pin are an open-drain MOSFET asserted low during over current, reverse-voltage or over

temperature conditions. When an over current or a reverse voltage fault is detected on the power path, /FLAGx pins are asserted low at the end of the associate deglitch time (see electrical characteristics). Due to this feature, the /FLAGx pins are not tied low during the charge of a heavy capacitive load or a voltage transient on output. Deglitch time is  $T_{FOCP}$  for over current fault and  $T_{FREv}$  for reverse voltage. The /FLAGx pins remain low until the fault is removed. Then, the /FLAG pins go high at the end of  $T_{FGL}$

**Undervoltage Lock-out**

Due to a built-in under voltage lockout (UVLO) circuitry, the output remains disconnected from input until  $V_{IN}$  voltage is above  $V_{UVLO}$ . This circuit has a  $V_{HYST}$  hysteresis witch provides noise immunity to transient condition.

**Thermal Sense**

Thermal shutdown turns off the power MOSFET if the die temperature exceeds  $T_{SD}$ . A Hysteresis of  $T_{HYST}$  prevents the part from turning on until the die temperature cools at  $T_{SD} - T_{HYST}$ .

**Enable Input**

Enable pin must be driven by a logic signal (CMOS or TTL compatible) or connected to the GND or VIN. A logic low turns-on the device. A logic high on /ENX turns off device and reduce the current consumption down to  $I_{INOFF}$ .

Remark: Active high can be available for different applications. Please contact our ON Semiconductor representative for availability.

**Blocking Control**

The blocking control circuitry switches the bulk of the power MOS. When the part is off, the body diode limits the leakage current  $I_{REV}$  from OUTX to IN. In this mode, anode of the body diode is connected to IN pin and cathode is connected to OUTX pin. In operating condition, anode of the body diode is connected to OUTX pin and cathode is connected to IN pin preventing the discharge of the power supply.

APPLICATION INFORMATION

Power Dissipation

The device's junction temperature depends on different contributor factor such as board layout, ambient temperature, device environment, etc... Yet, the main contributor in term of junction temperature is the power dissipation of the power MOSFET. Assuming this, the power dissipation and the junction temperature in normal mode can be calculated with the following equations:

$$P_D = R_{DS(on)} \times \left( (I_{OUT1})^2 + (I_{OUT})^2 \right) \quad (\text{eq. 2})$$

- $P_D$  = Power dissipation (W)
- $R_{DS(on)}$  = Power MOSFET on resistance ( $\Omega$ )
- $I_{OUTx}$  = Output current in channel X (A)
- $T_J = P_D \times R_{\theta JA} + T_A$  (eq. 3)
- $T_J$  = Junction temperature ( $^{\circ}\text{C}$ )
- $R_{\theta JA}$  = Package thermal resistance ( $^{\circ}\text{C}/\text{W}$ )
- $T_A$  = Ambient temperature ( $^{\circ}\text{C}$ )

Power dissipation in regulation mode can be calculated by taking into account the drop  $V_{IN} - V_{OUTX}$  link to the load by the following relation:

$$P_D \times \left( (V_{IN} - R_{LOAD1} \times I_{OCP}) + (V_{IN} - R_{LOAD2} \times I_{OCP}) \right) \times I_{OCP} \quad (\text{eq. 4})$$

- $P_D$  = Power dissipation (W)
- $V_{IN}$  = Input Voltage (V)
- $R_{LOADX}$  = Load Resistance on channel X ( $\Omega$ )
- $I_{OCP}$  = Output regulated current (A)

PCB Recommendations

The NCP383 integrates two up to 3 A rated NMOS FETs, and the PCB design rules must be respected to properly evacuate the heat out of the silicon. The DFN10 PAD1 must be connected to ground plane to increase the heat transfer if necessary. Of course, in any case, this pad must not connect to any other potential. By increasing PCB area, the  $R_{\theta JA}$  of the package can be decreased, allowing higher current.

CIN / COUT1 / COUT2:

- \* AS CLOSE AS POSSIBLE TO NCP383
- \* DIRECTLY CONNECTED TO GND PLANE (LOW IMPEDANCE CONNECTION)
- \* TRY TO AVOID VIAS BETWEEN PIN AND CAPACITOR
- \* IF 120  $\mu\text{F}$  COUT1 and COUT2 ARE LOCATED FAR AWAY FROM NCP383, TRY TO ADD EXTRA LOWER VALUE ( $\sim 0.1 \mu\text{F}$ ) CAPACITOR AS CLOSE AS POSSIBLE TO NCP383

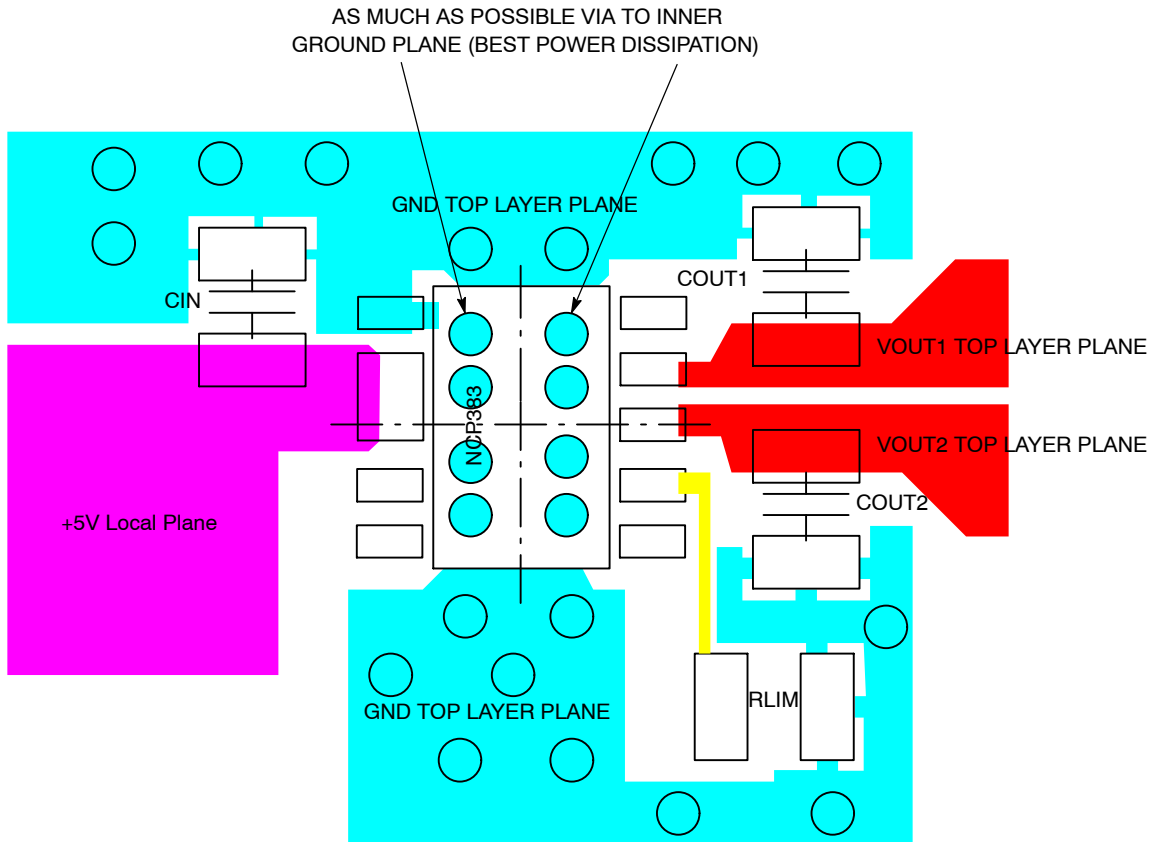

Figure 8. Layout Recommendations

# NCP383

## ORDERING INFORMATION

Device	Package	Shipping†
NCP383LMUAJAATXG	UDFN10 (Pb-Free)	3000 / Tape & Reel

†For information on tape and reel specifications, including part orientation and tape sizes, please refer to our Tape and Reel Packaging Specifications Brochure, BRD8011/D.

## NCP383xMUAJxxTXG

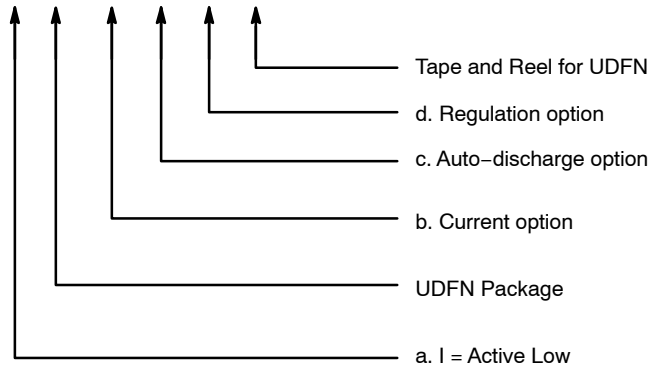

Code	Contents
a	L: active low
b	AJ: adjustable current limit
c	A: No autodischarge output path
d	A: standard regulation (CC + TSD warning + timer)

# MECHANICAL CASE OUTLINE

## PACKAGE DIMENSIONS

ON Semiconductor®



### UDFN10 3x3, 0.5P (Leads 2 & 3 Tied)

#### CASE 517CC

#### ISSUE O

SCALE 2:1

DATE 10 OCT 2011

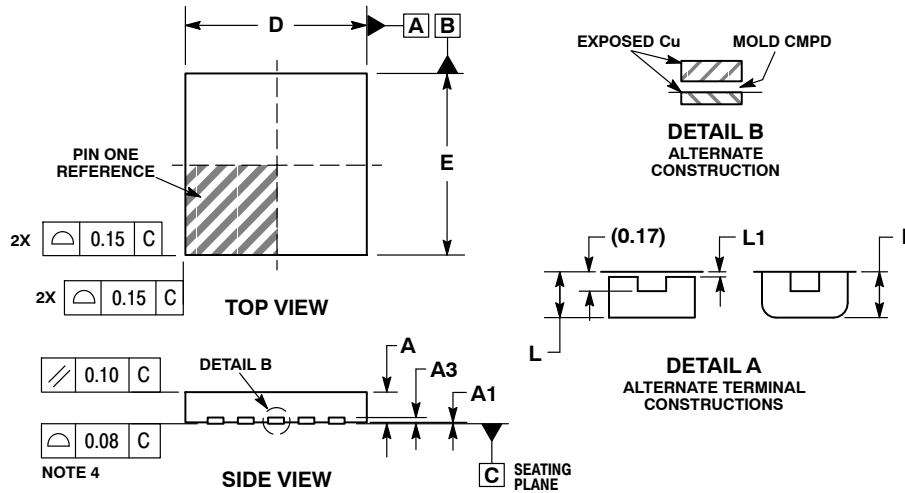

- NOTES:
- DIMENSIONING AND TOLERANCING PER ASME Y14.5M, 1994.
  - CONTROLLING DIMENSION: MILLIMETERS.
  - DIMENSION b APPLIES TO PLATED TERMINAL AND IS MEASURED BETWEEN 0.15 AND 0.30mm FROM THE TERMINAL TIP.
  - COPLANARITY APPLIES TO THE EXPOSED PAD AS WELL AS THE TERMINALS.

DIM	MILLIMETERS	
	MIN	MAX
A	0.45	0.55
A1	0.00	0.05
A3	0.13 REF	
b	0.15	0.25
D	3.00 BSC	
D2	2.39	2.59
E	3.00 BSC	
E2	1.59	1.79
e	0.50 BSC	
L	0.35	0.45
L1	---	0.15

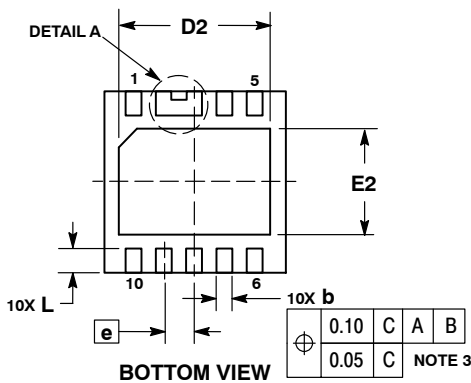

### GENERIC MARKING DIAGRAM\*

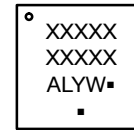

- A = Assembly Location
- L = Wafer Lot
- Y = Year
- W = Work Week
- = Pb-Free Package

(Note: Microdot may be in either location)

\*This information is generic. Please refer to device data sheet for actual part marking. Pb-Free indicator, "G" or microdot "▪", may or may not be present.

\*For additional information on our Pb-Free strategy and soldering details, please download the ON Semiconductor Soldering and Mounting Techniques Reference Manual, SOLDERRM/D.

<b>DOCUMENT NUMBER:</b>	<b>98AON59624E</b>	Electronic versions are uncontrolled except when accessed directly from the Document Repository. Printed versions are uncontrolled except when stamped "CONTROLLED COPY" in red.
<b>DESCRIPTION:</b>	<b>UDFN10 3X3, 0.5P (LEADS 2 &amp; 3 TIED)</b>	<b>PAGE 1 OF 1</b>

ON Semiconductor and ON are trademarks of Semiconductor Components Industries, LLC dba ON Semiconductor or its subsidiaries in the United States and/or other countries. ON Semiconductor reserves the right to make changes without further notice to any products herein. ON Semiconductor makes no warranty, representation or guarantee regarding the suitability of its products for any particular purpose, nor does ON Semiconductor assume any liability arising out of the application or use of any product or circuit, and specifically disclaims any and all liability, including without limitation special, consequential or incidental damages. ON Semiconductor does not convey any license under its patent rights nor the rights of others.

**onsemi**, **Onsemi**, and other names, marks, and brands are registered and/or common law trademarks of Semiconductor Components Industries, LLC dba "**onsemi**" or its affiliates and/or subsidiaries in the United States and/or other countries. **onsemi** owns the rights to a number of patents, trademarks, copyrights, trade secrets, and other intellectual property. A listing of **onsemi**'s product/patent coverage may be accessed at [www.onsemi.com/site/pdf/Patent-Marking.pdf](http://www.onsemi.com/site/pdf/Patent-Marking.pdf). **onsemi** reserves the right to make changes at any time to any products or information herein, without notice. The information herein is provided "as-is" and **onsemi** makes no warranty, representation or guarantee regarding the accuracy of the information, product features, availability, functionality, or suitability of its products for any particular purpose, nor does **onsemi** assume any liability arising out of the application or use of any product or circuit, and specifically disclaims any and all liability, including without limitation special, consequential or incidental damages. Buyer is responsible for its products and applications using **onsemi** products, including compliance with all laws, regulations and safety requirements or standards, regardless of any support or applications information provided by **onsemi**. "Typical" parameters which may be provided in **onsemi** data sheets and/or specifications can and do vary in different applications and actual performance may vary over time. All operating parameters, including "Typicals" must be validated for each customer application by customer's technical experts. **onsemi** does not convey any license under any of its intellectual property rights nor the rights of others. **onsemi** products are not designed, intended, or authorized for use as a critical component in life support systems or any FDA Class 3 medical devices or medical devices with a same or similar classification in a foreign jurisdiction or any devices intended for implantation in the human body. Should Buyer purchase or use **onsemi** products for any such unintended or unauthorized application, Buyer shall indemnify and hold **onsemi** and its officers, employees, subsidiaries, affiliates, and distributors harmless against all claims, costs, damages, and expenses, and reasonable attorney fees arising out of, directly or indirectly, any claim of personal injury or death associated with such unintended or unauthorized use, even if such claim alleges that **onsemi** was negligent regarding the design or manufacture of the part. **onsemi** is an Equal Opportunity/Affirmative Action Employer. This literature is subject to all applicable copyright laws and is not for resale in any manner.

## ADDITIONAL INFORMATION

### TECHNICAL PUBLICATIONS:

Technical Library: [www.onsemi.com/design/resources/technical-documentation](http://www.onsemi.com/design/resources/technical-documentation)  
onsemi Website: [www.onsemi.com](http://www.onsemi.com)

### ONLINE SUPPORT: [www.onsemi.com/support](http://www.onsemi.com/support)

For additional information, please contact your local Sales Representative at [www.onsemi.com/support/sales](http://www.onsemi.com/support/sales)

## Looking for pricing, stock, or lifecycle information?

Click below to explore more details on WIN SOURCE:

- ⊖ [View NCP383LMUAJAATXG on WIN SOURCE](#)
- ⊖ [ON Semiconductor Information](#)

## Optimize Your Supply Chain with WIN SOURCE Solutions

- ✓ Global Sourcing Solution
- ✓ Obsolete Management
- ✓ Cost Control Management
- ✓ Shortage Management
- ✓ Alternative Solution
- ✓ Excess Inventory Management