



**THE DATASHEET OF  
ISL29034IROZ-T7**



ISL29034

Integrated Digital Light Sensor

FN8370  
Rev 2.00  
August 19, 2016

The [ISL29034](#) is an integrated ambient and infrared light-to-digital converter with I<sup>2</sup>C (SMBus compatible) interface. Its advanced self-calibrated photodiode array emulates human eye response with excellent IR rejection. The on-chip ADC is capable of rejecting 50Hz and 60Hz flicker caused by artificial light sources. The Lux range select feature allows users to program the Lux range for optimized counts/Lux.

For ambient light sensing, an internal 16-bit ADC has been designed based upon the charge-balancing technique. The ADC conversion time is nominally 105ms and is user selectable from 11μs to 105ms, depending on oscillator frequency and ADC resolution. In normal operation, typical current consumption is 57μA. In order to further minimize power consumption, two power-down modes have been provided. If polling is chosen over continuous measurement of light, the auto power-down function shuts down the whole chip after each ADC conversion for the measurement. The other power-down mode is controlled by software via the I<sup>2</sup>C interface. The power consumption can be reduced to less than 0.3μA when powered down.

The ISL29034 supports a software brownout condition detection. The device powers up with the brownout bit asserted until the host clears it through the I<sup>2</sup>C interface. Designed to operate on supplies from 2.25V to 3.63V with an I<sup>2</sup>C supply from 1.7V to 3.63V, the ISL29034 is specified for operation across the -40°C to +85°C ambient temperature range.

Features

- Resolution . . . . . 16-bit ADC
- Wide dynamic range<sup>1</sup>: . . . . . 4,200,000
- Integrated noise reduction . . . . . 50/60Hz
- Close to human eye response with excellent IR/UV rejection
- Shutdown modes. . . . .software and automatic
- Supply current (typical) . . . . . 57μA
- Shutdown current (maximum) . . . . . 0.51μA
- I<sup>2</sup>C (SMB compatible) power supply . . . . . 1.7V to 3.63V
- Sensor power supply . . . . . 2.25V to 3.63V
- Operating temperature range. . . . . -40°C to +85°C
- Small form factor package . . . . . 4 Ld 1.5x1.3x0.75 ODFN

Applications

- Mobile devices: smart phone, PDA, GPS
- Computing devices: notebook PC, MacBook, tablets
- Consumer devices: LCD-TV, digital picture frame, digital camera
- Industrial and medical light sensing

Related Literature

- [AN1591](#), "Evaluation Hardware/Software Manual for ALS and Proximity Sensor"

TABLE 1. KEY DIFFERENCES BETWEEN FAMILY OF PARTS

PART NUMBER	ALS SENSING	INTERRUPT PIN	NUMBER OF PINS
ISL29034	Yes	No	4 Ld
ISL29035	Yes	Yes	6 Ld

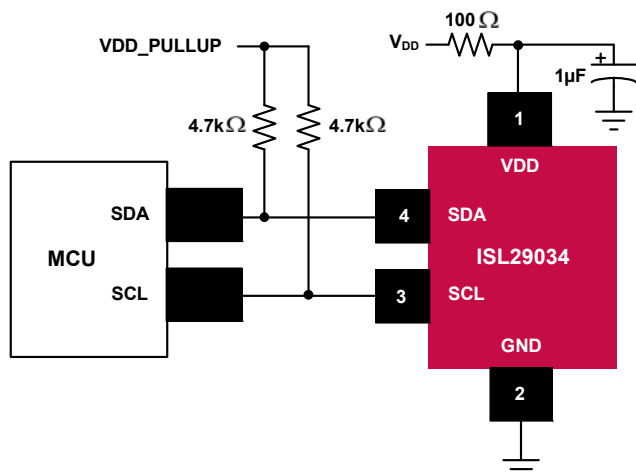

FIGURE 1. ISL29034 TYPICAL APPLICATION DIAGRAM

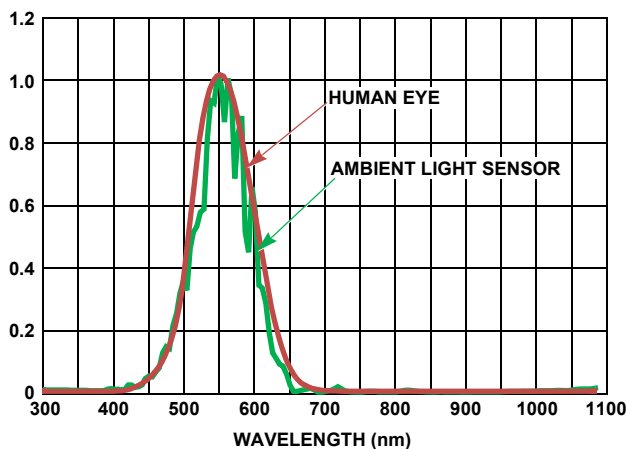

FIGURE 2. NORMALIZED SPECTRAL RESPONSE FOR AMBIENT LIGHT SENSING

## Block Diagram

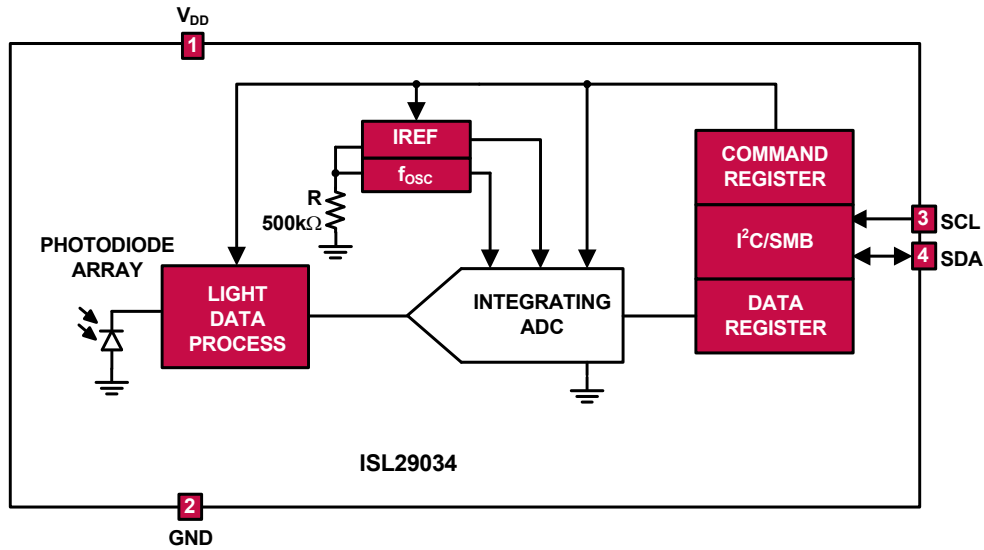
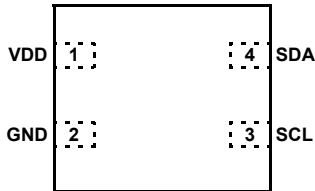

FIGURE 3. BLOCK DIAGRAM

## Pin Configuration

ISL29034  
(4 LD ODFN)  
TOP VIEW



## Pin Descriptions

PIN NUMBER	PIN NAME	DESCRIPTION
1	VDD	Positive supply
2	GND	Ground pin
3	SCL	I <sup>2</sup> C serial clock.
4	SDA	I <sup>2</sup> C serial data.

## Ordering Information

PART NUMBER (Notes 1, 2, 3)	TEMP RANGE (°C)	TAPE AND REEL (UNITS)	PACKAGE (RoHS COMPLIANT)	PKG. DWG. #
ISL29034IROZ-T7	-40 to +85	3k	4 Ld ODFN	L4.1.5x1.3
ISL29034IROZ-EVALZ	Evaluation Board			

### NOTES:

1. Please refer to [TB347](#) for details on reel specifications.
2. These Intersil Pb-free plastic packaged products employ special Pb-free material sets; molding compounds/die attach materials and NiPdAu plate - e4 termination finish, which is RoHS compliant and compatible with both SnPb and Pb-free soldering operations. Intersil Pb-free products are MSL classified at Pb-free peak reflow temperatures that meet or exceed the Pb-free requirements of IPC/JEDEC J STD-020.
3. For Moisture Sensitivity Level (MSL), please see device information page for [ISL29034](#). For more information on MSL please see tech brief [TB477](#).

**Absolute Maximum Ratings**

VDD to GND	+4.0V
I <sup>2</sup> C Bus (SCL, SDA) Pin Voltage	-0.2V to 4.0V
I <sup>2</sup> C Bus (SCL, SDA) Pin Current	<10mA
Input Voltage Slew Rate (Maximum)	0.1V/μs
<b>ESD Ratings</b>	
Human Body Model	3kV

**Thermal Information**

Thermal Resistance (Typical)	$\theta_{JA}$ (°C/W)
4 Ld ODFN Package (Note 4)	287
Maximum Junction Temperature (T <sub>JMAX</sub> )	+90°C
Storage Temperature Range	-40°C to +100°C
Operating Temperature	40°C to +85°C
Pb-Free Reflow Profile	see <a href="#">TB477</a>

**CAUTION:** Do not operate at or near the maximum ratings listed for extended periods of time. Exposure to such conditions may adversely impact product reliability and result in failures not covered by warranty.

**NOTE:**

4.  $\theta_{JA}$  is measured with the component mounted on a high effective thermal conductivity test board in free air. See Tech Brief [TB379](#) for details.

**Electrical Specifications**  $V_{DD} = 3.0V, T_A = +25^\circ C$ , 16-bit ADC operation, unless otherwise specified.

PARAMETER	SYMBOL	TEST CONDITIONS	MIN (Note 7)	TYP	MAX (Note 7)	UNIT
Power Supply Range	$V_{DD}$		2.25		3.63	V
Supply Current	$I_{DD}$			57	85	μA
Supply Current when Powered Down	$I_{DD1}$	Software disabled or auto power-down		0.24	0.51	μA
Supply Voltage Range for I <sup>2</sup> C Interface	$V_{I2C}$		1.70		3.63	V
ADC Integration/Conversion Time	$t_{int}$	16-bit ADC data		105		ms
I <sup>2</sup> C Clock Rate Range	$F_{I2C}$			400		kHz
Count Output When Dark	DATA_0	E = 0 Lux, Range 0 (1k Lux)		1	5	Counts
Full-Scale ADC Code	DATA_F				65535	Counts
Part-to-Part Variation (3σ population)	%/Value	E = 300 Lux, cold white LED Range 0 (1k Lux)		±5		%
Light Count Output with LSB of 0.015 Lux/Count	ADC <sub>R0</sub>	E = 300 Lux, fluorescent light (Note 5), ALS Range 0 (1k Lux)	15000	20473	25000	Counts
Light Count Output with LSB of 0.06 Lux/Count	ADC <sub>R1</sub>	E = 300 Lux, fluorescent light (Note 5), ALS Range 1 (4k Lux)		5100		Counts
Light Count Output with LSB of 0.24 Lux/Count	ADC <sub>R2</sub>	E = 300 Lux, fluorescent light (Note 5), ALS Range 2 (16k Lux)		1400		Counts
Light Count Output with LSB of 0.96 Lux/Count	ADC <sub>R3</sub>	E = 300 Lux, fluorescent light (Note 5), ALS Range 3 (64k Lux)		366		Counts
Infrared Count Output (Note 6)	ADC_IR <sub>R0</sub>	Range 0 (1k Lux)	1402	1997	2598	Counts
Infrared Count Output (Note 6)	ADC_IR <sub>R1</sub>	Range 1 (4k Lux)		481		Counts
Infrared Count Output (Note 6)	ADC_IR <sub>R2</sub>	Range 2 (16k Lux)		148		Counts
Infrared Count Output (Note 6)	ADC_IR <sub>R3</sub>	Range 3 (64k Lux)		42		Counts
SDA Current Sinking Capability	$I_{SDA}$		4	5		mA

**NOTES:**

- 550nm green LED is used in production test. The 550nm LED irradiance is calibrated to produce the same DATA count against an illuminance level of 300 Lux fluorescent light.
- 850 nm IR LED is used in production test.
- Compliance to datasheet limits is assured by one or more methods: production test, characterization and/or design.

**I<sup>2</sup>C Interface Specifications** $V_{DD} = 3.0V$ ,  $T_A = +25^\circ C$ , 16-bit ADC operation, unless otherwise specified.

PARAMETER	SYMBOL	TEST CONDITIONS	MIN (Note 7)	TYP	MAX (Note 7)	UNIT
SDA and SCL Input Buffer LOW Voltage	$V_{IL}$				0.55	V
SDA and SCL Input Buffer HIGH Voltage	$V_{IH}$		1.25			V
SDA and SCL Input Buffer Hysteresis	$V_{Hys}$ (Note 8)			$0.05 \times V_{DD}$		V
SDA Output Buffer LOW Voltage (open-drain), Sinking 4mA	$V_{OL}$ (Note 8)		0	0.06	0.40	V
SDA and SCL Pin Capacitance	$C_{PIN}$ (Note 8)	$T_A = +25^\circ C$ , $f = 1MHz$ , $V_{DD} = 5V$ , $V_{IN} = 0V$ , $V_{OUT} = 0V$			10	pF
SCL Frequency	$f_{SCL}$				400	kHz
Pulse Width Suppression Time at SDA and SCL Inputs	$t_{IN}$	Any pulse narrower than the maximum specification is suppressed			50	ns
SCL Falling Edge to SDA Output Data Valid	$t_{AA}$				900	ns
Time the Bus Must be Free Before the Start of a New Transmission	$t_{BUF}$		1300			ns
Clock LOW Time	$t_{LOW}$		1300			ns
Clock HIGH Time	$t_{HIGH}$		600			ns
START Condition Set-Up Time	$t_{SU:STA}$		600			ns
START Condition Hold Time	$t_{HD:STA}$		600			ns
Input Data Set-Up Time	$t_{SU:DAT}$		100			ns
Input Data Hold Time	$t_{HD:DAT}$		30			ns
STOP Condition Set-Up Time	$t_{SU:STO}$		600			ns
STOP Condition Hold Time	$t_{HD:STO}$		600			ns
Output Data Hold Time	$t_{DH}$		0			ns
SDA and SCL Rise Time	$t_R$ (Note 8)		$20 + 0.1 \times C_b$			ns
SDA and SCL Fall Time	$t_F$ (Note 8)		$20 + 0.1 \times C_b$			ns
Capacitive Loading of SDA or SCL	$C_b$ (Note 10)	Total on-chip and off-chip			400	pF
SDA and SCL Bus Pull-Up Resistor Off-chip	$R_{PU}$ (Note 8)	Maximum is determined by $t_R$ and $t_F$ For $C_b = 400pF$ , maximum is about $2k\Omega \sim 2.5k\Omega$ For $C_b = 40pF$ , maximum is about $15k\Omega \sim 20k\Omega$	1			k $\Omega$

## NOTES:

8. Limits should be considered typical and are not production tested.
9. These are I<sup>2</sup>C specific parameters and are not tested, however, they are used to set conditions for testing devices to validate specification.
10.  $C_b$  is the capacitance of the bus in pF.

## SDA vs SCL Timing

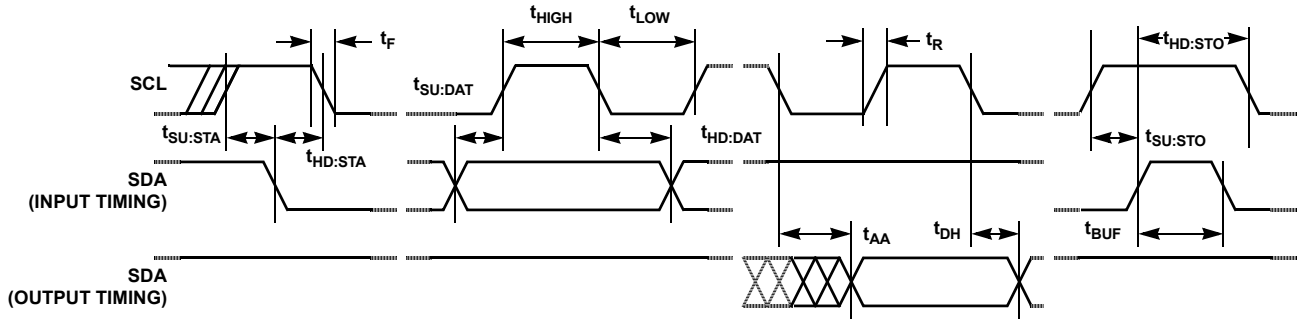

FIGURE 4. I<sup>2</sup>C BUS TIMING

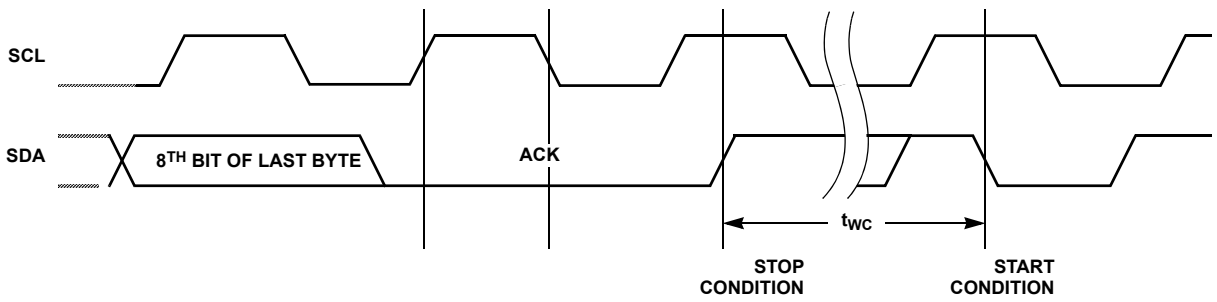

FIGURE 5. I<sup>2</sup>C WRITE CYCLE TIMING

## Typical Performance Curves

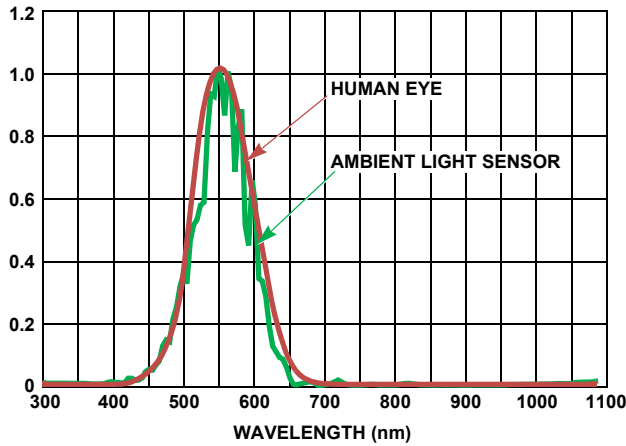

FIGURE 6. NORMALIZED SPECTRAL RESPONSE FOR AMBIENT LIGHT SENSING

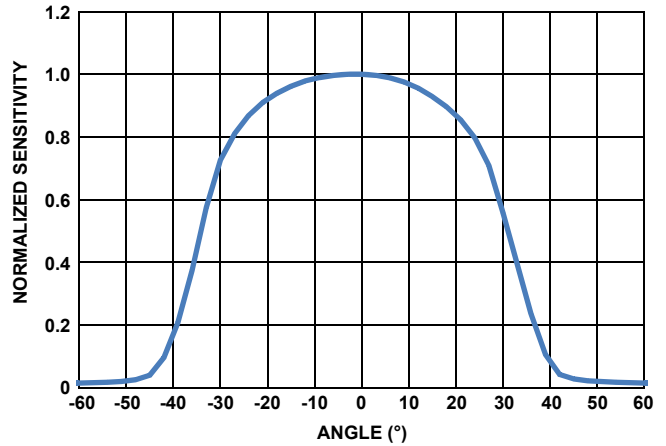

FIGURE 7. NORMALIZED RADIATION PATTERN

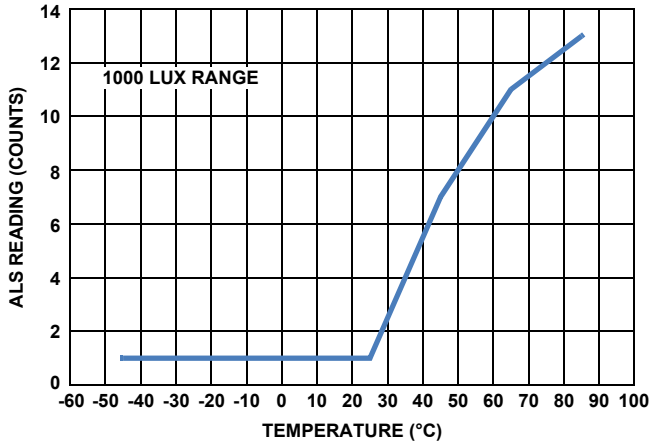

FIGURE 8. TEMPERATURE TEST IN DARK CONDITION

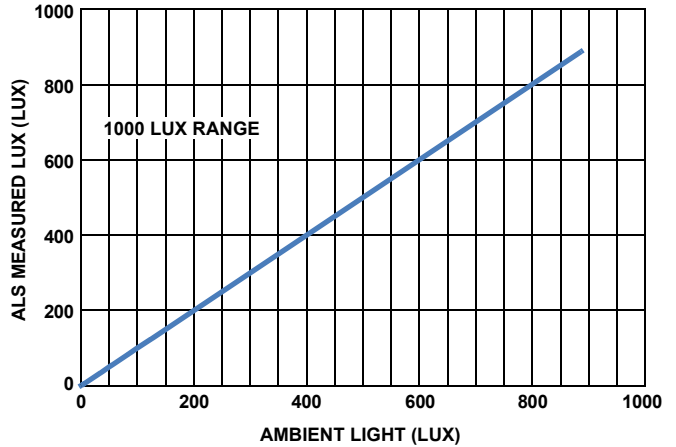

FIGURE 9. ALS TRANSFER FUNCTION

## Principles of Operation

### Photodiodes and ADC

The ISL29034 contains two photodiode arrays, which convert light into current. A typical spectral response for ambient light sensing is shown in [Figure 6 on page 6](#). After light is converted to current during the light signal process, the current output is converted to digital by a built-in 16-bit Analog-to-Digital Converter (ADC). An I<sup>2</sup>C command reads the ambient light intensity in counts.

The converter is a charge-balancing integrating type 16-bit ADC. The chosen method for conversion is best for converting small current signals in the presence of an AC periodic noise. A 105ms integration time, for instance, highly rejects 50Hz and 60Hz power line noise simultaneously.

The integration time of the built-in ADC is determined by the internal oscillator, and the n-bit (n = 4, 8, 12, 16) counter inside the ADC. A good balancing act of integration time and resolution (depending on the application) is required for optimal results.

The ADC has I<sup>2</sup>C programmable range select to dynamically accommodate various lighting conditions. For very dim conditions, the ADC can be configured at its lowest range (Range 0) in the ambient light sensing.

### Low-Power Operation

The ISL29034 initial operation is at the power-down mode after a supply voltage is provided. The data registers contain the default value at 0. When the ISL29034 receives an I<sup>2</sup>C command to do a one-time measurement from an I<sup>2</sup>C master, it will start the ADC conversion with light sensing. It will go to the power-down mode automatically after one conversion is finished and keep the conversion data available for the master to fetch anytime afterwards. The ISL29034 will continuously do ADC conversion with light sensing if it receives an I<sup>2</sup>C command of continuous measurement. It will continuously update the data registers with the latest conversion data. It will go to the power-down mode after it receives the I<sup>2</sup>C command of power-down.

## Ambient Light and IR Sensing

There are four operational modes in ISL29034: Programmable ALS once with auto power-down, programmable IR sensing once with auto power-down, programmable continuous ALS sensing and programmable continuous IR sensing. These four modes can be programmed in series to fulfill the application needs. The detailed program configuration is listed in [“Command-I Register \(Address: 0x00\)” on page 9](#).

When the part is programmed for ambient light sensing, the ambient light with wavelength within the “Ambient Light Sensing” spectral response curve in [Figure 15](#) is converted into current. With ADC, the current is converted to an unsigned n-bit (up to 16 bits) digital output.

When the part is programmed for infrared (IR) sensing, the IR light with wavelength within the “IR Sensing” spectral response curve in [Figure 15](#) is converted into current. With ADC, the current is converted to an unsigned n-bit (up to 16 bits) digital output.

## Serial Interface

The ISL29034 supports the Inter-Integrated Circuit (I<sup>2</sup>C) bus data transmission protocol. The I<sup>2</sup>C bus is a two-wire serial bidirectional interface consisting of SCL (Clock) and SDA (Data). Both the wires are connected to the device supply via pull-up resistors. The I<sup>2</sup>C protocol defines any device that sends data onto the bus as a transmitter and the receiving device as the receiver. The device controlling the transfer is a master and the device being controlled is the slave. The transmitting device pulls down the SDA line to transmit a “0” and releases it to transmit a “1”. The master always initiates the data transfer, only when the bus is not busy, and provides the clock for both transmit and receive operations. The ISL29034 operates as a slave device in all applications. The serial communication over the I<sup>2</sup>C interface is conducted by sending the Most Significant Bit (MSB) of each byte of data first.

### Start Condition

During data transfer, the SDA line must remain stable while the SCL line is HIGH. All I<sup>2</sup>C interface operations must begin with a START condition, which is a HIGH to LOW transition of SDA while SCL is HIGH (refer to [Figure 12 on page 8](#)). The ISL29034 continuously monitors the SDA and SCL lines for the START condition and does not respond to any command until this condition is met (refer to [Figure 12](#)). A START condition is ignored during the power-up sequence.

### Stop Condition

All I<sup>2</sup>C interface operations must be terminated by a STOP condition, which is a LOW to HIGH transition of SDA while SCL is HIGH (refer to [Figure 12](#)). A STOP condition at the end of a read/write operation places the device in its standby mode. If a stop is issued in the middle of a Data byte, or before 1 full Data byte + ACK is sent, then the serial communication of the ISL29034 resets itself without performing the read/write. The contents of the array are not affected.

### Acknowledge

An Acknowledge (ACK) is a software convention used to indicate a successful data transfer. The transmitting device releases the

SDA bus after transmitting 8 bits. During the ninth clock cycle, the receiver pulls the SDA line LOW to acknowledge the reception of the eight bits of data (refer to [Figure 12](#)). The ISL29034 responds with an ACK after recognition of a START condition followed by a valid Identification Byte, and once again, after successful receipt of an Address Byte. The ISL29034 also responds with an ACK after receiving a Data byte of a write operation. The master must respond with an ACK after receiving a Data byte of a read operation.

## Device Addressing

Following a START condition, the master must output a Device Address byte. The 7 MSBs of the Device Address byte are known as the device identifier. The device identifier bits of the ISL29034 are internally hard-wired as “1000100”. The LSB of the Device Address byte is defined as a Read or Write (R/ $\bar{W}$ ) bit. When this R/ $\bar{W}$  bit is a “1”, a read operation is selected and when “0”, a write operation is selected (refer to [Figure 10](#)). The master generates a START condition followed by Device Address byte 1000100x (x as R/ $\bar{W}$ ) and the ISL29034 compares it with the internal device identifier. Upon a correct comparison, the device outputs an acknowledge (LOW) on the SDA line (refer to [Figure 12](#)).

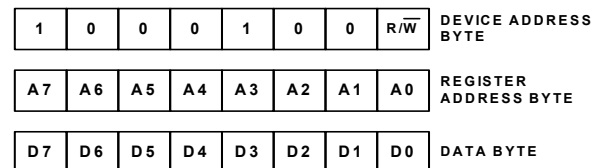

FIGURE 10. DEVICE ADDRESS, REGISTER ADDRESS AND DATA BYTE

## Write Operation

### BYTE WRITE

In a byte write operation, the ISL29034 requires the Device Address byte, Register Address byte, and the Data byte. The master starts the communication with a START condition. Upon receipt of the Device Address byte, Register Address byte and the Data byte, the ISL29034 responds with an Acknowledge (ACK). Following the ISL29034 data acknowledge response, the master terminates the transfer by generating a STOP condition.

The ISL29034 then begins an internal write cycle of the data to the volatile memory. During the internal write cycle, the device inputs are disabled and the SDA line is in a high impedance state, so the device will not respond to any requests from the master (refer to [Figure 11](#)).

### BURST WRITE

The ISL29034 has a burst write operation, which allows the master to write multiple consecutive bytes from a specific address location. It is initiated in the same manner as the byte write operation, but instead of terminating the write cycle after the first Data byte is transferred, the master can write to the whole register array. After the receipt of each byte, the ISL29034 responds with an acknowledge, and the address is internally incremented by one. The address pointer remains at the last address byte written. When the counter reaches the end of the register address list, it “rolls over” and goes back to the first Register Address.

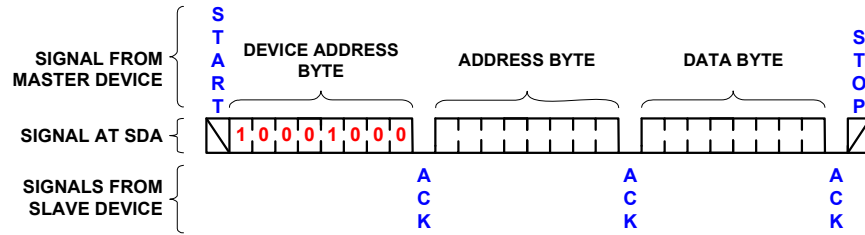

FIGURE 11. BYTE WRITE SEQUENCE

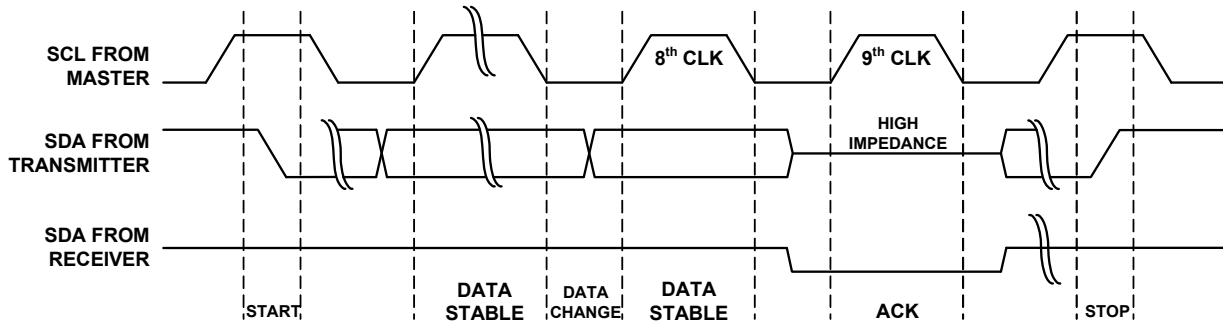

FIGURE 12. START, DATA STABLE, ACKNOWLEDGE AND STOP CONDITION

## Read Operation

The ISL29034 has two basic read operations: Byte read and Burst read.

### BYTE READ

Byte read operations allow the master to access any register location in the ISL29034. The Byte read operation is a two step process. The master issues the START condition, and the Device Address byte with the R/W bit set to "0", receives an acknowledge, then issues the Register Address byte. After acknowledging receipt of the Register Address byte, the master immediately issues another START condition and the Device Address byte with the R/W bit set to "1". This is followed by an acknowledge from the device and then by the 8-bit data word. The master terminates the read operation by not responding with an acknowledge and then issuing a stop condition (refer to [Figure 13](#)).

### BURST READ

Burst read operation is identical to the Byte read operation. After the first Data byte is transmitted, the master now responds with an acknowledge, indicating it requires additional data. The device continues to output data for each acknowledge received. The master terminates the read operation by not responding with an acknowledge but issuing a STOP condition (refer to [Figure 14](#)).

For more information about the I<sup>2</sup>C standard, please consult the Phillips™ I<sup>2</sup>C specification documents.

## Power-On Reset

The Power-On Reset (POR) circuitry protects the internal logic against powering up in the incorrect state. The ISL29034 will power-up into Standby mode after  $V_{DD}$  exceeds the POR trigger level and will power-down into Reset mode when  $V_{DD}$  drops below the POR trigger level. This bidirectional POR feature protects the device against 'brown-out' failure following a temporary loss of power.

The POR is an important feature because it prevents the ISL29034 from starting to operate with insufficient voltage, prior to stabilization of the internal bandgap. The ISL29034 prevents communication to its registers and greatly reduces the likelihood of data corruption on power-up.

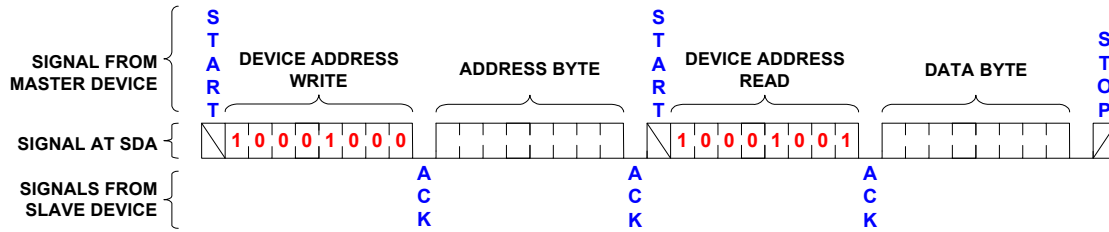

FIGURE 13. BYTE ADDRESS READ SEQUENCE

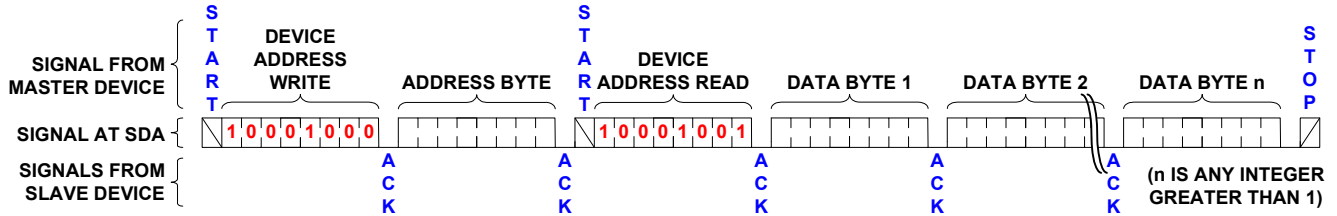

FIGURE 14. BURST READ SEQUENCE

TABLE 2. REGISTER MAP

NAME	REGISTER ADDRESS		REGISTER BITS								DEFAULT	ACCESS
	DEC	HEX	B7	B6	B5	B4	B3	B2	B1	B0		
COMMAND-I	0	0x00	OP2	OP1	OP0	RESERVED					0x00	RW
COMMAND-II	1	0x01	RESERVED				RES1	RES0	RANGE1	RANGE0	0x00	RW
DATA <sub>LSB</sub>	2	0x02	D7	D6	D5	D4	D3	D2	D1	D0	0x00	RO
DATA <sub>MSB</sub>	3	0x03	D15	D14	D13	D12	D11	D10	D9	D8	0x00	RO
ID	15	0x0F	BOUT	RESERVED	1	0	1	RESERVED			1x101xxx	RW

## Register Description

Following are detailed descriptions of the control registers related to the operation of the ISL29034 ambient light sensor device. These registers are accessed by the I<sup>2</sup>C serial interface. For details on the I<sup>2</sup>C interface, refer to “Serial Interface” on page 7.

All the features of the device are controlled by the registers. The ADC data can also be read. The following sections explain the details of each register bit. All RESERVED bits are Intersil used bits ONLY. The value of the reserved bit can change without notice.

### Decimal to Hexadecimal Conversion

To convert decimal value to hexadecimal value, divide the decimal number by 16, and write the remainder on the side as the least significant digit. This process is continued by dividing the quotient by 16 and writing the remainder until the quotient is 0. When performing the division, the remainders, which will represent the hexadecimal equivalent of the decimal number, are written beginning with the least significant digit (right) and each new digit is written to the next most significant digit (the left) of the previous digit. Consider the number 175 decimal.

TABLE 3. DECIMAL TO HEXADECIMAL

DIVISION	QUOTIENT	REMAINDER	HEX NUMBER
175/16	10 = A	15 = F	0xAF

### Command-I Register (Address: 0x00)

TABLE 4. COMMAND-I REGISTER ADDRESS

NAME	ADDR (HEX)	REGISTER BITS								DFLT (HEX)
		B7	B6	B5	B4	B3	B2	B1	B0	
COMMAND-I	0x00	OP2	OP1	OP0	RESERVED					0x00

The Command-I register consists three operation mode bits. The default register value is 0x00 at power-on.

Command-I Register (Address: 0x0 Operation Mode Bits[7:5])

The ISL29034 has different operating modes. These modes are selected by setting B7 to B5 bits on register address 0x00. The device powers up on a disable mode. Table 5 on page 10 lists the possible operating modes.

TABLE 5. OPERATING MODES BITS

B7	B6	B5	OPERATION
0	0	0	Power-down the device (Default)
0	0	1	The device measures ALS only once every integration cycle. This is the lowest operating mode. (Note 11)
0	1	0	IR once
0	1	1	Reserved (Do Not Use)
1	0	0	Reserved (Do Not Use)
1	0	1	Measures ALS continuously
1	1	0	Measures IR continuous
1	1	1	Reserved (Do Not Use)

NOTE:

11. Intersil does not recommend using this mode

## Command-II Register (Address: 0x01)

TABLE 6. COMMAND-II REGISTER BITS

NAME	REG. ADDR (HEX)	REGISTER BITS							DFLT (HEX)
		B7	B6	B5	B4	B3	B2	B1	
COMMAND-II	0x01	RESERVED			RES 1	RES 0	RANGE 1	RANGE 0	0x00

The Command-II register consists of ADC control bits. In this register, there are two range bits and two ADC resolution bits. The default register value is 0x00 at power-on.

### FULL SCALE LUX RANGE [B1:B0]

The full scale Lux range has four different selectable ranges. The range determines the full scale Lux range (1k, 4k, 16k, and 64k). Each range has a maximum allowable Lux value. Table 7 lists the possible values of FSR.

TABLE 7. RANGE REGISTER BITS

RANGE SELECTION	B1	B0	FULL SCALE LUX RANGE (LUX)
0	0	0	1,000
1	0	1	4,000
2	1	0	16,000
3	1	1	64,000

### Integration Time ADC Resolution [B3:B2]

B2 and B3 determine the ADC's resolution and the number of clock cycles per conversion. Changing the number of clock cycles does more than just change the resolution of the device; it also changes the integration time, which is the period the device's Analog-to-Digital (A/D) converter samples the photodiode current signal for a measurement. Table 8 lists the possible ADC resolution. Only 16 bit ADC resolution can reject better 50Hz/60Hz noise flickering light source.

TABLE 8. ADC RESOLUTION DATA WIDTH

B3	B2	NUMBER OF CLOCK CYCLES	n-BIT ADC
0	0	$2^{16} = 65,536$	16
0	1	$2^{12} = 4,096$	12
1	0	$2^8 = 256$	8
1	1	$2^4 = 16$	4

## Integration Time

TABLE 9. INTEGRATION TIME OF n-BIT ADC

n # ADC BITS	INTEGRATION TIME (ms)
4	0.022
8	0.352
12	5.6
16	105

## Data Registers (Addresses: 0x02 and 0x03)

TABLE 10. ADC REGISTER BITS

NAME	Reg. Addr (HEX)	REGISTER BITS								DFLT (HEX)
		B7	B6	B5	B4	B3	B2	B1	B0	
DATA <sub>LSB</sub>	0x02	D7	D6	D5	D4	D3	D2	D1	D0	0x00
DATA <sub>MSB</sub>	0x03	D15	D14	D13	D12	D11	D10	D9	D8	0x00

The ISL29034 has two 8-bit read-only registers to hold the upper and lower byte of the ADC value. The Upper byte is accessed at Address 0x03 and the Lower byte is accessed at Address 0x02. For 16-bit resolution, the data is from D0 to D15; for 12-bit resolution, the data is from D0 to D11; for 8-bit resolution, the data is from D0 to D7 and for 4-bit resolution, the data is from D0 to D3. The registers are refreshed after every conversion cycle. The default register value is 0x00 at power-on.

TABLE 11. ADC DATA REGISTERS

ADDRESS (HEX)	CONTENTS
0x02	D0 is LSB for 4-, 8-, 12- or 16-bit resolution; D3 is MSB for 4-bit resolution; D7 is MSB for 8-bit resolution
0x03	D15 is MSB for 16-bit resolution; D11 is MSB for 12-bit resolution

## ID Register (Address: 0x0F)

TABLE 12. ID REGISTER BITS

NAME	ADDR (HEX)	REGISTER BITS								DFLT
		B7	B6	B5	B4	B3	B2	B1	B0	
ID	0x0F	BOUT	RESERVED	1	0	1	RESERVED	RESERVED	RESERVED	1x101xxx

The ID register has three different types of information.

## RESERVED BITS [B2:B0] AND [B6]

All RESERVED bits on the ISL29034 are Intersil used bits only. Bit0 to Bit2 and Bit6 are RESERVED bits where their value might change without any notification to the user. It is advised when using the identification bits to identify the device in a system, the software should mask the Bit0 to Bit2 and Bit6 to Bit7 to properly identify the device.

## DEVICE ID BITS [B5:B3]

The ISL29034 provides 3 bits to identify the device in a system. These bits are located on register address 0x0F, Bit3 to Bit5. The identification bit value for the ISL29034 is xx101xxx. The device identification bits are read only bits. It is important to notice that Bit7 is a status bit for Brownout Condition (BOUT).

## BROWNOUT STATUS BIT TO BOUT [B7]

Bit7 on register address 0x0F is a status bit for Brownout Condition (BOUT). The default value of this bit is "BOUT = 1" during the initial power-up, which indicates the device may possibly have gone through a brownout condition. Therefore, the status bit should be reset to "BOUT = 0" by an I<sup>2</sup>C write command during the initial configuration of the device.

The default register value is 0xA8 at power-on.

## Applications Information

Figure 15 is a normalized spectral response of various types of light sources for reference.

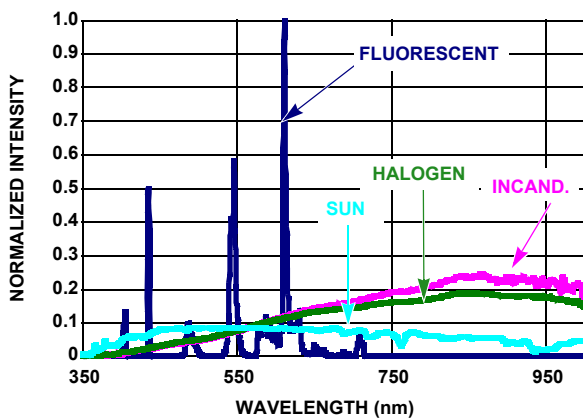

FIGURE 15. NORMALIZED SPECTRAL RESPONSE OF LIGHT SOURCES

## Calculating Lux

The ISL29034's ADC output codes, DATA, are directly proportional to Lux in the ambient light sensing.

$$E_{\text{cal}} = \alpha \times \text{DATA} \quad (\text{EQ. 1})$$

Where  $E_{\text{cal}}$  is the calculated Lux reading. The constant  $\alpha$  is determined by the full-scale range and the ADC's maximum output counts. The constant is independent of the light sources (fluorescent, incandescent and sunlight) because the light sources IR component is removed during the light signal process.

The constant can also be viewed as the sensitivity (the smallest Lux measurement the device can measure).

$$\alpha = \frac{\text{Range}}{\text{Count}_{\text{max}}} \quad (\text{EQ. 2})$$

Where, Range is defined in Table 7 on page 10.  $\text{Count}_{\text{max}}$  is the maximum output counts from the ADC.

The transfer function used for n-bits ADC becomes:

$$E_{\text{cal}} = \frac{\text{Range}}{2^n} \times \text{DATA} \quad (\text{EQ. 3})$$

Where n = 4, 8, 12 or 16. This is the number of ADC bits programmed in the command register.  $2^n$  represents the maximum number of counts possible from the ADC output. Data is the ADC output stored in the data registers (02 hex and 03 hex).

## Enhancing EV Accuracy

The device has on-chip passive optical filter designed to block (reject) most of the incident Infra Red. However, EV measurement may vary under differing IR-content light sources. In order to optimize the measurement variation between differing IR-content light sources, ISL29034 provides IR channel, which is programmed at COMMAND-1 (Reg0x0) to measure the IR level of differing IR-content light sources.

The ISL29034's ADC output codes, DATA, are directly proportional to the IR intensity received in the IR sensing.

$$\text{DATA}_{\text{IR}} = \beta \times E_{\text{IR}} \quad (\text{EQ. 4})$$

Then EV accuracy can be found in Equation 5:

$$\text{EV}_{\text{Accuracy}} = K \times \text{DATA}_{\text{EV}} + \beta \times \text{DATA}_{\text{IR}} \quad (\text{EQ. 5})$$

Here,  $\text{DATA}_{\text{EV}}$  is the received ambient light intensity ADC output codes. K is a resolution of visible portion. Its unit is Lux/count. The typical value of K is 0.82.  $\text{DATA}_{\text{IR}}$  is the received IR intensity. The constant  $\beta$  changes with the spectrum of background IR, such as A, F2 and D65 (Notes 8, 9 and 10). The  $\beta$  also changes with the ADC's range and resolution selections. A typical  $\beta$  for Range1 and Range2 is -11292.86 and Range3 and Range4 is 2137.14 without IR tinted glass.

## Noise Rejection

Electrical AC power worldwide is distributed at either 50Hz or 60Hz. Artificial light sources vary in intensity at the AC power frequencies. The undesired interference frequencies are infused on the electrical signals. This variation is one of the main sources of noise for the light sensors. Integrating type ADC's have excellent noise-rejection characteristics for periodic noise sources whose frequency is an integer multiple of the conversion rate. By setting the sensor's integration time to an integer multiple of periodic noise signal, the performance of an ambient light sensor can be improved greatly in the presence of noise. In order to reject the AC noise, the integration time of the sensor must be adjusted to match the AC noise cycle. For instance, a 60Hz AC unwanted signal's sum from 0ms to  $k \times 16.66\text{ms}$  ( $k = 1, 2, \dots, k_i$ ) is zero. Similarly, setting the device's integration time to be an integer multiple of the periodic noise signal, greatly improves the light sensor output signal in the presence of noise.

## Suggested PCB Footprint

It is important that users check [TB477](#) “Surface Mount Assembly Guidelines for Optical Dual Flat Pack No Lead (ODFN) Package” before starting ODFN product board mounting.

## Board Mounting Considerations

For applications requiring the light measurement, the board mounting location should be reviewed. The device uses an Optical Dual Flat Pack No Lead (ODFN) package, which subjects the die to mild stresses when the printed circuit (PC) board is heated and cooled, which slightly changes the shape. Because of these die stresses, placing the device in areas subject to slight twisting can cause degradation of reference voltage accuracy. It is normally best to place the device near the edge of a board, or on the shortest side, because the axis of bending is most limited in that location.

## Layout Considerations

The ISL29034 is relatively insensitive to layout. Like other I<sup>2</sup>C devices, it is intended to provide excellent performance even in significantly noisy environments. There are only a few considerations that will ensure best performance.

Route the supply and I<sup>2</sup>C traces as far as possible from all sources of noise. Use two power-supply decoupling capacitors, 1μF and 0.1μF, placed close to the device.

## Soldering Considerations

Convection heating is recommended for reflow soldering; direct-infrared heating is not recommended. The plastic ODFN package does not require a custom reflow soldering profile and is qualified to +260 °C. A standard reflow soldering profile with a +260 °C maximum is recommended.

## Temperature Coefficient

The limits stated for Temperature Coefficient (TC) are governed by the method of measurement. The “Box” method is usually used for specifying the temperature coefficient. The overwhelming standard for specifying the temperature drift of a reference is to evaluate the maximum voltage change over the specified temperature range. This yields ppm/°C, and is calculated using [Equation 4](#):

$$TC = \frac{V_{HIGH} - V_{LOW}}{V_{NOMINAL} \times (T_{HIGH} - T_{LOW})} \times 10^6 \quad (EQ. 6)$$

Where:

V<sub>HIGH</sub> is the maximum reference voltage over the temperature range.

V<sub>LOW</sub> is the minimum reference voltage over the temperature range.

V<sub>NOMINAL</sub> is the nominal reference voltage at +25 °C.

T<sub>HIGH</sub> - T<sub>LOW</sub> is the specified temperature range (°C).

## Digital Inputs and Termination

The ISL29034 digital inputs are guaranteed to CMOS levels. The internal register is updated on the rising edge of the clock.

To minimize reflections, proper termination should be implemented. If the lines driving the clock and the digital inputs are 50Ω lines, then 50Ω termination resistors should be placed as close to the sensor inputs as possible, connected to the digital ground plane (if separate grounds are used).

## Typical Circuit

A typical application for the ISL29034 is shown in [Figure 16](#). The ISL29034’s I<sup>2</sup>C address is internally hard-wired as 1000100. The device can be tied onto a system’s I<sup>2</sup>C bus together with other I<sup>2</sup>C compliant devices.

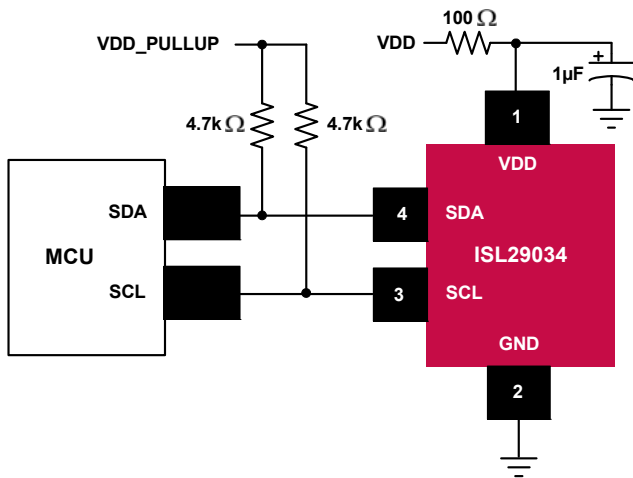

FIGURE 16. ISL29034 TYPICAL CIRCUIT

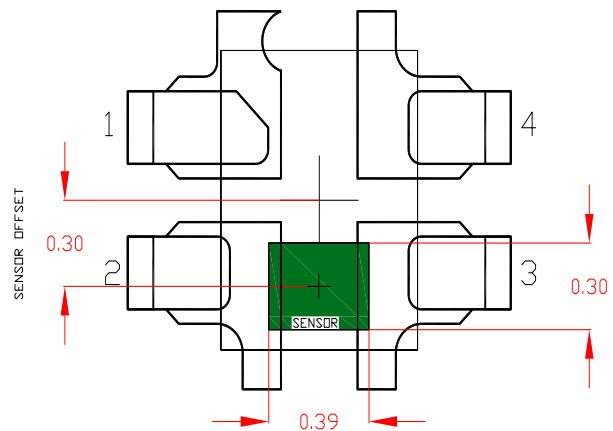

FIGURE 17. 4 LD ODFN SENSOR LOCATION OUTLINE

## Revision History

The revision history provided is for informational purposes only and is believed to be accurate, however, not warranted. Please go to web to make sure you have the latest revision.

DATE	REVISION	CHANGE
August 19, 2016	FN8370.2	<ul style="list-style-type: none"> <li>- Figure 2 on page 1: Updated y-axis titles.</li> <li>- On page 4: Added typical value of VOL (0.06)</li> <li>- On page 6: Corrected Figure 5 graph and label, corrected graph of Figure 6, corrected Figure 8 label (removed under F2 light source).</li> <li>- Added table of "key differences" on page 1.</li> <li>- Updated the L4.1.5x1.3 Package Outline Drawing to the latest revision: Tiebar Note updated From: Tiebar shown (if present) is a non-functional feature. To: Tiebar shown (if present) is a non-functional feature and may be located on any of the 4 sides (or ends).</li> </ul>
April 9, 2014	FN8370.1	Initial Release

## About Intersil

Intersil Corporation is a leading provider of innovative power management and precision analog solutions. The company's products address some of the largest markets within the industrial and infrastructure, mobile computing and high-end consumer markets.

For the most updated datasheet, application notes, related documentation and related parts, please see the respective product information page found at [www.intersil.com](http://www.intersil.com).

You may report errors or suggestions for improving this datasheet by visiting [www.intersil.com/ask](http://www.intersil.com/ask).

Reliability reports are also available from our website at [www.intersil.com/support](http://www.intersil.com/support).

© Copyright Intersil Americas LLC 2013-2016. All Rights Reserved.  
All trademarks and registered trademarks are the property of their respective owners.

For additional products, see [www.intersil.com/en/products.html](http://www.intersil.com/en/products.html)

Intersil products are manufactured, assembled and tested utilizing ISO9001 quality systems as noted in the quality certifications found at [www.intersil.com/en/support/qualandreliability.html](http://www.intersil.com/en/support/qualandreliability.html)

*Intersil products are sold by description only. Intersil may modify the circuit design and/or specifications of products at any time without notice, provided that such modification does not, in Intersil's sole judgment, affect the form, fit or function of the product. Accordingly, the reader is cautioned to verify that datasheets are current before placing orders. Information furnished by Intersil is believed to be accurate and reliable. However, no responsibility is assumed by Intersil or its subsidiaries for its use; nor for any infringements of patents or other rights of third parties which may result from its use. No license is granted by implication or otherwise under any patent or patent rights of Intersil or its subsidiaries.*

For information regarding Intersil Corporation and its products, see [www.intersil.com](http://www.intersil.com)

# Package Outline Drawing

## L4.1.5x1.3

4 LD 1.5X1.3 OPTICAL DUAL FLAT NO-LEAD (ODFN)

Rev 6, 4/15

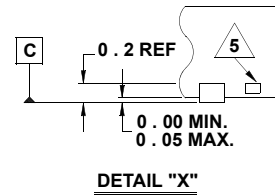
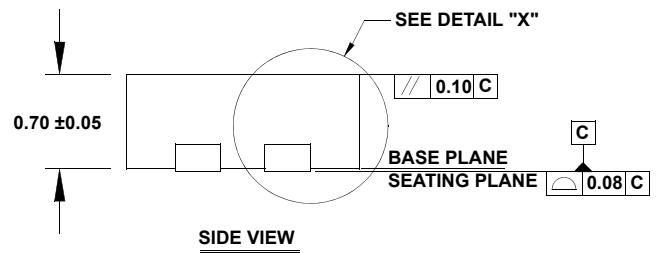
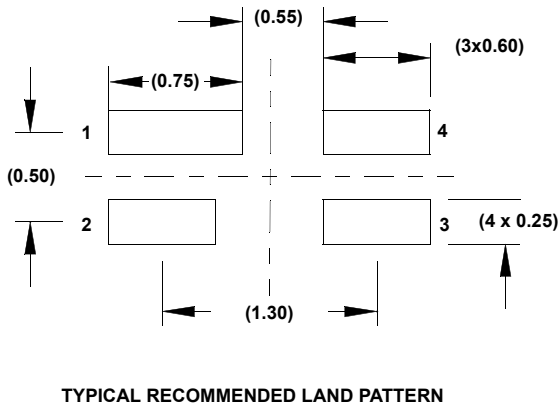
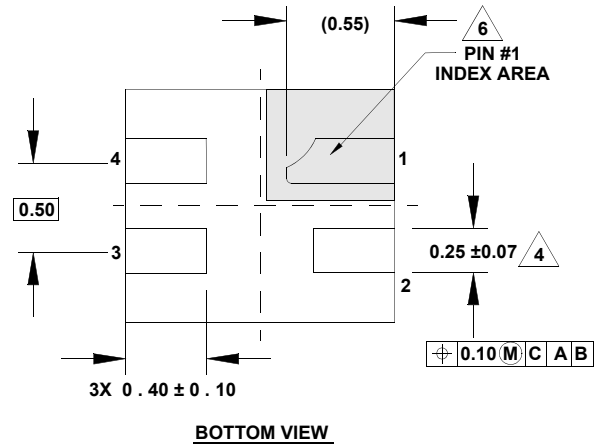
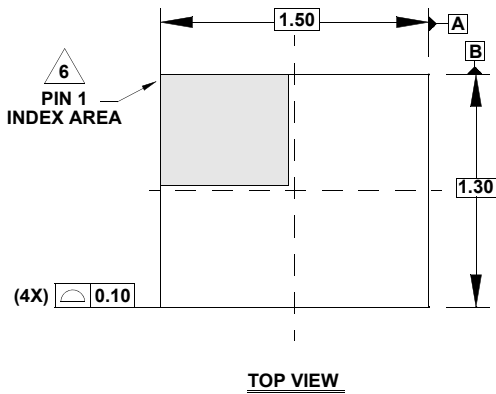

**NOTES:**

1. Dimensions are in millimeters.  
Dimensions in ( ) for Reference Only.
2. Dimensioning and tolerancing conform to AMSE Y14.5m-1994.
3. Unless otherwise specified, tolerance : Decimal  $\pm 0.05$
4. Dimension applies to the metallized terminal and is measured between 0.18mm and 0.32mm from the terminal tip.
5. Tiebar shown (if present) is a non-functional feature and may be located on any of the 4 sides (or ends).
6. The configuration of the pin #1 identifier is optional, but must be located within the zone indicated. The pin #1 identifier may be either a mold or mark feature.
7. This package not defined by JEDEC, but MO-229 can be used as a general reference.

## Looking for pricing, stock, or lifecycle information?

Click below to explore more details on WIN SOURCE:

-  [View ISL29034IROZ-T7 on WIN SOURCE](#)
-  [Renesas Electronics America](#) Information

## Optimize Your Supply Chain with WIN SOURCE Solutions

-  Global Sourcing Solution
-  Obsolete Management
-  Cost Control Management
-  Shortage Management
-  Alternative Solution
-  Excess Inventory Management