



**THE DATASHEET OF  
BA6427F-E2**



### DC Brushless Motor Driver Series for Cooling Fans

# Standard Single-phase Full-wave DC Brushless Fan Motor Drivers



## BA6427F,BA6428F,BA6908F,BA6906F,BA6423AF,BA6424AFS

#### ●Description

This is the summary of models of the single-phase full-wave fan motor driver with standard function. They incorporate lock protection and automatic restart circuit.

#### ●Features

- 1) Lock protection and automatic restart circuit
- 2) Soft switched drive(BA6908F、BA6906F)
- 3) Rotating speed pulse signal (FG) output (BA6427F、BA6908F、BA6424AFS)
- 4) Lock alarm signal (AL) output (BA6428F、BA6906F、BA6423AF、BA6424AFS)

#### ● Applications

For application of desktop PC and general consumer equipment

#### ●Lineup

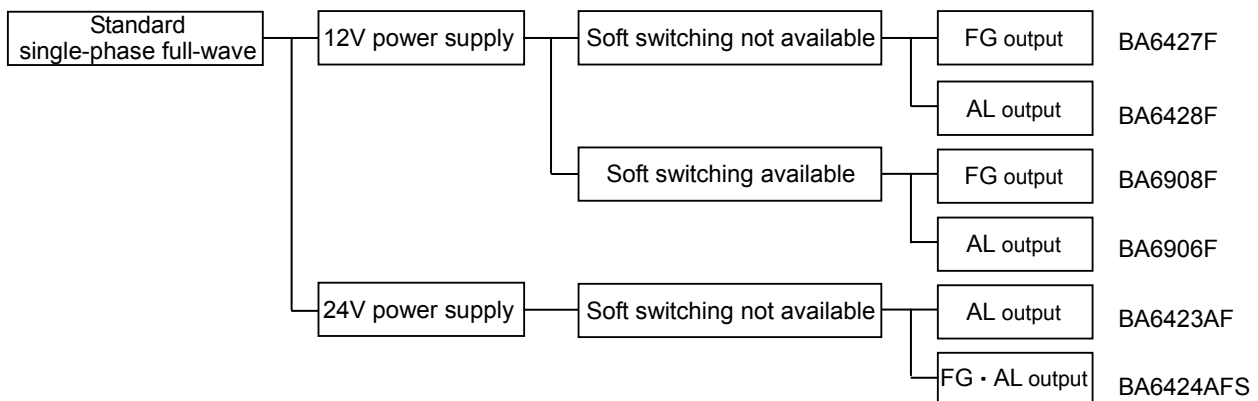

●Absolute Maximum Ratings

◎BA6427F, BA6428F

Parameter	Symbol	Limit	Unit
Supply voltage	Vcc	15	V
Power dissipation	Pd	780*	mW
Operation temperature	Topr	-40~+85	°C
Storage temperature	Tstg	-55~+150	°C
Low side output current	Iomax	0.7* *	A
Output voltage	VOUT	15	V
FG signal output current	IFG	15	mA
AL signal output current	IAL	15	mA
FG signal output voltage	VFG	15	V
AL signal output voltage	VAL	15	V
Junction temperature	Tjmax	150	°C

- \* Reduce by 6.24mW/°C over 25°C.  
(On 70.0mm×70.0mm×1.6mm glass epoxy board)
- \* \* This value is not to exceed Pd.

◎BA6908F, BA6906F

Parameter	Symbol	Limit	Unit
Supply voltage	Vcc	15	V
Power dissipation	Pd	780*	mW
Operation temperature	Topr	-40~+100	°C
Storage temperature	Tstg	-55~+150	°C
Output current	Iomax	0.7* *	A
Output voltage	VOUT	15	V
FG signal output current	IFG	15	mA
AL signal output current	IAL	15	mA
FG signal output voltage	VFG	15	V
AL signal output voltage	VAL	15	V
Junction temperature	Tjmax	150	°C

- \* Reduce by 6.24mW/°C over 25°C.  
(On 70.0mm×70.0mm×1.6mm glass epoxy board)
- \* \* This value is not to exceed Pd.

◎BA6423AF

Parameter	Symbol	Limit	Unit
Supply voltage	Vcc	30	V
Power dissipation	Pd	780*	mW
Operation temperature	Topr	-40~+100	°C
Storage temperature	Tstg	-55~+150	°C
Output current	Iomax	1.0* *	A
Output voltage	VOUT	30	V
AL signal output voltage	VAL	30	V
Junction temperature	Tjmax	150	°C

- \* Reduce by 6.24mW/°C over 25°C.  
(On 70.0mm×70.0mm×1.6mm glass epoxy board)
- \* \* This value is not to exceed Pd.

◎BA6424AFS

Parameter	Symbol	Limit	Unit
Supply voltage	Vcc	30	V
Power dissipation	Pd	812.5*	mW
Operation temperature	Topr	-40~+100	°C
Storage temperature	Tstg	-55~+150	°C
Output current	Iomax	1.0* *	A
Output voltage	VOUT	30	V
AL signal output voltage	VAL	30	V
FG signal output voltage	VFG	30	V
Junction temperature	Tjmax	150	°C

\* Reduce by 6.24mW/°C over 25°C.  
(On 70.0mm×70.0mm×1.6mm glass epoxy board)

\* \* This value is not to exceed Pd.

●OPERATING CONDITIONS

◎BA6427F, BA6428F

Parameter	Symbol	Limit	Unit
Operating supply voltage range	Vcc	3.0~14.0	V
Hall input voltage range	VH	0~Vcc-2.0	V

◎BA6908F, BA6906F

Parameter	Symbol	Limit	Unit
Operating supply voltage range	Vcc	3.0~14.0	V
Hall input voltage range	VH	0~Vcc-2.0	V

◎BA6423AF

Parameter	Symbol	Limit	Unit
Operating supply voltage range	Vcc	6.0~28.0	V
Hall input voltage range	VH	2.5~Vcc	V

◎BA6424AFS

Parameter	Symbol	Limit	Unit
Operating supply voltage range	Vcc	6.0~28.0	V
Hall input voltage range	VH	2.5~Vcc	V

●Truth table

◎BA6427F, BA6908F, BA6424AFS

H+	H-	OUT1	OUT2	FG
H	L	H	L	H
L	H	L	H	L

◎BA6428F, BA6906F, BA6423AF

H+	H-	OUT1	OUT2
H	L	H	L
L	H	L	H

● ELECTRICAL CHARACTERISTICS

◎BA6427F, BA6428F (Unless otherwise specified Ta=25°C, Vcc=5V)

Parameter	Symbol	Limit			Parameter	Conditions	Characteristics
		Min.	Typ.	Max.			
Circuit current	Icc	2.2	4.5	9.0	mA	At output OFF	Fig.1
Charge current of capacitor for lock detection	ILDC	1.60	2.90	4.64	μA	VLD=1.1V	Fig.2
Discharge current of capacitor for lock detection	ILDD	0.24	0.48	0.80	μA	VLD=1.1V	Fig.2
Charge-discharge current ratio of capacitor for lock detection	rCD	4.5	6.0	10.0	-	rCD=ILDC/ILDD	-
Clamp voltage of capacitor for lock detection	VLDC	1.27	1.93	2.60	V		Fig.3
Comparison voltage of capacitor for lock detection	VLDCP	0.47	0.76	1.06	V		Fig.3
Output voltage L	VOL	-	0.2	0.3	V	Io=200mA	Fig.4
Output voltage H	VOH	3.9	4.1	-	V	Io=-200mA	Fig.5
FG output voltage L	VFGL	-	0.3	0.5	V	IFG=5mA	-
AL output voltage L	VALL	-	0.3	0.5	V	IAL=5mA	-
FG output leak current	IFGL	-	0	50	μA	VFG=15V	-
AL output leak current	IALL	-	0	50	μA	VAL=15V	-

◎BA6908F, BA6906F (Unless otherwise specified Ta=25°C, Vcc=5V)

Parameter	Symbol	Limit			Parameter	Conditions	Characteristics
		Min.	Typ.	Max.			
Circuit current	Icc	1.5	3.4	8.7	mA	At output OFF	Fig.7
Charge current of capacitor for lock detection	ILDC	1.50	2.75	4.50	μA	VLD=1.1V	Fig.8
Discharge current of capacitor for lock detection	ILDD	0.24	0.48	0.90	μA	VLD=1.1V	Fig.8
Charge-discharge current ratio of capacitor for lock detection	rCD	4.2	5.7	9.5	-	rCD=ILDC/ILDD	-
Clamp voltage of capacitor for lock detection	VLDC	1.14	1.80	2.47	V		Fig.9
Comparison voltage of capacitor for lock detection	VLDCP	0.47	0.76	1.06	V		Fig.9
Output voltage L	VOL	-	0.2	0.3	V	Io=200mA	Fig.10
Output voltage H	VOH	3.9	4.1	-	V	Io=-200mA	Fig.11
FG output voltage L	VFGL	-	0.3	0.5	V	IFG=5mA	-
AL output voltage L	VALL	-	0.3	0.5	V	IAL=5mA	-
FG output leak current	IFGL	-	0	50	μA	VFG=15V	-
AL output leak current	IALL	-	0	50	μA	VAL=15V	-
Hall input offset voltage	Hofs	-10	-	10	mV		-
Hall input-output gain	GHO	320	500	680	-		-

©BA6423AF (Unless otherwise specified Ta=25°C, Vcc=12V)

Parameter	Symbol	Limit			Parameter	Conditions	Characteristics
		Min.	Typ.	Max.			
Circuit current	I <sub>CC</sub>	2.7	5.4	8.1	mA	At output OFF	Fig.13
Charge current of capacitor for lock detection	I <sub>LDC</sub>	1.55	3.10	4.65	μA	V <sub>LD</sub> =1.8V	-
Discharge current of capacitor for lock detection	I <sub>LDD</sub>	0.33	0.66	0.99	μA	V <sub>LD</sub> =1.8V	-
Charge-discharge current ratio of capacitor for lock detection	r <sub>CD</sub>	3.0	4.7	6.4	-	r <sub>CD</sub> =I <sub>LDC</sub> /I <sub>LDD</sub>	-
Clamp voltage of capacitor for lock detection	V <sub>LDCL</sub>	2.00	2.48	3.00	V		-
Comparison voltage of capacitor for lock detection	V <sub>LDCP</sub>	0.70	0.99	1.30	V		-
Output voltage L	V <sub>OL</sub>	-	0.8	1.2	V	I <sub>o</sub> =200mA	Fig.14
Output voltage H	V <sub>OH</sub>	-	0.9	1.4	V	I <sub>o</sub> =-200mA	Fig.15
AL output voltage L	V <sub>ALL</sub>	-	0.1	0.3	V	I <sub>AL</sub> =10mA	Fig.16
AL output leak current	I <sub>ALL</sub>	-	0	10	μA	V <sub>AL</sub> =30V	-

©BA6424AFS (Unless otherwise specified Ta=25°C, Vcc=12V)

Parameter	Symbol	Limit			Parameter	Conditions	Characteristics
		Min.	Typ.	Max.			
Circuit current	I <sub>CC</sub>	2.7	5.4	8.1	mA	At output OFF	Fig.19
Charge current of capacitor for lock detection	I <sub>LDC</sub>	1.55	3.10	4.65	μA	V <sub>LD</sub> =1.8V	-
Discharge current of capacitor for lock detection	I <sub>LDD</sub>	0.33	0.66	0.99	μA	V <sub>LD</sub> =1.8V	-
Charge-discharge current ratio of capacitor for lock detection	r <sub>CD</sub>	3.0	4.7	6.4	-	r <sub>CD</sub> =I <sub>LDC</sub> /I <sub>LDD</sub>	-
Clamp voltage of capacitor for lock detection	V <sub>LDCL</sub>	2.00	2.48	3.00	V		-
Comparison voltage of capacitor for lock detection	V <sub>LDCP</sub>	0.70	0.99	1.30	V		-
Output voltage L	V <sub>OL</sub>	-	0.8	1.2	V	I <sub>o</sub> =200mA	Fig.20
Output voltage H	V <sub>OH</sub>	-	0.9	1.4	V	I <sub>o</sub> =-200mA	Fig.21
AL output voltage L	V <sub>ALL</sub>	-	0.1	0.3	V	I <sub>AL</sub> =10mA	Fig.22
AL output leak current	I <sub>ALL</sub>	-	0	10	μA	V <sub>AL</sub> =30V	-
FG output voltage L	V <sub>FGL</sub>	-	0.1	0.3	V	I <sub>FG</sub> =10mA	Fig.22
FG output leak current	I <sub>FGL</sub>	-	0	10	μA	V <sub>FG</sub> =30V	-

◎BA6427F/BA6428F

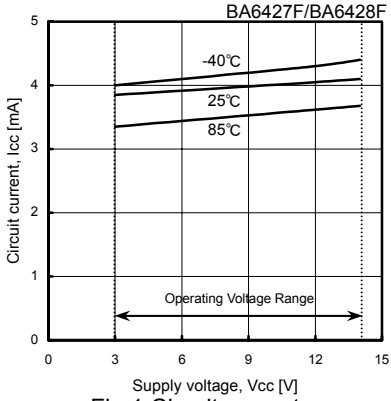

Fig.1 Circuit current

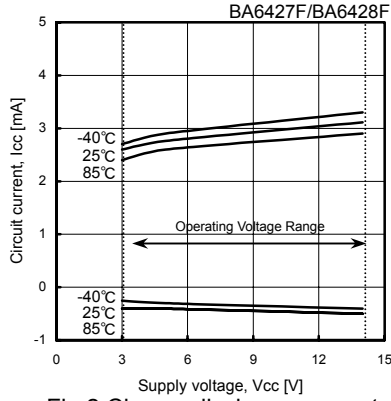

Fig.2 Charge-discharge current of capacitor for lock detection

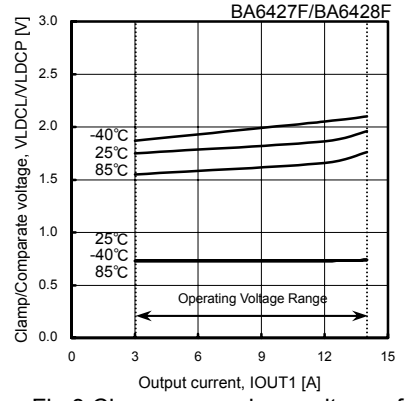

Fig.3 Clamp-compare voltage of capacitor for lock detection

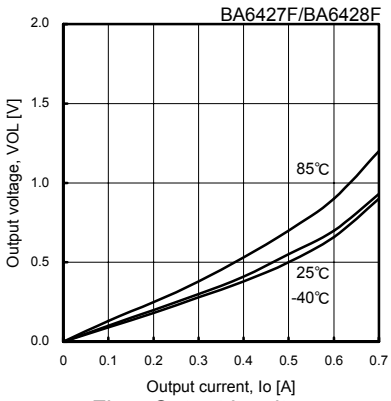

Fig.4 Output L voltage

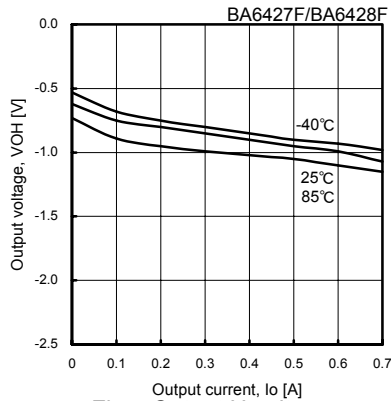

Fig.5 Output H voltage

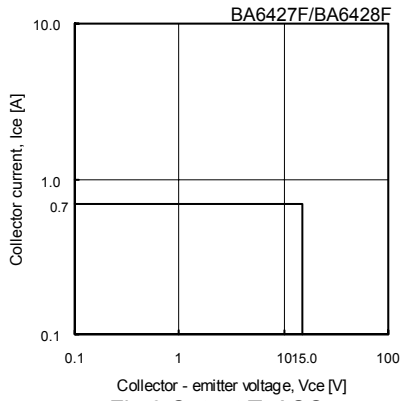

Fig.6 Output Tr ASO (Ton=100msec)

◎BA6908F/BA6906F

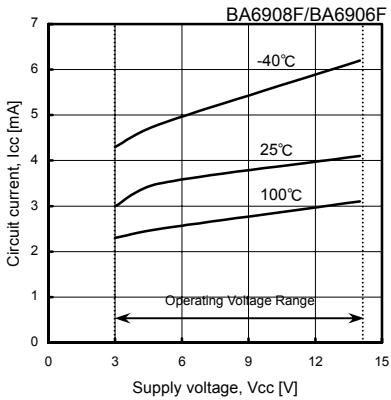

Fig.7 Circuit current

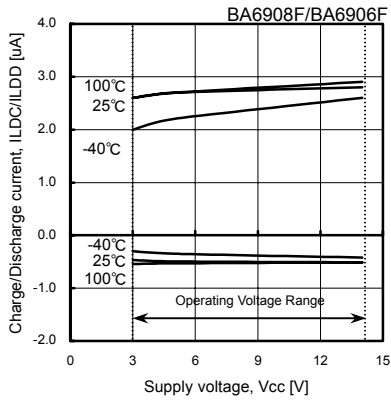

Fig.8 Charge-discharge current of capacitor for lock detection

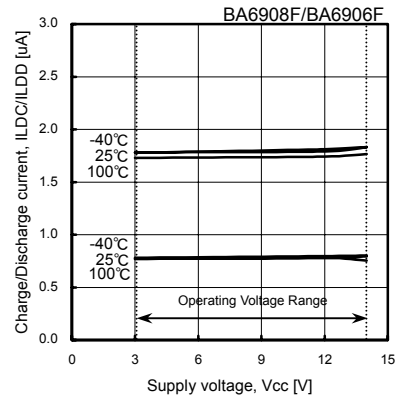

Fig.9 Clamp-compare voltage of capacitor for lock detection

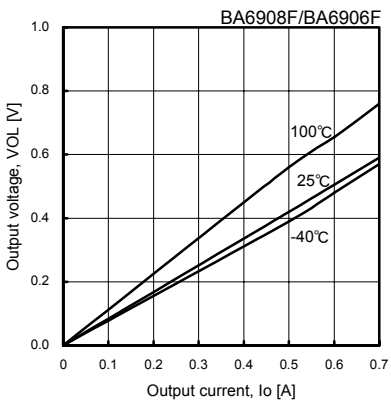

Fig.10 Output L voltage

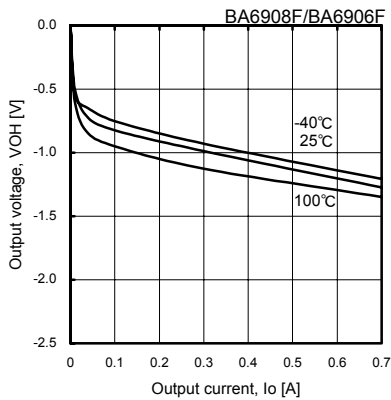

Fig.11 Output H voltage

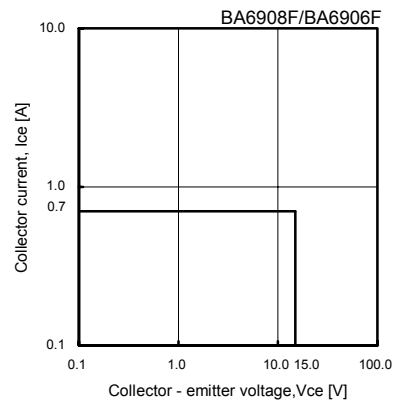

Fig.12 Output Tr ASO (Ton=100msec)

©BA6423AF

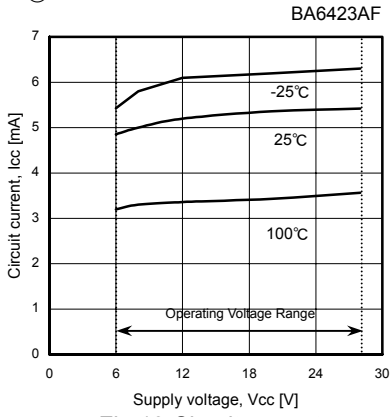

Fig. 13 Circuit current

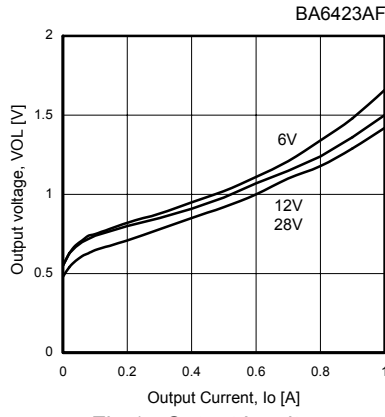

Fig. 14 Output L voltage

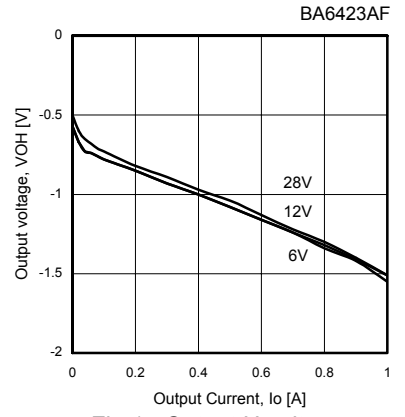

Fig. 15 Output H voltage

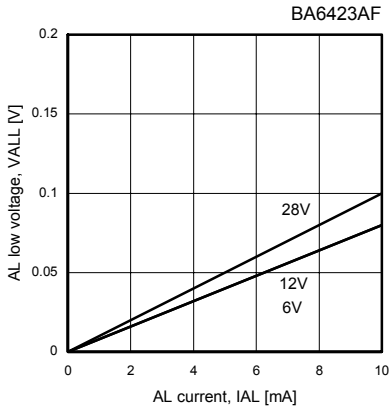

Fig. 16 AL Output L voltage

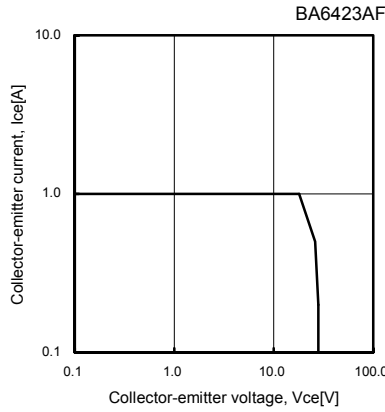

Fig. 17 Output Tr ASO (upper)  
(TON=100msec)

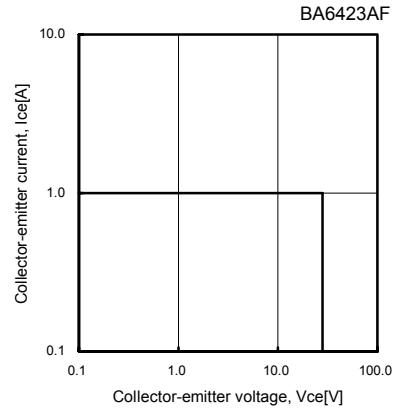

Fig. 18 Output Tr ASO (lower)  
(TON=100msec)

©BA6424AFS

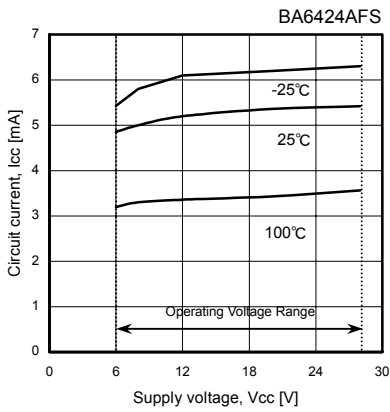

Fig. 19 Circuit current

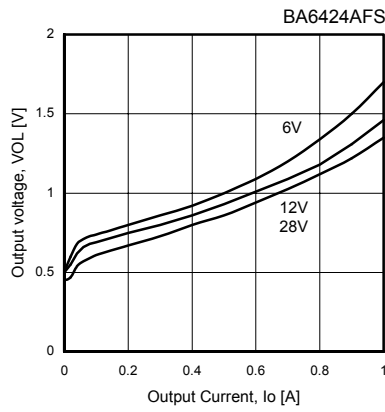

Fig. 20 Output L voltage

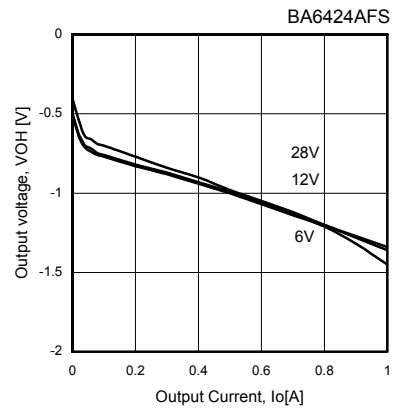

Fig. 21 Output H voltage

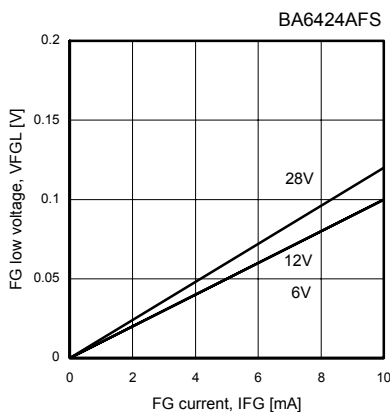

Fig. 22 FG/AL Output L voltage

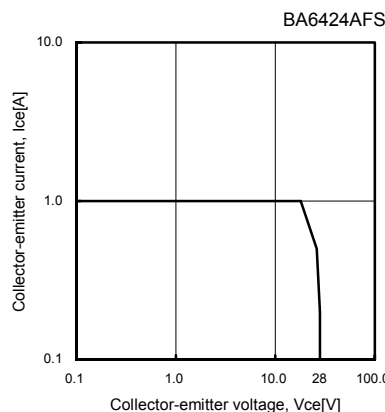

Fig. 23 Output Tr ASO (upper)  
(TON=100msec)

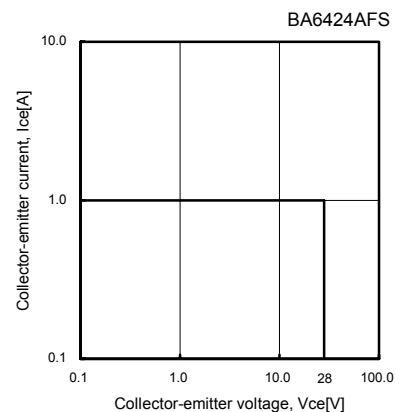
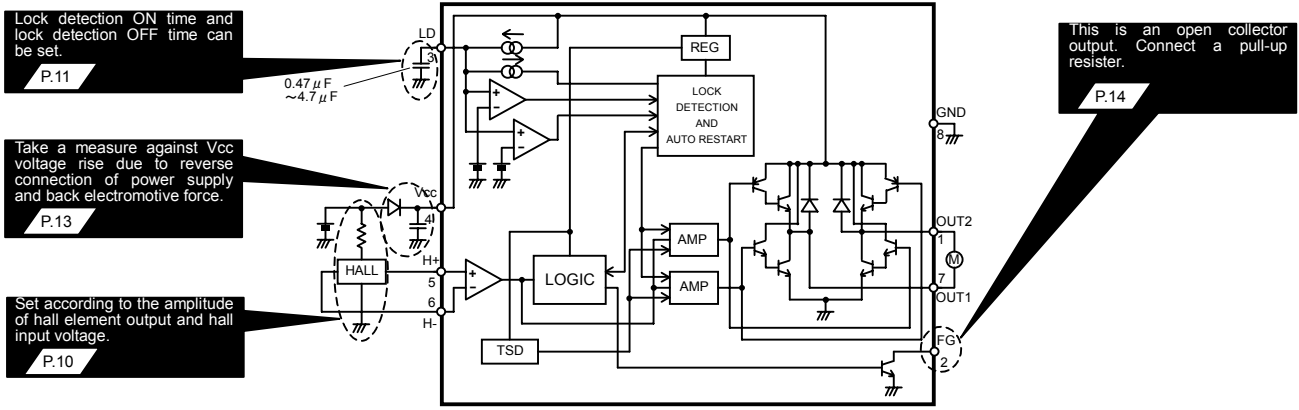

Fig. 24 Output Tr ASO (lower)  
(TON=100msec)

●Block diagram, application circuit, and pin assignment(Constant etc are for reference)

©BA6427F、BA6428F



REG : Internal reference voltage TSD : Thermal shutdown(heat rejection circuit)

PIN No.	Terminal name	Function
1	OUT2	Motor output terminal 2
2	FG/AL	Rotating speed pulse signal/Lock alarm signal output terminal
3	LD	Lock detection and automatic restart capacitor connecting terminal
4	Vcc	Power supply terminal
5	H+	Hall input terminal +
6	H-	Hall input terminal -
7	OUT1	Motor output terminal 1
8	GND	GND terminal

©BA6908F、BA6906F

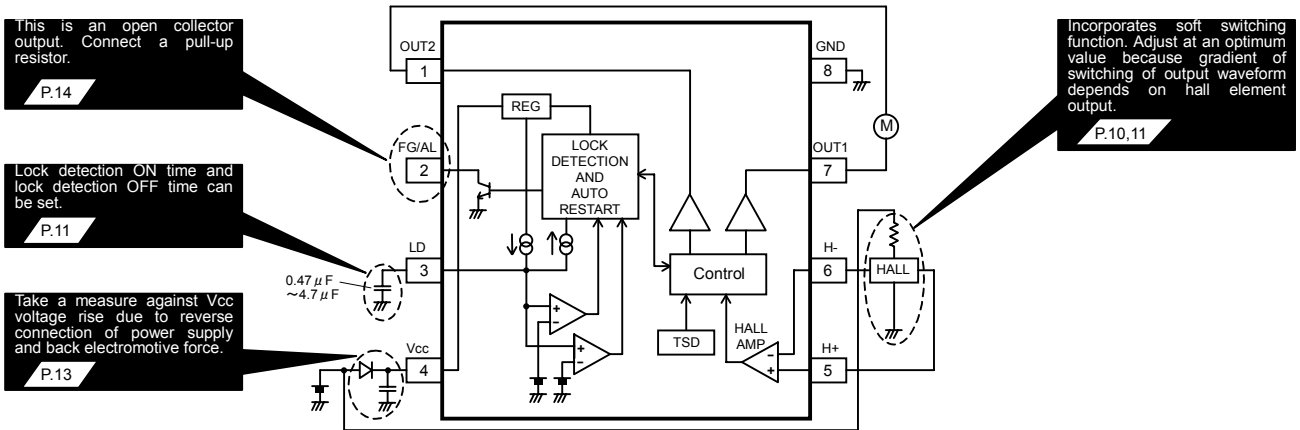

REG : Internal reference voltage TSD : Thermal shutdown(heat rejection circuit)

PIN No.	Terminal name	Function
1	OUT2	Motor output terminal 2
2	FG/AL	Rotating speed pulse signal/Lock alarm signal output terminal
3	LD	Lock detection and automatic restart capacitor connecting terminal
4	Vcc	Power supply terminal
5	H+	Hall input terminal +
6	H-	Hall input terminal -
7	OUT1	Motor output terminal 1
8	GND	GND terminal

©BA6423AF

Capacitor for setting lock detecting and auto restart time.  
P.11

Take a measure against Vcc voltage rise generated by reverse connection of current and counter electromotive force.  
P.13

Set according to the amplitude of hall element output and hall input voltage range.  
P.10

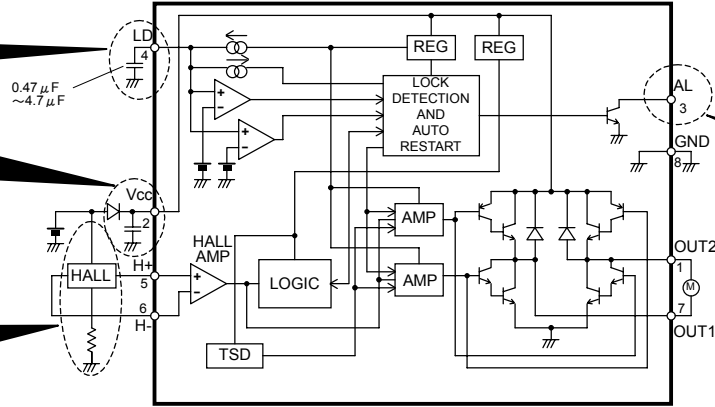

This is an open collector output. Connect a pull-up resistor.  
P.14

PIN No.	Terminal name	Function
1	OUT2	Motor output terminal2
2	Vcc	Power supply terminal
3	AL	Lock alarm signal output terminal
4	LD	Lock detecting and auto restart capacitor connecting terminal
5	H+	Hall input terminal+
6	H-	Hall input terminal-
7	OUT1	Motor output terminal1
8	GND	GND terminal

©BA6424AFS

Capacitor for setting lock detecting and auto restart time.  
P.11

Take a measure against Vcc voltage rise generated by reverse connection of current and counter electromotive force.  
P.13

Set according to the amplitude of hall element output and hall input voltage range.  
P.10

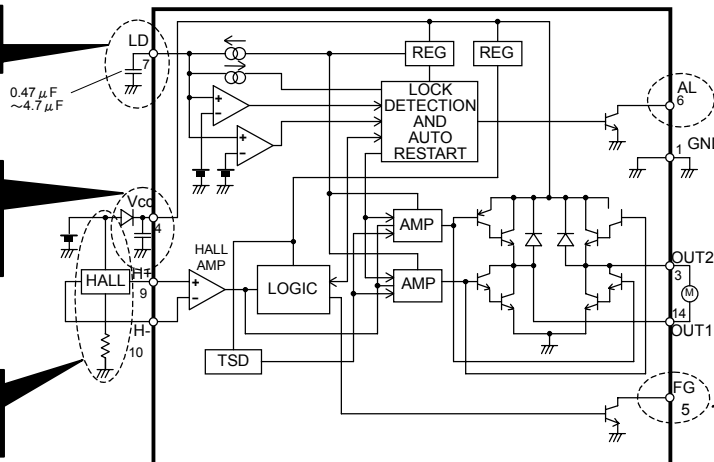

This is an open collector output. Connect a pull-up resistor.  
P.14

PIN No.	Terminal name	Function	PIN No.	Terminal name	Function
1	GND	GND terminal	9	H+	Hall input terminal+
2	N.C.		10	H-	Hall input terminal-
3	OUT2	Motor output terminal2	11	N.C.	
4	Vcc	Power supply terminal	12	N.C.	
5	FG	Rotating speed pulse signal output terminal	13	N.C.	
6	AL	Lock alarm signal output terminal	14	OUT1	Motor output terminal1
7	LD	Lock detection and auto restart capacitor connecting terminal	15	N.C.	
8	N.C.		16	N.C.	

●Description of operations

Function table

	BA6427F	BA6428F	BA6908F	BA6906F	BA6423AF	BA6424AFS	Reference page
Lock protection and automatic restart	○	○	○	○	○	○	P.10
Soft switching function			○	○			P.10
FG output	○		○			○	P.14
AL output		○		○	○	○	P.14

1) Lock protection and automatic restart

Lock detection ON time (TON) and lock detection OFF time (TOFF) is set by charging and discharging of external capacitor of LD terminal.

$$\text{TON(Lock detection ON time)} = \frac{C \cdot (\text{VLDCL} - \text{VLDPC})}{\text{ILDC}}$$

$$\text{TOFF(Lock detection OFF time)} = \frac{C \cdot (\text{VLDCL} - \text{VLDPC})}{\text{ILDD}}$$

C : Capacity of capacitor equipped externally on LD terminal  
 VLDCL : LD terminal clamping voltage  
 VLDPC : LD terminal comparator voltage  
 ILDC : LD terminal charging current  
 ILDD : terminal discharging current

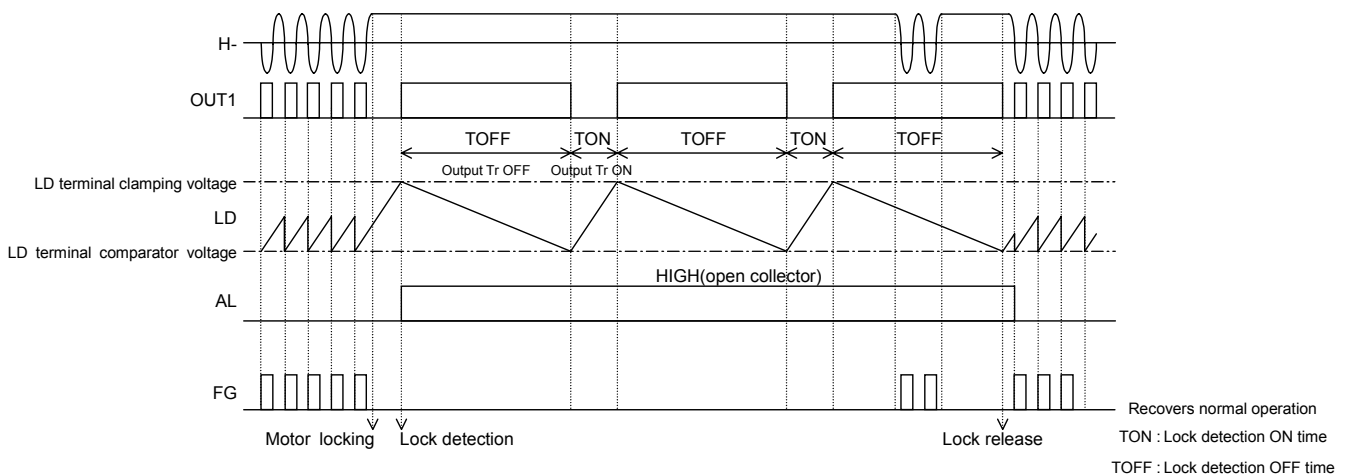

Fig.25 Lock protection (CR timer system) timing chart

2) Soft switching (silent drive setting) <BA6908F, BA6906F>

Input signal to hall amplifier is amplified to produce an output signal.

When the hall element output signal is small, the gradient of switching of output waveform is gentle; When it is large on the contrary, the gradient of switching of output waveform is steep. Gain of 500 times (typical value) is provided between input and output, therefore enter an appropriate hall element output to IC where output waveform swings sufficiently.

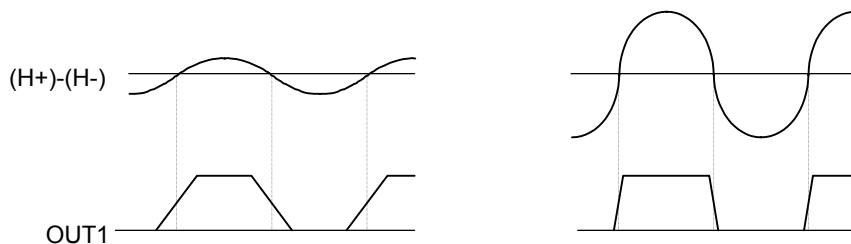

Fig.26 Relation between hall element output amplitude and output waveform

### 3) Hall input setting

Hall input voltage range is shown in operating conditions.

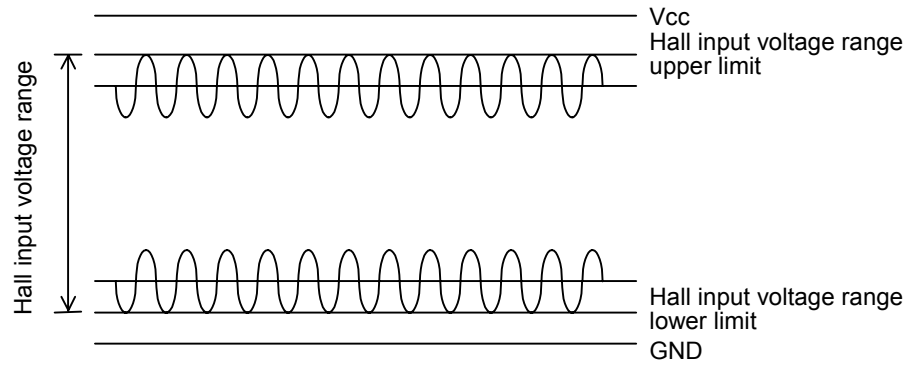
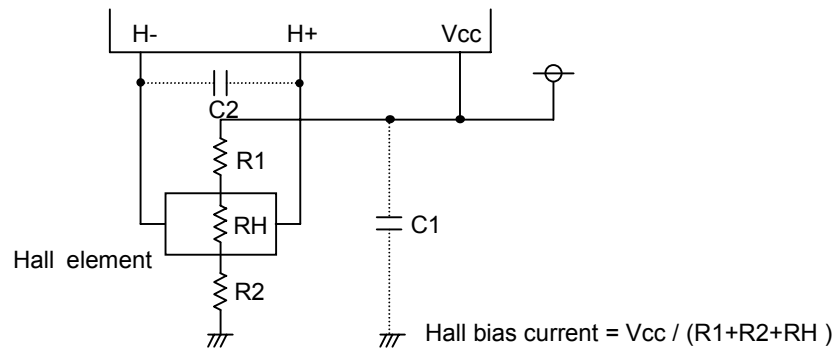

Fig.27 Hall input voltage range

Adjust the value of hall element bias resistor R1 and R2 in Fig 28 so that the input voltage of a hall amplifier is input in "hall input voltage range" including signal amplitude.

#### ○Reducing the noise of hall signal

Hall element may be affected by Vcc noise or the like depending on the wiring pattern of board. In this case, place a capacitor like C1 in Fig 28. In addition, when wiring from the hall element output to IC hall input is long, noise may be loaded on wiring. In this case, place a capacitor like C2 in Fig. 28.



Setting R2=0 ohm is acceptable for BA6427F, BA6428F, BA6908F, and BA6906F.  
 Setting R1=0 ohm is acceptable for BA6423AF and BA6424AFS.

Fig.28 Application near hall signal

●Equivalent circuit

©BA6427F, BA6428F, BA6908F, BA6906F

1) Hall input terminal

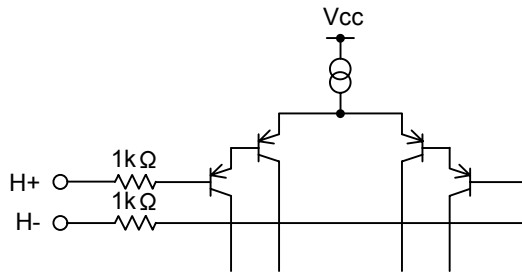

2) Motor output terminal

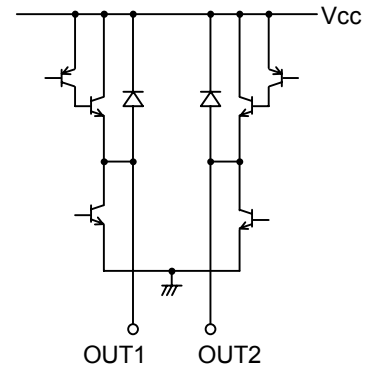

3) FG signal output terminal or  
AL signal output terminal

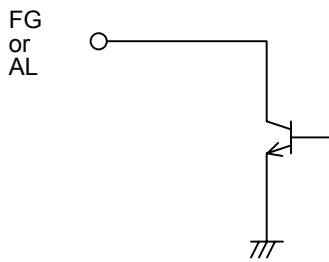

©BA6423AF, BA6424AFS

1) Hall input terminal

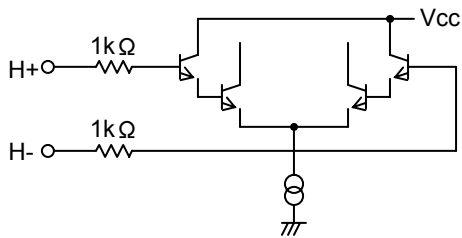

2) Motor output terminal

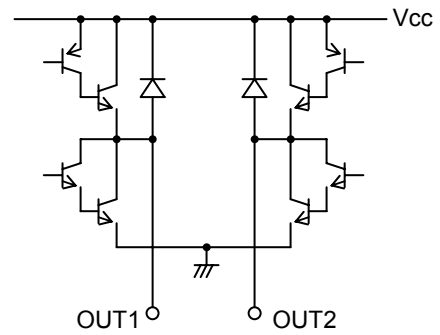

3) FG output terminal

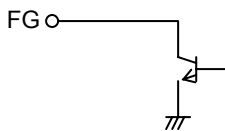

4) AL output terminal

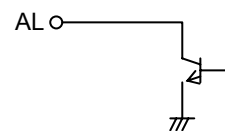

● Safety measure

1) Reverse connection protection diode

Reverse connection of power results in IC destruction as shown in Fig 29. When reverse connection is possible, reverse connection protection diode must be added between power supply and Vcc.

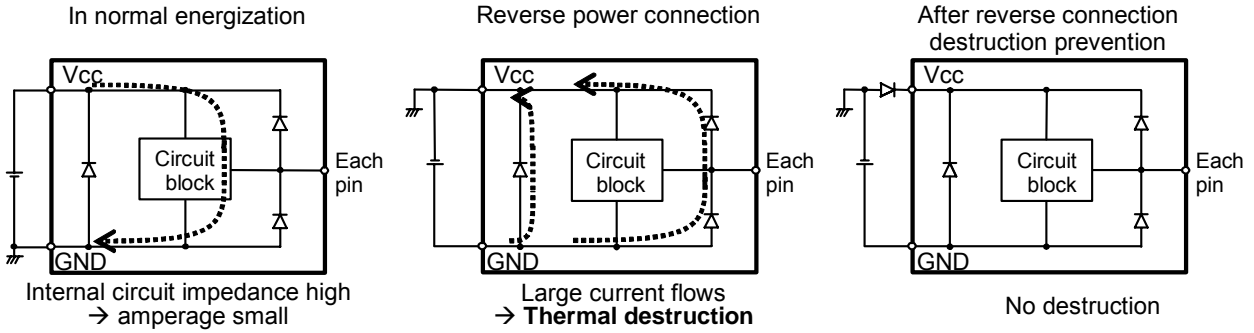

Fig.29 Flow of current when power is connected reversely

2) Measure against Vcc voltage rise by back electromotive force

Back electromotive force (Back EMF) generates regenerative current to power supply. However, when reverse connection protection diode is connected, Vcc voltage rises because the diode prevents current flow to power supply.

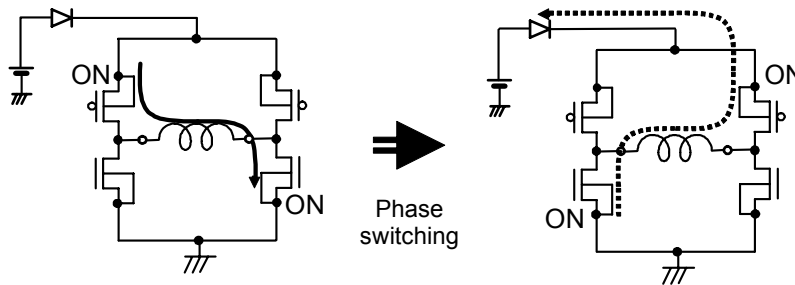

Fig.30 Vcc voltage rise by back electromotive force

When the absolute maximum rated voltage may be exceeded due to voltage rise by back electromotive force, place (A) Capacitor or (B) Zener diode between Vcc and GND. It necessary, add both (C).

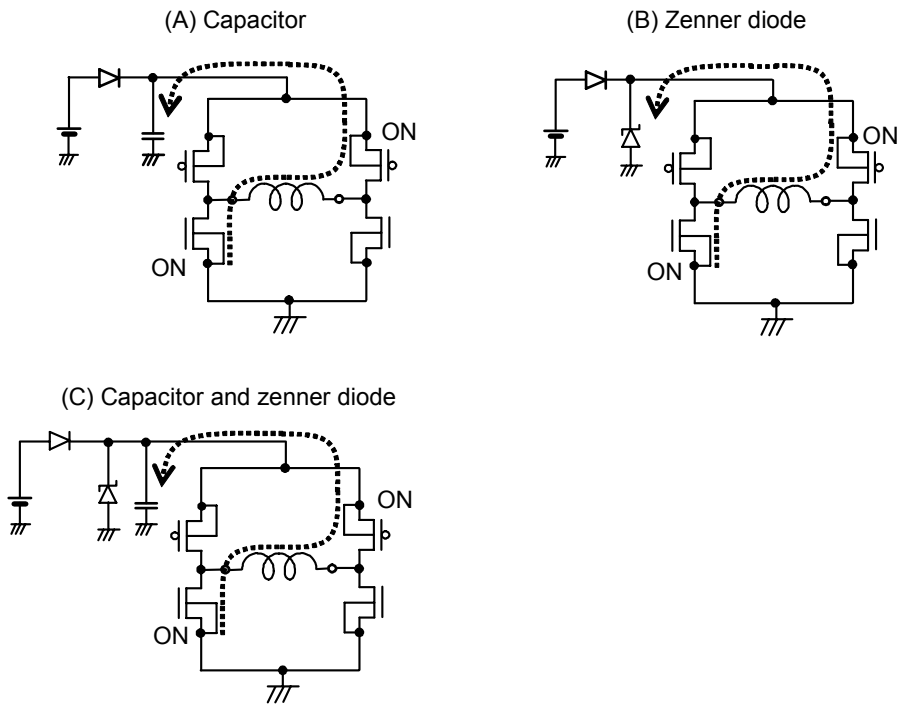

Fig31. Measure against Vcc voltage rise

3) Problem of GND line PWM switching

Do not perform PWM switching of GND line because GND terminal potential cannot be kept to a minimum.

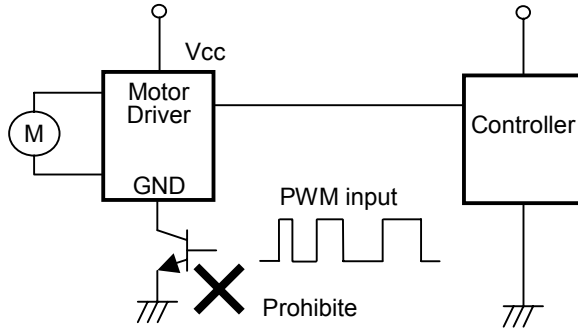

Fig.32 GND line PWM switching prohibited

4) FG and AL output

FG and AL output is an open collector and requires pull-up resistor.

The IC can be protected by adding resistor R1. An excess of absolute maximum rating, when FG or AL output terminal is directly connected to power supply, could damage the IC.

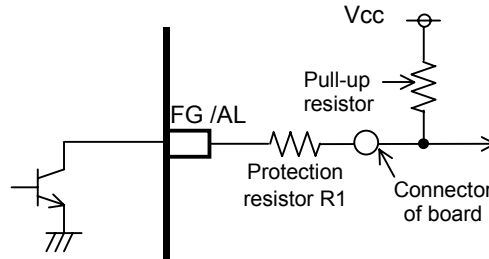

Fig.33 Protection of FG and AL terminal

● Thermal derating curve

Thermal derating curve indicates power that can be consumed by IC with reference to ambient temperature. Power that can be consumed by IC begins to attenuate at certain ambient temperature. This gradient is determined by thermal resistance  $\theta_{ja}$ .

Thermal resistance  $\theta_{ja}$  depends on chip size, power consumption, package ambient temperature, packaging condition, wind velocity, etc., even when the same package is used. Thermal derating curve indicates a reference value measured at a specified condition. Fig.34 shows a thermal derating curve.

(Value when mounting FR4 glass epoxy board 70 [mm] x 70 [mm] x 1.6 [mm] (copper foil area below 3 [%]))

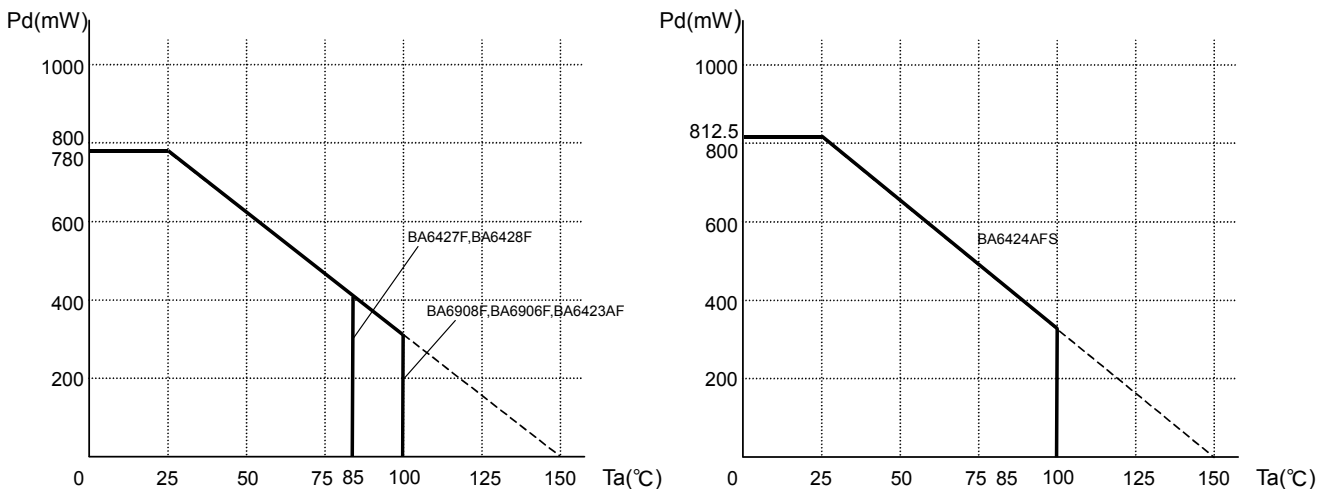

\* Reduce by 6.24mW/°C over 25°C.<BA6427F, BA6428F, BA6908F, BA6906F, BA6423AF>

\* Reduce by 6.5mW/°C over 25°C.<BA6424AFS>

(On 70.0mm x 70.0mm x 1.6mm glass epoxy board)

Fig.34 Thermal derating curve

## ●Cautions on use

### 1) Absolute maximum ratings

An excess in the absolute maximum ratings, such as supply voltage, temperature range of operating conditions, etc., can break down the devices, thus making impossible to identify breaking mode, such as a short circuit or an open circuit. If any over rated values will expect to exceed the absolute maximum ratings, consider adding circuit protection devices, such as fuses.

### 2) Connecting the power supply connector backward

Connecting of the power supply in reverse polarity can damage IC. Take precautions when connecting the power supply lines. An external direction diode can be added.

### 3) Power supply line

Back electromotive force causes regenerated current to power supply line, therefore take a measure such as placing a capacitor between power supply and GND for routing regenerated current. And fully ensure that the capacitor characteristics have no problem before determine a capacitor value. (when applying electrolytic capacitors, capacitance characteristic values are reduced at low temperatures)

### 4) GND potential

The potential of GND pin must be minimum potential in all operating conditions. Also ensure that all terminals except GND terminal do not fall below GND voltage including transient characteristics. However, it is possible that the motor output terminal may deflect below GND because of influence by back electromotive force of motor. Malfunction may possibly occur depending on use condition, environment, and property of individual motor. Please make fully confirmation that no problem is found on operation of IC.

### 5) Thermal design

Use a thermal design that allows for a sufficient margin in light of the power dissipation(Pd) in actual operating conditions.

### 6) Inter-pin shorts and mounting errors

Use caution when positioning the IC for mounting on printed circuit boards. The IC may be damaged if there is any connection error or if pins are shorted together.

### 7) Actions in strong electromagnetic field

Use caution when using the IC in the presence of a strong electromagnetic field as doing so may cause the IC to malfunction.

### 8) ASO

When using the IC, set the output transistor so that it does not exceed absolute maximum ratings or ASO.

### 9) Thermal shut down circuit

The IC incorporates a built-in thermal shutdown circuit (TSD circuit). Operation temperature is 175°C(typ.) and has a hysteresis width of 25°C(typ.). When IC chip temperature rises and TSD circuit works, the output terminal becomes an open state. TSD circuit is designed only to shut the IC off to prevent thermal runaway. It is not designed to protect the IC or guarantee its operation. Do not continue to use the IC after operation this circuit or use the IC in an environment where the operation of this circuit is assumed.

### 10) Testing on application boards

When testing the IC on an application board, connecting a capacitor to a pin with low impedance subjects the IC to stress. Always discharge capacitors after each process or step. Always turn the IC's power supply off before connecting it to or removing it from a jig or fixture during the inspection process. Ground the IC during assembly steps as an antistatic measure. Use similar precaution when transporting or storing the IC.

### 11) GND wiring pattern

When using both small signal and large current GND patterns, it is recommended to isolate the two ground patterns, placing a single ground point at the ground potential of application so that the pattern wiring resistance and voltage variations caused by large currents do not cause variations in the small signal ground voltage. Be careful not to change the GND wiring pattern of any external components, either.

### 12) Capacitor between output and GND

When a large capacitor is connected between output and GND, if Vcc is shorted with 0V or GND for some cause, it is possible that the current charged in the capacitor may flow into the output resulting in destruction. Keep the capacitor between output and GND below 100uF.

### 13) IC terminal input

When Vcc voltage is not applied to IC, do not apply voltage to each input terminal. When voltage above Vcc or below GND is applied to the input terminal, parasitic element is actuated due to the structure of IC. Operation of parasitic element causes mutual interference between circuits, resulting in malfunction as well as destruction in the last. Do not use in a manner where parasitic element is actuated.

### 14) In use

We are sure that the example of application circuit is preferable, but please check the character further more in application to a part which requires high precision. In using the unit with external circuit constant changed, consider the variation of externally equipped parts and our IC including not only static character but also transient character and allow sufficient margin in determining.

● Ordering part number

· Please order by ordering part number. · Please confirm the combination of each items. · Please write the letter close to left when column is blank.

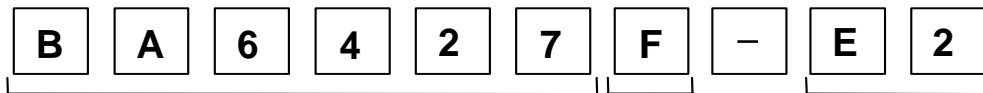

Part Number		Package Type	Package specification
• BA6427	• BA6428	• F : SOP8	E2 Emboss tape read Pin 1 opposite draw-out side
• BA6908	• BA6906	• FS : SSOP-A16	
• BA6423A	• BA6424A		

● PHYSICAL DIMENSION

SOP8

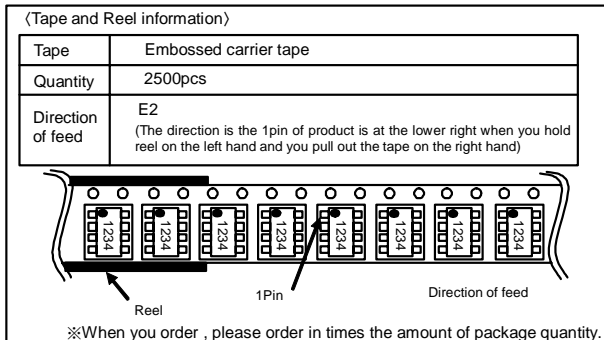
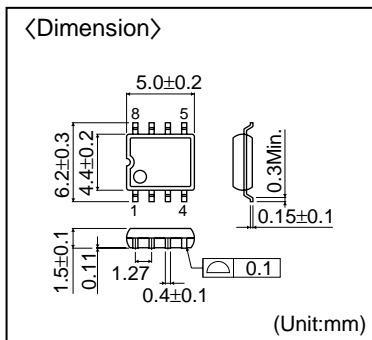

SSOP-A16

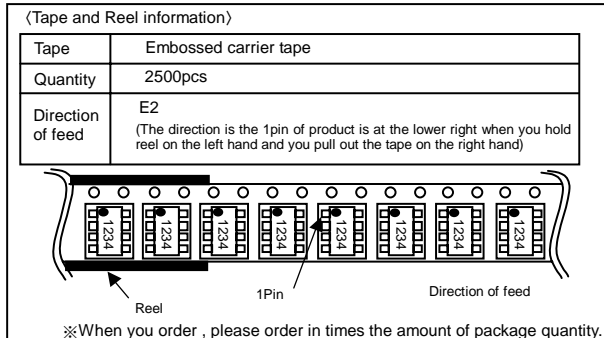
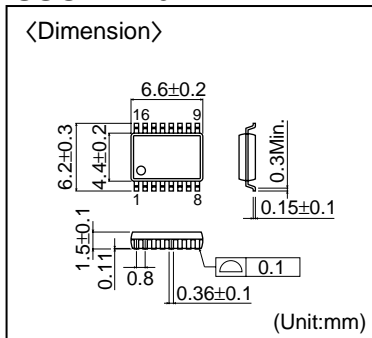

- The contents described herein are correct as of January, 2007
- The contents described herein are subject to change without notice. For updates of the latest information, please contact and confirm with ROHM CO.,LTD.
- Any part of this application note must not be duplicated or copied without our permission.
- Application circuit diagrams and circuit constants contained herein are shown as examples of standard use and operation. Please pay careful attention to the peripheral conditions when designing circuits and deciding upon circuit constants in the set.
- Any data, including, but not limited to application circuit diagrams and information, described herein are intended only as illustrations of such devices and not as the specifications for such devices. ROHM CO.,LTD. disclaims any warranty that any use of such devices shall be free from infringement of any third party's intellectual property rights or other proprietary rights, and further, assumes no liability of whatsoever nature in the event of any such infringement, or arising from or connected with or related to the use of such devices.
- Upon the sale of any such devices, other than for buyer's right to use such devices itself, resell or otherwise dispose of the same, implied right or license to practice or commercially exploit any intellectual property rights or other proprietary rights owned or controlled by ROHM CO., LTD. is granted to any such buyer.
- The products described herein utilize silicon as the main material.
- The products described herein are not designed to be X ray proof.

The products listed in this catalog are designed to be used with ordinary electronic equipment or devices (such as audio visual equipment, office-automation equipment, communications devices, electrical appliances and electronic toys). Should you intend to use these products with equipment or devices which require an extremely high level of reliability and the malfunction of which would directly endanger human life (such as medical instruments, transportation equipment, aerospace machinery, nuclear-reactor controllers, fuel controllers and other safety devices), please be sure to consult with our sales representative in advance.

Contact us for further information about the products.

Excellence in Electronics



ROHM CO., LTD.

21, Saiin Mizosaki-cho, Ukyo-ku, Kyoto  
615-8585, Japan  
TEL: +81-75-311-2121 FAX: +81-75-315-0172  
URL: http://www.rohm.com

Published by  
LSI Business Promotion Dept.

<b>Seoul</b>	TEL: +82-2-8182-700	FAX: +82-2-8182-715	<b>Bangkok</b>	TEL: +66-2-254-4890	FAX: +66-2-256-6334
<b>Masan</b>	TEL: +82-55-240-6234	FAX: +82-55-240-6236	<b>Kuala Lumpur</b>	TEL: +60-3-7958-8355	FAX: +60-3-7958-8377
<b>Dalian</b>	TEL: +86-411-8230-8549	FAX: +86-411-8230-8537	<b>Penang</b>	TEL: +60-4-6585084	FAX: +60-4-6585167
<b>Beijing</b>	TEL: +86-10-8525-2483	FAX: +86-10-8525-2489	<b>Dusseldorf</b>	TEL: +49-2145-9210	FAX: +49-2154-921400
<b>Tianjin</b>	TEL: +86-22-23029181	FAX: +86-22-23029183	<b>Munich</b>	TEL: +49-8161-48310	FAX: +49-8161-483120
<b>Shanghai</b>	TEL: +86-21-6279-2727	FAX: +86-21-6247-2066	<b>Stuttgart</b>	TEL: +49-711-72723710	FAX: +49-711-72723720
<b>Hangzhou</b>	TEL: +86-571-87658072	FAX: +86-571-87658071	<b>France</b>	TEL: +33-1-5697-3060	FAX: +33-1-5697-3080
<b>Nanjing</b>	TEL: +86-25-8689-0015	FAX: +86-25-8689-0393	<b>United Kingdom</b>	TEL: +44-1-908-306700	FAX: +44-1-908-235788
<b>Ningbo</b>	TEL: +86-574-87654201	FAX: +86-574-87654208	<b>Denmark</b>	TEL: +45-3694-4739	FAX: +45-3694-4789
<b>Qingdao</b>	TEL: +86-532-5779-312	FAX: +86-532-5779-653	<b>Barcelona</b>	TEL: +34-9375-24320	FAX: +34-9375-24410
<b>Suzhou</b>	TEL: +86-512-6807-1300	FAX: +86-512-6807-2300	<b>Malaga</b>	TEL: +34-9520-20263	FAX: +34-9520-20023
<b>Tianjin</b>	TEL: +86-22-23029181	FAX: +86-22-23029183	<b>Hungary</b>	TEL: +36-1-4719338	FAX: +36-1-4719339
<b>Wuxi</b>	TEL: +86-510-82702693	FAX: +86-510-82702992	<b>Poland</b>	TEL: +48-22-5757213	FAX: +48-22-5757001
<b>Hong Kong</b>	TEL: +852-2-740-6262	FAX: +852-2-375-8971	<b>Russia</b>	TEL: +7-95-980-6755	FAX: +7-95-937-8290
<b>Dongguan</b>	TEL: +86-769-393-3320	FAX: +86-769-398-4140	<b>San Diego</b>	TEL: +1-858-625-3630	FAX: +1-858-625-3670
<b>Fuzhou</b>	TEL: +86-591-8901-8698	FAX: +86-591-8901-8690	<b>Atlanta</b>	TEL: +1-770-754-5972	FAX: +1-770-754-0691
<b>Guangzhou</b>	TEL: +86-20-8364-9796	FAX: +86-20-8364-9707	<b>Boston</b>	TEL: +1-978-371-0382	FAX: +1-928-438-7164
<b>Shenzhen</b>	TEL: +86-755-8307-3001	FAX: +86-755-8307-3003	<b>Chicago</b>	TEL: +1-847-368-1006	FAX: +1-847-368-1008
<b>Xiamen</b>	TEL: +86-592-239-8382	FAX: +86-592-239-8380	<b>Dallas</b>	TEL: +1-972-312-8818	FAX: +1-972-312-0330
<b>Zhuhai</b>	TEL: +86-756-3232-480	FAX: +86-756-3232-460	<b>Denver</b>	TEL: +1-303-708-0908	FAX: +1-303-708-0858
<b>Taipei</b>	TEL: +886-2-2500-6956	FAX: +886-2-2503-2869	<b>Nashville</b>	TEL: +1-615-620-6700	FAX: +1-615-620-6702
<b>Kaohsiung</b>	TEL: +886-7-237-0881	FAX: +886-7-238-7332	<b>Guadalajara</b>	TEL: +52-33-3123-2001	FAX: +52-33-3123-2002
<b>Singapore</b>	TEL: +65-6332-2322	FAX: +65-6332-5662			
<b>Manila</b>	TEL: +63-2-807-6872	FAX: +63-2-809-1422			

### Notes

- No technical content pages of this document may be reproduced in any form or transmitted by any means without prior permission of ROHM CO.,LTD.
- The contents described herein are subject to change without notice. The specifications for the product described in this document are for reference only. Upon actual use, therefore, please request that specifications to be separately delivered.
- Application circuit diagrams and circuit constants contained herein are shown as examples of standard use and operation. Please pay careful attention to the peripheral conditions when designing circuits and deciding upon circuit constants in the set.
- Any data, including, but not limited to application circuit diagrams information, described herein are intended only as illustrations of such devices and not as the specifications for such devices. ROHM CO.,LTD. disclaims any warranty that any use of such devices shall be free from infringement of any third party's intellectual property rights or other proprietary rights, and further, assumes no liability of whatsoever nature in the event of any such infringement, or arising from or connected with or related to the use of such devices.
- Upon the sale of any such devices, other than for buyer's right to use such devices itself, resell or otherwise dispose of the same, no express or implied right or license to practice or commercially exploit any intellectual property rights or other proprietary rights owned or controlled by
- ROHM CO., LTD. is granted to any such buyer.
- Products listed in this document are no antiradiation design.

The products listed in this document are designed to be used with ordinary electronic equipment or devices (such as audio visual equipment, office-automation equipment, communications devices, electrical appliances and electronic toys).

Should you intend to use these products with equipment or devices which require an extremely high level of reliability and the malfunction of which would directly endanger human life (such as medical instruments, transportation equipment, aerospace machinery, nuclear-reactor controllers, fuel controllers and other safety devices), please be sure to consult with our sales representative in advance.

It is our top priority to supply products with the utmost quality and reliability. However, there is always a chance of failure due to unexpected factors. Therefore, please take into account the derating characteristics and allow for sufficient safety features, such as extra margin, anti-flammability, and fail-safe measures when designing in order to prevent possible accidents that may result in bodily harm or fire caused by component failure. ROHM cannot be held responsible for any damages arising from the use of the products under conditions out of the range of the specifications or due to non-compliance with the NOTES specified in this catalog.

Thank you for your accessing to ROHM product informations.

More detail product informations and catalogs are available, please contact your nearest sales office.

**ROHM** Customer Support System



THE AMERICAS / EUROPE / ASIA / JAPAN

[www.rohm.com](http://www.rohm.com)

Contact us : [webmaster@rohm.co.jp](mailto:webmaster@rohm.co.jp)

## Looking for pricing, stock, or lifecycle information?

Click below to explore more details on WIN SOURCE:

-  [View BA6427F-E2 on WIN SOURCE](#)
-  [Rohm Semiconductor](#) Information

## Optimize Your Supply Chain with WIN SOURCE Solutions

-  Global Sourcing Solution
-  Obsolete Management
-  Cost Control Management
-  Shortage Management
-  Alternative Solution
-  Excess Inventory Management