



# Motion SPM<sup>®</sup> 3 Series

## FNB33060T

FNB33060T is an advanced Motion SPM 3 module providing a fully-featured, high-performance inverter output stage for AC Induction, BLDC, and PMSM motors. These modules integrate optimized gate drive of the built-in IGBTs to minimize EMI and losses, while also providing multiple on-module protection features including under-voltage lockouts, over-current shutdown, thermal monitoring of drive IC, and fault reporting. The built-in, high-speed HVIC requires only a single supply voltage and translates the incoming logic-level gate inputs to the high-voltage, high-current drive signals required to properly drive the module's internal IGBTs. Separate negative IGBT terminals are available for each phase to support the widest variety of control algorithms.

### Features

- 600 V – 30 A 3-Phase IGBT Inverter with Integral Gate Drivers and Protection
- Low-Loss, Short-Circuit Rated IGBTs
- Very Low Thermal Resistance Using Al<sub>2</sub>O<sub>3</sub> DBC Substrate
- Built-In Bootstrap Diodes and Dedicated Vs Pins Simplify PCB Layout
- Separate Open-Emitter Pins from Low-Side IGBTs for Three-Phase Current Sensing
- Single-Grounded Power Supply
- LVIC Temperature-Sensing Built-In for Temperature Monitoring
- Isolation Rating: 2500 V<sub>rms</sub>/min
- This Device is Pb-Free and Halide Free

### Applications

- Motion Control – Home Appliance / Industrial Motor

### Integrated Power Functions

- 600 V – 30 A IGBT Inverter for Three-phase DC / AC Power Conversion (Please refer to Figure 2)

### Integrated Drive, Protection and System Control Functions

- For Inverter High-side IGBTs: gate drive circuit, high-voltage isolated high-speed level shifting control circuit Under-Voltage Lock-Out Protection (UVLO)  
(Note: Available bootstrap circuit example is given in Figures 5 and 15)
- For Inverter Low-side IGBTs: gate drive circuit, Short-Circuit Protection (SCP) control supply circuit Under-Voltage Lock-Out protection (UVLO)
- Fault Signaling: corresponding to UVLO (low-side supply) and SC faults
- Input Interface: Active-HIGH interface, works with 3.3 / 5 V logic, Schmitt-trigger input

3D Package Drawing  
 (Click to Activate 3D Content)

SPMCA-027 / PDD STD, SPM27-CA, DBC TYPE  
 CASE MODFJ

### MARKING DIAGRAM

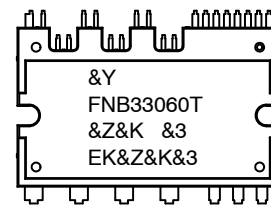

\$Y = onsemi Logo  
 &Z = Assembly Plant Code  
 &K = 2-Digits Lot Run Traceability Code  
 &3 = 3-Digit Date Code  
 FNB33060T = Specific Device Code

### ORDERING INFORMATION

See detailed ordering and shipping information on page 12 of this data sheet.

### Related Resources

- [AN-9088 – Motion SPM<sup>®</sup> 3 V6 Series Users Guide](#)
- [AN-9086 – SPM 3 Package Mounting Guide](#)

# FNB33060T

## PIN CONFIGURATION

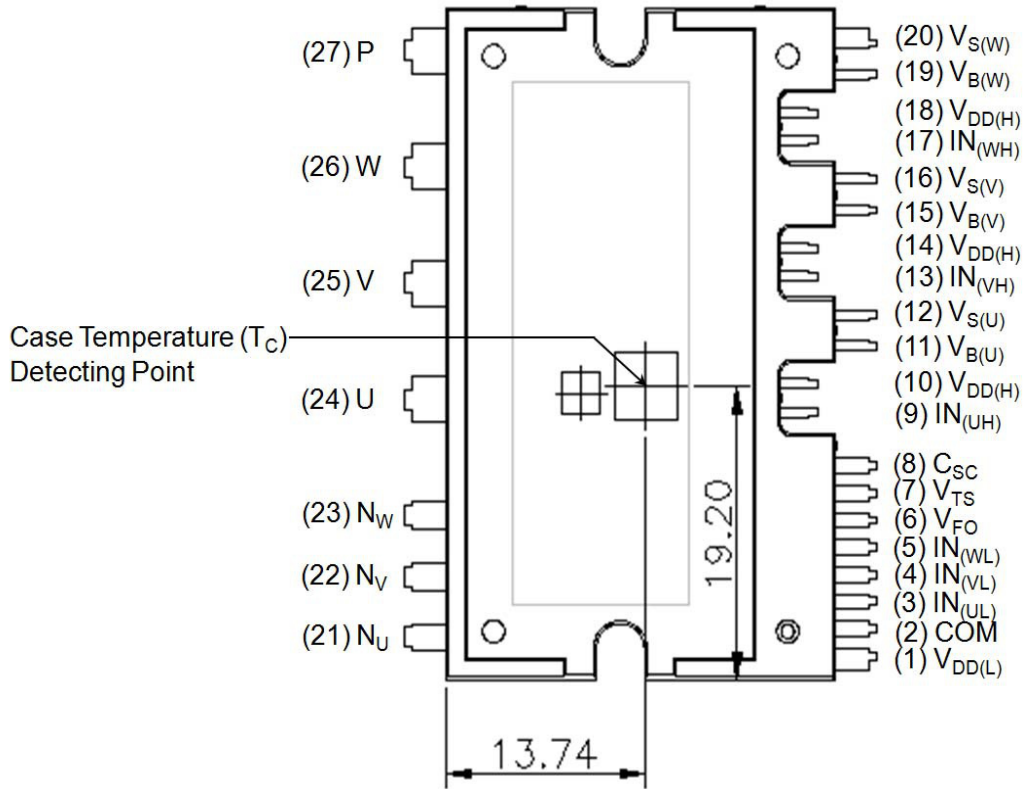

Figure 1. Pin Configuration – Top View

Table 1. PIN DESCRIPTIONS

Pin No.	Pin Name	Pin Description
1	$V_{DD(L)}$	Low-Side Common Bias Voltage for IC and IGBTs Driving
2	COM	Common Supply Ground
3	$IN_{(UL)}$	Signal Input for Low-Side U-Phase
4	$IN_{(VL)}$	Signal Input for Low-Side V-Phase
5	$IN_{(WL)}$	Signal Input for Low-Side W-Phase
6	$V_{FO}$	Fault Output
7	$V_{TS}$	Output for LVIC Temperature Sensing Voltage Output
8	$C_{SC}$	Shut Down Input for Short-Circuit Current Detection Input
9	$IN_{(UH)}$	Signal Input for High-Side U-Phase
10	$V_{DD(H)}$	High-Side Common Bias Voltage for IC and IGBTs Driving
11	$V_{B(U)}$	High-Side Bias Voltage for U-Phase IGBT Driving
12	$V_{S(U)}$	High-Side Bias Voltage Ground for U-Phase IGBT Driving
13	$IN_{(VH)}$	Signal Input for High-Side V-Phase
14	$V_{DD(H)}$	High-Side Common Bias Voltage for IC and IGBTs Driving
15	$V_{B(V)}$	High-Side Bias Voltage for V-Phase IGBT Driving
16	$V_{S(V)}$	High-Side Bias Voltage Ground for V Phase IGBT Driving
17	$IN_{(WH)}$	Signal Input for High-Side W-Phase

# FNB33060T

**Table 1. PIN DESCRIPTIONS** (continued)

Pin No.	Pin Name	Pin Description
18	$V_{DD(H)}$	High-Side Common Bias Voltage for IC and IGBTs Driving
19	$V_{B(W)}$	High-Side Bias Voltage for W-Phase IGBT Driving
20	$V_{S(W)}$	High-Side Bias Voltage Ground for W-Phase IGBT Driving
21	$N_U$	Negative DC-Link Input for U-Phase
22	$N_V$	Negative DC-Link Input for V-Phase
23	$N_W$	Negative DC-Link Input for W-Phase
24	U	Output for U-Phase
25	V	Output for V-Phase
26	W	Output for W-Phase
27	P	Positive DC-Link Input

## INTERNAL EQUIVALENT CIRCUIT AND INPUT/OUTPUT PINS

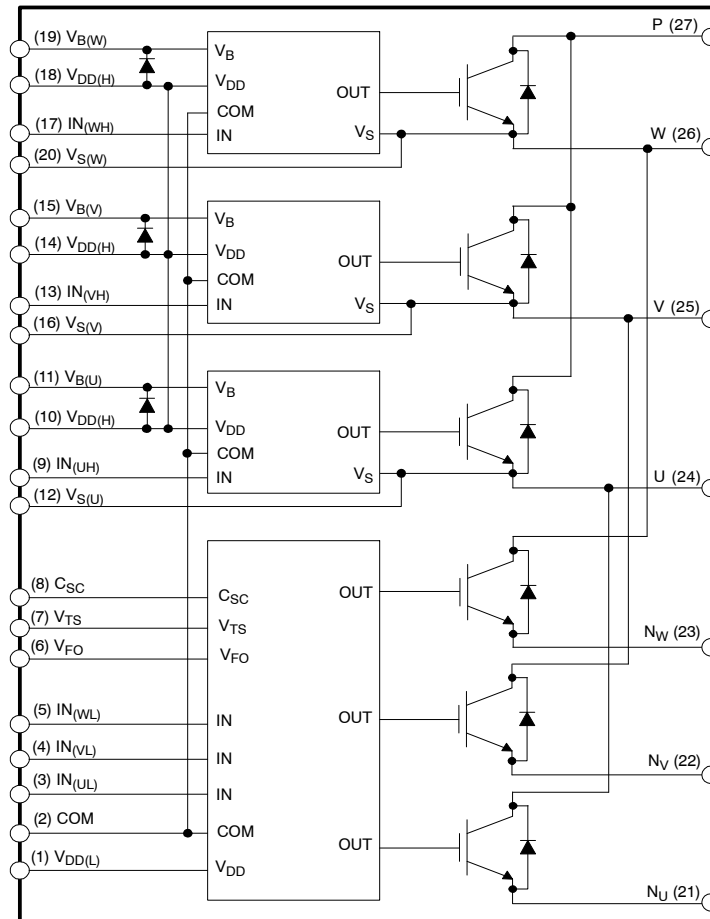

**Notes:**

1. Inverter low-side is composed of three IGBTs, freewheeling diodes for each IGBT, and one control IC. It has gate drive and protection functions.
2. Inverter power side is composed of four inverter DC-link input terminals and three inverter output terminals.
3. Inverter high-side is composed of three IGBTs, freewheeling diodes, and three drive ICs for each IGBT.

**Figure 2. Internal Block Diagram**

# FNB33060T

**Table 2. ABSOLUTE MAXIMUM RATINGS** ( $T_J = 25^\circ\text{C}$  unless otherwise specified)

Symbol	Parameter	Conditions	Rating	Unit
<b>INVERTER PART</b>				
$V_{PN}$	Supply Voltage	Applied between P – $N_U$ , $N_V$ , $N_W$	450	V
$V_{PN(\text{Surge})}$	Supply Voltage (Surge)	Applied between P – $N_U$ , $N_V$ , $N_W$	500	V
$V_{CES}$	Collector – Emitter Voltage		600	V
$\pm I_C$	Each IGBT Collector Current	$T_C = 25^\circ\text{C}$ , $T_J \leq 150^\circ\text{C}$ (Note 4)	30	A
$\pm I_{CP}$	Each IGBT Collector Current (Peak)	$T_C = 25^\circ\text{C}$ , $T_J \leq 150^\circ\text{C}$ , Under 1 ms Pulse Width (Note 4)	60	A
$P_C$	Collector Dissipation	$T_C = 25^\circ\text{C}$ per One Chip (Note 4)	89	W
$T_J$	Operating Junction Temperature		-40 ~ 150	$^\circ\text{C}$

**CONTROL PART**

$V_{DD}$	Control Supply Voltage	Applied between $V_{DD(H)}$ , $V_{DD(L)}$ – COM	20	V
$V_{BS}$	High-Side Control Bias Voltage	Applied between $V_{B(U)} - V_{S(U)}$ , $V_{B(V)} - V_{S(V)}$ , $V_{B(W)} - V_{S(W)}$	20	V
$V_{IN}$	Input Signal Voltage	Applied between $IN_{(UH)}$ , $IN_{(VH)}$ , $IN_{(WH)}$ , $IN_{(UL)}$ , $IN_{(VL)}$ , $IN_{(WL)}$ – COM	-0.3 ~ $V_{DD} + 0.3$	V
$V_{FO}$	Fault Output Supply Voltage	Applied between $V_{FO}$ – COM	-0.3 ~ $V_{DD} + 0.3$	V
$I_{FO}$	Fault Output Current	Sink Current at $V_{FO}$ pin	2	mA
$V_{SC}$	Current-Sensing Input Voltage	Applied between $C_{SC}$ – COM	-0.3 ~ $V_{DD} + 0.3$	V

**BOOTSTRAP DIODE PART**

$V_{RRM}$	Maximum Repetitive Reverse Voltage		600	V
$I_F$	Forward Current	$T_C = 25^\circ\text{C}$ , $T_J \leq 150^\circ\text{C}$ (Note 4)	0.5	A
$I_{FP}$	Forward Current (Peak)	$T_C = 25^\circ\text{C}$ , $T_J \leq 150^\circ\text{C}$ , Under 1 ms Pulse Width (Note 4)	2.0	A
$T_J$	Operating Junction Temperature		-40 ~ 150	$^\circ\text{C}$

**TOTAL SYSTEM**

$V_{PN(\text{PROT})}$	Self Protection Supply Voltage Limit (Short-Circuit Protection Capability)	$V_{DD} = V_{BS} = 13.5 \sim 16.5 \text{ V}$ , $T_J = 150^\circ\text{C}$ , Non-Replicative, < 2 $\mu\text{s}$	400	V
$T_C$	Module Case Operation Temperature	See Figure 1	-40 ~ 125	$^\circ\text{C}$
$T_{STG}$	Storage Temperature		-40 ~ 125	$^\circ\text{C}$
$V_{ISO}$	Isolation Voltage	60 Hz, Sinusoidal, AC 1 Minute, Connection Pins to Heat Sink Plate	2500	$V_{rms}$

Stresses exceeding those listed in the Maximum Ratings table may damage the device. If any of these limits are exceeded, device functionality should not be assumed, damage may occur and reliability may be affected.

4. These values had been made an acquisition by the calculation considered to design factor.

**Table 3. THERMAL RESISTANCE**

Symbol	Parameter	Conditions	Min	Typ	Max	Unit
$R_{th(j-c)Q}$	Junction to Case Thermal Resistance (Note 5)	Inverter IGBT part, (Per 1 / 6 Module)	-	-	1.4	$^\circ\text{C/W}$
$R_{th(j-c)F}$		Inverter FWDi part, (Per 1 / 6 Module)	-	-	2.4	$^\circ\text{C/W}$

5. For the measurement point of case temperature ( $T_C$ ), please refer to Figure 1.

# FNB33060T

**Table 4. ELECTRICAL CHARACTERISTICS** ( $T_J = 25^\circ\text{C}$  unless otherwise specified.)

Symbol	Parameter	Conditions	Min	Typ	Max	Unit	
<b>INVERTER PART</b>							
$V_{CE(SAT)}$	Collector – Emitter Saturation Voltage	$V_{DD} = V_{BS} = 15\text{ V}$ , $V_{IN} = 5\text{ V}$	$I_C = 30\text{ A}$ , $T_J = 25^\circ\text{C}$	–	1.6	2.2	V
$V_F$	FWDi Forward Voltage	$V_{IN} = 0\text{ V}$	$I_F = 30\text{ A}$ , $T_J = 25^\circ\text{C}$	–	2.0	2.6	V
HS	$t_{ON}$	Switching Times $V_{PN} = 300\text{ V}$ , $V_{DD} = 15\text{ V}$ , $I_C = 30\text{ A}$ , $T_J = 25^\circ\text{C}$ $V_{IN} = 0\text{ V} \leftrightarrow 5\text{ V}$ , Inductive load See Figure 4 (Note 6)		0.50	0.90	1.40	$\mu\text{s}$
	$t_{C(ON)}$			–	0.20	0.60	$\mu\text{s}$
	$t_{OFF}$			–	0.85	1.35	$\mu\text{s}$
	$t_{C(OFF)}$			–	0.15	0.45	$\mu\text{s}$
	$t_{rr}$			–	0.08	–	$\mu\text{s}$
LS	$t_{ON}$	$V_{PN} = 300\text{ V}$ , $V_{DD} = 15\text{ V}$ , $I_C = 30\text{ A}$ , $T_J = 25^\circ\text{C}$ $V_{IN} = 0\text{ V} \leftrightarrow 5\text{ V}$ , Inductive load See Figure 4 (Note 6)		0.40	0.80	1.30	$\mu\text{s}$
	$t_{C(ON)}$			–	0.25	0.60	$\mu\text{s}$
	$t_{OFF}$			–	0.90	1.40	$\mu\text{s}$
	$t_{C(OFF)}$			–	0.15	0.45	$\mu\text{s}$
	$t_{rr}$			–	0.10	–	$\mu\text{s}$
$I_{CES}$	Collector – Emitter Leakage Current	$V_{CE} = V_{CES}$		–	–	5	mA

Product parametric performance is indicated in the Electrical Characteristics for the listed test conditions, unless otherwise noted. Product performance may not be indicated by the Electrical Characteristics if operated under different conditions.

6.  $t_{ON}$  and  $t_{OFF}$  include the propagation delay time of the internal drive IC.  $t_{C(ON)}$  and  $t_{C(OFF)}$  are the switching times of IGBT itself under the given gate driving condition internally. For the detailed information, please see Figure 3.

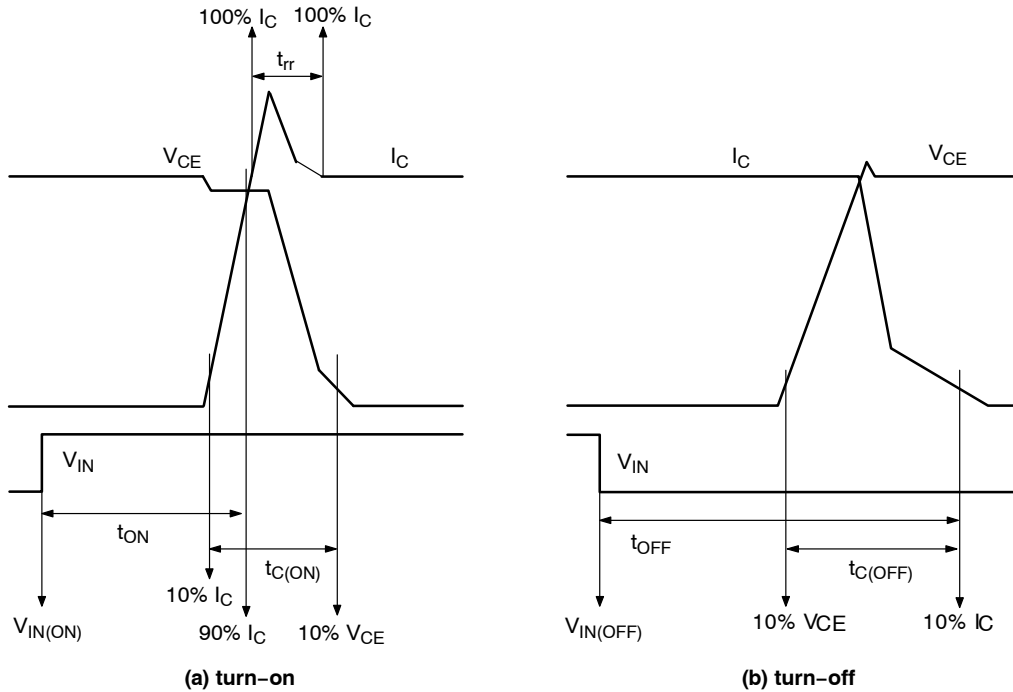

**Figure 3. Switching Time Definition**

# FNB33060T

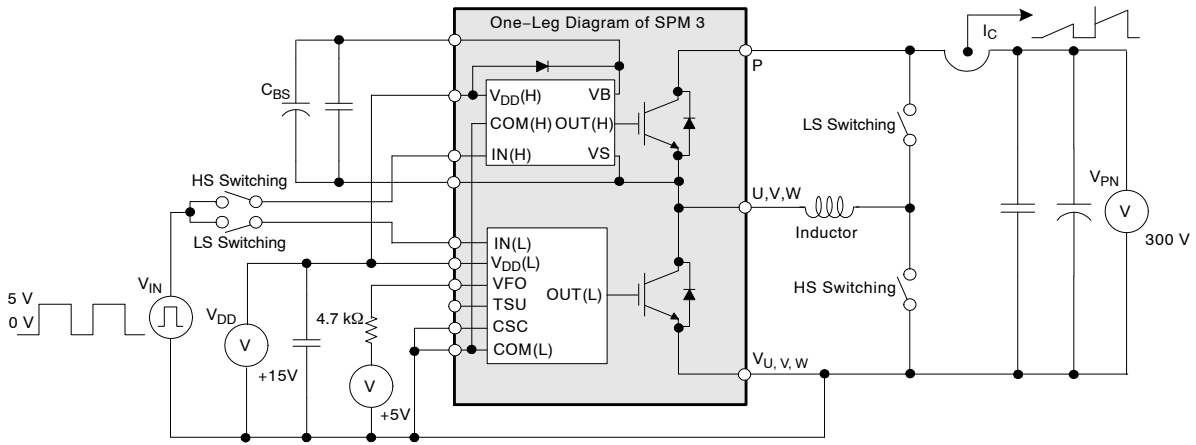

Figure 4. Example Circuit for Switching Test

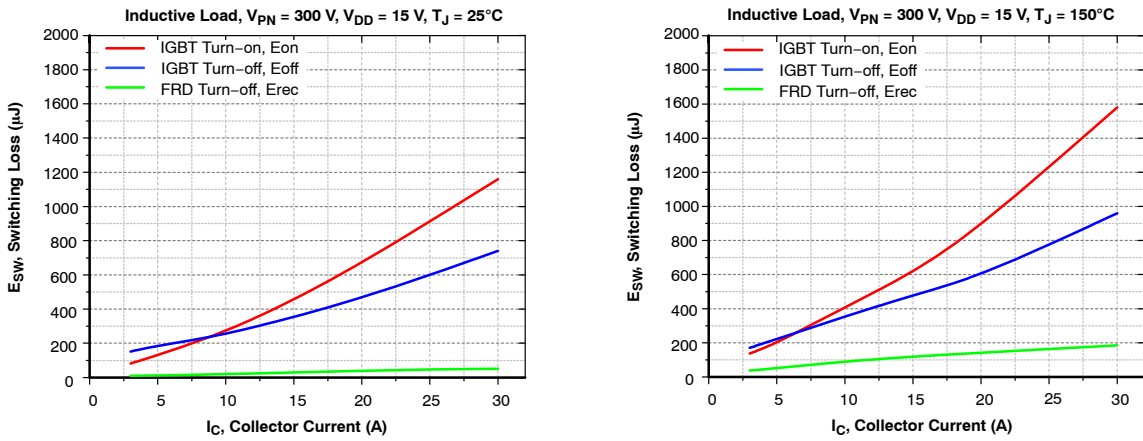

Figure 5. Switching Loss Characteristics

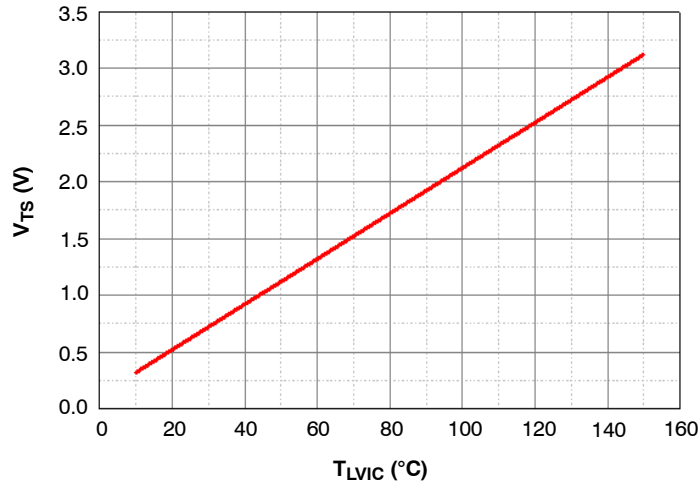

Figure 6. Temperature Profile of  $V_{TS}$  (Typical)

# FNB33060T

**Table 5. ELECTRICAL CHARACTERISTICS**

Symbol	Parameter	Conditions	Min	Typ	Max	Unit	
<b>BOOTSTRAP DIODE PART</b>							
$V_F$	Forward Voltage	$I_F = 0.1 \text{ A}$ , $T_J = 25^\circ\text{C}$	-	2.5	-	V	
$t_{rr}$	Reverse Recovery Time	$I_F = 0.1 \text{ A}$ , $dI_F / dt = 50 \text{ A}/\mu\text{s}$ , $T_J = 25^\circ\text{C}$	-	80	-	ns	
<b>CONTROL PART</b>							
$I_{QDDH}$	Quiescent $V_{DD}$ Supply Current	$V_{DD(H)} = 15 \text{ V}$ , $I_{N(UH, VH, WH)} = 0 \text{ V}$	$V_{DD(H)} - \text{COM}$	-	-	0.50	mA
$I_{QDDL}$		$V_{DD(L)} = 15 \text{ V}$ , $I_{N(UL, VL, WL)} = 0 \text{ V}$	$V_{DD(L)} - \text{COM}$	-	-	6.00	mA
$I_{PDH}$	Operating $V_{DD}$ Supply Current	$V_{DD(H)} = 15 \text{ V}$ , $f_{PWM} = 20 \text{ kHz}$ , duty = 50%, applied to one PWM signal input for High-Side	$V_{DD(H)} - \text{COM}$	-	-	0.50	mA
$I_{PDL}$		$V_{DD(L)} = 15 \text{ V}$ , $f_{PWM} = 20 \text{ kHz}$ , duty = 50%, applied to one PWM signal input for Low-Side	$V_{DD(L)} - \text{COM}$	-	-	10.0	mA
$I_{QBS}$	Quiescent $V_{BS}$ Supply Current	$V_{BS} = 15 \text{ V}$ , $I_{N(UH, VH, WH)} = 0 \text{ V}$	$V_{B(U)} - V_{S(U)}$ , $V_{B(V)} - V_{S(V)}$ , $V_{B(W)} - V_{S(W)}$	-	-	0.30	mA
$I_{PBS}$	Quiescent $V_{BS}$ Supply Current	$V_{DD} = V_{BS} = 15 \text{ V}$ , $f_{PWM} = 20 \text{ kHz}$ , duty = 50%, applied to one PWM signal input for High-Side	$V_{B(U)} - V_{S(U)}$ , $V_{B(V)} - V_{S(V)}$ , $V_{B(W)} - V_{S(W)}$	-	-	4.50	mA
$V_{FOH}$	Fault Output Voltage	$V_{DD} = 15 \text{ V}$ , $V_{SC} = 0 \text{ V}$ , $V_{FO}$ Circuit: 4.7 k $\Omega$ to 5 V Pull-up	4.5	-	-	V	
$V_{FOL}$		$V_{DD} = 15 \text{ V}$ , $V_{SC} = 1 \text{ V}$ , $V_{FO}$ Circuit: 4.7 k $\Omega$ to 5 V Pull-up	-	-	0.5	V	
$V_{SC(ref)}$	Short Circuit Trip Level	$V_{DD} = 15 \text{ V}$ (Note 7)	$C_{SC} - \text{COM}$	0.45	0.50	0.55	V
$UV_{DDD}$	Supply Circuit Under-Voltage Protection	Detection level		9.8	-	13.3	V
$UV_{DDR}$		Reset level		10.3	-	13.8	V
$UV_{BSD}$		Detection level		9.0	-	12.5	V
$UV_{BSR}$		Reset level		9.5	-	13.0	V
$t_{FOD}$	Fault-Out Pulse Width		50	-	-	$\mu\text{s}$	
$V_{TS}$	LVIC Temperature Sensing Voltage Output	$V_{DD(L)} = 15 \text{ V}$ , $T_{LVIC} = 25^\circ\text{C}$ (Note 8) See Figure 6	540	640	740	mV	
$V_{IN(ON)}$	ON Threshold Voltage	Applied between $I_{N(UH, VH, WH)} - \text{COM}$ , $I_{N(UL, VL, WL)} - \text{COM}$	-	-	2.6	V	
$V_{IN(OFF)}$	OFF Threshold Voltage		0.8	-	-	V	

Product parametric performance is indicated in the Electrical Characteristics for the listed test conditions, unless otherwise noted. Product performance may not be indicated by the Electrical Characteristics if operated under different conditions.

7. Short-circuit current protection functioning only at the low-sides.

8.  $T_{LVIC}$  is the temperature of LVIC itself.  $V_{TS}$  is only for sensing temperature of LVIC and can not shutdown IGBTs automatically.

# FNB33060T

**Table 6. RECOMMENDED OPERATING CONDITIONS**

Symbol	Parameter	Conditions	Min	Typ	Max	Unit
$V_{PN}$	Supply Voltage	Applied between P – N <sub>U</sub> , N <sub>V</sub> , N <sub>W</sub>	–	300	400	V
$V_{DD}$	Control Supply Voltage	Applied between V <sub>DD(H)</sub> , V <sub>DD(L)</sub> – COM	14.0	15	16.5	V
$V_{BS}$	High – Side Bias Voltage	Applied between V <sub>B(U)</sub> – V <sub>S(U)</sub> , V <sub>B(V)</sub> – V <sub>S(V)</sub> , V <sub>B(W)</sub> – V <sub>S(W)</sub>	13.0	15	18.5	V
$dV_{DD}/dt$ , $dV_{BS}/dt$	Control Supply Variation		–1	–	1	V/ $\mu$ s
$t_{dead}$	Blanking Time for Preventing Arm – Short	For each input signal	1.0	–	–	$\mu$ s
$f_{PWM}$	PWM Input Signal	$-40^{\circ}\text{C} \leq T_C \leq 125^{\circ}\text{C}$ , $-40^{\circ}\text{C} \leq T_J \leq 150^{\circ}\text{C}$	–	–	20	kHz
$V_{SEN}$	Voltage for Current Sensing	Applied between N <sub>U</sub> , N <sub>V</sub> , N <sub>W</sub> – COM (Including Surge Voltage)	–5	–	5	V
$PW_{IN(ON)}$	Minimum Input Pulse Width	$V_{DD} = V_{BS} = 15\text{ V}$ , $I_C \leq 60\text{ A}$ , Wiring Inductance between N <sub>U</sub> , v, w and DC Link N < 10 nH (Note 9)	2.0	–	–	$\mu$ s
$PW_{IN(OFF)}$			2.0	–	–	
$T_J$	Junction Temperature		–40	–	150	$^{\circ}\text{C}$

Functional operation above the stresses listed in the Recommended Operating Ranges is not implied. Extended exposure to stresses beyond the Recommended Operating Ranges limits may affect device reliability.

9. This product might not make response if input pulse width is less than the recommended value.

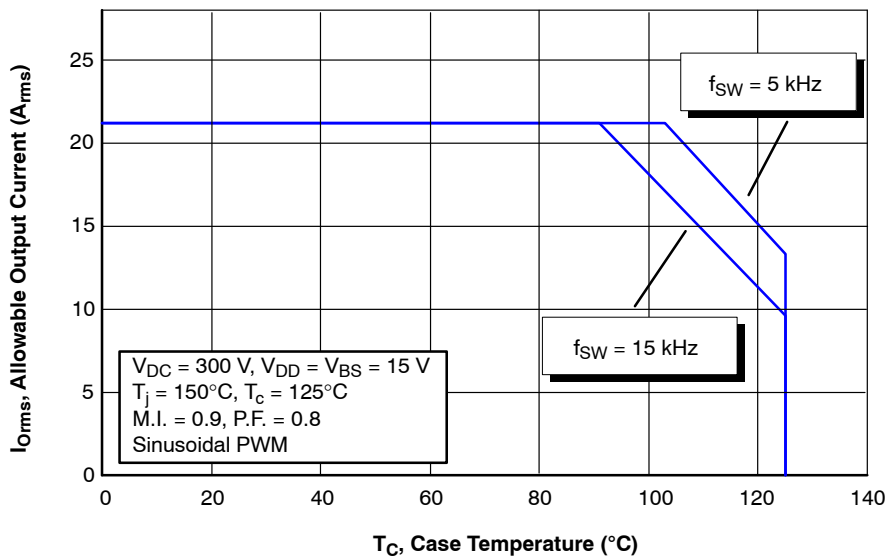

**Figure 7. Allowable Maximum Output Current**

NOTE:

10. This allowable output current value is the reference data for the safe operation of this product. This may be different from the actual application and operating condition.

# FNB33060T

**Table 7. MECHANICAL CHARACTERISTICS AND RATINGS**

Parameter	Conditions	Min	Typ	Max	Unit	
Device Flatness	See Figure 8	0	-	+150	$\mu\text{m}$	
Mounting Torque	Mounting Screw: M3 See Figure 9	Recommended 0.7 N • m	0.6	0.7	0.8	N • m
		Recommended 7.1 kg • cm	6.2	7.1	8.1	kg • cm
Terminal Pulling Strength	Load 19.6 N	10	-	-	s	
Terminal Bending Strength	Load 9.8 N, 90 deg. bend	2	-	-	times	
Weight		-	15	-	g	

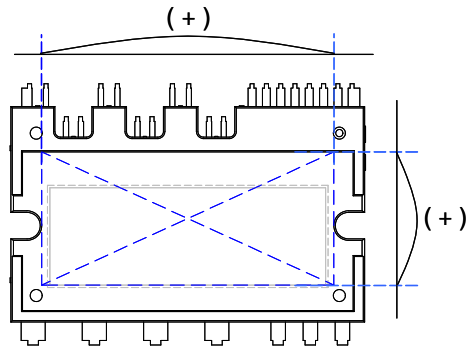

**Figure 8. Flatness Measurement Position**

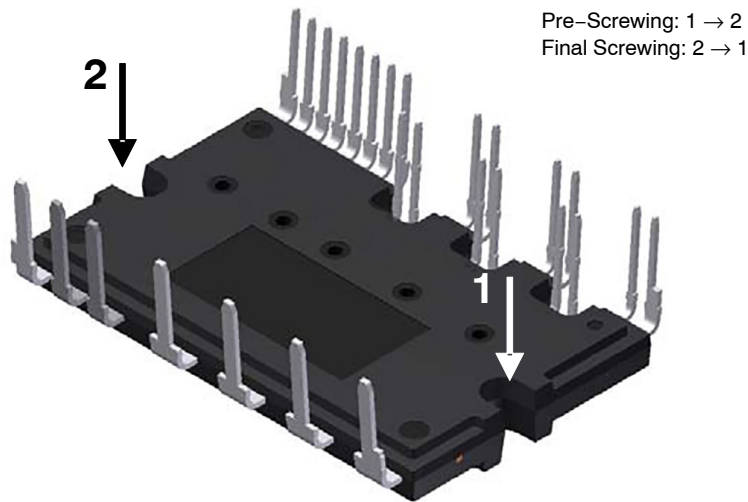

**NOTES:**

- 11. Do not make over torque when mounting screws. Much mounting torque may cause DBC cracks, as well as bolts and Al heat-sink destruction.
- 12. Avoid one-sided tightening stress. Figure 9 shows the recommended torque order for mounting screws. Uneven mounting can cause the DBC substrate of package to be damaged. The pre-screwing torque is set to 20 ~ 30% of maximum torque rating.

**Figure 9. Mounting Screws Torque Order**

TIME CHARTS OF SPMS PROTECTIVE FUNCTION

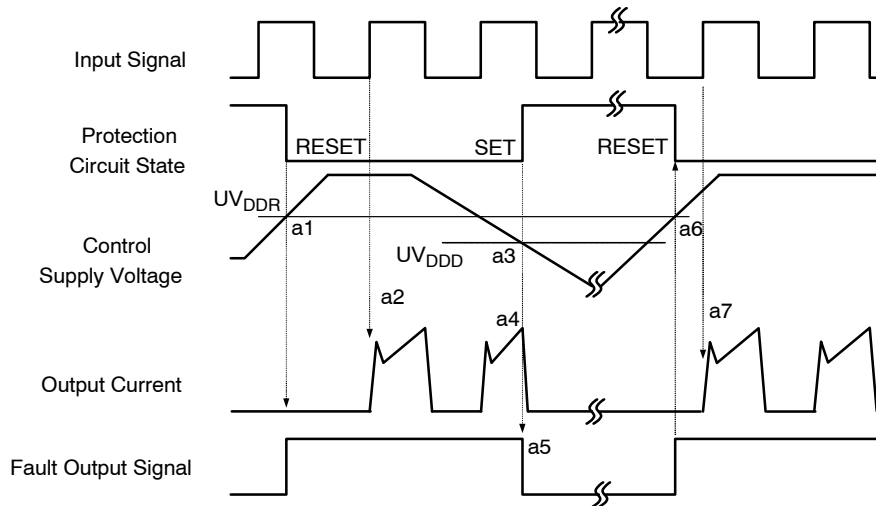

- a1: Control supply voltage rises: after the voltage rises  $UV_{DDR}$ , the circuits start to operate when next input is applied.
- a2: Normal operation: IGBT ON and carrying current.
- a3: Under-voltage detection ( $UV_{DDD}$ ).
- a4: IGBT OFF in spite of control input condition.
- a5: Fault output operation starts with a fixed pulse width.
- a6: Under-voltage reset ( $UV_{DDR}$ ).
- a7: Normal operation: IGBT ON and carrying current by triggering next signal from LOW to HIGH.

Figure 10. Under-Voltage Protection (Low-Side)

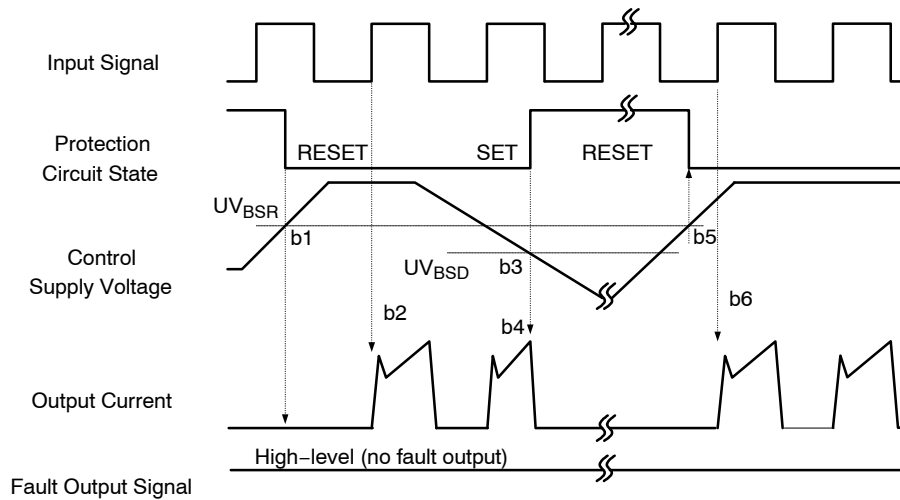

- b1: Control supply voltage rises: after the voltage reaches  $UV_{BSR}$ , the circuits start to operate when next input is applied.
- b2: Normal operation: IGBT ON and carrying current.
- b3: Under voltage detection ( $UV_{BSD}$ ).
- b4: IGBT OFF in spite of control input condition, but there is no fault output signal.
- b5: Under-voltage reset ( $UV_{BSR}$ ).
- b6: Normal operation: IGBT ON and carrying current by triggering next signal from LOW to HIGH.

Figure 11. Under-Voltage Protection (High-Side)

## FNB33060T

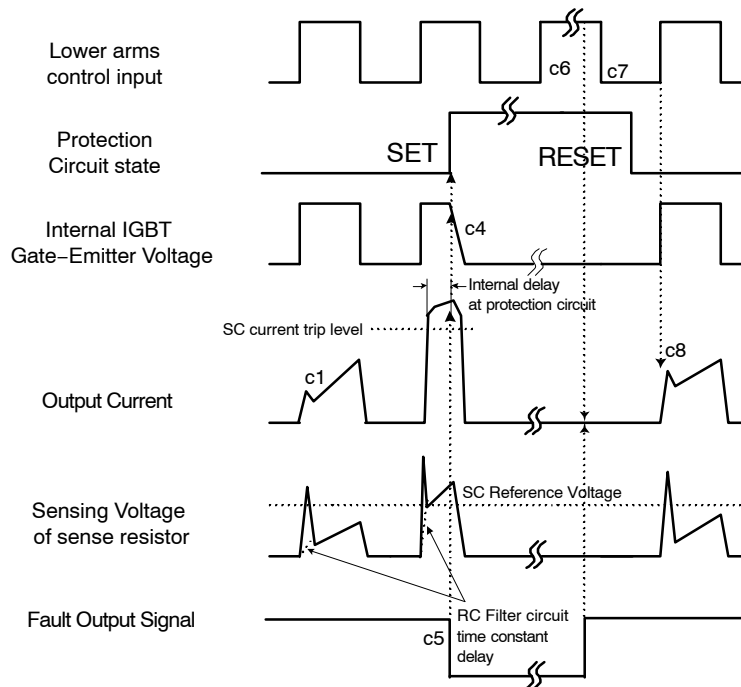

(with the external sense resistance and RC filter connection)

c1: Normal operation: IGBT ON and carrying current.

c2: Short circuit current detection (SC trigger).

c3: All low-side IGBT's gate are hard interrupted.

c4: All low-side IGBTs turn OFF.

c5: Fault output operation starts with a fixed pulse width.

c6: Input HIGH: IGBT ON state, but during the active period of fault output the IGBT doesn't turn ON.

c7: Fault output operation finishes, but IGBT doesn't turn on until triggering next signal from LOW to HIGH.

c8: Normal operation: IGBT ON and carrying current.

**Figure 12. Short-Circuit Protection (Low-Side Operation Only)**

## INPUT/OUTPUT INTERFACE CIRCUIT

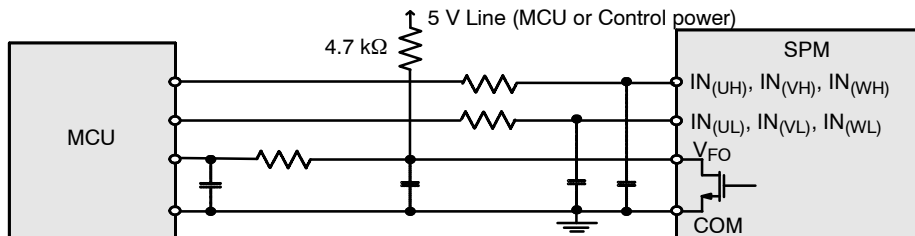

NOTE:

13. RC coupling at each input might change depending on the PWM control scheme used in the application and the wiring impedance of the application's printed circuit board. The input signal section of the Motion SPM 3 product integrates 5 kΩ (typ.) pull-down resistor. Therefore, when using an external filtering resistor, please pay attention to the signal voltage drop at input terminal.

**Figure 13. Recommended MCU I/O Interface Circuit**

# FNB33060T

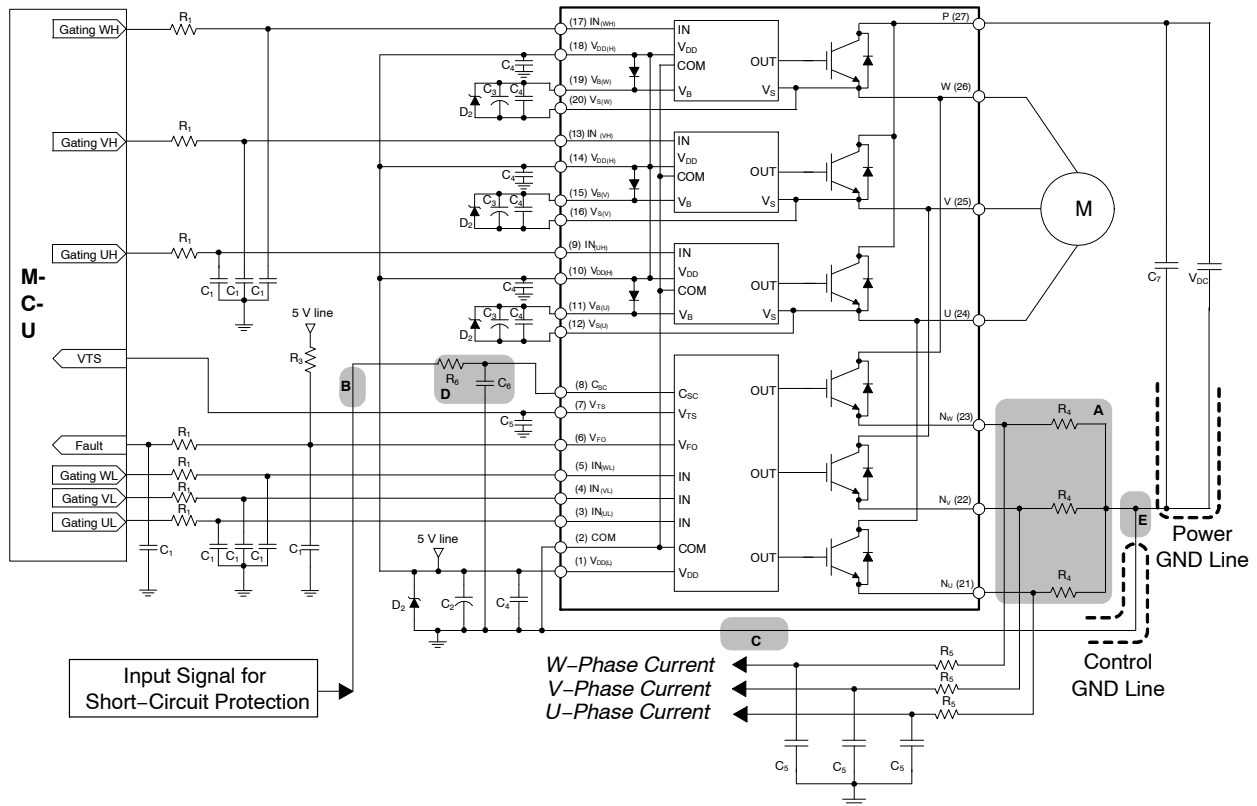

**Figure 14. Typical Application Circuit**

**NOTES:**

14. To avoid malfunction, the wiring of each input should be as short as possible (less than 2 – 3 cm).
15.  $V_{FO}$  output is open-drain type. This signal line should be pulled up to the positive side of the MCU or control power supply with a resistor that makes  $I_{FO}$  up to 2 mA. Please refer to Figure 13.
16. Input signal is active-HIGH type. There is a 5 k $\Omega$  resistor inside the IC to pull-down each input signal line to GND. RC coupling circuits should be adopted for the prevention of input signal oscillation.  $R_1C_1$  time constant should be selected in the range 50 ~ 150 ns. (Recommended  $R_1 = 100 \Omega$ ,  $C_1 = 1 \text{ nF}$ ).
17. Each wiring pattern inductance of A point should be minimized (Recommend less than 10 nH). Use the shunt resistor  $R_4$  of surface mounted (SMD) type to reduce wiring inductance. To prevent malfunction, wiring of point E should be connected to the terminal of the shunt resistor  $R_4$  as close as possible.
18. To prevent errors of the protection function, the wiring of B, C, and D point should be as short as possible.
19. In the short-circuit protection circuit, please select the  $R_6C_6$  time constant in the range 1.5 ~ 2  $\mu\text{s}$ . Do enough evaluation on the real system because short-circuit protection time may vary wiring pattern layout and value of the  $R_6C_6$  time constant.
20. Each capacitor should be mounted as close to the pins of the Motion SPM<sup>®</sup> 3 product as possible.
21. To prevent surge destruction, the wiring between the smoothing capacitor  $C_7$  and the P & GND pins should be as short as possible. The use of a high-frequency non-inductive capacitor of around 0.1 ~ 0.22  $\mu\text{F}$  between the P & GND pins is recommended.
22. Relays are used at almost every systems of electrical equipments at industrial application. In these cases, there should be sufficient distance between the CPU and the relays.
23. The zener diode or transient voltage suppressor should be adopted for the protection of ICs from the surge destruction between each pair of control supply terminals (Recommended zener diode is 22 V / 1 W, which has the lower zener impedance characteristic than about 15  $\Omega$ ).
24.  $C_2$  of around 7 times larger than bootstrap capacitor  $C_3$  is recommended.
25. Please choose the electrolytic capacitor with good temperature characteristic in  $C_3$ . Also, choose 0.1 ~ 0.2  $\mu\text{F}$  R-category ceramic capacitors with good temperature and frequency characteristics in  $C_4$ .

**PACKAGE MARKING AND ORDERING INFORMATION**

Device	Device Marking	Package	Shipping
FNB33060T	FNB33060T	SPMCA-027 / PDD STD, SPM27-CA, DBC TYPE (Pb-Free / Halide Free)	60 Units / Tube

SPM is a registered trademark of Semiconductor Components Industries, LLC dba "onsemi" or its affiliates and/or subsidiaries in the United States and/or other countries.

# MECHANICAL CASE OUTLINE

## PACKAGE DIMENSIONS

ON Semiconductor®



### SPMCA-027 / PDD STD, SPM27-CA, DBC TYPE

#### CASE MODFJ

#### ISSUE O

DATE 31 JAN 2017

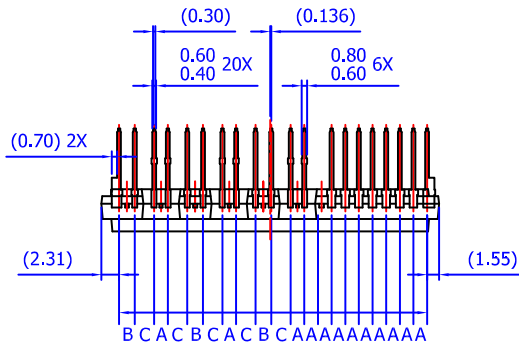

LEAD PITCH (TOLERANCE : ±0.30)

- A : 1.778
- B : 2.050
- C : 2.531

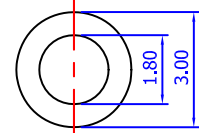
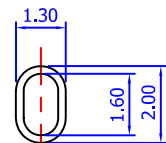
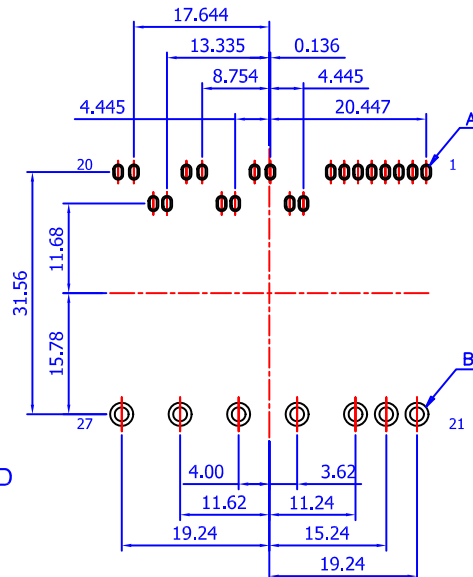
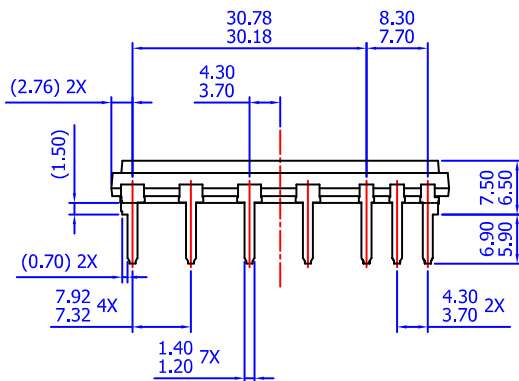
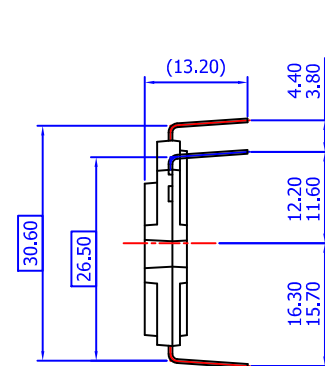
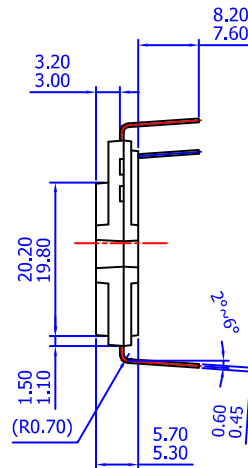
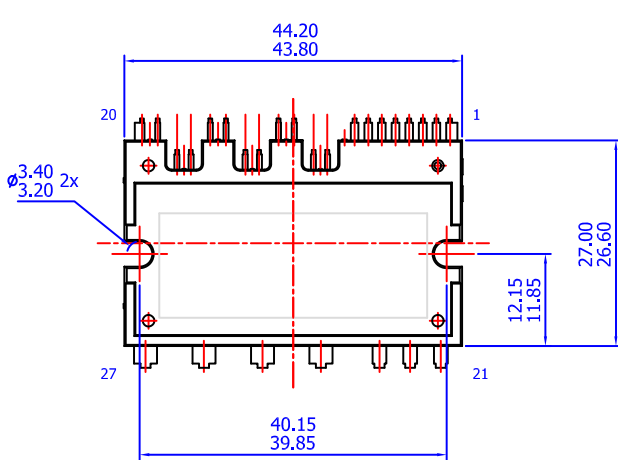

- NOTES: UNLESS OTHERWISE SPECIFIED
- A) THIS PACKAGE DOES NOT COMPLY TO ANY CURRENT PACKAGING STANDARD
  - B) ALL DIMENSIONS ARE IN MILLIMETERS
  - C) DIMENSIONS ARE EXCLUSIVE OF BURRS, MOLD FLASH, AND TIE BAR EXTRUSIONS
  - D) ( ) IS REFERENCE

### LAND PATTERN RECOMMENDATIONS

<b>DOCUMENT NUMBER:</b>	<b>98AON13563G</b>	Electronic versions are uncontrolled except when accessed directly from the Document Repository. Printed versions are uncontrolled except when stamped "CONTROLLED COPY" in red.
<b>DESCRIPTION:</b>	<b>SPMCA-027 / PDD STD, SPM27-CA, DBC TYPE</b>	<b>PAGE 1 OF 1</b>

ON Semiconductor and ON are trademarks of Semiconductor Components Industries, LLC dba ON Semiconductor or its subsidiaries in the United States and/or other countries. ON Semiconductor reserves the right to make changes without further notice to any products herein. ON Semiconductor makes no warranty, representation or guarantee regarding the suitability of its products for any particular purpose, nor does ON Semiconductor assume any liability arising out of the application or use of any product or circuit, and specifically disclaims any and all liability, including without limitation special, consequential or incidental damages. ON Semiconductor does not convey any license under its patent rights nor the rights of others.

**onsemi**, **Onsemi**, and other names, marks, and brands are registered and/or common law trademarks of Semiconductor Components Industries, LLC dba "**onsemi**" or its affiliates and/or subsidiaries in the United States and/or other countries. **onsemi** owns the rights to a number of patents, trademarks, copyrights, trade secrets, and other intellectual property. A listing of **onsemi**'s product/patent coverage may be accessed at [www.onsemi.com/site/pdf/Patent-Marking.pdf](http://www.onsemi.com/site/pdf/Patent-Marking.pdf). **onsemi** reserves the right to make changes at any time to any products or information herein, without notice. The information herein is provided "as-is" and **onsemi** makes no warranty, representation or guarantee regarding the accuracy of the information, product features, availability, functionality, or suitability of its products for any particular purpose, nor does **onsemi** assume any liability arising out of the application or use of any product or circuit, and specifically disclaims any and all liability, including without limitation special, consequential or incidental damages. Buyer is responsible for its products and applications using **onsemi** products, including compliance with all laws, regulations and safety requirements or standards, regardless of any support or applications information provided by **onsemi**. "Typical" parameters which may be provided in **onsemi** data sheets and/or specifications can and do vary in different applications and actual performance may vary over time. All operating parameters, including "Typicals" must be validated for each customer application by customer's technical experts. **onsemi** does not convey any license under any of its intellectual property rights nor the rights of others. **onsemi** products are not designed, intended, or authorized for use as a critical component in life support systems or any FDA Class 3 medical devices or medical devices with a same or similar classification in a foreign jurisdiction or any devices intended for implantation in the human body. Should Buyer purchase or use **onsemi** products for any such unintended or unauthorized application, Buyer shall indemnify and hold **onsemi** and its officers, employees, subsidiaries, affiliates, and distributors harmless against all claims, costs, damages, and expenses, and reasonable attorney fees arising out of, directly or indirectly, any claim of personal injury or death associated with such unintended or unauthorized use, even if such claim alleges that **onsemi** was negligent regarding the design or manufacture of the part. **onsemi** is an Equal Opportunity/Affirmative Action Employer. This literature is subject to all applicable copyright laws and is not for resale in any manner.

## ADDITIONAL INFORMATION

### TECHNICAL PUBLICATIONS:

Technical Library: [www.onsemi.com/design/resources/technical-documentation](http://www.onsemi.com/design/resources/technical-documentation)  
onsemi Website: [www.onsemi.com](http://www.onsemi.com)

### ONLINE SUPPORT: [www.onsemi.com/support](http://www.onsemi.com/support)

For additional information, please contact your local Sales Representative at [www.onsemi.com/support/sales](http://www.onsemi.com/support/sales)

## Looking for pricing, stock, or lifecycle information?

Click below to explore more details on WIN SOURCE:

- ⊖ [View FNB33060T](#) on WIN SOURCE
- ⊖ [ON Semiconductor](#) Information

## Optimize Your Supply Chain with WIN SOURCE Solutions

- ✓ Global Sourcing Solution
- ✓ Obsolete Management
- ✓ Cost Control Management
- ✓ Shortage Management
- ✓ Alternative Solution
- ✓ Excess Inventory Management