



**THE DATASHEET OF  
EP4CE55F23C8**





## Introduction

## Preliminary Information

The Cyclone™ field programmable gate array family is based on a 1.5-V, 0.13- $\mu$ m, all-layer copper SRAM process, with densities up to 20,060 logic elements (LEs) and up to 288 Kbits of RAM. With features like phase-locked loops (PLLs) for clocking and a dedicated double data rate (DDR) interface to meet DDR SDRAM and fast cycle RAM (FCRAM) memory requirements, Cyclone devices are a cost-effective solution for data-path applications. Cyclone devices support various I/O standards, including LVDS at data rates up to 311 megabits per second (Mbps) and 66-MHz, 32-bit peripheral component interconnect (PCI), for interfacing with and supporting ASSP and ASIC devices. Altera also offers new low-cost serial configuration devices to configure Cyclone devices.

## Features...

- 2,910 to 20,060 LEs, see [Table 1](#)
- Up to 294,912 RAM bits (36,864 bytes)
- Supports configuration through low-cost serial configuration device
- Support for LVTTTL, LVCMOS, SSTL-2, and SSTL-3 I/O standards
- Support for 66-MHz, 32-bit PCI standard
- Low speed (311 Mbps) LVDS I/O support
- Up to two PLLs per device provide clock multiplication and phase shifting
- Up to eight global clock lines with six clock resources available per logic array block (LAB) row
- Support for external memory, including DDR SDRAM (133 MHz), FCRAM, and single data rate (SDR) SDRAM
- Support for multiple intellectual property (IP) cores, including Altera® MegaCore® functions and Altera Megafunctions Partners Program (AMPP<sup>SM</sup>) megafunctions

**Table 1. Cyclone Device Features**

Feature	EP1C3	EP1C4	EP1C6	EP1C12	EP1C20
LEs	2,910	4,000	5,980	12,060	20,060
M4K RAM blocks (128 × 36 bits)	13	17	20	52	64
Total RAM bits	59,904	78,336	92,160	239,616	294,912
PLLs	1	2	2	2	2
Maximum user I/O pins (1)	104	301	185	249	301

Note to [Table 1](#):

(1) This parameter includes global clock pins.

Cyclone devices are available in quad flat pack (QFP) and space-saving FineLine BGA® packages (see [Tables 2](#) through [3](#)).

Device	100-Pin TQFP (1)	144-Pin TQFP (1), (2)	240-Pin PQFP (1)	256-Pin FineLine BGA	324-Pin FineLine BGA	400-Pin FineLine BGA
EP1C3	65	104				
EP1C4					249	301
EP1C6		98	185	185		
EP1C12			173	185	249	
EP1C20					233	301

**Notes to Table 2:**

- (1) TQFP: thin quad flat pack.  
PQFP: plastic quad flat pack.
- (2) Cyclone devices support vertical migration within the same package (i.e., designers can migrate between the EP1C3 device in the 144-pin TQFP package and the EP1C6 device in the same package).

Dimension	100-Pin TQFP	144-Pin TQFP	240-Pin PQFP	256-Pin FineLine BGA	324-Pin FineLine BGA	400-Pin FineLine BGA
Pitch (mm)	0.5	0.5	0.5	1.0	1.0	1.0
Area (mm <sup>2</sup> )	256	484	1,024	289	361	441
Length × width (mm × mm)	16 × 16	22 × 22	34.6 × 34.6	17 × 17	19 × 19	21 × 21

**Table of Contents**

Introduction .....	1
Features .....	1
Table of Contents .....	3
Functional Description .....	4
Logic Array Blocks .....	6
Logic Elements .....	9
MultiTrack Interconnect .....	17
Embedded Memory .....	23
Global Clock Network & Phase-Locked Loops .....	34
I/O Structure .....	44
Power Sequencing & Hot Socketing .....	60
IEEE Std. 1149.1 (JTAG) Boundary Scan Support .....	60
SignalTap II Embedded Logic Analyzer .....	65
Configuration .....	65
Operating Conditions .....	67
Power Consumption .....	73
Timing Model .....	74
Software .....	94
Device Pin-Outs .....	94
Ordering Information .....	94

## Functional Description

Cyclone devices contain a two-dimensional row- and column-based architecture to implement custom logic. Column and row interconnects of varying speeds provide signal interconnects between LABs and embedded memory blocks.

The logic array consists of LABs, with 10 LEs in each LAB. An LE is a small unit of logic providing efficient implementation of user logic functions. LABs are grouped into rows and columns across the device. Cyclone devices range between 2,910 to 20,060 LEs.

M4K RAM blocks are true dual-port memory blocks with 4K bits of memory plus parity (4,608 bits). These blocks provide dedicated true dual-port, simple dual-port, or single-port memory up to 36-bits wide at up to 200 MHz. These blocks are grouped into columns across the device in between certain LABs. Cyclone devices offer between 60 to 288 Kbits of embedded RAM.

Each Cyclone device I/O pin is fed by an I/O element (IOE) located at the ends of LAB rows and columns around the periphery of the device. I/O pins support various single-ended and differential I/O standards, such as the 66-MHz, 32-bit PCI standard and the LVDS I/O standard at up to 311 Mbps. Each IOE contains a bidirectional I/O buffer and three registers for registering input, output, and output-enable signals. Dual-purpose DQS, DQ, and DM pins along with delay chains (used to phase-align DDR signals) provide interface support with external memory devices such as DDR SDRAM, and FCRAM devices at up to 133 MHz (266 Mbps).

Cyclone devices provide a global clock network and up to two PLLs. The global clock network consists of eight global clock lines that drive throughout the entire device. The global clock network can provide clocks for all resources within the device, such as IOEs, LEs, and memory blocks. The global clock lines can also be used for control signals. Cyclone PLLs provide general-purpose clocking with clock multiplication and phase shifting as well as external outputs for high-speed differential I/O support.

Figure 1 shows a diagram of the Cyclone EP1C12 device.

**Figure 1. Cyclone EP1C12 Device Block Diagram**

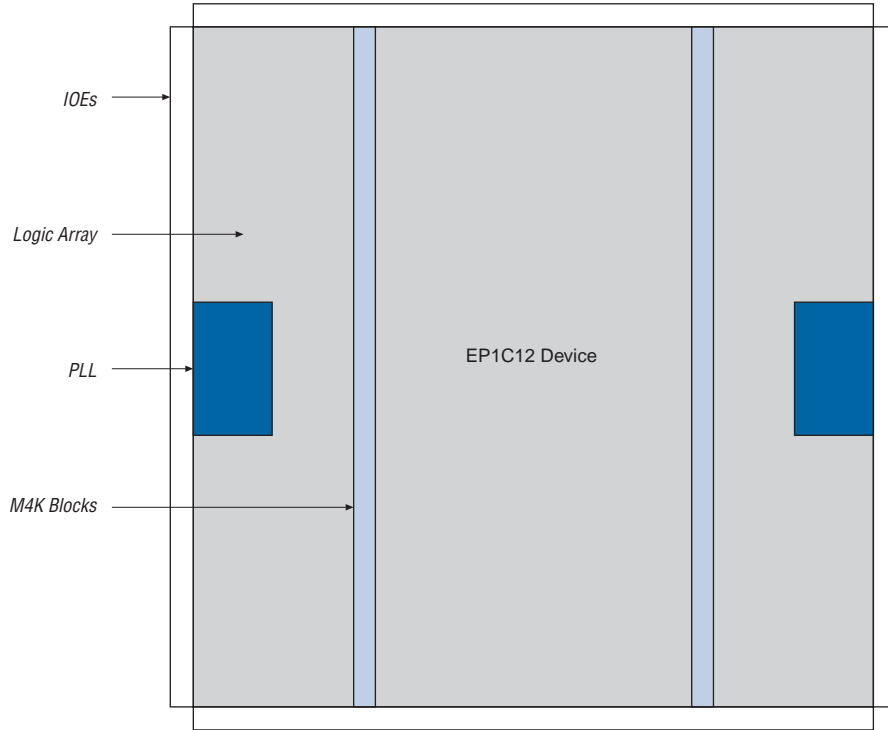

The number of M4K RAM blocks, PLLs, rows, and columns vary per device. [Table 4](#) lists the resources available in each Cyclone device.

<b>Table 4. Cyclone Device Resources</b>					
<b>Device</b>	<b>M4K RAM</b>		<b>PLLs</b>	<b>LAB Columns</b>	<b>LAB Rows</b>
	<b>Columns</b>	<b>Blocks</b>			
EP1C3	1	13	1	24	13
EP1C4	1	17	2	26	17
EP1C6	1	20	2	32	20
EP1C12	2	52	2	48	26
EP1C20	2	64	2	64	32

## Logic Array Blocks

Each LAB consists of 10 LEs, LE carry chains, LAB control signals, a local interconnect, look-up table (LUT) chain, and register chain connection lines. The local interconnect transfers signals between LEs in the same LAB. LUT chain connections transfer the output of one LE's LUT to the adjacent LE for fast sequential LUT connections within the same LAB. Register chain connections transfer the output of one LE's register to the adjacent LE's register within an LAB. The Quartus® II Compiler places associated logic within an LAB or adjacent LABs, allowing the use of local, LUT chain, and register chain connections for performance and area efficiency. Figure 2 details the Cyclone LAB.

**Figure 2. Cyclone LAB Structure**

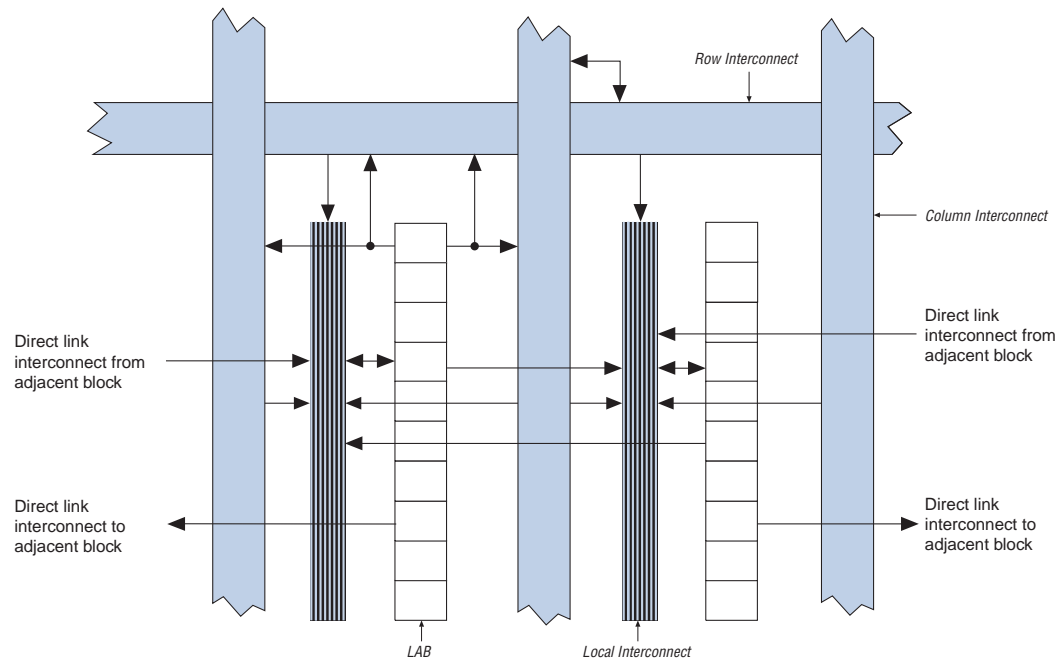

## LAB Interconnects

The LAB local interconnect can drive LEs within the same LAB. The LAB local interconnect is driven by column and row interconnects and LE outputs within the same LAB. Neighboring LABs, PLLs, and M4K RAM blocks from the left and right can also drive an LAB's local interconnect through the direct link connection. The direct link connection feature minimizes the use of row and column interconnects, providing higher performance and flexibility. Each LE can drive 30 other LEs through fast local and direct link interconnects. [Figure 3](#) shows the direct link connection.

**Figure 3. Direct Link Connection**

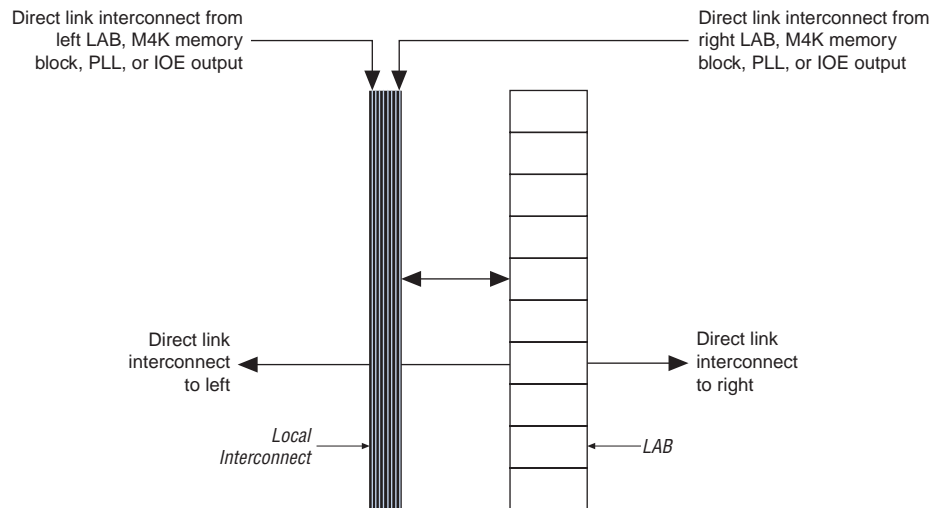

## LAB Control Signals

Each LAB contains dedicated logic for driving control signals to its LEs. The control signals include two clocks, two clock enables, two asynchronous clears, synchronous clear, asynchronous preset/load, synchronous load, and add/subtract control signals. This gives a maximum of 10 control signals at a time. Although synchronous load and clear signals are generally used when implementing counters, they can also be used with other functions.

Each LAB can use two clocks and two clock enable signals. Each LAB's clock and clock enable signals are linked. For example, any LE in a particular LAB using the `labclk1` signal will also use `labckena1`. If the LAB uses both the rising and falling edges of a clock, it also uses both LAB-wide clock signals. De-asserting the clock enable signal will turn off the LAB-wide clock.

Each LAB can use two asynchronous clear signals and an asynchronous load/preset signal. The asynchronous load acts as a preset when the asynchronous load data input is tied high.

With the LAB-wide `addsub` control signal, a single LE can implement a one-bit adder and subtractor. This saves LE resources and improves performance for logic functions such as DSP correlators and signed multipliers that alternate between addition and subtraction depending on data.

The LAB row clocks [5..0] and LAB local interconnect generate the LAB-wide control signals. The MultiTrack™ interconnect's inherent low skew allows clock and control signal distribution in addition to data. [Figure 4](#) shows the LAB control signal generation circuit.

**Figure 4. LAB-Wide Control Signals**

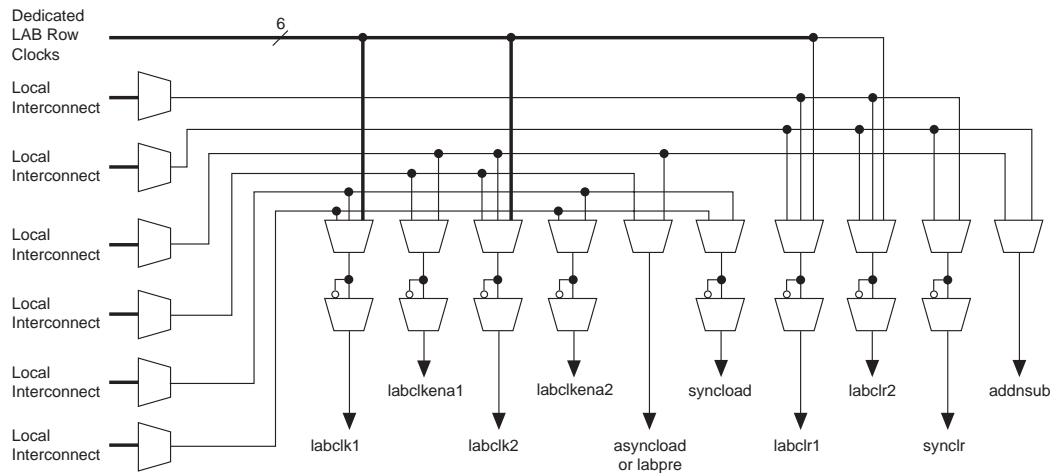

## Logic Elements

The smallest unit of logic in the Cyclone architecture, the LE, is compact and provides advanced features with efficient logic utilization. Each LE contains a four-input LUT, which is a function generator that can implement any function of four variables. In addition, each LE contains a programmable register and carry chain with carry select capability. A single LE also supports dynamic single bit addition or subtraction mode selectable by an LAB-wide control signal. Each LE drives all types of interconnects: local, row, column, LUT chain, register chain, and direct link interconnects. See Figure 5.

Figure 5. Cyclone LE

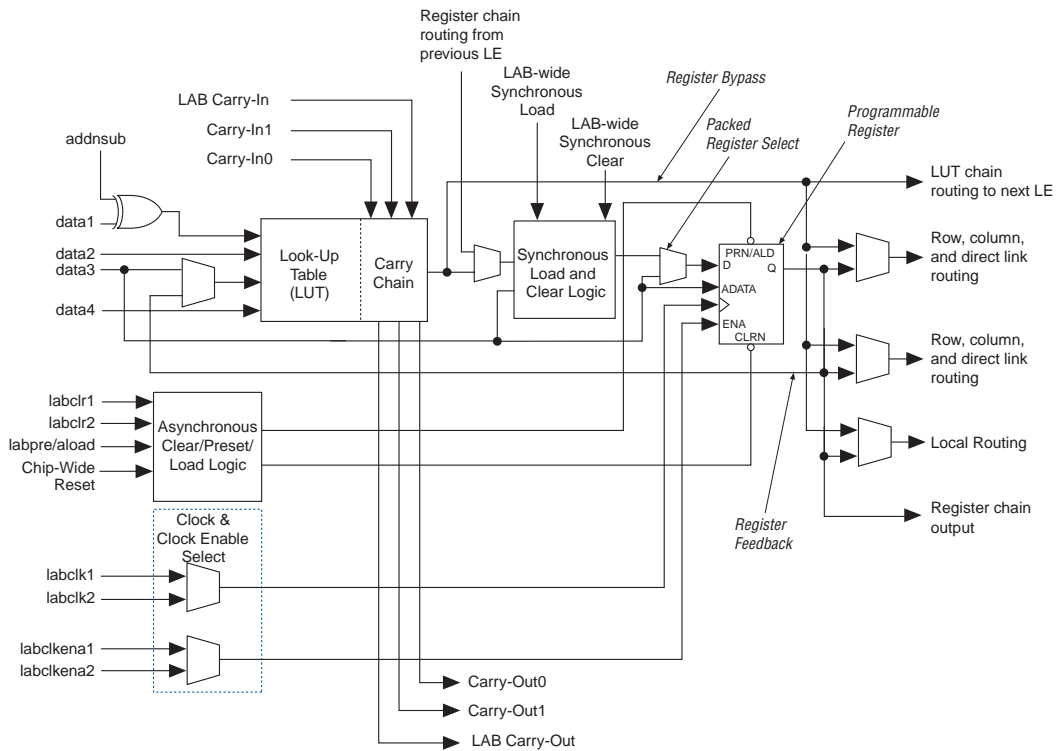

Each LE's programmable register can be configured for D, T, JK, or SR operation. Each register has data, true asynchronous load data, clock, clock enable, clear, and asynchronous load/preset inputs. Global signals, general-purpose I/O pins, or any internal logic can drive the register's clock and clear control signals. Either general-purpose I/O pins or internal logic can drive the clock enable, preset, asynchronous load, and asynchronous data. The asynchronous load data input comes from the `data3` input of the LE. For combinatorial functions, the LUT output bypasses the register and drives directly to the LE outputs.

Each LE has three outputs that drive the local, row, and column routing resources. The LUT or register output can drive these three outputs independently. Two LE outputs drive column or row and direct link routing connections and one drives local interconnect resources. This allows the LUT to drive one output while the register drives another output. This feature, called register packing, improves device utilization because the device can use the register and the LUT for unrelated functions. Another special packing mode allows the register output to feed back into the LUT of the same LE so that the register is packed with its own fan-out LUT. This provides another mechanism for improved fitting. The LE can also drive out registered and unregistered versions of the LUT output.

### LUT Chain & Register Chain

In addition to the three general routing outputs, the LEs within an LAB have LUT chain and register chain outputs. LUT chain connections allow LUTs within the same LAB to cascade together for wide input functions. Register chain outputs allow registers within the same LAB to cascade together. The register chain output allows an LAB to use LUTs for a single combinatorial function and the registers to be used for an unrelated shift register implementation. These resources speed up connections between LABs while saving local interconnect resources. See ["MultiTrack Interconnect" on page 17](#) for more information on LUT chain and register chain connections.

## addnsub Signal

The LE's dynamic adder/subtractor feature saves logic resources by using one set of LEs to implement both an adder and a subtractor. This feature is controlled by the LAB-wide control signal `addnsub`. The `addnsub` signal sets the LAB to perform either  $A + B$  or  $A - B$ . The LUT computes addition; subtraction is computed by adding the two's complement of the intended subtractor. The LAB-wide signal converts to two's complement by inverting the B bits within the LAB and setting carry-in = 1 to add one to the least significant bit (LSB). The LSB of an adder/subtractor must be placed in the first LE of the LAB, where the LAB-wide `addnsub` signal automatically sets the carry-in to 1. The Quartus II Compiler automatically places and uses the adder/subtractor feature when using adder/subtractor parameterized functions.

## LE Operating Modes

The Cyclone LE can operate in one of the following modes:

- Normal mode
- Dynamic arithmetic mode

Each mode uses LE resources differently. In each mode, eight available inputs to the LE—the four data inputs from the LAB local interconnect, `carry-in0` and `carry-in1` from the previous LE, the LAB carry-in from the previous carry-chain LAB, and the register chain connection—are directed to different destinations to implement the desired logic function. LAB-wide signals provide clock, asynchronous clear, asynchronous preset/load, synchronous clear, synchronous load, and clock enable control for the register. These LAB-wide signals are available in all LE modes. The `addnsub` control signal is allowed in arithmetic mode.

The Quartus II software, in conjunction with parameterized functions such as library of parameterized modules (LPM) functions, automatically chooses the appropriate mode for common functions such as counters, adders, subtractors, and arithmetic functions. If required, the designer can also create special-purpose functions that specify which LE operating mode to use for optimal performance.

### Normal Mode

The normal mode is suitable for general logic applications and combinatorial functions. In normal mode, four data inputs from the LAB local interconnect are inputs to a four-input LUT (see Figure 6). The Quartus II Compiler automatically selects the carry-in or the data3 signal as one of the inputs to the LUT. Each LE can use LUT chain connections to drive its combinatorial output directly to the next LE in the LAB. Asynchronous load data for the register comes from the data3 input of the LE. LEs in normal mode support packed registers.

**Figure 6. LE in Normal Mode**

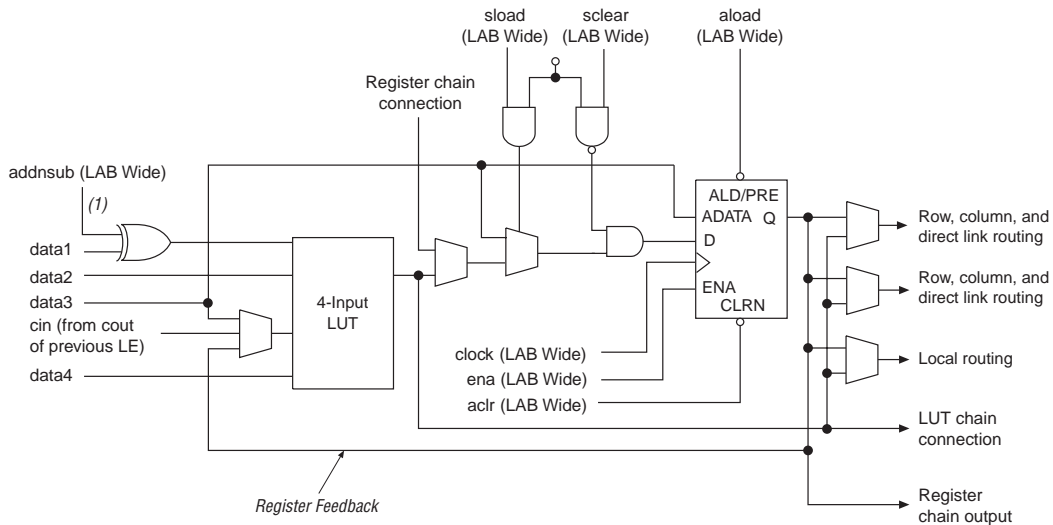

**Note to Figure 6:**

(1) This signal is only allowed in normal mode if the LE is at the end of an adder/subtractor chain.

### *Dynamic Arithmetic Mode*

The dynamic arithmetic mode is ideal for implementing adders, counters, accumulators, wide parity functions, and comparators. An LE in dynamic arithmetic mode uses four 2-input LUTs configurable as a dynamic adder/subtractor. The first two 2-input LUTs compute two summations based on a possible carry-in of 1 or 0; the other two LUTs generate carry outputs for the two chains of the carry select circuitry. As shown in [Figure 7](#), the LAB carry-in signal selects either the `carry-in0` or `carry-in1` chain. The selected chain's logic level in turn determines which parallel sum is generated as a combinatorial or registered output. For example, when implementing an adder, the sum output is the selection of two possible calculated sums:

$$\text{data1} + \text{data2} + \text{carry-in0} \text{ or } \text{data1} + \text{data2} + \text{carry-in1}.$$

The other two LUTs use the `data1` and `data2` signals to generate two possible carry-out signals—one for a carry of 1 and the other for a carry of 0. The `carry-in0` signal acts as the carry select for the `carry-out0` output and `carry-in1` acts as the carry select for the `carry-out1` output. LEs in arithmetic mode can drive out registered and unregistered versions of the LUT output.

The dynamic arithmetic mode also offers clock enable, counter enable, synchronous up/down control, synchronous clear, synchronous load, and dynamic adder/subtractor options. The LAB local interconnect data inputs generate the counter enable and synchronous up/down control signals. The synchronous clear and synchronous load options are LAB-wide signals that affect all registers in the LAB. The Quartus II software automatically places any registers that are not used by the counter into other LABs. The `addnsub` LAB-wide signal controls whether the LE acts as an adder or subtractor.



Figure 8 shows the carry-select circuitry in an LAB for a 10-bit full adder. One portion of the LUT generates the sum of two bits using the input signals and the appropriate carry-in bit; the sum is routed to the output of the LE. The register can be bypassed for simple adders or used for accumulator functions. Another portion of the LUT generates carry-out bits. An LAB-wide carry-in bit selects which chain is used for the addition of given inputs. The carry-in signal for each chain, `carry-in0` or `carry-in1`, selects the carry-out to carry forward to the carry-in signal of the next-higher-order bit. The final carry-out signal is routed to an LE, where it is fed to local, row, or column interconnects.

**Figure 8. Carry Select Chain**

The Quartus II Compiler automatically creates carry chain logic during design processing, or the designer can create it manually during design entry. Parameterized functions such as LPM functions automatically take advantage of carry chains for the appropriate functions.

The Quartus II Compiler creates carry chains longer than 10 LEs by linking LABs together automatically. For enhanced fitting, a long carry chain runs vertically allowing fast horizontal connections to M4K memory blocks. A carry chain can continue as far as a full column.

### *Clear & Preset Logic Control*

LAB-wide signals control the logic for the register's clear and preset signals. The LE directly supports an asynchronous clear and preset function. The register preset is achieved through the asynchronous load of a logic high. The direct asynchronous preset does not require a NOT-gate push-back technique. Cyclone devices support simultaneous preset/asynchronous load and clear signals. An asynchronous clear signal takes precedence if both signals are asserted simultaneously. Each LAB supports up to two clears and one preset signal.

In addition to the clear and preset ports, Cyclone devices provide a chip-wide reset pin (DEV\_CLRn) that resets all registers in the device. An option set before compilation in the Quartus II software controls this pin. This chip-wide reset overrides all other control signals.

## **MultiTrack Interconnect**

In the Cyclone architecture, connections between LEs, M4K memory blocks, and device I/O pins are provided by the MultiTrack interconnect structure with DirectDrive™ technology. The MultiTrack interconnect consists of continuous, performance-optimized routing lines of different speeds used for inter- and intra-design block connectivity. The Quartus II Compiler automatically places critical design paths on faster interconnects to improve design performance.

DirectDrive technology is a deterministic routing technology that ensures identical routing resource usage for any function regardless of placement within the device. The MultiTrack interconnect and DirectDrive technology simplify the integration stage of block-based designing by eliminating the re-optimization cycles that typically follow design changes and additions.

The MultiTrack interconnect consists of row and column interconnects that span fixed distances. A routing structure with fixed length resources for all devices allows predictable and repeatable performance when migrating through different device densities. Dedicated row interconnects route signals to and from LABs, PLLs, and M4K memory blocks within the same row. These row resources include:

- Direct link interconnects between LABs and adjacent blocks
- R4 interconnects traversing four blocks to the right or left

The direct link interconnect allows an LAB or M4K memory block to drive into the local interconnect of its left and right neighbors. Only one side of a PLL block interfaces with direct link and row interconnects. The direct link interconnect provides fast communication between adjacent LABs and/or blocks without using row interconnect resources.

The R4 interconnects span four LABs, or two LABs and one M4K RAM block. These resources are used for fast row connections in a four-LAB region. Every LAB has its own set of R4 interconnects to drive either left or right. **Figure 9** shows R4 interconnect connections from an LAB. R4 interconnects can drive and be driven by M4K memory blocks, PLLs, and row IOEs. For LAB interfacing, a primary LAB or LAB neighbor can drive a given R4 interconnect. For R4 interconnects that drive to the right, the primary LAB and right neighbor can drive on to the interconnect. For R4 interconnects that drive to the left, the primary LAB and its left neighbor can drive on to the interconnect. R4 interconnects can drive other R4 interconnects to extend the range of LABs they can drive. R4 interconnects can also drive C4 interconnects for connections from one row to another.

**Figure 9. R4 Interconnect Connections**

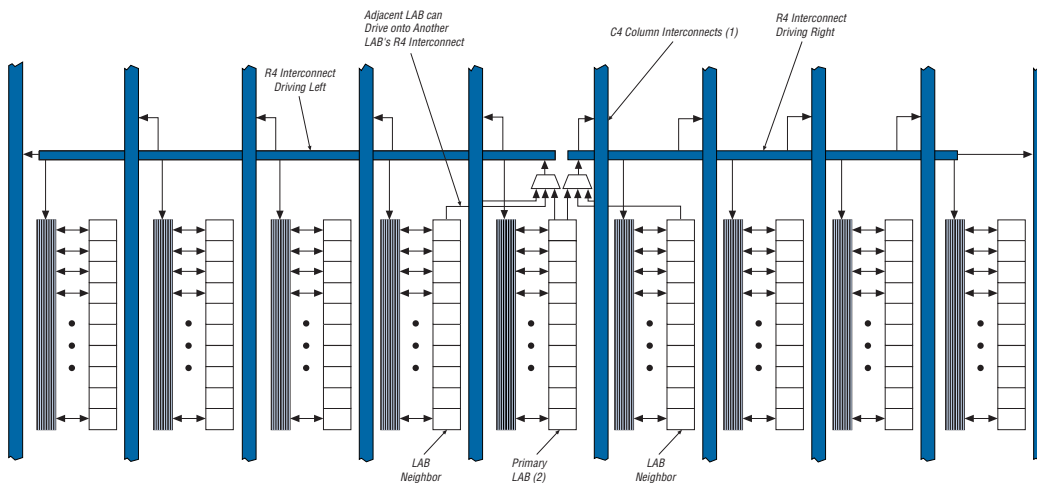

**Notes to Figure 9:**

- (1) C4 interconnects can drive R4 interconnects.
- (2) This pattern is repeated for every LAB in the LAB row.

The column interconnect operates similarly to the row interconnect. Each column of LABs is served by a dedicated column interconnect, which vertically routes signals to and from LABs, M4K memory blocks, and row and column IOEs. These column resources include:

- LUT chain interconnects within an LAB
- Register chain interconnects within an LAB
- C4 interconnects traversing a distance of four blocks in an up and down direction

Cyclone devices include an enhanced interconnect structure within LABs for routing LE output to LE input connections faster using LUT chain connections and register chain connections. The LUT chain connection allows the combinatorial output of an LE to directly drive the fast input of the LE right below it, bypassing the local interconnect. These resources can be used as a high-speed connection for wide fan-in functions from LE 1 to LE 10 in the same LAB. The register chain connection allows the register output of one LE to connect directly to the register input of the next LE in the LAB for fast shift registers. The Quartus II Compiler automatically takes advantage of these resources to improve utilization and performance. [Figure 10](#) shows the LUT chain and register chain interconnects.

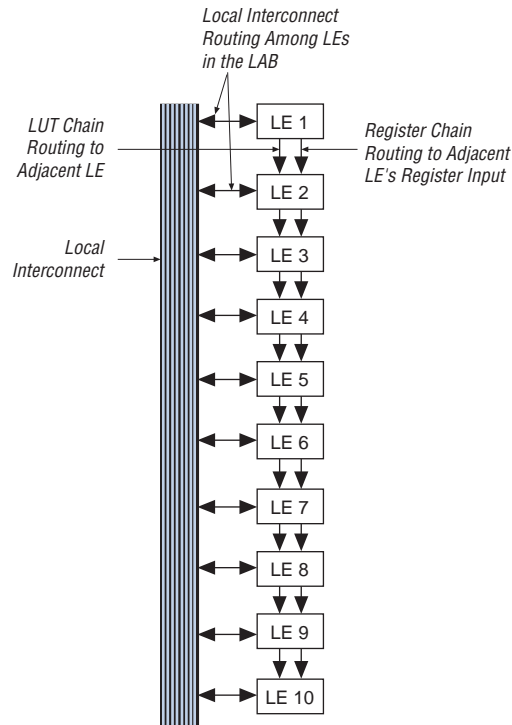
**Figure 10. LUT Chain & Register Chain Interconnects**

The C4 interconnects span four LABs or M4K blocks up or down from a source LAB. Every LAB has its own set of C4 interconnects to drive either up or down. [Figure 11](#) shows the C4 interconnect connections from an LAB in a column. The C4 interconnects can drive and be driven by all types of architecture blocks, including PLLs, M4K memory blocks, and column and row IOEs. For LAB interconnection, a primary LAB or its LAB neighbor can drive a given C4 interconnect. C4 interconnects can drive each other to extend their range as well as drive row interconnects for column-to-column connections.

Figure 11. C4 Interconnect Connections *Note (1)*

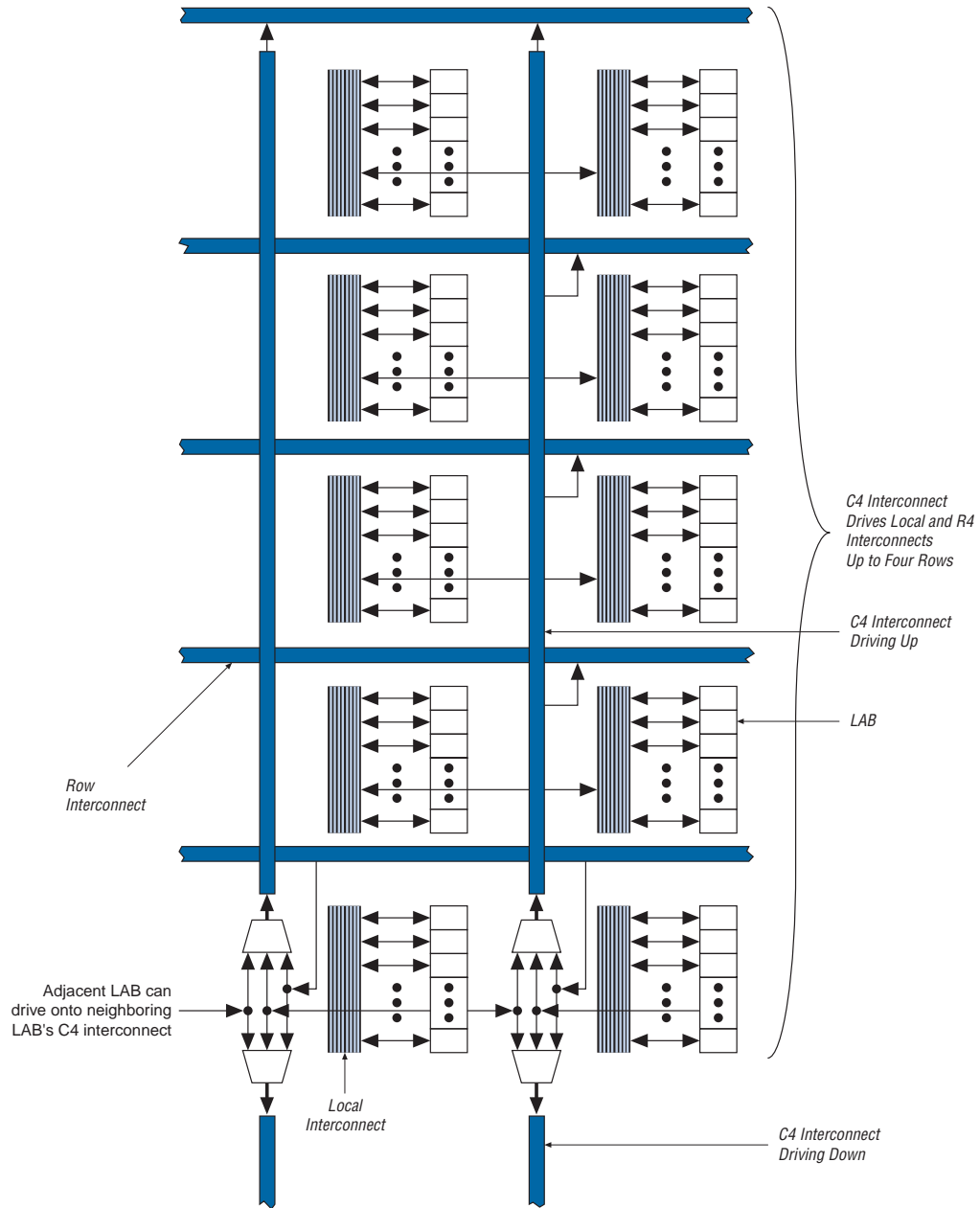

**Note to Figure 11:**

(1) Each C4 interconnect can drive either up or down four rows.

All embedded blocks communicate with the logic array similar to LAB-to-LAB interfaces. Each block (i.e., M4K memory or PLL) connects to row and column interconnects and has local interconnect regions driven by row and column interconnects. These blocks also have direct link interconnects for fast connections to and from a neighboring LAB.

Table 5 shows the Cyclone device's routing scheme.

**Table 5. Cyclone Device Routing Scheme**

Source	Destination										
	LUT Chain	Register Chain	Local Interconnect	Direct Link Interconnect	R4 Interconnect	C4 Interconnect	LE	M4K RAM Block	PLL	Column IOE	Row IOE
LUT Chain							✓				
Register Chain							✓				
Local Interconnect							✓	✓	✓	✓	✓
Direct Link Interconnect			✓								
R4 Interconnect			✓		✓	✓					
C4 Interconnect			✓		✓	✓					
LE	✓	✓	✓	✓	✓	✓					
M4K RAM Block			✓	✓	✓	✓					
PLL				✓	✓	✓					
Column IOE						✓					
Row IOE				✓	✓	✓					

## Embedded Memory

The Cyclone embedded memory consists of columns of M4K memory blocks. EP1C3 and EP1C6 devices have one column of M4K blocks, while EP1C12 and EP1C20 devices have two columns (see [Table 1 on page 1](#) for total RAM bits per density). Each M4K block can implement various types of memory with or without parity, including true dual-port, simple dual-port, and single-port RAM, ROM, and FIFO buffers. The M4K blocks support the following features:

- 4,608 RAM bits
- 200 MHz performance
- True dual-port memory
- Simple dual-port memory
- Single-port memory
- Byte enable
- Parity bits
- Shift register
- FIFO buffer
- ROM
- Mixed clock mode

### Memory Modes

The M4K memory blocks include input registers that synchronize writes and output registers to pipeline designs and improve system performance. M4K blocks offer a true dual-port mode to support any combination of two-port operations: two reads, two writes, or one read and one write at two different clock frequencies. [Figure 12](#) shows true dual-port memory.

**Figure 12. True Dual-Port Memory Configuration**



In addition to true dual-port memory, the M4K memory blocks support simple dual-port and single-port RAM. Simple dual-port memory supports a simultaneous read and write. Single-port memory supports non-simultaneous reads and writes. [Figure 13](#) shows these different M4K RAM memory port configurations.

**Figure 13. Simple Dual-Port & Single-Port Memory Configurations****Note to Figure 13:**

- (1) Two single-port memory blocks can be implemented in a single M4K block as long as each of the two independent block sizes is equal to or less than half of the M4K block size.

The memory blocks also enable mixed-width data ports for reading and writing to the RAM ports in dual-port RAM configuration. For example, the memory block can be written in  $\times 1$  mode at port A and read out in  $\times 16$  mode from port B.

The Cyclone memory architecture can implement fully synchronous RAM by registering both the input and output signals to the M4K RAM block. All M4K memory block inputs are registered, providing synchronous write cycles. In synchronous operation, the memory block generates its own self-timed strobe write enable (*wren*) signal derived from a global clock. In contrast, a circuit using asynchronous RAM must generate the RAM *wren* signal while ensuring its data and address signals meet setup and hold time specifications relative to the *wren* signal. The output registers can be bypassed. Pseudo-asynchronous reading is possible in the simple dual-port mode of M4K blocks by clocking the read enable and read address registers on the negative clock edge and bypassing the output registers.

When configured as RAM or ROM, the designer can use an initialization file to pre-load the memory contents.

Two single-port memory blocks can be implemented in a single M4K block as long as each of the two independent block sizes is equal to or less than half of the M4K block size.

The Quartus II software automatically implements larger memory by combining multiple M4K memory blocks. For example, two  $256 \times 16$ -bit RAM blocks can be combined to form a  $256 \times 32$ -bit RAM block. Memory performance does not degrade for memory blocks using the maximum number of words allowed. Logical memory blocks using less than the maximum number of words use physical blocks in parallel, eliminating any external control logic that would increase delays. To create a larger high-speed memory block, the Quartus II software automatically combines memory blocks with LE control logic.

### Parity Bit Support

The M4K blocks support a parity bit for each byte. The parity bit, along with internal LE logic, can implement parity checking for error detection to ensure data integrity. Designers can also use parity-size data words to store user-specified control bits. Byte enables are also available for data input masking during write operations.

### Shift Register Support

The designer can configure M4K memory blocks to implement shift registers for DSP applications such as pseudo-random number generators, multi-channel filtering, auto-correlation, and cross-correlation functions. These and other DSP applications require local data storage, traditionally implemented with standard flip-flops, which can quickly consume many logic cells and routing resources for large shift registers. A more efficient alternative is to use embedded memory as a shift register block, which saves logic cell and routing resources and provides a more efficient implementation with the dedicated circuitry.

The size of a  $w \times m \times n$  shift register is determined by the input data width ( $w$ ), the length of the taps ( $m$ ), and the number of taps ( $n$ ). The size of a  $w \times m \times n$  shift register must be less than or equal to the maximum number of memory bits in the M4K block (4,608 bits). The total number of shift register outputs (number of taps  $n \times$  width  $w$ ) must be less than the maximum data width of the M4K RAM block ( $\times 36$ ). To create larger shift registers, multiple memory blocks are cascaded together.

Data is written into each address location at the falling edge of the clock and read from the address at the rising edge of the clock. The shift register mode logic automatically controls the positive and negative edge clocking to shift the data in one clock cycle. Figure 14 shows the M4K memory block in the shift register mode.

**Figure 14. Shift Register Memory Configuration**



## Memory Configuration Sizes

The memory address depths and output widths can be configured as  $4,096 \times 1$ ,  $2,048 \times 2$ ,  $1,024 \times 4$ ,  $512 \times 8$  (or  $512 \times 9$  bits),  $256 \times 16$  (or  $256 \times 18$  bits), and  $128 \times 32$  (or  $128 \times 36$  bits). The  $128 \times 32$ - or  $36$ -bit configuration is not available in the true dual-port mode. Mixed-width configurations are also possible, allowing different read and write widths. Tables 6 and 7 summarize the possible M4K RAM block configurations.

**Table 6. M4K RAM Block Configurations (Simple Dual-Port)**

Read Port	Write Port								
	4K × 1	2K × 2	1K × 4	512 × 8	256 × 16	128 × 32	512 × 9	256 × 18	128 × 36
4K × 1	✓	✓	✓	✓	✓	✓			
2K × 2	✓	✓	✓	✓	✓	✓			
1K × 4	✓	✓	✓	✓	✓	✓			
512 × 8	✓	✓	✓	✓	✓	✓			
256 × 16	✓	✓	✓	✓	✓	✓			
128 × 32	✓	✓	✓	✓	✓	✓			
512 × 9							✓	✓	✓
256 × 18							✓	✓	✓
128 × 36							✓	✓	✓

**Table 7. M4K RAM Block Configurations (True Dual-Port)**

Port A	Port B						
	4K × 1	2K × 2	1K × 4	512 × 8	256 × 16	512 × 9	256 × 18
4K × 1	✓	✓	✓	✓	✓		
2K × 2	✓	✓	✓	✓	✓		
1K × 4	✓	✓	✓	✓	✓		
512 × 8	✓	✓	✓	✓	✓		
256 × 16	✓	✓	✓	✓	✓		
512 × 9						✓	✓
256 × 18						✓	✓

When the M4K RAM block is configured as a shift register block, the designer can create a shift register up to 4,608 bits ( $w \times m \times n$ ).

## Byte Enables

M4K blocks support byte writes when the write port has a data width of 16, 18, 32, or 36 bits. The byte enables allow the input data to be masked so the device can write to specific bytes. The unwritten bytes retain the previous written value. [Table 8](#) summarizes the byte selection.

<b>byteena[3..0]</b>	<b>datain ×18</b>	<b>datain ×36</b>
[0] = 1	[8..0]	[8..0]
[1] = 1	[17..9]	[17..9]
[2] = 1	–	[26..18]
[3] = 1	–	[35..27]

### Notes to [Table 8](#):

- (1) Any combination of byte enables is possible.
- (2) Byte enables can be used in the same manner with 8-bit words, i.e., in ×16 and ×32 modes.

## Control Signals & M4K Interface

The M4K blocks allow for different clocks on their inputs and outputs. Either of the two clocks feeding the block can clock M4K block registers (*renwe*, address, byte enable, *datain*, and output registers). Only the output register can be bypassed. The six *labclk* signals or local interconnects can drive the control signals for the A and B ports of the M4K block. LEs can also control the *clock\_a*, *clock\_b*, *renwe\_a*, *renwe\_b*, *clr\_a*, *clr\_b*, *clocken\_a*, and *clocken\_b* signals, as shown in [Figure 15](#).

The R4, C4, and direct link interconnects from adjacent LABs drive the M4K block local interconnect. The M4K blocks can communicate with LABs on either the left or right side through these row resources or with LAB columns on either the right or left with the column resources. Up to 10 direct link input connections to the M4K block are possible from the left adjacent LABs and another 10 possible from the right adjacent LAB. M4K block outputs can also connect to left and right LABs through 10 direct link interconnects each. [Figure 16](#) shows the M4K block to logic array interface.

**Figure 15. M4K RAM Block Control Signals**



**Figure 16. M4K RAM Block LAB Row Interface**

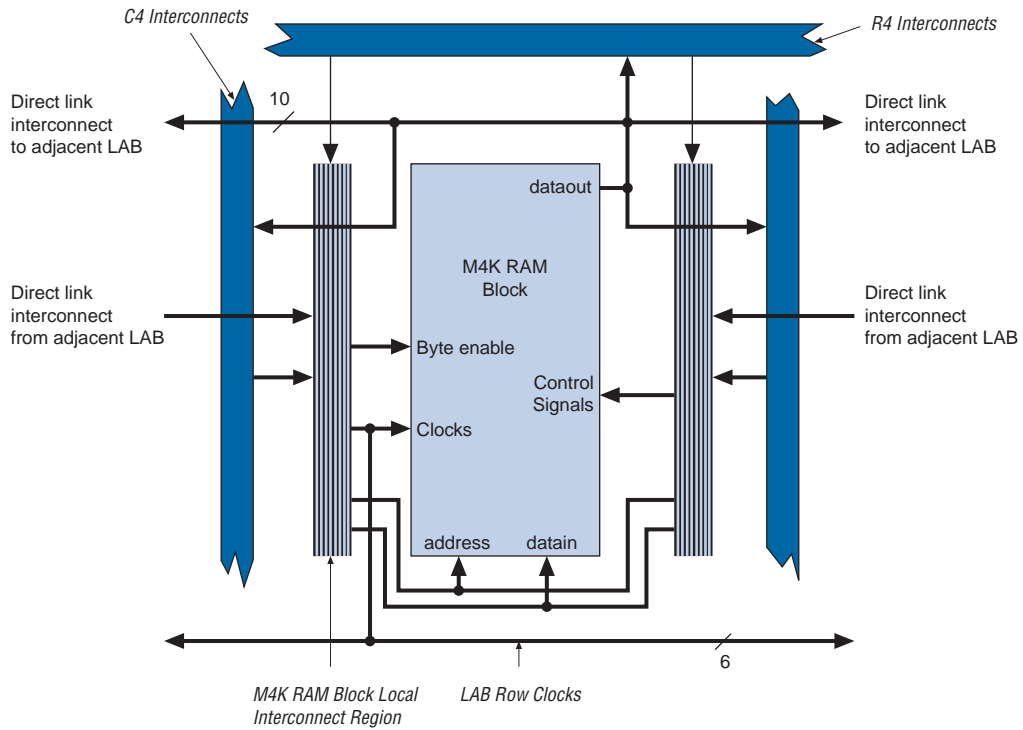

## Independent Clock Mode

The M4K memory blocks implement independent clock mode for true dual-port memory. In this mode, a separate clock is available for each port (ports A and B). Clock A controls all registers on the port A side, while clock B controls all registers on the port B side. Each port, A and B, also supports independent clock enables and asynchronous clear signals for port A and B registers. Figure 17 shows an M4K memory block in independent clock mode.

**Figure 17. Independent Clock Mode** *Note (1)*

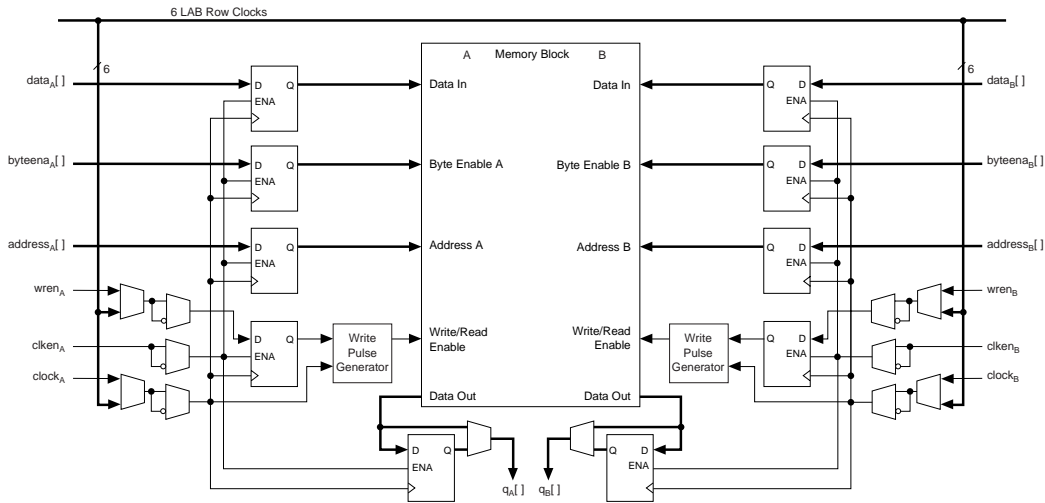

*Note to Figure 17:*

- (1) All registers shown have asynchronous clear ports.

## Input/Output Clock Mode

Input/output clock mode can be implemented for both the true and simple dual-port memory modes. On each of the two ports, A or B, one clock controls all registers for inputs into the memory block: data input, wren, and address. The other clock controls the block's data output registers. Each memory block port, A or B, also supports independent clock enables and asynchronous clear signals for input and output registers. Figures 18 and 19 show the memory block in input/output clock mode.

**Figure 18. Input/Output Clock Mode in True Dual-Port Mode** *Note (1)*



**Note to Figure 18:**

(1) All registers shown have asynchronous clear ports.

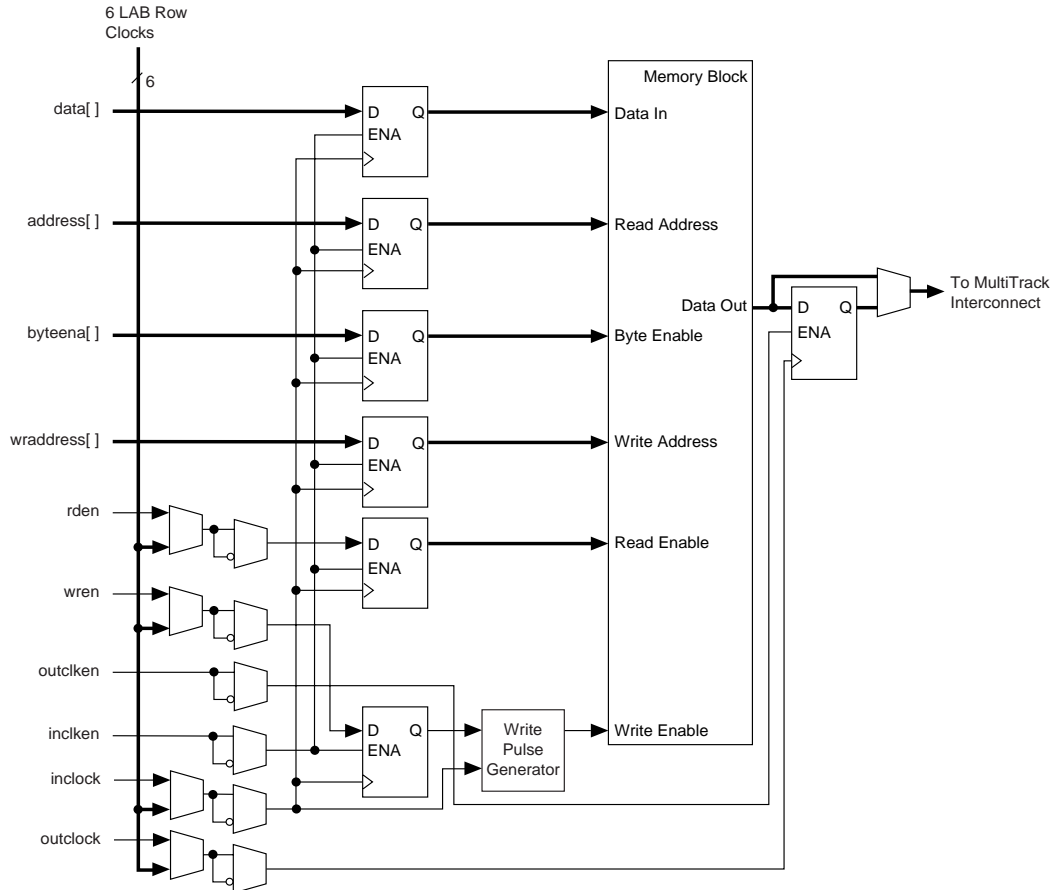
**Figure 19. Input/Output Clock Mode in Simple Dual-Port Mode** *Note (1)***Note to Figures 19:**

(1) All registers shown except the rden register have asynchronous clear ports.

## Read/Write Clock Mode

The M4K memory blocks implement read/write clock mode for simple dual-port memory. The designer can use up to two clocks in this mode. The write clock controls the block's data inputs, *wraddress*, and *wren*. The read clock controls the data output, *rdaddress*, and *rden*. The memory blocks support independent clock enables for each clock and asynchronous clear signals for the read- and write-side registers. [Figure 20](#) shows a memory block in read/write clock mode.

**Figure 20. Read/Write Clock Mode in Simple Dual-Port Mode** *Note (1)*



**Note to Figure 20:**

(1) All registers shown except the rden register have asynchronous clear ports.

### Single-Port Mode

The M4K memory blocks also support single-port mode, used when simultaneous reads and writes are not required. See Figure 21. A single M4K memory block can support up to two single-port mode RAM blocks if each RAM block is less than or equal to 2K bits in size.

**Figure 21. Single-Port Mode**

## Global Clock Network & Phase-Locked Loops

Cyclone devices provide a global clock network and up to two PLLs for a complete clock management solution.

### Global Clock Network

There are four dedicated clock pins ( $CLK[3..0]$ ), two pins on the left side and two pins on the right side) that drive the global clock network, as shown in [Figure 22](#). PLL outputs, logic array, and dual-purpose clock ( $DPCLK[7..0]$ ) pins can also drive the global clock network.

The eight global clock lines in the global clock network drive throughout the entire device. The global clock network can provide clocks for all resources within the device—IOEs, LEs, and memory blocks. The global clock lines can also be used for control signals, such as clock enables and synchronous or asynchronous clears fed from the external pin, or DQS signals for DDR SDRAM or FCRAM interfaces. Internal logic can also drive the global clock network for internally generated global clocks and asynchronous clears, clock enables, or other control signals with large fanout. [Figure 22](#) shows the various sources that drive the global clock network.

Figure 22. Global Clock Generation *Note (1)*

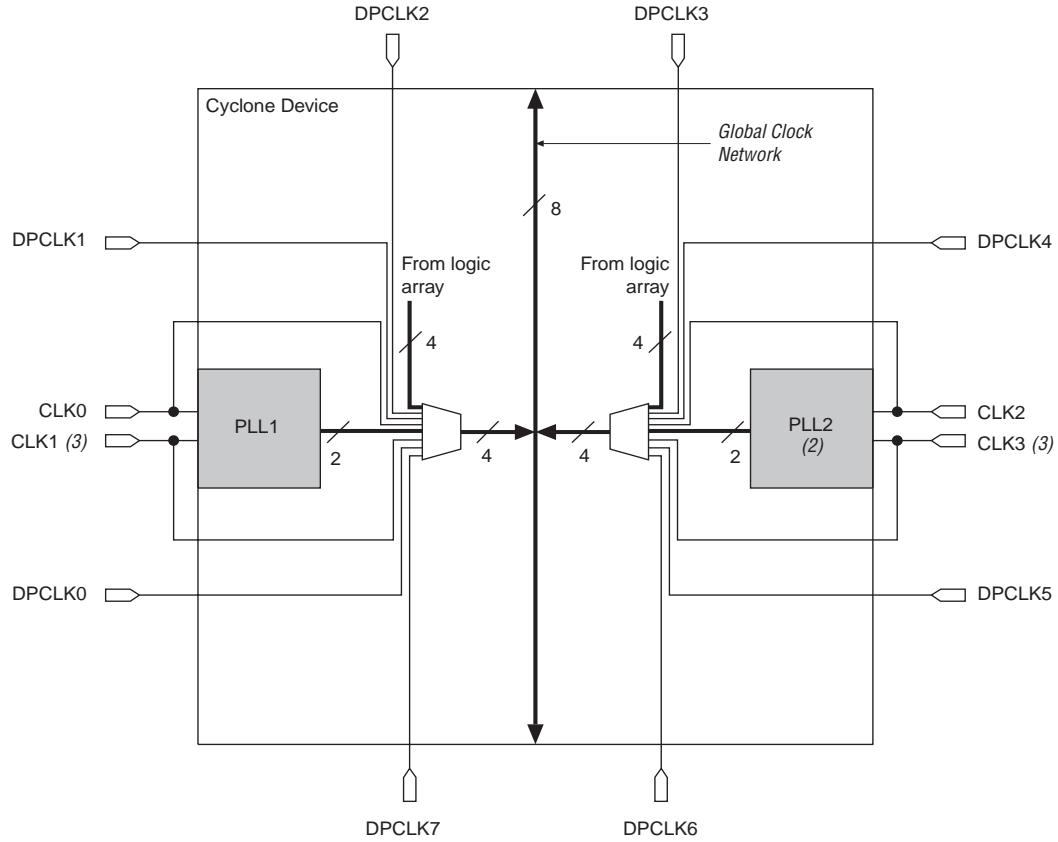

Notes to Figure 22:

- (1) The EP1C3 device in the 100-pin TQFP package has five DPCLK pins (DPCLK2, DPCLK3, DPCLK4, DPCLK6, and DPCLK7).
- (2) EP1C3 devices only contain one PLL (PLL 1).
- (3) The EP1C3 device in the 100-pin TQFP package does not have dedicated clock pins CLK1 and CLK3.

## Dual-Purpose Clock Pins

Each Cyclone device except the EP1C3 device has eight dual-purpose clock pins,  $DPCLK[7..0]$  (two on each I/O bank). EP1C3 devices have five  $DPCLK$  pins in the 100-pin TQFP package. These dual-purpose pins can connect to the global clock network (see [Figure 22](#)) for high-fanout control signals such as clocks, asynchronous clears, presets, and clock enables, or protocol control signals such as  $TRDY$  and  $IRDY$  for PCI, or  $DQS$  signals for external memory interfaces.

## Combined Resources

Each Cyclone device contains eight distinct dedicated clocking resources. The device uses multiplexers with these clocks to form six-bit buses to drive LAB row clocks, column IOE clocks, or row IOE clocks. See [Figure 23](#). Another multiplexer at the LAB level selects two of the six LAB row clocks to feed the LE registers within the LAB.

**Figure 23. Global Clock Network Multiplexers**

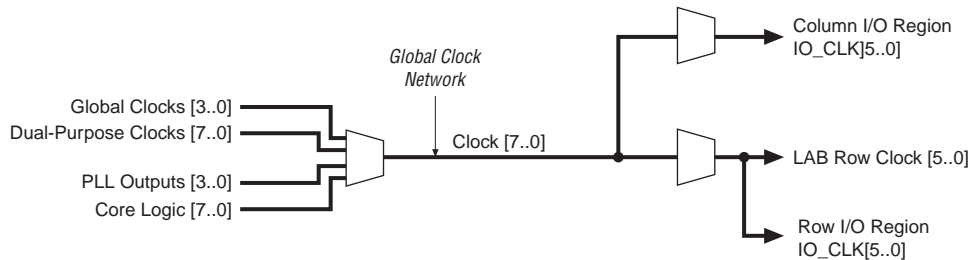

IOE clocks have row and column block regions. Six of the eight global clock resources feed to these row and column regions. [Figure 24](#) shows the I/O clock regions.

Figure 24. I/O Clock Regions



### PLLs

Cyclone PLLs provide general-purpose clocking with clock multiplication and phase shifting as well as outputs for differential I/O support. Cyclone devices contain two PLLs, except for the EP1C3 device, which contains one PLL.

Table 9 shows the PLL features in Cyclone devices. Figure 25 shows a Cyclone PLL.

Feature	PLL Support
Clock multiplication and division	$m/(n \times \text{post-scale counter})$ (1)
Phase shift	Down to 156-ps increments (2), (3)
Programmable duty cycle	Yes
Number of internal clock outputs	2
Number of external clock outputs	One differential or one single-ended (4)

**Notes to Table 9:**

- (1) The  $m$  counter ranges from 2 to 32. The  $n$  counter and the post-scale counters range from 1 to 32.
- (2) The smallest phase shift is determined by the voltage-controlled oscillator (VCO) period divided by 8.
- (3) For degree increments, Cyclone devices can shift all output frequencies in increments of 45°. Smaller degree increments are possible depending on the frequency and divide parameters.
- (4) The EP1C3 device in the 100-pin TQFP package does not support external clock output. The EP1C6 device in the 144-pin TQFP package does not support external clock output from PLL2.

**Figure 25. Cyclone PLL** Note (1)

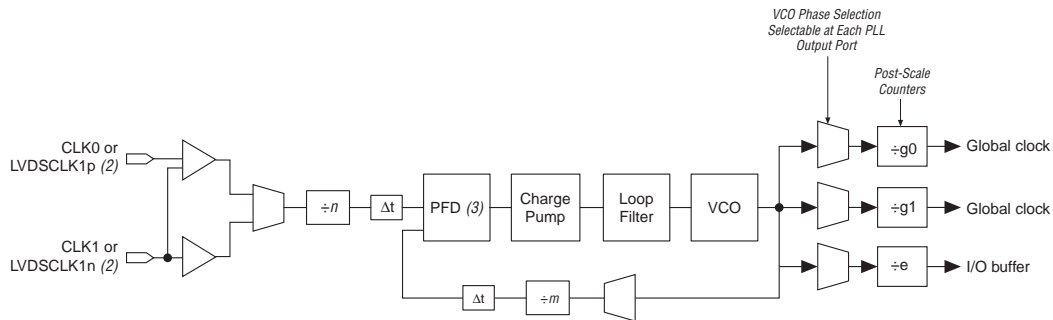

**Notes to Figure 25:**

- (1) The EP1C3 device in the 100-pin TQFP package does not support external outputs or LVDS inputs. The EP1C6 device in the 144-pin TQFP package does not support external output from PLL2.
- (2) LVDS input is supported via the secondary function of the dedicated clock pins. For PLL 1, the CLK0 pin's secondary function is LVDSCLK1p and the CLK1 pin's secondary function is LVDSCLK1n. For PLL 2, the CLK2 pin's secondary function is LVDSCLK2p and the CLK3 pin's secondary function is LVDSCLK2n.
- (3) PFD: phase frequency detector.

Figure 26 shows the PLL global clock connections.

**Figure 26. Cyclone PLL Global Clock Connections****Notes to Figure 26:**

- (1) PLL 1 supports one single-ended or LVDS input via pins CLK0 and CLK1.
- (2) PLL2 supports one single-ended or LVDS input via pins CLK2 and CLK3.
- (3) PLL1\_OUT and PLL2\_OUT support single-ended or LVDS output. If external output is not required, these pins are available as regular user I/O pins.
- (4) The EP1C3 device in the 100-pin TQFP package does not support external clock output. The EP1C6 device in the 144-pin TQFP package does not support external clock output from PLL2.

Table 10 shows the global clock network sources available in Cyclone devices.

Source		GCLK0	GCLK1	GCLK2	GCLK3	GCLK4	GCLK5	GCLK6	GCLK7
PLL Counter Output	PLL1 G0		✓	✓					
	PLL1 G1	✓			✓				
	PLL2 G0 (1)						✓	✓	
	PLL2 G1 (1)					✓			✓
Dedicated Clock Input Pins	CLK0	✓		✓					
	CLK1 (2)		✓		✓				
	CLK2					✓		✓	
	CLK3 (2)						✓		✓
Dual-Purpose Clock Pins	DPCLK0 (3)				✓				
	DPCLK1 (3)			✓					
	DPCLK2	✓							
	DPCLK3					✓			
	DPCLK4							✓	
	DPCLK5 (3)								✓
	DPCLK6						✓		
	DPCLK7		✓						

**Notes to Table 10:**

- (1) EP1C3 devices only have one PLL (PLL 1).
- (2) EP1C3 devices in the 100-pin TQFP package do not have dedicated clock pins CLK1 and CLK3.
- (3) EP1C3 devices in the 100-pin TQFP package do not have the DPCLK0, DPCLK1, or DPCLK5 pins.

## Clock Multiplication & Division

Cyclone PLLs provide clock synthesis for PLL output ports using  $m/(n \times \text{post scale counter})$  scaling factors. The input clock is divided by a pre-scale divider,  $n$ , and is then multiplied by the  $m$  feedback factor. The control loop drives the VCO to match  $f_{IN} \times (m/n)$ . Each output port has a unique post-scale counter to divide down the high-frequency VCO. For multiple PLL outputs with different frequencies, the VCO is set to the least-common multiple of the output frequencies that meets its frequency specifications. Then, the post-scale dividers scale down the output frequency for each output port. For example, if the output frequencies required from one PLL are 33 and 66 MHz, the VCO is set to 330 MHz (the least-common multiple in the VCO's range).

Each PLL has one pre-scale divider,  $n$ , that can range in value from 1 to 32. Each PLL also has one multiply divider,  $m$ , that can range in value from 2 to 32. Global clock outputs have two post scale G dividers for global clock outputs, and external clock outputs have an E divider for external clock output, both ranging from 1 to 32. The Quartus II software automatically chooses the appropriate scaling factors according to the input frequency, multiplication, and division values entered.

### External Clock Inputs

Each PLL supports single-ended or differential inputs for source-synchronous receivers or for general-purpose use. The dedicated clock pins (CLK[ 3 . . 0 ]) feed the PLL inputs. These dual-purpose pins can also act as LVDS input pins. See [Figure 25](#).

[Table 11](#) shows the I/O standards supported by PLL input and output pins.

I/O Standard	CLK Input	EXTCLK Output
3.3-V LVTTTL/LVCMOS	✓	✓
2.5-V LVTTTL/LVCMOS	✓	✓
1.8-V LVTTTL/LVCMOS	✓	✓
1.5-V LVCMOS	✓	✓
3.3-V PCI	✓	✓
LVDS	✓	✓
SSTL-2 class I	✓	✓
SSTL-2 class II	✓	✓
SSTL-3 class I	✓	✓
SSTL-3 class II	✓	✓
Differential SSTL-2		✓

For more information on LVDS I/O support, see [“LVDS I/O Pins” on page 59](#).

### External Clock Outputs

Each PLL supports one differential or one single-ended output for source-synchronous transmitters or for general-purpose external clocks. If the PLL does not use these PLL\_OUT pins, the pins are available for use as general-purpose I/O pins. The PLL\_OUT pins support all I/O standards shown in [Table 11](#).

The external clock outputs do not have their own  $V_{CC}$  and ground voltage supplies. Therefore, to minimize jitter, do not place switching I/O pins next to these output pins. The EP1C3 device in the 100-pin TQFP package does not have dedicated clock output pins. The EP1C6 device in the 144-pin TQFP package only supports dedicated clock outputs from PLL 1.

### Clock Feedback

Cyclone PLLs have three modes for multiplication and/or phase shifting:

- Zero delay buffer mode—The external clock output pin is phase-aligned with the clock input pin for zero delay.
- Normal mode—If the design uses an internal PLL clock output, the normal mode compensates for the internal clock delay from the input clock pin to the IOE registers. The external clock output pin is phase shifted with respect to the clock input pin if connected in this mode. The designer defines which internal clock output from the PLL should be phase-aligned to compensate for internal clock delay.
- No compensation mode—In this mode, the PLL will not compensate for any clock networks.

### Phase Shifting

Cyclone PLLs have an advanced clock shift capability that enables programmable phase shifts. Designers can enter a phase shift (in degrees or time units) for each PLL clock output port or for all outputs together in one shift. Designers can perform phase shifting in time units with a resolution range of 156 to 417 ps. The finest resolution equals one eighth of the VCO period. The VCO period is a function of the frequency input and the multiplication and division factors. Each clock output counter can choose a different phase of the VCO period from up to eight taps. Designers can use this clock output counter along with an initial setting on the post-scale counter to achieve a phase-shift range for the entire period of the output clock. The phase tap feedback to the m counter can shift all outputs to a single phase. The Quartus II software automatically sets the phase taps and counter settings according to the phase shift entered.

### Lock Detect Signal

The lock output indicates that there is a stable clock output signal in phase with the reference clock. Without any additional circuitry, the lock signal may toggle as the PLL begins tracking the reference clock. Therefore, the designer may need to gate the lock signal for use as a system-control signal.

## Programmable Duty Cycle

The programmable duty cycle allows PLLs to generate clock outputs with a variable duty cycle. This feature is supported on each PLL post-scale counter (g0, g1, e). The duty cycle setting is achieved by a low- and high-time count setting for the post-scale dividers. The Quartus II software uses the frequency input and the required multiply or divide rate to determine the duty cycle choices.

## Control Signals

There are three control signals for clearing and enabling PLLs and their outputs. The designer can use these signals to control PLL resynchronization and the ability to gate PLL output clocks for low-power applications.

The `pllenable` signal enables and disables PLLs. When the `pllenable` signal is low, the clock output ports are driven by ground and all the PLLs go out of lock. When the `pllenable` signal goes high again, the PLLs relock and resynchronize to the input clocks. An input pin or LE output can drive the `pllenable` signal.

The `areset` signals are reset/resynchronization inputs for each PLL. Cyclone devices can drive these input signals from input pins or from LEs. When `areset` is driven high, the PLL counters will reset, clearing the PLL output and placing the PLL out of lock. When driven low again, the PLL will resynchronize to its input as it relocks.

The `pfdena` signals control the phase frequency detector (PFD) output with a programmable gate. If you disable the PFD, the VCO will operate at its last set value of control voltage and frequency with some drift, and the system will continue running when the PLL goes out of lock or the input clock disables. By maintaining the last locked frequency, the system has time to store its current settings before shutting down. The designer can either use their own control signal or gated locked status signals to trigger the `pfdena` signal.



For more information on Cyclone PLLs, see *AN 251: Using PLLs in Cyclone Devices*.

## I/O Structure

IOEs support many features, including:

- Differential and single-ended I/O standards
- 3.3-V, 32-bit, 66-MHz PCI compliance
- Joint Test Action Group (JTAG) boundary-scan test (BST) support
- Output drive strength control
- Weak pull-up resistors during configuration
- Slew-rate control
- Tri-state buffers
- Bus-hold circuitry
- Programmable pull-up resistors in user mode
- Programmable input and output delays
- Open-drain outputs
- DQ and DQS I/O pins

Cyclone device IOEs contain a bidirectional I/O buffer and three registers for complete embedded bidirectional single data rate transfer. [Figure 27](#) shows the Cyclone IOE structure. The IOE contains one input register, one output register, and one output enable register. The designer can use the input registers for fast setup times and output registers for fast clock-to-output times. Additionally, the designer can use the output enable (OE) register for fast clock-to-output enable timing. The Quartus II software automatically duplicates a single OE register that controls multiple output or bidirectional pins. IOEs can be used as input, output, or bidirectional pins.

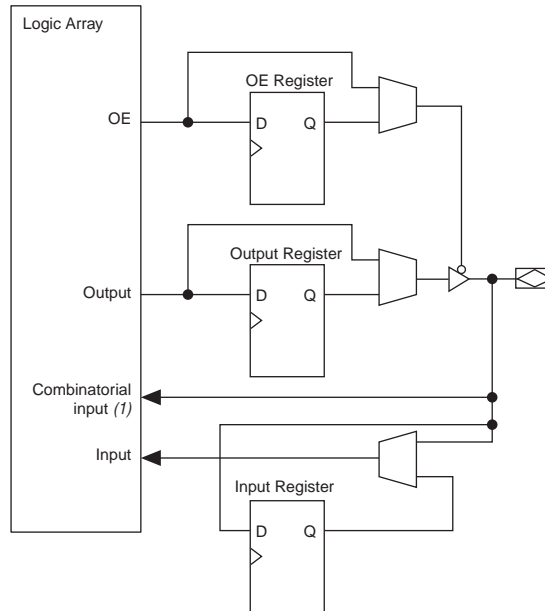
**Figure 27. Cyclone IOE Structure****Note to Figure 27:**

- (1) There are two paths available for combinatorial inputs to the logic array. Each path contains a unique programmable delay chain.

The IOEs are located in I/O blocks around the periphery of the Cyclone device. There are up to three IOEs per row I/O block and up to three IOEs per column I/O block (column I/O blocks span two columns). The row I/O blocks drive row, column, or direct link interconnects. The column I/O blocks drive column interconnects. [Figure 28](#) shows how a row I/O block connects to the logic array. [Figure 29](#) shows how a column I/O block connects to the logic array.

Figure 28. Row I/O Block Connection to the Interconnect

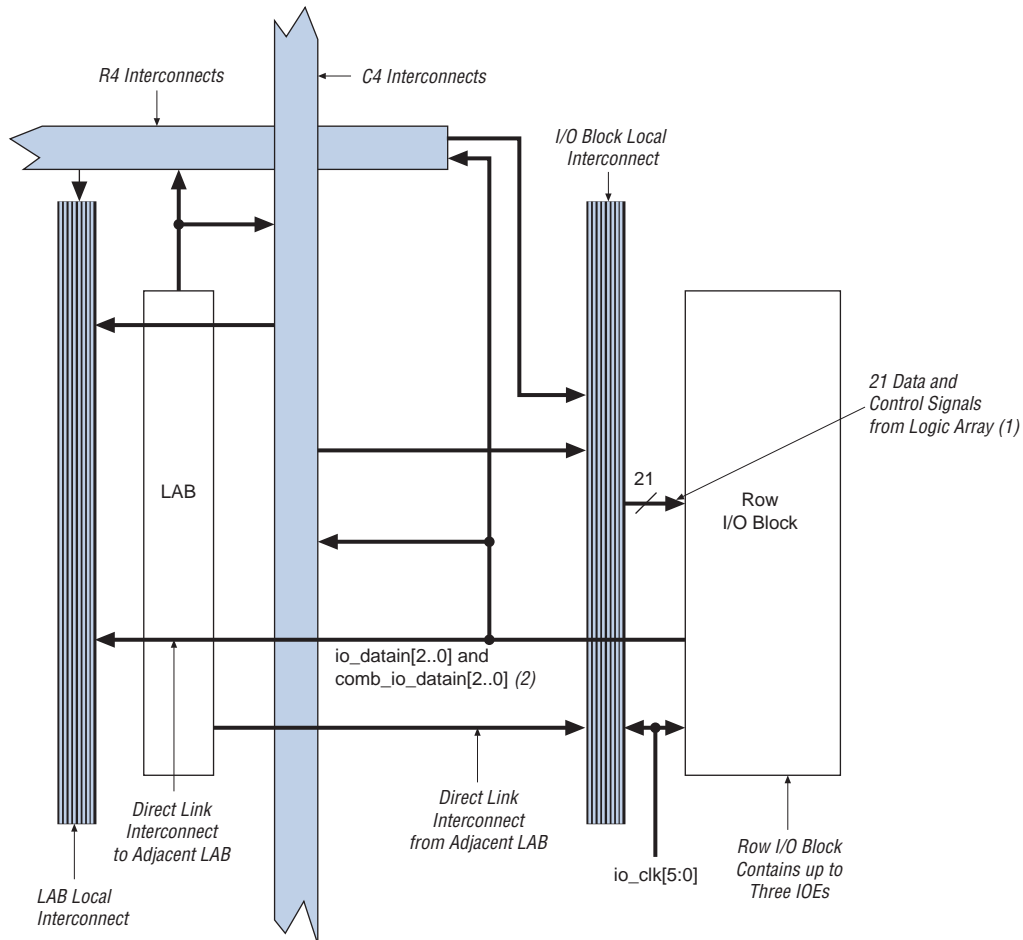
**Notes to Figure 28:**

- (1) The 21 data and control signals consist of three data out lines,  $io\_dataout[2..0]$ , three output enables,  $io\_coe[2..0]$ , three input clock enables,  $io\_cce\_in[2..0]$ , three output clock enables,  $io\_cce\_out[2..0]$ , three clocks,  $io\_clk[2..0]$ , three asynchronous clear signals,  $io\_caclr[2..0]$ , and three synchronous clear signals,  $io\_csclr[2..0]$ .
- (2) Each of the three IOEs in the row I/O block can have one  $io\_datain$  input (combinatorial or registered) and one  $comb\_io\_datain$  (combinatorial) input.

Figure 29. Column I/O Block Connection to the Interconnect

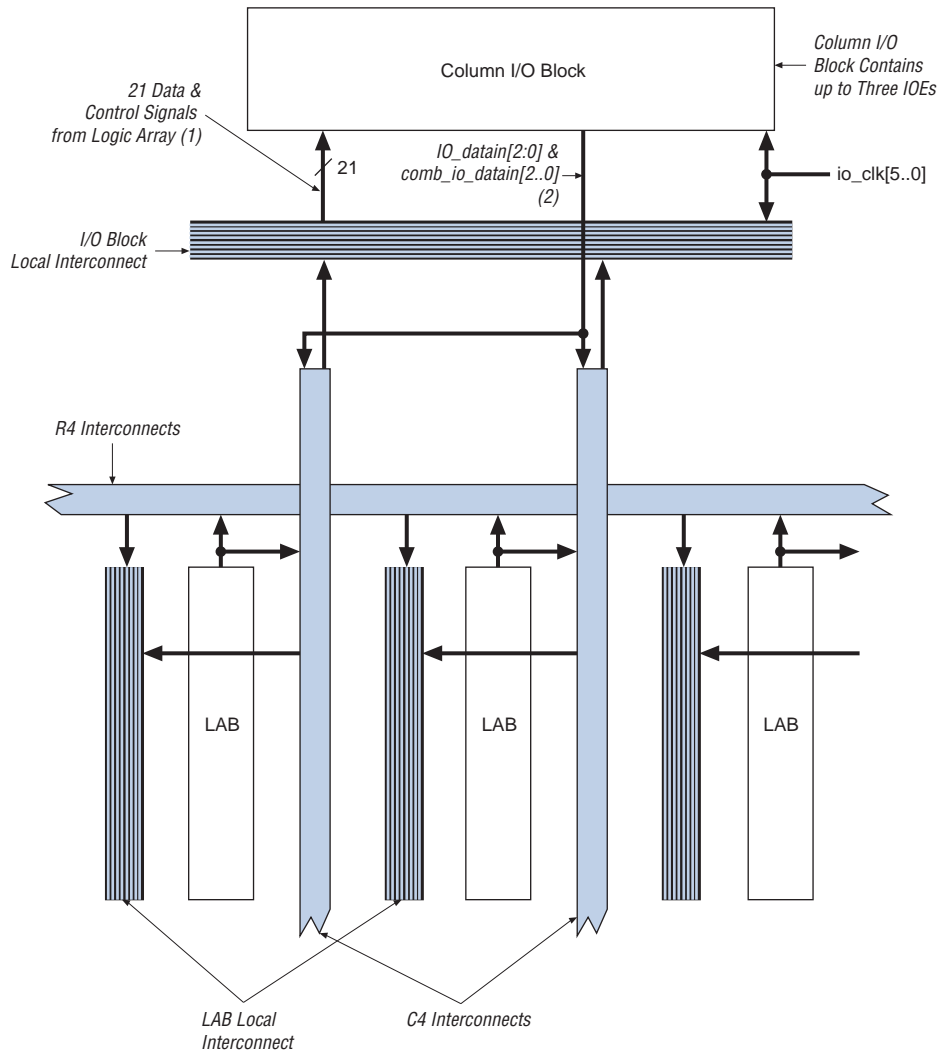
**Notes to Figure 29:**

- (1) The 21 data and control signals consist of three data out lines,  $io\_dataout[2..0]$ , three output enables,  $io\_coe[2..0]$ , three input clock enables,  $io\_cce\_in[2..0]$ , three output clock enables,  $io\_cce\_out[2..0]$ , three clocks,  $io\_clk[2..0]$ , three asynchronous clear signals,  $io\_caclr[2..0]$ , and three synchronous clear signals,  $io\_csclr[2..0]$ .
- (2) Each of the three IOEs in the column I/O block can have one  $io\_datain$  input (combinatorial or registered) and one  $comb\_io\_datain$  (combinatorial) input.

The pin's datain signals can drive the logic array. The logic array drives the control and data signals, providing a flexible routing resource. The row or column IOE clocks, `io_clk[5..0]`, provide a dedicated routing resource for low-skew, high-speed clocks. The global clock network generates the IOE clocks that feed the row or column I/O regions (see [“Global Clock Network & Phase-Locked Loops”](#) on page 34). Figure 30 illustrates the signal paths through the I/O block.

**Figure 30. Signal Path through the I/O Block**

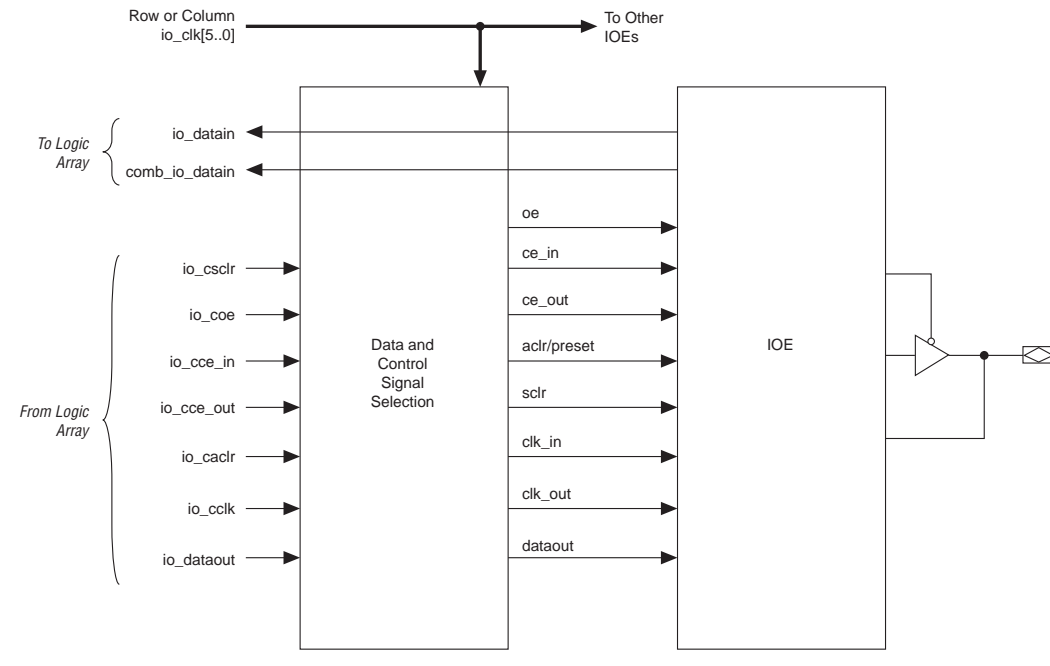

Each IOE contains its own control signal selection for the following control signals: `oe`, `ce_in`, `ce_out`, `aclr/preset`, `sclr/preset`, `clk_in`, and `clk_out`. Figure 31 illustrates the control signal selection.

**Figure 31. Control Signal Selection per IOE**

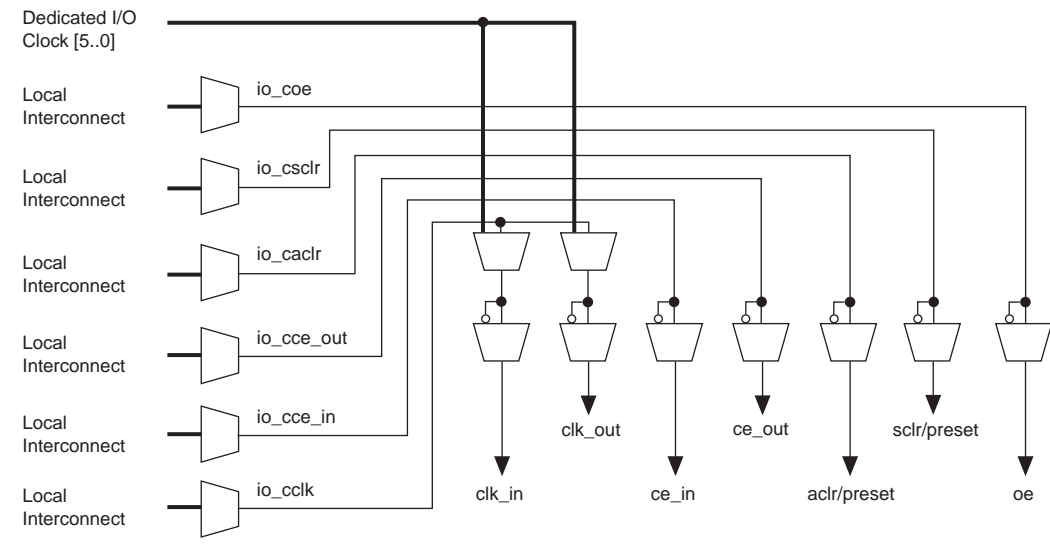

In normal bidirectional operation, the designer can use the input register for input data requiring fast setup times. The input register can have its own clock input and clock enable separate from the OE and output registers. The output register can be used for data requiring fast clock-to-output performance. The OE register is available for fast clock-to-output enable timing. The OE and output register share the same clock source and the same clock enable source from the local interconnect in the associated LAB, dedicated I/O clocks, or the column and row interconnects. [Figure 32](#) shows the IOE in bidirectional configuration.

**Figure 32. Cyclone IOE in Bidirectional I/O Configuration**

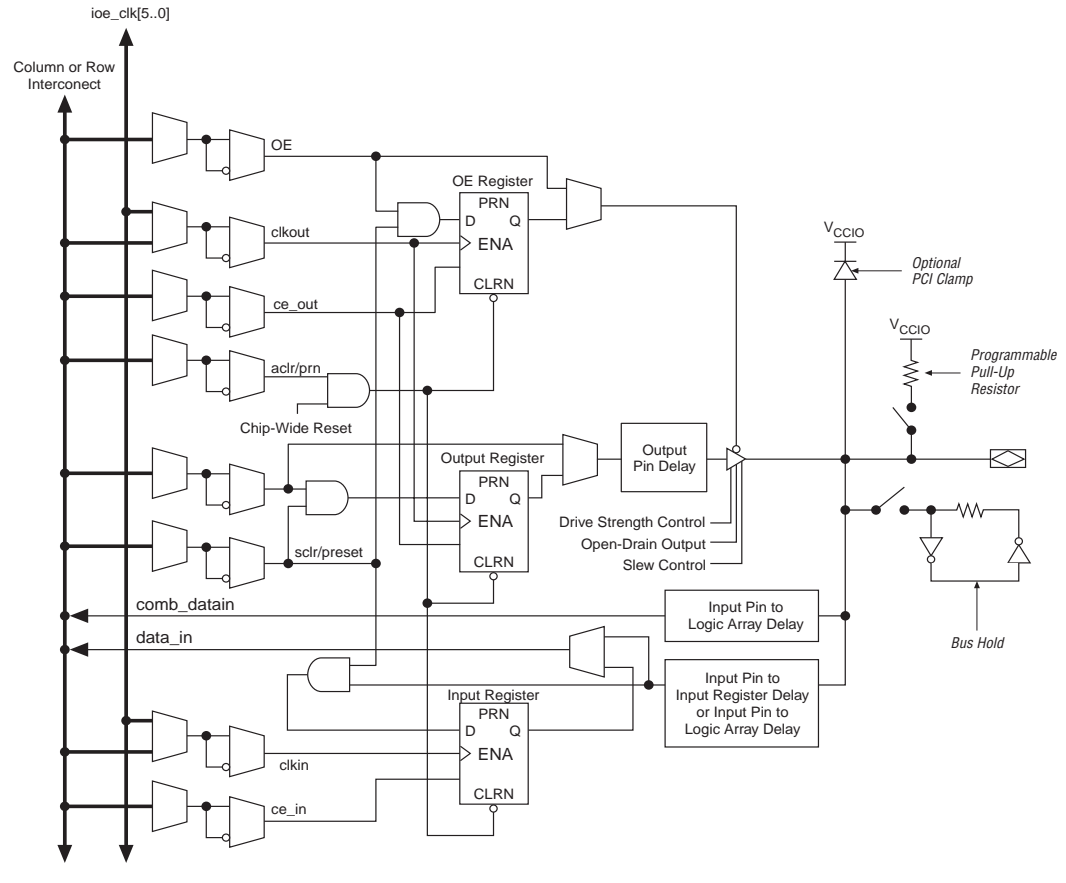

The Cyclone device IOE includes programmable delays to ensure zero hold times, minimize setup times, or increase clock to output times.

A path in which a pin directly drives a register may require a programmable delay to ensure zero hold time, whereas a path in which a pin drives a register through combinatorial logic may not require the delay. Programmable delays decrease input-pin-to-logic-array and IOE input register delays. The Quartus II Compiler can program these delays to automatically minimize setup time while providing a zero hold time. Programmable delays can increase the register-to-pin delays for output registers. Table 12 shows the programmable delays for Cyclone devices.

<b>Programmable Delays</b>	<b>Quartus II Logic Option</b>
Input pin to logic array delay	Decrease input delay to internal cells
Input pin to input register delay	Decrease input delay to input registers
Output pin delay	Increase delay to output pin

There are two paths in the IOE for a combinatorial input to reach the logic array. Each of the two paths can have a different delay. This allows the designer to adjust delays from the pin to internal LE registers that reside in two different areas of the device. The designer sets the two combinatorial input delays by selecting different delays for two different paths under the **Decrease input delay to internal cells** logic option in the Quartus II software. When the input signal requires two different delays for the combinatorial input, the input register in the IOE is no longer available.

The IOE registers in Cyclone devices share the same source for clear or preset. The designer can program preset or clear for each individual IOE. The designer can also program the registers to power up high or low after configuration is complete. If programmed to power up low, an asynchronous clear can control the registers. If programmed to power up high, an asynchronous preset can control the registers. This feature prevents the inadvertent activation of another device's active-low input upon power up. If one register in an IOE uses a preset or clear signal then all registers in the IOE must use that same signal if they require preset or clear. Additionally a synchronous reset signal is available to the designer for the IOE registers.

### External RAM Interfacing

Cyclone devices support DDR SDRAM and FCRAM interfaces at up to 133 MHz through dedicated circuitry.

## DDR SDRAM & FCRAM

Cyclone devices have dedicated circuitry for interfacing with DDR SDRAM. All I/O banks support DDR SDRAM and FCRAM I/O pins. However, the configuration input pins in bank 1 must operate at 2.5 V because the SSTL-2  $V_{CCIO}$  level is 2.5 V. Additionally, the configuration output pins (nSTATUS and CONF\_DONE) and all the JTAG pins in I/O bank 3 must operate at 2.5 V because the  $V_{CCIO}$  level of SSTL-2 is 2.5 V. I/O banks 1, 2, 3, and 4 support DQS signals with DQ bus modes of  $\times 8$ .

For  $\times 8$  mode, there are up to eight groups of programmable DQS and DQ pins, I/O banks 1, 2, 3, and 4 each have two groups in the 324-pin and 400-pin FineLine BGA packages. Each group consists of one DQS pin, a set of eight DQ pins, and one DM pin (see Figure 33). Each DQS pin drives the set of eight DQ pins within that group.

**Figure 33. Cyclone Device DQ & DQS Groups in  $\times 8$  Mode** *Note (1)*

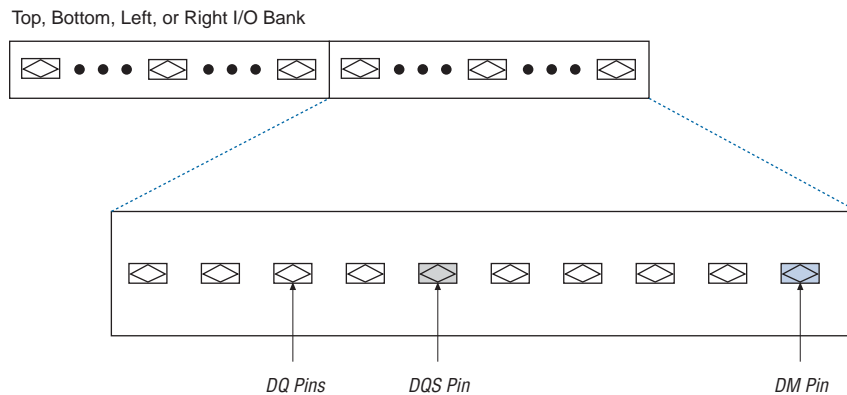

**Note to Figure 33:**

- (1) Each DQ group consists of one DQS pin, eight DQ pins, and one DM pin.

Table 13 shows the number of DQ pin groups per device.

<b>Table 13. DQ Pin Groups</b>			
<b>Device</b>	<b>Package</b>	<b>Number of ×8 DQ Pin Groups</b>	<b>Total DQ Pin Count</b>
EP1C3	100-pin TQFP (1)	3	24
	144-pin TQFP	4	32
EP1C4	324-pin FineLine BGA	8	64
	400-pin FineLine BGA	8	64
EP1C6	144-pin TQFP	4	32
	240-pin PQFP	4	32
	256-pin FineLine BGA	4	32
EP1C12	240-pin PQFP	4	32
	256-pin FineLine BGA	4	32
	324-pin FineLine BGA	8	64
EP1C20	324-pin FineLine BGA	8	64
	400-pin FineLine BGA	8	64

**Note to Table 13:**

- (1) EP1C3 devices in the 100-pin TQFP package do not have any DQ pin groups in I/O bank 1.

A programmable delay chain on each DQS pin allows for either a 90° phase shift (for DDR SDRAM), or a 72° phase shift (for FCRAM) which automatically center-aligns input DQS synchronization signals within the data window of their corresponding DQ data signals. The phase-shifted DQS signals drive the global clock network. This global DQS signal clocks DQ signals on internal LE registers.

These DQS delay elements combine with the PLL's clocking and phase shift ability to provide a complete hardware solution for interfacing to high-speed memory.

The clock phase shift allows the PLL to clock the DQ output enable and output paths. The designer should use the following guidelines to meet 133 MHz performance for DDR SDRAM and FCRAM interfaces:

- The DQS signal must be in the middle of the DQ group it clocks
- Resynchronize the incoming data to the logic array clock using successive LE registers or FIFO buffers
- LE registers must be placed in the LAB adjacent to the DQ I/O pin column it is fed by

Figure 34 illustrates DDR SDRAM and FCRAM interfacing from the I/O through the dedicated circuitry to the logic array.

**Figure 34. DDR SDRAM & FCRAM Interfacing**



## Programmable Drive Strength

The output buffer for each Cyclone device I/O pin has a programmable drive strength control for certain I/O standards. The LVTTTL and LVC MOS standards have several levels of drive strength that the designer can control. SSTL-3 class I and II, and SSTL-2 class I and II support a minimum setting, the lowest drive strength that guarantees the  $I_{OH}/I_{OL}$  of the standard. Using minimum settings provides signal slew rate control to reduce system noise and signal overshoot. Table 14 shows the possible settings for the I/O standards with drive strength control.

I/O Standard	$I_{OH}/I_{OL}$ Current Strength Setting (mA)
LVTTTL (3.3 V)	4
	8
	12
	16
	24
LVC MOS (3.3 V)	2
	4
	8
	12
LVTTTL (2.5 V)	2
	8
	12
	16
LVTTTL (1.8 V)	2
	8
	12
LVC MOS (1.5 V)	2
	4
	8

## Open-Drain Output

Cyclone devices provide an optional open-drain (equivalent to an open-collector) output for each I/O pin. This open-drain output enables the device to provide system-level control signals (e.g., interrupt and write-enable signals) that can be asserted by any of several devices.

## Slew-Rate Control

The output buffer for each Cyclone device I/O pin has a programmable output slew-rate control that can be configured for low noise or high-speed performance. A faster slew rate provides high-speed transitions for high-performance systems. However, these fast transitions may introduce noise transients into the system. A slow slew rate reduces system noise, but adds a nominal delay to rising and falling edges. Each I/O pin has an individual slew-rate control, allowing the designer to specify the slew rate on a pin-by-pin basis. The slew-rate control affects both the rising and falling edges.

## Bus Hold

Each Cyclone device I/O pin provides an optional bus-hold feature. The bus-hold circuitry can hold the signal on an I/O pin at its last-driven state. Since the bus-hold feature holds the last-driven state of the pin until the next input signal is present, an external pull-up or pull-down resistor is not necessary to hold a signal level when the bus is tri-stated.

The bus-hold circuitry also pulls undriven pins away from the input threshold voltage where noise can cause unintended high-frequency switching. The designer can select this feature individually for each I/O pin. The bus-hold output will drive no higher than  $V_{CCIO}$  to prevent overdriving signals. If the bus-hold feature is enabled, the device cannot use the programmable pull-up option. Disable the bus-hold feature when the I/O pin is configured for differential signals.

The bus-hold circuitry uses a resistor with a nominal resistance (RBH) of approximately 7 k $\Omega$  to pull the signal level to the last-driven state. [Table 37 on page 72](#) gives the specific sustaining current for each  $V_{CCIO}$  voltage level driven through this resistor and overdrive current used to identify the next-driven input level.

The bus-hold circuitry is only active after configuration. When going into user mode, the bus-hold circuit captures the value on the pin present at the end of configuration.

## Programmable Pull-Up Resistor

Each Cyclone device I/O pin provides an optional programmable pull-up resistor during user mode. If the designer enables this feature for an I/O pin, the pull-up resistor (typically 25 k $\Omega$ ) holds the output to the  $V_{CCIO}$  level of the output pin's bank.

## Advanced I/O Standard Support

Cyclone device IOEs support the following I/O standards:

- 3.3-V LVTTTL/LVCMOS
- 2.5-V LVTTTL/LVCMOS
- 1.8-V LVTTTL/LVCMOS
- 1.5-V LVCMOS
- 3.3-V PCI
- LVDS
- SSTL-2 class I and II
- SSTL-3 class I and II
- Differential SSTL-2 class II (on output clocks only)

Table 15 describes the I/O standards supported by Cyclone devices.

I/O Standard	Type	Input Reference Voltage ( $V_{REF}$ ) (V)	Output Supply Voltage ( $V_{CCIO}$ ) (V)	Board Termination Voltage ( $V_{TT}$ ) (V)
3.3-V LVTTTL/LVCMOS	Single-ended	N/A	3.3	N/A
2.5-V LVTTTL/LVCMOS	Single-ended	N/A	2.5	N/A
1.8-V LVTTTL/LVCMOS	Single-ended	N/A	1.8	N/A
1.5-V LVCMOS	Single-ended	N/A	1.5	N/A
3.3-V PCI (1)	Single-ended	N/A	3.3	N/A
LVDS (2)	Differential	N/A	2.5	N/A
SSTL-2 class I and II	Voltage-referenced	1.25	2.5	1.25
SSTL-3 class I and II	Voltage-referenced	1.5	3.3	1.5
Differential SSTL-2 (3)	Differential	1.25	2.5	1.25

**Notes to Table 15:**

- (1) EP1C3 devices do not support PCI.
- (2) EP1C3 devices in the 100-pin TQFP package do not support the LVDS I/O standard.
- (3) This I/O standard is only available on output clock pins (PLL\_OUT pins).

Cyclone devices contain four I/O banks, as shown in Figure 35. I/O banks 1 and 3 support all the I/O standards listed in Table 15. I/O banks 2 and 4 support all the I/O standards listed in Table 15 except the 3.3-V PCI standard. I/O banks 2 and 4 contain dual-purpose DQS, DQ, and DM pins to support a DDR SDRAM or FCRAM interface. I/O bank 1 can also support a DDR SDRAM or FCRAM interface, however, the configuration input pins in I/O bank 1 must operate at 2.5 V. I/O bank 3 can also support a DDR SDRAM or FCRAM interface, however, all the JTAG pins in I/O bank 3 must operate at 2.5 V.

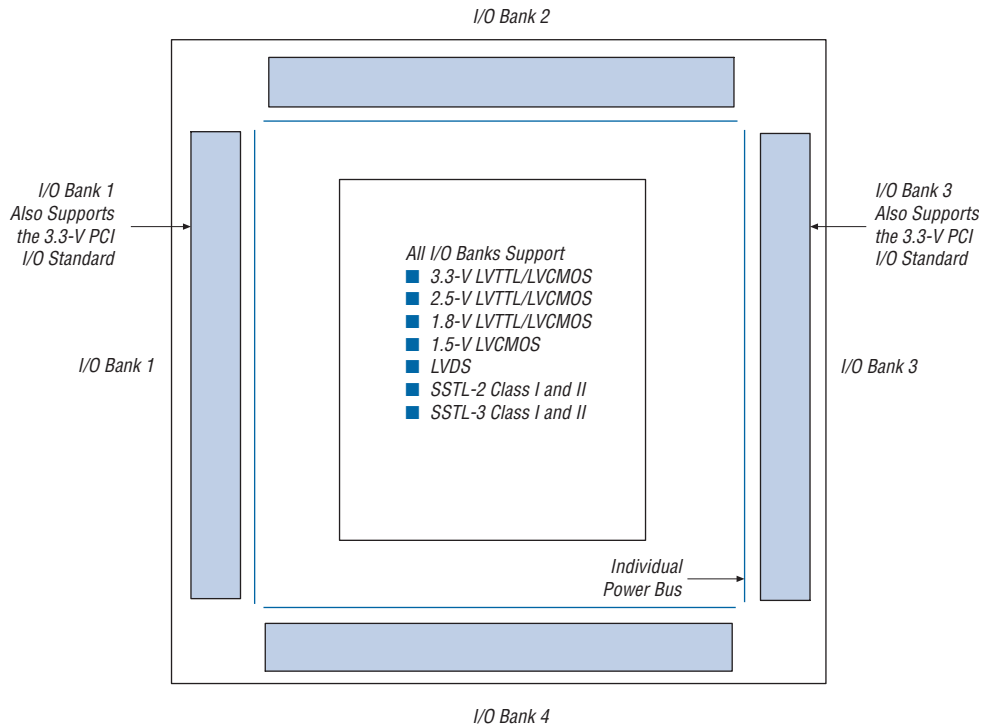
**Figure 35. Cyclone I/O Banks** Notes (1), (2)**Notes to Figure 35:**

- (1) Figure 35 is a top view of the silicon die.
- (2) Figure 35 is a graphic representation only. Refer to the pin list and the Quartus II software for exact pin locations.

Each I/O bank has its own  $V_{CCIO}$  pins. A single device can support 1.5-V, 1.8-V, 2.5-V, and 3.3-V interfaces; each individual bank can support a different standard with different I/O voltages. Each bank also has dual-purpose  $V_{REF}$  pins to support any one of the voltage-referenced standards (e.g., SSTL-3) independently. If an I/O bank does not use voltage-referenced standards, the  $V_{REF}$  pins are available as user I/O pins.

Each I/O bank can support multiple standards with the same  $V_{CCIO}$  for input and output pins. For example, when  $V_{CCIO}$  is 3.3 V, a bank can support LVTTTL, LVCMOS, 3.3-V PCI, and SSTL-3 for inputs and outputs.

## LVDS I/O Pins

A subset of pins in all four I/O banks supports LVDS interfacing. These dual-purpose LVDS pins require an external-resistor network at the transmitter channels in addition to 100- $\Omega$  termination resistors on receiver channels. These pins do not contain dedicated serialization or deserialization circuitry; therefore, internal logic performs serialization and deserialization functions.

Table 16 shows the total number of supported LVDS channels per device density.

Device	Pin Count	Number of LVDS Channels
EP1C3	100	(1)
	144	34
EP1C4	324	103
	400	129
EP1C6	144	29
	240	72
	256	72
EP1C12	240	66
	256	72
	324	103
EP1C20	324	95
	400	129

**Note to Table 16:**

- (1) EP1C3 devices in the 100-pin TQFP package do not support the LVDS I/O standard.

## MultiVolt I/O Interface

The Cyclone architecture supports the MultiVolt I/O interface feature, which allows Cyclone devices in all packages to interface with systems of different supply voltages. The devices have one set of  $V_{CC}$  pins for internal operation and input buffers ( $V_{CCINT}$ ), and four sets for I/O output drivers ( $V_{CCIO}$ ).

The Cyclone  $V_{CCINT}$  pins must always be connected to a 1.5-V power supply. If the  $V_{CCINT}$  level is 1.5 V, then input pins are 1.5-V, 1.8-V, 2.5-V, and 3.3-V tolerant. The  $V_{CCIO}$  pins can be connected to either a 1.5-V, 1.8-V, 2.5-V, or 3.3-V power supply, depending on the output requirements. The output levels are compatible with systems of the same voltage as the power supply (i.e., when  $V_{CCIO}$  pins are connected to a 1.5-V power supply, the output levels are compatible with 1.5-V systems). When  $V_{CCIO}$  pins are connected to a 3.3-V power supply, the output high is 3.3 V and is compatible with 3.3-V or 5.0-V systems. Table 17 summarizes Cyclone MultiVolt I/O support.

$V_{CCIO}$ (V)	Input Signal					Output Signal				
	1.5 V	1.8 V	2.5 V	3.3 V	5.0 V	1.5 V	1.8 V	2.5 V	3.3 V	5.0 V
1.5	✓	✓	✓ (2)	✓ (2)		✓				
1.8		✓	✓	✓		✓ (3)	✓			
2.5			✓	✓		✓ (5)	✓ (5)	✓		
3.3			✓ (4)	✓	✓ (6)	✓ (7)	✓ (7)	✓ (7)	✓	✓ (8)

**Notes to Table 17:**

- (1) The PCI clamping diode must be disabled to drive an input with voltages higher than  $V_{CCIO}$ .
- (2) When  $V_{CCIO} = 1.5$  V and a 2.5- or 3.3-V input signal feeds an input pin, higher pin leakage current is expected.
- (3) When  $V_{CCIO} = 1.8$  V, a Cyclone device can drive a 1.5-V device with 1.8-V tolerant inputs.
- (4) When  $V_{CCIO} = 3.3$  V and a 2.5-V input signal feeds an input pin, the  $V_{CCIO}$  supply current will be slightly larger than expected.
- (5) When  $V_{CCIO} = 2.5$  V, a Cyclone device can drive a 1.5-V or 1.8-V device with 2.5-V tolerant inputs.
- (6) Cyclone devices can be 5.0-V tolerant with the use of an external resistor and the internal PCI clamp diode.
- (7) When  $V_{CCIO} = 3.3$  V, a Cyclone device can drive a 1.5-V, 1.8-V, or 2.5-V device with 3.3-V tolerant inputs.
- (8) When  $V_{CCIO} = 3.3$  V, a Cyclone device can drive a device with 5.0-V LVTTTL inputs but not 5.0-V LVCMOS inputs.

## Power Sequencing & Hot Socketing

Because Cyclone devices can be used in a mixed-voltage environment, they have been designed specifically to tolerate any possible power-up sequence. Therefore, the  $V_{CCIO}$  and  $V_{CCINT}$  power supplies may be powered in any order.

Signals can be driven into Cyclone devices before and during power up without damaging the device. In addition, Cyclone devices do not drive out during power up. Once operating conditions are reached and the device is configured, Cyclone devices operate as specified by the user.

## IEEE Std. 1149.1 (JTAG) Boundary Scan Support

All Cyclone devices provide JTAG BST circuitry that complies with the IEEE Std. 1149.1a-1990 specification. JTAG boundary-scan testing can be performed either before or after, but not during configuration. Cyclone devices can also use the JTAG port for configuration together with either the Quartus II software or hardware using either Jam Files (.jam) or Jam Byte-Code Files (.jbc).

Cyclone devices support reconfiguring the I/O standard settings on the IOE through the JTAG BST chain. The JTAG chain can update the I/O standard for all input and output pins any time before or during user mode. Designers can use this ability for JTAG testing before configuration when some of the Cyclone pins drive or receive from other devices on the board using voltage-referenced standards. Since the Cyclone device might not be configured before JTAG testing, the I/O pins might not be configured for appropriate electrical standards for chip-to-chip communication. Programming those I/O standards via JTAG allows designers to fully test I/O connection to other devices.

The JTAG pins support 1.5-V/1.8-V or 2.5-V/3.3-V I/O standards. The TDO pin voltage is determined by the  $V_{CCIO}$  of the bank where it resides. The bank  $V_{CCIO}$  selects whether the JTAG inputs are 1.5-V, 1.8-V, 2.5-V, or 3.3-V compatible.

Cyclone devices also use the JTAG port to monitor the operation of the device with the SignalTap<sup>®</sup> II embedded logic analyzer. Cyclone devices support the JTAG instructions shown in [Table 18](#).

<b>Table 18. Cyclone JTAG Instructions</b>		
<b>JTAG Instruction</b>	<b>Instruction Code</b>	<b>Description</b>
SAMPLE/PRELOAD	00 0000 0101	Allows a snapshot of signals at the device pins to be captured and examined during normal device operation, and permits an initial data pattern to be output at the device pins. Also used by the SignalTap II embedded logic analyzer.
EXTEST (1)	00 0000 0000	Allows the external circuitry and board-level interconnects to be tested by forcing a test pattern at the output pins and capturing test results at the input pins.
BYPASS	11 1111 1111	Places the 1-bit bypass register between the TDI and TDO pins, which allows the BST data to pass synchronously through selected devices to adjacent devices during normal device operation.
USERCODE	00 0000 0111	Selects the 32-bit USERCODE register and places it between the TDI and TDO pins, allowing the USERCODE to be serially shifted out of TDO.
IDCODE	00 0000 0110	Selects the IDCODE register and places it between TDI and TDO, allowing the IDCODE to be serially shifted out of TDO.
HIGHZ (1)	00 0000 1011	Places the 1-bit bypass register between the TDI and TDO pins, which allows the BST data to pass synchronously through selected devices to adjacent devices during normal device operation, while tri-stating all of the I/O pins.
CLAMP (1)	00 0000 1010	Places the 1-bit bypass register between the TDI and TDO pins, which allows the BST data to pass synchronously through selected devices to adjacent devices during normal device operation while holding I/O pins to a state defined by the data in the boundary-scan register.
ICR instructions		Used when configuring a Cyclone device via the JTAG port with a MasterBlaster™ or ByteBlasterMV™ download cable, or when using a Jam File or Jam Byte-Code File via an embedded processor.
PULSE_NCONFIG	00 0000 0001	Emulates pulsing the nCONFIG pin low to trigger reconfiguration even though the physical pin is unaffected.
CONFIG_IO	00 0000 1101	Allows configuration of I/O standards through the JTAG chain for JTAG testing. Can be executed before, after, or during configuration. Stops configuration if executed during configuration. Once issued, the CONFIG_IO instruction will hold nSTATUS low to reset the configuration device. nSTATUS is held low until the device is reconfigured.
SignalTap II instructions		Monitors internal device operation with the SignalTap II embedded logic analyzer.

**Note to Table 18:**

(1) Bus hold and weak pull-up resistor features override the high-impedance state of HIGHZ, CLAMP, and EXTEST.

The Cyclone device instruction register length is 10 bits and the USERCODE register length is 32 bits. Tables 19 and 20 show the boundary-scan register length and device IDCODE information for Cyclone devices.

**Table 19. Cyclone Boundary-Scan Register Length**

Device	Boundary-Scan Register Length
EP1C3	339
EP1C4	930
EP1C6	582
EP1C12	774
EP1C20	930

**Table 20. 32-Bit Cyclone Device IDCODE**

Device	IDCODE (32 Bits) (1)			
	Version (4 Bits)	Part Number (16 Bits)	Manufacturer Identity (11 Bits)	LSB (1 Bit) (2)
EP1C3	0000	0010 0000 1000 0001	000 0110 1110	1
EP1C4	0000	0010 0000 1000 0101	000 0110 1110	1
EP1C6	0000	0010 0000 1000 0010	000 0110 1110	1
EP1C12	0000	0010 0000 1000 0011	000 0110 1110	1
EP1C20	0000	0010 0000 1000 0100	000 0110 1110	1

**Notes to Table 20:**

- (1) The most significant bit (MSB) is on the left.
- (2) The IDCODE's least significant bit (LSB) is always 1.

Figure 36 shows the timing requirements for the JTAG signals.

**Figure 36. Cyclone JTAG Waveforms**

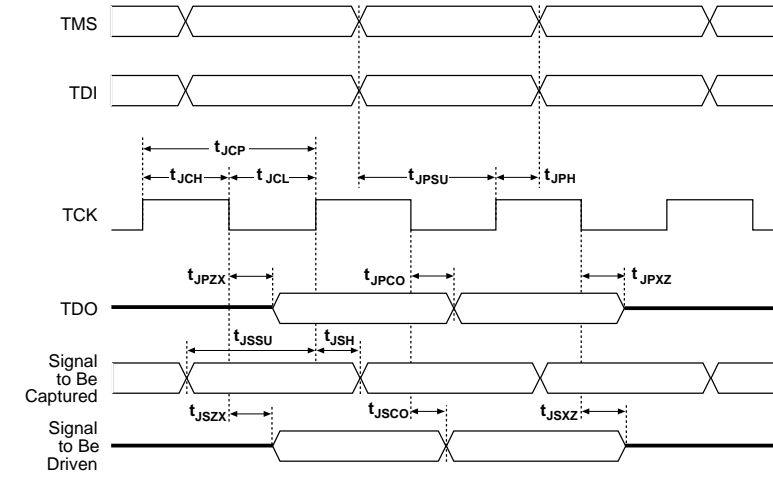

Table 21 shows the JTAG timing parameters and values for Cyclone devices.

Symbol	Parameter	Min	Max	Unit
$t_{JCP}$	TCK clock period	100		ns
$t_{JCH}$	TCK clock high time	50		ns
$t_{JCL}$	TCK clock low time	50		ns
$t_{JPSU}$	JTAG port setup time	20		ns
$t_{JPH}$	JTAG port hold time	45		ns
$t_{JPCO}$	JTAG port clock to output		25	ns
$t_{JPZX}$	JTAG port high impedance to valid output		25	ns
$t_{JPXZ}$	JTAG port valid output to high impedance		25	ns
$t_{JSSU}$	Capture register setup time	20		ns
$t_{JSH}$	Capture register hold time	45		ns
$t_{JSCO}$	Update register clock to output		35	ns
$t_{JSZX}$	Update register high impedance to valid output		35	ns
$t_{JSXZ}$	Update register valid output to high impedance		35	ns



For more information on JTAG, see the following documents:

- [Application Note 39 \(IEEE Std. 1149.1 \(JTAG\) Boundary-Scan Testing in Altera Devices\)](#)
- [Jam Programming & Test Language Specification](#)

## SignalTap II Embedded Logic Analyzer

Cyclone devices feature the SignalTap II embedded logic analyzer, which monitors design operation over a period of time through the IEEE Std. 1149.1 (JTAG) circuitry. A designer can analyze internal logic at speed without bringing internal signals to the I/O pins. This feature is particularly important for advanced packages, such as FineLine BGA packages, because it can be difficult to add a connection to a pin during the debugging process after a board is designed and manufactured.

## Configuration

The logic, circuitry, and interconnects in the Cyclone architecture are configured with CMOS SRAM elements. Cyclone devices are reconfigurable and are 100% tested prior to shipment. As a result, the designer does not have to generate test vectors for fault coverage purposes, and can instead focus on simulation and design verification. In addition, the designer does not need to manage inventories of different ASIC designs. Cyclone devices can be configured on the board for the specific functionality required.

Cyclone devices are configured at system power-up with data stored in an Altera configuration device or provided by a system controller. The Cyclone device's optimized interface allows the device to act as controller in an active serial configuration scheme with the new low-cost serial configuration device. Cyclone devices can be configured in under 120 ms using serial data at 20 MHz. The serial configuration device can be programmed via the ByteBlaster II download cable, the Altera Programming Unit (APU), or third-party programmers.

In addition to the new low-cost serial configuration device, Altera offers in-system programmability (ISP)-capable configuration devices that can configure Cyclone devices via a serial data stream. The interface also enables microprocessors to treat Cyclone devices as memory and configure them by writing to a virtual memory location, making reconfiguration easy. After a Cyclone device has been configured, it can be reconfigured in-circuit by resetting the device and loading new data. Real-time changes can be made during system operation, enabling innovative reconfigurable computing applications.

## Operating Modes

The Cyclone architecture uses SRAM configuration elements that require configuration data to be loaded each time the circuit powers up. The process of physically loading the SRAM data into the device is called configuration. During initialization, which occurs immediately after configuration, the device resets registers, enables I/O pins, and begins to operate as a logic device. Together, the configuration and initialization processes are called command mode. Normal device operation is called user mode.

SRAM configuration elements allow Cyclone devices to be reconfigured in-circuit by loading new configuration data into the device. With real-time reconfiguration, the device is forced into command mode with a device pin. The configuration process loads different configuration data, reinitializes the device, and resumes user-mode operation. Designers can perform in-field upgrades by distributing new configuration files either within the system or remotely.

A built-in weak pull-up resistor pulls all user I/O pins to  $V_{CCIO}$  before and during device configuration.

The configuration pins support 1.5-V/1.8-V or 2.5-V/3.3-V I/O standards. The voltage level of the configuration output pins is determined by the  $V_{CCIO}$  of the bank where the pins reside. The bank  $V_{CCIO}$  selects whether the configuration inputs are 1.5-V, 1.8-V, 2.5-V, or 3.3-V compatible.

## Configuration Schemes

Designers can load the configuration data for a Cyclone device with one of three configuration schemes (see [Table 22](#)), chosen on the basis of the target application. Designers can use a configuration device, intelligent controller, or the JTAG port to configure a Cyclone device. A low-cost configuration device can automatically configure a Cyclone device at system power-up.

Multiple Cyclone devices can be configured in any of the three configuration schemes by connecting the configuration enable ( $nCE$ ) and configuration enable output ( $nCEO$ ) pins on each device.

**Table 22. Data Sources for Configuration**

Configuration Scheme	Data Source
Active serial	Low-cost serial configuration device
Passive serial (PS)	Enhanced or EPC2 configuration device, MasterBlaster or ByteBlasterMV download cable, or serial data source
JTAG	MasterBlaster or ByteBlasterMV download cable or a microprocessor with a Jam or JBC file

## Operating Conditions

Cyclone devices are offered in both commercial and industrial grades. However, industrial-grade devices may have limited speed-grade availability.

Tables 23 through 38 provide information on absolute maximum ratings, recommended operating conditions, DC operating conditions, and capacitance for Cyclone devices.

**Table 23. Cyclone Device Absolute Maximum Ratings** Notes (1), (2)

Symbol	Parameter	Conditions	Minimum	Maximum	Unit
$V_{CCINT}$	Supply voltage	With respect to ground (3)	-0.5	2.4	V
$V_{CCIO}$			-0.5	4.6	V
$V_I$	DC input voltage		-0.5	4.6	V
$I_{OUT}$	DC output current, per pin		-25	25	mA
$T_{STG}$	Storage temperature	No bias	-65	150	°C
$T_{AMB}$	Ambient temperature	Under bias	-65	135	°C
$T_J$	Junction temperature	BGA packages under bias		135	°C

Symbol	Parameter	Conditions	Minimum	Maximum	Unit
V <sub>CCINT</sub>	Supply voltage for internal logic and input buffers	(4)	1.425	1.575	V
V <sub>CCIO</sub>	Supply voltage for output buffers, 3.3-V operation	(4)	3.00	3.60	V
	Supply voltage for output buffers, 2.5-V operation	(4)	2.375	2.625	V
	Supply voltage for output buffers, 1.8-V operation	(4)	1.71	1.89	V
	Supply voltage for output buffers, 1.5-V operation	(4)	1.4	1.6	V
V <sub>I</sub>	Input voltage	(3), (5)	-0.5	4.1	V
V <sub>O</sub>	Output voltage		0	V <sub>CCIO</sub>	V
T <sub>J</sub>	Operating junction temperature	For commercial use	0	85	°C
		For industrial use	-40	100	°C
t <sub>R</sub>	Input rise time			40	ns
t <sub>F</sub>	Input fall time			40	ns

Symbol	Parameter	Conditions	Minimum	Typical	Maximum	Unit
I <sub>I</sub>	Input pin leakage current	V <sub>I</sub> = V <sub>CCIOmax</sub> to 0 V (7)	-10		10	μA
I <sub>OZ</sub>	Tri-stated I/O pin leakage current	V <sub>O</sub> = V <sub>CCIOmax</sub> to 0 V (7)	-10		10	μA
I <sub>CC0</sub>	V <sub>CC</sub> supply current (standby) (All M4K blocks in power-down mode)	V <sub>I</sub> = ground, no load, no toggling inputs		10		mA
R <sub>CONF</sub>	Value of I/O pin pull-up resistor before and during configuration	V <sub>CCIO</sub> = 3.0 V (8)	20		50	kΩ
		V <sub>CCIO</sub> = 2.375 V (8)	30		80	kΩ
		V <sub>CCIO</sub> = 1.71 V (8)	60		150	kΩ

Symbol	Parameter	Conditions	Minimum	Maximum	Unit
$V_{CCIO}$	Output supply voltage		3.0	3.6	V
$V_{IH}$	High-level input voltage		1.7	4.1	V
$V_{IL}$	Low-level input voltage		-0.5	0.7	V
$V_{OH}$	High-level output voltage	$I_{OH} = -4$ to $-24$ mA (9)	2.4		V
$V_{OL}$	Low-level output voltage	$I_{OL} = 4$ to $24$ mA (9)		0.45	V

Symbol	Parameter	Conditions	Minimum	Maximum	Unit
$V_{CCIO}$	Output supply voltage		3.0	3.6	V
$V_{IH}$	High-level input voltage		1.7	4.1	V
$V_{IL}$	Low-level input voltage		-0.5	0.7	V
$V_{OH}$	High-level output voltage	$V_{CCIO} = 3.0$ , $I_{OH} = -0.1$ mA	$V_{CCIO} - 0.2$		V
$V_{OL}$	Low-level output voltage	$V_{CCIO} = 3.0$ , $I_{OL} = 0.1$ mA		0.2	V

Symbol	Parameter	Conditions	Minimum	Maximum	Unit
$V_{CCIO}$	Output supply voltage		2.375	2.625	V
$V_{IH}$	High-level input voltage		1.7	4.1	V
$V_{IL}$	Low-level input voltage		-0.5	0.7	V
$V_{OH}$	High-level output voltage	$I_{OH} = -0.1$ mA	2.1		V
		$I_{OH} = -1$ mA	2.0		V
		$I_{OH} = -2$ to $-16$ mA (9)	1.7		V
$V_{OL}$	Low-level output voltage	$I_{OL} = 0.1$ mA		0.2	V
		$I_{OH} = 1$ mA		0.4	V
		$I_{OH} = 2$ to $16$ mA (9)		0.7	V

**Table 29. 1.8-V I/O Specifications**

Symbol	Parameter	Conditions	Minimum	Maximum	Unit
$V_{CCIO}$	Output supply voltage		1.65	1.95	V
$V_{IH}$	High-level input voltage		$0.65 \times V_{CCIO}$	2.25	V
$V_{IL}$	Low-level input voltage		-0.3	$0.35 \times V_{CCIO}$	V
$V_{OH}$	High-level output voltage	$I_{OH} = -2$ to $-8$ mA (9)	$V_{CCIO} - 0.45$		V
$V_{OL}$	Low-level output voltage	$I_{OL} = 2$ to $8$ mA (9)		0.45	V

**Table 30. 1.5-V I/O Specifications**

Symbol	Parameter	Conditions	Minimum	Maximum	Unit
$V_{CCIO}$	Output supply voltage		1.4	1.6	V
$V_{IH}$	High-level input voltage		$0.65 \times V_{CCIO}$	$V_{CCIO} + 0.3$	V
$V_{IL}$	Low-level input voltage		-0.3	$0.35 \times V_{CCIO}$	V
$V_{OH}$	High-level output voltage	$I_{OH} = -2$ mA (9)	$0.75 \times V_{CCIO}$		V
$V_{OL}$	Low-level output voltage	$I_{OL} = 2$ mA (9)		$0.25 \times V_{CCIO}$	V

**Table 31. 2.5-V LVDS I/O Specifications** Note (10)

Symbol	Parameter	Conditions	Minimum	Typical	Maximum	Unit
$V_{CCIO}$	I/O supply voltage		2.375	2.5	2.625	V
$V_{OD}$	Differential output voltage	$R_L = 100 \Omega$	250		550	mV
$\Delta V_{OD}$	Change in $V_{OD}$ between high and low	$R_L = 100 \Omega$			50	mV
$V_{OS}$	Output offset voltage	$R_L = 100 \Omega$	1.125	1.25	1.375	V
$\Delta V_{OS}$	Change in $V_{OS}$ between high and low	$R_L = 100 \Omega$			50	mV
$V_{TH}$	Differential input threshold	$V_{CM} = 1.2$ V	-100		100	mV
$V_{IN}$	Receiver input voltage range		0.0		2.4	V
$R_L$	Receiver differential input resistor		90	100	110	$\Omega$

Symbol	Parameter	Conditions	Minimum	Typical	Maximum	Unit
V <sub>CCIO</sub>	Output supply voltage		3.0	3.3	3.6	V
V <sub>IH</sub>	High-level input voltage		0.5 × V <sub>CCIO</sub>		V <sub>CCIO</sub> + 0.5	V
V <sub>IL</sub>	Low-level input voltage		-0.5		0.3 × V <sub>CCIO</sub>	V
V <sub>OH</sub>	High-level output voltage	I <sub>OUT</sub> = -500 μA	0.9 × V <sub>CCIO</sub>			V
V <sub>OL</sub>	Low-level output voltage	I <sub>OUT</sub> = 1,500 μA			0.1 × V <sub>CCIO</sub>	V

Symbol	Parameter	Conditions	Minimum	Typical	Maximum	Unit
V <sub>CCIO</sub>	Output supply voltage		2.375	2.5	2.625	V
V <sub>TT</sub>	Termination voltage		V <sub>REF</sub> - 0.04	V <sub>REF</sub>	V <sub>REF</sub> + 0.04	V
V <sub>REF</sub>	Reference voltage		1.15	1.25	1.35	V
V <sub>IH</sub>	High-level input voltage		V <sub>REF</sub> + 0.18		3.0	V
V <sub>IL</sub>	Low-level input voltage		-0.3		V <sub>REF</sub> - 0.18	V
V <sub>OH</sub>	High-level output voltage	I <sub>OH</sub> = -8.1 mA (9)	V <sub>TT</sub> + 0.57			V
V <sub>OL</sub>	Low-level output voltage	I <sub>OL</sub> = 8.1 mA (9)			V <sub>TT</sub> - 0.57	V

Symbol	Parameter	Conditions	Minimum	Typical	Maximum	Unit
V <sub>CCIO</sub>	Output supply voltage		2.3	2.5	2.7	V
V <sub>TT</sub>	Termination voltage		V <sub>REF</sub> - 0.04	V <sub>REF</sub>	V <sub>REF</sub> + 0.04	V
V <sub>REF</sub>	Reference voltage		1.15	1.25	1.35	V
V <sub>IH</sub>	High-level input voltage		V <sub>REF</sub> + 0.18		V <sub>CCIO</sub> + 0.3	V
V <sub>IL</sub>	Low-level input voltage		-0.3		V <sub>REF</sub> - 0.18	V
V <sub>OH</sub>	High-level output voltage	I <sub>OH</sub> = -16.4 mA (9)	V <sub>TT</sub> + 0.76			V
V <sub>OL</sub>	Low-level output voltage	I <sub>OL</sub> = 16.4 mA (9)			V <sub>TT</sub> - 0.76	V

**Table 35. SSTL-3 Class I Specifications**

Symbol	Parameter	Conditions	Minimum	Typical	Maximum	Unit
V <sub>CCIO</sub>	Output supply voltage		3.0	3.3	3.6	V
V <sub>TT</sub>	Termination voltage		V <sub>REF</sub> - 0.05	V <sub>REF</sub>	V <sub>REF</sub> + 0.05	V
V <sub>REF</sub>	Reference voltage		1.3	1.5	1.7	V
V <sub>IH</sub>	High-level input voltage		V <sub>REF</sub> + 0.2		V <sub>CCIO</sub> + 0.3	V
V <sub>IL</sub>	Low-level input voltage		-0.3		V <sub>REF</sub> - 0.2	V
V <sub>OH</sub>	High-level output voltage	I <sub>OH</sub> = -8 mA (9)	V <sub>TT</sub> + 0.6			V
V <sub>OL</sub>	Low-level output voltage	I <sub>OL</sub> = 8 mA (9)			V <sub>TT</sub> - 0.6	V

**Table 36. SSTL-3 Class II Specifications**

Symbol	Parameter	Conditions	Minimum	Typical	Maximum	Unit
V <sub>CCIO</sub>	Output supply voltage		3.0	3.3	3.6	V
V <sub>TT</sub>	Termination voltage		V <sub>REF</sub> - 0.05	V <sub>REF</sub>	V <sub>REF</sub> + 0.05	V
V <sub>REF</sub>	Reference voltage		1.3	1.5	1.7	V
V <sub>IH</sub>	High-level input voltage		V <sub>REF</sub> + 0.2		V <sub>CCIO</sub> + 0.3	V
V <sub>IL</sub>	Low-level input voltage		-0.3		V <sub>REF</sub> - 0.2	V
V <sub>OH</sub>	High-level output voltage	I <sub>OH</sub> = -16 mA (9)	V <sub>TT</sub> + 0.8			V
V <sub>OL</sub>	Low-level output voltage	I <sub>OL</sub> = 16 mA (9)			V <sub>TT</sub> - 0.8	V

**Table 37. Bus Hold Parameters**

Parameter	Conditions	V <sub>CCIO</sub> Level								Unit
		1.5 V		1.8 V		2.5 V		3.3 V		
		Min	Max	Min	Max	Min	Max	Min	Max	
Low sustaining current	V <sub>IN</sub> > V <sub>IL</sub> (maximum)			30		50		70		μA
High sustaining current	V <sub>IN</sub> < V <sub>IH</sub> (minimum)			-30		-50		-70		μA
Low overdrive current	0 V < V <sub>IN</sub> < V <sub>CCIO</sub>				200		300		500	μA
High overdrive current	0 V < V <sub>IN</sub> < V <sub>CCIO</sub>				-200		-300		-500	μA

<b>Table 38. Cyclone Device Capacitance</b> <i>Note (11)</i>			
<b>Symbol</b>	<b>Parameter</b>	<b>Typical</b>	<b>Unit</b>
C <sub>IO</sub>	Input capacitance for user I/O pin	4.0	pF
C <sub>LVDS</sub>	Input capacitance for dual-purpose LVDS/user I/O pin	4.7	pF
C <sub>VREF</sub>	Input capacitance for dual-purpose V <sub>REF</sub> /user I/O pin.	12.0	pF
C <sub>DPCLK</sub>	Input capacitance for dual-purpose DPCLK/user I/O pin.	4.4	pF
C <sub>CLK</sub>	Input capacitance for CLK pin.	4.7	pF

**Notes to Tables 23 – 38:**

- (1) See the *Operating Requirements for Altera Devices Data Sheet*.
- (2) Conditions beyond those listed in Table 23 may cause permanent damage to a device. Additionally, device operation at the absolute maximum ratings for extended periods of time may have adverse affects on the device.
- (3) Minimum DC input is -0.5 V. During transitions, the inputs may undershoot to -0.5 V or overshoot to 4.6 V for input currents less than 100 mA and periods shorter than 20 ns.
- (4) Maximum V<sub>CC</sub> rise time is 100 ms, and V<sub>CC</sub> must rise monotonically.
- (5) All pins, including dedicated inputs, clock, I/O, and JTAG pins, may be driven before V<sub>CCINT</sub> and V<sub>CCIO</sub> are powered.
- (6) Typical values are for T<sub>A</sub> = 25° C, V<sub>CCINT</sub> = 1.5 V, and V<sub>CCIO</sub> = 1.5 V, 1.8 V, 2.5 V, and 3.3 V.
- (7) This value is specified for normal device operation. The value may vary during power-up. This applies for all V<sub>CCIO</sub> settings (3.3, 2.5, 1.8, and 1.5 V).
- (8) Pin pull-up resistance values will lower if an external source drives the pin higher than V<sub>CCIO</sub>.
- (9) Drive strength is programmable according to values in Table 14 on page 55.
- (10) The Cyclone LVDS interface requires a resistor network outside of the transmitter channels.
- (11) Capacitance is sample-tested only. Capacitance is measured using time-domain reflections (TDR). Measurement accuracy is within ±0.5 pF.

## Power Consumption

Designers can use the Altera web power calculator to estimate the device power.

Cyclone devices require a certain amount of power-up current to successfully power up because of the nature of the leading-edge process on which they are fabricated.

Table 39 shows the maximum power-up current required to power up a Cyclone device. Designers should select power supplies and regulators that can supply this amount of current when designing with Cyclone devices. This specification is for commercial operating conditions. Measurements were performed with an isolated Cyclone device on the board. Decoupling capacitors were not used in this measurement. To factor in the current for decoupling capacitors, sum up the current for each capacitor using the following equation:

$$I = C (dV/dt)$$

Device	Maximum Power-Up Current Requirement	Unit
EP1C3	300	mA
EP1C4 (1)	400	mA
EP1C6 (2)	500	mA
EP1C12	900	mA
EP1C20	1,200	mA

**Notes to Table 39:**

- (1) The EP1C4 maximum power-up current is an estimated specification and may change.
- (2) The EP1C6 maximum power-up current is for all EP1C6 devices except for those with lot codes listed in the [Cyclone FPGA Family Errata Sheet](#).

The exact amount of current that will be consumed varies according to the process, temperature, and power ramp rate. If the power supply or regulator can supply more current than required, the Cyclone device may consume more current than the maximum current specified in [Table 39](#). However, the device does not require any more current to successfully power up than what is listed in [Table 39](#).

The duration of the I<sub>CCINT</sub> power-up requirement depends on the V<sub>CCINT</sub> voltage supply rise time. The power-up current consumption drops when the V<sub>CCINT</sub> supply reaches approximately 0.75 V. For example, if the V<sub>CCINT</sub> rise time has a linear rise of 15 ms, the current consumption spike will drop by 7.5 ms.

Typically, the user-mode current during device operation is lower than the power-up current in [Table 39](#). Altera recommends using the Cyclone Power Calculator, available on the Altera web site, to estimate the user-mode I<sub>CCINT</sub> consumption and then select power supplies or regulators based on the higher value.

## Timing Model

The DirectDrive technology and MultiTrack interconnect ensure predictable performance, accurate simulation, and accurate timing analysis across all Cyclone device densities and speed grades. This section describes and specifies the performance, internal, external, and PLL timing specifications.

All specifications are representative of worst-case supply voltage and junction temperature conditions.

## Preliminary & Final Timing

Timing models can have either preliminary or final status. The Quartus II software issues an informational message during the design compilation if the timing models are preliminary. Table 40 shows the status of the Cyclone device timing models.

Preliminary status means the timing model is subject to change. Initially, timing numbers are created using simulation results, process data, and other known parameters. These tests are used to make the preliminary numbers as close to the actual timing parameters as possible.

Final timing numbers are based on actual device operation and testing. These numbers reflect the actual performance of the device under worst-case voltage and junction temperature conditions.

Device	Preliminary	Final
EP1C3	✓	
EP1C4	✓	
EP1C6	✓	
EP1C12	✓	
EP1C20	✓	

## Internal Timing Parameters

Internal timing parameters are specified on a speed grade basis independent of device density. Tables 41 through 44 describe the Cyclone device internal timing microparameters for LEs, IOEs, M4K memory structures, and MultiTrack interconnects.

Symbol	Parameter
$t_{SU}$	LE register setup time before clock
$t_H$	LE register hold time after clock
$t_{CO}$	LE register clock-to-output delay
$t_{LUT}$	LE combinatorial LUT delay for data-in to data-out
$t_{CLR}$	Minimum clear pulse width
$t_{PRE}$	Minimum preset pulse width
$t_{CLKHL}$	Minimum clock high or low time

<b>Table 42. IOE Internal Timing Microparameter Descriptions</b>	
<b>Symbol</b>	<b>Parameter</b>
$t_{SU}$	IOE input and output register setup time before clock
$t_H$	IOE input and output register hold time after clock
$t_{CO}$	IOE input and output register clock-to-output delay
$t_{PIN2COMBOUT\_R}$	Row input pin to IOE combinatorial output
$t_{PIN2COMBOUT\_C}$	Column input pin to IOE combinatorial output
$t_{COMBIN2PIN\_R}$	Row IOE data input to combinatorial output pin
$t_{COMBIN2PIN\_C}$	Column IOE data input to combinatorial output pin
$t_{CLR}$	Minimum clear pulse width
$t_{PRE}$	Minimum preset pulse width
$t_{CLKHL}$	Minimum clock high or low time

<b>Table 43. M4K Block Internal Timing Microparameter Descriptions</b>	
<b>Symbol</b>	<b>Parameter</b>
$t_{M4KRC}$	Synchronous read cycle time
$t_{M4KWC}$	Synchronous write cycle time
$t_{M4KWERSU}$	Write or read enable setup time before clock
$t_{M4KWEREH}$	Write or read enable hold time after clock
$t_{M4KBESU}$	Byte enable setup time before clock
$t_{M4KBEH}$	Byte enable hold time after clock
$t_{M4KDATAASU}$	A port data setup time before clock
$t_{M4KDATAAH}$	A port data hold time after clock
$t_{M4KADDRASU}$	A port address setup time before clock
$t_{M4KADDRAH}$	A port address hold time after clock
$t_{M4KDATABSU}$	B port data setup time before clock
$t_{M4KDATABH}$	B port data hold time after clock
$t_{M4KADDRBSU}$	B port address setup time before clock
$t_{M4KADDRBH}$	B port address hold time after clock
$t_{M4KDATAACO1}$	Clock-to-output delay when using output registers
$t_{M4KDATAACO2}$	Clock-to-output delay without output registers
$t_{M4KCLKHL}$	Minimum clock high or low time
$t_{M4KCLR}$	Minimum clear pulse width

Symbol	Parameter
$t_{R4}$	Delay for an R4 line with average loading; covers a distance of four LAB columns
$t_{C4}$	Delay for an C4 line with average loading; covers a distance of four LAB rows
$t_{LOCAL}$	Local interconnect delay

Figure 37 shows the memory waveforms for the M4K timing parameters shown in Table 43.

**Figure 37. Dual-Port RAM Timing Microparameter Waveform**

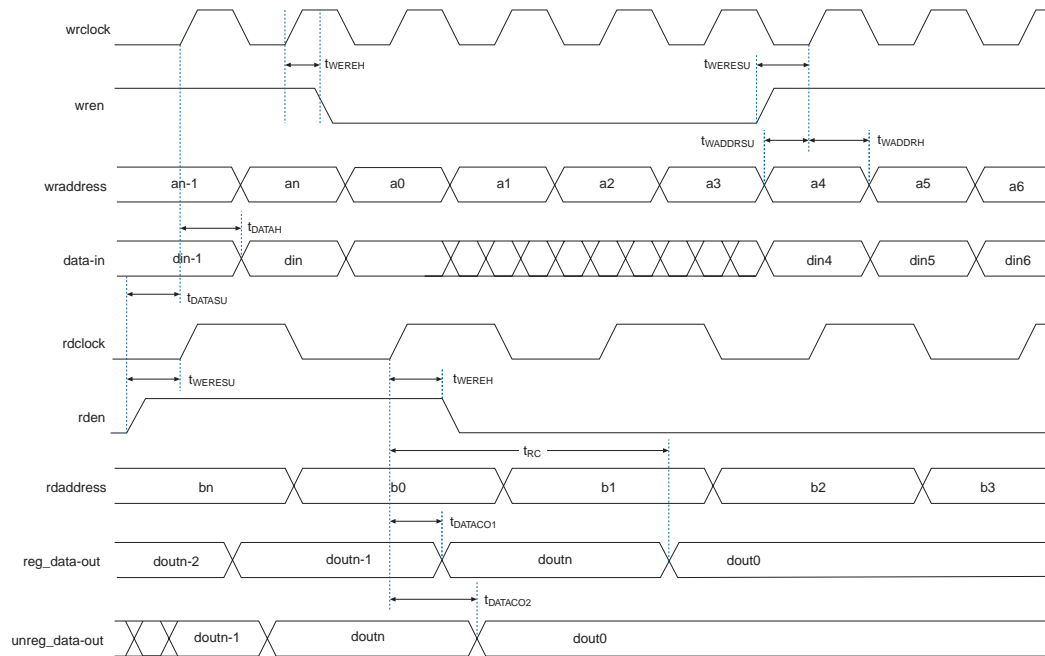

Internal timing parameters are specified on a speed grade basis independent of device density. Tables 45 through 48 show the internal timing microparameters for LEs, IOEs, TriMatrix memory structures, DSP blocks, and MultiTrack interconnects.

Symbol	-6		-7		-8		Unit
	Min	Max	Min	Max	Min	Max	
$t_{SU}$	29		33		37		ps
$t_H$	12		13		15		ps
$t_{CO}$		173		198		224	ps
$t_{LUT}$		454		522		590	ps
$t_{CLR}$	129		148		167		ps
$t_{PRE}$	129		148		167		ps
$t_{CLKHL}$	107		123		139		ps

Symbol	-6		-7		-8		Unit
	Min	Max	Min	Max	Min	Max	
$t_{SU}$	98		107		117		ps
$t_H$	65		71		78		ps
$t_{CO}$		161		177		193	ps
$t_{PIN2COMBOUT\_R}$		1,107		1,217		1,328	ps
$t_{PIN2COMBOUT\_C}$		1,112		1,223		1,334	ps
$t_{COMBIN2PIN\_R}$		2,776		3,053		3,331	ps
$t_{COMBIN2PIN\_C}$		2,764		3,040		3,316	ps
$t_{CLR}$	280		308		336		ps
$t_{PRE}$	280		308		336		ps
$t_{CLKHL}$	95		104		114		ps

Symbol	-6		-7		-8		Unit
	Min	Max	Min	Max	Min	Max	
$t_{M4KRC}$		4,379		5,035		5,691	ps
$t_{M4KWC}$		2,910		3,346		3,783	ps
$t_{M4KWERSU}$	72		82		93		ps
$t_{M4KWEREH}$	43		49		55		ps
$t_{M4KBESU}$	72		82		93		ps
$t_{M4KBEH}$	43		49		55		ps
$t_{M4KDATAASU}$	72		82		93		ps
$t_{M4KDATAAH}$	43		49		55		ps
$t_{M4KADDRASU}$	72		82		93		ps
$t_{M4KADDRAH}$	43		49		55		ps
$t_{M4KDATABSU}$	72		82		93		ps
$t_{M4KDATABH}$	43		49		55		ps
$t_{M4KADDRBSU}$	72		82		93		ps
$t_{M4KADDRBH}$	43		49		55		ps
$t_{M4KDATAO1}$		621		714		807	ps
$t_{M4KDATAO2}$		4,351		5,003		5,656	ps
$t_{M4KCLKHL}$	105		120		136		ps
$t_{M4KCLR}$	286		328		371		ps

Symbol	-6		-7		-8		Unit
	Min	Max	Min	Max	Min	Max	
$t_{R4}$		261		300		339	ps
$t_{C4}$		338		388		439	ps
$t_{LOCAL}$		244		281		318	ps

### External Timing Parameters

External timing parameters are specified by device density and speed grade. [Figure 38](#) shows the timing model for bidirectional IOE pin timing. All registers are within the IOE.

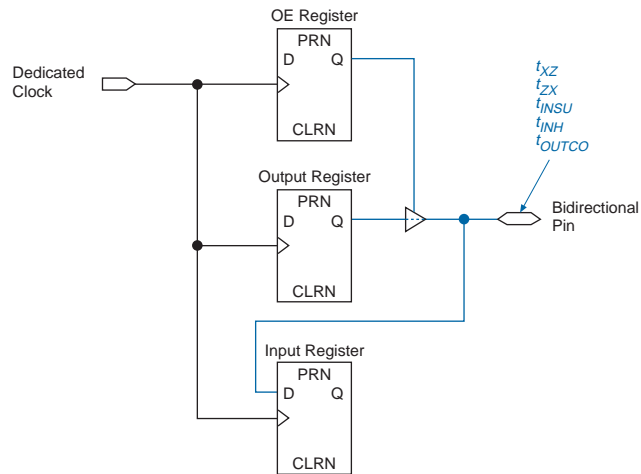
**Figure 38. External Timing in Cyclone Devices**

All external I/O timing parameters shown are for 3.3-V LVTTTL I/O standard with the maximum current strength and fast slew rate. For external I/O timing using standards other than LVTTTL or for different current strengths, use the I/O standard input and output delay adders in [Tables 60 through 64](#).

Table 49 shows the external I/O timing parameters when using global clock networks.

<b>Table 49. Cyclone Global Clock External I/O Timing Parameters</b> <i>Notes (1), (2)</i>		
<b>Symbol</b>	<b>Parameter</b>	<b>Conditions</b>
$t_{INSU}$	Setup time for input or bidirectional pin using IOE input register with global clock fed by CLK pin	
$t_{INH}$	Hold time for input or bidirectional pin using IOE input register with global clock fed by CLK pin	
$t_{OUTCO}$	Clock-to-output delay output or bidirectional pin using IOE output register with global clock fed by CLK pin	$C_{LOAD} = 10 \text{ pF}$
$t_{XZ}$	Synchronous column IOE output enable register to output pin disable delay using global clock fed by CLK pin	$C_{LOAD} = 10 \text{ pF}$
$t_{ZX}$	Synchronous column IOE output enable register to output pin enable delay using global clock fed by CLK pin	$C_{LOAD} = 10 \text{ pF}$
$t_{INSUPLL}$	Setup time for input or bidirectional pin using IOE input register with global clock fed by Enhanced PLL with default phase setting	
$t_{INHPLL}$	Hold time for input or bidirectional pin using IOE input register with global clock fed by enhanced PLL with default phase setting	
$t_{OUTCOPLL}$	Clock-to-output delay output or bidirectional pin using IOE output register with global clock enhanced PLL with default phase setting	$C_{LOAD} = 10 \text{ pF}$
$t_{XZPLL}$	Synchronous column IOE output enable register to output pin disable delay using global clock fed by enhanced PLL with default phase setting	$C_{LOAD} = 10 \text{ pF}$
$t_{ZXPLL}$	Synchronous column IOE output enable register to output pin enable delay using global clock fed by enhanced PLL with default phase setting	$C_{LOAD} = 10 \text{ pF}$

**Notes to Table 49:**

- (1) These timing parameters are sample-tested only.
- (2) These timing parameters are for IOE pins using a 3.3-V LVTTTL, 24-mA setting. Designers should use the Quartus II software to verify the external timing for any pin.

Tables 50 through 51 show the external timing parameters on column and row pins for EP1C3 devices.

**Table 50. EP1C3 Column Pin Global Clock External I/O Timing Parameters**

Symbol	-6 Speed Grade		-7 Speed Grade		-8 Speed Grade		Unit
	Min	Max	Min	Max	Min	Max	
$t_{INSU}$	2.496		2.715		2.935		ns
$t_{INH}$	0.000		0.000		0.000		ns
$t_{OUTCO}$	2.000	3.656	2.000	4.049	2.000	4.445	ns
$t_{XZ}$		5.283		5.840		6.398	ns
$t_{ZX}$		5.283		5.840		6.398	ns
$t_{INSUPLL}$	1.195		1.308		1.421		ns
$t_{INHPLL}$	0.000		0.000		0.000		ns
$t_{OUTCOPLL}$	0.500	1.900	0.500	2.094	0.500	2.291	ns
$t_{XZPLL}$	3.527		3.885		4.244		ns
$t_{ZXPLL}$	3.527		3.885		4.244		ns

**Table 51. EP1C3 Row Pin Global Clock External I/O Timing Parameters**

Symbol	-6 Speed Grade		-7 Speed Grade		-8 Speed Grade		Unit
	Min	Max	Min	Max	Min	Max	
$t_{INSU}$	2.574		2.806		3.041		ns
$t_{INH}$	0.000		0.000		0.000		ns
$t_{OUTCO}$	2.000	3.561	2.000	3.939	2.000	4.319	ns
$t_{XZ}$		5.147		5.684		6.223	ns
$t_{ZX}$		5.147		5.684		6.223	ns
$t_{INSUPLL}$	1.273		1.399		1.527		ns
$t_{INHPLL}$	0.000		0.000		0.000		ns
$t_{OUTCOPLL}$	0.500	1.805	0.500	1.984	0.500	2.165	ns
$t_{XZPLL}$	3.391		3.729		4.069		ns
$t_{ZXPLL}$	3.391		3.729		4.069		ns

Tables 52 through 53 show the external timing parameters on column and row pins for EP1C4 devices.

**Table 52. EP1C4 Column Pin Global Clock External I/O Timing Parameters (1)**

Symbol	-6 Speed Grade		-7 Speed Grade		-8 Speed Grade		Unit
	Min	Max	Min	Max	Min	Max	
$t_{INSU}$							ns
$t_{INH}$							ns
$t_{OUTCO}$							ns
$t_{XZ}$							ns
$t_{ZX}$							ns
$t_{INSUPLL}$							ns
$t_{INHPLL}$							ns
$t_{OUTCOPLL}$							ns
$t_{XZPLL}$							ns
$t_{ZXPLL}$							ns

**Table 53. EP1C4 Row Pin Global Clock External I/O Timing Parameters (1)**

Symbol	-6 Speed Grade		-7 Speed Grade		-8 Speed Grade		Unit
	Min	Max	Min	Max	Min	Max	
$t_{INSU}$							ns
$t_{INH}$							ns
$t_{OUTCO}$							ns
$t_{XZ}$							ns
$t_{ZX}$							ns
$t_{INSUPLL}$							ns
$t_{INHPLL}$							ns
$t_{OUTCOPLL}$							ns
$t_{XZPLL}$							ns
$t_{ZXPLL}$							ns

Note to Tables 52 and 53:

(1) Contact Altera Applications for EP1C4 device timing parameters.

Tables 54 through 55 show the external timing parameters on column and row pins for EP1C6 devices.

**Table 54. EP1C6 Column Pin Global Clock External I/O Timing Parameters**

Symbol	-6 Speed Grade		-7 Speed Grade		-8 Speed Grade		Unit
	Min	Max	Min	Max	Min	Max	
$t_{INSU}$	2.432		2.643		2.853		ns
$t_{INH}$	0.000		0.000		0.000		ns
$t_{OUTCO}$	2.000	3.720	2.000	4.121	2.000	4.527	ns
$t_{XZ}$		5.347		5.912		6.480	ns
$t_{ZX}$		5.347		5.912		6.480	ns
$t_{INSUPLL}$	1.188		1.301		1.414		ns
$t_{INHPLL}$	0.000		0.000		0.000		ns
$t_{OUTCOPLL}$	0.500	1.907	0.500	2.101	0.500	2.298	ns
$t_{XZPLL}$	3.534		3.892		4.251		ns
$t_{ZXPLL}$	3.534		3.892		4.251		ns

**Table 55. EP1C6 Row Pin Global Clock External I/O Timing Parameters**

Symbol	-6 Speed Grade		-7 Speed Grade		-8 Speed Grade		Unit
	Min	Max	Min	Max	Min	Max	
$t_{INSU}$	2.517		2.741		2.966		ns
$t_{INH}$	0.000		0.000		0.000		ns
$t_{OUTCO}$	2.000	3.618	2.000	4.004	2.000	4.394	ns
$t_{XZ}$		5.204		5.749		6.298	ns
$t_{ZX}$		5.204		5.749		6.298	ns
$t_{INSUPLL}$	1.273		1.399		1.527		ns
$t_{INHPLL}$	0.000		0.000		0.000		ns
$t_{OUTCOPLL}$	0.500	1.805	0.500	1.984	0.500	2.165	ns
$t_{XZPLL}$	3.391		3.729		4.069		ns
$t_{ZXPLL}$	3.391		3.729		4.069		ns

Tables 56 through 57 show the external timing parameters on column and row pins for EP1C12 devices.

**Table 56. EP1C12 Column Pin Global Clock External I/O Timing Parameters**

Symbol	-6 Speed Grade		-7 Speed Grade		-8 Speed Grade		Unit
	Min	Max	Min	Max	Min	Max	
$t_{INSU}$	2.187		2.363		2.535		ns
$t_{INH}$	0.000		0.000		0.000		ns
$t_{OUTCO}$	2.000	3.965	2.000	4.401	2.000	4.845	ns
$t_{XZ}$		5.592		6.192		6.798	ns
$t_{ZX}$		5.592		6.192		6.798	ns
$t_{INSUPLL}$	1.152		1.260		1.368		ns
$t_{INHPLL}$	0.000		0.000		0.000		ns
$t_{OUTCOPLL}$	0.500	1.943	0.500	2.142	0.500	2.344	ns
$t_{XZPLL}$	3.570		3.933		4.297		ns
$t_{ZXPLL}$	3.570		3.933		4.297		ns

**Table 57. EP1C12 Row Pin Global Clock External I/O Timing Parameters**

Symbol	-6 Speed Grade		-7 Speed Grade		-8 Speed Grade		Unit
	Min	Max	Min	Max	Min	Max	
$t_{INSU}$	2.308		2.502		2.694		ns
$t_{INH}$	0.000		0.000		0.000		ns
$t_{OUTCO}$	2.000	3.827	2.000	4.243	2.000	4.666	ns
$t_{XZ}$		5.413		5.988		6.570	ns
$t_{ZX}$		5.413		5.988		6.570	ns
$t_{INSUPLL}$	1.273		1.399		1.527		ns
$t_{INHPLL}$	0.000		0.000		0.000		ns
$t_{OUTCOPLL}$	0.500	1.805	0.500	1.984	0.500	2.165	ns
$t_{XZPLL}$	3.391		3.729		4.069		ns
$t_{ZXPLL}$	3.391		3.729		4.069		ns

Tables 58 through 59 show the external timing parameters on column and row pins for EP1C20 devices.

**Table 58. EP1C20 Column Pin Global Clock External I/O Timing Parameters**

Symbol	-6 Speed Grade		-7 Speed Grade		-8 Speed Grade		Unit
	Min	Max	Min	Max	Min	Max	
$t_{INSU}$	2.226		2.406		2.585		ns
$t_{INH}$	0.000		0.000		0.000		ns
$t_{OUTCO}$	2.000	3.926	2.000	4.358	2.000	4.795	ns
$t_{XZ}$		5.553		6.149		6.748	ns
$t_{ZX}$		5.553		6.149		6.748	ns
$t_{INSUPLL}$	1.138		1.244		1.349		ns
$t_{INHPLL}$	0.000		0.000		0.000		ns
$t_{OUTCOPLL}$	0.500	1.957	0.500	2.158	0.500	2.363	ns
$t_{XZPLL}$	3.584		3.949		4.316		ns
$t_{ZXPLL}$	3.584		3.949		4.316		ns

**Table 59. EP1C20 Row Pin Global Clock External I/O Timing Parameters**

Symbol	-6 Speed Grade		-7 Speed Grade		-8 Speed Grade		Unit
	Min	Max	Min	Max	Min	Max	
$t_{INSU}$	2.361		2.561		2.763		ns
$t_{INH}$	0.000		0.000		0.000		ns
$t_{OUTCO}$	2.000	3.774	2.000	4.184	2.000	4.597	ns
$t_{XZ}$		5.360		5.929		6.501	ns
$t_{ZX}$		5.360		5.929		6.501	ns
$t_{INSUPLL}$	1.273		1.399		1.527		ns
$t_{INHPLL}$	0.000		0.000		0.000		ns
$t_{OUTCOPLL}$	0.500	1.805	0.500	1.984	0.500	2.165	ns
$t_{XZPLL}$	3.391		3.729		4.069		ns
$t_{ZXPLL}$	3.391		3.729		4.069		ns

### External I/O Delay Parameters

External I/O delay timing parameters for I/O standard input and output adders and programmable input and output delays are specified by speed grade independent of device density.

Tables 60 through 65 show the adder delays associated with column and row I/O pins for all packages. If an I/O standard is selected other than LVTTTL 24 mA with a fast slew rate, add the selected delay to the external  $t_{CO}$  and  $t_{SU}$  I/O parameters shown in Tables 45 through 48.

I/O Standard	-6 Speed Grade		-7 Speed Grade		-8 Speed Grade		Unit
	Min	Max	Min	Max	Min	Max	
LVC MOS		0		0		0	ps
3.3-V LVTTTL		0		0		0	ps
2.5-V LVTTTL		28		30		33	ps
1.8-V LVTTTL		214		235		256	ps
1.5-V LVTTTL		326		358		391	ps
SSTL-3 class I		-221		-244		-266	ps
SSTL-3 class II		-221		-244		-266	ps
SSTL-2 class I		-264		-291		-317	ps
SSTL-2 class II		-264		-291		-317	ps
LVDS		-197		-217		-237	ps

I/O Standard	-6 Speed Grade		-7 Speed Grade		-8 Speed Grade		Unit
	Min	Max	Min	Max	Min	Max	
LVC MOS		0		0		0	ps
3.3-V LVTTTL		0		0		0	ps
2.5-V LVTTTL		28		30		33	ps
1.8-V LVTTTL		214		235		256	ps
1.5-V LVTTTL		326		358		391	ps
3.3-V PCI (1)		0		0		0	ps
SSTL-3 class I		-221		-244		-266	ps
SSTL-3 class II		-221		-244		-266	ps
SSTL-2 class I		-264		-291		-317	ps
SSTL-2 class II		-264		-291		-317	ps
LVDS		-197		-217		-237	ps

Standard		-6 Speed Grade		-7 Speed Grade		-8 Speed Grade		Unit
		Min	Max	Min	Max	Min	Max	
LVCMOS	2 mA		1,105		1,216		1,326	ps
	4 mA		601		661		721	ps
	8 mA		137		151		164	ps
	12 mA		0		0		0	ps
3.3-V LVTTTL	4 mA		1,105		1,216		1,326	ps
	8 mA		740		814		888	ps
	12 mA		130		143		156	ps
	16 mA		178		196		213	ps
	24 mA		0		0		0	ps
2.5-V LVTTTL	2 mA		1,504		1,654		1,804	ps
	8 mA		307		338		368	ps
	12 mA		338		372		405	ps
	16 mA		195		214		234	ps
1.8-V LVTTTL	2 mA		1,062		1,168		1,274	ps
	8 mA		812		893		974	ps
	12 mA		812		893		974	ps
1.5-V LVTTTL	2 mA		2,556		2,812		3,067	ps
	4 mA		1,613		1,774		1,935	ps
	8 mA		1,064		1,170		1,276	ps
SSTL-3 class I			616		678		739	ps
SSTL-3 class II			180		198		216	ps
SSTL-2 class I			528		581		633	ps
SSTL-2 class II			233		256		279	ps
LVDS			147		162		176	ps

Standard		-6 Speed Grade		-7 Speed Grade		-8 Speed Grade		Unit
		Min	Max	Min	Max	Min	Max	
LVCMOS	2 mA		1,105		1,216		1,326	ps
	4 mA		601		661		721	ps
	8 mA		137		151		164	ps
	12 mA		0		0		0	ps

Standard		-6 Speed Grade		-7 Speed Grade		-8 Speed Grade		Unit
		Min	Max	Min	Max	Min	Max	
3.3-V LVTTTL	4 mA		1,105		1,216		1,326	ps
	8 mA		740		814		888	ps
	12 mA		130		143		156	ps
	16 mA		178		196		213	ps
	24 mA		0		0		0	ps
2.5-V LVTTTL	2 mA		1,504		1,654		1,804	ps
	8 mA		307		338		368	ps
	12 mA		338		372		405	ps
	16 mA		195		214		234	ps
1.8-V LVTTTL	2 mA		2,556		2,812		3,067	ps
	8 mA		1,062		1,168		1,274	ps
	12 mA		812		893		974	ps
1.5-V LVTTTL	2 mA		2,556		2,812		3,067	ps
	4 mA		1,613		1,774		1,935	ps
	8 mA		1,064		1,170		1,276	ps
3.3-V PCI (1)			-8		-9		-10	ps
SSTL-3 class I			616		678		739	ps
SSTL-3 class II			180		198		216	ps
SSTL-2 class I			528		581		633	ps
SSTL-2 class II			233		256		279	ps
LVDS			147		162		176	ps

I/O Standard		-6 Speed Grade		-7 Speed Grade		-8 Speed Grade		Unit
		Min	Max	Min	Max	Min	Max	
LVCMOS	2 mA		2,288		2,517		2,745	ps
	4 mA		1,784		1,962		2,140	ps
	8 mA		1,320		1,452		1,583	ps
	12 mA		1,183		1,301		1,419	ps
3.3-V LVTTTL	4 mA		2,760		3,036		3,312	ps
	8 mA		2,395		2,634		2,874	ps
	12 mA		1,785		1,963		2,142	ps
	16 mA		1,833		2,016		2,199	ps
	24 mA		1,655		1,820		1,986	ps

**Table 64. Cyclone I/O Standard Output Delay Adders for Slow Slew Rate on Column Pins (Part 2 of 2)**

I/O Standard		-6 Speed Grade		-7 Speed Grade		-8 Speed Grade		Unit
		Min	Max	Min	Max	Min	Max	
2.5-V LVTTTL	2 mA		3,643		4,006		4,370	ps
	8 mA		2,446		2,690		2,934	ps
	12 mA		2,477		2,724		2,971	ps
	16 mA		2,334		2,566		2,800	ps
1.8-V LVTTTL	2 mA		6,606		7,267		7,927	ps
	8 mA		5,112		5,623		6,134	ps
	12 mA		4,862		5,348		5,834	ps
1.5-V LVTTTL	2 mA		8,380		9,218		10,055	ps
	4 mA		7,437		8,180		8,923	ps
	8 mA		6,888		7,576		8,264	ps
SSTL-3 class I			1,799		1,979		2,158	ps
SSTL-3 class II			1,363		1,499		1,635	ps
SSTL-2 class I			2,115		2,326		2,537	ps
SSTL-2 class II			1,820		2,001		2,183	ps
LVDS			1,330		1,463		1,595	ps

**Table 65. Cyclone I/O Standard Output Delay Adders for Slow Slew Rate on Row Pins (Part 1 of 2)**

I/O Standard		-6 Speed Grade		-7 Speed Grade		-8 Speed Grade		Unit
		Min	Max	Min	Max	Min	Max	
LVCMOS	2 mA		2,288		2,517		2,745	ps
	4 mA		1,784		1,962		2,140	ps
	8 mA		1,320		1,452		1,583	ps
	12 mA		1,183		1,301		1,419	ps
3.3-V LVTTTL	4 mA		2,760		3,036		3,312	ps
	8 mA		2,395		2,634		2,874	ps
	12 mA		1,785		1,963		2,142	ps
	16 mA		1,833		2,016		2,199	ps
	24 mA		1,655		1,820		1,986	ps
2.5-V LVTTTL	2 mA		3,643		4,006		4,370	ps
	8 mA		2,446		2,690		2,934	ps
	12 mA		2,477		2,724		2,971	ps
	16 mA		2,334		2,566		2,800	ps

I/O Standard		-6 Speed Grade		-7 Speed Grade		-8 Speed Grade		Unit
		Min	Max	Min	Max	Min	Max	
1.8-V LVTTTL	2 mA		6,606		7,267		7,927	ps
	8 mA		5,112		5,623		6,134	ps
	12 mA		4,862		5,348		5,834	ps
1.5-V LVTTTL	2 mA		8,380		9,218		10,055	ps
	4 mA		7,437		8,180		8,923	ps
	8 mA		6,888		7,576		8,264	ps
3.3-V PCI			1,175		1,292		1,409	ps
SSTL-3 class I			1,799		1,979		2,158	ps
SSTL-3 class II			1,363		1,499		1,635	ps
SSTL-2 class I			2,115		2,326		2,537	ps
SSTL-2 class II			1,820		2,001		2,183	ps
LVDS			1,330		1,463		1,595	ps

Note to [Tables 60 – 65](#):

(1) EP1C3 devices do not support the PCII/O standard.

[Table 66](#) shows the adder delays for the IOE programmable delays. These delays are controlled with the Quartus II software options listed in the Parameter column.

Parameter	Setting	-6 Speed Grade		-7 Speed Grade		-8 Speed Grade		Unit
		Min	Max	Min	Max	Min	Max	
Decrease input delay to internal cells	On		3,057		3,362		3,668	ps
	Small		2,212		2,433		2,654	ps
	Medium		2,639		2,902		3,166	ps
	Large		3,057		3,362		3,668	ps
Decrease input delay to input register	On		3,057		3,362		3,668	ps
Increase delay to output pin	On		552		607		662	ps

Parameter	Setting	-6 Speed Grade		-7 Speed Grade		-8 Speed Grade		Unit
		Min	Max	Min	Max	Min	Max	
Decrease input delay to internal cells	On		3,057		3,362		3,668	ps
	Small		2,212		2,433		2,654	ps
	Medium		2,639		2,902		3,166	ps
	Large		3,057		3,362		3,668	ps
Decrease input delay to input register	On		3,057		3,362		3,668	ps
Increase delay to output pin	On		556		611		667	ps

### Maximum Input & Output Clock Rates

Tables 68 and 69 show the maximum input clock rate for column and row pins in Cyclone devices.

I/O Standard	-6 Speed Grade	-7 Speed Grade	-8 Speed Grade	Unit
LVTTTL	304	304	304	MHz
2.5 V	220	220	220	MHz
1.8 V	213	213	213	MHz
1.5 V	166	166	166	MHz
LVC MOS	304	304	304	MHz
SSTL-3 class I	100	100	100	MHz
SSTL-3 class II	100	100	100	MHz
SSTL-2 class I	134	134	134	MHz
SSTL-2 class II	134	134	134	MHz
LVDS	231	231	231	MHz

**Table 69. Cyclone Maximum Input Clock Rate for Row Pins**

I/O Standard	-6 Speed Grade	-7 Speed Grade	-8 Speed Grade	Unit
LVTTTL	304	304	304	MHz
2.5 V	220	220	220	MHz
1.8 V	213	213	213	MHz
1.5 V	166	166	166	MHz
LVC MOS	304	304	304	MHz
SSTL-3 class I	100	100	100	MHz
SSTL-3 class II	100	100	100	MHz
SSTL-2 class I	134	134	134	MHz
SSTL-2 class II	134	134	134	MHz
3.3-V PCI (1)	66	66	66	MHz
LVDS	231	231	231	MHz

Note to Tables 68 – 69:

- (1) EP1C3 devices do not support the PCI I/O standard. These parameters are only available on row I/O pins.

Tables 70 and 71 show the maximum output clock rate for column and row pins in Cyclone devices.

**Table 70. Cyclone Maximum Output Clock Rate for Column Pins**

I/O Standard	-6 Speed Grade	-7 Speed Grade	-8 Speed Grade	Unit
LVTTTL	304	304	304	MHz
2.5 V	220	220	220	MHz
1.8 V	213	213	213	MHz
1.5 V	166	166	166	MHz
LVC MOS	304	304	304	MHz
SSTL-3 class I	100	100	100	MHz
SSTL-3 class II	100	100	100	MHz
SSTL-2 class I	134	134	134	MHz
SSTL-2 class II	134	134	134	MHz
LVDS	231	231	231	MHz

**Table 71. Cyclone Maximum Output Clock Rate for Row Pins**

I/O Standard	-6 Speed Grade	-7 Speed Grade	-8 Speed Grade	Unit
LVTTTL	304	304	304	MHz
2.5 V	220	220	220	MHz
1.8 V	213	213	213	MHz
1.5 V	166	166	166	MHz
LVC MOS	304	304	304	MHz
SSTL-3 class I	100	100	100	MHz
SSTL-3 class II	100	100	100	MHz
SSTL-2 class I	134	134	134	MHz
SSTL-2 class II	134	134	134	MHz
3.3-V PCI (1)	66	66	66	MHz
LVDS	231	231	231	MHz

Note to **Tables 70 – 71:**

- (1) EP1C3 devices do not support the PCI I/O standard. These parameters are only available on row I/O pins.

## Software

Cyclone devices are supported by the Altera Quartus II design software, which provides a comprehensive environment for system-on-a-programmable-chip (SOPC) design. The Quartus II software includes HDL and schematic design entry, compilation and logic synthesis, full simulation and advanced timing analysis, SignalTap II logic analysis, and device configuration. See the Design Software Selector Guide for more details on the Quartus II software features.

The Quartus II software supports the Windows 2000/NT/98, Sun Solaris, Linux Red Hat v7.1 and HP-UX operating systems. It also supports seamless integration with industry-leading EDA tools through the NativeLink® interface.

## Device Pin-Outs

Device pin-outs for Cyclone devices are available on the Altera web site (<http://www.altera.com>).

## Ordering Information

Figure 39 describes the ordering codes for Cyclone devices. For more information on a specific package, refer to the *Altera Device Package Information Data Sheet*.

**Figure 39. Cyclone Device Packaging Ordering Information**



## Revision History

The information contained in the *Cyclone FPGA Family Data Sheet* version 1.2 supersedes information published in previous versions.

### Version 1.2

The following changes were made to the *Cyclone FPGA Family Data Sheet* version 1.2: updated the “**Power Consumption**” section.

### Version 1.1

The following changes were made to the *Cyclone FPGA Family Data Sheet* version 1.1:

- Added the EP1C4 device.
- Updated the “**Timing Model**” section.
- Minor textual updates throughout the document.



101 Innovation Drive  
San Jose, CA 95134  
(408) 544-7000  
<http://www.altera.com>  
**Applications Hotline:**  
(800) 800-EPLD  
**Customer Marketing:**  
(408) 544-7104  
**Literature Services:**  
[lit\\_req@altera.com](mailto:lit_req@altera.com)

Copyright © 2003 Altera Corporation. All rights reserved. Altera, The Programmable Solutions Company, the stylized Altera logo, specific device designations, and all other words and logos that are identified as trademarks and/or service marks are, unless noted otherwise, the trademarks and service marks of Altera Corporation in the U.S. and other countries. All other product or service names are the property of their respective holders. Altera products are protected under numerous U.S. and foreign patents and pending applications, maskwork rights, and copyrights. Altera warrants performance of its semiconductor products to current specifications in accordance with Altera's standard warranty, but reserves the right to make changes to any products and services at any time without notice. Altera assumes no responsibility or liability arising out of the application or use of any information, product, or service described herein except as expressly agreed to in writing by Altera Corporation. Altera customers are advised to obtain the latest version of device specifications before relying on any published information and before placing orders for products or services.





## Looking for pricing, stock, or lifecycle information?

Click below to explore more details on WIN SOURCE:

 [View EP4CE55F23C8 on WIN SOURCE](#)

 [Intel Information](#)

## Optimize Your Supply Chain with WIN SOURCE Solutions

-  Global Sourcing Solution
-  Obsolete Management
-  Cost Control Management
-  Shortage Management
-  Alternative Solution
-  Excess Inventory Management