



**THE DATASHEET OF
AGL030V5-VQG100**



4ppm/°C, 100µA, SOT23-6 SERIES VOLTAGE REFERENCE

Check for Samples: [REF3212](#), [REF3220](#), [REF3225](#), [REF3230](#), [REF3233](#), [REF3240](#)

FEATURES

- **Excellent Specified Drift Performance:**
 - 7ppm/°C (max) at 0°C to +125°C
 - 20ppm/°C (max) at –40°C to +125°C
- **Microsize Package: SOT23-6**
- **High Output Current: ±10mA**
- **High Accuracy: 0.01%**
- **Low Quiescent Current: 100µA**
- **Low Dropout: 5mV**

APPLICATIONS

- **Portable Equipment**
- **Data Acquisition Systems**
- **Medical Equipment**
- **Test Equipment**

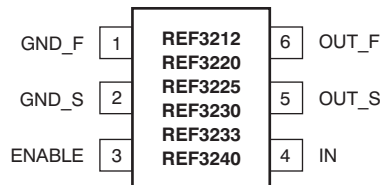

DESCRIPTION

The REF32xx is a very low drift, micropower, low-dropout, precision voltage reference family available in the tiny SOT23-6 package.

The small size and low power consumption (120µA max) of the REF32xx make it ideal for portable and battery-powered applications. This reference is stable with any capacitive load.

The REF32xx can be operated from a supply as low as 5mV above the output voltage, under no load conditions. All models are specified for the wide temperature range of –40°C to +125°C.

AVAILABLE OUTPUT VOLTAGES

PRODUCT	VOLTAGE
REF3212	1.25V
REF3220	2.048V
REF3225	2.5V
REF3230	3.0V
REF3233	3.3V
REF3240	4.096



Please be aware that an important notice concerning availability, standard warranty, and use in critical applications of Texas Instruments semiconductor products and disclaimers thereto appears at the end of this data sheet.

All trademarks are the property of their respective owners.



This integrated circuit can be damaged by ESD. Texas Instruments recommends that all integrated circuits be handled with appropriate precautions. Failure to observe proper handling and installation procedures can cause damage.

ESD damage can range from subtle performance degradation to complete device failure. Precision integrated circuits may be more susceptible to damage because very small parametric changes could cause the device not to meet its published specifications.

PACKAGE INFORMATION⁽¹⁾

PRODUCT	OUTPUT VOLTAGE	PACKAGE-LEAD	PACKAGE DESIGNATOR	PACKAGE MARKING
REF3212	1.25V	SOT23-6	DBV	R32A
REF3220	2.048V	SOT23-6	DBV	R32B
REF3225	2.5V	SOT23-6	DBV	R32C
REF3230	3.0V	SOT23-6	DBV	R32D
REF3233	3.3V	SOT23-6	DBV	R32E
REF3240	4.096	SOT23-6	DBV	R32F

(1) For the most current package and ordering information see the Package Option Addendum at the end of this document, or visit the device product folder at www.ti.com.

ABSOLUTE MAXIMUM RATINGS⁽¹⁾

Over operating free-air temperature range (unless otherwise noted).

		REF32xx	UNIT
Input voltage		+7.5	V
Output short-circuit		Continuous	
Operating temperature		-55 to +135	°C
Storage temperature		-65 to +150	°C
Junction temperature		+150	°C
ESD ratings	Human body model (HBM)	4	kV
	Charged device model (CDM)	1	kV
	Machine model (MM)	400	V

(1) Stresses above these ratings may cause permanent damage. Exposure to absolute maximum conditions for extended periods may degrade device reliability. These are stress ratings only, and functional operation of the device at these or any other conditions beyond those specified is not implied.

PIN CONFIGURATION

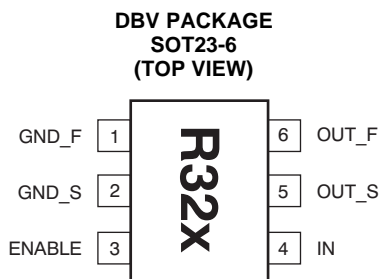

NOTE:: The location of pin 1 on the REF32xx is determined by orienting the package marking as shown in the diagram above.

PIN DESCRIPTIONS

PIN		FUNCTION	DESCRIPTION
NAME	NO.		
ENABLE	3	Digital input	This pin enables and disables the device
GND_F	1	Analog output	Ground connection of the device
GND_S	2	Analog input	Ground sense at the load
IN	4	Analog input	Positive supply voltage
OUT_F	6	Analog output	Output of Reference Voltage
OUT_S	5	Analog input	Sense connection at the load

ELECTRICAL CHARACTERISTICS

Boldface limits apply over the listed temperature range.

At $T_A = +25^\circ\text{C}$, $I_{\text{LOAD}} = 0\text{mA}$, and $V_{\text{IN}} = 5\text{V}$, unless otherwise noted.

PARAMETER	CONDITIONS	REF32xx			UNIT
		MIN	TYP	MAX	
REF3212 (1.25V)					
OUTPUT VOLTAGE, V_{OUT}		1.2475	1.25	1.2525	V
Initial accuracy		-0.2	0.01	0.2	%
NOISE					
Output voltage noise	f = 0.1Hz to 10Hz		17		μV_{PP}
Voltage noise	f = 10Hz to 10kHz		24		μV_{RMS}
REF3220 (2.048V)					
OUTPUT VOLTAGE, V_{OUT}		2.044	2.048	2.052	V
Initial accuracy		-0.2	0.01	0.2	%
NOISE					
Output voltage noise	f = 0.1Hz to 10Hz		27		μV_{PP}
Voltage noise	f = 10Hz to 10kHz		39		μV_{RMS}
REF3225 (2.5V)					
OUTPUT VOLTAGE, V_{OUT}		2.495	2.50	2.505	V
Initial accuracy		-0.2	0.01	0.2	%
NOISE					
Output voltage noise	f = 0.1Hz to 10Hz		33		μV_{PP}
Voltage noise	f = 10Hz to 10kHz		48		μV_{RMS}
REF3230 (3V)					
OUTPUT VOLTAGE, V_{OUT}		2.994	3	3.006	V
Initial accuracy		-0.2	0.01	0.2	%
NOISE					
Output voltage noise	f = 0.1Hz to 10Hz		39		μV_{PP}
Voltage noise	f = 10Hz to 10kHz		57		μV_{RMS}
REF3233 (3.3V)					
OUTPUT VOLTAGE, V_{OUT}		3.293	3.3	3.307	V
Initial accuracy		-0.2	0.01	0.2	%
NOISE					
Output voltage noise	f = 0.1Hz to 10Hz		43		μV_{PP}
Voltage noise	f = 10Hz to 10kHz		63		μV_{RMS}
REF3240 (4.096V)					
OUTPUT VOLTAGE, V_{OUT}		4.088	4.096	4.104	V
Initial accuracy		-0.2	0.01	0.2	%
NOISE					
Output voltage noise	f = 0.1Hz to 10Hz		53		μV_{PP}
Voltage noise	f = 10Hz to 10kHz		78		μV_{RMS}

ELECTRICAL CHARACTERISTICS (continued)

Boldface limits apply over the listed temperature range.

At $T_A = +25^\circ\text{C}$, $I_{\text{LOAD}} = 0\text{mA}$, and $V_{\text{IN}} = 5\text{V}$, unless otherwise noted.

PARAMETER	CONDITIONS	REF32xx			UNIT
		MIN	TYP	MAX	
REF3212 / REF3220 / REF3225 / REF3230 / REF3233 / REF3240					
OUTPUT VOLTAGE TEMP DRIFT	dV_{OUT}/dT				
	$0^\circ\text{C} \leq T_A \leq +125^\circ\text{C}$		4	7	ppm/°C
	$-40^\circ\text{C} \leq T_A \leq +125^\circ\text{C}$		10.5	20	ppm/°C
LONG-TERM STABILITY	0 to 1000h		55		ppm
LINE REGULATION	$V_{\text{OUT}} + 0.05^{(1)} \leq V_{\text{IN}} \leq 5.5\text{V}$	-65	15	+65	ppm/V
LOAD REGULATION ⁽²⁾	$dV_{\text{OUT}}/dI_{\text{LOAD}}$				
Sourcing	$0\text{mA} < I_{\text{LOAD}} < 10\text{mA}$, $V_{\text{IN}} = V_{\text{OUT}} + 250\text{mV}^{(1)}$	-40	3	40	$\mu\text{V}/\text{mA}$
Sinking	$-10\text{mA} < I_{\text{LOAD}} < 0\text{mA}$, $V_{\text{IN}} = V_{\text{OUT}} + 100\text{mV}^{(1)}$	-60	20	60	$\mu\text{V}/\text{mA}$
THERMAL HYSTERESIS ⁽³⁾	dT				
First cycle			100		ppm
Additional cycles			25		ppm
DROPOUT VOLTAGE ⁽¹⁾	$V_{\text{IN}} - V_{\text{OUT}}$		5	50	mV
OUTPUT CURRENT	I_{LOAD}	$V_{\text{IN}} = V_{\text{OUT}} + 250\text{mV}^{(1)}$	-10	10	mA
SHORT-CIRCUIT CURRENT	I_{SC}				
Sourcing			50		mA
Sinking			40		mA
TURN-ON SETTLING TIME	To 0.1% at $V_{\text{IN}} = 5\text{V}$ with $C_L = 0$		60		μs
ENABLE/SHUTDOWN ⁽⁴⁾					
	V_L	Reference in Shutdown mode	0	0.7	V
	V_H	Reference is active	1.5	V_{IN}	V
POWER SUPPLY		$I_L = 0$			
Voltage	V_{IN}		$V_{\text{OUT}} + 0.05^{(1)}$	5.5	V
Current	I_Q	ENABLE > 1.5V		100	μA
Over temperature		$0^\circ\text{C} \leq T_A \leq +125^\circ\text{C}$		115	μA
Shutdown	I_S	ENABLE < 0.7V		0.1	μA
TEMPERATURE RANGE					
Specified			-40	+125	°C
Operating			-55	+135	°C
Storage			-65	+150	°C
Thermal resistance, SOT23-6	θ_{JA}		200		°C/W

(1) The minimum supply voltage for the REF3212 is 1.8V.

(2) Load regulation is using force and sense lines; see the [Load Regulation](#) section for more information.

(3) Thermal hysteresis procedure is explained in more detail in the Applications Information TBD section.

(4) If the rise time of the input voltage is less than or equal to 2ms, the ENABLE and IN pins can be tied together. For rise times greater than 2ms, see the [Supply Voltage](#) section.

TYPICAL CHARACTERISTICS

At $T_A = +25^\circ\text{C}$, $I_{\text{LOAD}} = 0\text{mA}$, $V_{\text{IN}} = +5\text{V}$ power supply, and REF3225 used for typical characteristics, unless otherwise noted.

**TEMPERATURE DRIFT
(0°C to $+125^\circ\text{C}$)**

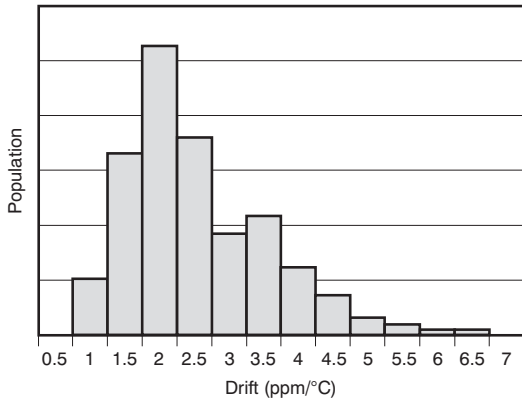

Figure 1.

**TEMPERATURE DRIFT
(-40°C to $+125^\circ\text{C}$)**

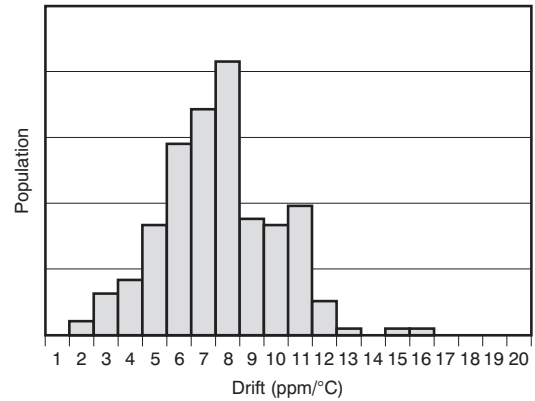

Figure 2.

OUTPUT VOLTAGE ACCURACY vs TEMPERATURE

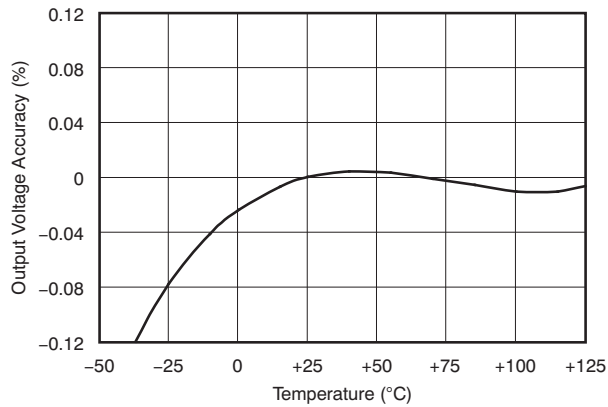

Figure 3.

DROPOUT VOLTAGE vs LOAD CURRENT

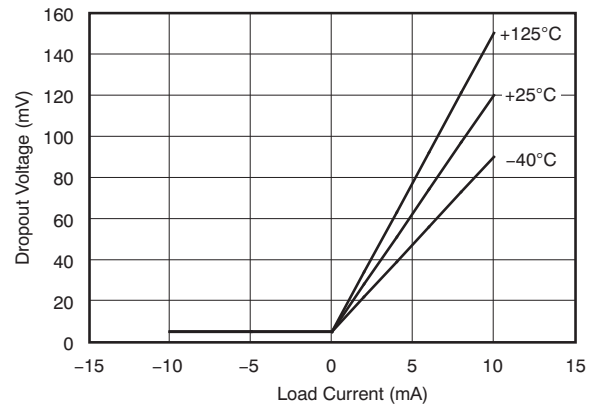

Figure 4.

QUIESCENT CURRENT vs TEMPERATURE

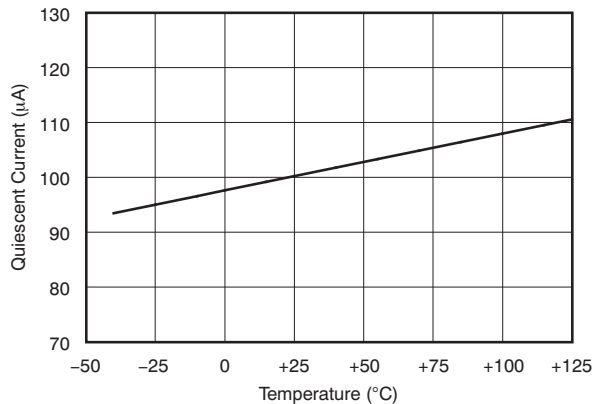

Figure 5.

POWER-SUPPLY REJECTION RATIO vs FREQUENCY

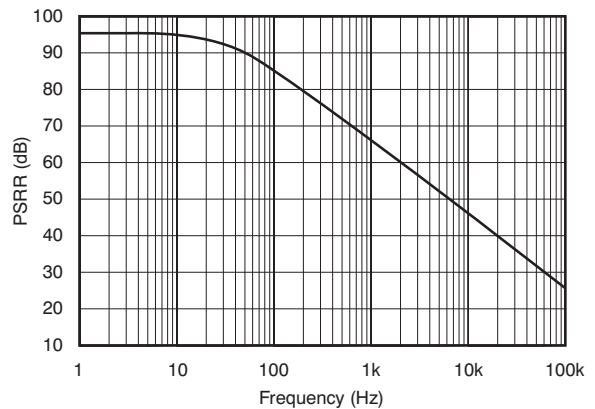

Figure 6.

TYPICAL CHARACTERISTICS (continued)

At $T_A = +25^\circ\text{C}$, $I_{\text{LOAD}} = 0\text{mA}$, $V_{\text{IN}} = +5\text{V}$ power supply, and REF3225 used for typical characteristics, unless otherwise noted.

**OUTPUT VOLTAGE vs INPUT VOLTAGE
 (REF3212)**

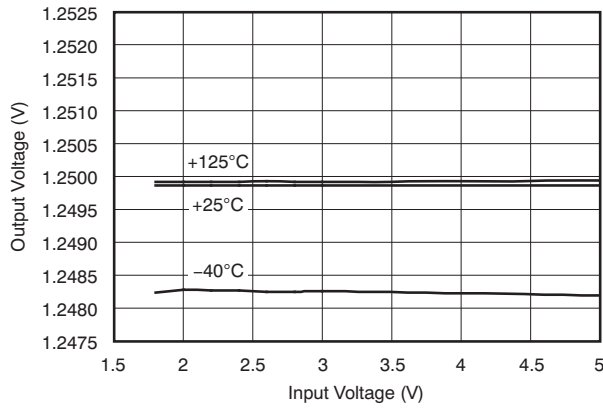

Figure 7.

OUTPUT VOLTAGE vs LOAD CURRENT

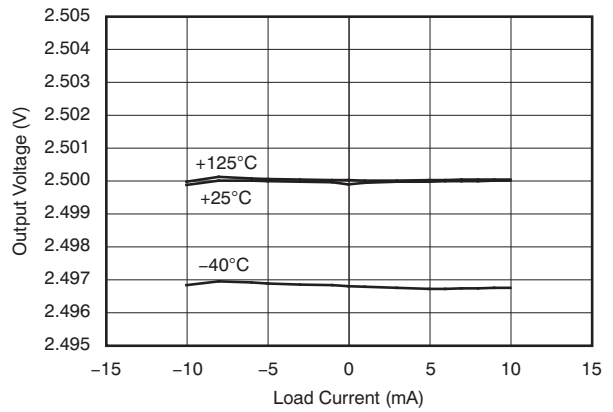

Figure 8.

0.1Hz TO 10Hz NOISE

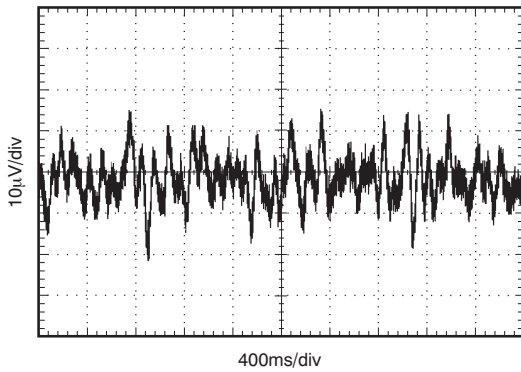

Figure 9.

OUTPUT VOLTAGE INITIAL ACCURACY

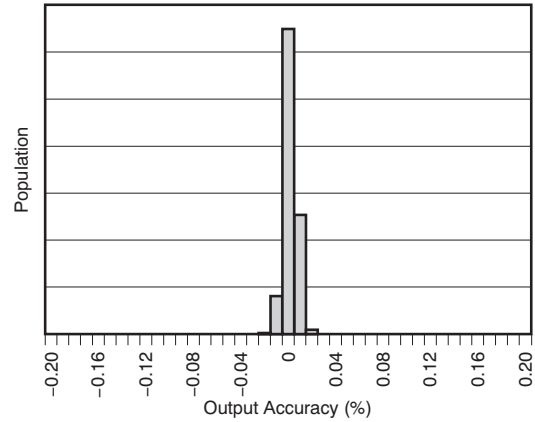

Figure 10.

**STEP RESPONSE
 $C_L = 0\text{pF}$, 5V STARTUP**

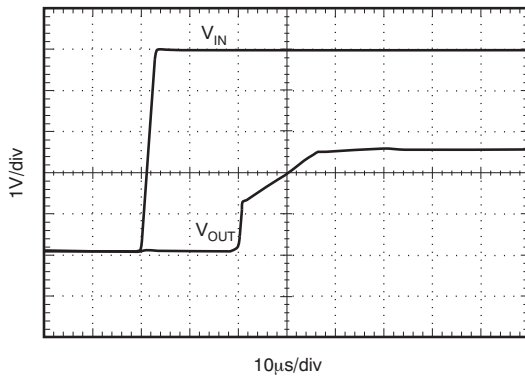

Figure 11.

**STEP RESPONSE
 $C_L = 1\mu\text{F}$**

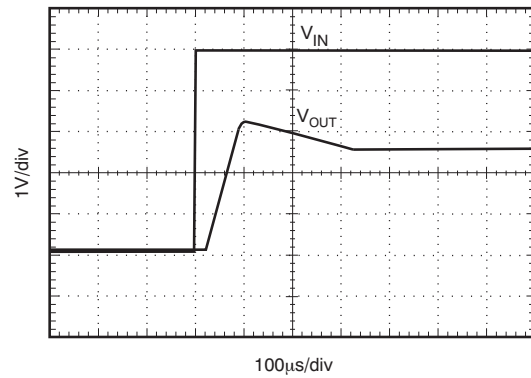
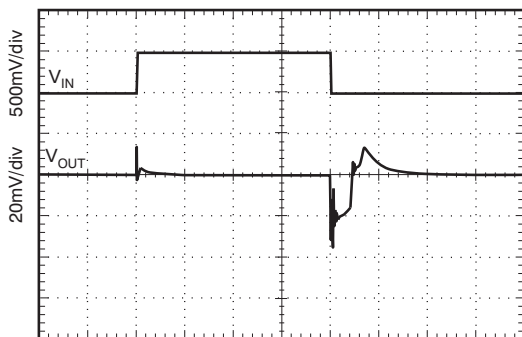

Figure 12.

TYPICAL CHARACTERISTICS (continued)

At $T_A = +25^\circ\text{C}$, $I_{\text{LOAD}} = 0\text{mA}$, $V_{\text{IN}} = +5\text{V}$ power supply, and REF3225 used for typical characteristics, unless otherwise noted.

LINE TRANSIENT
 $C_L = 0\text{pF}$



20 $\mu\text{s}/\text{div}$

Figure 13.

LINE TRANSIENT
 $C_L = 10\mu\text{F}$

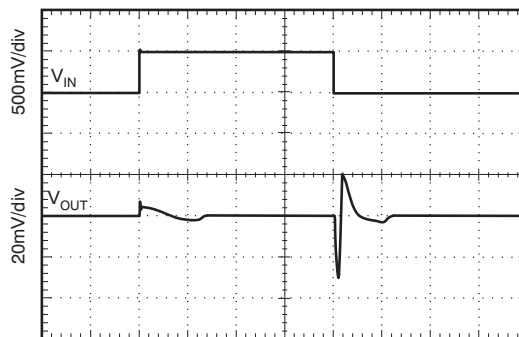

100 $\mu\text{s}/\text{div}$

Figure 14.

LOAD TRANSIENT
 $C_L = 0\text{pF}$, $\pm 10\text{mA}$ OUTPUT PULSE

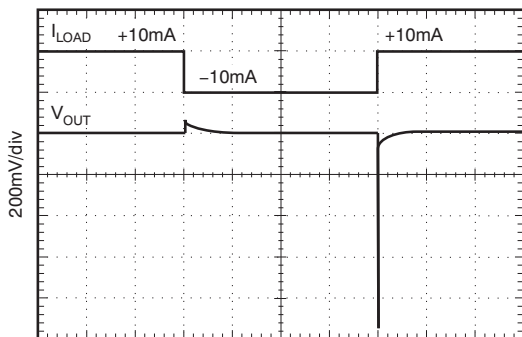

40 $\mu\text{s}/\text{div}$

Figure 15.

LOAD TRANSIENT
 $C_L = 1\mu\text{F}$, $\pm 10\text{mA}$ OUTPUT PULSE

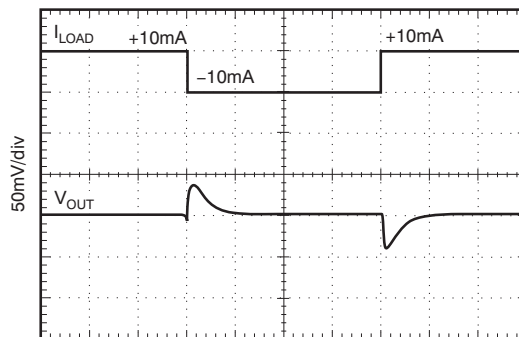

40 $\mu\text{s}/\text{div}$

Figure 16.

LOAD TRANSIENT
 $C_L = 0\text{pF}$, $\pm 1\text{mA}$ OUTPUT PULSE

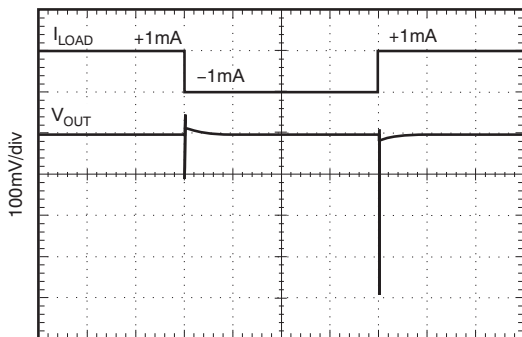

40 $\mu\text{s}/\text{div}$

Figure 17.

LOAD TRANSIENT
 $C_L = 1\mu\text{F}$, $\pm 1\text{mA}$ OUTPUT PULSE

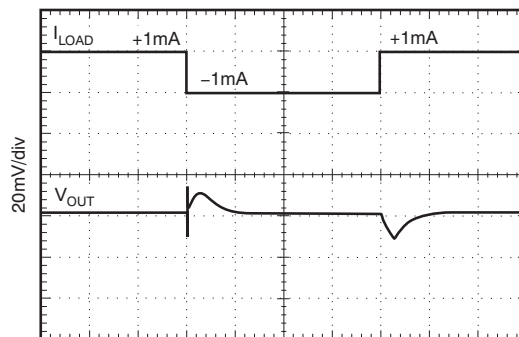

40 $\mu\text{s}/\text{div}$

Figure 18.

TYPICAL CHARACTERISTICS (continued)

At $T_A = +25^\circ\text{C}$, $I_{\text{LOAD}} = 0\text{mA}$, $V_{\text{IN}} = +5\text{V}$ power supply, and REF3225 used for typical characteristics, unless otherwise noted.

LONG-TERM STABILITY (32 Units)

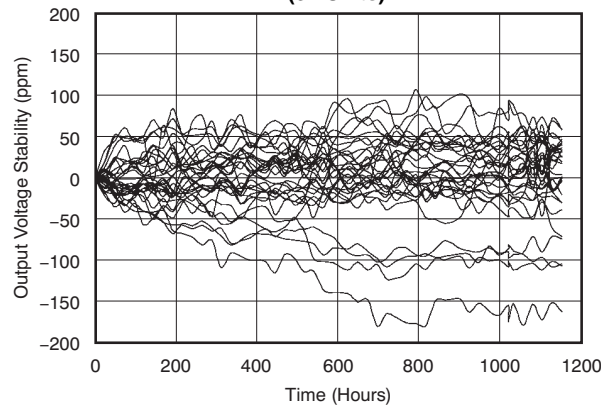

Figure 19.

THEORY OF OPERATION

GENERAL DESCRIPTION

The REF32xx is a family of CMOS, precision bandgap voltage references. Figure 20 shows the basic bandgap topology. Transistors Q_1 and Q_2 are biased so that the current density of Q_1 is greater than that of Q_2 . The difference of the two base-emitter voltages ($V_{be1} - V_{be2}$) has a positive temperature coefficient and is forced across resistor R_1 . This voltage is amplified and added to the base-emitter voltage of Q_2 , which has a negative temperature coefficient. The resulting output voltage is virtually independent of temperature.

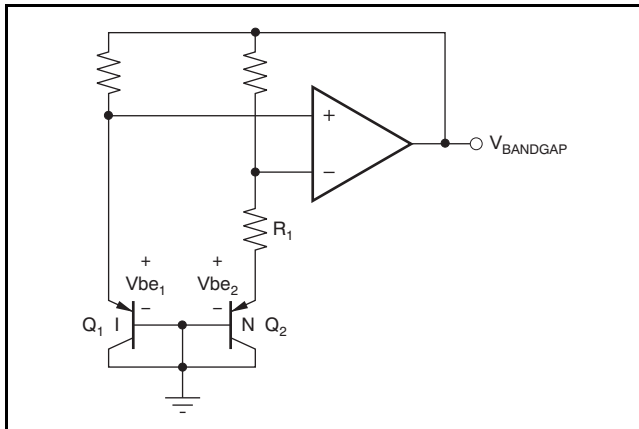

Figure 20. Simplified Schematic of Bandgap Reference

APPLICATION INFORMATION

The REF32xx does not require a load capacitor and is stable with any capacitive load. Figure 21 shows typical connections required for operation of the REF32xx. A supply bypass capacitor of $0.47\mu\text{F}$ is recommended.

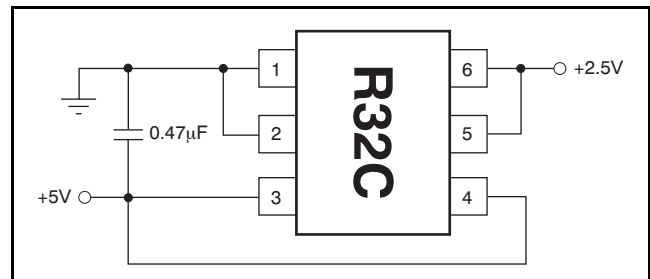

Figure 21. Typical Operating Connections for the REF3225

SUPPLY VOLTAGE

The REF32xx family of references features an extremely low dropout voltage. With the exception of the REF3212, which has a minimum supply requirement of 1.8V, these references can be operated with a supply of only 5mV above the output voltage in an unloaded condition. For loaded conditions, a typical dropout voltage versus load is shown in the Typical Characteristic curves.

The REF32xx also features a low quiescent current of 100µA, with a maximum quiescent current over temperature of just 135µA. The quiescent current typically changes less than 2µA over the entire supply range, as shown in Figure 22.

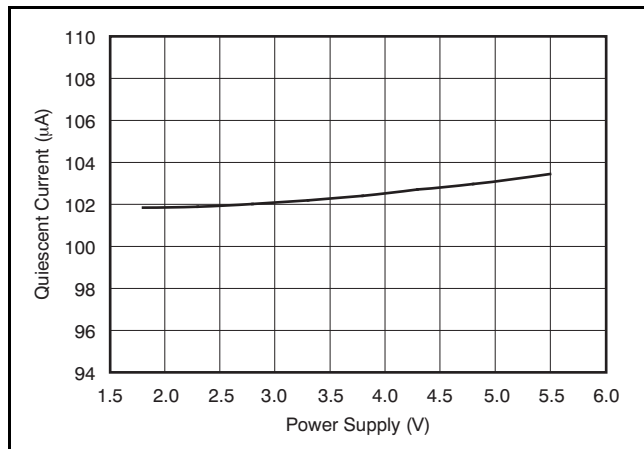

Figure 22. Supply Current vs Supply Voltage

Supply voltages below the specified levels can cause the REF32xx to momentarily draw currents greater than the typical quiescent current. This momentary current draw can be prevented by using a power supply with a fast rising edge and low output impedance.

For optimal startup when the IN pin and ENABLE pin are tied together, keep the input voltage rise time less than or equal to 2ms. For rise times greater than 2ms, the ENABLE pin must be kept below 0.7V until the voltage at the IN pin has reached the minimum operating voltage. One way to control the voltage at the ENABLE pin is with an additional RC filter, such as that shown in Figure 23. The RC filter must hold the voltage at the ENABLE pin below the threshold voltage until the voltage at the input pin has reached the minimum operating voltage.

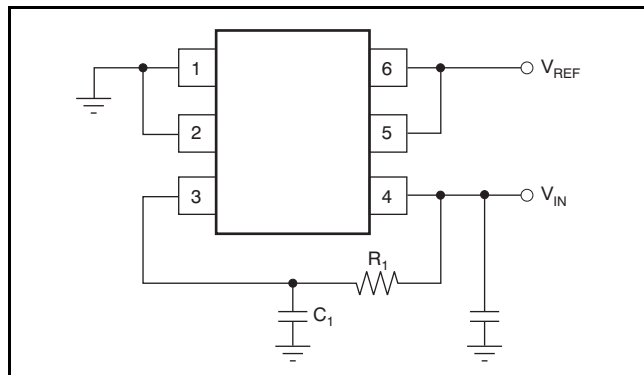

Figure 23. Application Circuit to Control the REF32xx ENABLE Pin

The RC filter in Figure 23 can be used as a starting point for the REF3240. The values for R_1 and C_1 have been calculated so that the voltage at the ENABLE pin reaches 0.7V after the input voltage has reached 4.15V; Table 1 lists these values. For output voltage options other than 4.096V, the RC filter can be made faster.

Table 1. Recommended R_1 and C_1 Values for the REF3240

RISE TIME	R_1 VALUE	C_1 VALUE
2ms	150kΩ	100nF
5ms	150kΩ	220nF
10ms	330kΩ	220nF
20ms	390kΩ	330nF
50ms	680kΩ	470nF
100ms	680kΩ	1000nF

In this document, rise time is defined as the time until an exponential input signal reaches 90% of its final voltage. For example, the 2ms value shown in Table 1 is valid for an end value of 5V.

If the input voltage has a different shape or the end value is not 5V, then the time until the minimum dropout voltage has been reached should be used to decide if the IN and ENABLE pins can be tied together. Table 2 lists these times.

Table 2. Minimum Dropout Voltage Times

DEVICE	TIME
REF3212	0.4ms
REF3220	0.5ms
REF3225	0.7ms
REF3230	0.9ms
REF3233	1.0ms
REF3240	1.6ms

Note that because the leakage current of the EN pin is in the range of a few nA, it can be disregarded in most applications.

SHUTDOWN

The REF32xx can be placed in a low-power mode by pulling the ENABLE/SHUTDOWN pin low. When in Shutdown mode, the output of the REF32xx becomes a resistive load to ground. The value of the load depends on the model, and ranges from approximately 100kΩ to 400kΩ.

THERMAL HYSTERESIS

Thermal hysteresis for the REF32xx is defined as the change in output voltage after operating the device at +25°C, cycling the device through the specified temperature range, and returning to +25°C. It can be expressed as:

$$V_{\text{HYST}} = \left(\frac{V_{\text{PRE}} - V_{\text{POST}}}{V_{\text{NOM}}} \right) \times 10^6 (\text{ppm})$$

Where:

V_{HYST} = thermal hysteresis (in units of ppm).

V_{NOM} = the specified output voltage.

V_{PRE} = output voltage measured at +25°C pretemperature cycling.

V_{POST} = output voltage measured after the device has been cycled through the specified temperature range of –40°C to +125°C and returned to +25°C. (1)

TEMPERATURE DRIFT

The REF32xx is designed to exhibit minimal drift error, which is defined as the change in output voltage over varying temperature. The drift is calculated using the box method, as described by Equation 2:

$$\text{Drift} = \left(\frac{V_{\text{OUTMAX}} - V_{\text{OUTMIN}}}{V_{\text{OUT}} \times \text{Temp Range}} \right) \times 10^6 (\text{ppm}) \quad (2)$$

The REF32xx features a typical drift coefficient of 4ppm/°C from 0°C to +125°C—the primary temperature range for many applications. For the extended industrial temperature range of –40°C to +125°C, the REF32xx family drift increases to a typical value of 10.5ppm/°C.

NOISE PERFORMANCE

Typical 0.1Hz to 10Hz voltage noise can be seen in the Typical Characteristic curve, 0.1Hz to 10Hz Voltage Noise. The noise voltage of the REF32xx increases with output voltage and operating temperature. Additional filtering can be used to improve output noise levels, although care should be taken to ensure the output impedance does not degrade AC performance.

LONG-TERM STABILITY

Long-term stability refers to the change of the output voltage of a reference over a period of months or years. This effect lessens as time progresses, as is shown by the long-term stability Typical Characteristic curves. The typical drift value for the REF32xx is 55ppm from 0 to 1000 hours. This parameter is characterized by measuring 30 units at regular intervals for a period of 1000 hours.

LOAD REGULATION

Load regulation is defined as the change in output voltage as a result of changes in load current. The load regulation of the REF32xx is measured using force and sense contacts, as shown in Figure 24.

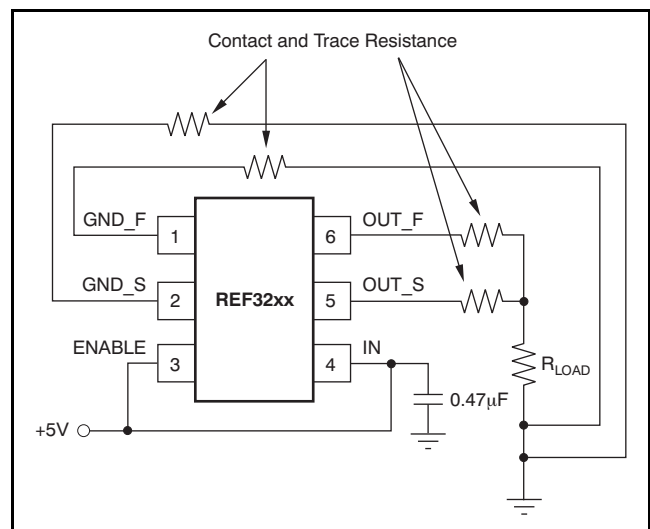

Figure 24. Accurate Load Regulation of REF32xx

The force and sense lines can be used to effectively eliminate the impact of contact and trace resistance, resulting in accurate voltage at the load. By connecting the force and sense lines at the load, the REF32xx compensates for the contact and trace resistances because it measures and adjusts the voltage actually delivered at the load.

The GND_S pin is connected to the internal ground of the device through ESD protection diodes. Because of that connection, the maximum differential voltage between the GND_S and GND_F pins must be kept below 200mV to prevent these diodes from unintentionally turning on.

APPLICATION CIRCUITS

NEGATIVE REFERENCE VOLTAGE

For applications requiring a negative and positive reference voltage, the REF32xx and OPA735 can be used to provide a dual-supply reference from a $\pm 5V$ supply. Figure 25 shows the REF3225 used to provide a $\pm 2.5V$ supply reference voltage. The low drift performance of the REF32xx complements the low offset voltage and zero drift of the OPA735 to provide an accurate solution for split-supply applications. Care must be taken to match the temperature coefficients of R_1 and R_2 .

DATA ACQUISITION

Data acquisition systems often require stable voltage references to maintain accuracy. The REF32xx family features stability and a wide range of voltages suitable for most microcontrollers and data converters. Figure 26, Figure 27, and Figure 28 show basic data acquisition systems.

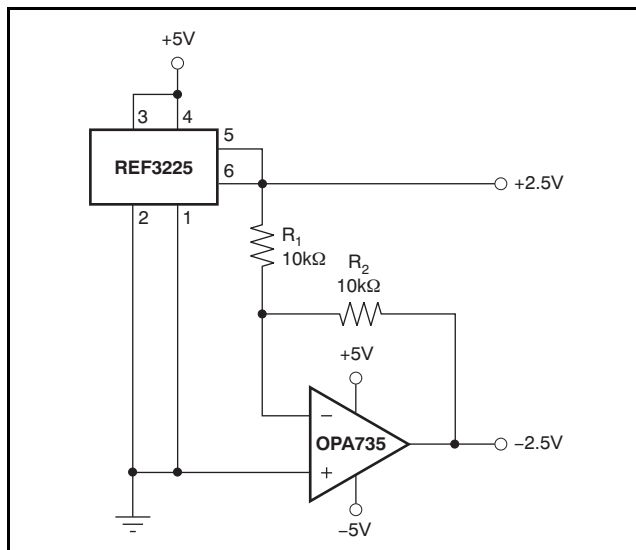

NOTE:: Bypass capacitor is not shown.

Figure 25. REF3225 Combined with OPA735 to Create Positive and Negative Reference Voltages

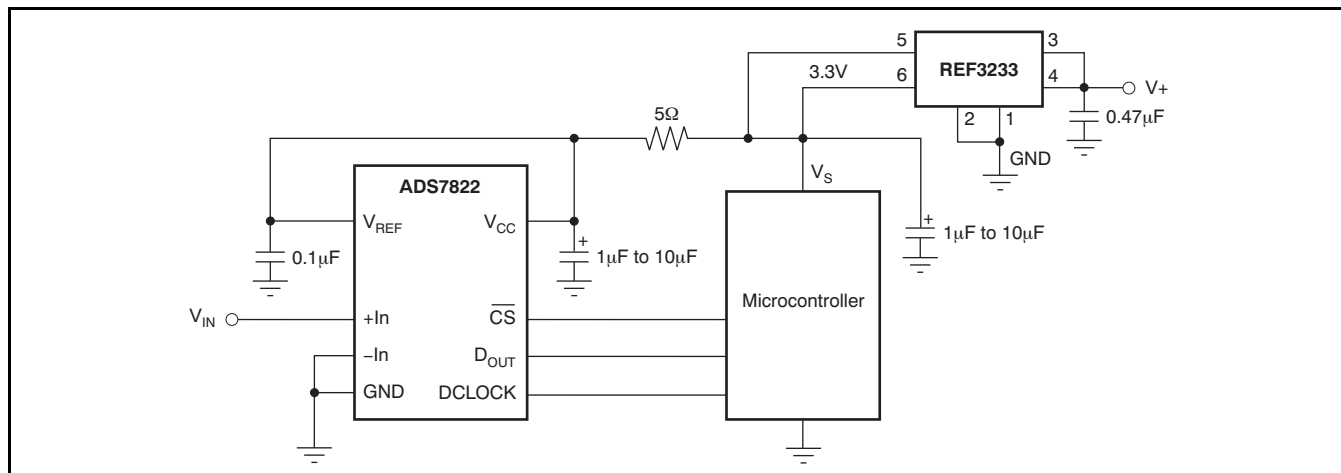

Figure 26. Basic Data Acquisition System 1

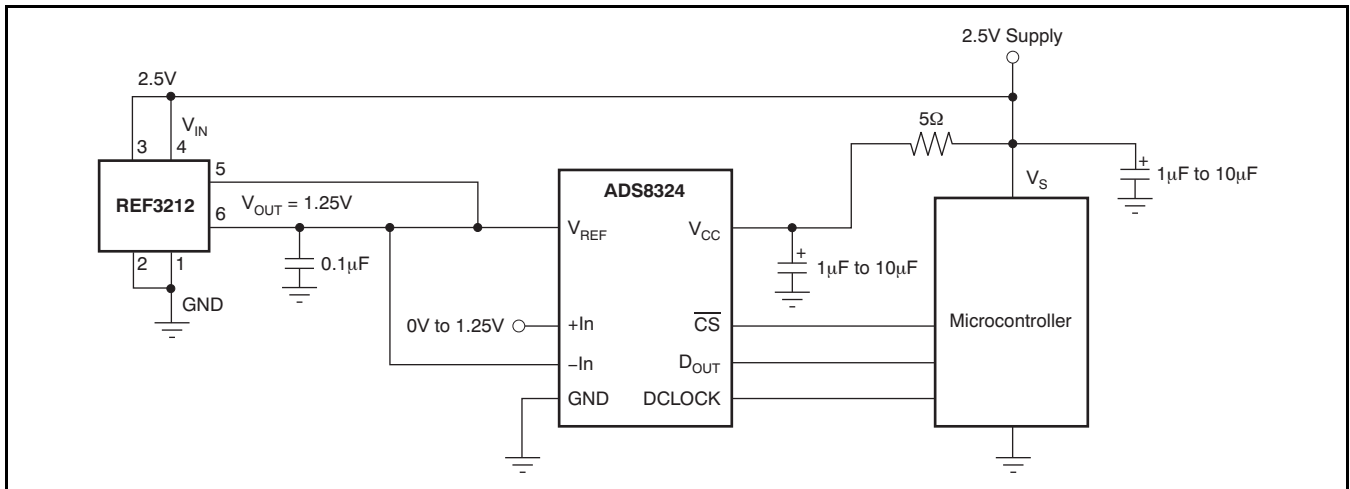

Figure 27. Basic Data Acquisition System 2

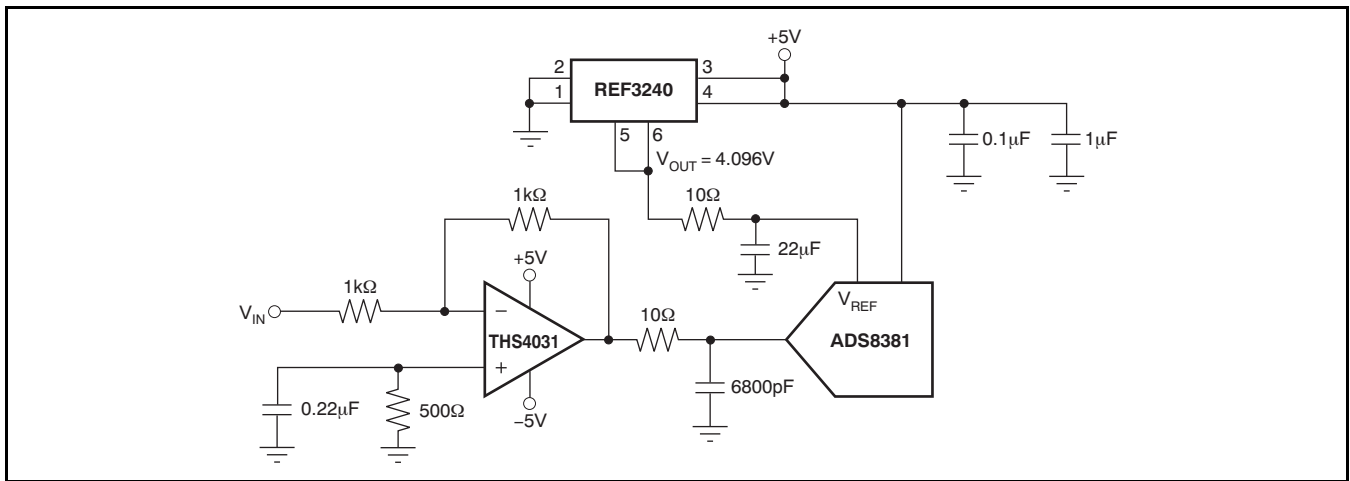

Figure 28. REF3240 Provides an Accurate Reference for Driving the ADS8381

REVISION HISTORY

NOTE: Page numbers for previous revisions may differ from page numbers in the current version.

Changes from Revision B (February 2006) to Revision C	Page
• Added Pin Descriptions table	2
• Added note to Enable/Shutdown parameter	4
• Changed the minimum voltage for Enable/Shutdown with reference active from $(0.75 \times V_{IN})$ to 1.5	4
• Changed Current test condition from from $(0.75 \times V_{IN})$ to (1.5V)	4
• Added text, two tables, and one figure to Supply Voltage section	8
• Changed pin 3 in Figure 24 from SHDN to ENABLE (typo)	10
• Added paragraph to Load Regulation section	10

PACKAGING INFORMATION

Orderable Device	Status (1)	Package Type	Package Drawing	Pins	Package Qty	Eco Plan (2)	Lead finish/ Ball material (6)	MSL Peak Temp (3)	Op Temp (°C)	Device Marking (4/5)	Samples
REF3212AIDBVR	ACTIVE	SOT-23	DBV	6	3000	RoHS & Green	NIPDAU	Level-2-260C-1 YEAR	-40 to 125	R32A	Samples
REF3212AIDBVT	ACTIVE	SOT-23	DBV	6	250	RoHS & Green	NIPDAU	Level-2-260C-1 YEAR	-40 to 125	R32A	Samples
REF3220AIDBVR	ACTIVE	SOT-23	DBV	6	3000	RoHS & Green	NIPDAU	Level-2-260C-1 YEAR	-40 to 125	R32B	Samples
REF3220AIDBVT	ACTIVE	SOT-23	DBV	6	250	RoHS & Green	NIPDAU	Level-2-260C-1 YEAR	-40 to 125	R32B	Samples
REF3225AIDBVR	NRND	SOT-23	DBV	6	3000	RoHS & Green	NIPDAU	Level-2-260C-1 YEAR	-40 to 125	R32C	
REF3225AIDBVT	NRND	SOT-23	DBV	6	250	RoHS & Green	NIPDAU	Level-2-260C-1 YEAR	-40 to 125	R32C	
REF3230AIDBVR	NRND	SOT-23	DBV	6	3000	RoHS & Green	NIPDAU	Level-2-260C-1 YEAR	-40 to 125	R32D	
REF3230AIDBVT	NRND	SOT-23	DBV	6	250	RoHS & Green	NIPDAU	Level-2-260C-1 YEAR	-40 to 125	R32D	
REF3233AIDBVR	NRND	SOT-23	DBV	6	3000	RoHS & Green	NIPDAU	Level-2-260C-1 YEAR	-40 to 125	R32E	
REF3233AIDBVT	NRND	SOT-23	DBV	6	250	RoHS & Green	NIPDAU	Level-2-260C-1 YEAR	-40 to 125	R32E	
REF3240AIDBVR	NRND	SOT-23	DBV	6	3000	RoHS & Green	NIPDAU	Level-2-260C-1 YEAR	-40 to 125	R32F	
REF3240AIDBVT	NRND	SOT-23	DBV	6	250	RoHS & Green	NIPDAU	Level-2-260C-1 YEAR	-40 to 125	R32F	

(1) The marketing status values are defined as follows:

ACTIVE: Product device recommended for new designs.

LIFEBUY: TI has announced that the device will be discontinued, and a lifetime-buy period is in effect.

NRND: Not recommended for new designs. Device is in production to support existing customers, but TI does not recommend using this part in a new design.

PREVIEW: Device has been announced but is not in production. Samples may or may not be available.

OBSELETE: TI has discontinued the production of the device.

(2) **RoHS:** TI defines "RoHS" to mean semiconductor products that are compliant with the current EU RoHS requirements for all 10 RoHS substances, including the requirement that RoHS substance do not exceed 0.1% by weight in homogeneous materials. Where designed to be soldered at high temperatures, "RoHS" products are suitable for use in specified lead-free processes. TI may reference these types of products as "Pb-Free".

RoHS Exempt: TI defines "RoHS Exempt" to mean products that contain lead but are compliant with EU RoHS pursuant to a specific EU RoHS exemption.

Green: TI defines "Green" to mean the content of Chlorine (Cl) and Bromine (Br) based flame retardants meet JS709B low halogen requirements of <=1000ppm threshold. Antimony trioxide based flame retardants must also meet the <=1000ppm threshold requirement.

(3) MSL, Peak Temp. - The Moisture Sensitivity Level rating according to the JEDEC industry standard classifications, and peak solder temperature.

(4) There may be additional marking, which relates to the logo, the lot trace code information, or the environmental category on the device.

(5) Multiple Device Markings will be inside parentheses. Only one Device Marking contained in parentheses and separated by a "~" will appear on a device. If a line is indented then it is a continuation of the previous line and the two combined represent the entire Device Marking for that device.

(6) Lead finish/Ball material - Orderable Devices may have multiple material finish options. Finish options are separated by a vertical ruled line. Lead finish/Ball material values may wrap to two lines if the finish value exceeds the maximum column width.

Important Information and Disclaimer:The information provided on this page represents TI's knowledge and belief as of the date that it is provided. TI bases its knowledge and belief on information provided by third parties, and makes no representation or warranty as to the accuracy of such information. Efforts are underway to better integrate information from third parties. TI has taken and continues to take reasonable steps to provide representative and accurate information but may not have conducted destructive testing or chemical analysis on incoming materials and chemicals. TI and TI suppliers consider certain information to be proprietary, and thus CAS numbers and other limited information may not be available for release.

In no event shall TI's liability arising out of such information exceed the total purchase price of the TI part(s) at issue in this document sold by TI to Customer on an annual basis.

OTHER QUALIFIED VERSIONS OF REF3212, REF3220, REF3225, REF3230, REF3240 :

- Enhanced Product : [REF3212-EP](#), [REF3220-EP](#), [REF3225-EP](#), [REF3230-EP](#), [REF3240-EP](#)

NOTE: Qualified Version Definitions:

- Enhanced Product - Supports Defense, Aerospace and Medical Applications

TAPE AND REEL INFORMATION

QUADRANT ASSIGNMENTS FOR PIN 1 ORIENTATION IN TAPE

*All dimensions are nominal

Device	Package Type	Package Drawing	Pins	SPQ	Reel Diameter (mm)	Reel Width W1 (mm)	A0 (mm)	B0 (mm)	K0 (mm)	P1 (mm)	W (mm)	Pin1 Quadrant
REF3212AIDBVR	SOT-23	DBV	6	3000	178.0	9.0	3.23	3.17	1.37	4.0	8.0	Q3
REF3212AIDBVT	SOT-23	DBV	6	250	178.0	9.0	3.23	3.17	1.37	4.0	8.0	Q3
REF3220AIDBVR	SOT-23	DBV	6	3000	178.0	9.0	3.23	3.17	1.37	4.0	8.0	Q3
REF3220AIDBVT	SOT-23	DBV	6	250	178.0	9.0	3.23	3.17	1.37	4.0	8.0	Q3
REF3225AIDBVR	SOT-23	DBV	6	3000	178.0	9.0	3.23	3.17	1.37	4.0	8.0	Q3
REF3225AIDBVT	SOT-23	DBV	6	250	178.0	9.0	3.23	3.17	1.37	4.0	8.0	Q3
REF3230AIDBVR	SOT-23	DBV	6	3000	178.0	9.0	3.23	3.17	1.37	4.0	8.0	Q3
REF3230AIDBVT	SOT-23	DBV	6	250	178.0	9.0	3.23	3.17	1.37	4.0	8.0	Q3
REF3233AIDBVR	SOT-23	DBV	6	3000	178.0	9.0	3.23	3.17	1.37	4.0	8.0	Q3
REF3233AIDBVT	SOT-23	DBV	6	250	178.0	9.0	3.23	3.17	1.37	4.0	8.0	Q3
REF3240AIDBVR	SOT-23	DBV	6	3000	178.0	9.0	3.23	3.17	1.37	4.0	8.0	Q3
REF3240AIDBVT	SOT-23	DBV	6	250	178.0	9.0	3.23	3.17	1.37	4.0	8.0	Q3

TAPE AND REEL BOX DIMENSIONS

*All dimensions are nominal

Device	Package Type	Package Drawing	Pins	SPQ	Length (mm)	Width (mm)	Height (mm)
REF3212AIDBVR	SOT-23	DBV	6	3000	445.0	220.0	345.0
REF3212AIDBVT	SOT-23	DBV	6	250	445.0	220.0	345.0
REF3220AIDBVR	SOT-23	DBV	6	3000	445.0	220.0	345.0
REF3220AIDBVT	SOT-23	DBV	6	250	445.0	220.0	345.0
REF3225AIDBVR	SOT-23	DBV	6	3000	445.0	220.0	345.0
REF3225AIDBVT	SOT-23	DBV	6	250	445.0	220.0	345.0
REF3230AIDBVR	SOT-23	DBV	6	3000	445.0	220.0	345.0
REF3230AIDBVT	SOT-23	DBV	6	250	445.0	220.0	345.0
REF3233AIDBVR	SOT-23	DBV	6	3000	445.0	220.0	345.0
REF3233AIDBVT	SOT-23	DBV	6	250	445.0	220.0	345.0
REF3240AIDBVR	SOT-23	DBV	6	3000	445.0	220.0	345.0
REF3240AIDBVT	SOT-23	DBV	6	250	445.0	220.0	345.0

DBV0006A



PACKAGE OUTLINE

SOT-23 - 1.45 mm max height

SMALL OUTLINE TRANSISTOR

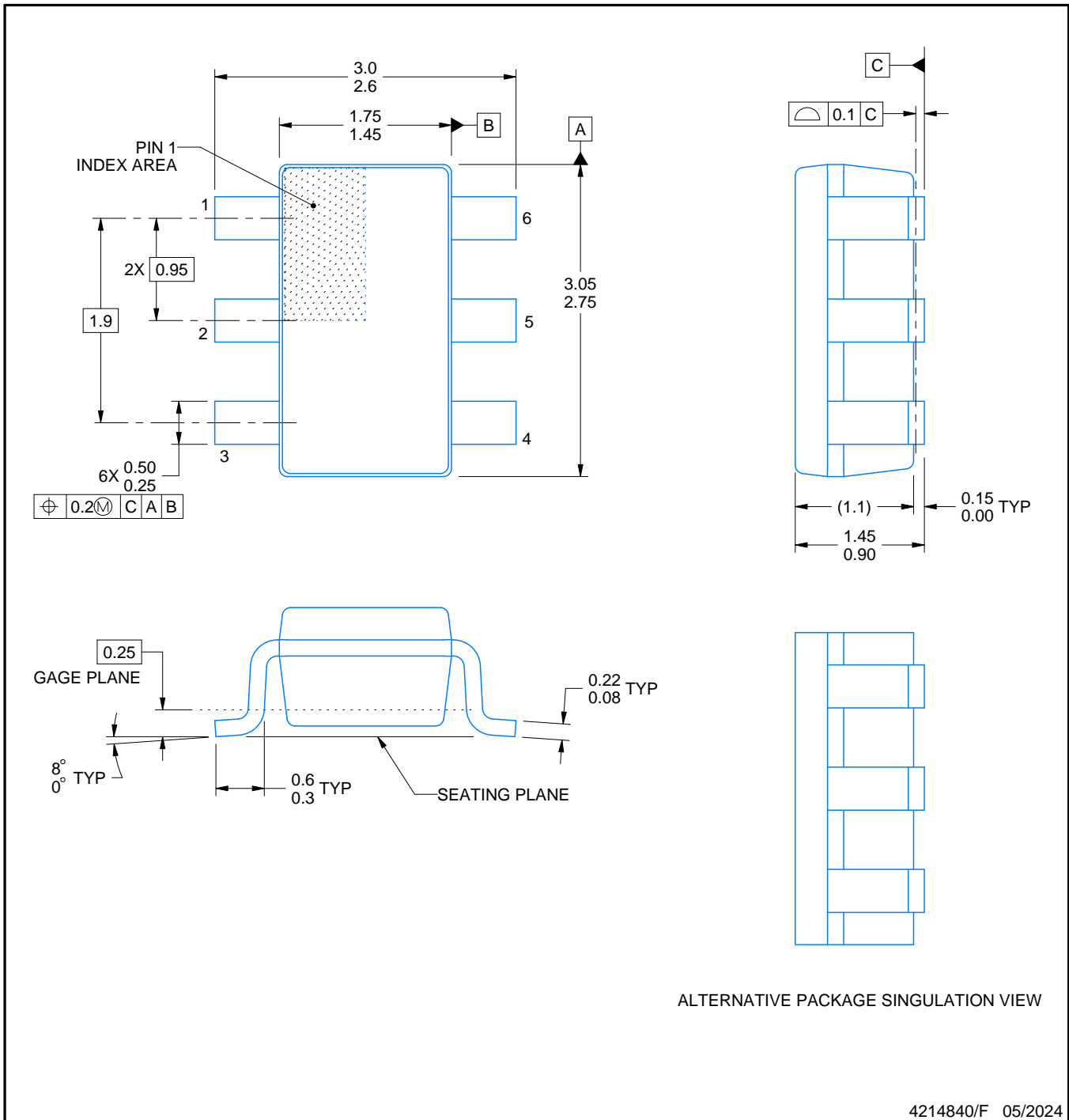

ALTERNATIVE PACKAGE SINGULATION VIEW

4214840/F 05/2024

NOTES:

1. All linear dimensions are in millimeters. Any dimensions in parenthesis are for reference only. Dimensioning and tolerancing per ASME Y14.5M.
2. This drawing is subject to change without notice.
3. Body dimensions do not include mold flash or protrusion. Mold flash and protrusion shall not exceed 0.25 per side.
4. Leads 1,2,3 may be wider than leads 4,5,6 for package orientation.
5. Reference JEDEC MO-178.

EXAMPLE BOARD LAYOUT

DBV0006A

SOT-23 - 1.45 mm max height

SMALL OUTLINE TRANSISTOR

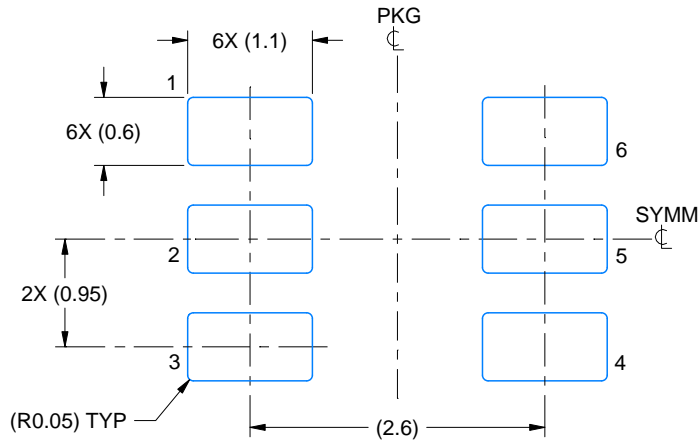

LAND PATTERN EXAMPLE
EXPOSED METAL SHOWN
SCALE:15X

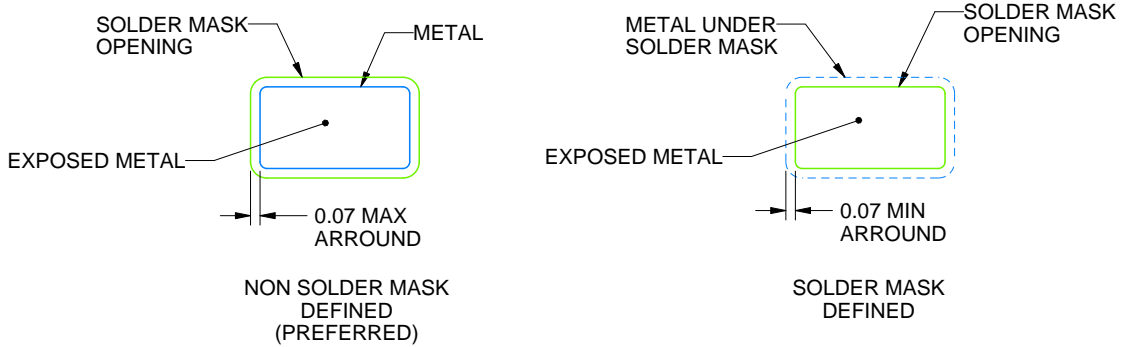

SOLDER MASK DETAILS

4214840/F 05/2024

NOTES: (continued)

- 6. Publication IPC-7351 may have alternate designs.
- 7. Solder mask tolerances between and around signal pads can vary based on board fabrication site.

EXAMPLE STENCIL DESIGN

DBV0006A

SOT-23 - 1.45 mm max height

SMALL OUTLINE TRANSISTOR

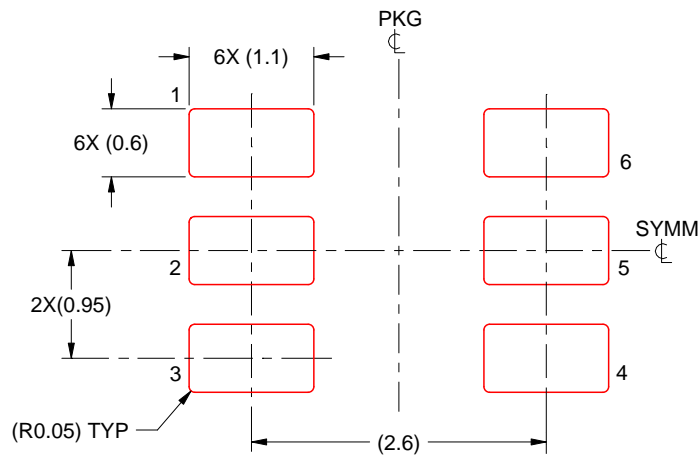

SOLDER PASTE EXAMPLE
BASED ON 0.125 mm THICK STENCIL
SCALE:15X

4214840/F 05/2024

NOTES: (continued)

8. Laser cutting apertures with trapezoidal walls and rounded corners may offer better paste release. IPC-7525 may have alternate design recommendations.
9. Board assembly site may have different recommendations for stencil design.

IMPORTANT NOTICE AND DISCLAIMER

TI PROVIDES TECHNICAL AND RELIABILITY DATA (INCLUDING DATA SHEETS), DESIGN RESOURCES (INCLUDING REFERENCE DESIGNS), APPLICATION OR OTHER DESIGN ADVICE, WEB TOOLS, SAFETY INFORMATION, AND OTHER RESOURCES "AS IS" AND WITH ALL FAULTS, AND DISCLAIMS ALL WARRANTIES, EXPRESS AND IMPLIED, INCLUDING WITHOUT LIMITATION ANY IMPLIED WARRANTIES OF MERCHANTABILITY, FITNESS FOR A PARTICULAR PURPOSE OR NON-INFRINGEMENT OF THIRD PARTY INTELLECTUAL PROPERTY RIGHTS.

These resources are intended for skilled developers designing with TI products. You are solely responsible for (1) selecting the appropriate TI products for your application, (2) designing, validating and testing your application, and (3) ensuring your application meets applicable standards, and any other safety, security, regulatory or other requirements.

These resources are subject to change without notice. TI grants you permission to use these resources only for development of an application that uses the TI products described in the resource. Other reproduction and display of these resources is prohibited. No license is granted to any other TI intellectual property right or to any third party intellectual property right. TI disclaims responsibility for, and you will fully indemnify TI and its representatives against, any claims, damages, costs, losses, and liabilities arising out of your use of these resources.

TI's products are provided subject to [TI's Terms of Sale](#) or other applicable terms available either on [ti.com](https://www.ti.com) or provided in conjunction with such TI products. TI's provision of these resources does not expand or otherwise alter TI's applicable warranties or warranty disclaimers for TI products.

TI objects to and rejects any additional or different terms you may have proposed.

Mailing Address: Texas Instruments, Post Office Box 655303, Dallas, Texas 75265
Copyright © 2024, Texas Instruments Incorporated

Looking for pricing, stock, or lifecycle information?

Click below to explore more details on WIN SOURCE:

- ⊖ [View AGL030V5-VQG100 on WIN SOURCE](#)
- ⊖ [Microchip Technology](#) Information

Optimize Your Supply Chain with WIN SOURCE Solutions

- ✓ Global Sourcing Solution
- ✓ Obsolete Management
- ✓ Cost Control Management
- ✓ Shortage Management
- ✓ Alternative Solution
- ✓ Excess Inventory Management