



**THE DATASHEET OF
PN7150B0HN/C11002E**



PN7150

High performance NFC controller with integrated firmware, supporting all NFC Forum modes

Rev. 4.2 — 2 February 2024

Product data sheet



1 Introduction

This document describes the functionality and electrical specification of the NFC Controller PN7150.

Additional documents describing the product functionality further are available for design-in support. Refer to the references listed in this document to get access to the full documentation provided by NXP.



2 General description

Plug'n play and high-performance full NFC solution PN7150 is a full NFC controller solution with integrated firmware and NCI interface designed for contactless communication at 13.56 MHz. It is compatible with NFC forum requirements.

PN7150 is designed based on learnings from previous NXP NFC device generation. It is the ideal solution for rapidly integrating NFC technology in any application, especially those running O/S environment like Linux and Android, reducing Bill of Material (BOM) size and cost, thanks to:

- Full NFC forum compliancy (see [1]) with small form factor antenna
- Embedded NFC firmware providing all NFC protocols as pre-integrated feature
- Direct connection to the main host or microcontroller, by I²C-bus physical and NCI protocol
- Ultra-low power consumption in polling loop mode
- Highly efficient integrated power management unit (PMU) allowing direct supply from a battery

PN7150 embeds a new generation RF contactless front-end supporting various transmission modes according to NFCIP-1 and NFCIP-2, ISO/IEC 14443, ISO/IEC 15693, MIFARE Classic IC-based card and FeliCa card specifications. It embeds an Arm Cortex-M0 microcontroller core loaded with the integrated firmware supporting the NCI 1.0 host communication. It also allows to provide a higher output power by supplying the transmitter output stage from 3.0 V to 4.75 V.

The contactless front-end design brings a major performance step-up with on one hand a higher sensitivity and on the other hand the capability to work in active load modulation communication enabling the support of small antenna form factor.

Figure 1 lists the supported transmission modes. For contactless card functionality, the PN7150 can act autonomously if previously configured by the host in such a manner.

PN7150 integrated firmware provides an easy integration and validation cycle as all the NFC real-time constraints, protocols and device discovery (polling loop) are being taken care internally. In few NCI commands, host SW can configure the PN7150 to notify for card or peer detection and start communicating with them.

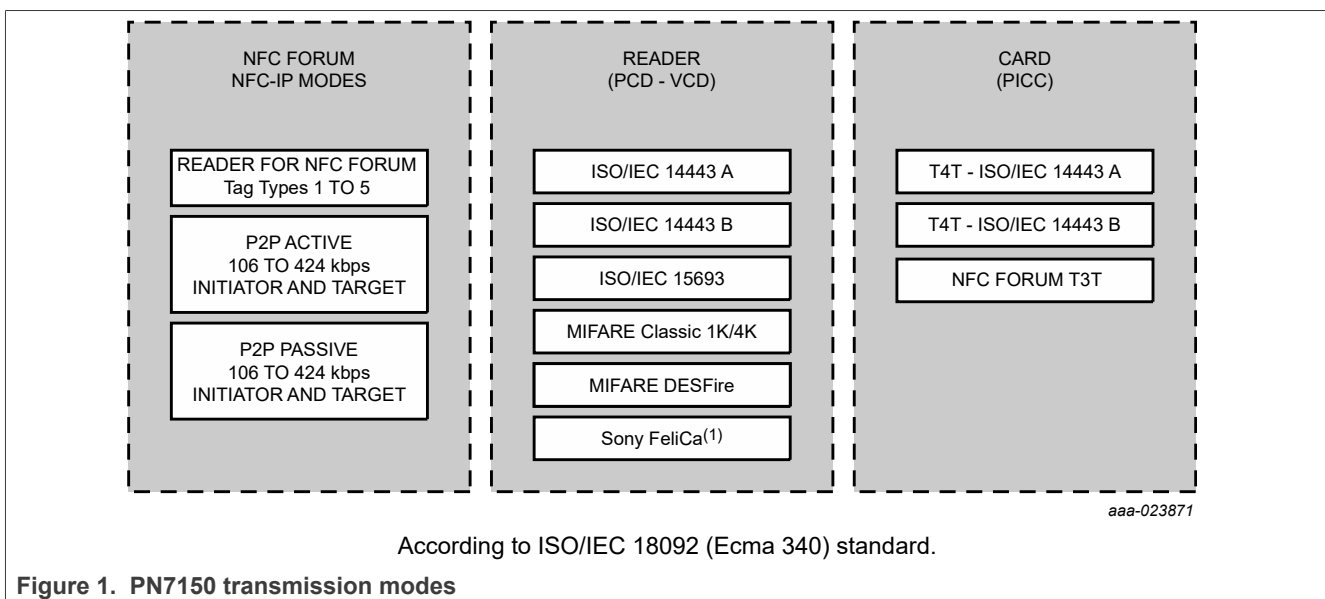

3 Features and benefits

- Includes NXP ISO/IEC14443-A and Innovatron ISO/IEC14443-B intellectual property licensing rights
- Arm Cortex-M0 microcontroller core
- Highly integrated demodulator and decoder
- Buffered output drivers to connect an antenna with minimum number of external components
- Integrated RF level detector
- Integrated Polling Loop for automatic device discovery
- RF protocols supported
 - NFCIP-1, NFCIP-2 protocol (see [\[8\]](#) and [\[11\]](#))
 - ISO/IEC 14443A, ISO/IEC 14443B PICC, NFC Forum T4T modes via host interface (see [\[3\]](#))
 - NFC Forum T3T via host interface
 - ISO/IEC 14443A, ISO/IEC 14443B PCD designed according to NFC Forum digital protocol T4T platform and ISO-DEP (see [\[1\]](#))
 - FeliCa PCD mode
 - MIFARE Classic PCD encryption mechanism (MIFARE Classic 1K/4K)
 - NFC Forum tag 1 to 5 (MIFARE Ultralight, Jewel, Open FeliCa tag, MIFARE DESFire) (see [\[1\]](#))
 - ISO/IEC 15693/ICODE VCD mode (see [\[9\]](#))
- Supported host interfaces
 - NCI protocol interface according to NFC Forum standardization (see [\[2\]](#))
 - I²C-bus High-speed mode (see [\[4\]](#))
- Integrated power management unit
 - Direct connection to a battery (2.3 V to 5.5 V voltage supply range)
 - Support different Hard Power-Down/Standby states activated by firmware
 - Autonomous mode when host is shut down
- Automatic wake-up via RF field, internal timer and I²C-bus interface
- Integrated non-volatile memory to store data and executable code for customization

4 Applications

- All devices requiring NFC functionality especially those running in an Android or Linux environment
- TVs, set-top boxes, blu-ray decoders, audio devices
- Home automation, gateways, wireless routers
- Home appliances
- Wearables, remote controls, healthcare, fitness
- Printers, IP phones, gaming consoles, accessories

5 Quick reference data

Table 1. Quick reference data

Symbol	Parameter	Conditions	Min	Typ	Max	Unit
V _{BAT}	battery supply voltage	Card Emulation and Passive Target; V _{SS} = 0 V	[1] [2] 2.3	-	5.5	V
		Reader, Active Initiator and Active Target; V _{SS} = 0 V	[1] [2] 2.7	-	5.5	V
V _{DD}	supply voltage	internal supply voltage	1.65	1.8	1.95	V
V _{DD(PAD)}	V _{DD(PAD)} supply voltage	supply voltage for host interface				
		• 1.8 V host supply; V _{SS} = 0 V	[1] 1.65	1.8	1.95	V
		• 3 V host supply; V _{SS} = 0 V	[1] 3.0	-	3.6	V
I _{BAT}	battery supply current	in Hard Power Down state; V _{BAT} = 3.6 V; T = 25 °C	[3] -	10	14	µA
		in Standby state; V _{BAT} = 3.6 V; T = 25 °C	-	20	-	µA
		in Monitor state; V _{BAT} = 2.75 V; T = 25 °C	-	-	14	µA
		in low-power polling loop; V _{BAT} = 3.6 V; T = 25 °C; loop time = 500 ms	[4] -	150	-	µA
		PCD mode at typical 3 V	[2] -	-	190	mA
I _{O(VDDPAD)}	output current on pin V _{DD(PAD)}	total current which can be pulled on V _{DD(PAD)} referenced outputs	-	-	15	mA
I _{th(Ilim)}	current limit threshold current	current limiter on V _{DD(TX)} pin; V _{DD(TX)} = 3.3 V	[2] -	180	-	mA
P _{tot}	total power dissipation	Reader; I _{VDD(TX)} = 100 mA; V _{BAT} = 5.5 V	-	-	420	mW
T _{amb}	ambient temperature	JEDEC PCB-0.5	-30	-	+85	°C

[1] V_{SS} represents V_{SS(PAD)} and V_{SS(TX)}.

[2] The antenna should be tuned not to exceed this current limit (the detuning effect when coupling with another device must be taken into account).

[3] External clock on NFC_CLK_XTAL1 must be LOW.

[4] See [10] for computing the power consumption as it depends on several parameters.

6 Versions

6.1 Version C11006

PN7150B0HN/C11006 contains a firmware update compared to the previous version.

The firmware version is 10.01.AE and contains the following new features and fixes:

- Anti tearing mechanism: An Anti tearing mechanism has been added. For details, please refer to the User Manual UM10936.
- A fix has been added that addresses a collision resolution problem for ISO 15693 tags in case there are multiple tags in the field.

This Firmware version does not support the standby mode. The standby is not supported, also during the polling sequence.

6.2 Version C11004

PN7150B0HN/C11004 has been withdrawn.

6.3 Version C11002

PN7150B0HN/C11002 and PN7150B0UK/C11002 is the initial released version.

The firmware version is 10.01.A0

High performance NFC controller with integrated firmware, supporting all NFC Forum modes

7 Ordering information

Table 2. Ordering information

Type number	Package		
	Name	Description	Version
PN7150B0HN/C110xx ^[1]	HVQFN40	plastic thermal enhanced very thin quad flat package; no leads; 40 terminals; body; 6 mm × 6 mm × 0.85 mm	SOT618-1
PN7150B0UK/C110xx ^[1]	WLCSP42	wafer level chip-scale package; 42 bumps; 2.88 mm × 2.80 mm × 0.54 mm (Backside coating included) Do not use for new designs. Planned for discontinuation.	SOT1459-1

[1] xx = firmware code variant

The product version C11006 does not support the standby mode. The standby is not supported, also during the polling sequence.

8 Marking HVQFN40

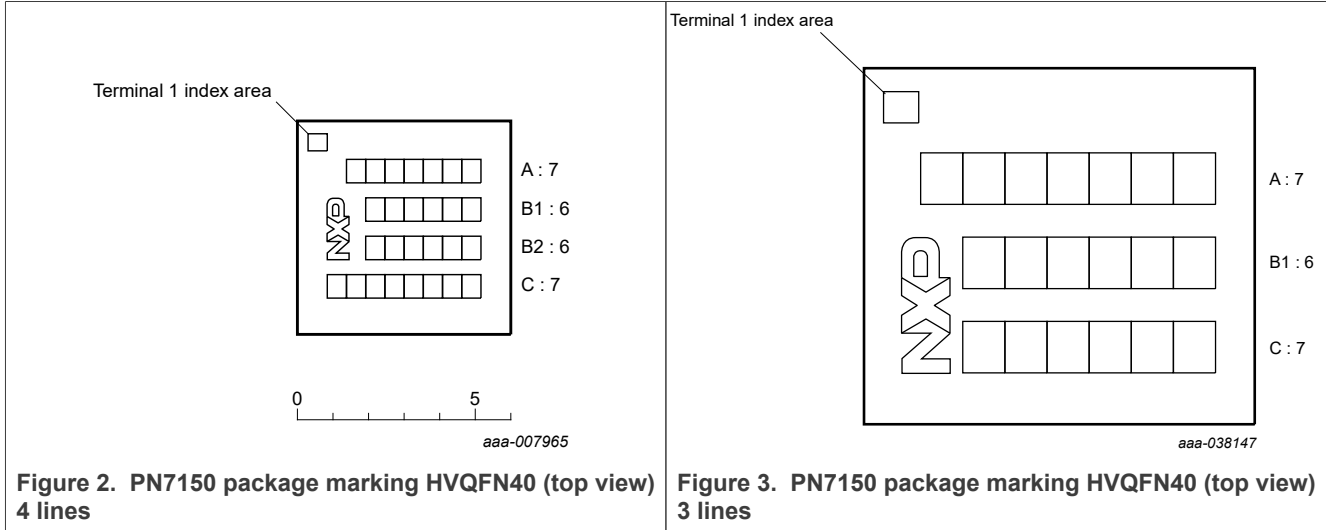

Figure 2. PN7150 package marking HVQFN40 (top view) 4 lines

Figure 3. PN7150 package marking HVQFN40 (top view) 3 lines

Table 3. Marking codes

Type number	Marking code
Line A	7 characters used: basic type number:PN7150x where x is the FW variant FW Variants: Version C11001 (not released): x = 1 Version C11002 : x = 1 Version C11006: x = 6
Line B1	6 characters used: diffusion batch sequence number
Line B2 (optional)	6 characters used: assembly ID number
Line C	7 characters used: manufacturing code including: <ul style="list-style-type: none"> • diffusion center code: <ul style="list-style-type: none"> – Z: SSMC – S: Powerchip (PTCT) • assembly center code: <ul style="list-style-type: none"> – S: ATKH • RoHS compliancy indicator: <ul style="list-style-type: none"> – D: Dark Green; fully compliant RoHS and no halogen and antimony • manufacturing year and week, 3 digits: <ul style="list-style-type: none"> – Y: year – WW: week code • product life cycle status code: <ul style="list-style-type: none"> – X: means not qualified product – nothing means released product

9 Marking WLCSP42



Figure 4. PN7150 package marking WLCSP42 (top view)

Table 4. WLCSP package marking (top view)

Line number	Marking code
Line 1	Product identification <ul style="list-style-type: none"> Product name: 7150x; where x is the variant. FW Variant: Version C11002 : x = 2
Line 2	Diffusion batch sequence number <ul style="list-style-type: none"> Diffusion fabrication code: NNNNN Wafer ID: DD
Line 3	Manufacturing code including: <ul style="list-style-type: none"> Diffusion center code: <ul style="list-style-type: none"> Z: SSMC s: Global Foundry S: Power chip (PTCT) Assembly center code: <ul style="list-style-type: none"> Q: ASE-CL RoHS compliancy indicator: <ul style="list-style-type: none"> D: Dark Green; fully compliant RoHS and no halogen and antimony Manufacturing year and week; 4 digits: <ul style="list-style-type: none"> YY: year WW: week code Mask layout version Product life cycle status code: <ul style="list-style-type: none"> X: not qualified product Nothing means released product
Line 4	NXP logo

10 Block diagram

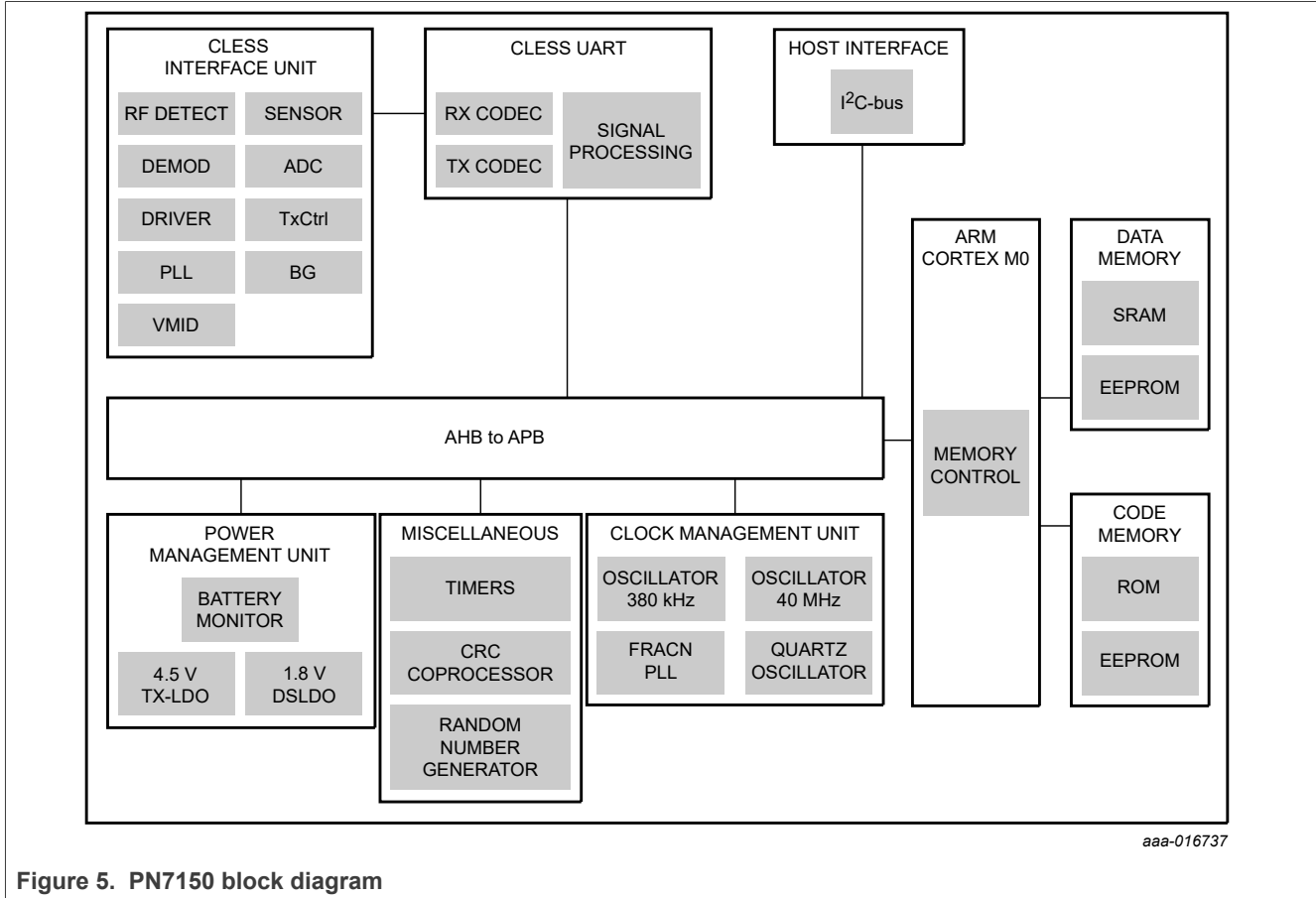

Figure 5. PN7150 block diagram

11 Pinning information

11.1 Pinning HVQFN40

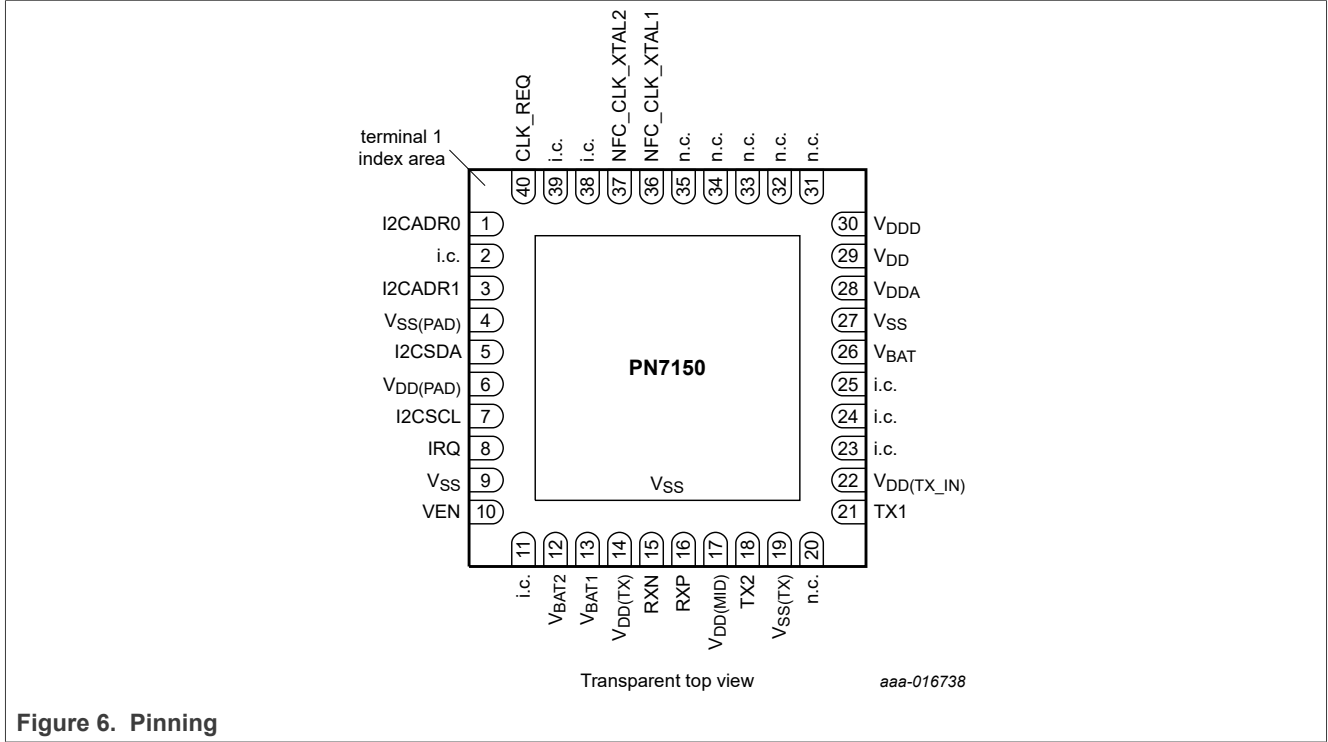

Figure 6. Pinning

Table 5. Pin description

Symbol	Pin	Type ^[1]	Refer	Description
I2CADR0	1	I	V _{DD} (PAD)	I ² C-bus address 0
i.c.	2	-	-	internally connected; must be connected to GND
I2CADR1	3	I	V _{DD} (PAD)	I ² C-bus address 1
V _{SS} (PAD)	4	G	n/a	pad ground
I2CSDA	5	I/O	V _{DD} (PAD)	I ² C-bus data line
V _{DD} (PAD)	6	P	n/a	pad supply voltage
I2CSCL	7	I	V _{DD} (PAD)	I ² C-bus clock line
IRQ	8	O	V _{DD} (PAD)	interrupt request output
V _{SS}	9	G	n/a	ground
VEN	10	I	V _{BAT}	reset pin. Set the device in Hard Power Down
i.c.	11	-	-	internally connected; leave open
V _{BAT2}	12	P	n/a	battery supply voltage; must be connected to V _{BAT}
V _{BAT1}	13	P	n/a	TXLDO input supply voltage
V _{DD} (TX)	14	P	n/a	transmitter supply voltage
RXN	15	I	V _{DD}	negative receiver input

Table 5. Pin description...continued

Symbol	Pin	Type ^[1]	Refer	Description
RXP	16	I	V _{DD}	positive receiver input
V _{DD(MID)}	17	P	n/a	receiver reference input supply voltage
TX2	18	O	V _{DD(TX)}	antenna driver output
V _{SS(TX)}	19	G	n/a	contactless transmitter ground
n.c.	20	-	-	not connected
TX1	21	O	V _{DD(TX)}	antenna driver output
V _{DD(TX_IN)}	22	P	n/a	transmitter input supply voltage; must be connected to V _{DD(TX)}
i.c.	23	-	-	internally connected; leave open
i.c.	24	-	-	internally connected; leave open
i.c.	25	-	-	internally connected; leave open
V _{BAT}	26	P	n/a	battery supply voltage
V _{SS}	27	G	n/a	ground
V _{DDA}	28	P	n/a	analog supply voltage; must be connected to V _{DD}
V _{DD}	29	P	n/a	supply voltage
V _{DDD}	30	P	n/a	digital supply voltage; must be connected to V _{DD}
n.c.	31	-	-	not connected
n.c.	32	-	-	not connected
n.c.	33	-	-	not connected
n.c.	34	-	-	not connected
n.c.	35	-	-	not connected
NFC_CLK_XTAL1	36	I	V _{DD}	oscillator input/PLL input
NFC_CLK_XTAL2	37	O	V _{DD}	oscillator output
i.c.	38	-	-	internally connected; leave open
i.c.	39	-	-	internally connected; leave open
CLK_REQ	40	O	V _{DD(PAD)}	clock request pin

- [1] P = power supply
 G = ground
 I = input
 O = output
 I/O = input/output

11.2 Pinning WLCSP42

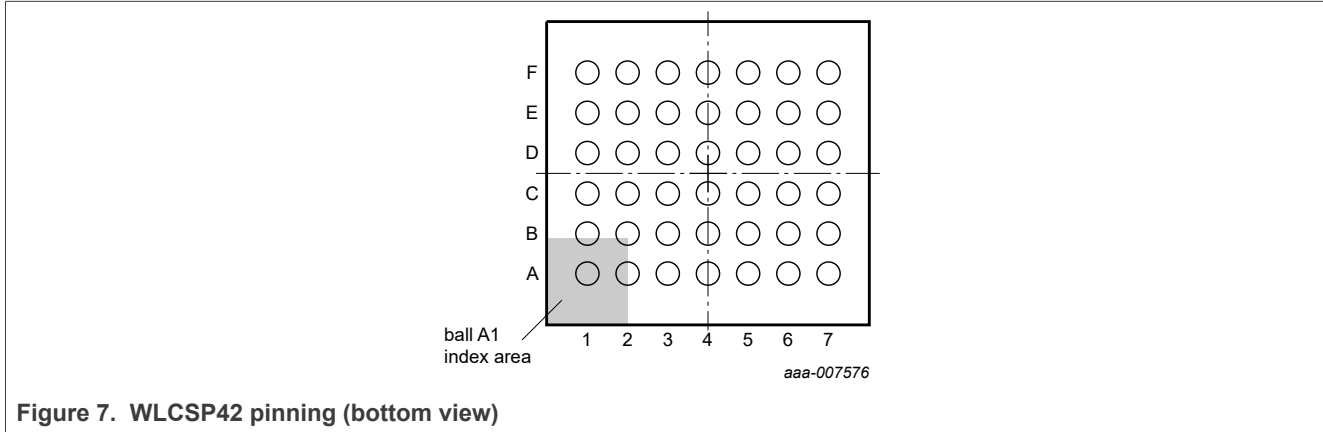

Figure 7. WLCSP42 pinning (bottom view)

Table 6. WLCSP package marking (top view)

Symbol	Pin	Type ^[1]	Refer	Description
V _{BAT2}	A1	P	n/a	battery supply voltage; to be connected to V _{BAT}
i.c.	A2	-	-	internally connected; leave open
V _{BAT1}	A3	P	n/a	TXLDO input supply voltage
RXN	A4	I	V _{DD}	negative receiver input
V _{DD(MID)}	A5	P	n/a	receiver reference input supply voltage
TX2	A6	O	V _{DD(TX)}	antenna driver output
TX1	A7	O	V _{DD(TX)}	antenna driver output
V _{SS}	B1	G	n/a	ground
V _{SS}	B2	G	n/a	ground
V _{DD(TX)}	B3	P	n/a	transmitter supply voltage
RXP	B4	I	V _{DD}	positive receiver input
V _{SS}	B5	G	n/a	ground
V _{SS(TX)}	B6	G	n/a	contactless transmitter ground
V _{DD(TX_IN)}	B7	P	n/a	transmitter input supply voltage; must be connected to V _{DD(TX)}
IRQ	C1	O	V _{DD(PAD)}	interrupt request output
V _{DD(PAD)}	C2	P	n/a	pad supply voltage
VEN	C3	I	V _{BAT}	reset pin. Set the device in Hard Power Down
V _{SS}	C4	G	n/a	power ball. Shall be connected to ground for dissipation
V _{SS}	C5	G	n/a	power ball. Shall be connected to ground for dissipation
i.c.	C6	-	-	internally connected; leave open
i.c.	C7	-	-	internally connected; leave open
I ² C _{SCL}	D1	I	V _{DD(PAD)}	I ² C-bus clock line
I ² C _{SDA}	D2	I/O	V _{DD(PAD)}	I ² C-bus data line

Table 6. WLCSP package marking (top view)...continued

Symbol	Pin	Type ^[1]	Refer	Description
CLK_REQ	D3	O	V _{DD(PAD)}	clock request pin
i.c.	D4	-	-	internally connected; leave open
i.c.	D5	-	-	internally connected; leave open
V _{DDD}	D6	P	n/a	digital supply voltage; must be connected to V _{DD}
V _{BAT}	D7	P	n/a	battery supply voltage
V _{SS(PAD)}	E1	G	n/a	pad ground
I2CADR1	E2	I	V _{DD(PAD)}	I ² C-bus address 1
i.c.	E3	-	-	internally connected; leave open
NFC_CLK_XTAL1	E4	I	V _{DD}	oscillator input/PLL input
i.c.	E5	-	-	internally connected; leave open
i.c.	E6	-	-	internally connected; leave open
V _{DD}	E7	P	n/a	LDO output supply voltage
I2CADR0	F1	I	V _{DD(PAD)}	I ² C-bus address 0
i.c.	F2	-	-	internally connected; must be connected to GND
NFC_CLK_XTAL2	F3	O	V _{DD}	oscillator output
i.c.	F4	-	-	internally connected; leave open
i.c.	F5	-	-	internally connected; must be connected to GND
i.c.	F6	-	-	internally connected; leave open
i.c.	F7	-	-	internally connected; leave open

- [1] P = power supply
 G = ground
 I = input
 O = output
 I/O = input/output

12 Functional description

PN7150 can be connected on a host controller through I²C-bus. The logical interface towards the host baseband is NCI-compliant [2] with additional command set for NXP-specific product features. This IC is fully user controllable by the firmware interface described in [5].

Moreover, PN7150 provides flexible and integrated power management unit in order to preserve energy supporting Power Off mode.

In the following chapters you will find also more details about PN7150 with references to very useful application note such as:

- PN7150 User Manual ([5]):
User Manual describes the software interfaces (API) based on the NFC forum NCI standard. It does give full description of all the NXP NCI extensions coming in addition to NCI standard ([2]).
- PN7150 Hardware Design Guide ([6]):
Hardware Design Guide provides an overview on the different hardware design options offered by the IC and provides guidelines on how to select the most appropriate ones for a given implementation. In particular, this document highlights the different chip power states and how to operate them in order to minimize the average NFC-related power consumption so to enhance the battery lifetime.
- PN7150 Antenna and Tuning Design Guide ([7]):
Antenna and Tuning Design Guide provides some guidelines regarding the way to design an NFC antenna for the PN7150 chip.
It also explains how to determine the tuning/matching network to place between this antenna and the PN7150. Standalone antenna performances evaluation and final RF system validation (PN7150 + tuning/matching network + NFC antenna within its final environment) are also covered by this document.
- PN7150 Low-Power Mode Configuration ([10]):
Low-Power Mode Configuration documentation provides guidance on how PN7150 can be configured in order to reduce current consumption by using Low-power polling mode.

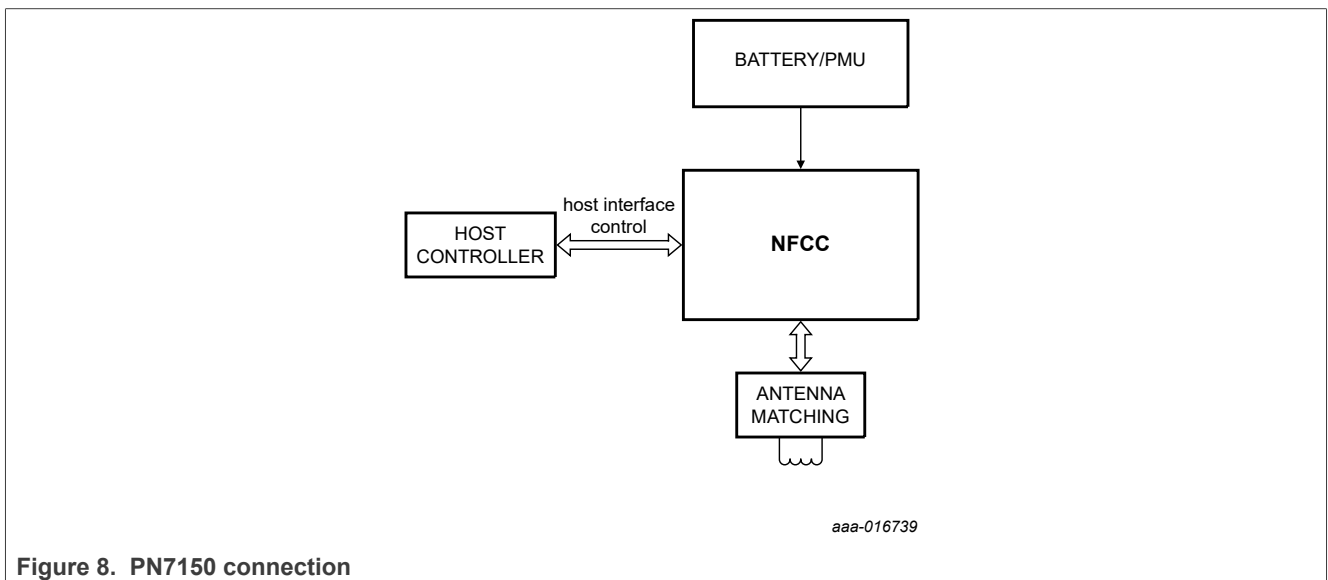

Figure 8. PN7150 connection

Note: To avoid data corruption inside the EEPROM memory, make sure to follow these rules:

- Prevent re-applying RF settings configuration when not required (different possibilities of implementation exist depending on the integration environment, please contact NXP support for more details).
- Insure RF settings configuration is not interrupted (no interruption between related CORE_SET_CONFIG_CMD and CORE_SET_CONFIG_RSP).
- Split the RF settings configuration into several CORE_SET_CONFIG_CMD to limit the time for the FW to treat this command. Only one transferred RF parameter via the CORE_SET_CONFIG_CMD takes approximately 2.7ms. 5.4ms in the specific case where the RF parameter resides in two separated Flash memory blocks, which increase the probability for an interruption between CORE_SET_CONFIG_CMD and CORE_SET_CONFIG_RSP.
- It must be ensured that the RF settings configuration will not be interrupted due to a power off or hardware reset. Once the memory is corrupted, the IC cannot recover from this stage and cannot be used anymore.

12.1 System modes

12.1.1 System power modes

PN7150 is designed to enable the different power modes from the system.

Two power modes are specified: Full power mode and Power Off mode.

Table 7. System power mode description

System power mode	Description
Full power mode	the main supply (V_{BAT}) as well as the host interface supply ($V_{DD(PAD)}$) is available, all use cases can be executed
Power Off mode	the system is kept Hard Power Down (HPD)

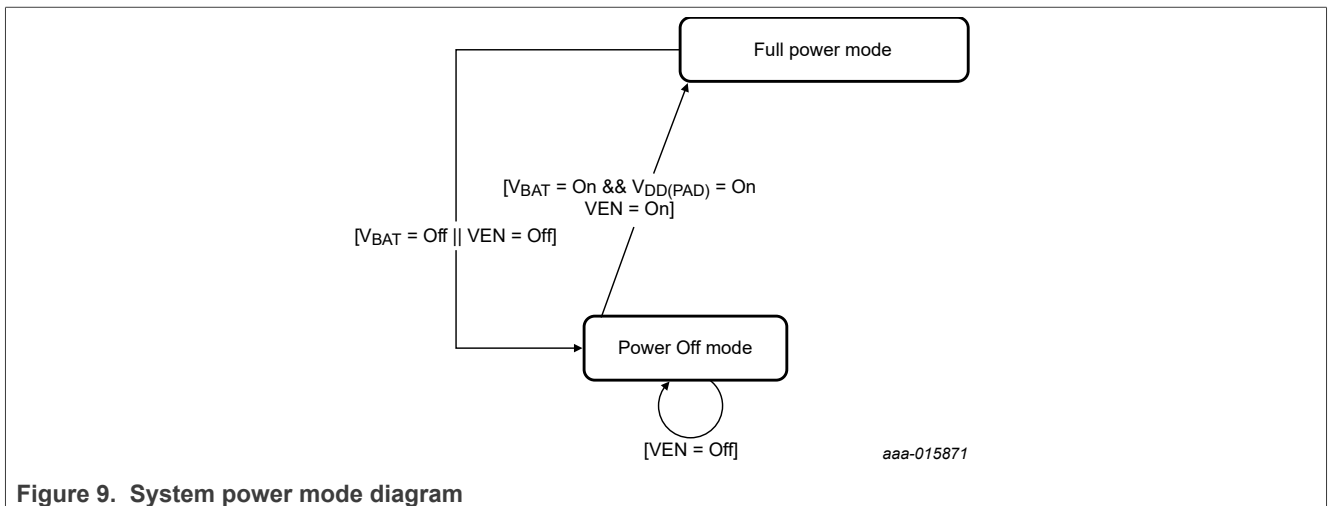

Figure 9. System power mode diagram

[Table 8](#) summarizes the system power mode of the PN7150 depending on the status of the external supplies available in the system:

Table 8. System power modes configuration

V _{BAT}	VEN	Power mode
Off	X	Power Off mode
On	Off	Power Off mode
On	On	Full power mode

Depending on power modes, some application states are limited:

Table 9. System power mode descriptions

System power mode	Allowed communication modes
Power Off mode	no communication mode available
Full power mode	Reader/Writer, Card Emulation, P2P modes

12.1.2 PN7150 power states

Next to system power modes defined by the status of the power supplies, the power states include the logical status of the system thus extend the power modes.

4 power states are specified: Monitor, Hard Power Down (HPD), Standby, Active.

Table 10. PN7150 power states

Power state name	Description
Monitor	The PN7150 is supplied by V_{BAT} which voltage is below its programmable critical level, VEN voltage > 1.1 V and the Monitor state is enabled. The system power mode is Power Off mode.
Hard Power Down	The PN7150 is supplied by V_{BAT} which voltage is above its programmable critical level when Monitor state is enabled and PN7150 is kept in Hard Power Down (VEN voltage is kept low by host or SW programming) to have the minimum power consumption. The system power mode is in Power Off.
Standby	The PN7150 is supplied by V_{BAT} which voltage is above its programmable critical level when the Monitor state is enabled, VEN voltage is high (by host or SW programming) and minimum part of PN7150 is kept supplied to enable configured wake-up sources which allow to switch to Active state; RF field, Host interface. The system power mode is Full power mode.
Active	The PN7150 is supplied by V_{BAT} which voltage is above its programmable critical level when Monitor state is enabled, VEN voltage is high (by host or SW programming) and the PN7150 internal blocks are supplied. 3 functional modes are defined: Idle, Target and Initiator. The system power mode is Full power mode.

At application level, the PN7150 will continuously switch between different states to optimize the current consumption (polling loop mode). Refer to Table 1 for targeted current consumption in here described states.

The PN7150 is designed to allow the host controller to have full control over its functional states, thus of the power consumption of the PN7150 based NFC solution and possibility to restrict parts of the PN7150 functionality.

12.1.2.1 Monitor state

In Monitor state, the PN7150 will exit it only if the battery voltage recovers over the critical level. Battery voltage monitor thresholds show hysteresis behavior as defined in Table 27.

12.1.2.2 Hard Power Down (HPD) state

The Hard Power Down state is entered when $V_{DD(PAD)}$ and V_{BAT} are high by setting VEN voltage < 0.4 V. As these signals are under host control, the PN7150 has no influence on entering or exiting this state.

12.1.2.3 Standby state

Active state is PN7150’s default state after boot sequence in order to allow a quick configuration of PN7150. It is recommended to change the default state to Standby state after first boot in order to save power. PN7150 can switch to Standby state autonomously (if configured by host).

In this state, PN7150 most blocks including CPU are no more supplied. Number of wake-up sources exist to put PN7150 into Active state:

- I²C-bus interface wake-up event
- Antenna RF level detector
- Internal timer event when using polling loop (380 kHz Low-power oscillator is enabled)

If wake-up event occurs, PN7150 will switch to Active state. Any further operation depends on software configuration and/or wake-up source.

12.1.2.4 Active state

Within the Active state, the system is acting as an NFC device. The device can be in 3 different functional modes: Idle, Poller and Target.

Table 11. Functional modes in active state

Functional modes	Description
Idle	the PN7150 is active and allows host interface communication. The RF interface is not activated.
Listener	the PN7150 is active and is configured for listening to external device.
Poller	the PN7150 is active and is configured in Poller mode. It polls external device

Poller mode

In this mode, PN7150 is acting as Reader/Writer or NFC Initiator, searching for or communicating with passive tags or NFC target. Once RF communication has ended, PN7150 will switch to active battery mode (that is, switch off RF transmitter) to save energy. Poller mode shall be used with $2.7\text{ V} < V_{BAT} < 5.5\text{ V}$ and VEN voltage $> 1.1\text{ V}$. Poller mode shall not be used with $V_{BAT} < 2.7\text{ V}$. $V_{DD(PAD)}$ is within its operational range (see Table 1).

Listener mode

In this mode, PN7150 is acting as a card or as an NFC Target. Listener mode shall be used with $2.3\text{ V} < V_{BAT} < 5.5\text{ V}$ and VEN voltage $> 1.1\text{ V}$.

12.1.2.5 Polling loop

The polling loop will sequentially set PN7150 in different power states (Active or Standby). All RF technologies supported by PN7150 can be independently enabled within this polling loop.

There are 2 main phases in the polling loop:

- Listening phase. The PN7150 can be in Standby power state or Listener mode
- Polling phase. The PN7150 is in Poller mode

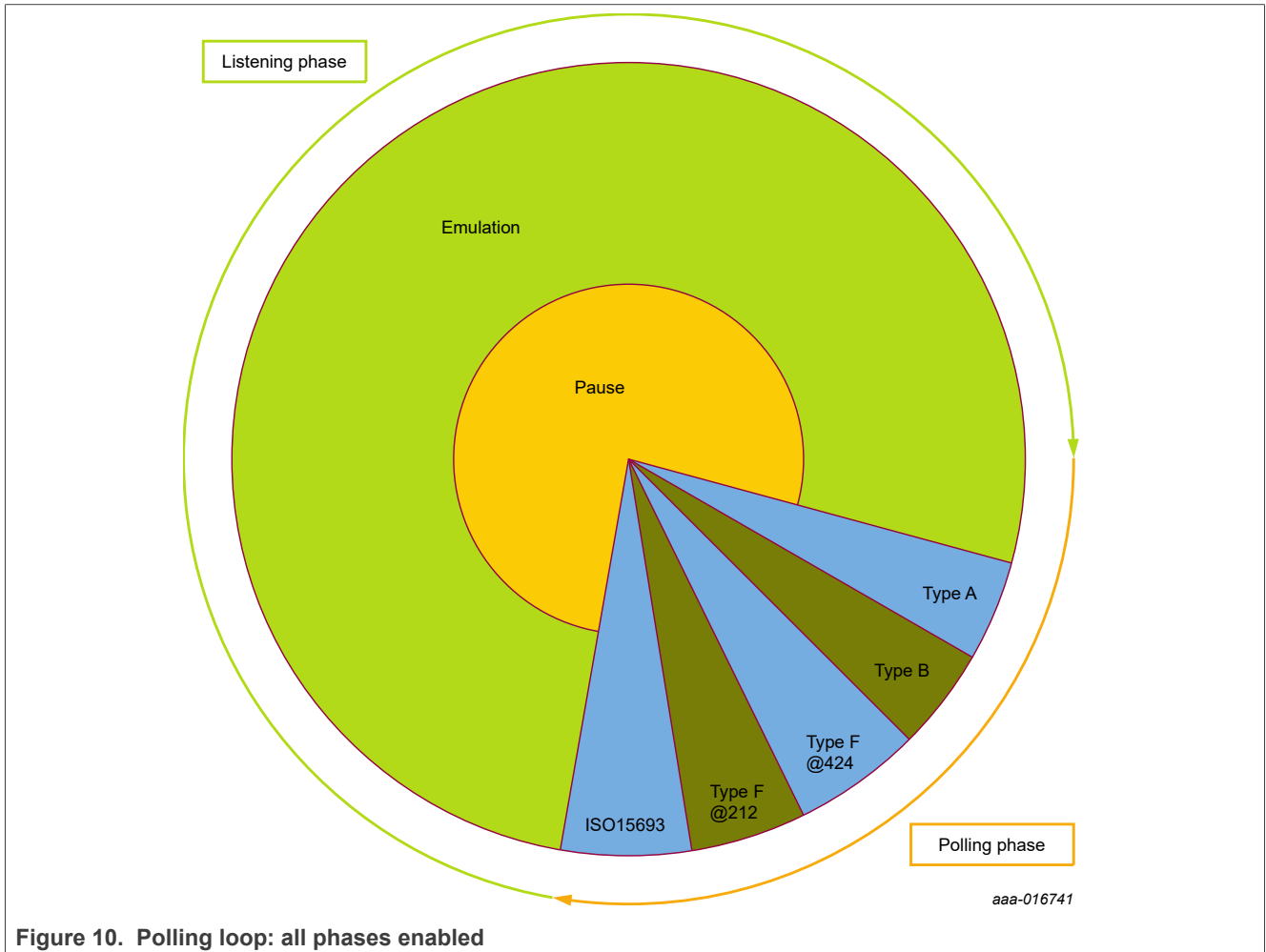

Figure 10. Polling loop: all phases enabled

Listening phase uses Standby power state (when no RF field) and PN7150 goes to Listener mode when RF field is detected. When in Polling phase, PN7150 goes to Poller mode.

To further decrease the power consumption when running the polling loop, PN7150 features a low-power RF polling. When PN7150 is in Polling phase instead of sending regularly RF command, PN7150 senses with a short RF field duration if there is any NFC Target or card/tag present. If yes, then it goes back to standard polling loop. With 500 ms (configurable duration, see [5]) listening phase duration, the average power consumption is around 150 µA.

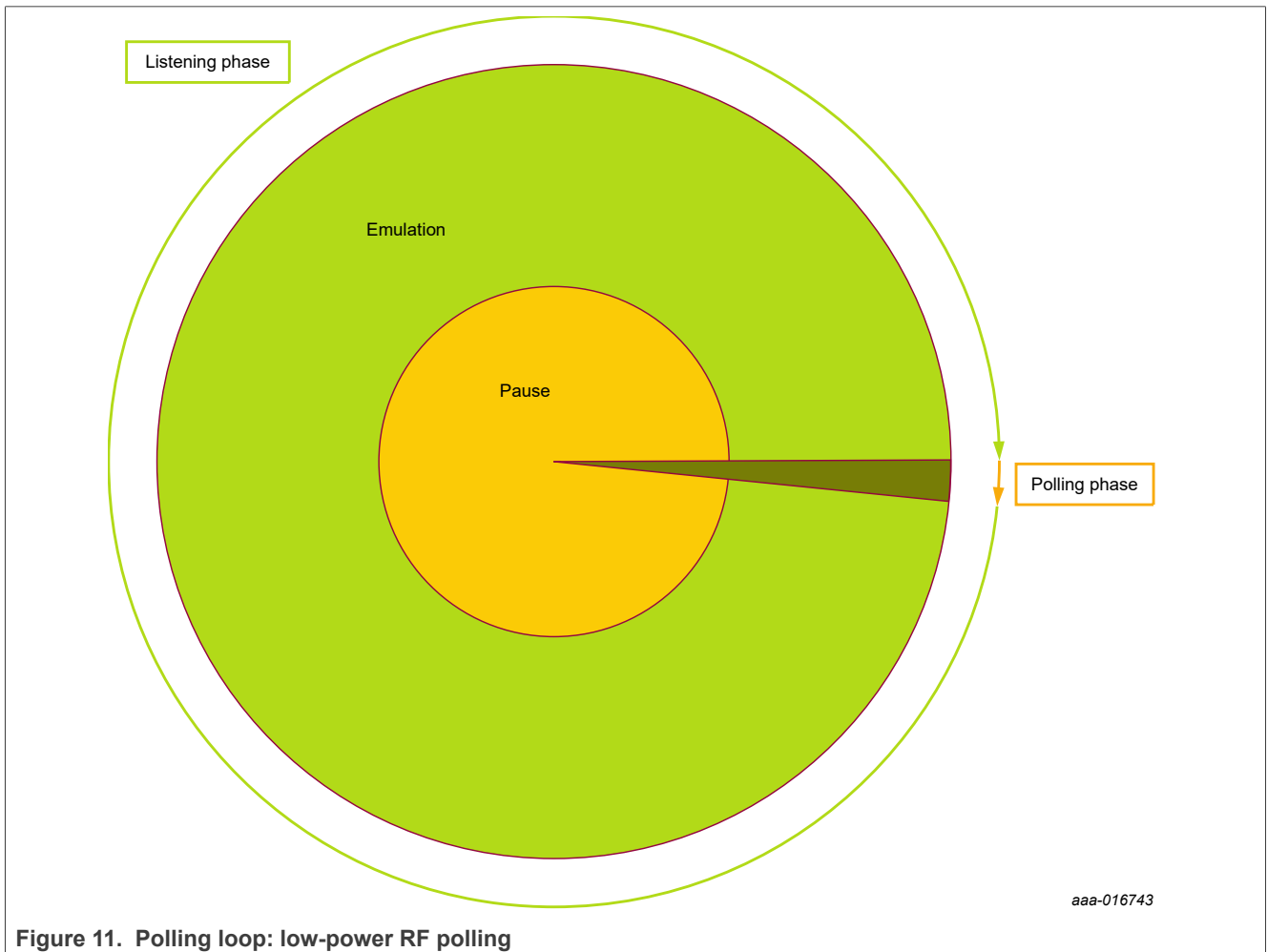

Figure 11. Polling loop: low-power RF polling

The detailed description of polling loop configuration options is given in [5].

12.2 Microcontroller

PN7150 is controlled via an embedded ARM Cortex-M0 microcontroller core.

PN7150 features integrated in firmware are referenced in [5].

12.3 Host interface

PN7150 provides the support of an I²C-bus Slave Interface, up to 3.4 MBaud.

The host interface is waken-up on I²C-bus address.

To enable and ensure data flow control between PN7150 and host controller, additionally a dedicated interrupt line IRQ is provided which Active state is programmable. See [5] for more information.

12.3.1 I²C-bus interface

The I²C-bus interface implements a slave I²C-bus interface with integrated shift register, shift timing generation and slave address recognition.

I²C-bus Standard mode (100 kHz SCL), Fast mode (400 kHz SCL) and High-speed mode (3.4 MHz SCL) are supported.

The mains hardware characteristics of the I²C-bus module are:

- Support slave I²C-bus
- Standard, Fast and High-speed modes supported
- Wake-up of PN7150 on its address only
- Serial clock synchronization can be used by PN7150 as a handshake mechanism to suspend and resume serial transfer (clock stretching)

The I²C-bus interface module meets the I²C-bus specification [4] except General call, 10-bit addressing and Fast mode Plus (Fm+).

12.3.1.1 I²C-bus configuration

The I²C-bus interface shares four pins with I²C-bus interface also supported by PN7150. When I²C-bus is configured in EEPROM settings, functionality of interface pins changes to one described in Table 10.

Table 12. Functionality for I²C-bus interface

Pin name	Functionality
I2CADR0	I ² C-bus address 0
I2CADR1	I ² C-bus address 1
I2CSCL ^[1]	I ² C-bus clock line
I2CSDA ^[1]	I ² C-bus data line

[1] I2CSCL and I2CSDA are not fail-safe and V_{DD(pad)} shall always be available when using the SCL and SDA lines connected to these pins.

PN7150 supports 7-bit addressing mode. Selection of the I²C-bus address is done by 2-pin configurations on top of a fixed binary header: 0, 1, 0, 1, 0, I2CADR1, I2CADR0, R/W.

Table 13. I²C-bus interface addressing

I2CADR1	I2CADR0	I ² C-bus address (R/W = 0, write)	I ² C-bus address (R/W = 1, read)
0	0	0x50	0x51
0	1	0x52	0x53
1	0	0x54	0x55
1	1	0x56	0x57

12.4 PN7150 clock concept

There are 4 different clock sources in PN7150:

- 27.12 MHz clock coming either/or from:
 - Internal oscillator for 27.12 MHz crystal connection
 - Integrated PLL unit which includes a 1 GHz VCO, taking its reference clock on pin NFC_CLK_XTAL1
- 13.56 MHz RF clock recovered from RF field
- Low-power oscillator 40 MHz
- Low-power oscillator 380 kHz

12.4.1 27.12 MHz quartz oscillator

When enabled, the 27.12 MHz quartz oscillator applied to PN7150 is the time reference for the RF front end when PN7150 is behaving in Reader mode or NFCIP-1 initiator.

Therefore stability of the clock frequency is an important factor for reliable operation. It is recommended to adopt the circuit shown in [Figure 12](#).

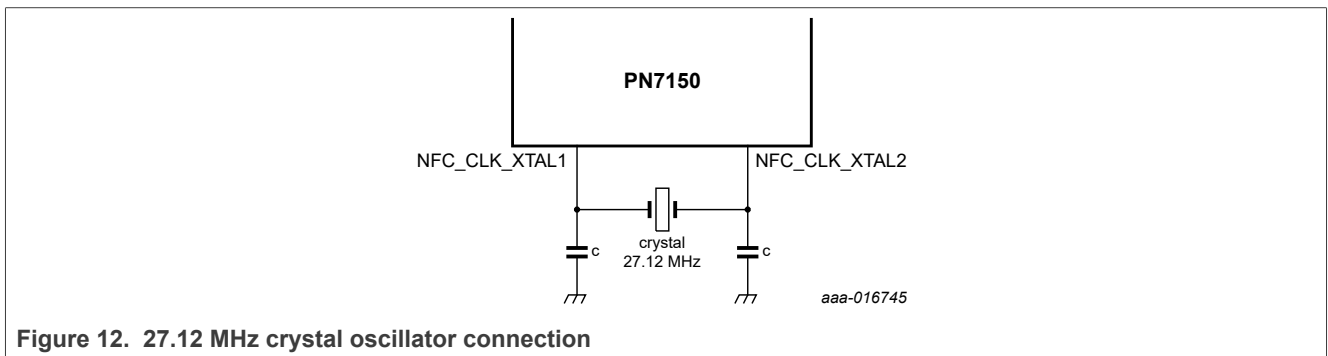

Figure 12. 27.12 MHz crystal oscillator connection

[Table 14](#) describes the levels of accuracy and stability required on the crystal.

Table 14. Crystal requirements

Symbol	Parameter	Conditions	Min	Typ	Max	Unit
f_{xtal}	crystal frequency	ISO/IEC and FCC compliancy	-	27.12	-	MHz
Δf_{xtal}	crystal frequency accuracy	full operating range	[1] -100	-	+100	ppm
		all V_{BAT} range; $T = 20\text{ }^{\circ}\text{C}$	[1] -50	-	+50	ppm
		all temperature range; $V_{BAT} = 3.6\text{ V}$	[1] -50	-	+50	ppm
ESR	equivalent series resistance		-	50	100	Ω
C_L	load capacitance		-	10	-	pF
P_{xtal}	crystal power dissipation		-	-	100	μW

[1] This requirement is according to FCC regulations requirements. To meet only ISO/IEC 14443 and ISO/IEC 18092, then $\pm 14\text{ kHz}$ apply.

12.4.2 Integrated PLL to make use of external clock

When enabled, the PLL is designed to generate a low noise 27.12 MHz for an input clock 13 MHz, 19.2 MHz, 24 MHz, 26 MHz, 38.4 MHz and 52 MHz.

The 27.12 MHz of the PLL is used as the time reference for the RF front end when PN7150 is behaving in Reader mode or ISO/IEC 18092 Initiator as well as in Target when configured in Active Communication mode.

The input clock on NFC_CLK_XTAL1 shall comply with the following phase noise requirements for the following input frequency: 13 MHz, 19.2 MHz, 24 MHz, 26 MHz, 38.4 MHz and 52 MHz:

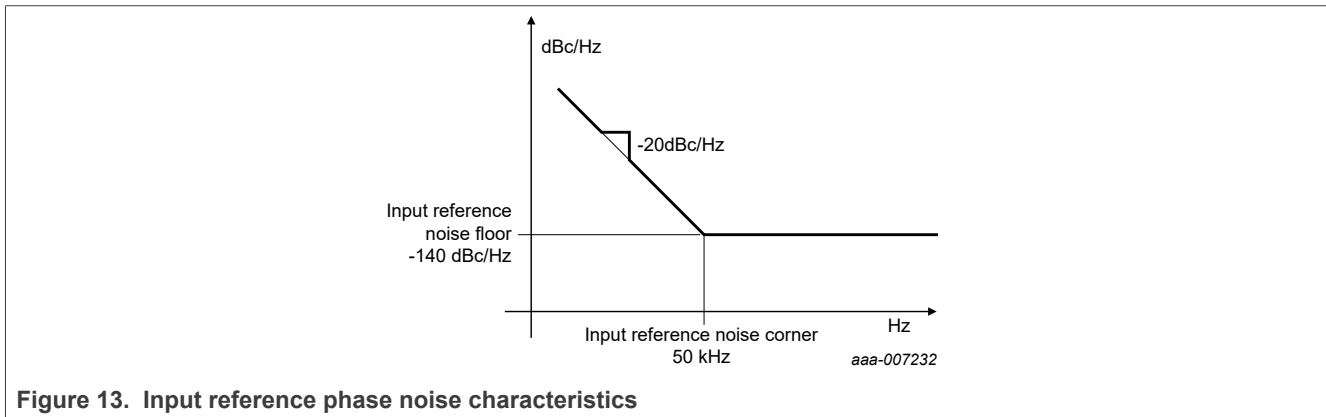

Figure 13. Input reference phase noise characteristics

This phase noise is equivalent to an RMS jitter of 6.23 ps from 10 Hz to 1 MHz. For configuration of input frequency, refer to [9]. These six pre-programmed and validated frequencies for the PLL are: 13 MHz, 19.2 MHz, 24 MHz, 26 MHz, 38.4 MHz and 52 MHz.

Table 15. PLL input requirements

Coupling: single-ended, AC coupling;

Symbol	Parameter	Conditions	Min	Typ	Max	Unit
f _{clk}	clock frequency	ISO/IEC and FCC compliance	-	13	-	MHz
			-	19.2	-	MHz
			-	24	-	MHz
			-	26	-	MHz
			-	38.4	-	MHz
			-	52	-	MHz
f _{i(ref)acc}	reference input frequency accuracy	full operating range; frequencies typical values: 13 MHz, 26 MHz and 52 MHz	[1] -25	-	+25	ppm
		full operating range; frequencies typical values: 19.2 MHz, 24 MHz and 38.4 MHz	[1] -50	-	+50	ppm
φ _n	phase noise	input noise floor at 50 kHz	-140	-	-	dB/Hz
Sinusoidal shape						
V _{i(p-p)}	peak-to-peak input voltage		0.2	-	1.8	V

Table 15. PLL input requirements...continued

Coupling: single-ended, AC coupling;

Symbol	Parameter	Conditions	Min	Typ	Max	Unit
$V_{i(\text{clk})}$	clock input voltage		0	-	1.8	V
Square shape						
$V_{i(\text{clk})}$	clock input voltage		0	-	$1.8 \pm 10\%$	V

[1] This requirement is according to FCC regulations requirements. To meet only ISO/IEC 14443 and ISO/IEC 18092, then ± 400 ppm limits apply.

For detailed description of clock request mechanisms, refer to [5] and [6].

12.4.3 Low-power 40 MHz $\pm 2.5\%$ oscillator

Low-power OSC generates a 40 MHz internal clock. This frequency is divided by two to make the system clock.

12.4.4 Low-power 380 kHz oscillator

A Low Frequency Oscillator (LFO) is implemented to drive a counter (WUC) waking-up PN7150 from Standby state. This allows implementation of low-power reader polling loop at application level. Moreover, this 380 kHz is used as the reference clock for write access to EEPROM memory.

12.5 Power concept

12.5.1 PMU functional description

The Power Management Unit of PN7150 generates internal supplies required by PN7150 out of V_{BAT} input supply voltage:

- V_{DD} : internal supply voltage
- $V_{DD(TX)}$: output supply voltage for the RF transmitter

Figure 14 shows the main blocks available in the PMU.

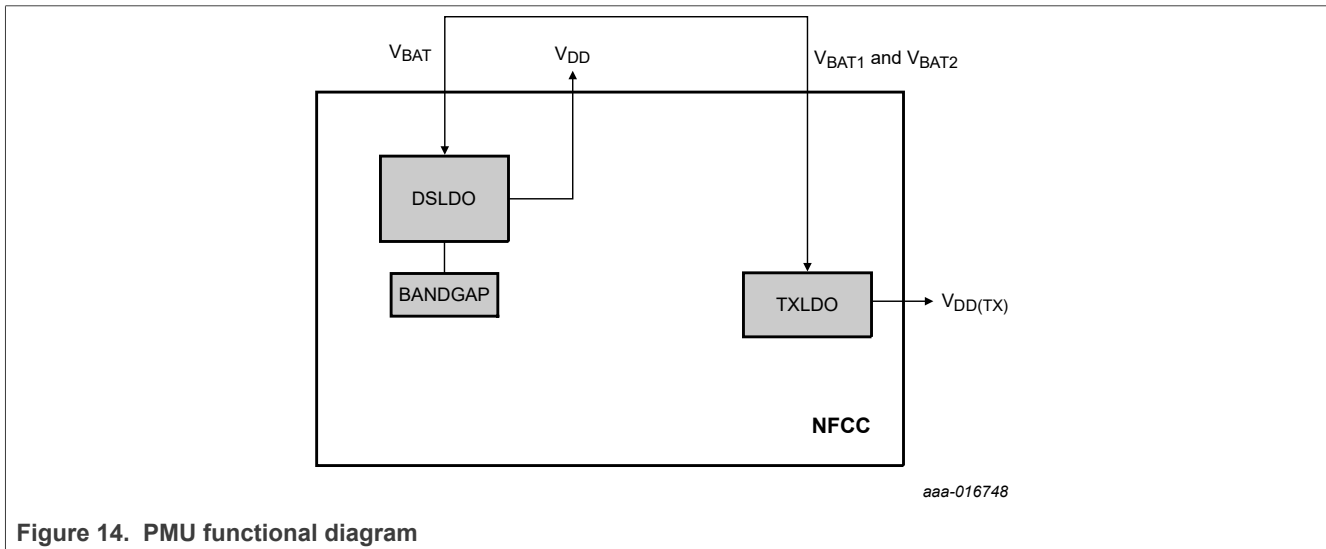

Figure 14. PMU functional diagram

12.5.2 DSLDO: dual supply LDO

The input pin of the DSLDO is V_{BAT} .

The Low drop-out regulator provides V_{DD} required in PN7150.

12.5.3 TXLDO

Transmitter voltage can be generated by internal LDO ($V_{DD(TX)}$) or come from an external supply source $V_{DD(TX)}$.

The regulator has been designed to work in two configurations:

12.5.3.1 Configuration 1: supply connection in case the battery is used to generate RF field

The Low drop Out Regulator has been designed to generate a 3.0 V, 3.3 V or 3.6 V supply voltage to a transmitter with a current load up to 180 mA.

The output is called $V_{DD(TX)}$. The input supply voltage of this regulator is a battery voltage connected to V_{BAT1} pin.

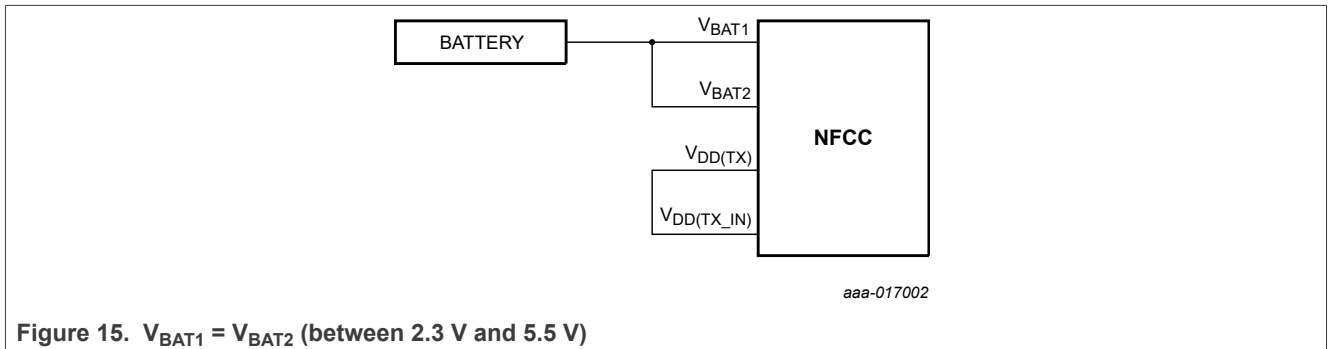

Figure 15. $V_{BAT1} = V_{BAT2}$ (between 2.3 V and 5.5 V)

$V_{DD(TX)}$ value shall be chosen according to the minimum targeted V_{BAT} value for which reader mode shall work.

- If V_{BAT} is above 3.0 V plus the regulator voltage dropout, then $V_{DD(TX)} = 3.0$ V shall be chosen:

$$V_{BAT} \geq (3.0V + 1\Omega \times \text{load}) \Rightarrow V_{DD(TX)} = 3.0V$$

$$3.0V \geq V_{BAT} \geq 2.3V \Rightarrow V_{DD(TX)} = V_{BAT} - 1\Omega \times \text{load}$$

- If V_{BAT} is above 3.3 V plus the regulator voltage dropout, then $V_{DD(TX)} = 3.3$ V shall be chosen:

$$V_{BAT} \geq (3.3V + 1\Omega \times \text{load}) \Rightarrow V_{DD(TX)} = 3.3V$$

$$3.3V \geq V_{BAT} \geq 2.3V \Rightarrow V_{DD(TX)} = V_{BAT} - 1\Omega \times \text{load}$$

- If V_{BAT} is above 3.6 V plus the regulator voltage dropout, then $V_{DD(TX)} = 3.6$ V shall be chosen:

$$V_{BAT} \geq (3.6V + 1\Omega \times \text{load}) \Rightarrow V_{DD(TX)} = 3.6V$$

$$3.6V \geq V_{BAT} \geq 2.3V \Rightarrow V_{DD(TX)} = V_{BAT} - 1\Omega \times \text{load}$$

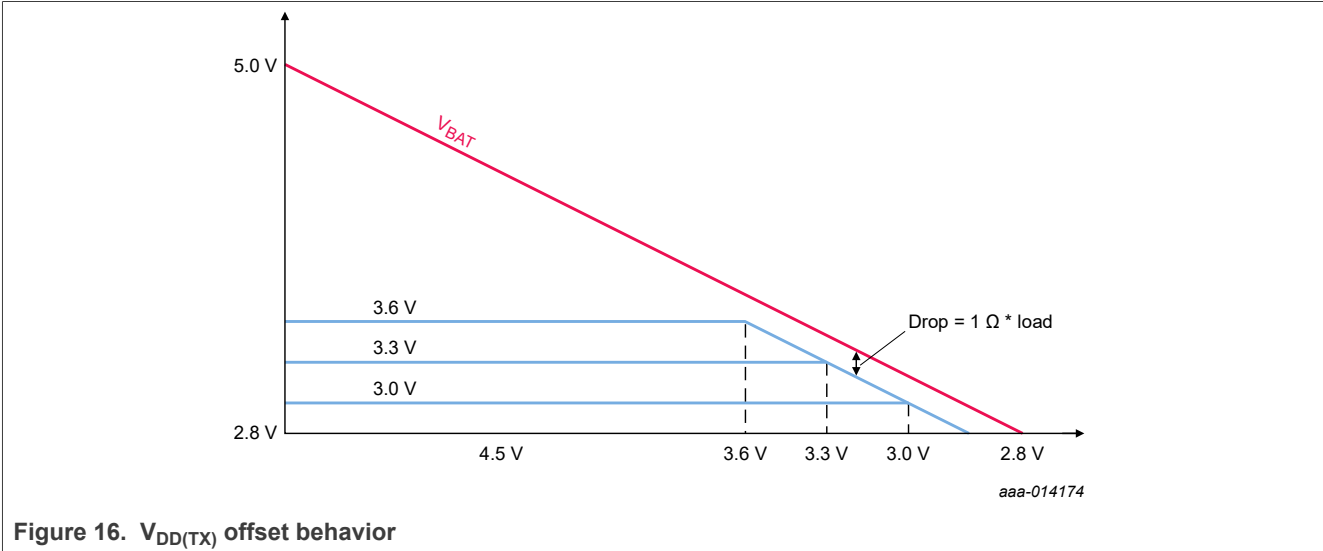

Figure 16 shows $V_{DD(TX)}$ offset disabled behavior for both cases of $V_{DD(TX)}$ programmed for 3.0 V, 3.3 V or 3.6 V.

In Standby state, whenever $V_{DD(TX)}$ is configured for 3.0 V, 3.3 V or 3.6 V, $V_{DD(TX)}$ is regulated at 2.5 V.

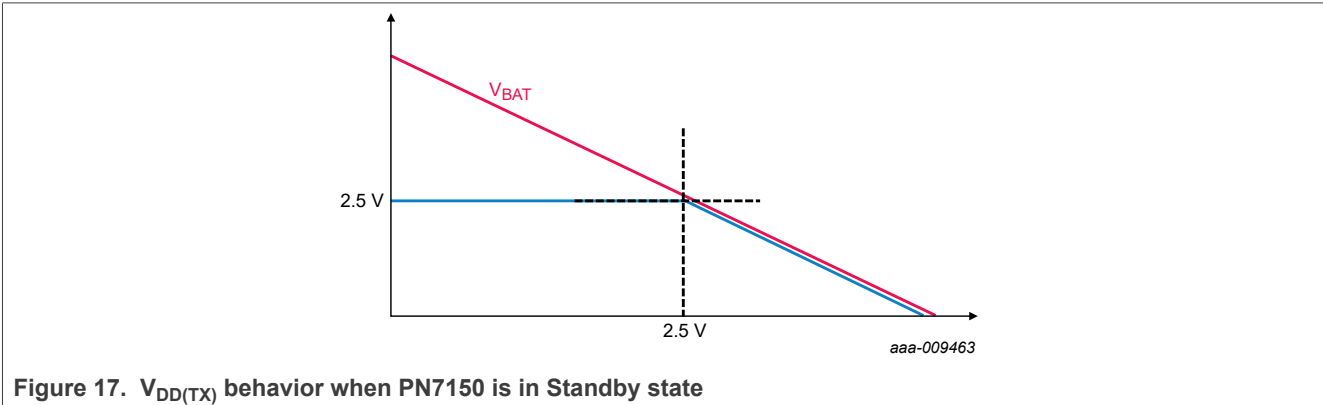

Figure 17 shows the case where the PN7150 is in standby state.

12.5.3.2 Configuration 2: supply connection in case a 5 V supply is used to generate RF field with the use of TXLDO

TXLDO has also the possibility to generate 4.75 V or 4.5 V supply in case the supply of this regulator is an external 5 V supply.

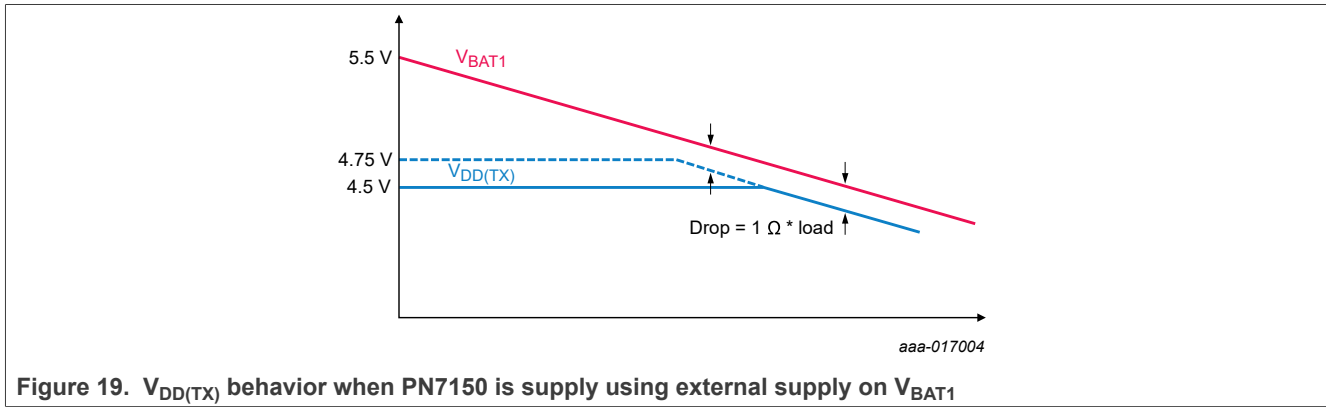
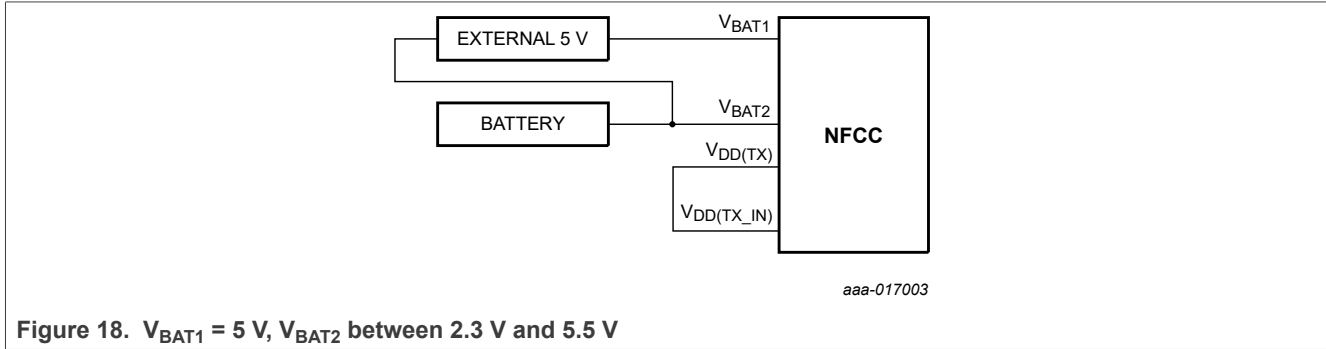

Figure 19 shows the behavior of $V_{DD(TX)}$ depending on V_{BAT1} value.

12.5.3.3 TXLDO limiter

The TXLDO includes a current limiter to avoid too high current within TX1, TX2 when in reader or initiator modes.

The current limiter block compares an image of the TXLDO output current to a reference. Once the reference is reached, the output current gets limited which is equivalent to a typical output current of 220 mA whatever V_{BAT} or V_{BAT1} value in the range of 2.3 V to 5.5 V.

12.5.4 Battery voltage monitor

The PN7150 features low-power V_{BAT} voltage monitor which protects mobile device battery from being discharged below critical levels. When V_{BAT} voltage goes below $V_{BATcritical}$ threshold, then the PN7150 goes in Monitor state. Refer to [Figure 20](#) for the principle schematic of the battery monitor.

The battery voltage monitor is enabled via an EEPROM setting.

At the first start-up, V_{BAT} voltage monitor functionality is OFF and then enabled if properly configured in EEPROM. The PN7150 monitors battery voltage continuously.

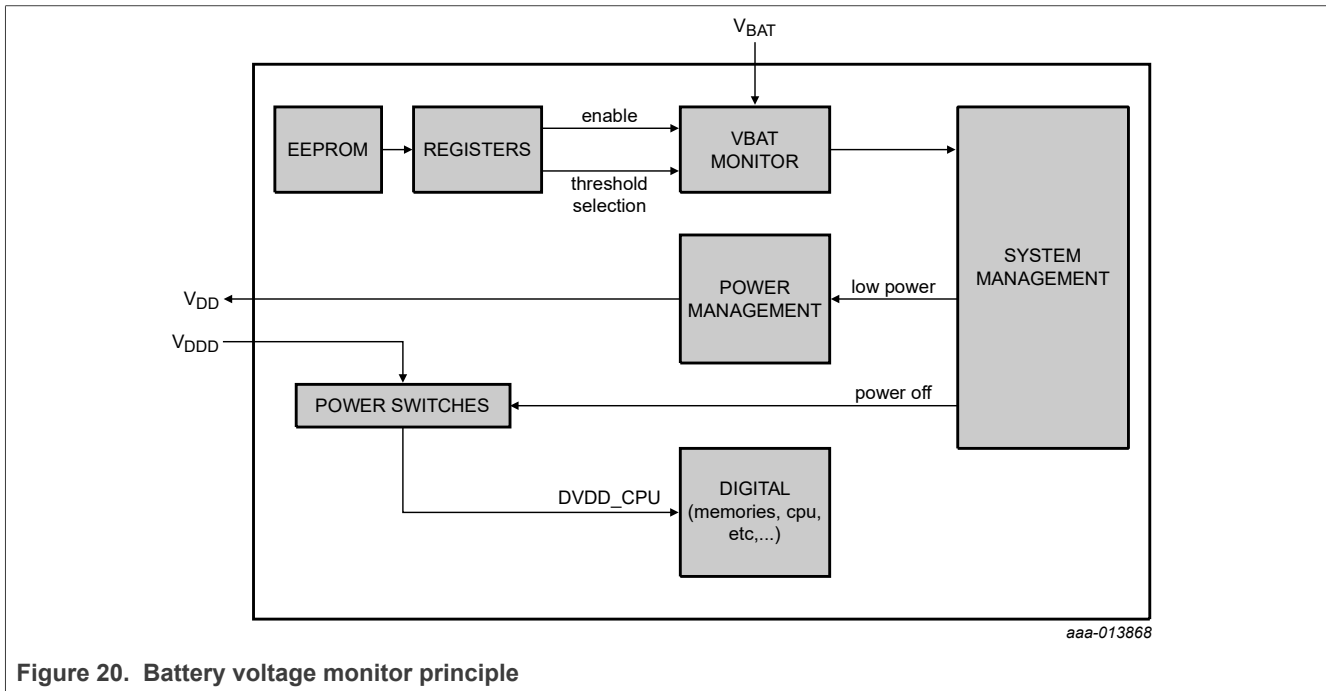

Figure 20. Battery voltage monitor principle

The value of the critical level can be configured to 2.3 V or 2.75 V by an EEPROM setting. This value has a typical hysteresis around 150 mV.

12.6 Reset concept

12.6.1 Resetting PN7150

To enter reset, there are 2 ways:

- Pulling VEN voltage low (Hard Power Down state)
- if V_{BAT} monitor is enabled: lowering V_{BAT} below the monitor threshold (Monitor state, if VEN voltage is kept above 1.1 V)

Reset means resetting the embedded FW execution and the registers values to their default values. Part of these default values is defined from EEPROM data loaded values, others are hardware defined. See [5] to know which ones are accessible to tune PN7150 to the application environment.

To get out of reset:

- Pulling VEN voltage high with V_{BAT} above V_{BAT} monitor threshold if enabled

Figure 21 shows the reset via VEN pin.

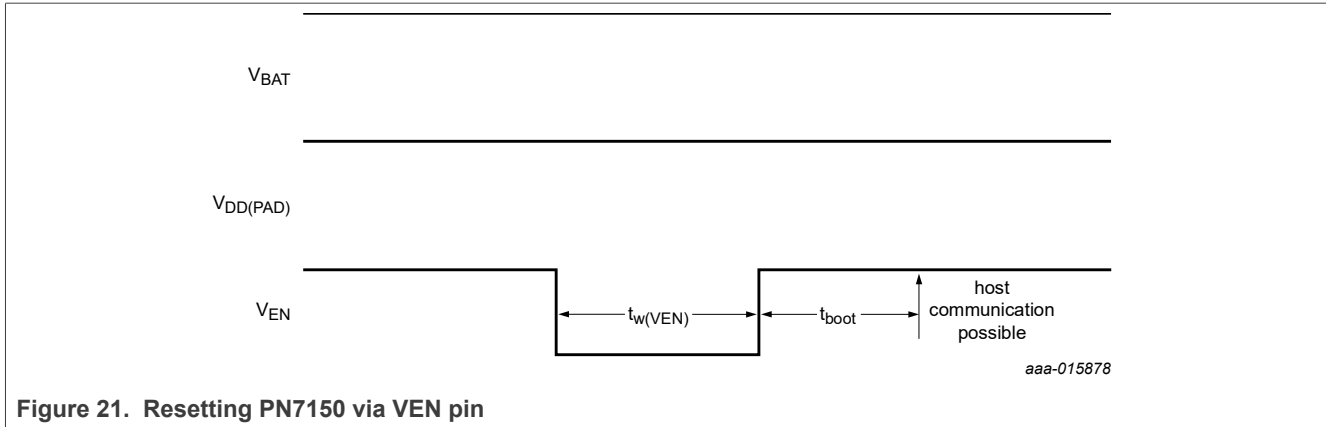

Figure 21. Resetting PN7150 via VEN pin

See Section 16.2.2 for the timings values.

12.6.2 Power-up sequences

PN7150 has two power supplies. PN7150 allows these supplies to be set up independently, therefore different power-up sequences have to be considered.

12.6.2.1 V_{BAT} is set up before $V_{DD(PAD)}$

This is at least the case when V_{BAT} pin is directly connected to the battery and when PN7150 V_{BAT} is always supplied as soon the system is supplied.

As VEN pin is referred to V_{BAT} pin, VEN voltage shall go high after V_{BAT} has been set.

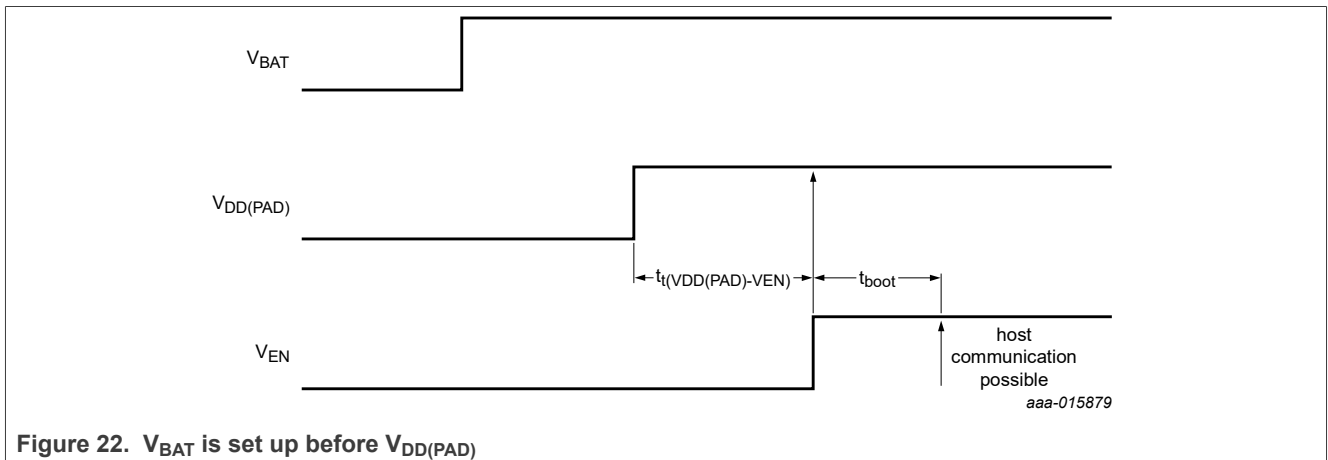

See Section 16.2.3 for the timings values.

12.6.2.2 $V_{DD(PAD)}$ and V_{BAT} are set up in the same time

It is at least the case when V_{BAT} pin is connected to a PMU/regulator which also supply $V_{DD(PAD)}$.

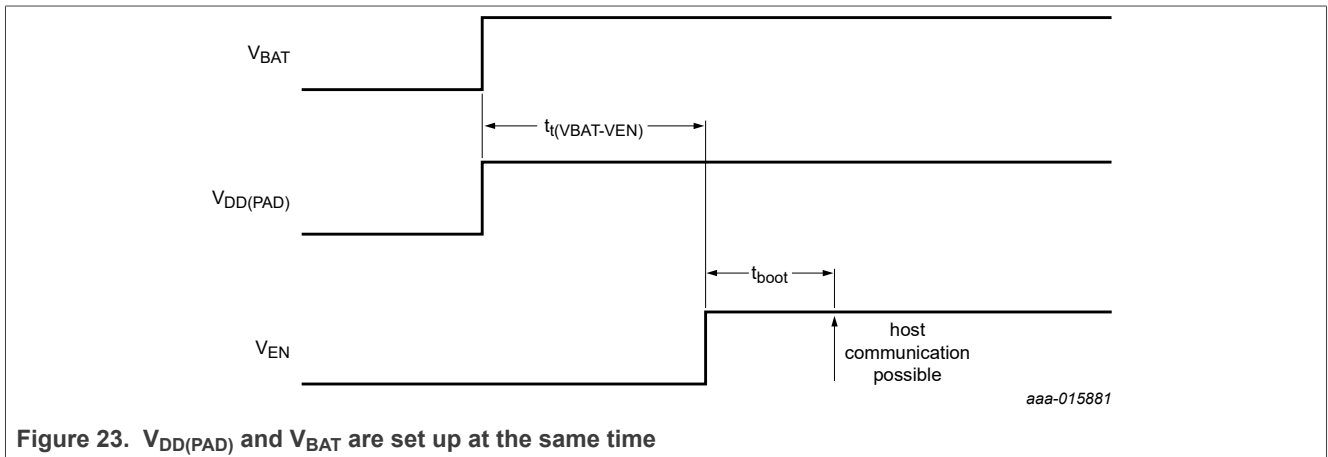

See Section 16.2.3 for the timings values.

12.6.2.3 PN7150 has been enabled before $V_{DD(PAD)}$ is set up or before $V_{DD(PAD)}$ has been cut off

This can be the case when V_{BAT} pin is directly connected to the battery and when $V_{DD(PAD)}$ is generated from a PMU. When the battery voltage is too low, then the PMU might no more be able to generate $V_{DD(PAD)}$. When the device gets charged again, then $V_{DD(PAD)}$ is set up again.

As the pins to select the interface are biased from $V_{DD(PAD)}$, when $V_{DD(PAD)}$ disappears the pins might not be correctly biased internally and the information might be lost. Therefore it is required to make the IC boot after $V_{DD(PAD)}$ is set up again.

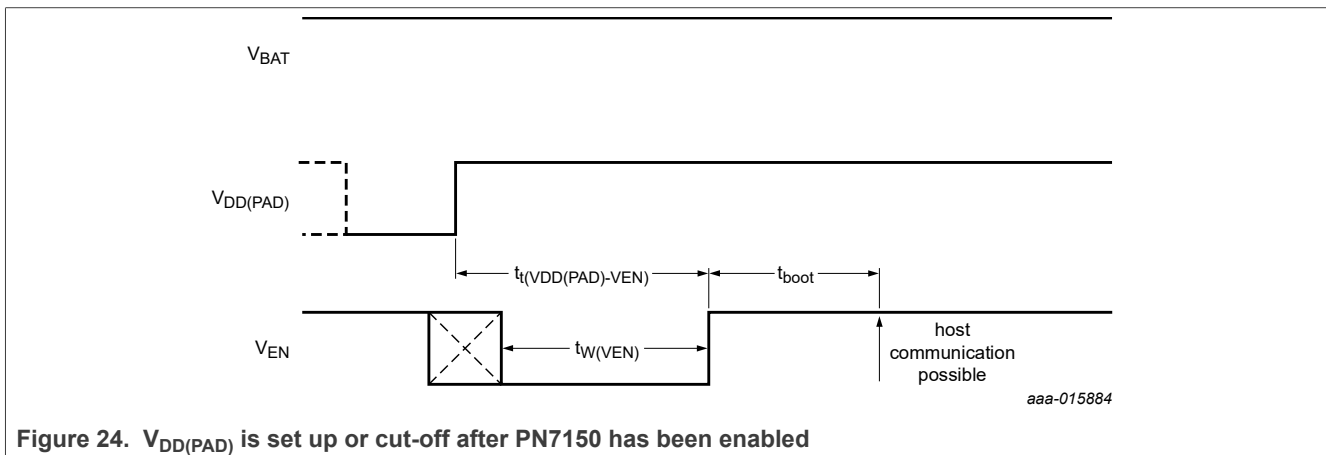

See [Section 16.2.3](#) for the timings values.

12.6.3 Power-down sequence

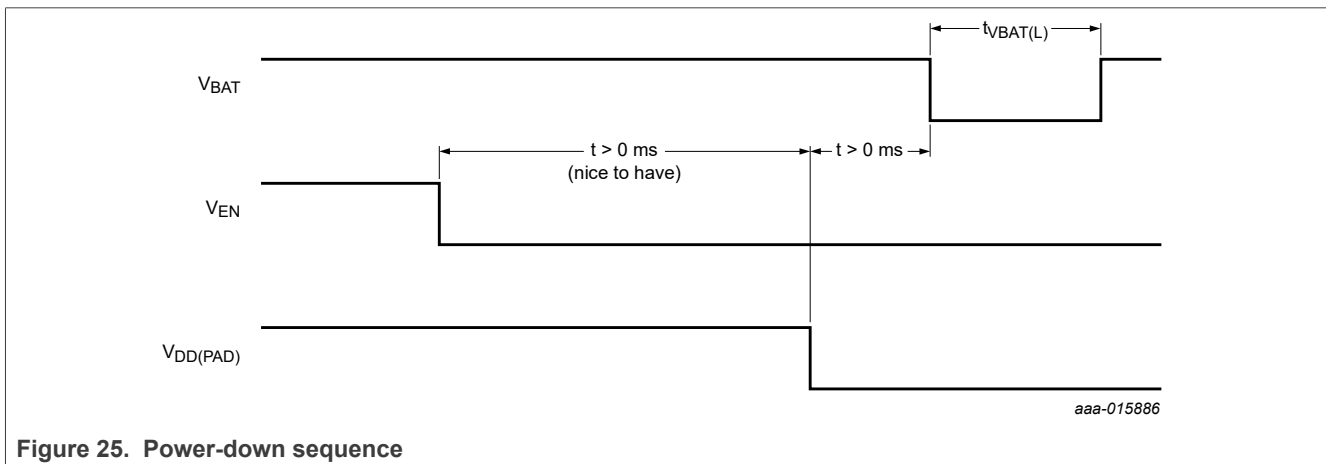

12.7 Contactless interface unit

PN7150 supports various communication modes at different transfer speeds and modulation schemes. The following sections describe selected communication modes.

Remark: all indicated modulation index and modes in this chapter are system parameters. This means that beside the IC settings a suitable antenna tuning is required to achieve the optimum performance.

12.7.1 Reader/Writer communication modes

Generally 5 Reader/Writer communication modes are supported:

- PCD Reader/Writer for ISO/IEC 14443 type A and for MIFARE Classic
- PCD Reader/Writer for Jewel/Topaz
- PCD Reader/Writer for FeliCa
- PCD Reader/Writer for ISO/IEC 14443B
- VCD Reader/Writer for ISO/IEC 15693/ICODE

High performance NFC controller with integrated firmware, supporting all NFC Forum modes

12.7.1.1 Communication mode for ISO/IEC 14443 type A, MIFARE Classic and Jewel/Topaz PCD

The ISO/IEC 14443A and MIFARE Classic PCD communication mode is the general reader to card communication scheme according to the ISO/IEC 14443A specification. This modulation scheme is as well used for communications with Jewel/Topaz cards.

Figure 26 describes the communication on a physical level, the communication table describes the physical parameters (the numbers take the antenna effect on modulation depth for higher data rates).

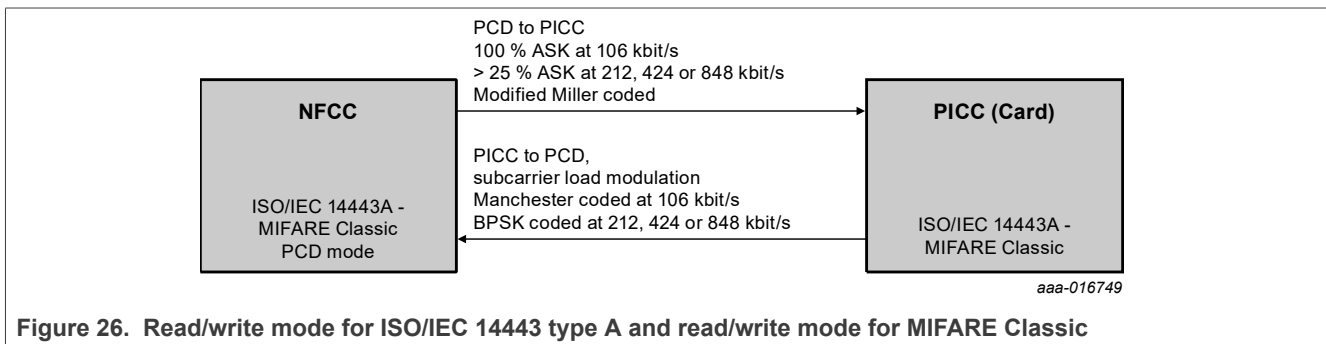

Table 16. Communication overview for ISO/IEC 14443 type A and read/write mode for MIFARE Classic

Communication direction	ISO/IEC 14443A/ MIFARE Classic/ Jewel/ Topaz		ISO/IEC 14443A higher transfer speeds		
	Transfer speed	106 kbit/s	212 kbit/s	424 kbit/s	848 kbit/s
	Bit length	(128/13.56) µs	(64/13.56) µs	(32/13.56) µs	(16/13.56) µs
PN7150 → PICC					
(data sent by PN7150 to a card)	modulation on PN7150 side	100 % ASK	> 25 % ASK	> 25 % ASK	> 25 % ASK
	bit coding	Modified Miller	Modified Miller	Modified Miller	Modified Miller
PICC → PN7150					
(data received by PN7150 from a card)	modulation on PICC side	subcarrier load modulation	subcarrier load modulation	subcarrier load modulation	subcarrier load modulation
	subcarrier frequency	13.56 MHz/16	13.56 MHz/16	13.56 MHz/16	13.56 MHz/16
	bit coding	Manchester	BPSK	BPSK	BPSK

The contactless coprocessor and the on-chip CPU of PN7150 handle the complete ISO/IEC 14443A and MIFARE Classic RF-protocol, nevertheless a dedicated external host has to handle the application layer communication.

12.7.1.2 FeliCa PCD communication mode

The FeliCa communication mode is the general Reader/Writer to card communication scheme according to the FeliCa specification. [Figure 27](#) describes the communication on a physical level, the communication overview describes the physical parameters.

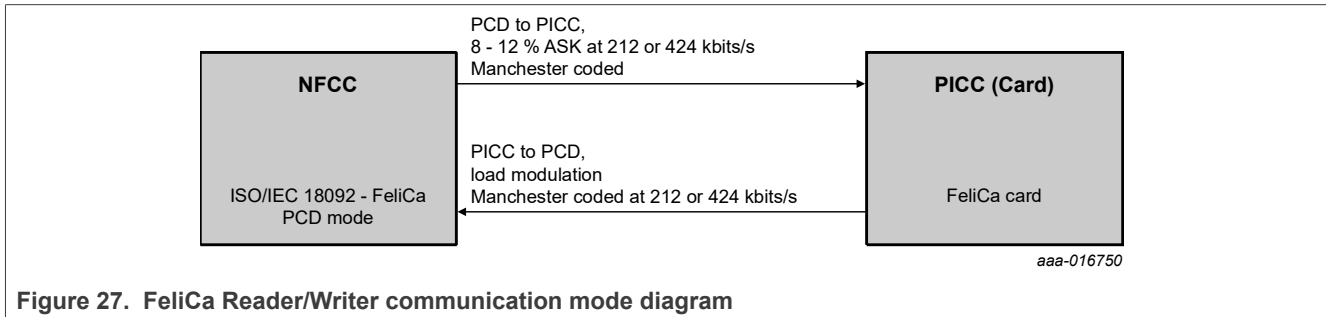

Figure 27. FeliCa Reader/Writer communication mode diagram

Table 17. Overview for FeliCa Reader/Writer communication mode

Communication direction		FeliCa	FeliCa higher transfer speeds
	Transfer speed	212 kbit/s	424 kbit/s
	Bit length	(64/13.56) μs	(32/13.56) μs
PN7150 → PICC			
(data sent by PN7150 to a card)	modulation on PN7150 side	8 % - 12 % ASK	8 % - 12 % ASK
	bit coding	Manchester	Manchester
PICC → PN7150			
(data received by PN7150 from a card)	modulation on PICC side	load modulation	load modulation
	subcarrier frequency	no subcarrier	no subcarrier
	bit coding	Manchester	Manchester

The contactless coprocessor of PN7150 and the on-chip CPU handle the FeliCa protocol. Nevertheless a dedicated external host has to handle the application layer communication.

12.7.1.3 ISO/IEC 14443B PCD communication mode

The ISO/IEC 14443B PCD communication mode is the general reader to card communication scheme according to the ISO/IEC 14443B specification. [Figure 28](#) describes the communication on a physical level, the communication table describes the physical parameters.

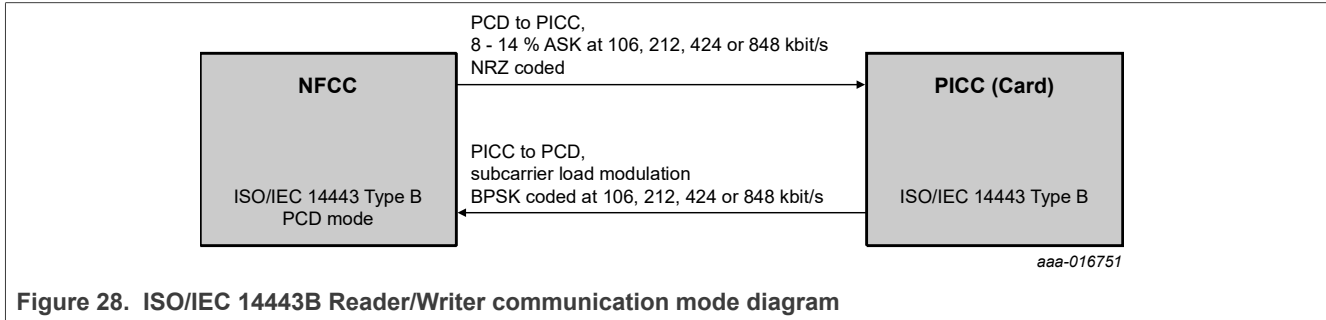

Figure 28. ISO/IEC 14443B Reader/Writer communication mode diagram

Table 18. Overview for ISO/IEC 14443B Reader/Writer communication mode

Communication direction	ISO/IEC 14443B		ISO/IEC 14443B higher transfer speeds		
	Transfer speed	106 kbit/s	212 kbit/s	424 kbit/s	848 kbit/s
	Bit length	(128/13.56) μ s	(64/13.56) μ s	(32/13.56) μ s	(16/13.56) μ s
PN7150 \rightarrow PICC					
(data sent by PN7150 to a card)	modulation on PN7150 side	8 % - 14 % ASK	8 % - 14 % ASK	8 % - 14 % ASK	8 % - 14 % ASK
	bit coding	NRZ	NRZ	NRZ	NRZ
PICC \rightarrow PN7150					
(data received by PN7150 from a card)	modulation on PICC side	subcarrier load modulation	subcarrier load modulation	subcarrier load modulation	subcarrier load modulation
	subcarrier frequency	13.56 MHz/16	13.56 MHz/16	13.56 MHz/16	13.56 MHz/16
	bit coding	BPSK	BPSK	BPSK	BPSK

The contactless coprocessor and the on-chip CPU of PN7150 handles the complete ISO/IEC 14443B RF-protocol, nevertheless a dedicated external host has to handle the application layer communication.

12.7.1.4 R/W mode for NFC forum Type 5 Tag

The R/W mode for NFC forum Type 5 Tag (T5T) is the general reader to card communication scheme according to the ISO/IEC 15693 specification. PN7150 communicates with VICC (Type 5 Tag) using only the 26.48 kbit/s with single subcarrier data rate of the VICC.

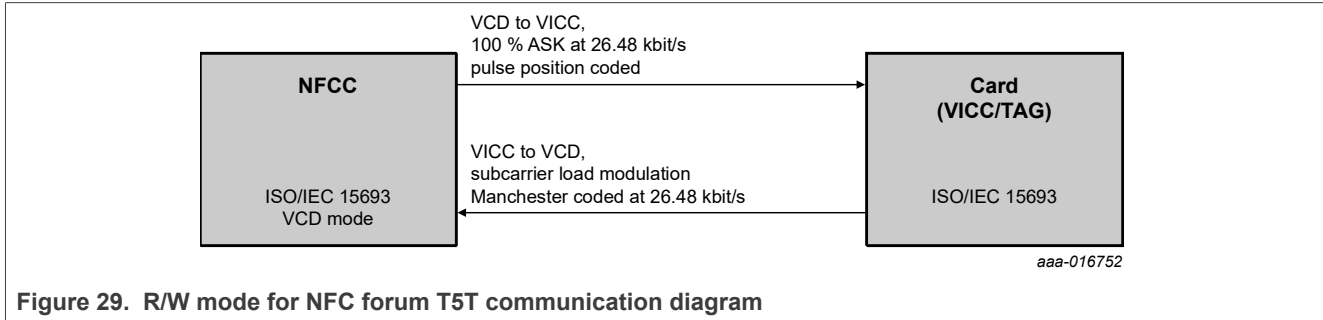

Figure 29. R/W mode for NFC forum T5T communication diagram

Figure 29 and Table 19 show the communication schemes used.

Table 19. Communication overview for NFC forum T5T R/W mode

Communication direction		
PN7150 → VICC		
(data sent by PN7150 to a tag)	transfer speed	26.48 kbit/s
	bit length	(512/13.56) μs
	modulation on PN7150 side	100 % ASK
	bit coding	pulse position modulation 1 out of 4 mode
VICC → PN7150		
(data received by PN7150 from a tag)	transfer speed	26.48 kbit/s
	bit length	(512/13.56) μs
	modulation on VICC side	subcarrier load modulation
	subcarrier frequency	single subcarrier
	bit coding	Manchester

12.7.2 ISO/IEC 18092, Ecma 340 NFCIP-1 communication modes

An NFCIP-1 communication takes place between 2 devices:

- NFC Initiator: generates RF field at 13.56 MHz and starts the NFCIP-1 communication.
- NFC Target: responds to NFC Initiator command either in a load modulation scheme in Passive communication mode or using a self-generated and self-modulated RF field for Active communication mode.

The NFCIP-1 communication differentiates between Active and Passive communication modes.

- Active communication mode means both the NFC Initiator and the NFC Target are using their own RF field to transmit data
- Passive communication mode means that the NFC Target answers to an NFC Initiator command in a load modulation scheme. The NFC Initiator is active in terms of generating the RF field.

PN7150 supports the Active Target, Active Initiator, Passive Target and Passive Initiator communication modes at the transfer speeds 106 kbit/s, 212 kbit/s and 424 kbit/s as defined in the NFCIP-1 standard.

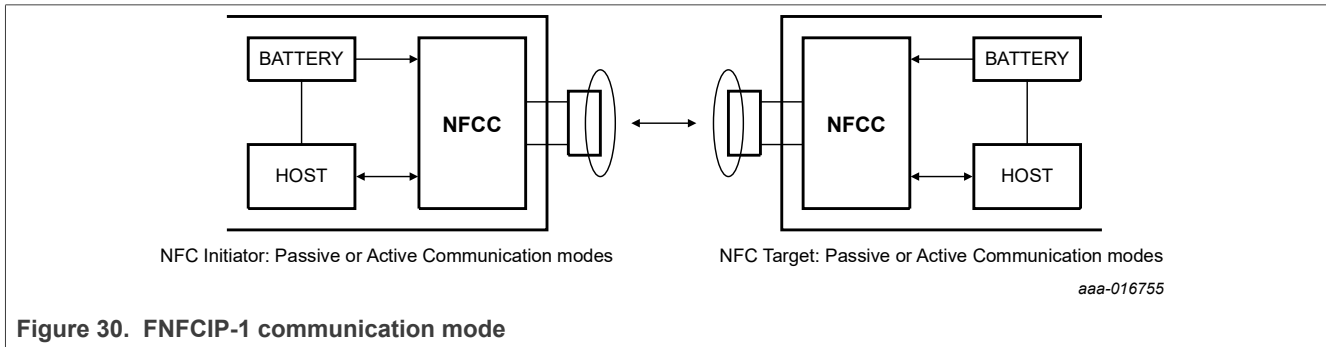

Figure 30. FNFCIP-1 communication mode

A dedicated external host handles the application layer communication.

12.7.2.1 ACTIVE communication mode

Active communication mode means both the NFC Initiator and the NFC Target are using their own RF field to transmit data.

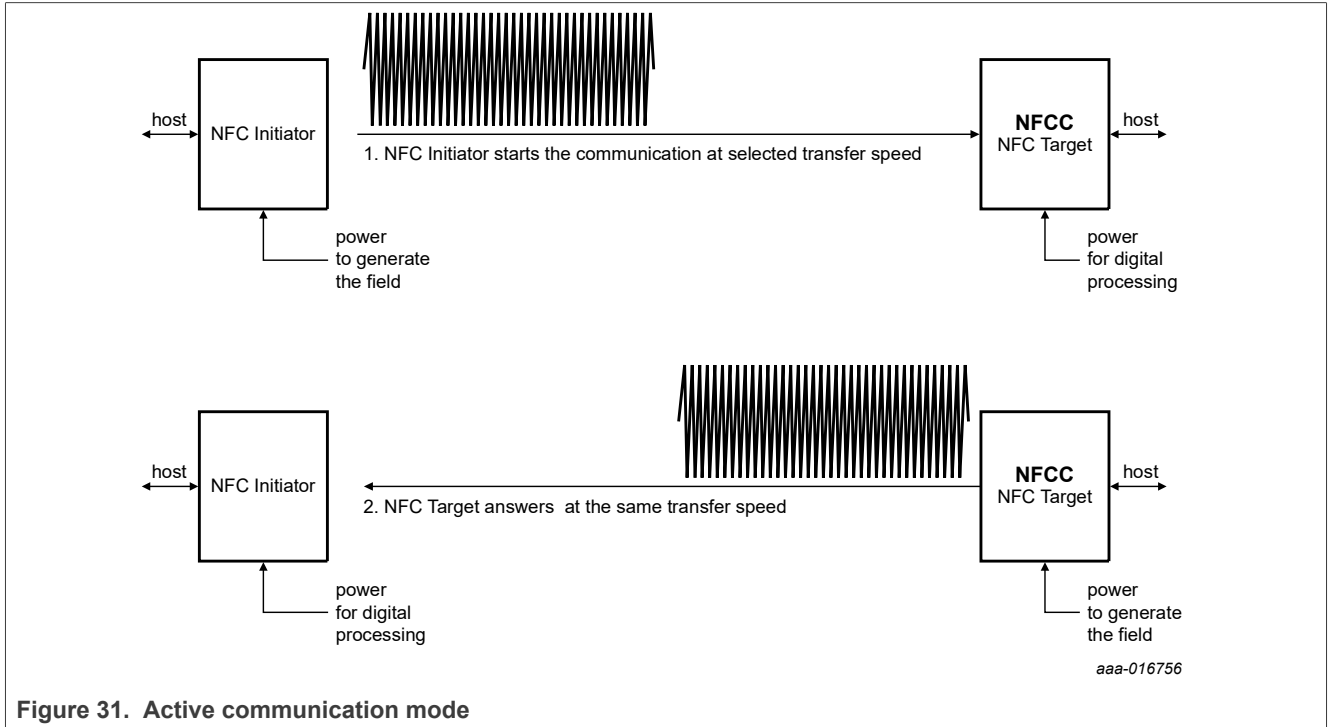

Figure 31. Active communication mode

The following table gives an overview of the Active communication modes:

Table 20. Overview for Active communication mode

Communication direction	ISO/IEC 18092, Ecma 340, NFCIP-1			
	Baud rate	106 kbit/s	212 kbit/s	424 kbit/s
	Bit length	(128/13.56) μs	(64/13.56) μs	(32/13.56) μs
NFC Initiator → NFC Target				
	modulation	100 % ASK	8 % - 30 % ASK ^[1]	8 % - 30 % ASK ^[1]
	bit coding	Modified Miller	Manchester	Manchester
NFC Target → NFC Initiator				
	modulation	100 % ASK	8 % - 30 % ASK ^[1]	8 % - 30 % ASK ^[1]
	bit coding	Miller	Manchester	Manchester

[1] This modulation index range is according to NFCIP-1 standard. It might be that some NFC forum type 3 cards does not withstand the full range as based on FeliCa range which is narrow (8 % to 14 % ASK).

12.7.2.2 Passive communication mode

Passive communication mode means that the NFC Target answers to an NFC Initiator command in a load modulation scheme.

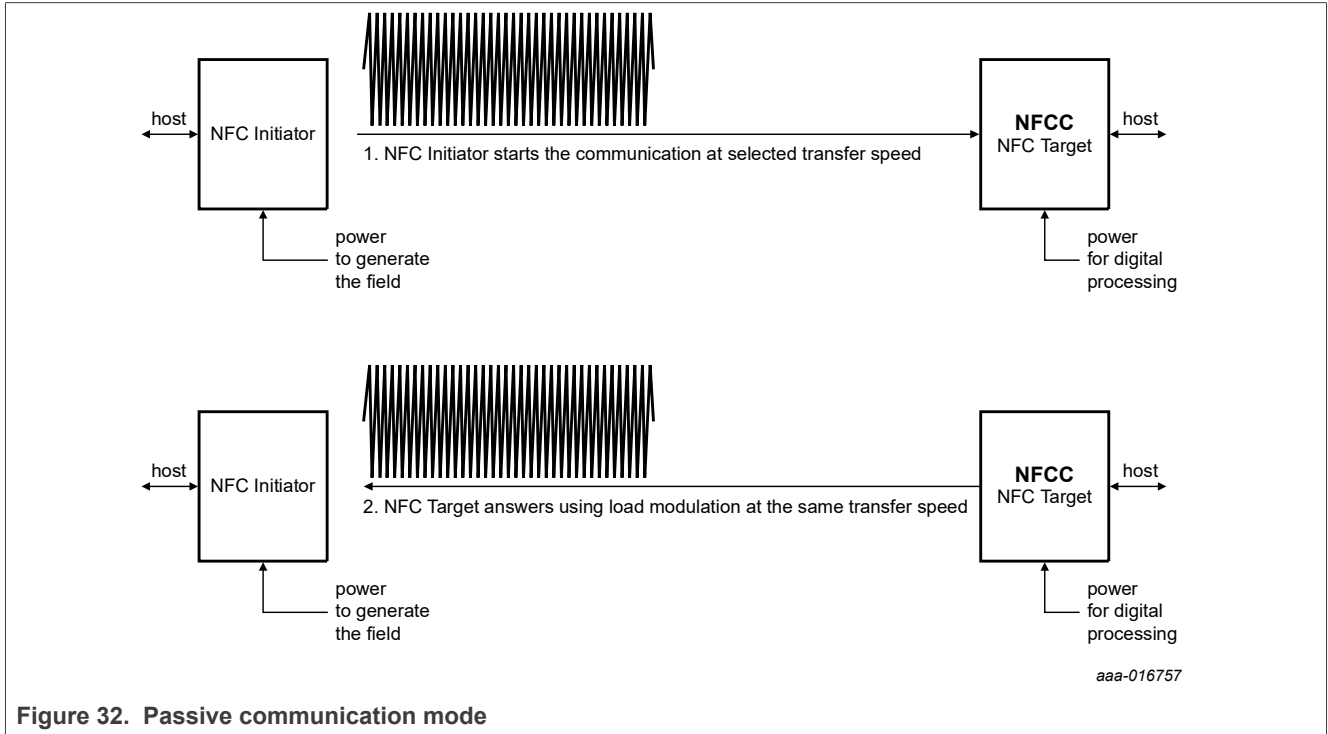

Table 21 gives an overview of the Passive communication modes:

Table 21. Overview for passive communication mode

Communication direction	ISO/IEC 18092, Ecma 340, NFCIP-1			
	Baud rate	106 kbit/s	212 kbit/s	424 kbit/s
	Bit length	(128/13.56) μ s	(64/13.56) μ s	(32/13.56) μ s
NFC Initiator → NFC Target				
	modulation	100 % ASK	8 % - 30 % ASK ^[1]	8 % - 30 % ASK ^[1]
	bit coding	Modified Miller	Manchester	Manchester
NFC Target → NFC Initiator				
	modulation	subcarrier load modulation	load modulation	load modulation
	subcarrier frequency	13.56 MHz/16	no subcarrier	no subcarrier
	bit coding	Manchester	Manchester	Manchester

[1] This modulation index range is according to NFCIP-1 standard. It might be that some NFC forum type 3 cards does not withstand the full range as based on FeliCa range which is narrow (8 % to 14 % ASK). To adjust the index, see [7].

12.7.2.3 NFCIP-1 framing and coding

The NFCIP-1 framing and coding in Active and Passive communication modes are defined in the NFCIP-1 standard: ISO/IEC 18092 or Ecma 340.

12.7.2.4 NFCIP-1 protocol support

The NFCIP-1 protocol is not completely described in this document. For detailed explanation of the protocol, refer to the ISO/IEC 18092 or Ecma 340 NFCIP-1 standard. However the datalink layer is according to the following policy:

- Transaction includes initialization, anticollision methods and data transfer. This sequence must not be interrupted by another transaction
- PSL shall be used to change the speed between the target selection and the data transfer, but the speed should not be changed during a data transfer

12.7.3 Card communication modes

PN7150 can be addressed as NFC forum T3T and T4T tags. This means that PN7150 can generate an answer in a load modulation scheme according to the ISO/IEC 14443A, ISO/IEC 14443B and the Sony FeliCa interface description.

Remark: *PN7150 does not support a complete card protocol. This has to be handled by the host controller.*

Table 20, Table 21 and Table 22 describe the physical parameters.

12.7.3.1 NFC forum T4T, ISO/IEC 14443A card mode

Table 22. Overview for NFC forum T4T, ISO/IEC 14443A card mode

Communication direction		ISO/IEC 14443A	ISO/IEC 14443A higher transfer speeds	
	Transfer speed	106 kbit/s	212 kbit/s	424 kbit/s
	Bit length	(128/13.56) μs	(64/13.56) μs	(32/13.56) μs
PCD → PN7150				
(data received by PN7150 from a card)	modulation on PCD side	100 % ASK	> 25 % ASK	> 25 % ASK
	bit coding	Modified Miller	Modified Miller	Modified Miller
PN7150 → PCD				
(data sent by PN7150 to a card)	modulation on PN7150 side	subcarrier load modulation	subcarrier load modulation	subcarrier load modulation
	subcarrier frequency	13.56 MHz/16	13.56 MHz/16	13.56 MHz/16
	bit coding	Manchester	BPSK	BPSK

12.7.3.2 NFC forum T4T, ISO/IEC 14443B card mode

Table 23. Overview for NFC forum T4T, ISO/IEC 14443B card mode

Communication direction		ISO/IEC 14443B	ISO/IEC 14443B higher transfer speeds	
	Transfer speed	106 kbit/s	212 kbit/s	424 kbit/s
	Bit length	(128/13.56) μ s	(64/13.56) μ s	(32/13.56) μ s
PCD \rightarrow PN7150				
(data received by PN7150 from a Reader)	modulation on PCD side	8 % - 14 % ASK	8 % - 14 % ASK	8 % - 14 % ASK
	bit coding	NRZ	NRZ	NRZ
PN7150 \rightarrow PCD				
(data sent by PN7150 to a Reader)	modulation on PN7150 side	subcarrier load modulation	subcarrier load modulation	subcarrier load modulation
	subcarrier frequency	13.56 MHz/16	13.56 MHz/16	13.56 MHz/16
	bit coding	BPSK	BPSK	BPSK

12.7.3.3 NFC forum T3T, Sony FeliCa card mode

Table 24. Overview for NFC forum T3T, Sony FeliCa card mode

Communication direction		FeliCa	FeliCa higher transfer speeds
	Transfer speed	212 kbit/s	424 kbit/s
	Bit length	(64/13.56) μ s	(32/13.56) μ s
PCD \rightarrow PN7150			
(data received by PN7150 from a Reader)	modulation on PN7150 side	8 % - 12 % ASK	8 % - 12 % ASK
	bit coding	Manchester	Manchester
PN7150 \rightarrow PCD			
(data sent by PN7150 to a Reader)	modulation on PICC side	load modulation	load modulation
	subcarrier frequency	no subcarrier	no subcarrier
	bit coding	Manchester	Manchester

12.7.4 Frequency interoperability

When in communication, PN7150 is generating some RF frequencies. PN7150 is also sensitive to some RF signals as it is looking for data in the field.

In order to avoid interference with others RF communication, it is required to tune the antenna and design the board according to [6].

Although ISO/IEC 14443 and ISO/IEC 18092/Ecma 340 allows an RF frequency of 13.56 MHz \pm 7 kHz, FCC regulation does not allow this wide spread and limits the dispersion to \pm 50 ppm, which is in line with PN7150 capability.

13 Limiting values

Table 25. Limiting values

In accordance with the Absolute Maximum Rating System (IEC 60134).

Symbol	Parameter	Conditions	Min	Max	Unit
V _{DD(PAD)}	V _{DD(PAD)} supply voltage	supply voltage for host interface	-	4.35	V
V _{BAT}	battery supply voltage		-	6	V
V _{ESD}	electrostatic discharge voltage	human body model (HBM) ^[1] ; 1500 Ω, 100 pF	-	1.5	kV
		charge device model (CDM) ^[2]	-	500	V
T _{stg}	storage temperature		-55	+150	°C
P _{tot}	total power dissipation	all modes	^[3] -	600	mW
V _{RXN(i)}	RXN input voltage		0	2.5	V
V _{RXP(i)}	RXP input voltage		0	2.5	V

[1] According to ANSI/ESDA/JEDEC JS-001.

[2] According to ANSI/ESDA/JEDEC JS-002

[3] The design of the solution shall be done so that for the different use cases targeted the power to be dissipated from the field or generated by PN7150 does not exceed this value.

14 Recommended operating conditions

Table 26. Operating conditions

Symbol	Parameter	Conditions		Min	Typ	Max	Unit
T_{amb}	ambient temperature	JEDEC PCB-0.5		-30	+25	+85	°C
V_{BAT}	battery supply voltage	battery monitor enabled; $V_{SS} = 0\text{ V}$	[1][1]	2.3	-	5.5	V
		Card Emulation and Passive Target; $V_{SS} = 0\text{ V}$	[1] [2]	2.3	-	5.5	V
		Reader, Active Initiator and Active Target; $V_{SS} = 0\text{ V}$	[1] [2]	2.7	-	5.5	V
$V_{DD(PAD)}$	$V_{DD(PAD)}$ supply voltage	supply voltage for host interface					
		• 1.8 V host supply; $V_{SS} = 0\text{ V}$	[1]	1.65	1.8	1.95	V
		• 3 V host supply; $V_{SS} = 0\text{ V}$	[1]	3.0	-	3.6	V
P_{tot}	total power dissipation	Reader; $I_{VDD(TX)} = 100\text{ mA}$; $V_{BAT} = 5.5\text{ V}$		-	-	420	mW
I_{BAT}	battery supply current	in Hard Power Down state; $V_{BAT} = 3.6\text{ V}$; $T = 25\text{ °C}$	[3]	-	10	14	μA
		in Standby state; $V_{BAT} = 3.6\text{ V}$; $T = 25\text{ °C}$		-	20	-	μA
		in Monitor state; $V_{BAT} = 2.75\text{ V}$; $T = 25\text{ °C}$		-	-	14	μA
		in low-power polling loop; $V_{BAT} = 3.6\text{ V}$; $T = 25\text{ °C}$; loop time = 500 ms	[4]	-	150	-	μA
		PCD mode at typical 3 V	[5]	-	-	190	mA
$I_{th(Ilim)}$	current limit threshold current	current limiter on $V_{DD(TX)}$ pin; $V_{DD(TX)} = 3.3\text{ V}$	[5]	-	180	-	mA

[1] V_{SS} represents $V_{SS(PAD)}$ and $V_{SS(TX)}$.

[2] The antenna should be tuned not to exceed this current limit (the detuning effect when coupling with another device must be taken into account).

[3] External clock on NFC_CLK_XTAL1 must be LOW.

[4] See [10] for computing the power consumption as it depends on several parameters.

[5] The antenna shall be tuned not to exceed the maximum of I_{BAT} .

15 Thermal characteristics

15.1 Thermal characteristics HVQFN40

Table 27. Thermal characteristics

Symbol	Parameter	Conditions	Min	Typ	Max	Unit
$R_{th(j-a)}$	thermal resistance from junction to ambient	in free air with exposed pad soldered on a 4 layer JEDEC PCB	-	40	-	K/W

15.2 Thermal characteristics WLCSP42

Table 28. Thermal characteristics

Symbol	Parameter	Conditions	Min	Typ	Max	Unit
$R_{th(j-a)}$	thermal resistance from junction to ambient	in free air with exposed pad soldered on a 4 layer JEDEC PCB	-	42	-	K/W

16 Characteristics

16.1 Current consumption characteristics

Table 29. Current consumption characteristics for operating ambient temperature range

Symbol	Parameter	Conditions	Min	Typ	Max	Unit
I _{BAT}	battery supply current	in Hard Power Down state; V _{BAT} = 3.6 V; VEN voltage = 0 V	-	10	20	μA
		in Standby state; V _{BAT} = 3.6 V;	[1] -	20	35	μA
		in Idle and Listener modes; V _{BAT} = 3.6 V	-	4.55	-	mA
		in Poller mode; V _{BAT} = 3.6 V	-	150	-	mA
		in Monitor state; V _{BAT} = 2.75 V	[2] -	10	20	μA

[1] Refer to [Section 12.1.2](#) for the description of the power modes.

[2] This is the same value for V_{BAT} = 2.3 V when the monitor threshold is set to 2.3 V.

16.2 Functional block electrical characteristics

16.2.1 Battery voltage monitor characteristics

Table 30. Battery voltage monitor characteristics

Symbol	Parameter	Conditions	Min	Typ	Max	Unit
V _{th}	threshold voltage	set to 2.3 V	2.15	2.3	2.45	V
		set to 2.75 V	2.6	2.75	2.9	V
V _{hys}	hysteresis voltage		100	150	200	mV

16.2.2 Reset via VEN

Table 31. Reset timing

Symbol	Parameter	Conditions	Min	Typ	Max	Unit
t _{W(VEN)}	VEN pulse width	to reset	10	-	-	μs
t _{boot}	boot time		-	-	2.5	ms

16.2.3 Power-up timings

Table 32. Power-up timings

Symbol	Parameter	Conditions	Min	Typ	Max	Unit
t _{t(VBAT-VEN)}	transition time from pin V _{BAT} to pin VEN	V _{BAT} , VEN voltage = HIGH	0	0.5	-	ms
t _{t(VDDPAD-VEN)}	transition time from pin V _{DD(PAD)} to pin VEN	V _{DD(PAD)} , VEN voltage = HIGH	0	0.5	-	ms
t _{t(VBAT-VDDPAD)}	transition time from pin V _{BAT} to pin V _{DD(PAD)}	V _{BAT} , V _{DD(PAD)} = HIGH	0	0.5	-	ms

16.2.4 Power-down timings

Table 33. Power-down timings

Symbol	Parameter	Conditions	Min	Typ	Max	Unit
t _{VBAT(L)}	time V _{BAT} LOW		20	-	-	ms

16.2.5 I²C-bus timings

Figure 33, Table 34, and Table 35 describe I²C-bus timings and frequency specifications.

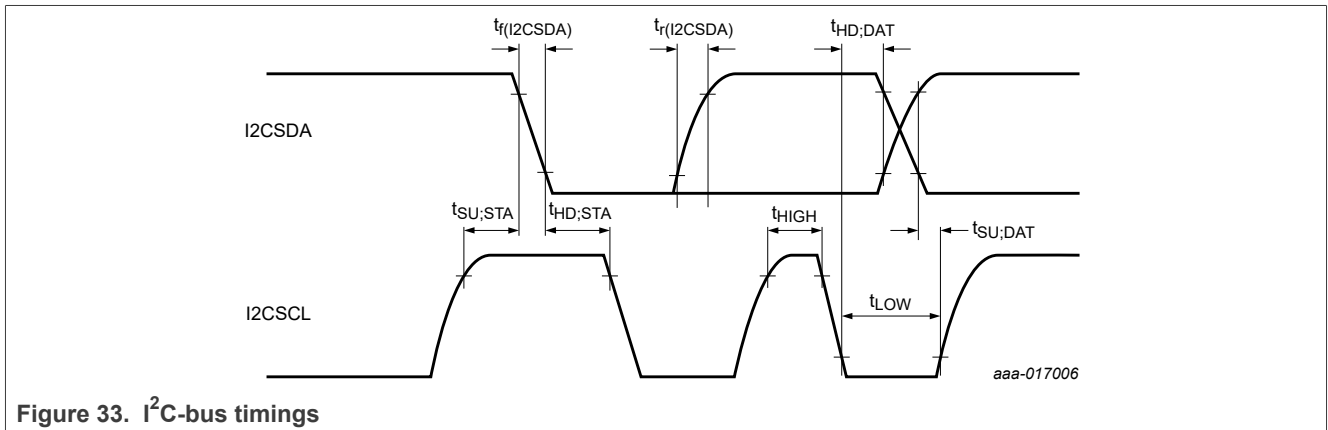

Figure 33. I²C-bus timings

Table 34. High-speed mode I²C-bus timings specification

Symbol	Parameter	Conditions	Min	Max	Unit
f _{clk(I2CSCL)}	clock frequency on pin I2CSCL	I ² C-bus SCL; C _b < 100 pF	0	3.4	MHz
t _{SU;STA}	set-up time for a repeated START condition	C _b < 100 pF	160	-	ns
t _{HD;STA}	hold time (repeated) START condition	C _b < 100 pF	160	-	ns
t _{LOW}	LOW period of the SCL clock	C _b < 100 pF	160	-	ns
t _{HIGH}	HIGH period of the SCL clock	C _b < 100 pF	60	-	ns
t _{SU;DAT}	data set-up time	C _b < 100 pF	10	-	ns
t _{HD;DAT}	data hold time	C _b < 100 pF	0	-	ns
t _{r(I2CSDA)}	rise time on pin I2CSDA	I ² C-bus SDA; C _b < 100 pF	10	80	ns
t _{f(I2CSDA)}	fall time on pin I2CSDA	I ² C-bus SDA; C _b < 100 pF	10	80	ns
V _{hys}	hysteresis voltage	Schmitt trigger inputs; C _b < 100 pF	0.1V _{DD(PAD)}	-	V

Table 35. Fast mode I²C-bus timings specification

Symbol	Parameter	Conditions	Min	Max	Unit
$f_{\text{clk(I2CSCL)}}$	clock frequency on pin I2CSCL	I ² C-bus SCL; $C_b < 400$ pF	0	400	kHz
$t_{\text{SU;STA}}$	set-up time for a repeated START condition	$C_b < 400$ pF	600	-	ns
$t_{\text{HD;STA}}$	hold time (repeated) START condition	$C_b < 400$ pF	600	-	ns
t_{LOW}	LOW period of the SCL clock	$C_b < 400$ pF	1.3	-	μ s
t_{HIGH}	HIGH period of the SCL clock	$C_b < 400$ pF	600	-	ns
$t_{\text{SU;DAT}}$	data set-up time	$C_b < 400$ pF	100	-	ns
$t_{\text{HD;DAT}}$	data hold time	$C_b < 400$ pF	0	900	ns
V_{hys}	hysteresis voltage	Schmitt trigger inputs; $C_b < 400$ pF	$0.1V_{\text{DD(PAD)}}$	-	V

16.3 Pin characteristics

16.3.1 NFC_CLK_XTAL1 and NFC_CLK_XTAL2 pins characteristics

Table 36. Input clock characteristics on NFC_CLK_XTAL1 when using PLL

Symbol	Parameter	Conditions	Min	Typ	Max	Unit
$V_{i(p-p)}$	peak-to-peak input voltage		0.2	-	1.8	V
δ	duty cycle		35	-	65	%

Table 37. Pin characteristics for NFC_CLK_XTAL1 when PLL input

Symbol	Parameter	Conditions	Min	Typ	Max	Unit
I_{IH}	HIGH-level input current	$V_I = V_{DD}$	-1	-	+1	μA
I_{IL}	LOW-level input current	$V_I = 0 V$	-1	-	+1	μA
V_i	input voltage		-	-	V_{DD}	V
$V_{i(clk)(p-p)}$	peak-to-peak clock input voltage		200	-	-	mV
C_i	input capacitance	all power modes	-	2	-	pF

Table 38. Pin characteristics for 27.12 MHz crystal oscillator

Symbol	Parameter	Conditions	Min	Typ	Max	Unit
$C_{i(NFC_CLK_XTAL1)}$	NFC_CLK_XTAL1 input capacitance	$V_{DD} = 1.8 V$	-	2	-	pF
$C_{i(NFC_CLK_XTAL2)}$	NFC_CLK_XTAL2 input capacitance		-	2	-	pF

Table 39. PLL accuracy

Symbol	Parameter	Conditions	Min	Typ	Max	Unit
$f_{o(acc)}$	output frequency accuracy	deviation added to NFC_CLK_XTAL1 frequency on RF frequency generated;worst case whatever input frequency	-50	-	+50	ppm

16.3.2 VEN input pin characteristics

Table 40. VEN input pin characteristics

Symbol	Parameter	Conditions	Min	Typ	Max	Unit
V_{IH}	HIGH-level input voltage		1.1	-	V_{BAT}	V
V_{IL}	LOW-level input voltage		0	-	0.4	V
I_{IH}	HIGH-level input current	VEN voltage = V_{BAT}	-1	-	+1	μA
I_{IL}	LOW-level input current	VEN voltage = 0 V	-1	-	+1	μA
C_i	input capacitance		-	5	-	pF

16.3.3 Pin characteristics for IRQ and CLK_REQ

Table 41. pin characteristics for IRQ and CLK_REQ

Symbol	Parameter	Conditions	Min	Typ	Max	Unit
V_{OH}	HIGH-level output voltage	$I_{OH} < 3 \text{ mA}$	$V_{DD(PAD)} - 0.4$	-	$V_{DD(PAD)}$	V
V_{OL}	LOW-level output voltage	$I_{OL} < 3 \text{ mA}$	0	-	0.4	V
C_L	load capacitance		-	-	20	pF
t_f	fall time	$C_L = 12 \text{ pF max}$				
		• high speed	1	-	3.5	ns
		• slow speed	2	-	10	ns
t_r	rise time	$C_L = 12 \text{ pF max}$				
		• high speed	1	-	3.5	ns
		• slow speed	2	-	10	ns
R_{pd}	pull-down resistance		^[1] 0.35	-	0.85	$M\Omega$

[1] Activated in HPD and Monitor states.

16.3.4 Input pin characteristics for RXN and RXP

Table 42. Input pin characteristics for RXN and RXP

Symbol	Parameter	Conditions	Min	Typ	Max	Unit
$V_{RXN(i)}$	RXN input voltage		0	-	V_{DD}	V
$V_{RXP(i)}$	RXP input voltage		0	-	V_{DD}	V
$C_{i(RXN)}$	RXN input capacitance		-	12	-	pF
$C_{i(RXP)}$	RXP input capacitance		-	12	-	pF
$Z_{i(RXN-VDDMID)}$	input impedance between RXN and $V_{DD(MID)}$	Reader, Card and P2P modes	0	-	15	k Ω
$Z_{i(RXP-VDDMID)}$	input impedance between RXP and $V_{DD(MID)}$	Reader, Card and P2P modes	0	-	15	k Ω
$V_{i(dyn)(RXN)}$	RXN dynamic input voltage	Miller coded				
		• 106 kbit/s	-	150	200	mV(p-p)
		• 212 kbit/s to 424 kbit/s	-	150	200	mV(p-p)
$V_{i(dyn)(RXP)}$	RXP dynamic input voltage	Miller coded				
		• 106 kbit/s	-	150	200	mV(p-p)
		• 212 kbit/s to 424 kbit/s	-	150	200	mV(p-p)
$V_{i(dyn)(RXN)}$	RXN dynamic input voltage	Manchester, NRZ or BPSK coded; 106 kbit/s to 848 kbit/s	-	150	200	mV(p-p)
$V_{i(dyn)(RXP)}$	RXP dynamic input voltage	Manchester, NRZ or BPSK coded; 106 kbit/s to 848 kbit/s	-	150	200	mV(p-p)
$V_{i(dyn)(RXN)}$	RXN dynamic input voltage	All data coding; 106 kbit/s to 848 kbit/s	V_{DD}	-	-	V(p-p)
$V_{i(dyn)(RXP)}$	RXP dynamic input voltage	All data coding; 106 kbit/s to 848 kbit/s	V_{DD}	-	-	V(p-p)
$V_{i(RF)}$	RF input voltage	RF input voltage detected; Initiator modes		100	-	mV(p-p)

16.3.5 Output pin characteristics for TX1 and TX2

Table 43. Output pin characteristics for TX1 and TX2

Symbol	Parameter	Conditions	Min	Typ	Max	Unit
V _{OH}	HIGH-level output voltage	V _{DD(TX)} = 3.3 V and I _{OH} = 30 mA; PMOS driver fully on	V _{DD(TX)} - 150	-	-	mV
V _{OL}	LOW-level output voltage	V _{DD(TX)} = 3.3 V and I _{OL} = 30 mA; NMOS driver fully on	-	-	200	mV

Table 44. Output resistance for TX1 and TX2

Symbol	Parameter	Conditions	Min	Typ	Max	Unit
R _{OL}	LOW-level output resistance	V _{DD(TX)} - 100 mV; CWGsN = 01h	-	-	85	Ω
R _{OL}	LOW-level output resistance	V _{DD(TX)} - 100 mV; CWGsN = 0Fh	-	-	5	Ω
R _{OH}	HIGH-level output resistance	V _{DD(TX)} - 100 mV	-	-	4	Ω

16.3.6 Input pin characteristics for I2CADR0 and I2CADR1

Table 45. Input pin characteristics for I2CADR0 and I2CADR1

Symbol	Parameter	Conditions	Min	Typ	Max	Unit
V _{IH}	HIGH-level input voltage		0.65V _{DD(PAD)}	-	V _{DD(PAD)}	V
V _{IL}	LOW-level input voltage		0	-	0.35V _{DD(PAD)}	V
I _{IH}	HIGH-level input current	V _I = V _{DD(PAD)}	-1	-	+1	μA
I _{IL}	LOW-level input current	V _I = 0 V	-1	-	+1	μA
C _i	input capacitance		-	5	-	pF

16.3.7 Pin characteristics for I2CSDA and I2CSCL

Table 46. Pin characteristics for I2CSDA and I2CSCL

Symbol	Parameter	Conditions	Min	Typ	Max	Unit
V_{OL}	LOW-level output voltage	$I_{OL} < 3 \text{ mA}$	[1] 0	-	0.4	V
C_L	load capacitance		-	-	10	pF
t_f	fall time	$C_L = 100 \text{ pF}; R_{pull-up} = 2 \text{ k}\Omega$; Standard and Fast mode	[1] 30	-	250	ns
t_f	fall time	$C_L = 100 \text{ pF}; R_{pull-up} = 1 \text{ k}\Omega$; High-speed mode	[1] 80	-	110	ns
t_r	rise time	$C_L = 100 \text{ pF}; R_{pull-up} = 2 \text{ k}\Omega$; Standard and Fast mode	[1] 30	-	250	ns
		$C_L = 100 \text{ pF}; R_{pull-up} = 1 \text{ k}\Omega$; High-speed mode	[1] 10	-	100	ns
V_{IH}	HIGH-level input voltage		$0.7V_{DD(PAD)}$	-	$V_{DD(PAD)}$	V
V_{IL}	LOW-level input voltage		0	-	$0.3V_{DD(PAD)}$	V
I_{IH}	HIGH-level input current	$V_I = V_{DD(PAD)}$; high impedance	-1	-	+1	μA
I_{IL}	LOW-level input current	$V_I = 0 \text{ V}$; high impedance	-1	-	+1	μA
C_i	input capacitance		-	5	-	pF

[1] Only for pin I2CSDA as I2CSCL is only used as input.

16.3.8 V_{DD} pin characteristic

Table 47. Electrical characteristic of V_{DD}

Symbol	Parameter	Conditions	Min	Typ	Max	Unit
V_{DD}	V_{DD} supply voltage	$V_{SS} = 0 \text{ V}$	1.65	1.8	1.95	V

17 Package outline

17.1 Package outline HVQFN40

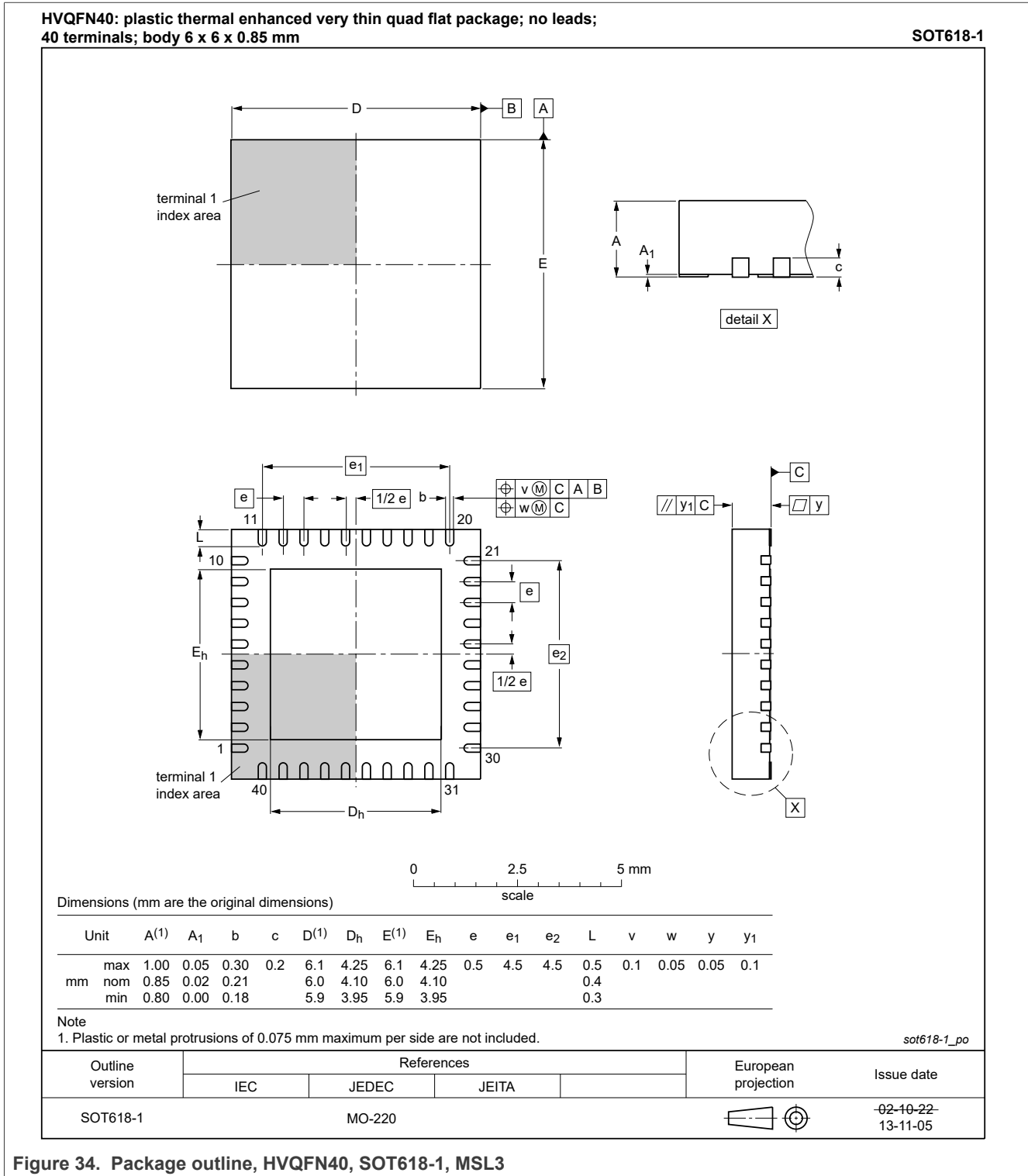

Figure 34. Package outline, HVQFN40, SOT618-1, MSL3

17.2 Package outline WLCSP42

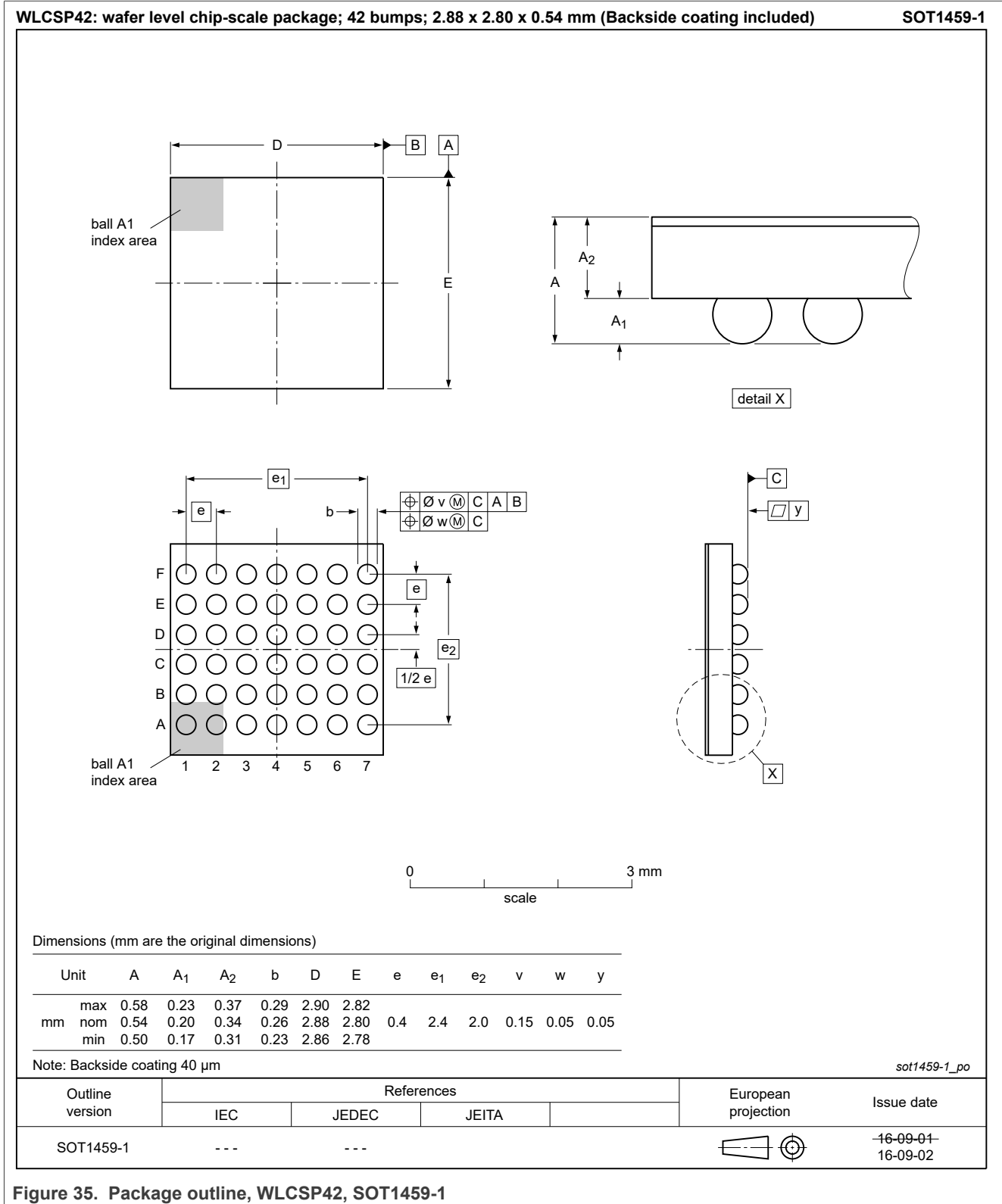

Figure 35. Package outline, WLCSP42, SOT1459-1

18 Soldering of SMD packages

This text provides a very brief insight into a complex technology. A more in-depth account of soldering ICs can be found in Application Note AN10365 "Surface mount reflow soldering description".

18.1 Introduction to soldering

Soldering is one of the most common methods through which packages are attached to Printed Circuit Boards (PCBs), to form electrical circuits. The soldered joint provides both the mechanical and the electrical connection. There is no single soldering method that is ideal for all IC packages. Wave soldering is often preferred when through-hole and Surface Mount Devices (SMDs) are mixed on one printed wiring board; however, it is not suitable for fine pitch SMDs. Reflow soldering is ideal for the small pitches and high densities that come with increased miniaturization.

18.2 Wave and reflow soldering

Wave soldering is a joining technology in which the joints are made by solder coming from a standing wave of liquid solder. The wave soldering process is suitable for the following:

- Through-hole components
- Leaded or leadless SMDs, which are glued to the surface of the printed circuit board

Not all SMDs can be wave soldered. Packages with solder balls, and some leadless packages which have solder lands underneath the body, cannot be wave soldered. Also, leaded SMDs with leads having a pitch smaller than ~0.6 mm cannot be wave soldered, due to an increased probability of bridging.

The reflow soldering process involves applying solder paste to a board, followed by component placement and exposure to a temperature profile. Leaded packages, packages with solder balls, and leadless packages are all reflow solderable.

Key characteristics in both wave and reflow soldering are:

- Board specifications, including the board finish, solder masks and vias
- Package footprints, including solder thieves and orientation
- The moisture sensitivity level of the packages
- Package placement
- Inspection and repair
- Lead-free soldering versus SnPb soldering

18.3 Wave soldering

Key characteristics in wave soldering are:

- Process issues, such as application of adhesive and flux, clinching of leads, board transport, the solder wave parameters, and the time during which components are exposed to the wave
- Solder bath specifications, including temperature and impurities

18.4 Reflow soldering

Key characteristics in reflow soldering are:

- Lead-free versus SnPb soldering; note that a lead-free reflow process usually leads to higher minimum peak temperatures (see [Figure 36](#)) than a SnPb process, thus reducing the process window.
- Solder paste printing issues including smearing, release, and adjusting the process window for a mix of large and small components on one board.
- Reflow temperature profile; this profile includes preheat, reflow (in which the board is heated to the peak temperature) and cooling down. It is imperative that the peak temperature is high enough for the solder to make reliable solder joints (a solder paste characteristic). In addition, the peak temperature must be low enough that the packages and/or boards are not damaged. The peak temperature of the package depends on package thickness and volume and is classified in accordance with [Table 48](#) and [Table 49](#).

Table 48. SnPb eutectic process (from J-STD-020D)

Package thickness (mm)	Package reflow temperature (°C)	
	Volume (mm ³)	
	< 350	≥ 350
< 2.5	235	220
≥ 2.5	220	220

Table 49. Lead-free process (from J-STD-020D)

Package thickness (mm)	Package reflow temperature (°C)		
	Volume (mm ³)		
	< 350	350 to 2 000	> 2 000
< 1.6	260	260	260
1.6 to 2.5	260	250	245
> 2.5	250	245	245

Moisture sensitivity precautions, as indicated on the packing, must be respected at all times.

Studies have shown that small packages reach higher temperatures during reflow soldering, see [Figure 36](#).

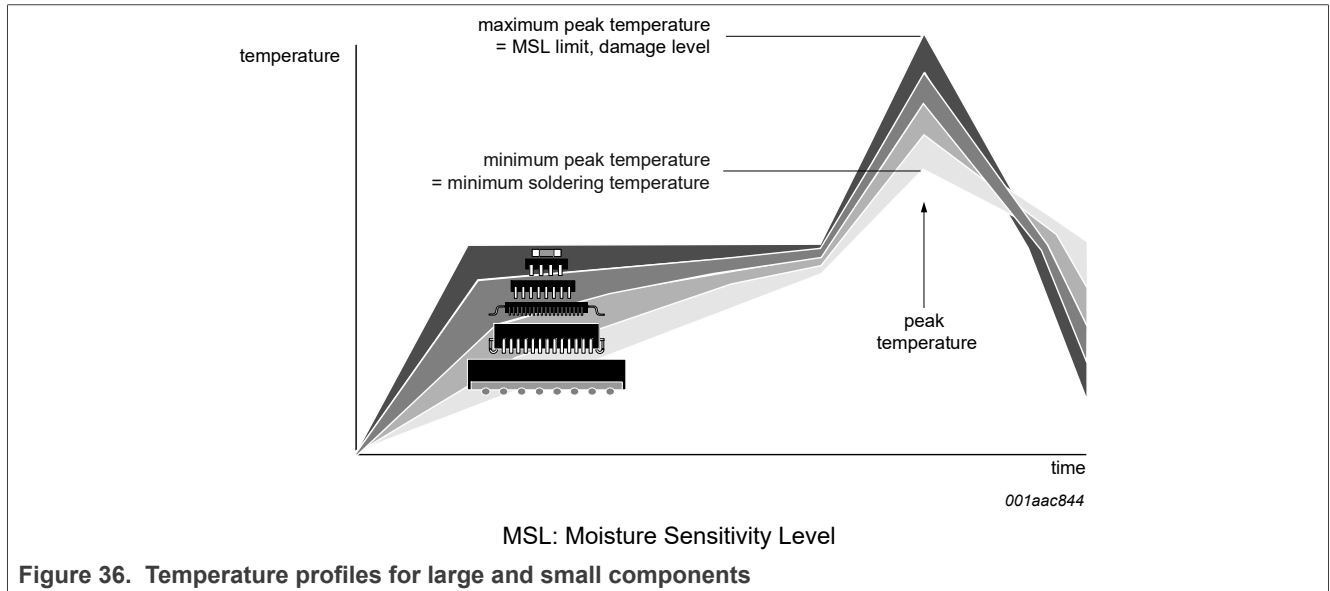

Figure 36. Temperature profiles for large and small components

For further information on temperature profiles, refer to [\[12\]](#).

19 Abbreviations

Table 50. Abbreviations

Acronym	Description
API	Application Programming Interface
ASK	Amplitude Shift keying
ASK modulation index	The ASK modulation index is defined as the voltage ratio $(V_{max} - V_{min}) / (V_{max} + V_{min}) \times 100\%$
Automatic device discovery	Detect and recognize any NFC peer devices (initiator or target) like: NFC initiator or target, ISO/IEC 14443-3, -4 Type A&B PICC, MIFARE Classic and MIFARE Ultralight PICC, ISO/IEC 15693 VICC
BPSK	Bit Phase Shift Keying
Card Emulation	The IC is capable of handling a PICC emulation on the RF interface including part of the protocol management. The application handling is done by the host controller
DEP	Data Exchange Protocol
DSLDO	Dual Supplied LDO
FW	FirmWare
HPD	Hard Power Down
LDO	Low Drop Out
LFO	Low Frequency Oscillator
MOSFET	Metal Oxide Semiconductor Field Effect Transistor
MSL	Moisture Sensitivity Level
NCI	NFC Controller Interface
NFC	Near Field Communication
NFCC	NFC Controller, PN7150 in this data sheet
NFC Initiator	Initiator as defined in ISO/IEC 18092 or ECma 340: NFCIP-1 communication
NFCIP	NFC Interface and Protocol
NFC Target	Target as defined in ISO/IEC 18092 or ECma 340: NFCIP-1 communication
NRZ	Non-Return to Zero
P2P	Peer to Peer
PCD	Proximity Coupling Device. Definition for a Card reader/writer device according to the ISO/IEC 14443 specification or MIFARE Classic
PCD -> PICC	Communication flow between a PCD and a PICC according to the ISO/IEC 14443 specification or MIFARE Classic
PICC	Proximity Interface Coupling Card. Definition for a contactless Smart Card according to the ISO/IEC 14443 specification or MIFARE Classic
PICC-> PCD	Communication flow between a PICC and a PCD according to the ISO/IEC 14443 specification or MIFARE Classic
PMOS	P-channel MOSFET
PMU	Power Management Unit

Table 50. Abbreviations...continued

Acronym	Description
PSL	Parameter SeLection
TXLDO	Transmitter LDO
UM	User Manual
VCD	Vicinity Coupling Device. Definition for a reader/writer device according to the ISO/IEC 15693 specification
VCO	Voltage Controlled Oscillator
VICC	Vicinity Integrated Circuit Card
WUC	Wake-Up Counter

20 References

- [1] NFC Forum Device Requirements V1.3
- [2] NFC Controller Interface (NCI) Technical Specification V1.0
- [3] ISO/IEC 14443 parts 2: 2001 COR 1 2007 (01/11/2007), part 3: 2001 COR 1 2006 (01/09/2006) and part 4: 2nd edition 2008 (15/07/2008)
- [4] UM10204 I²C-bus Specification and User Manual ([link](#))
- [5] UM10936 - PN7150 User Manual ([link](#))
- [6] AN11756 - PN7150 Hardware Design Guide ([link](#))
- [7] AN11755 - PN7150 Antenna Design and Matching Guide ([link](#))
- [8] ISO/IEC 18092 (NFCIP-1) edition, 15/03/2013. This is similar to Ecma 340.
- [9] ISO/IEC 15693 part 2: 2nd edition (15/12/2006), part 3: 1st edition (01/04/2001)
- [10] AN11757 - PN7150 Low-Power Mode Configuration ([link](#))
- [11] ISO/IEC 21481 (NFCIP-2) edition, 01/07/2012. This is similar to Ecma 352.
- [12] AN10365 - Surface Mount Reflow Soldering Description ([link](#))

21 Revision history

Table 51. Revision history

Document ID	Release date	Data sheet status	Change notice	Supersedes
PN7150 v4.2	20240202	Product data sheet		PN7150 v4.1
Modifications:	<ul style="list-style-type: none"> • Section 8 "Marking HVQFN40": updated the firmware version. • Section 9 "Marking WLCSP42": updated the firmware version. 			
PN7150 v4.1	20230127	Product data sheet	-	PN7150 v4.0
Modifications:	<ul style="list-style-type: none"> • Statement added that "The product version C11006 does not support the standby mode. The standby is not supported, also during the polling sequence. " in Section 6.1 and Section 7 			
PN7150 v4.0	20200625	Product data sheet	-	PN7150 v3.9
Modifications:	<ul style="list-style-type: none"> • Included new product type PN7150B0HN/C11006 • Marked PN7150B0UK/C11002 to be come discontinued • Added information about withdrawal of PN7150B0HN/C11004 			
PN7150 v3.9	20190828	Product data sheet	-	PN7150 v3.8
Modifications:	<ul style="list-style-type: none"> • Added a version history of the different firmware versions, see Section 6 			
PN7150 v3.8	20181030	Product data sheet	-	PN7150 v3.7
Modifications:	<ul style="list-style-type: none"> • Section 12 "Functional description": added a note regarding EEPROM memory. 			
PN7150 v3.7	20180424	Product data sheet	-	PN7150 v3.6
Modifications:	<ul style="list-style-type: none"> • Section 12.6.1: fixed some cross references. 			
PN7150 v3.6	20171127	Product data sheet	-	PN7150 v3.5
Modifications:	<ul style="list-style-type: none"> • Minor typos corrected. • Included new product type PN7150B0UK/C11002 			
PN7150 v3.5	20171018	Product data sheet	-	PN7150 v3.4
Modifications:	<ul style="list-style-type: none"> • Table 19 "Communication overview for NFC forum T5T R/W mode": updated. 			
PN7150 v3.4	20171004	Product data sheet	-	PN7150 v3.3
Modifications:	<ul style="list-style-type: none"> • Descriptive title updated • Section 2: updated the figure. • Updated MIFARE branding. 			
PN7150 v3.3	20160704	Product data sheet	-	PN7150 v3.2
Modifications:	<ul style="list-style-type: none"> • Figure 1: updated. • Section 12.7.1.4 "R/W mode for NFC forum Type 5 Tag": updated. • Section 12.7.3 "Card communication modes": updated. 			
PN7150 v3.2	201600525	Product data sheet	-	PN7150 v3.1
PN7150 v3.1	20160511	Product data sheet	-	PN7150 v3.0
PN7150 v3.0	20151209	Product data sheet	-	PN7150 v2.1
PN7150 v2.1	20151127	Preliminary data sheet	-	PN7150 v2.0
PN7150 v2.0	20150701	Preliminary data sheet	-	PN7150 v1.2
PN7150 v1.2	20150625	Objective data sheet	-	PN7150 v1.1
PN7150 v1.1	20150212	Objective data sheet	-	PN7150 v1.0

High performance NFC controller with integrated firmware, supporting all NFC Forum modes

Table 51. Revision history...continued

Document ID	Release date	Data sheet status	Change notice	Supersedes
PN7150 v1.0	20150129	Objective data sheet	-	-
Modifications:	• Initial version			

Legal information

Data sheet status

Document status ^{[1][2]}	Product status ^[3]	Definition
Objective [short] data sheet	Development	This document contains data from the objective specification for product development.
Preliminary [short] data sheet	Qualification	This document contains data from the preliminary specification.
Product [short] data sheet	Production	This document contains the product specification.

[1] Please consult the most recently issued document before initiating or completing a design.

[2] The term 'short data sheet' is explained in section "Definitions".

[3] The product status of device(s) described in this document may have changed since this document was published and may differ in case of multiple devices. The latest product status information is available on the Internet at URL <https://www.nxp.com>.

Definitions

Draft — A draft status on a document indicates that the content is still under internal review and subject to formal approval, which may result in modifications or additions. NXP Semiconductors does not give any representations or warranties as to the accuracy or completeness of information included in a draft version of a document and shall have no liability for the consequences of use of such information.

Short data sheet — A short data sheet is an extract from a full data sheet with the same product type number(s) and title. A short data sheet is intended for quick reference only and should not be relied upon to contain detailed and full information. For detailed and full information see the relevant full data sheet, which is available on request via the local NXP Semiconductors sales office. In case of any inconsistency or conflict with the short data sheet, the full data sheet shall prevail.

Product specification — The information and data provided in a Product data sheet shall define the specification of the product as agreed between NXP Semiconductors and its customer, unless NXP Semiconductors and customer have explicitly agreed otherwise in writing. In no event however, shall an agreement be valid in which the NXP Semiconductors product is deemed to offer functions and qualities beyond those described in the Product data sheet.

Disclaimers

Limited warranty and liability — Information in this document is believed to be accurate and reliable. However, NXP Semiconductors does not give any representations or warranties, expressed or implied, as to the accuracy or completeness of such information and shall have no liability for the consequences of use of such information. NXP Semiconductors takes no responsibility for the content in this document if provided by an information source outside of NXP Semiconductors.

In no event shall NXP Semiconductors be liable for any indirect, incidental, punitive, special or consequential damages (including - without limitation - lost profits, lost savings, business interruption, costs related to the removal or replacement of any products or rework charges) whether or not such damages are based on tort (including negligence), warranty, breach of contract or any other legal theory.

Notwithstanding any damages that customer might incur for any reason whatsoever, NXP Semiconductors' aggregate and cumulative liability towards customer for the products described herein shall be limited in accordance with the Terms and conditions of commercial sale of NXP Semiconductors.

Right to make changes — NXP Semiconductors reserves the right to make changes to information published in this document, including without limitation specifications and product descriptions, at any time and without notice. This document supersedes and replaces all information supplied prior to the publication hereof.

Suitability for use — NXP Semiconductors products are not designed, authorized or warranted to be suitable for use in life support, life-critical or safety-critical systems or equipment, nor in applications where failure or malfunction of an NXP Semiconductors product can reasonably be expected to result in personal injury, death or severe property or environmental damage. NXP Semiconductors and its suppliers accept no liability for inclusion and/or use of NXP Semiconductors products in such equipment or applications and therefore such inclusion and/or use is at the customer's own risk.

Applications — Applications that are described herein for any of these products are for illustrative purposes only. NXP Semiconductors makes no representation or warranty that such applications will be suitable for the specified use without further testing or modification.

Customers are responsible for the design and operation of their applications and products using NXP Semiconductors products, and NXP Semiconductors accepts no liability for any assistance with applications or customer product design. It is customer's sole responsibility to determine whether the NXP Semiconductors product is suitable and fit for the customer's applications and products planned, as well as for the planned application and use of customer's third party customer(s). Customers should provide appropriate design and operating safeguards to minimize the risks associated with their applications and products.

NXP Semiconductors does not accept any liability related to any default, damage, costs or problem which is based on any weakness or default in the customer's applications or products, or the application or use by customer's third party customer(s). Customer is responsible for doing all necessary testing for the customer's applications and products using NXP Semiconductors products in order to avoid a default of the applications and the products or of the application or use by customer's third party customer(s). NXP does not accept any liability in this respect.

Limiting values — Stress above one or more limiting values (as defined in the Absolute Maximum Ratings System of IEC 60134) will cause permanent damage to the device. Limiting values are stress ratings only and (proper) operation of the device at these or any other conditions above those given in the Recommended operating conditions section (if present) or the Characteristics sections of this document is not warranted. Constant or repeated exposure to limiting values will permanently and irreversibly affect the quality and reliability of the device.

Terms and conditions of commercial sale — NXP Semiconductors products are sold subject to the general terms and conditions of commercial sale, as published at <https://www.nxp.com/profile/terms>, unless otherwise agreed in a valid written individual agreement. In case an individual agreement is concluded only the terms and conditions of the respective agreement shall apply. NXP Semiconductors hereby expressly objects to applying the customer's general terms and conditions with regard to the purchase of NXP Semiconductors products by customer.

No offer to sell or license — Nothing in this document may be interpreted or construed as an offer to sell products that is open for acceptance or the grant, conveyance or implication of any license under any copyrights, patents or other industrial or intellectual property rights.

High performance NFC controller with integrated firmware, supporting all NFC Forum modes

Quick reference data — The Quick reference data is an extract of the product data given in the Limiting values and Characteristics sections of this document, and as such is not complete, exhaustive or legally binding.

Export control — This document as well as the item(s) described herein may be subject to export control regulations. Export might require a prior authorization from competent authorities.

Suitability for use in non-automotive qualified products — Unless this document expressly states that this specific NXP Semiconductors product is automotive qualified, the product is not suitable for automotive use. It is neither qualified nor tested in accordance with automotive testing or application requirements. NXP Semiconductors accepts no liability for inclusion and/or use of non-automotive qualified products in automotive equipment or applications.

In the event that customer uses the product for design-in and use in automotive applications to automotive specifications and standards, customer (a) shall use the product without NXP Semiconductors' warranty of the product for such automotive applications, use and specifications, and (b) whenever customer uses the product for automotive applications beyond NXP Semiconductors' specifications such use shall be solely at customer's own risk, and (c) customer fully indemnifies NXP Semiconductors for any liability, damages or failed product claims resulting from customer design and use of the product for automotive applications beyond NXP Semiconductors' standard warranty and NXP Semiconductors' product specifications.

Translations — A non-English (translated) version of a document, including the legal information in that document, is for reference only. The English version shall prevail in case of any discrepancy between the translated and English versions.

Security — Customer understands that all NXP products may be subject to unidentified vulnerabilities or may support established security standards or specifications with known limitations. Customer is responsible for the design and operation of its applications and products throughout their lifecycles to reduce the effect of these vulnerabilities on customer's applications and products. Customer's responsibility also extends to other open and/or proprietary technologies supported by NXP products for use in customer's applications. NXP accepts no liability for any vulnerability. Customer should regularly check security updates from NXP and follow up appropriately. Customer shall select products with security features that best meet rules, regulations, and standards of the intended application and make the ultimate design decisions regarding its products and is solely responsible for compliance with all legal, regulatory, and security related requirements concerning its products, regardless of any information or support that may be provided by NXP.

NXP has a Product Security Incident Response Team (PSIRT) (reachable at PSIRT@nxp.com) that manages the investigation, reporting, and solution release to security vulnerabilities of NXP products.

NXP B.V. — NXP B.V. is not an operating company and it does not distribute or sell products.

Licenses

Purchase of NXP ICs with NFC technology — Purchase of an NXP Semiconductors IC that complies with one of the Near Field Communication (NFC) standards ISO/IEC 18092 and ISO/IEC 21481 does not convey an implied license under any patent right infringed by implementation of any of those standards. Purchase of NXP Semiconductors IC does not include a license to any NXP patent (or other IP right) covering combinations of those products with other products, whether hardware or software.

Trademarks

Notice: All referenced brands, product names, service names, and trademarks are the property of their respective owners.

NXP — wordmark and logo are trademarks of NXP B.V.

AMBA, Arm, Arm7, Arm7TDMI, Arm9, Arm11, Artisan, big.LITTLE, Cordio, CoreLink, CoreSight, Cortex, DesignStart, DynamiQ, Jazelle, Keil, Mali, Mbed, Mbed Enabled, NEON, POP, RealView, SecurCore, Socrates, Thumb, TrustZone, ULINK, ULINK2, ULINK-ME, ULINK-PLUS, ULINKpro, µVision, Versatile — are trademarks and/or registered trademarks of Arm Limited (or its subsidiaries or affiliates) in the US and/or elsewhere. The related technology may be protected by any or all of patents, copyrights, designs and trade secrets. All rights reserved.

DESFire — is a trademark of NXP B.V.

FeliCa — is a trademark of Sony Corporation.

ICODE and I-CODE — are trademarks of NXP B.V.

I2C-bus — logo is a trademark of NXP B.V.

MIFARE — is a trademark of NXP B.V.

MIFARE Classic — is a trademark of NXP B.V.

MIFARE Ultralight — is a trademark of NXP B.V.

Tables

Tab. 1.	Quick reference data	5	Tab. 26.	Operating conditions	44
Tab. 2.	Ordering information	7	Tab. 27.	Thermal characteristics	45
Tab. 3.	Marking codes	8	Tab. 28.	Thermal characteristics	45
Tab. 4.	WLCSP package marking (top view)	9	Tab. 29.	Current consumption characteristics for operating ambient temperature range	46
Tab. 5.	Pin description	11	Tab. 30.	Battery voltage monitor characteristics	46
Tab. 6.	WLCSP package marking (top view)	13	Tab. 31.	Reset timing	46
Tab. 7.	System power mode description	16	Tab. 32.	Power-up timings	46
Tab. 8.	System power modes configuration	17	Tab. 33.	Power-down timings	47
Tab. 9.	System power mode descriptions	17	Tab. 34.	High-speed mode I2C-bus timings specification	47
Tab. 10.	PN7150 power states	18	Tab. 35.	Fast mode I2C-bus timings specification	48
Tab. 11.	Functional modes in active state	19	Tab. 36.	Input clock characteristics on NFC_CLK_ XTAL1 when using PLL	49
Tab. 12.	Functionality for I2C-bus interface	22	Tab. 37.	Pin characteristics for NFC_CLK_XTAL1 when PLL input	49
Tab. 13.	I2C-bus interface addressing	22	Tab. 38.	Pin characteristics for 27.12 MHz crystal oscillator	49
Tab. 14.	Crystal requirements	23	Tab. 39.	PLL accuracy	49
Tab. 15.	PLL input requirements	24	Tab. 40.	VEN input pin characteristics	50
Tab. 16.	Communication overview for ISO/IEC 14443 type A and read/write mode for MIFARE Classic	34	Tab. 41.	pin characteristics for IRQ and CLK_REQ	50
Tab. 17.	Overview for FeliCa Reader/ Writer communication mode	35	Tab. 42.	Input pin characteristics for RXN and RXP	51
Tab. 18.	Overview for ISO/IEC 14443B Reader/ Writer communication mode	36	Tab. 43.	Output pin characteristics for TX1 and TX2	52
Tab. 19.	Communication overview for NFC forum T5T R/W mode	37	Tab. 44.	Output resistance for TX1 and TX2	52
Tab. 20.	Overview for Active communication mode	39	Tab. 45.	Input pin characteristics for I2CADR0 and I2CADR1	52
Tab. 21.	Overview for passive communication mode	40	Tab. 46.	Pin characteristics for I2CSDA and I2CSCL	53
Tab. 22.	Overview for NFC forum T4T, ISO/IEC 14443A card mode	41	Tab. 47.	Electrical characteristic of VDD	53
Tab. 23.	Overview for NFC forum T4T, ISO/IEC 14443B card mode	42	Tab. 48.	SnPb eutectic process (from J-STD-020D)	57
Tab. 24.	Overview for NFC forum T3T, Sony FeliCa card mode	42	Tab. 49.	Lead-free process (from J-STD-020D)	57
Tab. 25.	Limiting values	43	Tab. 50.	Abbreviations	59
			Tab. 51.	Revision history	62

Figures

Fig. 1.	PN7150 transmission modes	2	Fig. 20.	Battery voltage monitor principle	29
Fig. 2.	PN7150 package marking HVQFN40 (top view) 4 lines	8	Fig. 21.	Resetting PN7150 via VEN pin	30
Fig. 3.	PN7150 package marking HVQFN40 (top view) 3 lines	8	Fig. 22.	VBAT is set up before VDD(PAD)	31
Fig. 4.	PN7150 package marking WLCSP42 (top view)	9	Fig. 23.	VDD(PAD) and VBAT are set up at the same time	31
Fig. 5.	PN7150 block diagram	10	Fig. 24.	VDD(PAD) is set up or cut-off after PN7150 has been enabled	32
Fig. 6.	Pinning	11	Fig. 25.	Power-down sequence	32
Fig. 7.	WLCSP42 pinning (bottom view)	13	Fig. 26.	Read/write mode for ISO/IEC 14443 type A and read/write mode for MIFARE Classic	34
Fig. 8.	PN7150 connection	15	Fig. 27.	FeliCa Reader/Writer communication mode diagram	35
Fig. 9.	System power mode diagram	16	Fig. 28.	ISO/IEC 14443B Reader/Writer communication mode diagram	36
Fig. 10.	Polling loop: all phases enabled	20	Fig. 29.	R/W mode for NFC forum T5T communication diagram	37
Fig. 11.	Polling loop: low-power RF polling	21	Fig. 30.	FNFCIP-1 communication mode	38
Fig. 12.	27.12 MHz crystal oscillator connection	23	Fig. 31.	Active communication mode	39
Fig. 13.	Input reference phase noise characteristics	24	Fig. 32.	Passive communication mode	40
Fig. 14.	PMU functional diagram	25	Fig. 33.	I2C-bus timings	47
Fig. 15.	VBAT1 = VBAT2 (between 2.3 V and 5.5 V)	26	Fig. 34.	Package outline, HVQFN40, SOT618-1, MSL3	54
Fig. 16.	VDD(TX) offset behavior	27	Fig. 35.	Package outline, WLCSP42, SOT1459-1	55
Fig. 17.	VDD(TX) behavior when PN7150 is in Standby state	27	Fig. 36.	Temperature profiles for large and small components	58
Fig. 18.	VBAT1 = 5 V, VBAT2 between 2.3 V and 5.5 V	28			
Fig. 19.	VDD(TX) behavior when PN7150 is supply using external supply on VBAT1	28			

Contents

1	Introduction	1	12.7	Contactless interface unit	32
2	General description	2	12.7.1	Reader/Writer communication modes	33
3	Features and benefits	3	12.7.1.1	Communication mode for ISO/IEC 14443 type A, MIFARE Classic and Jewel/Topaz PCD	34
4	Applications	4	12.7.1.2	FeliCa PCD communication mode	35
5	Quick reference data	5	12.7.1.3	ISO/IEC 14443B PCD communication mode	36
6	Versions	6	12.7.1.4	R/W mode for NFC forum Type 5 Tag	37
6.1	Version C11006	6	12.7.2	ISO/IEC 18092, Ecma 340 NFCIP-1 communication modes	38
6.2	Version C11004	6	12.7.2.1	ACTIVE communication mode	39
6.3	Version C11002	6	12.7.2.2	Passive communication mode	40
7	Ordering information	7	12.7.2.3	NFCIP-1 framing and coding	41
8	Marking HVQFN40	8	12.7.2.4	NFCIP-1 protocol support	41
9	Marking WLCSP42	9	12.7.3	Card communication modes	41
10	Block diagram	10	12.7.3.1	NFC forum T4T, ISO/IEC 14443Acard mode	41
11	Pinning information	11	12.7.3.2	NFC forum T4T, ISO/IEC 14443B card mode	42
11.1	Pinning HVQFN40	11	12.7.3.3	NFC forum T3T, Sony FeliCa card mode	42
11.2	Pinning WLCSP42	13	12.7.4	Frequency interoperability	42
12	Functional description	15	13	Limiting values	43
12.1	System modes	16	14	Recommended operating conditions	44
12.1.1	System power modes	16	15	Thermal characteristics	45
12.1.2	PN7150 power states	18	15.1	Thermal characteristics HVQFN40	45
12.1.2.1	Monitor state	18	15.2	Thermal characteristics WLCSP42	45
12.1.2.2	Hard Power Down (HPD) state	18	16	Characteristics	46
12.1.2.3	Standby state	19	16.1	Current consumption characteristics	46
12.1.2.4	Active state	19	16.2	Functional block electrical characteristics	46
12.1.2.5	Polling loop	20	16.2.1	Battery voltage monitor characteristics	46
12.2	Microcontroller	21	16.2.2	Reset via VEN	46
12.3	Host interface	21	16.2.3	Power-up timings	46
12.3.1	I2C-bus interface	22	16.2.4	Power-down timings	47
12.3.1.1	I2C-bus configuration	22	16.2.5	I2C-bus timings	47
12.4	PN7150 clock concept	23	16.3	Pin characteristics	49
12.4.1	27.12 MHz quartz oscillator	23	16.3.1	NFC_CLK_XTAL1 and NFC_CLK_XTAL2 pins characteristics	49
12.4.2	Integrated PLL to make use of external clock	24	16.3.2	VEN input pin characteristics	50
12.4.3	Low-power 40 MHz ± 2.5 % oscillator	25	16.3.3	Pin characteristics for IRQ and CLK_REQ	50
12.4.4	Low-power 380 kHz oscillator	25	16.3.4	Input pin characteristics for RXN and RXP	51
12.5	Power concept	25	16.3.5	Output pin characteristics for TX1 and TX2	52
12.5.1	PMU functional description	25	16.3.6	Input pin characteristics for I2CADR0 and I2CADR1	52
12.5.2	DSLDO: dual supply LDO	26	16.3.7	Pin characteristics for I2CSDA and I2CSCL	53
12.5.3	TXLDO	26	16.3.8	VDD pin characteristic	53
12.5.3.1	Configuration 1: supply connection in case the battery is used to generate RF field	26	17	Package outline	54
12.5.3.2	Configuration 2: supply connection in case a 5 V supply is used to generate RF field with the use of TXLDO	28	17.1	Package outline HVQFN40	54
12.5.3.3	TXLDO limiter	28	17.2	Package outline WLCSP42	55
12.5.4	Battery voltage monitor	29	18	Soldering of SMD packages	56
12.6	Reset concept	30	18.1	Introduction to soldering	56
12.6.1	Resetting PN7150	30	18.2	Wave and reflow soldering	56
12.6.2	Power-up sequences	31	18.3	Wave soldering	56
12.6.2.1	VBAT is set up before VDD(PAD)	31	18.4	Reflow soldering	57
12.6.2.2	VDD(PAD) and VBAT are set up in the same time	31	19	Abbreviations	59
12.6.2.3	PN7150 has been enabled before VDD(PAD) is set up or before VDD(PAD) has been cut off	32	20	References	61
12.6.3	Power-down sequence	32			

High performance NFC controller with integrated firmware, supporting all NFC Forum modes

21 Revision history62
 Legal information64

Please be aware that important notices concerning this document and the product(s) described herein, have been included in section 'Legal information'.

© 2024 NXP B.V.

All rights reserved.

For more information, please visit: <https://www.nxp.com>

Date of release: 2 February 2024
Document identifier: PN7150

Looking for pricing, stock, or lifecycle information?

Click below to explore more details on WIN SOURCE:

- ⊖ [View PN7150B0HN/C11002E on WIN SOURCE](#)
- ⊖ [NXP / Nexperia Information](#)

Optimize Your Supply Chain with WIN SOURCE Solutions

- ✓ Global Sourcing Solution
- ✓ Obsolete Management
- ✓ Cost Control Management
- ✓ Shortage Management
- ✓ Alternative Solution
- ✓ Excess Inventory Management