



THE DATASHEET OF BNO080



The BNO08X family (BNO085/BNO086) is a System in Package (SiP) that integrates a triaxial accelerometer, triaxial gyroscope, magnetometer and a 32-bit ARM® Cortex™-M0+ microcontroller running CEVA's SH-2 firmware. The SH-2 includes the MotionEngine™ software, which provides sophisticated signal processing algorithms to process sensor data and provide precise real-time 3D orientation, heading, calibrated acceleration and calibrated angular velocity, as well as more advanced contextual outputs. The BNO08X is integrated into a single 28 pin LGA 3.8mm x 5.2mm x 1.1mm package. It is compatible with Android and provides a turn-key sensor hub solution, eliminating the complexity and investment associated with a discrete design.

The BNO08X features an enhanced sensor fusion algorithm which enables the use of add-on host-based software products for the AR/VR and other specialized markets. The BNO086 may be used as a drop-in replacement for the BNO085, with an identical pinout and software feature set. The BNO086 is a further enhancement over the BNO085 offering 14-bit accelerometer fusion, reduces idle state power and Interactive Calibration.

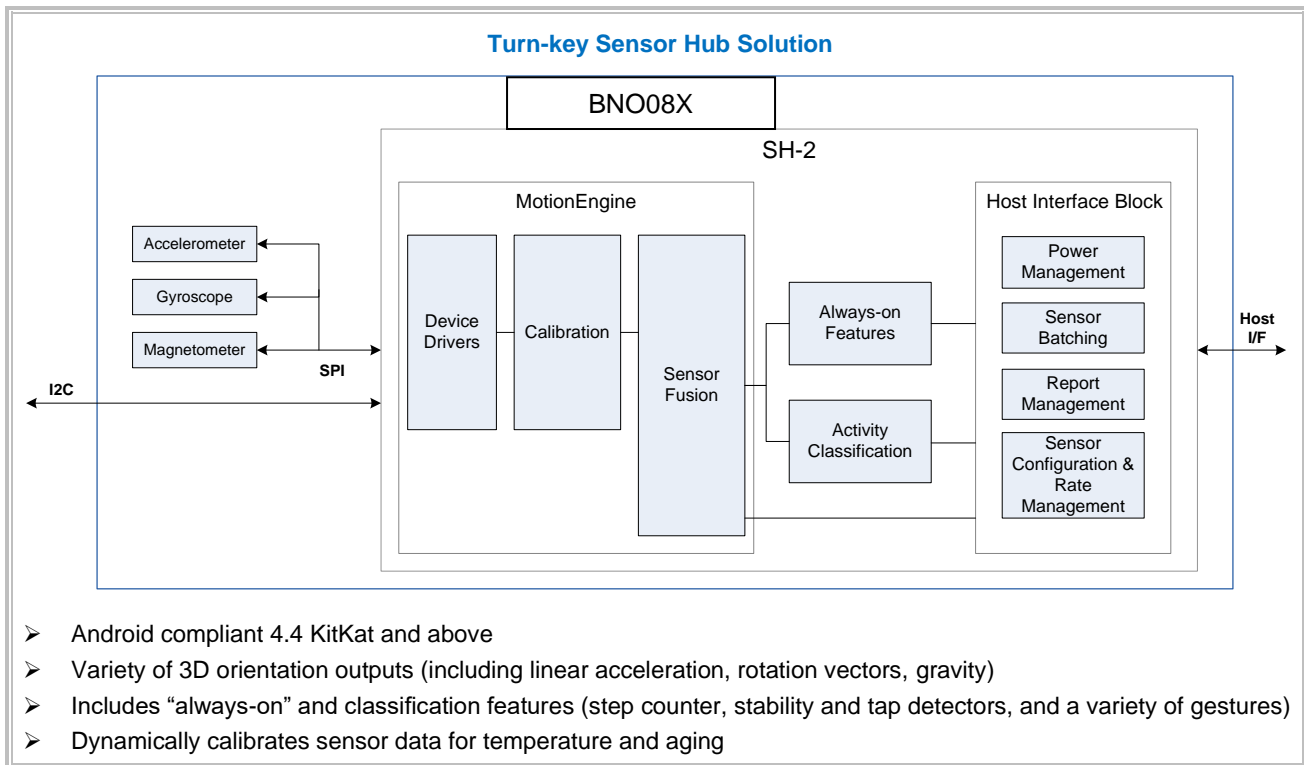

Sensor Hub Features

- Three sensors and microcontroller in a single device
- Supports new sensors and features in Android 4.4 KitKat
- Includes power management to optimize power
- Support for device firmware upgrade (DFU)

Extensive Data Modes

- Linear acceleration
- Angular velocity
- Angular position (quaternion)
- Data returned at configurable sample rates
- Timestamps attached to sensor reports
- AR/VR stabilization applied to rotation vectors provides visually improved angular position output
- Low latency, 1kHz gyro rotation vector for AR/VR applications

“Always-on” and Classification Features

- Built-in stability detector, tap detector, and step counter

Applications

- Wearables such as head trackers for AR/VR applications, smartwatches, fitness bands, audio headsets
- Smartphones
- Tablets
- Ultrabooks
- Robotics
- Internet of Things (IoT)

BNO085 and BNO086

- Enhanced sensor fusion algorithm to enable specialized CEVA host-based applications
- Optimized for use with virtual reality controller systems

BNO086 Only

- 14-bit accelerometer fusion
- Lower idle power
- Interactive Calibration

Table of Contents

LIST OF FIGURES	5
1 FUNCTIONAL OVERVIEW	7
1.1 Reference Design Configurations.....	8
1.1.1 Standalone Sensor Hub Solution in Mobile Devices	8
1.1.2 Virtual Reality Head Tracker	8
1.1.3 Unmanned Ground Roving Robot.....	9
1.2 BNO08X Connectivity	9
1.2.1 Pin Descriptions	10
1.2.2 I ² C interface.....	12
1.2.3 UART-SHTP interface.....	15
1.2.4 SPI Interface	17
1.2.5 UART-RVC interface.....	20
1.3 Host Communication	22
1.3.1 SHTP.....	22
1.3.2 Report Structure	23
1.3.3 BNO08X Configuration.....	24
1.3.4 Sensor Metadata	25
1.3.5 Sensor Reports	26
1.4 Bootloader	29
2 SENSOR DATA PROCESSING	30
2.1 Motion Outputs	30
2.1.1 Acceleration Outputs.....	30
2.1.2 Angular Velocity Outputs.....	31
2.1.3 Magnetometer Processing	31
2.2 Orientation Outputs.....	31
2.2.1 Geomagnetic Rotation Vector	31
2.2.2 Game Rotation Vector.....	31
2.2.3 AR/VR Stabilized Game Rotation vector	32
2.2.4 Rotation Vector	32
2.2.5 AR/VR Stabilized Rotation Vector.....	32
2.2.6 Gyro rotation Vector	32
2.2.7 Gyro rotation Vector Prediction	32
2.3 Environmental Sensors.....	33
2.4 Classification System.....	33
2.4.1 Stability Detection and Classification	33
2.4.2 Tap Detector	34
2.4.3 Step Detector	34
2.4.4 Step Counter	35
2.4.5 Activity Classification.....	35
2.4.6 Significant Motion Detector	36
2.4.7 Shake Detector	36
3 CALIBRATION AND INTERPRETATION	37
3.1 Calibration Effects.....	37
3.1.1 Calibration Command	37
3.1.2 Accelerometer	38
3.1.3 Gyroscope.....	38
3.1.4 Magnetometer	38
3.1.5 Calibration Accuracy	38

3.1.6	Recommended Settings	38
3.2	Calibration Steps	39
3.3	Interactive Calibration (BNO086 only)	39
3.4	Persist Dynamic Calibration Data	39
4	BNO08X ORIENTATION	40
4.1.1	Tare 42	
5	GETTING STARTED WITH BNO08X	43
5.1	BNO08X in UART-RVC mode	43
5.2	BNO08X in non UART-RVC configurations.....	43
5.2.1	Establishing Contact	43
5.2.2	Reading/Writing the BNO08X	43
6	BNO08X CHARACTERISTICS	45
6.1	Absolute Maximum Electrical Ratings	45
6.2	Recommended Operating Conditions	45
6.3	Power Management.....	45
6.4	Electrical Characteristics	46
6.5	AC Characteristics	46
6.5.1	I ² C Timing.....	46
6.5.2	SPI timing.....	46
6.5.3	Startup timing	47
6.5.4	Interrupt timing	48
6.6	Mechanical Characteristics.....	48
6.7	Performance Characteristics	49
6.8	Latency	49
6.9	Report Rates.....	50
6.10	Power Consumption	50
7	PACKAGING INFORMATION	53
7.1	Package Outline	53
7.2	Landing Pattern Recommendation	54
7.3	Soldering Guidelines.....	54
7.4	Marking	54
7.5	Soldering Guidelines.....	55
7.6	Handling Instructions	55
7.7	Environmental Safety.....	55
7.7.1	Halogen content	55
8	VERSION HISTORY	56
9	REFERENCES	58
10	NOTICES.....	59

List of Figures

Figure 1-1: BNO08X block diagram.....	7
Figure 1-2: BNO08X in a mobile device	8
Figure 1-3: Virtual reality head tracker	8
Figure 1-4: Typical unmanned ground roving robot	9
Figure 1-5: Protocol selection for BNO08X	9
Figure 1-6: BNO08X pin descriptions	10
Figure 1-7: 32.768kHz crystal connection	11
Figure 1-8: Clock Source Selection	11
Figure 1-9: External clock connection	11
Figure 1-10: Internal clock selection.....	12
Figure 1-11: BNO08X I ² C connection diagram.....	13
Figure 1-12: BNO08X I ² C address	14
Figure 1-13: I ² C START condition	14
Figure 1-14: I ² C STOP condition	14
Figure 1-15: Device addressing.....	15
Figure 1-16: I ² C write cycle.....	15
Figure 1-17: I ² C read cycle.....	15
Figure 1-18: BNO08X UART-SHTP connection diagram.....	16
Figure 1-19: UART signaling	17
Figure 1-20: BNO08X SPI connection diagram.....	18
Figure 1-21: BNO08X SPI signaling.....	19
Figure 1-22: SPI Wake operation	19
Figure 1-23: BNO08X UART-RVC connection diagram.....	20
Figure 1-24: UART signaling	21
Figure 1-25: BNO08X UART-RVC packet format	21
Figure 1-26: SHTP Header	22
Figure 1-27: SHTP executable commands and response.....	23
Figure 1-28: Product ID request	23
Figure 1-29: Product ID Response	24
Figure 1-30: BNO08X Commands.....	24
Figure 1-31: FRS records	25
Figure 1-32: BNO08X rotation vector metadata	25
Figure 1-33: Set Feature command.....	27
Figure 1-34: Calibrated gyroscope input report.....	28
Figure 1-35: Timebase Reference Report.....	28
Figure 1-36: Timestamping example	28
Figure 2-1: Android co-ordinate system	30
Figure 2-2: HMD mounted head motion prediction	33
Figure 2-3: Tap detector	34
Figure 2-4: Activity classification matrix.....	35
Figure 2-5: Shake gesture	36
Figure 3-1: Accuracy status of sensors	38
Figure 3-2: Calibration procedure for sensors	39
Figure 4-1: BNO08X axis orientation.....	40
Figure 4-2: BNO08X mounted in a device.....	41
Figure 4-3: Multiple 90 degree rotations.....	41
Figure 5-1: BNO08X set feature report (accelerometer) including SHTP header.....	44
Figure 5-2: Accelerometer & timebase input report including SHTP header	44
Figure 6-1: BNO08X maximum ratings.....	45
Figure 6-2: BNO08X operating conditions.....	45
Figure 6-3: BNO08X electrical characteristics.....	46
Figure 6-4: I ² C timing parameters	46
Figure 6-5: I ² C timing	46
Figure 6-6: SPI timing parameters.....	47
Figure 6-7: SPI timing.....	47

Figure 6-8: SPI timing parameters.....	47
Figure 6-9: Startup timing	47
Figure 6-10: Host interrupt timing – I ² C mode.....	48
Figure 6-11: Host interrupt timing - SPI mode.....	48
Figure 6-12: H_INTN timing.....	48
Figure 6-13: Host interrupt timing - UART-SHTP mode.....	48
Figure 6-14: BNO08X Performance	49
Figure 6-15: Typical latency measurements	50
Figure 6-16: Maximum sensor rates.....	50
Figure 6-17: Power consumption BNO085.....	51
Figure 6-18: Power consumption BNO086.....	52
Figure 7-1: 28 pin LGA package outline (Image from Bosch)	53
Figure 7-2: Landing pattern recommendation	54
Figure 7-3: Marking of mass production parts.....	55

1 Functional Overview

The BNO08X is manufactured by Bosch Sensortec and runs software provided by CEVA. The BNO08X integrates a triaxial 12-bit accelerometer with a range of $\pm 8g$, triaxial 16-bit gyroscope with a range of ± 2000 degrees per second, a triaxial geomagnetic sensor, and a 32-bit ARM® Cortex™-M0+ microcontroller. The sensors are provided by Bosch Sensortec GmbH and the Cortex M0+ processor by Atmel Corporation.

A system diagram of the BNO08X is shown in Figure 1-1.

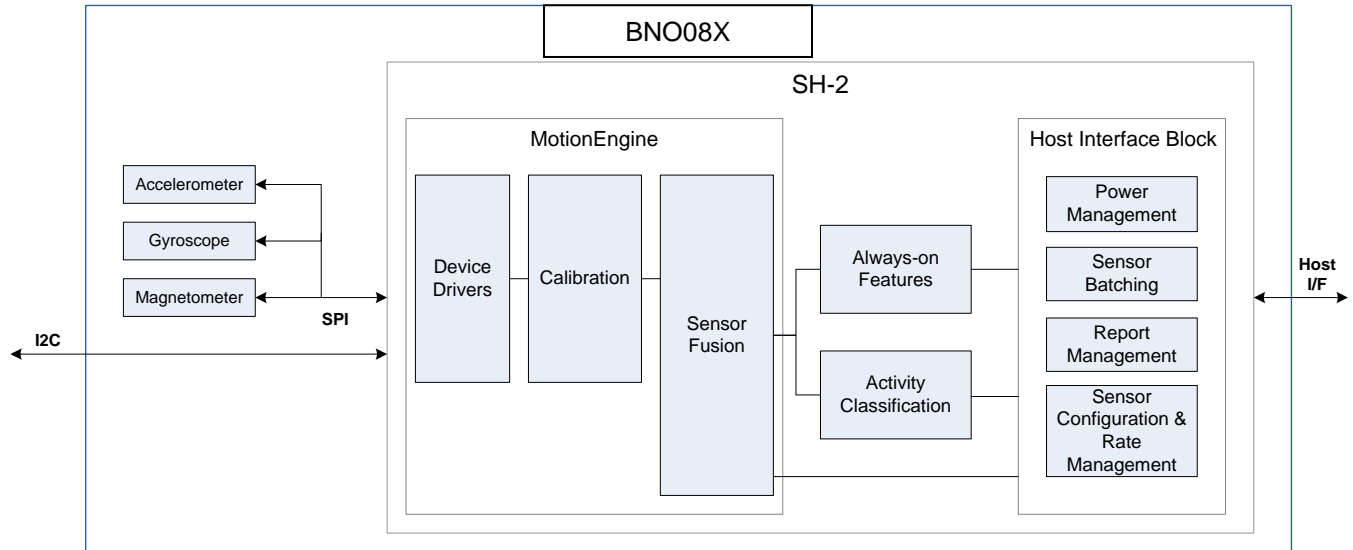

Figure 1-1: BNO08X block diagram

At the heart of the BNO08X is CEVA's SH-2 software. The SH-2 software includes MotionEngine™, 'always-on' features, activity classification and the host interface software. MotionEngine is digital signal processing software that takes raw motion data from the MEMS sensors and translates this data into precise motion information. These accurate motion outputs can be used for gesture detection and a variety of advanced motion-controlled applications. The 'always-on' and activity classification features include step counter, stability detector, tap detector, and gestures. The host interface module includes sophisticated power management functionality, configures sensors, and handles communication with the system host. The SH-2 supports sensor types defined in Android 4.4 KitKat. Android 5.0 defined additional methods of configuration which the BNO08X supports.

The BNO08X supports the addition of environmental sensors on a secondary I²C interface. See 2.3.

The BNO08X can communicate with the system host over various serial interfaces: SPI, I²C and UART.

1.1 Reference Design Configurations

1.1.1 Standalone Sensor Hub Solution in Mobile Devices

The BNO08X can be integrated as a co-processor in a mobile device such as a smartphone, tablet or ultrabook. This means the host processor can offload the sensor management and processing functions to the BNO08X. The BNO08X constantly processes sensor data in the background while the host processor is in sleep state and can provide the host processor with real-time sensor data on demand. This low power paradigm is useful to enable a number of 'always-on' applications such as activity tracking, gesture recognition, fitness and pedestrian dead reckoning.

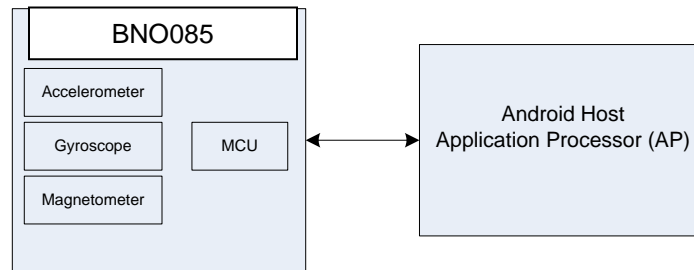

Figure 1-2: BNO08X in a mobile device

1.1.2 Virtual Reality Head Tracker

The BNO08X can be integrated into an HMD as a head tracker to allow the user to be immersed in either a virtual reality or an augmented reality application. The BNO08X provides accurate angular position data to allow navigation of this virtual world.

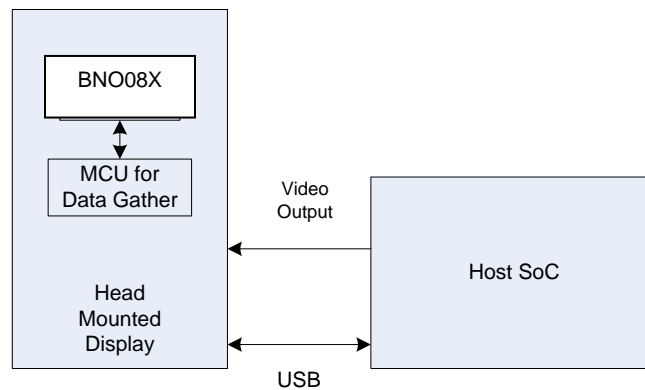

Figure 1-3: Virtual reality head tracker

1.1.3 Unmanned Ground Roving Robot

The BNO08X can be integrated into unmanned ground roving robot applications, providing heading information to fuse with cameras to allow navigation (SLAM – Simultaneous Localization and Mapping application). The BNO08X can also provide details on the tilt of the device and by virtue of the included accelerometer can serve as a bump detector.

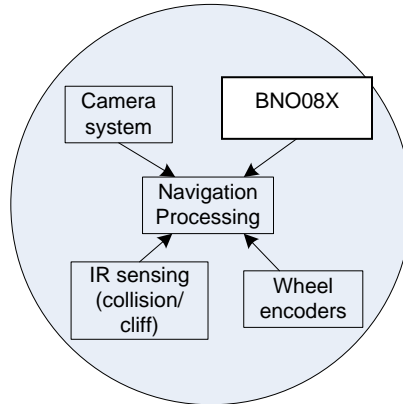

Figure 1-4: Typical unmanned ground roving robot

1.2 BNO08X Connectivity

The BNO08X can support connections to a host microcontroller through various serial interfaces:

- I²C interface
- UART interface
- SPI interface
- UART-RVC interface – a simplified UART interface for unmanned ground roving robot (such Robot Vacuum Cleaners)

In addition, the BNO08X includes a bootloader to allow for firmware upgrades. The bootloader can support I²C, SPI or UART. Access to the bootloader is achieved by setting BOOTN to 0.

Configuration of the communication interface is achieved by setting the protocol selection (PS1/0) pins appropriately:

PS1	PS0	BNO08X (BOOTN=1)	BNO08X bootloader (BOOTN=0)
0	0	I ² C	I ² C
0	1	UART-RVC	Reserved
1	0	UART	UART
1	1	SPI	SPI

Figure 1-5: Protocol selection for BNO08X

The protocol selection and BOOTN pins are sampled at reset.

PS0 is repurposed as a WAKE signal in SPI mode following reset (see 6.5.3 for timing).

1.2.1 Pin Descriptions

Figure 1-6 describes the function of each pin.

Pin Number	BNO08X Name	Mode	Description
1	RESV_NC	NC	Reserved. No connect.
2	GND	Input	Ground
3	VDD	Input	Supply voltage (sensors) (2.4V to 3.6V)
4	BOOTN	Input	Bootloader mode select
5	PS1	Input	Protocol Select pin 1
6	PS0/WAKE	Input	Protocol Select pin 0, also used to wake processor in SPI mode
7	RESV_NC	Input	Reserved. No connect.
8	RESV_NC	NC	Reserved. No connect.
9	CAP		External capacitor (100nF to GND)
10	CLKSEL0	Input	Clock source selection. Internal pulldown.
11	NRST	Input	Active low reset
12	RESV_NC	NC	Reserved. No connect.
13	RESV_NC	NC	Reserved. No connect.
14	H_INTN	Output	Interrupt to host device
15	ENV_SCL	Bidirectional	Environmental sensor I ² C clock
16	ENV_SDA	Bidirectional	Environmental sensor I ² C data
17	SA0/H_MOSI	Input	Lower address bit of device address. In SPI mode, data input
18	H_CSN	Input	SPI chip select, active low
19	H_SCL/SCK/RX	Bidirectional	Host Interface I ² C clock, SPI clock or UART RX
20	H_SDA/H_MISO/TX	Bidirectional	Host Interface I ² C data, SPI data out or UART TX
21	RESV_NC	NC	Reserved. No connect.
22	RESV_NC	NC	Reserved. No connect.
23	RESV_NC	NC	Reserved. No connect.
24	RESV_NC	NC	Reserved. No connect.
25	GND	Input	Ground
26	XOUT32/CLKSEL1	Output	32K crystal output / clock source selection. Internal pulldown.
27	XIN32	Input	32K crystal input. / external clock
28	VDDIO	Input	Supply voltage (core and I/O domain) (1.65V to 3.6V)

Figure 1-6: BNO08X pin descriptions

The BNO08X can operate from an internal oscillator, an external 32.768 kHz clock or an external 32.768 kHz crystal. If an external clock is used it must be connected to pin 27. CEVA recommends a tolerance of 50ppm. If a crystal is used it must be connected across pins 26 and 27. CEVA recommends using a crystal with tolerance 50ppm with 12.5pF capacitor loading.

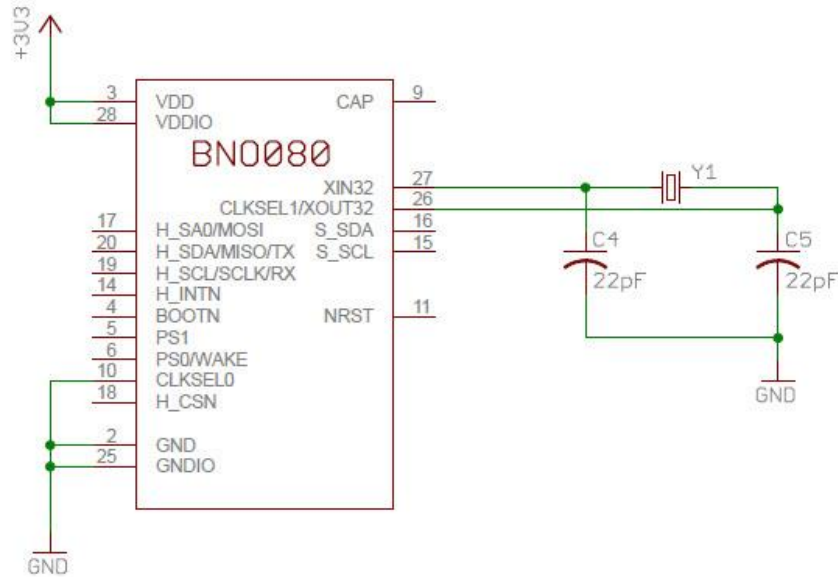

Figure 1-7: 32.768kHz crystal connection

Clock source selection is done during startup using the CLKSEL0 and CLKSEL1 pins. Figure 1-8 shows how to select each source. The internal clock source must not be used with the UART-SHTP or UART-RVC interfaces.

Source	CLKSEL0	CLKSEL1
Crystal	0 or unconnected	Connected to crystal
External	1	1
Internal	1	0 or unconnected

Figure 1-8: Clock Source Selection

CLKSEL0 is configured with an internal pulldown at startup. After CLKSEL0 has been sampled, if it is found to be a 1, the internal pulldown is disabled to avoid unnecessary power consumption. If either the external or internal clock sources are selected, then CLKSEL1 is configured as an input with a pulldown. CLKSEL1 is then sampled and the clock source determined. After CLKSEL1 has been sampled, if it is found to be a 1, the internal pulldown is disabled to avoid unnecessary power consumption.

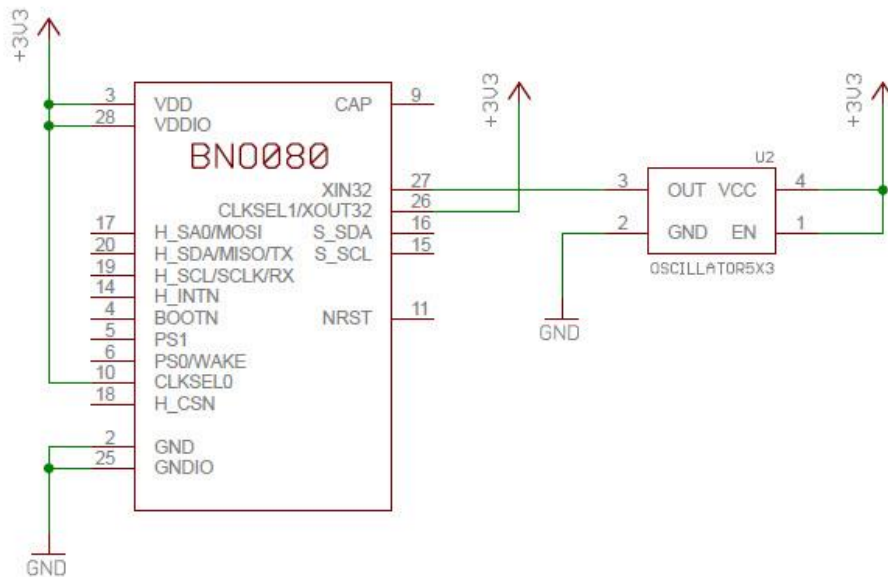

Figure 1-9: External clock connection

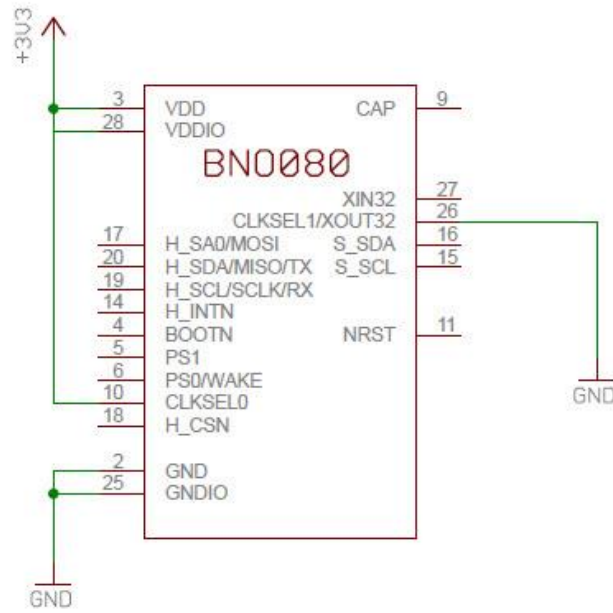

Figure 1-10: Internal clock selection

1.2.2 I²C interface

The BNO08X supports a standard Fast mode I²C interface and can communicate over this interface at up to 400kb/s.

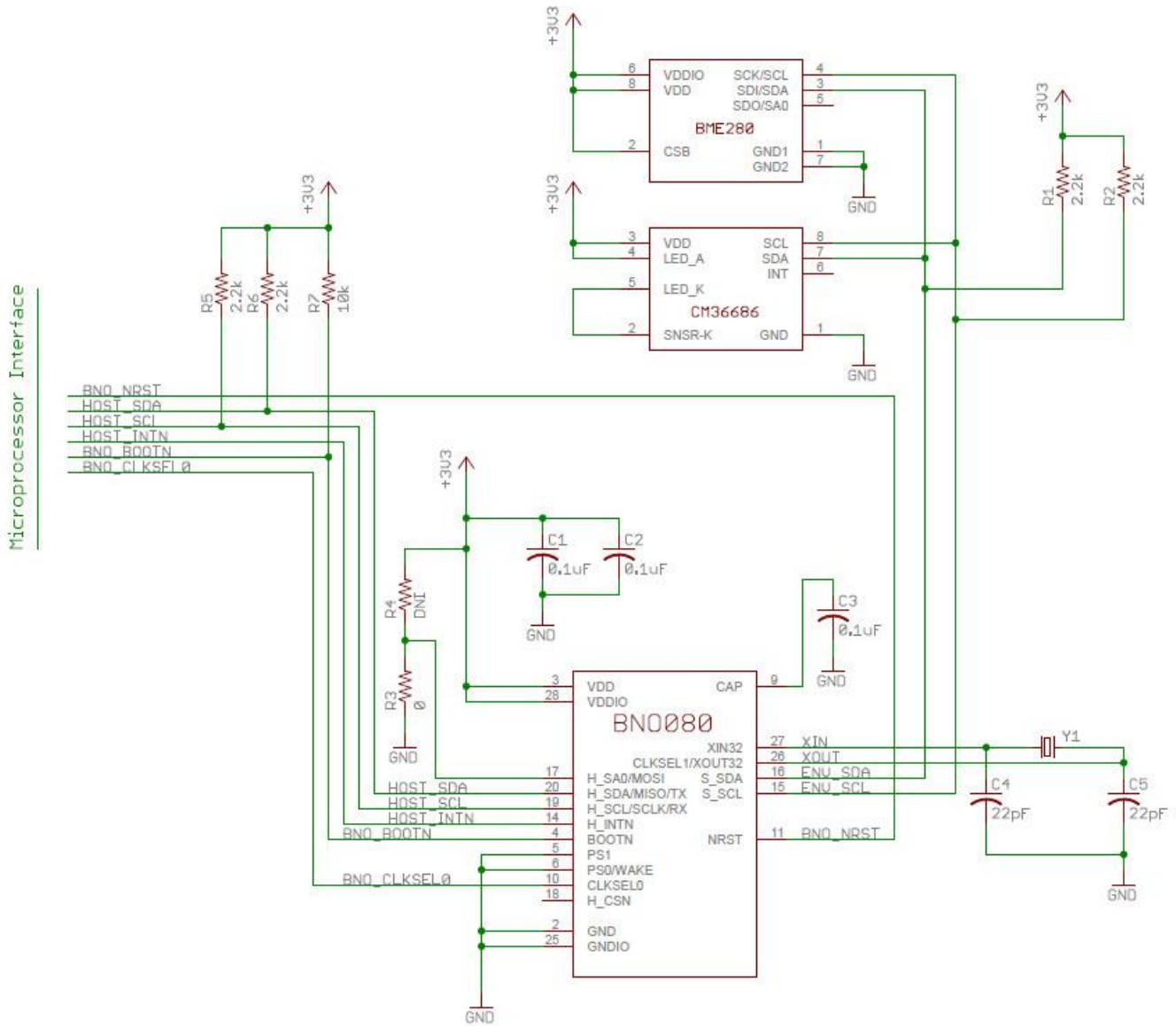

Figure 1-11: BNO08X I²C connection diagram

Figure 1-11 shows how the BNO08X can be connected to an external microcontroller via the I²C interface. The following notes are provided as guidelines for connecting the BNO08X in a system design.

1. The H_INTN pin is the application interrupt line that indicates the BNO08X requires attention. This should be tied to a GPIO with wake capability. The interrupt is active low.
2. NRST is the reset line for the BNO08X and can be either driven by the application processor or the board reset.
3. BOOTN is sampled at reset. If low the BNO08X will enter bootloader mode.
4. Pin 4 (BOOTN) should be pulled high through a 10K Ohms resistor. To use the device firmware update (DFU) capability of the BNO08X, it is recommended to connect Pin 4 to a GPIO pin on the external microcontroller.
5. Pin 5 (PS1) and Pin 6 (PS0/WAKE) are the host interface protocol selection pins. These pins should be tied to ground to select the I²C interface.
6. Pin 17 (SA0) can be used to select the lower bit of the 7-bit I²C slave device address.

7. Pullup resistors (R1 and R2) are needed on the I²C communication lines – Pin 19 (HOST_SCL) and Pin 20 (HOST_SDA). These values may vary depending on the board design and bus capacitance, but typical values are between 2K Ω and 4K Ω .
8. The BNO08X supports environmental sensors (e.g. pressure sensors, ambient light sensors) on a secondary I²C interface. This interface should be pulled up via resistors regardless of the presence of the external sensor as the SW polls for sensors at reset.

1.2.2.1 I²C Operation

The I²C specification is documented in [4]. The BNO08X provides a slave interface to the application processor and supports 100kbps Standard mode (Sm) and 400kbps Fast mode (Fm).

I²C is a two-wire serial interface that consists of a serial clock line (SCL) and a serial data line (SDA). I²C allows for multi-master, multi-slave communication and uses an open-drain architecture to enable this capability. All devices that drive the SDA line or SCL line can only drive the line low ('0'); the bus is released and pulled high by the pull-up resistor for '1's. The master device places the slave address on the data bus and the slave device with the corresponding address acknowledges the master.

The BNO08X I²C interface answers to a 7-bit address of either 0x4A or 0x4B:

6	5	4	3	2	1	0
1	0	0	1	0	1	SA0

Figure 1-12: BNO08X I²C address

The lower address bit of the device address is provided by the SA0 pin. This pin is sampled at reset and should be tied to either a logic high or logic low.

1.2.2.2 I²C Protocol

In general the data line should be stable while the clock is high, data transitions should therefore occur when the clock is low. Communication on an I²C bus is initiated with the master device presenting a START command and terminated with a STOP command. The bus is busy between the two commands. A START command (or condition) is defined as a transition on the SDA signal from high to low while the SCL signal is high (Figure 1-13). A STOP command (or condition) is defined as a low to high transition on the SDA signal while the SCL signal is high (Figure 1-14).

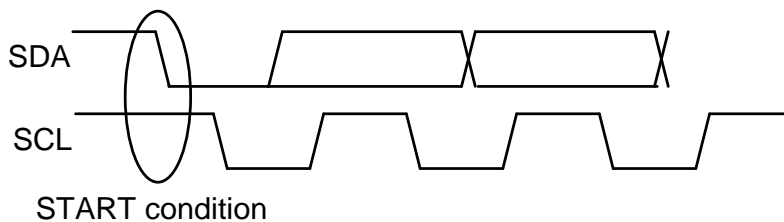

Figure 1-13: I²C START condition

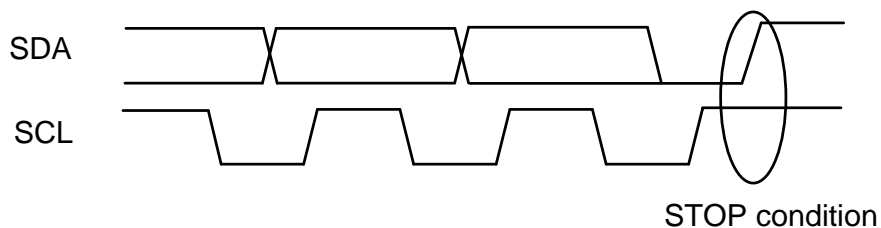

Figure 1-14: I²C STOP condition

I²C is a byte oriented protocol. Hence each element passed between the master and slave is 8-bits long. The bits within the byte are transmitted most-significant bit (MSB) first. For multi-byte words the data is presented in little-

endian format – least-significant byte first. The master device generates the clock. Every byte transmitted must be acknowledged. An acknowledgement is generated by the device receiving the data and is formed by the receiver driving the SDA line low during the ninth bit.

The master device generally drives the clock. However, if the slave device requires additional time to respond it can force the clock low, only releasing the line when it is prepared to deliver more data. The master device MUST support clock stretching.

The first byte presented after the start condition contains the device address and the read/write bit. The least-significant bit (LSB) of this first byte is the read/write indication ('0' corresponding to write)

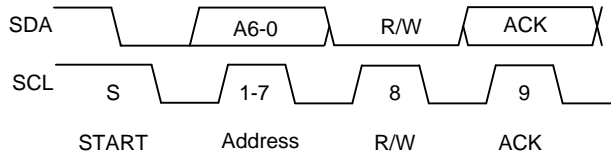

Figure 1-15: Device addressing

For a write cycle data is provided after the device address. The slave (BNO08X in this instance) provides an ACK for every byte received. A typical I²C write cycle is provided below (S=start, P=stop, AD=Address).



Figure 1-16: I²C write cycle

A read cycle requires that the device must first be selected with its device address. Following the device address the BNO08X will provide data. Every byte should be acknowledged by the master:

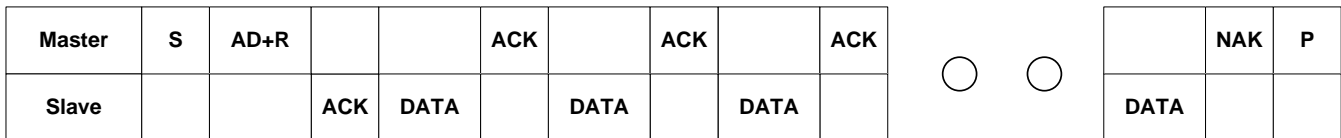

Figure 1-17: I²C read cycle

The BNO08X uses CEVA’s SHTP (Sensor Hub Transport Protocol) protocol to communicate. The BNO08X application does not support the repeated start method for typical I²C register based interfaces. More details are available in [2]. If the BNO085 is polled and it has no data to send it will stretch the clock until it has data to send. If the BNO086 is polled and it has no data to send, it will send zero data packets. Host should read the length field and ignore zero length packets.

1.2.3 UART-SHTP interface

The BNO08X provides a UART communication interface that supports CEVA’s SHTP protocol. The UART interface operates at 3Mb/s. A typical connection is shown in Figure 1-18. When using the UART interface either the external clock or crystal must be used. The internal clock is not accurate enough to operate the UART interface reliably.

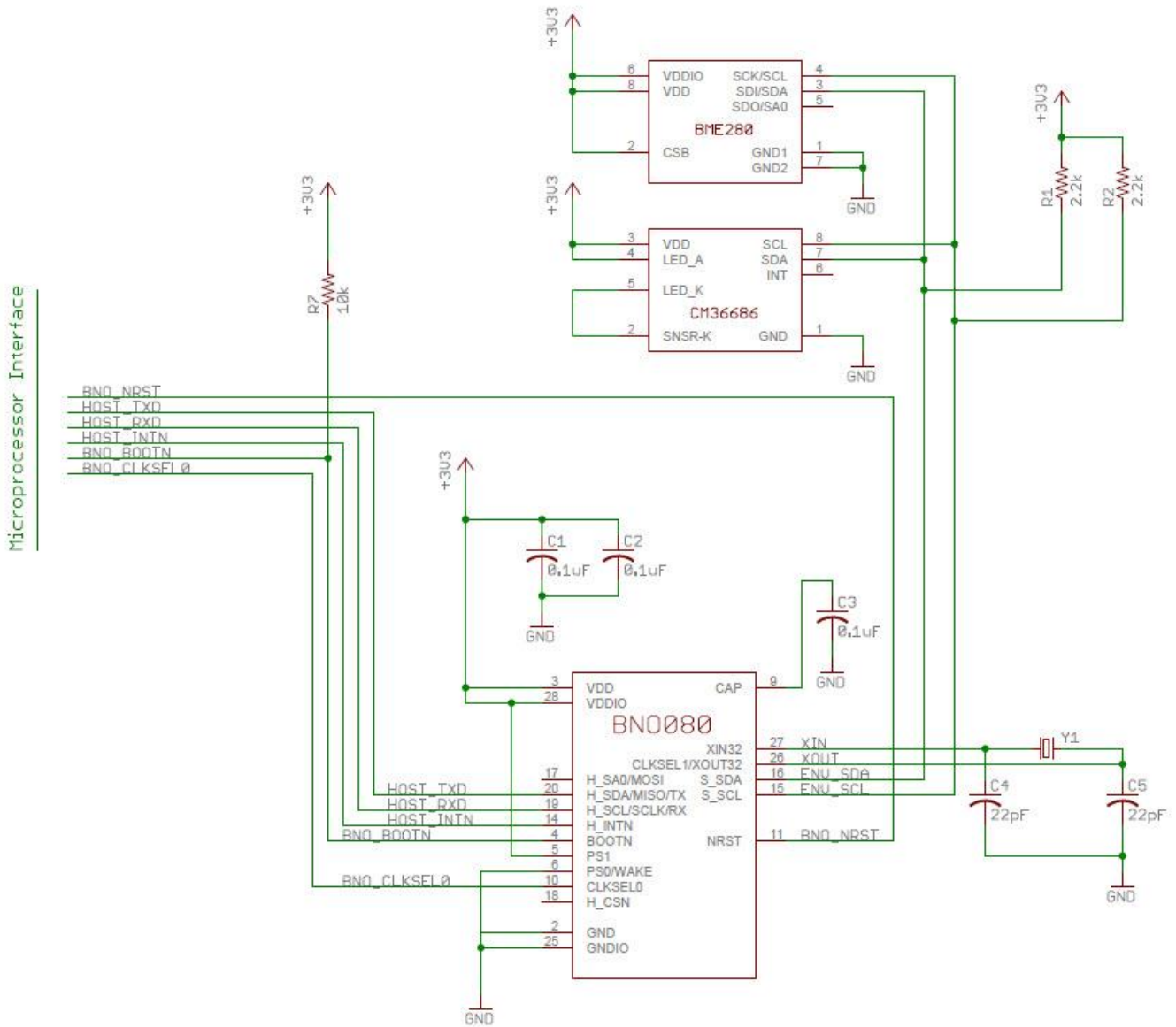

Figure 1-18: BNO08X UART-SHTP connection diagram

Figure 1-18 shows how the BNO08X can be connected to an external microcontroller via a UART interface. The following notes are provided as guidelines for connecting the BNO08X in a system design.

1. The H_INTN pin is driven low prior to the initial byte of UART transmission. It will deassert and reassert between messages. It is used by the host to timestamp the beginning of data transmission.
2. NRST is the reset line for the BNO08X and can be either driven by the application processor or the board reset.
3. BOOTN is sampled at reset. If low the BNO08X will enter bootloader mode.
4. Pin 4 (BOOTN) should be pulled high through a 10K Ohms resistor. To use the device firmware update (DFU) capability of the BNO08X, it is recommended to connect Pin 4 to a GPIO pin on the external microcontroller.
5. Pin 5 (PS1) and Pin 6 (PS0/WAKE) are the host interface protocol selection pins. These pins should be tied to VDDIO and ground respectively to select the UART-SHTP interface.

- The BNO08X supports environmental sensors (e.g. pressure sensors, ambient light sensors) on a secondary I²C interface. This interface should be pulled up via resistors regardless of the presence of the external sensor as the SW polls for sensors at reset.

1.2.3.1 UART operation

The UART is configured for 3Mkb/s, 8 data bits, 1 stop bit and no parity. The UART protocol relies on an idle line being 'high'. A transmission is started with the assertion of a start bit (pulling the line low), followed by the data, LSB first. After the data segment is sent (in this case 8-bits), the line is pulled high (the stop signal) for a minimum number of bits (1 for the BNO08X) to indicate end of that segment. Bytes sent from the host to the BNO08X must be separated by at least 100us. Bytes sent from the BNO to the host have no extra spacing.

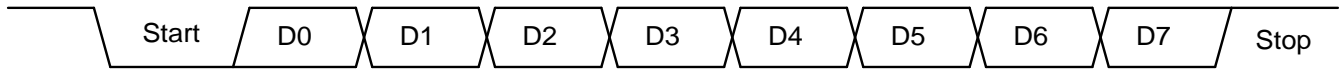

Figure 1-19: UART signaling

The BNO08X uses CEVA's SHTP protocol to communicate. The UART protocol makes use of framing bytes at the start and end of transmission. More details are available in [2].

1.2.4 SPI Interface

The BNO08X supports 4-wire Serial Peripheral Interface (SPI) for host communication. A typical connection diagram is provided in Figure 1-20.

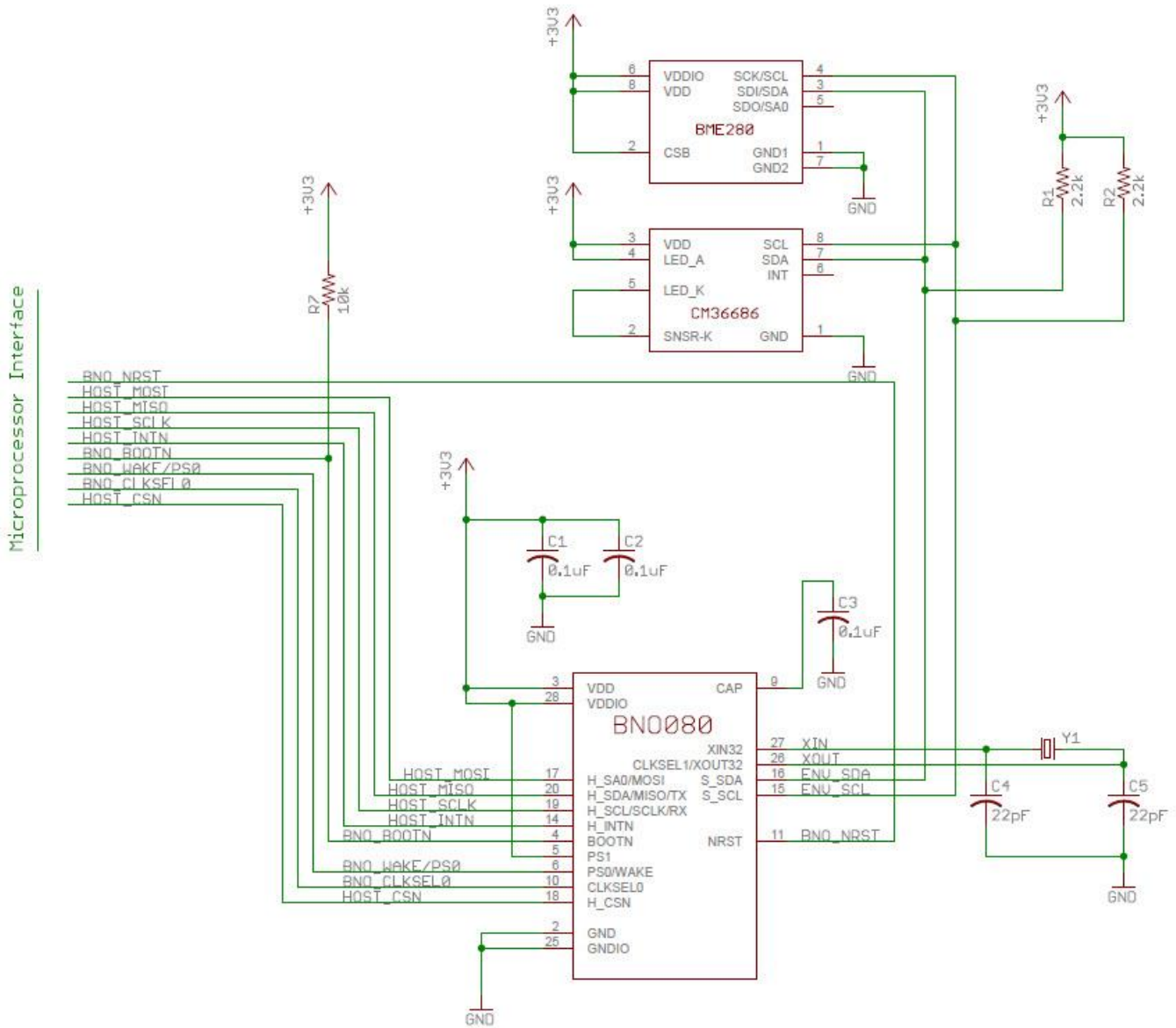

Figure 1-20: BNO08X SPI connection diagram

Figure 1-20 shows how the BNO08X can be connected to an external microcontroller via a SPI interface. The following notes are provided as guidelines for connecting the BNO08X in a system design.

1. The H_INTN pin is the application interrupt line that indicates the BNO08X requires attention. This should be tied to a GPIO with wake capability. The interrupt is active low.
2. NRST is the reset line for the BNO08X and can be either driven by the application processor or the board reset.
3. BOOTN is sampled at reset. If low the BNO08X will enter bootloader mode.
4. Pin 4 (BOOTN) should be pulled high through a 10K Ohms resistor. To use the device firmware update (DFU) capability of the BNO08X, it is recommended to connect Pin 4 to a GPIO pin on the external microcontroller.
5. Pin 5 (PS1) and Pin 6 (PS0/WAKE) are the host interface protocol selection pins. Both pins must be high from before reset until after the first assertion of H_INTN to select the SPI interface. Pin 5 may be tied to VDDIO. Pin 6 must be connected to a GPIO so that the WAKE functionality can be performed.

6. After reset the PS0/WAKE signal is used as a 'wake' signal taking the BNO08X out of sleep if the host wants to initiate communication with the BNO08X.
7. The BNO08X supports environmental sensors (e.g. pressure sensors, ambient light sensors) on a secondary I²C interface. This interface should be pulled up via resistors regardless of the presence of the external sensor as the SW polls for sensors at reset.

1.2.4.1 Responding to H_INTN

On the BNO085/BNO086, if the host fails to respond to the assertion of H_INTN within approximately 10 ms, the BNO085/BNO086 will timeout, deassert H_INTN and retry the operation. Delays in responding to H_INTN cause lost processing time on the BNO085/BNO086. Frequent delays will cause process starvation and some calculations will not be completed. The result is that some outputs will have errors. To avoid this problem H_INTN should be typically handled within 1/10 of the fastest sensor period.

1.2.4.2 SPI Operation

SPI is a 4-wire synchronous serial protocol. SPI provides a full duplex communication path and has a master/slave relationship. The master provides the clock for all transactions. Multiple slave devices can exist on a SPI interface by the use of a chip select signal. The BNO08X is the slave in all communications.

SPI allows for two clock polarities and clock edge sampling. These options are typically called CPOL and CPHA. The BNO08X uses CPOL = 1 and CPHA = 1. In this configuration the clock idles high and data is captured on the rising edge of the clock:

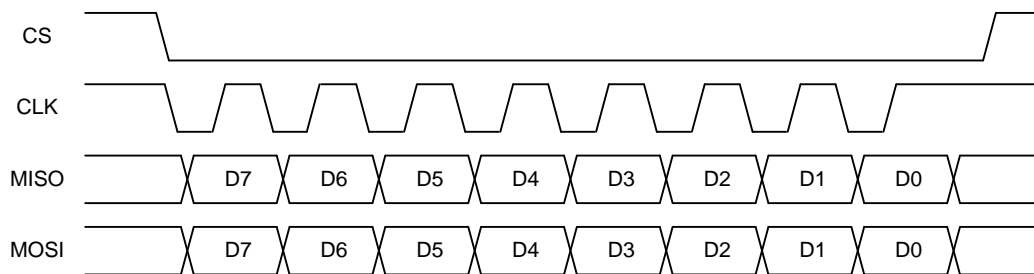

Figure 1-21: BNO08X SPI signaling

SPI transmits data MSB first and is byte oriented (i.e. all data is passed in 8-bit segments). Any number of bytes can be transferred in a single transaction (chip select assertion).

MISO is the data transferred from the slave to the master and MOSI from master to slave.

The BNO08X uses CEVA's SHTP protocol to communicate. More details are available at [2].

1.2.4.3 Wake operation

When the host want to initiate contact with the BNO08X it may be necessary to wake the processor from a sleep mode. To enable this function the BNO08X uses the PS0/wake pin. The pin is active low and should be driven low to initiate the wake procedure. The BNO08X will respond by asserting the interrupt line at which point the host can initiate SPI accesses. The BNO08X will de-assert the interrupt line as soon as the chip select is detected.

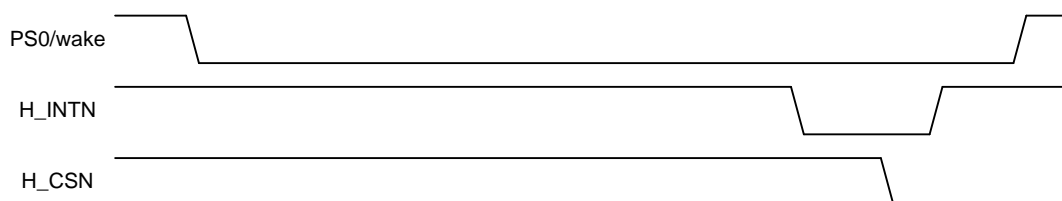

Figure 1-22: SPI Wake operation

1.2.5 UART-RVC interface

The BNO08X provides a simplified UART interface for use on unmanned ground roving robot such as robot vacuum cleaners (RVC). When configured in this mode the BNO08X simply transmits heading and sensor information at 100Hz over the UART TX pin. A typical connection is shown in Figure 1-23. When using the UART interface either the external clock or crystal must be used. The internal clock is not accurate enough to operate the UART interface reliably.

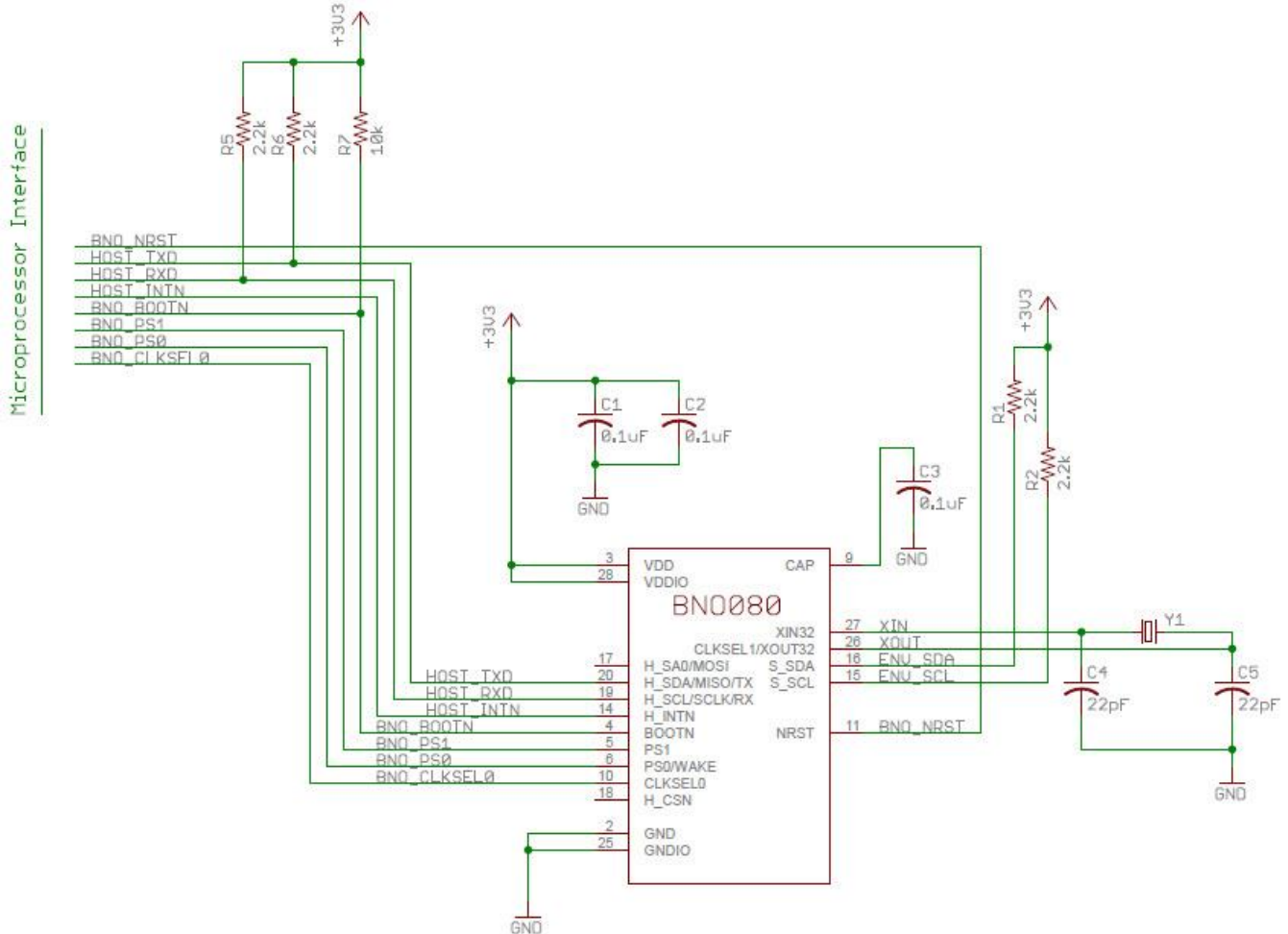

Figure 1-23: BNO08X UART-RVC connection diagram

Figure 1-23 shows how the BNO08X can be connected to an external microcontroller via a UART interface. The following notes are provided as guidelines for connecting the BNO08X in a system design.

1. NRST is the reset line for the BNO08X and can be either driven by the application processor or the board reset.
2. BOOTN is sampled at reset. If low the BNO08X will enter bootloader mode.
3. Pin 4 (BOOTN) should be pulled high through a 10K Ohms resistor. To use the device firmware update (DFU) capability of the BNO08X, it is recommended to connect Pin 4 to a GPIO pin on the external microcontroller.
4. Pin 5 (PS1) and Pin 6 (PS0) are the host interface protocol selection pins. These pins should be tied to ground and VDDIO respectively to select the UART-RVC interface.
5. The BNO08X supports environmental sensors (e.g. pressure sensors, ambient light sensors) on a secondary I²C interface. This interface should be pulled up via resistors regardless of the presence of the external sensor as the SW polls for sensors at reset.

1.2.5.1 UART-RVC operation

The UART operates at 115200 b/s, 8 data bits, 1 stop bit and no parity. The UART protocol relies on an idle line being 'high'. A transmission is started with the assertion of a start bit (pulling the line low), followed by the data, LSB first. After the data segment is sent (in this case 8-bits), the line is pulled high (the stop signal) for a minimum number of bits (1 for the BNO08X) to indicate end of that segment.

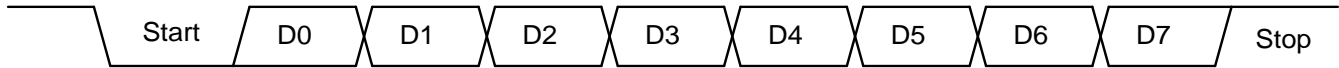

Figure 1-24: UART signaling

1.2.5.2 UART-RVC protocol

The BNO08X transmits the following data at a rate of 100Hz.

Header	Index	Yaw		Pitch		Roll		X-axis accel		Y-axis accel		Z-axis accel		MI	MR	Rsvd	Csum
0xAAAA		LSB	MSB	LSB	MSB	LSB	MSB	LSB	MSB	LSB	MSB	LSB	MSB				

Figure 1-25: BNO08X UART-RVC packet format

The 19-byte message has the following fields:

Header: Each report is prefixed with a 0xAAAA header

Index: A monotonically increasing 8-bit count is provided (0-255) per report

Yaw: The yaw is a measure of the rotation around the Z-axis since reset. The yaw has a range of +/- 180° and is provided in 0.01° increments, i.e. a report of 8734 is equivalent to 87.34°.

Pitch: The pitch is a measure of the rotation around the Y-axis. The pitch has a range of +/- 90° and is provided in 0.01° increments, i.e. a report of 1072 is equivalent to 10.72°.

Roll: The roll is a measure of the rotation around the X-axis. The roll has a range of +/- 180° and is provided in 0.01° increments, i.e. a report of 1072 is equivalent to 10.72°.

X-axis acceleration: The acceleration along the X-axis, presented in mg

Y-axis acceleration: The acceleration along the Y-axis, presented in mg

Z-axis acceleration: The acceleration along the Z-axis, presented in mg

MI – Motion Intent – BNO086 only. Otherwise, reserved

MR – Motion Request – BNO086 only. Otherwise, reserved.

Reserved: The message is terminated with one (BNO086) or three (otherwise) reserved bytes, currently set to zero

Checksum (Csum): The Index, yaw, pitch, roll, acceleration and reserved data bytes are added to produce the checksum.

To determine the actual orientation of the module, the rotations should be applied in the order yaw, pitch then roll.

An example complete message and checksum calculation is as follows:

Message: 0xAA AA DE 01 00 92 FF 25 08 8D FE EC FF D1 03 00 00 00 E7

Where:

Index = 0xDE = 222

Yaw = 00.01° (1 = 0x0001)

Pitch = -1.10° (-110 = 0xFF92)

Roll = 20.85° (2085 = 0x0825)

X-acceleration = -371 mg = -3.638 m/s² (-371 = 0xFE8D)

Y-acceleration = -20 mg = -0.196 m/s² (-20 = 0xFFEC)

Z-acceleration = 977 mg = 9.581 m/s² (977 = 0x03D1)
Checksum = 0xE7

1.3 Host Communication

1.3.1 SHTP

The BNO08X uses CEVA's SHTP (Sensor Hub Transport Protocol) to communicate for all interface styles except UART-RVC. SHTP provides a means of passing data between the BNO08X and a host with support for multiple channels. The BNO08X does not currently support the inclusion of 3rd party applications, but the SHTP protocol allows for separation of traffic via these channels such that applications on a host can communicate over this channel.

All data is prefixed with a 4-byte header:

Byte	Field
0	Length LSB
1	Length MSB
2	Channel
3	SeqNum

Figure 1-26: SHTP Header

Length	Bit 15 of the length field is used to indicate if a transfer is a continuation of a previous transfer. Bits 14:0 are used to indicate the total number of bytes in the cargo plus header, which may be spread over multiple messages. The bytes in the header field are counted as part of the length. A length of 65535 (0xFFFF) is reserved because a failed peripheral can too easily produce 0xFFFF. Therefore, the largest cargo that can be transported is 32766 minus the header bytes. The BNO08X does not support receiving fragmented messages but it does support sending them.
Channel	The channel number of the cargo. Channel 0 is the command channel and is used by the SHTP.
SeqNum	The sequence number of the cargo. The sequence number is a monotonically incrementing number that increments once for each cargo sent or cargo continuation sent. Each channel and each direction has its own sequence number. The sequence number is used to detect duplicate or missing cargoes and to associate segmented cargoes with each other.

The length field allows a host to schedule the correct number of clocks to generate for reads over I²C and SPI. The BNO08X supports partial reads if the host cannot accept all the bytes in one read, the length will be updated on a subsequent read. So, for instance a host could read the first 4 bytes to determine the number of clocks to generate and then repeat the read with the required number of clocks. The protocol is fully described in [2].

The BNO08X supports 6 channels:

- Channel 0: the SHTP command channel
- Channel 1: executable
- Channel 2: sensor hub control channel
- Channel 3: input sensor reports (non-wake, not gyroRV)
- Channel 4: wake input sensor reports (for sensors configured as wake up sensors)
- Channel 5: gyro rotation vector

The SHTP control channel provides information about the applications built into the BNO08X firmware image. The BNO08X uses advertisements to publish the channel maps and the names of the built-in applications.

The executable channel allows the host to reset the BNO08X and provide details of its operating mode. Figure 1-27 provides details.

:

SHTP Channel	Use	Direction
1 (executable)	0 – reserved 1 – reset 2 – on 3 – sleep 4-255 – reserved	Write
	0 – reserved 1 – reset complete 2-255 – reserved	Read

Figure 1-27: SHTP executable commands and response

The use of the 'on' and 'sleep' commands provides support when the host is entering and exiting sleep. When the 'sleep' command is issued all sensors that are configured as always on or wake (see 1.3.5.1) will continue to operate all, other sensors will be disabled. All configured sensors will be enabled when the host issues the 'on' command.

The sensor hub control channel is used to configure the BNO08X. Responses from the BNO08X in reaction to configuration requests are also sent over this channel.

The input sensor report channel is unidirectional, passing data from the BNO08X to the host. All input reports pass over this channel except for sensors that are configured as wake sensors and the gyro rotation vector. A wake sensor is defined in Android as a sensor that will remain awake during periods when a mobile device is asleep and can wake the processor when a particular event occurs (the event being defined by the sensor).

The wake input sensor report channel is used for sensors that are configured as wake sensors.

The gyro rotation vector is a channel used for the gyro rotation vector. A separate channel is provided to allow applications on a host processor to prioritize this data over others to ensure low latency.

1.3.2 Report Structure

The BNO08X runs CEVA's SH2 protocol. Full details are available in [1].

All commands, responses, sensor input reports are prefixed with a report number. The report number follows the SHTP header.

For example, the command to read the Product ID is:

Byte	Description
0	Report ID = 0xF9
1	Reserved

Figure 1-28: Product ID request

The BNO08X will respond to the Product ID request with the following response:

Byte	Description
0	Report ID = 0xF8
1	Reset Cause
2	SW Version Major
3	SW Version Minor
4	SW Part Number LSB
5	SW Part Number ...
6	SW Part Number ...

Byte	Description
7	SW Part Number MSB
8	SW Build Number LSB
9	SW Build Number ...
10	SW Build Number ...
11	SW Build Number MSB
12	SW Version Patch LSB
13	SW Version Patch MSB
14	Reserved
15	Reserved

Figure 1-29: Product ID Response

The list of currently supported commands/configurations is:

SHTP Channel	Direction	Report ID	Description
2 (SH-2 control)	Host to BNO	0xFE	Get Feature Request
2 (SH-2 control)	Host to BNO	0xFD	Set Feature Command
2 (SH-2 control)	BNO to host	0xFC	Get Feature Response
2 (SH-2 control)	Host to BNO	0xF9	Product ID Request
2 (SH-2 control)	BNO to host	0xF8	Product ID Response
2 (SH-2 control)	Host to BNO	0xF7	FRS Write Request
2 (SH-2 control)	Host to BNO	0xF6	FRS Write Data
2 (SH-2 control)	BNO to Host	0xF5	FRS Write Response
2 (SH-2 control)	Host to BNO	0xF4	FRS Read Request
2 (SH-2 control)	BNO to host	0xF3	FRS Read Response
2 (SH-2 control)	Host to BNO	0xF2	Command Request
2 (SH-2 control)	BNO to host	0xF1	Command Response

Figure 1-30: BNO08X Commands

1.3.3 BNO08X Configuration

Motion analysis systems must process data from sensors that can be mounted in an arbitrary manner and in systems with characteristics that affect the way the data is delivered. For example a tap detector could behave differently in a small form factor device made of metal than a tap detector in a larger form factor device made of plastic. Another example is the static calibration record. This record provides a description of the sensor and its orientation; necessary details to provide calibration of the sensor data.

The BNO08X contains a Flash Record System (FRS) to store these configurations.

Complete documentation of these records is provided in [1]. Supported FRS records in the BNO08X are:

Record ID	Description
0x7979	Static calibration – AGM
0x4D4D	Nominal calibration – AGM
0x8A8A	Static calibration – SRA
0x4E4E	Nominal calibration - SRA
0x1F1F	Dynamic calibration
0xD3E2	MotionEngine power management
0x2D3E	System orientation
0x2D41	Primary accelerometer orientation
0x2D46	Gyroscope orientation
0x2D4C	Magnetometer orientation
0x3E2D	AR/VR stabilization – rotation vector

Record ID	Description
0x3E2E	AR/VR stabilization – game rotation vector
0xC274	Significant Motion detector configuration
0x7D7D	Shake detector configuration
0xD7D7	Maximum fusion period
0x4B4B	Serial number
0x39AF	Environmental sensor - Pressure calibration
0x4D20	Environmental sensor - Temperature calibration
0x1AC9	Environmental sensor - Humidity calibration
0x39B1	Environmental sensor - Ambient light calibration
0x4DA2	Environmental sensor - Proximity calibration
0xD401	ALS Calibration
0xD402	Proximity Sensor Calibration
0xED85	Stability detector configuration
0x74B4	User record
0xD403	MotionEngine Time Source Selection
0xA1A2	Gyro-Integrated Rotation Vector configuration

Figure 1-31: FRS records

FRS records are written by use of FRS read and write requests. Writing and reading FRS records follows a multi-step protocol.

For writes an FRS Write Request is issued indicating which FRS record to write and the amount of data to be written. The BNO08X will respond with a write response acknowledging the request. The host will then issue a number of FRS Write Data packets to which the BNO08X will respond. The final response from the BNO08X will indicate a successful conclusion to the flash writes or if the process failed a failure indication.

An FRS read follows a similar pattern. An FRS Read request is issued and FRS Read responses provide the data with the final response indicating completion of the record retrieval.

1.3.4 Sensor Metadata

The BNO08X operates as a sensor hub and as such provides processing of sensor data. In order for a user to understand the capabilities of the sensors, metadata is provided that describes those capabilities. The SH-2 reference manual provides full details of the metadata record but as an example Figure 1-32 provides the metadata for the rotation vector. Metadata is stored as an FRS record and is therefore retrieved as an FRS read.

Word	Description	
	MSB	LSB
0	Version = 0x00010001	
1	Range = 1.0	
2	Resolution = 6.103515625e-05	
3	Revision = 4	Power = 5.3017578125
4	Minimum period = 1000	
5	FIFO reserved count = 1	FIFO max count = 0
6	Vendor ID length = 0	Batch buffer bytes = 14
7	Q point 2 = 12	Q point 1 = 14
8	Q point 3 = 13	Sensor-Specific Metadata Length = 0
9	Maximum period = 10000	
10	Sensor-Specific metadata = 0	
N	Vendor ID	

Figure 1-32: BNO08X rotation vector metadata

Version	Identifies the physical sensor/driver/fusion versions for a given sensor. The elements within this field are updated when a component changes in a manner that affects the output of the sensor. LSB – ME version Byte 1 – MH version Byte 2 – SH version MSB – 0x00
Range	The range of the sensor. The format is unsigned fixed point. The units and Q point are the same as those used in the sensor's input report.
Resolution	The resolution of the sensor. The format is unsigned fixed point. The units and Q point are the same as those used in the sensor's input report.
Power	The power used by the sensor in mA when operating. The format is unsigned fixed point. The Q point is 10.
Revision	Indicates the revision of the metadata record.
Minimum period	An unsigned integer indicating the minimum operating period in microseconds of the sensor.
FIFO max count	The maximum number of samples that can be stored in the batch buffer.
FIFO reserved count	The number entries reserved in the batch FIFO for this sensor
Batch buffer bytes	The number of bytes used in the batch buffer to store one entry.
Vendor ID length	The length of the vendor ID in bytes.
Q point 1	A signed 16-bit integer indicating the Q point of the sensor data fields.
Q point 2	A signed 16-bit integer indicating the Q point of the sensor bias or accuracy fields. This field is applicable only to sensors that have bias or accuracy outputs as well as data outputs.
Sensor-Specific Metadata length	An unsigned 16-bit integer indicating how many bytes are used for sensor-specific metadata. 0 if there is no additional metadata. This value must be a multiple of four.
Q point 3	A signed 16-bit integer indicating the Q point of the sensor data change sensitivity.
Maximum period	An unsigned integer indicating the maximum operating period in microseconds of the sensor.
Sensor specific metadata	Some sensors provide additional metadata (see [1])
Vendor ID	A null terminated string describing the vendor name and part number.

1.3.5 Sensor Reports

Sensors are enabled by the host issuing a Set Feature command, the feature report ID being for the sensor of interest. The Set Feature command provides the parameters necessary for the sensor to be enabled. Typically this is just the sampling period (report interval), but some sensors require additional configuration. A sensor can be configured to only issue reports when a change in the sensor value occurs (change sensitivity), this can be absolute or relative. An absolute change is a change from below to above a certain value, while relative is a

change between two consecutive samples. Google introduced the concept of batching which is supported by the BNO08X with a batch interval field.

Byte	Description
0	Report ID = 0xFD
1	Feature Report ID
2	Feature flags
3	Change sensitivity [absolute relative] LSB
4	Change sensitivity [absolute relative] MSB
5	Report Interval LSB
6	Report Interval
7	Report Interval
8	Report Interval MSB
9	Batch Interval LSB
10	Batch Interval
11	Batch Interval
12	Batch Interval MSB
13	Sensor-specific configuration word LSB
14	Sensor-specific configuration word
15	Sensor-specific configuration word
16	Sensor-specific configuration word MSB

Figure 1-33: Set Feature command

The host can request a feature report for a particular sensor (Get Feature command) to which the BNO08X will respond with a Get Feature Response. This can be used to verify the configuration of a sensor. A Get Feature Response is also issued by the BNO08X whenever the sensor's operating mode changes which can occur due to the host issuing a Set Feature command or because the internal rates changed due to events within the BNO08X.

1.3.5.1 Batching

Batching is a power management feature added to Android Lollipop. The concept is that the application processor receives data in batches hence avoiding the constant processing of sensor data. This delay in processing allows the processor to do more useful work until sufficient sensor data has accumulated for the task for which the sensor data was requested. In addition when the application processor sleeps, sensor data can accumulate in a batch buffer and be used to wake the processor when sufficient data has accumulated.

To facilitate the batching the BNO08X provides two batch queues. The higher priority queue is for wake sensors and the other for all remaining enabled sensors (described as always-on in [1]). The batch interval in the set feature command indicates how many microseconds must pass before the batch is sent to the host. If the application processor is asleep it will be woken when the wake queue reaches the programmed interval. At that point all data from both queues will be pushed to the host. Data in the non-wake queue will be allowed to be lost, oldest data first in the event the application processor is sleeping. A sensor is designated as a wake sensor by a flag in the feature flags field.

Note that the BNO08X only supports one batch queue per type of sensor. If a sensor is configured as a wake sensor it cannot also be marked as a non-wake sensor (always-on).

1.3.5.2 Example sensor report

All input reports have a similar format ([1] provides full details). The calibrated gyroscope output is an example:

Byte	Description
0	Report ID = 0x02
1	Sequence number
2	Status
3	Delay

Byte	Description
4	Gyroscope calibrated Axis X LSB
5	Gyroscope calibrated Axis X MSB
6	Gyroscope calibrated Axis Y LSB
7	Gyroscope calibrated Axis Y MSB
8	Gyroscope calibrated Axis Z LSB
9	Gyroscope calibrated Axis Z MSB

Figure 1-34: Calibrated gyroscope input report

The sequence number is a monotonically increasing value that is used to check for dropped samples.

The status byte is broken into two fields:

Bits 1:0 – indicate the status of a sensor.

- 0 – Unreliable
- 1 – Accuracy low
- 2 – Accuracy medium
- 3 – Accuracy high

Bits 7:2 - Delay upper bits: 6 most-significant bits of report delay

The delay byte is the lower 8 bits of the report delay. Delay has a resolution of 100µs.

Bytes 4-9 of the report provide the gyroscope data.

1.3.5.3 Timestamping

The sensor report delay field allows an accurate timestamp to be formed in the host application. Delay measures the time delta from the sensor interrupt to the timebase reference. By generating a timestamp on the host interrupt signal the host application can then determine an accurate sensor timestamp by subtracting delay.

Note that the BNO08X also provides a timebase reference report with sensor reports:

Byte	Description
0	Report ID=0xFB
1	Base Delta LSB: relative to transport-defined reference point. Signed. Units are 100 microsecond ticks.
2	Base Delta
3	Base Delta
4	Base Delta MSB

Figure 1-35: Timebase Reference Report

The timebase reference functions in the same way as the delay field in the sensor report. The base delta should be subtracted from the timestamp registered on the host for the host interrupt signal. When the timebase reference report is provided the individual sensor report will likely have a delay of zero. However, in cases where sensor reports are concatenated (due to delays in processing), the delay field may be populated, in which case both that delay and the timebase reference should be taken into account when calculating the actual timestamp of the sensor sample.

As an example, if the host receives the following report:

Timebase Reference Delta = 120	Sensor report Delay = 0	Sensor report Delay = 17
--------------------------------	-------------------------	--------------------------

Figure 1-36: Timestamping example

The host will create a timestamp based on the assertion of HINT (call it T). The timebase reference provides a baseline reference of $120 * 100\mu\text{s}$ or 12ms. All sensor reports are thus timestamped as T-12ms + their own delay.

In this example, the first sensor report should be timestamped as occurring at T-12ms and the second at T – 10.3ms (T - 12ms + 1.7ms).

1.4 Bootloader

The BNO08X provides a bootloader function to allow firmware upgrades to be applied. During reset or power-on sequence, the bootloader first checks the status of the BOOTN pin. If the pin is pulled low during reset or power-on, the BNO08X will enter the bootloader mode. If the BOOTN pin is pulled high, then the bootloader starts the application.

The bootloader uses the host interface as configured by the PS0/1 pins (see Figure 1-5). If I²C is selected the bootloader has an I²C address of either 0x28 or 0x29 (SA0 provides the lowest address bit).

After the BNO08X enters the bootloader mode, it waits for the size of the application code from the host. The application to be written to flash is split into a number of frames. The application in flash is updated by writing these frames to the BNO08X and reading a status back to verify the write was successful.

Reference code (on the host microcontroller) for using the bootloader to perform Device Firmware Upgrade (DFU) is available upon request.

2 Sensor Data Processing

The BNO08X analyzes the data from the 3-axis accelerometer, 3-axis gyroscope and 3-axis magnetometer. It manages the various sensors, reads data, and provides a number of outputs to the host. The BNO08X processes motion relative to a frame of reference. It has no knowledge of the orientation of sensors within the device and must be configured to conform to the desired frame of reference of the device. While the BNO08X is not necessarily used within Android systems, the frame of reference defined in the Android specification is used by the BNO08X software. In Android, the device frame of reference is represented as X axis horizontal, positive to the right, Y axis vertical, positive along the face of the device and Z axis positive towards the outside of the front face of the device. The frame of reference is shown in Figure 2-1.

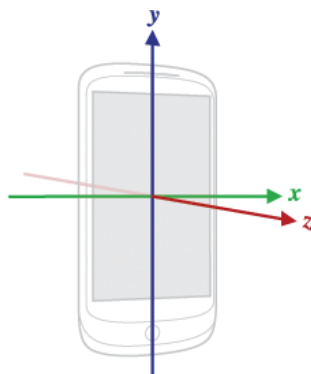

Figure 2-1: Android co-ordinate system

The BNO08X can be mounted within the device in any orientation that allows the PCB to be laid out efficiently. The BNO08X sensor orientation is provided in Figure 4-1.

The BNO08X needs to be configured to understand what the orientation is relative to the device frame of reference. This is achieved by modifying either the static calibration record if the device is passed through a calibration step or by modifying the sensor orientation records. Sensor orientation is discussed further in section 4.

2.1 Motion Outputs

Motion outputs allow applications to understand the motion being applied to the device as measured by BNO08X.

2.1.1 Acceleration Outputs

The 3-axis accelerometer measures the acceleration of the device (note that the accelerometer will measure gravity as acceleration). BNO08X calibrates the accelerometer output to improve the data reported. BNO08X will report this acceleration aligned to the coordinate frame of the device. BNO08X can (after fusing data with the gyroscope) separate gravity from this acceleration, thus providing the BNO08X with the following acceleration outputs:

- Calibrated Acceleration (m/s^2). Acceleration of the device including gravity
- Linear acceleration (m/s^2). Acceleration of the device with gravity removed
- Gravity (m/s^2)
- Raw uncalibrated accelerometer data (ADC units). Used for testing

Note that for raw data to be transmitted the accelerometer must be enabled by a separate set feature request, i.e. the raw sensor listens to an already configured sensor. The rate specified in the raw sensor set feature request cannot be higher than the underlying sensor configuration. The raw data will either be delivered at the same rate as the underlying sensor or at the rate requested (within the constraints of rate decimation).

2.1.2 Angular Velocity Outputs

The 3-axis gyroscope measures the angular velocity of the device. The angular velocity is reported as rotations around the X, Y, Z axes as depicted in Figure 2-1. A positive value is reported for counter-clockwise rotations. BNO08X calibrates this data to improve the measurement and provides the following outputs:

- Calibrated gyroscope (rad/s). The angular velocity of the device
- Uncalibrated gyroscope (rad/s). Angular velocity without bias compensation. This output is required for Android 4.4 compatibility. The bias is reported as a second parameter
- Raw uncalibrated gyroscope (ADC units). Data direct from the gyroscope, used for testing

Note that for raw data to be transmitted the gyroscope must be enabled by a separate set feature request, i.e. the raw sensor listens to an already configured sensor. The rate specified in the raw sensor set feature request cannot be higher than the underlying sensor configuration. The raw data will either be delivered at the same rate as the underlying sensor or at the rate requested (within the constraints of rate decimation).

2.1.3 Magnetometer Processing

While not actually a motion sensor, the magnetometer can be used to detect motion. The magnetometer measures the surrounding magnetic field and is used to determine absolute orientation as well as support other fusion operations. Absolute orientation can be thought of as determining which direction is magnetic north and evaluating the sensors orientation with respect to north.

The complication with measuring the magnetic field is that the field is distorted by the proximity of ferrous or magnetic material. The distortion caused by these materials is often referred to as the soft-iron and hard-iron effect. To remove this distortion the device must be moved sufficiently through all 3 axes (X, Y and Z) of 3-dimensional space. An indication of the degree of calibration is reported in the magnetometer reports accuracy field.

BNO08X provides the following magnetic field measurement outputs:

- Magnetic field calibrated (in μ Tesla). The fully calibrated magnetic field measurement.
- Magnetic field uncalibrated (in μ Tesla). The magnetic field measurement without hard-iron offset applied, the hard-iron estimate is provided as a separate parameter.
- Raw magnetic field measurement (in ADC units). Direct data from the magnetometer. Used for testing.

2.2 Orientation Outputs

One of the primary outputs of BNO08X is an estimation of the device orientation. Fusing data from accelerometers, gyroscopes and magnetometers has a rich history of usage for estimating orientation. BNO08X provides multiple estimates that have different tradeoffs as described below (note that the term rotation vector used below is derived from Google's definition in Android 4.4).

2.2.1 Geomagnetic Rotation Vector

The geomagnetic rotation vector is an orientation output that is expressed as a quaternion referenced to magnetic north and gravity. It is produced by fusing the outputs of the accelerometer and magnetometer. The gyroscope is specifically excluded in order to produce a rotation vector output using less power than is required to produce the rotation vector of section 2.2.4. The consequences of removing the gyroscope are:

- Less responsive output since the highly dynamic outputs of the gyroscope are not used
- More errors in the presence of varying magnetic fields

2.2.2 Game Rotation Vector

The game rotation vector is an orientation output that is expressed as a quaternion with no specific reference for heading, while roll and pitch are referenced against gravity. It is produced by fusing the outputs of the accelerometer and the gyroscope (i.e. no magnetometer). The game rotation vector does not use the magnetometer to correct the gyroscopes drift in yaw. This is a deliberate omission (as specified by Google) to allow gaming applications to use a smoother representation of the orientation without the jumps that an instantaneous correction provided by a magnetic field update could provide. Long term the output will likely drift in

yaw due to the characteristics of gyroscopes, but this is seen as preferable for this output versus a corrected output.

2.2.3 AR/VR Stabilized Game Rotation vector

While the magnetometer is removed from the calculation of the game rotation vector, the accelerometer itself can create a potential correction in the rotation vector produced (i.e. the estimate of gravity changes). For applications (typically augmented or virtual reality applications) where a sudden jump can be disturbing, the output is adjusted to prevent these jumps in a manner that takes account of the velocity of the sensor system. This process is called AR/VR stabilization. An FRS (Flash Record System – see Figure 1-31) record is provided to allow configuration of this feature.

2.2.4 Rotation Vector

The rotation vector provides an orientation output that is expressed as a quaternion referenced to magnetic north and gravity. It is produced by fusing the outputs of the accelerometer, gyroscope and magnetometer. The rotation vector is the most accurate orientation estimate available. The magnetometer provides correction in yaw to reduce drift and the gyroscope enables the most responsive performance.

2.2.5 AR/VR Stabilized Rotation Vector

Estimates of the magnetic field and the roll/pitch of the device can create a potential correction in the rotation vector produced. For applications (typically augmented or virtual reality applications) where a sudden jump can be disturbing, the output is adjusted to prevent these jumps in a manner that takes account of the velocity of the sensor system. This process is called AR/VR stabilization. An FRS (Flash Record System – see Figure 1-31) record is provided to allow configuration of this feature.

2.2.6 Gyro rotation Vector

Head tracking systems within a virtual reality headset require low latency processing of motion. To facilitate this, the BNO08X can provide a rotation vector at rates up to 1kHz. The gyro rotation Vector provides an alternate orientation to the standard rotation vector. Compared to the standard rotation vector the gyro rotation vector has an optimized processing path and correction style (correction is the adjustments made to the output based on more accurate estimates of gravity, mag field, angular velocity) that is suitable for head tracking applications.

By default the Gyro rotation vector provides an orientation output that is expressed as a quaternion. It can be configured via FRS record to be based on either the rotation vector (using the magnetometer) or the game rotation vector (ignoring the magnetometer).

2.2.7 Gyro rotation Vector Prediction

In virtual reality systems reducing latency is a vital requirement to providing an immersive experience. The gyro rotation vector provides a low latency output. However in a system there are many factors that can add to the latency budget:

- IMU processing
- Data path between IMU and video rendering
- Video rendering
- Video buffer/display write

To aid in the reduction of the overall system latency the BNO08X can derive an expected orientation for some time in the future. Predicting 20-30 ms into the future can significantly improve the perception of reality within the virtual reality world. The predictor accepts the gyro rotation vector as input and produces a second rotation vector for some time in the future. An FRS record is used to tune the predictor for the type of motion. The predictor accepts three constants (alpha, beta, gamma) for the tuning.

The default prediction time is 28ms and is determined for motion typical of a head tracker. Some typical parameters that can be used are captured in Figure 2-2. These values are all for motion typical of a head tracker.

Prediction Time (s)	Alpha	Beta	Gamma	Max error (deg)	rms error (deg)	Noise StdDev (deg)
0.028	0.3030725439091	0.1132958963849	0.0027762197131	1.96°	0.19°	0.019°
0.005	0.3643672983581	0.0931655637068	0.0025557744608	0.25°	0.01°	0.003°
0.01	0.3222569517214	0.0945467654507	0.0022830845312	0.54°	0.03°	0.005°
0.02	0.2905555274225	0.1018361851286	0.0023953721024	1.26°	0.1°	0.011°
0.03	0.3084584610521	0.1160861868509	0.0028497585549	2.14°	0.22°	0.021°
0.04	0.3396316005051	0.1237361273333	0.0030844488660	3.23°	0.4°	0.034°
0.05	0.3548447957314	0.1224432975403	0.0032236047505	4.8°	0.64°	0.051°
0.06	0.4091677424529	0.1250943899234	0.0035648974825	7.03°	0.93°	0.072°

Figure 2-2: HMD mounted head motion prediction

For other applications contact CEVA.

2.3 Environmental Sensors

The BNO08X provides support for environmental sensors connected over an I²C interface (separate to the host interface). Currently the BNO08X supports:

- Bosch Sensortec BME280 pressure/humidity/temperature sensor
- Bosch Sensortec BMP280 pressure/temperature sensor (only BMP280 or BME280 should be populated)
- Capella Microsystems CM36686 proximity and ambient light sensor

If the sensors are not required for a particular application the I2C bus should be correctly terminated with pullup resistors as the BNO08X attempts to discover the sensors at reset. Proper termination will ensure correct behavior of the BNO08X.

The ALS and proximity sensors typically require calibration as these sensors are typically placed behind glass or plastic. Contact CEVA for details.

2.4 Classification System

With the proliferation of sensors available within mobile devices, there is an increasing interest in providing value by understanding the context of the device or device holder. Classifying the context based on the sensors available is an active area of research with an emphasis of the classifiers being 'always on', so low power is an inherent requirement. BNO08X supports a number of classifiers that generate events upon detection of a particular context or motion.

2.4.1 Stability Detection and Classification

Analysis of the motion sensors allows BNO08X to classify stability. BNO08X provides two virtual sensors to quantify stability: a stability detector and a stability classifier.

The stability classifier uses both the accelerometer and gyroscope to distinguish between three levels of stability:

- On table: the device is likely on a table or other stable surface
- Stable: the device is likely being held, but held in a stationary manner
- Motion: the device or device holder is in motion

The stability detector uses the accelerometer to distinguish between stability and motion.

Both the classifier and detector have configurable thresholds for the levels of stability. These thresholds are stored as FRS records as described in the SH-2 Reference Manual [1].

The stability detector has an acceleration threshold which is the aggregate acceleration of the device. The default value is 0.784m/s². The stability detector also includes a time threshold. The acceleration of the device must stay below the threshold set for the duration of the time record to register as stable. The default value is 500ms.

The FRS record that configures the stability classifier is encoded in the MotionEngine power management and stability classifier FRS record. The FRS record provides a stable threshold and a duration threshold. The data from the gyroscope must be below the stable threshold for the duration threshold period for Stable to be declared. The default values are 1 rad/s and 3s respectively. The static calibration record for the device contains parameters that describe the noise floor of the gyroscope. Comparison of the gyroscope's output to the expected noise of the system allows for a very reliable measure of high stability, such as one might see when the device is on a table.

Note that the stability detector is lower power than the stability classifier due to the sensors used (accelerometers currently consume less power than gyroscopes).

2.4.2 Tap Detector

The tap detector evaluates data from the accelerometer and generates an event when either a single or double tap is detected. The output of the tap detector indicates the axis along which the tap was detected and whether the tap was a single or a double tap. The axes are aligned to the Android frame of reference (Figure 2-1).



Figure 2-3: Tap detector

2.4.3 Step Detector

The step detector uses data from the accelerometer to detect steps. It will output a value of 1.0 whenever a step is detected. The step detector has two optimizations, one for wrist worn devices and the second for all other use cases.

The step detector has built in defaults (listed below). Modification of these values, while not recommended, is possible. Consultation with CEVA is advised.

Configurable options:

- watchSelector: 1 for wrist worn devices, 0 otherwise
- allowTime: max variation of step period. Default value 250ms
- stepMinTime: minimum step period. Default value 300ms
- groupDelay: group delay of the filter. Filtering of accelerometer data is required to ensure accurate detection of steps, particularly if the accelerometer is rotating with respect to gravity. The group delay of the filter is a compromise between responsiveness and error accumulation. A value of 90ms is used and the user is discouraged from modifying this value without consultation with CEVA.
- threshold: vertical motion threshold. The threshold in meters below which a step would not be recognized. Default is 3.1mm
- thresholdWatch: A second threshold used for wrist worn devices. The default value is 0.01
- thresholdNonWatch: A second threshold for devices other than wrist worn. The default value is 1.2×10^{-4}

2.4.4 Step Counter

The step counter uses the step detector to detect and count steps. It provides a more accurate indication of steps taken than the step detector. It provides increased accuracy by evaluating the data around each step event, possibly reclassifying previous samples as either steps or non-steps, depending upon the patterns perceived. It outputs a 16-bit step count. The application processor maintains a 64-bit count of the total number of steps taken and must therefore manage any roll-overs in the step counter output. The step counter will assert the host interrupt while the host processor is asleep if the 16-bit step counter is close to overflow to ensure steps are not lost.

The step counter has two optimizations, one for wrist worn devices and the second for all other use cases.

2.4.5 Activity Classification

The activity classifier uses the accelerometer to determine if the user is walking, running or climbing stairs. The climbing stairs feature requires the use of an external pressure sensor. The sensor is configurable to allow customization for a particular device and/or a particular individual. The configurable options relate to the step rate for running versus walking and to the variation of the signal strength of the accelerometer.

The configurable options are:

Thresholds related to Step Rates

- `runLowerThldStep`: The lowest step rate for running. The default is 1.25 steps/s
- `walkUpperThldStep`: The highest step rate for walking. The default is 2.25 steps/s
- `walkLowerThldStep`: The lowest step rate for walking. The default is 0.75 step/s

Thresholds related to Step Signal Variation Strength:

- `runUpperThldStd`: The highest signal variation strength for running. The default is 23.50m/s²
- `runLowerThldStd`: The lowest signal variation strength for running. The default is 3.20m/s²
- `walkUpperThldStd`: The highest signal variation strength for walking. The default is 4.50m/s²
- `walkLowerThldStd`: The lowest signal variation strength for running. The default is 0.75m/s²

The classification considers steps within a 4s window and the variation in signal strength is determined by taking the standard deviation of the accelerometer normal over the 4s window.

With the default settings a classification matrix as depicted in Figure 2-4 can be created.

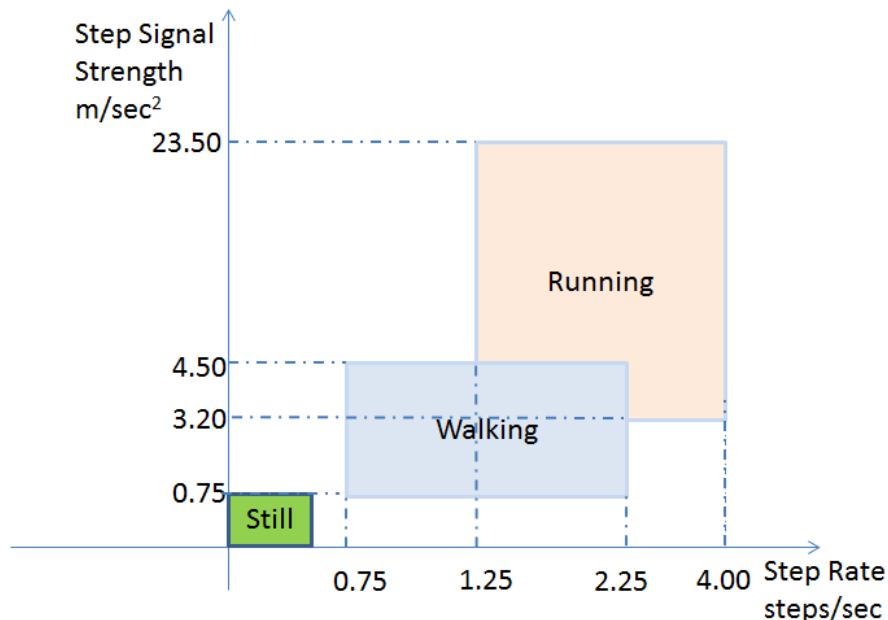

Figure 2-4: Activity classification matrix

2.4.6 Significant Motion Detector

The significant motion detector was introduced by Google in Android 4.3 (API level 18). The definition is that an event should be raised when a user has created motion that implies they have changed location. The typical use-case is that the sensor be low power (as it can run while the phone is asleep) and that it alerts the main processing element of the device when a change in location is likely. BNO08X uses the step detector and processing based on the accelerometer to determine if the user has created significant motion. The detector outputs a value of 1.0 when an event occurs. Per the Android specification this detector will disable itself immediately after the event is output.

Configuration of the significant motion detector requires configuration of the following two parameters:

- Significant motion step threshold. The number of steps required to trigger the event. The default value is 5 steps.
- Acceleration threshold. A threshold loosely based on the device's acceleration to trigger significant motion processing. Default value is 10m/s^2

2.4.7 Shake Detector

The shake detector determines if the device has been shaken. It can be used as a wake-up sensor or for UI interaction. It has a number of configurable options:

- Magnitude of acceleration that must be exceeded. Default 8m/s^2
- Number of direction changes to qualify as a shake and the axis of interest. Default of 3
- Minimum and maximum time between direction changes. Default: $50\text{ms} < \text{time} < 400\text{ms}$
- Which device axis to detect shake along (X, Y or Z). Default: all axes.

The configuration parameters are stored in the shake detector configuration FRS record.



Figure 2-5: Shake gesture

3 Calibration and Interpretation

The BNO08X interprets the data from its sensors to model the device's motion and ultimately determine the device's orientation and classify the motion of the device. The accuracy of this model is dependent on the quality of the data provided by the sensors.

All sensors exhibit slight imperfections. These imperfections generally appear as errors in offset and scale. Sensor systems that contain three axes have an additional variant of offset that includes skew and rotation (skew is the non-orthogonality of the three axes and rotation is the angular difference of the coordinate frame of the sensor to the coordinate frame of the device). Calibration of the sensor data falls into two categories:

- Static calibration
- Dynamic calibration

Static calibration is the correction of non-varying parameters to the data returned from the sensors. These static adjustments to the data typically compensate for offsets and scaling errors that do not vary over time or with temperature. Examples (this list is not exhaustive) of non-varying errors (or errors that are not compensated for dynamically) are:

- Accelerometer (or gyroscope or magnetometer) skew (also called cross-axis sensitivity)
- Accelerometer (or gyroscope or magnetometer) gain or sensitivity
- Sensor orientation with respect to device frame of reference

A static calibration data record (SCD) is essentially a description of the sensor system used on the device and from that record the BNO08X calibrates and interprets the data from the sensors producing data in the appropriate SI units for use by applications. The SCD record can be generic and essentially describe the sensors as per the datasheet, or the record can be specific to the actual sensors in the package.

Dynamic calibration is the correction to the data returned from the sensors that varies with either time or temperature. The BNO08X calculates what the adjustment should be during use of the sensor and applies correction factors as necessary in real time. Examples of dynamic calibration parameters are:

- Gyroscope zero-rate offset
- Accelerometer zero-g offset

In addition, as the BNO08X has applications in devices such as Robot Vacuum Cleaners it is necessary to calibrate the accelerometer in a planar fashion (i.e. around the axis that the vacuum cleaner revolves). Selection of 3D or planar accelerometer calibration is via command.

Magnetic field calibration is an additional capability of the BNO08X. The primary goal of using the magnetometer is to measure the Earth's magnetic field. The magnetic field measured by a magnetometer is distorted by the presence of ferrous and magnetic material in the near vicinity. These distortions are referred to as soft and hard iron effects respectively. The offset and distortion to the measured magnetic field is estimated and compensated for continuously while the device is in motion. Removal of the distortions allows for an improved estimate of the Earth's magnetic field.

3.1 Calibration Effects

This section provides a brief overview of the benefits of dynamic calibration and the recommended settings for various applications.

3.1.1 Calibration Command

The SH-2 firmware in the BNO08X allows a host microcontroller to enable or disable the dynamic calibration of the accelerometer, gyroscope and magnetometer. Refer to the SH-2 Reference Manual [1] for the command used to control calibration of each sensor. The command allows the host to control when calibration is performed. Note that the calibration settings do not persist across resets of the BNO08X.

3.1.2 Accelerometer

Dynamic calibration for an accelerometer is the removal of zero-g offset (ZGO). An accelerometer at rest should only report gravity, any deviation is the zero-g offset. This is most easily seen when the accelerometer is placed with one axis perpendicular to the Earth, the other two axes should report zero. ZGO errors can manifest as tilts or tilt corrections (e.g. the screen on a head mounted display may be tilted with respect to the expected horizon) and this usually indicates that the accelerometer needs to be calibrated. The BNO08X provides two methods of calibrating the accelerometer ZGO; a full 3-dimensional approach for devices that can move in freely in space and a planar calibration for devices that are constrained to move in a plane (such as a robot vacuum cleaner). For more information on calibrating the accelerometer, see section 3.2.

3.1.3 Gyroscope

Dynamic calibration for a gyroscope is the removal of zero rate offset (ZRO). A gyroscope at rest should report zero rad/s on all axes. Any deviation from zero is the zero rate offset (ZRO). ZRO errors can manifest as drifts (e.g. the screen on a head mounted display can continue moving even when the device is stationary). Note that though the BNO08X can continuously attempt to calibrate the gyroscope for ZRO, it is possible to fool the calibration algorithms through slow horizontal rotations (around the gravity vector). Placing the device on a stable surface will force the ZRO calibration to converge rapidly. The gyroscope calibration algorithm attempts to remove ZRO while the device is not on a very stable surface. For this to be successful the device to which the BNO08X is mounted must have sufficient tremor such as the human hand. If there is insufficient tremor it is advisable to disable the gyroscope calibration to prevent drift (i.e. by mis-calibrating ZRO). ZRO will always be corrected when the device becomes very stable (such as when laid on a table).

3.1.4 Magnetometer

Magnetometers measure the magnetic field around them and the typical use case is to determine the position of the Earth's magnetic North pole. The magnetic field can be distorted by the presence of magnetic fields caused by speakers, magnets etc. (hard-iron effects) or other ferrous materials (soft-iron effects). BNO08X can dynamically calibrate the readings from the magnetometer to compensate for these distortions. Without calibration the heading reported by BNO08X will be highly suspect so it is highly recommended to calibrate the magnetometer. For more information on calibrating the magnetometer, see section 3.2.

3.1.5 Calibration Accuracy

The BNO08X provides input reports (see section 1.3.5) to send sensor data to the host microcontroller. The input reports include a "Status" field that indicates the accuracy status of the sensor. This is especially useful when the application needs to know the calibration status of the BNO08X outputs. Bits 1:0 of the Status field indicate the accuracy as shown in Figure 3-1. Refer to the SH-2 Reference Manual [1] for more information.

Status Bits (1:0)	Description
0	Unreliable
1	Accuracy Low
2	Accuracy Medium
3	Accuracy High

Figure 3-1: Accuracy status of sensors

3.1.6 Recommended Settings

Note that by default the accelerometer and magnetometer calibration are enabled for all interface modes except UART-RVC. In UART-RVC mode planar-ZGO calibration is enabled.

For general applications that require motion tracking in a relatively stable magnetic field it is recommended to use 9-axis sensor fusion outputs (Rotation Vector – see section 2.2.4) from the BNO08X. If the device to which the BNO08X is attached provides sufficient tremor then the gyroscope calibration can be enabled. However the user should verify performance with their specific motion profile.

If the application requires an orientation estimate in an unstable magnetic field, the Game Rotation Vector may be more useful.

For virtual reality applications, stability and smoothness of head tracking is important. During application use dynamic calibration of the magnetometer can result in undesirable motion artifacts such as jumps as the BNO08X attempts to compensate for magnetic field distortions. It is therefore recommended to use the Game Rotation Vector (see section 2.2.2) or gyro rotation Vector (see section 2.2.6 and 2.2.7) and only enable the calibration of the accelerometer.

For RVC applications it is generally expected that the UART-RVC mode be used and in this case planar ZGO will be enabled by default. If the user has a similar application but requires higher rate outputs then alternate interfaces can be used. The planar accelerometer calibration can be enabled by the user.

3.2 Calibration Steps

For best motion tracking performance, it is recommended to calibrate the BNO08X. Since each MEMS sensor part has different individual characteristics, each device using the BNO08X must be calibrated individually.

Figure 3-2 summarizes the steps required to calibrate the accelerometer, gyroscope and magnetometer. For more details on the procedure to calibrate the BNO08X, refer to the BNO08X Sensor Calibration Procedure application note [7]. Note that in normal use the device will be exposed to conditions that will allow calibration to occur with no explicit user input. The steps are provided below if a user wants to force a calibration.

Sensor	Calibration Procedure
Accelerometer	<ul style="list-style-type: none"> For 3D calibration the device should be moved into 4-6 unique orientation and held in each orientation for about 1 second to calibrate the accelerometer For planar calibration the device should be rotated around it Z-axis by at least 180 degrees
Gyroscope	Device should be set down on a stationary surface for approximately 2-3 seconds to calibrate the gyroscope
Magnetometer	Device should be rotated about 180° and back to the beginning position in each axis (roll, pitch and yaw). Device should be rotated about 2 seconds on each axis.

Figure 3-2: Calibration procedure for sensors

3.3 Interactive Calibration (BNO086 only)

As discussed in section 3.1.3, removal of gyroscope ZRO is critical to reduce heading drift. For applications in which low heading drift is vital, the BNO086 offers a means of calculating and removing the ZRO more frequently and more accurately than the normal opportunistic dynamic calibration. This method is called Interactive Calibration and involves cooperation between the host application and the BNO086 to identify emerging needs to update calibration and provide specific opportunities to update the calibration. See reference 0 for more details.

3.4 Persist Dynamic Calibration Data

The BNO08X stores updated Dynamic Calibration Data (DCD) to RAM frequently (every 5 seconds). At non-power-up reset, the hub will persist the last-stored DCD from RAM to FRS. To clear the DCD from RAM before system reset, use the Clear-DCD and Reset command [1].

For SHTP applications, the last stored DCD can be saved to FRS during operation through specific commands; the Save DCD request and the Configure Periodic DCD Save command. More details are available in [1].

4 BNO08X Orientation

The BNO08X can be mounted in an arbitrary manner that facilitates the manufacture of the device it is included within. The outputs of the BNO08X must however be aligned to a frame of reference that is practical to the user. This essentially requires mapping the orientation of the BNO08X to the orientation of the device within which it is housed. Re-mapping of the BNO08X's sensor outputs to the supporting device's frame of reference is achieved by programming an FRS record. The system orientation FRS record (0x2D3E) applies a rotation to the sensor outputs and all the derived outputs (e.g. rotation vectors). The system orientation record is a unit quaternion, with each coordinate represented as a 32-bit fixed point number with a Q-point of 30 to represent a fractional number.

The default BNO08X axis orientation is shown in Figure 4-1. A positive value is reported for counter-clockwise rotations.

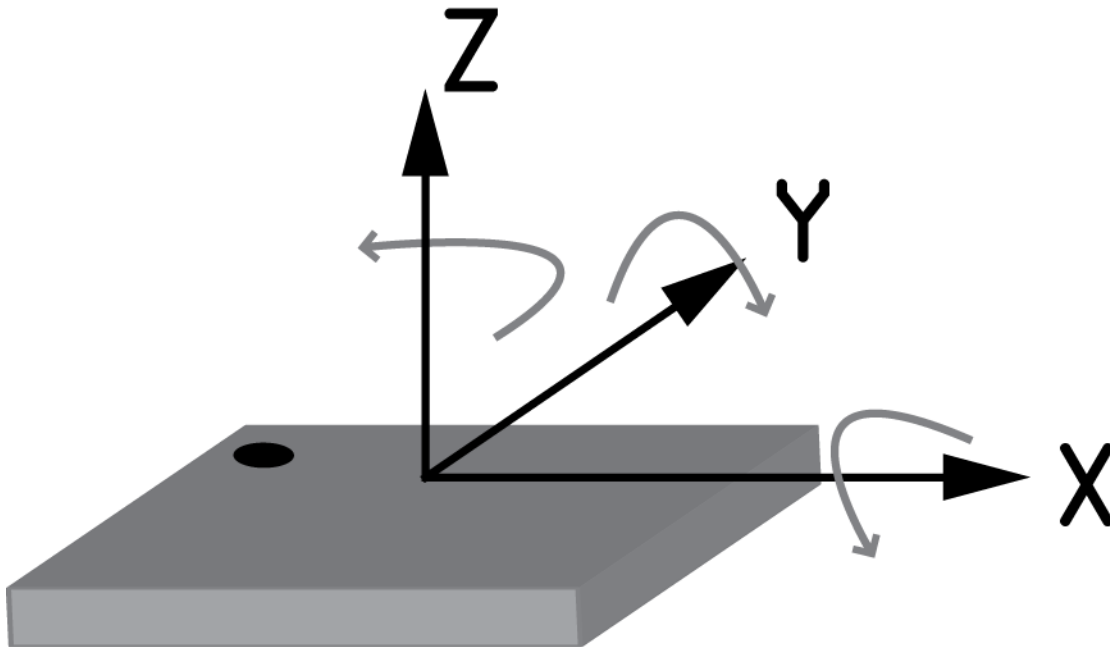

Figure 4-1: BNO08X axis orientation

If the BNO08X was mounted such that its positive Y-axis was aligned opposite to the X-axis of the device it was mounted in, but with its Z-axis aligned correctly, a clockwise rotation of 90° around the Z-axis would be required (see Figure 4-2).

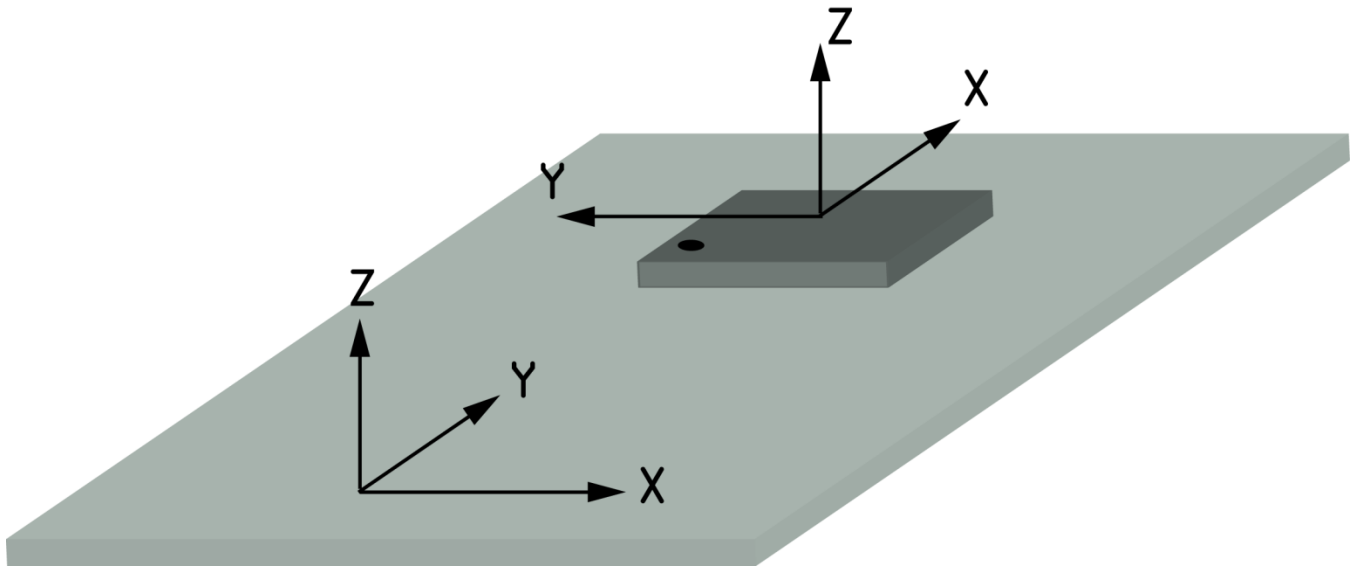

Figure 4-2: BNO08X mounted in a device

This rotation would be represented by a quaternion of $(\frac{\sqrt{2}}{2}, 0, 0, \frac{\sqrt{2}}{2})$.

Assume that for the device the BNO08X is mounted in, the Z-axis is Up, the X-axis is East and the Y-axis is North. Examples of mappings for BNO08X mounting are provided below to clarify the use of the FRS record:

BNO08X physical axis aligned			Mapping quaternion			
X	Y	Z	Qw	Qx	Qy	Qz
East	North	Up	1	0	0	0
North	West	Up	$(\sqrt{2})/2$	0	0	$(\sqrt{2})/2$
West	South	Up	0	0	0	1
South	East	Up	$(\sqrt{2})/2$	0	0	$-(\sqrt{2})/2$
East	South	Down	0	0	-1	0
North	East	Down	0	$-(\sqrt{2})/2$	$-(\sqrt{2})/2$	0
West	North	Down	0	-1	0	0
South	West	Down	0	$-(\sqrt{2})/2$	$(\sqrt{2})/2$	0
Up	South	East	0	0	$-(\sqrt{2})/2$	$(\sqrt{2})/2$
North	Up	East	1/2	-1/2	-1/2	1/2
Down	North	East	$(\sqrt{2})/2$	$-(\sqrt{2})/2$	0	0
South	Down	East	1/2	-1/2	1/2	-1/2
Up	North	West	$-(\sqrt{2})/2$	$-(\sqrt{2})/2$	0	0
North	Down	West	-1/2	-1/2	-1/2	-1/2
Down	South	West	0	0	$-(\sqrt{2})/2$	$-(\sqrt{2})/2$
South	Up	West	1/2	1/2	-1/2	-1/2
Up	East	North	-1/2	-1/2	-1/2	1/2
West	Up	North	0	$-(\sqrt{2})/2$	0	$(\sqrt{2})/2$
Down	West	North	1/2	-1/2	1/2	1/2
East	Down	North	$-(\sqrt{2})/2$	0	$-(\sqrt{2})/2$	0
Up	West	South	1/2	1/2	-1/2	1/2
West	Down	South	0	$-(\sqrt{2})/2$	0	$-(\sqrt{2})/2$
Down	East	South	1/2	-1/2	-1/2	-1/2
East	Up	South	$(\sqrt{2})/2$	0	$-(\sqrt{2})/2$	0

Figure 4-3: Multiple 90 degree rotations

The highlighted row is also shown pictorially in Figure 4-2. For rotations that are not a multiple of 90 degree rotations the appropriate angular rotations should be applied.

4.1.1 Tare

The outputs generated by BNO08X can also be oriented under user control by a tare function. Taring allows a user to mount the BNO08X in an arbitrary manner and by invoking the tare command the SH-2 software will determine the orientation that needs to be applied to the outputs to align with an East, North, Up frame of reference. This orientation will then be applied to all motion outputs.

If the Rotation Vector or Geomagnetic Rotation Vector is necessary for the application, the BNO08X must have resolved magnetic North before applying the tare function. Otherwise when the magnetometer calibrates the heading will change.

4.1.1.1 Types of Tare

There are two types of tare defined, tare around all axes and tare around the Z-axis. A tare around all axes solves for tilt and heading. A tare around the Z-axis only solves for the heading. In an HMD application, the all-axis tare is useful for initial adjustment, further adjustments are likely for heading reasons and then the tare-Z may be more applicable.

The result of a tare function is applied wherever power is applied to the device. To ensure the reorientation is permanent there is a Persist Tare function to allow storage of the orientation configuration. Note that if tare-Z is used for the Game Rotation Vector, then the BNO08X must be reset. At startup, the BNO08X will apply the new orientation to the Game Rotation Vector. Persist tare does not apply to the Game Rotation Vector.

Refer to the BNO08X Tare Function Usage Guide application note [8] for more information on how to use tare.

5 Getting Started with BNO08X

5.1 BNO08X in UART-RVC mode

When the BNO08X is configured for UART-RVC mode it starts up and sends a string containing the following information:

```
%Hillcrest Labs 10003608
%SW Ver 3.2.x
%(c) 2017 Hillcrest Laboratories, Inc.
```

This message informs the user that the BNO08X has exited reset and provides version information.

Following this message the BNO08X will issue packets according to 1.2.5.2

5.2 BNO08X in non UART-RVC configurations

The BNO08X starts up with all sensors disabled, waiting for the application processor (AP) to configure it. The following sections provide details of typical sequences to enable features on the BNO08X.

5.2.1 Establishing Contact

After power up or reset the BNO08X will assert the interrupt (HOST_INTN) indicating that the reset routine has completed and that the BNO08X is ready for communication. A read from the BNO08X will return the initial SHTP advertisement packet. This packet details the SHTP channel assignments and packet length parameters (see [1] and [2]). Following the SHTP advertisement packet, the individual applications built in to the BNO08X will send a packet indicating they have left the reset state:

- The executable will issue a reset message on SHTP channel 1
- SH-2 will issue an unsolicited initialization message on SHTP channel 2

Beyond these initial messages the BNO08X will wait for configuration by the host.

5.2.2 Reading/Writing the BNO08X

After reset the sensor hub resides in a sleep state waiting for functionality to be enabled. The sensors or functions (detailed in section 2) to enable are application dependent. For example setting the accelerometer report for a period of 60ms (useful for screen rotation analysis in mobile phones) would be achieved by a Set Feature report as shown in Figure 5-1. The report ID for the accelerometer is 0x1 and a period of 60ms (or 60,000 μ s) equates to a report interval of 0x0000EA60.

Byte	Description
0	SHTP LSB = 0x15
1	SHTP MSB = 0x00
2	SHTP channel = 0x02
3	SHTP sequence number
4	Report ID = 0xFD
5	0x1
6	0
7	0
8	0
9	0x60
10	0xEA
11	0
12	0

Byte	Description
13	0
14	0
15	0
16	0
17	0
18	0
19	0
20	0

Figure 5-1: BNO08X set feature report (accelerometer) including SHTP header

Once set the BNO08X will issue a get feature response report and then provide input reports at the period set in the get feature response report. Note that the get feature response may provide a different period than was requested due to the supported rates in the underlying physical sensor. The BNO08X will also respond with a Get Feature Response if the sensor's reporting period is changed. The reporting period can change if a sensor is turned on/off or if as a result of another sensor being enabled or disabled the sensor's rate must be modified. The sensor input report will be preceded by a timebase reference packet. A report including SHTP header will have the format as seen in

Byte	Description	Packet type
0	Length LSB = 19	SHTP header
1	Length MSB = 0	
2	Channel = 3	
3	Sequence Number	
4	Report ID = 0xFB (Timebase Reference)	Timebase reference
5	Base Delta LSB	
6	Base Delta	
7	Base Delta	
8	Base Delta MSB	Accelerometer input report
9	Report ID = 0x01 (accelerometer)	
10	Sequence number	
11	Status	
12	Delay	
13	Accelerometer Axis X LSB	
14	Accelerometer Axis X MSB	
15	Accelerometer Axis Y LSB	
16	Accelerometer Axis Y MSB	
17	Accelerometer Axis Z LSB	
18	Accelerometer Axis Z MSB	

Figure 5-2: Accelerometer & timebase input report including SHTP header

6 BNO08X Characteristics

This section describes the electrical and performance characteristics of the BNO08X. The BNO08X is a custom part that CEVA provides based upon the Bosch Sensortec BMF055. All of the BNO08X I/O pins meet CMOS and TTL requirements.

Note that the electrical and mechanical sections of the specification reported here are reproduced from the Bosch Sensortec BMF055 datasheet. The data in this section is reported for convenience, the reader is encouraged to consult the BMF055 datasheet [5] to verify all parameters.

6.1 Absolute Maximum Electrical Ratings

Exposure to maximum rating conditions for extended periods may affect device reliability.

Parameter	Symbol	Conditions	Rating	Unit
Voltage at supply pin	V_{DDIO}		-0.3 to 3.63	V
	V_{DD}		-0.3 to 4.25	V
Voltage at any logic pin	$V_{non-supply}$		$V_{DDIO}+0.3$	V
Storage temperature	T_{rps}	$\leq 65\%$ rel. H	-50 to +150	$^{\circ}\text{C}$
Mechanical shock	$\text{MechShock}_{200\mu\text{s}}$	Duration $\leq 200\mu\text{s}$	10,000	g
	$\text{MechShock}_{1\text{ms}}$	Duration $\leq 1.0\text{ms}$	2,000	g
	$\text{MechShock}_{\text{freefall}}$	Free fall onto hard surfaces	1.8	m
ESD	ESD_{HBM}	HBM at any pin	2	kV
	ESD_{CDM}	CDM	500	V
	ESD_{MM}	MM	200	V

Figure 6-1: BNO08X maximum ratings

6.2 Recommended Operating Conditions

Parameter	Symbol	Conditions	Min	Typ	Max	Unit
Supply voltage (μC and I/O Domain)	V_{DDIO}		1.7		3.6	V
Supply voltage (only sensors)	V_{DD}		2.4		3.6	V
Operating temperature			-40		85	$^{\circ}\text{C}$

Figure 6-2: BNO08X operating conditions

6.3 Power Management

The BNO08X has two distinct power supply pins:

- V_{DD} is the main power supply for the internal sensors
- V_{DDIO} is the power supply pin used for the supply of the internal microcontroller and the digital interfaces.

For the switching sequence of power supply V_{DD} and V_{DDIO} , it is mandatory that V_{DD} is powered on and driven to the specified level before or at the same time as V_{DDIO} is powered ON. Otherwise there are no limitations on the voltage levels of both pins relative to each other, as long as they are used within the specified operating range.

The reader is encouraged to read sections 1 and 3.2 of the BMF055 [5] datasheet for more information.

6.4 Electrical Characteristics

Parameter	Symbol	Conditions	Min	Typ	Max	Unit
Input high voltage	V_{IH}	$V_{DDIO}=1.7-2.7V$	$0.7*V_{DDIO}$			V_{DDIO}
		$V_{DDIO}=2.7-3.6V$	$0.55*V_{DDIO}$			V_{DDIO}
Input low voltage	V_{IL}	$V_{DDIO}=1.7-2.7V$			$0.25*V_{DDIO}$	V_{DDIO}
		$V_{DDIO}=2.7-3.6V$			$0.3*V_{DDIO}$	V_{DDIO}
Output high voltage	V_{OH}	$V_{DDIO} > 1.7V, I_{OH}=10mA$	$0.8*V_{DDIO}$	$0.9*V_{DDIO}$		V_{DDIO}
Output low voltage	V_{OL}	$V_{DDIO} > 3V, I_{OL}=20mA$		$0.1*V_{DDIO}$	$0.2*V_{DDIO}$	V_{DDIO}
POR Voltage threshold on VDDIO-IN rising	V_{DDIO_POT+}	V_{DDIO} falls at 1V/ms or slower		1.45		V
POR Voltage threshold on VDDIO-IN falling	V_{DDIO_POT-}			0.99		V

Figure 6-3: BNO08X electrical characteristics

6.5 AC Characteristics

6.5.1 I²C Timing

The I²C interfaces of the BNO08X are compliant with the I²C specification [4]. The BNO08X provides master functionality to the environmental sensors and slave functionality to the application processor

Parameter	Symbol	Conditions	Min	Max	Unit
SCL clock frequency				400	kHz
SCL high period	t_{high}		0.6		μs
SCL low period	t_{low}		1.3		μs
Rise time for SCL and SDA		$10pF < C_b < 400pF$	$20+0.1C_b$		ns
Fall time for SCL and SDA		$10pF < C_b < 400pF$	$20 + 0.1C_b$		ns
SDA setup time	t_{su}		0.1		μs
SDA hold time	t_h		0		μs
Hold time for start condition	t_{hst}		0.6		μs
Setup time for a stop condition	t_{susp}		0.6		μs
Idle time between accesses	t_{bf}		1.3		μs

Figure 6-4: I²C timing parameters

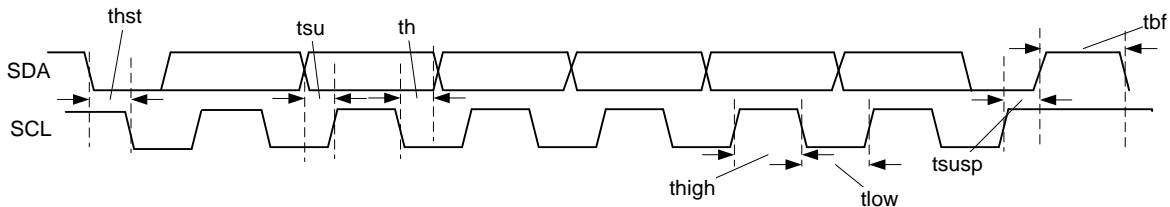

Figure 6-5: I²C timing

6.5.2 SPI timing

The Serial Peripheral Interface (SPI) is a synchronous serial interface. The BNO08X implements the slave side of the interface for host communications. The BNO08X supports 4 wire mode and implements SPI mode 3: CPOL = 1 and CPHA = 1. SPI mode 3 implies that the clock idles at '1' and that data is clocked in on the positive edge.

Parameter	Symbol	Min	Typ	Max	Unit
SPI (CLK) clock frequency				3	MHz
SPI clock period	tck	0.33			μs
SCL high period	tckh		0.5*tck		
SCL low period	tckl		0.5*tck		
CS setup to CLK	tcssu	0.1			μs
CS hold	tcssh	16.83			Ns
CS to MISO out	tcsso			31	ns
CLK to MISO out valid	tsov			35	ns
MISO hold	tsoh	13.7			ns
MISO hold after CS	tcssoh	7.4			ns
MOSI setup time	tsisu	25			ns
MOSI hold time	tsih	5.4			ns

Figure 6-6: SPI timing parameters

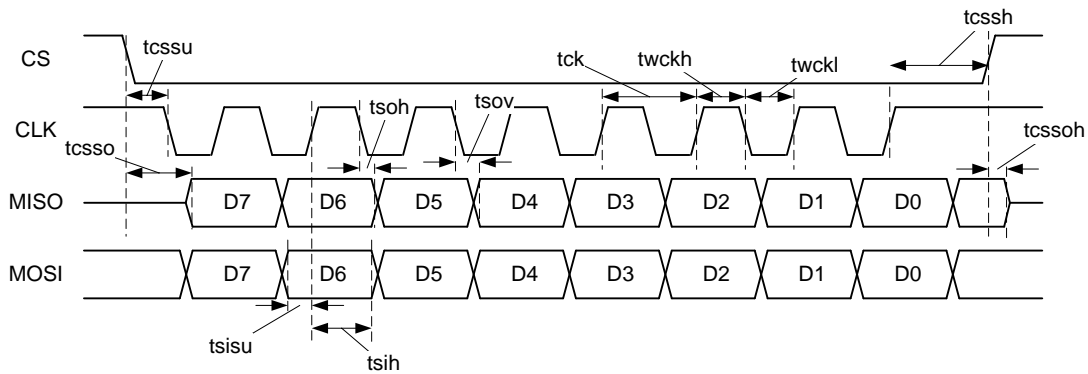

Figure 6-7: SPI timing

6.5.3 Startup timing

The timing for BNO08X startup for I2C and SPI modes is show below. The host may begin communicating with the BNO08X after it has asserted H_INTN. In UART mode, the BNO08X sends an advertisement message when it is ready to communicate.

Parameter	Symbol	Min	Typ	Max	Unit
Reset signal	t _{nrst}	10			ns
Internal Initialization	t ₁	90			ms
Internal configuration	t ₂		4		ms

Figure 6-8: SPI timing parameters

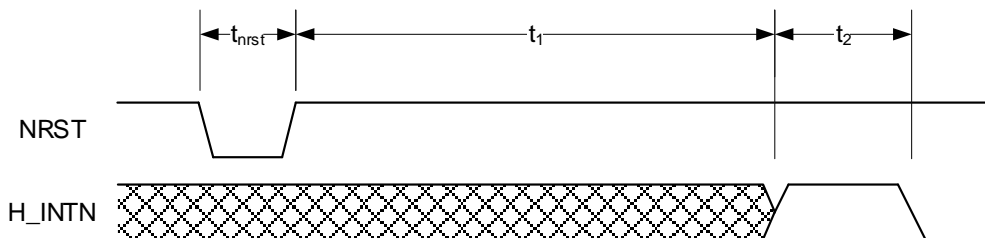

Figure 6-9: Startup timing

6.5.4 Interrupt timing

In SPI and I²C mode the HOST_INTN signal is used by the BNO08X to indicate to the application processor that the BNO08X needs attention. The signal is active low and is asserted until either the end of the I²C device address is registered or the SPI chip select is observed.

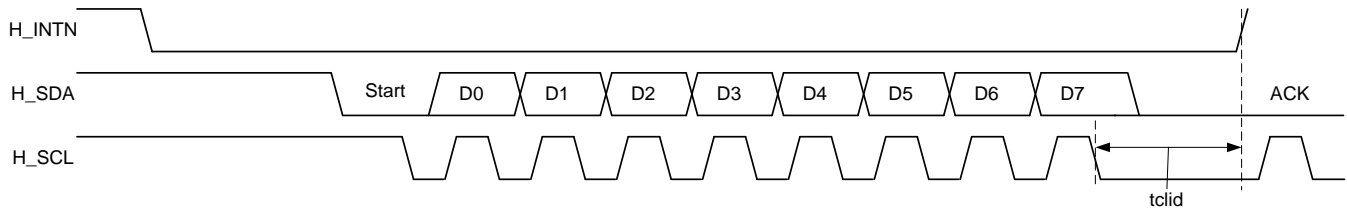

Figure 6-10: Host interrupt timing – I²C mode

If the BNO08X is asleep the host can wake it by assertion of the wake signal. The BNO08X will assert the interrupt line to indicate it is awake. If the BNO08X interrupted the host then it is already awake.

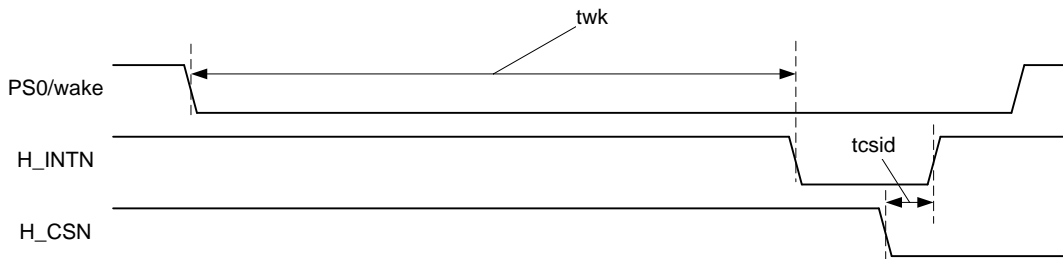

Figure 6-11: Host interrupt timing - SPI mode

Parameter	Symbol	Min	Typ	Max	Unit
I ² C address recognize to H_INTN dessert	tclid		10		μs
BNO08X wakeup from wake signal assert	twk		150		μs
H_CSN to H_INTN de-assert	tcsid		800		ns
H_INTN assert to UART transmission	tiatx		7.7		μs
H_INTN deassertion to H_INTN reassert	tidia	1			μs

Figure 6-12: H_INTN timing

In UART-SHTP mode the interrupt is asserted prior to the UART transmission. It is assumed that the host can always accept data over its UART. The interrupt is asserted approx. 7.7 μs prior to the first bit of UART transmission:

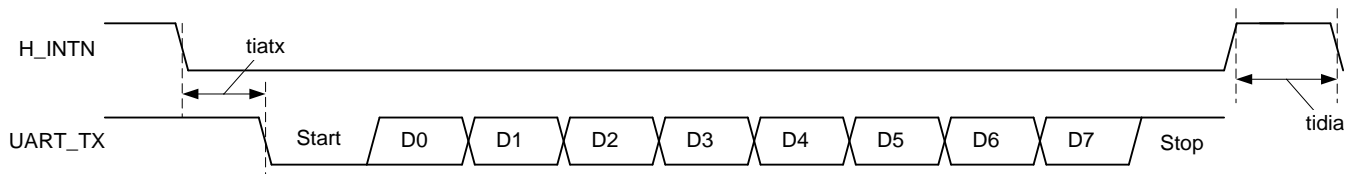

Figure 6-13: Host interrupt timing - UART-SHTP mode

The interrupt will be de-asserted prior to the termination of the UART transmission.

6.6 Mechanical Characteristics

The sensors within the BNO08X are specified by Bosch Sensortec. The mechanical and electrical details of the raw sensors are specified in the BMF055 datasheet [5].

The SH-2 software within the BNO08X configures the accelerometer for a range of +/- 8g and the gyroscope with a range of +/- 2000 °/s.

6.7 Performance Characteristics

The SH-2 software within the BNO08X calibrates and interprets the raw sensor data received from the gyroscope, accelerometer and magnetometer. By fusing the data from all three sensors the BNO08X can provide an estimate of the orientation of the device, the applied acceleration (i.e. gravity is removed from the accelerometer signal) and an estimate of gravity. Figure 6-14 captures the performance of the BNO08X when using an external clock or crystal.

Composite Sensor	Calibration	Measurement	Performance Metric	Value
Rotation Vector	Nominal	Dynamic	Rotation Error	3.5°
		Static	Rotation Error	2.0°
Gaming Rotation Vector	Nominal	Dynamic	Non-heading Error	2.5°
		Static	Non-heading Error	1.5°
		Dynamic	Heading Drift	0.5°/min
Geomagnetic Rotation Vector	Nominal	Dynamic	Rotation Error	4.5°
		Static	Rotation Error	3.0°
Gravity	Nominal	Static	Angle Error	1.5°
Linear Acceleration	Nominal	Dynamic	Accuracy	0.35 m/s ²
Accelerometer	Nominal	Dynamic	Accuracy	0.3 m/s ²
Gyroscope	Nominal	Dynamic	Accuracy	3.1°/s
Magnetometer	Either	Dynamic	Accuracy	1.4uT

Figure 6-14: BNO08X Performance

The results above were generated by simulation. 210 physical devices were characterized and each of these models was subjected to simulated motion and the variation from truth catalogued. The rotation vector and geomagnetic rotation vector are highly dependent on the environmental conditions (specifically the magnetic field). In practice the rotation vector is typically accurate to 5° and the geomagnetic rotation vector to 10°.

6.8 Latency

Latency is a measure of the response of the BNO08X to motion and is typically reserved for continuous sensors. The time to generate an output can be divided into several parameters:

- Sensor delay
- Processing delay
- Algorithmic delay
- Communication delay

The sensors within the BNO08X will generate an output reflecting motion or a measure of the magnetic field within the sample period just measured. The sensor interrupt is assumed to be the end of the sample.

The processing time of the BNO08X is dependent on the output of interest. The output for fused sensors (rotation vector, gravity etc.) follows a gyroscope sample and requires additional processing to fuse the gyroscope data with the accelerometer and magnetometer data.

Processing time is measured from data becoming available from the sensor to data being made available to the host (HOST_INTN asserted).

The algorithms present in SH-2 apply BW limiting filtering which in turn adds a small delay to the signal.

The communication delay is dependent upon the transfer speed of the communication medium chosen and the host's ability to respond to interrupts and support the maximum clock rate of the BNO08X.

The measured latency for the BNO08X is provided in Figure 6-13.

Sensor	Typical latency	
	100Hz	200Hz
Gyro rotation vector	6.6ms	3.7ms
Rotation vector	6.6ms	3.7ms
Game rotation vector	6.6ms	3.7ms

Figure 6-15: Typical latency measurements

6.9 Report Rates

The number of reports per second that the BNO08X can reliably deliver is dependent on the interface bandwidth and the processing time within the BNO08X for the generation of the data. The sensors also have discrete sample rates which must be taken into account when configuring the device. The BNO08X will attempt to satisfy the requested rate based on the following formula:

$$0.9 * \text{RequestedRate} \leq \text{ConfiguredRate} \leq 2.1 * \text{RequestedRate}$$

The maximum available data rates that can be configured per sensor are listed in Figure 6-16. Each individual sensor can operate at its maximum rate; however, all sensors cannot operate at their maximum rate simultaneously. For applications that require high sampling rates, the user will need to find a balance between which sensors to operate at a high rate and which sensor to operate at a low rate to find a configuration that meets their needs and fits within the interface bandwidth and processing power of the BNO08x.

Composite Sensor	Maximum Data rates (Hz)
Gyro rotation Vector	1000
Rotation Vector	400
Gaming Rotation Vector	400
Geomagnetic Rotation Vector	90
Gravity	400
Linear Acceleration	400
Accelerometer	500
Gyroscope	400
Magnetometer	100

Figure 6-16: Maximum sensor rates

Note that the AR/VR stabilized versions of the various rotation vectors have the same maximum report rates as their non-stabilized version.

6.10 Power Consumption

The power consumption of the BNO08X is dependent on the configuration of the device including the sample rates of various sensors and even the environment in which the device is being used. For example, an environment in which the magnetic field is constantly changing will require additional processing to resolve the current heading if a sensor that requires the magnetic field is configured. The tables below provide typical power consumption numbers for sample configurations using the SPI interface. Measurements are taken with VDDIO at 3V and VDD at 3.3V.

Sensor	Sensor Rate (Hz)	Current (mA)		Power (mW)
		VDDIO Rail	VDD Rail	
Idle Power	—	0.12	0.01	0.39
Android Sensors				
Gyro rotation Vector	1000	7.14	7.50	46.17
	400	7.10	7.50	46.05
6 and 9-Axis Sensor Fusion (Rotation Vector, Linear Acceleration, Gravity, Game Rotation Vector)	100	3.50	7.50	35.25
	200	5.34	7.50	40.77
	400	6.90	7.50	45.45
Calibrated Gyroscope	100	3.22	7.50	34.41
	200	4.83	7.50	39.24
	400	6.56	7.50	44.43
Geomagnetic Rotation Vector	100	2.51	4.70	23.04
Calibrated Accelerometer	125	1.23	0.15	4.19
	250	2.42	0.15	7.76
	500	4.81	0.15	14.93
Significant Motion Detector	31.25	0.40	0.14	1.66
Step counter/detector	31.25	0.42	0.14	1.72
CEVA Custom Sensors				
Tap detector	-	0.13	0.15	0.89
Shake gesture	31.25	0.32	0.14	1.42
Stability Classifier	100/62.5	2.85	7.50	33.30
Stability detector	31.25	0.12	0.01	0.39

Figure 6-17: Power consumption BNO085

Sensor	Sensor Rate (Hz)	Current (mA)		Power (mW)
		VDDIO Rail	VDD Rail	
Idle Power	—	0.047	0.01	0.17
Android Sensors				
Gyro rotation Vector	1000	6.84	7.50	45.27
	400	6.72	7.50	44.91
6 and 9-Axis Sensor Fusion (Rotation Vector, Linear Acceleration, Gravity, Game Rotation Vector)	100	3.18	7.50	34.29
	200	4.83	7.50	39.24
	400	6.55	7.50	44.40
Calibrated Gyroscope	100	2.92	7.50	33.51
	200	4.39	7.50	37.92
	400	6.32	7.50	43.71
Geomagnetic Rotation Vector	100	2.11	4.70	21.84
Calibrated Accelerometer	125	0.98	0.15	3.44
	250	1.93	0.15	6.29
	500	3.84	0.15	12.02
Significant Motion Detector	31.25	0.34	0.14	1.66
Step counter/detector	31.25	0.36	0.14	1.54
CEVA Custom Sensors				
Tap detector	-	0.05	0.15	0.65
Shake gesture	31.25	0.25	0.14	1.21
Stability Classifier	100/62.5	2.62	7.50	32.61
Stability detector	31.25	0.05	0.01	0.18

Figure 6-18: Power consumption BNO086

7.2 Landing Pattern Recommendation

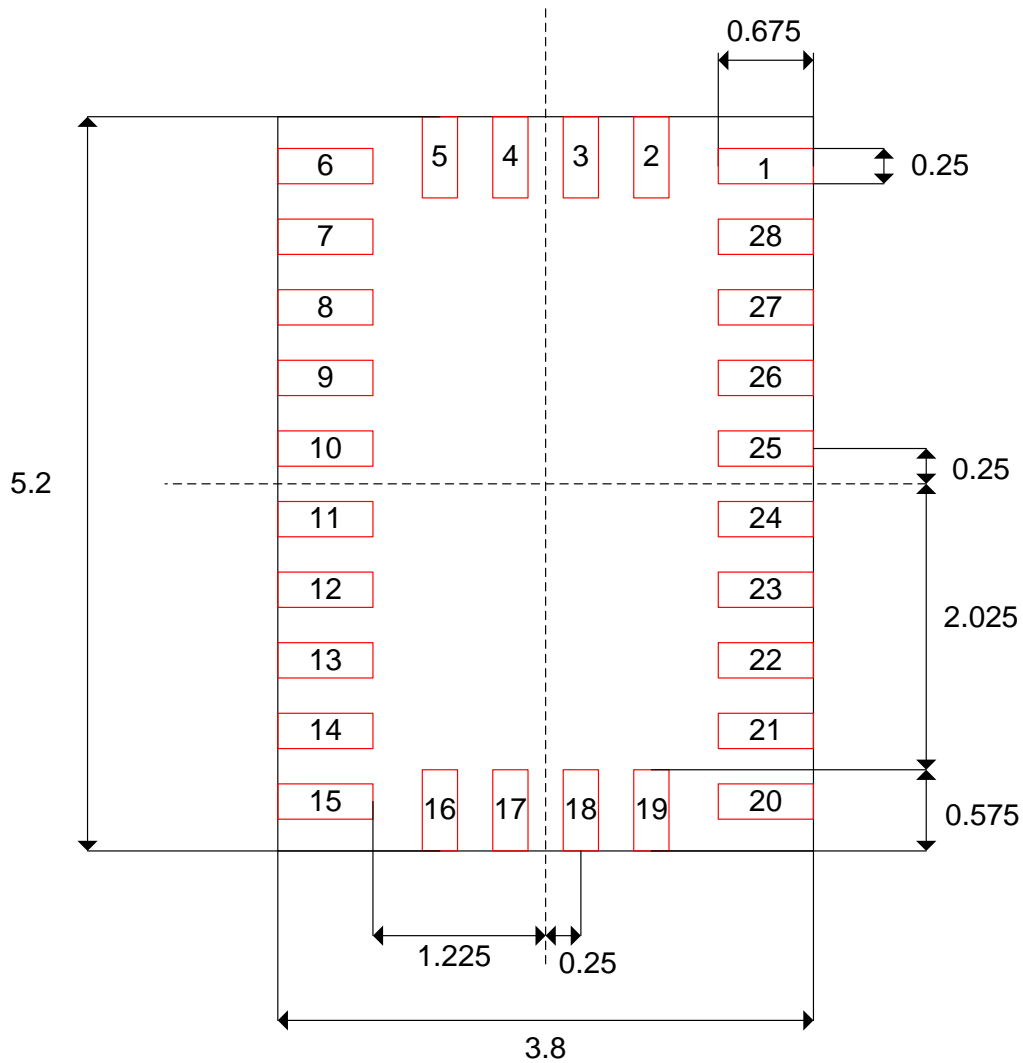

Figure 7-2: Landing pattern recommendation

7.3 Soldering Guidelines

Bosch Sensortec publishes a handling, soldering & mounting guide. The reader should consult that guide for manufacturing guidelines [5].

7.4 Marking

The reader should consult section 10 of the BMF055 datasheet for more information. For convenience, the part marking information has been reproduced in Figure 7-3.



Symbol	Name	Remark
•	Pin 1 identifier	—
701	Product number	3 numeric digits internal identification for product type
T	Second row	4-digits Internal use
C	Third row	3-digits Numerical counter

Figure 7-3: Marking of mass production parts

7.5 Soldering Guidelines

The moisture sensitivity level of the BNO08X sensors corresponds to JEDEC Level 1, see also

- IPC/JEDEC J-STD-020C "Joint Industry Standard: Moisture/Reflow Sensitivity Classification for non-hermetic Solid State Surface Mount Devices"
- IPC/JEDEC J-STD-033A "Joint Industry Standard: Handling, Packing, Shipping and Use of Moisture/Reflow Sensitive Surface Mount Devices"

The sensor fulfils the lead-free soldering requirements of the above-mentioned IPC/JEDEC standard, i.e. reflow soldering with a peak temperature up to 260°C.

7.6 Handling Instructions

Micromechanical sensors are designed to sense acceleration with high accuracy even at low amplitudes and contain highly sensitive structures inside the sensor element. The MEMS sensor can tolerate mechanical shocks up to several thousand g's. However, these limits might be exceeded in conditions with extreme shock loads such as e.g. hammer blow on or next to the sensor, dropping of the sensor onto hard surfaces etc.

We recommend avoiding g-forces beyond the specified limits during transport, handling and mounting of the sensors in a defined and qualified installation process.

This device has built-in protections against high electrostatic discharges or electric fields (e.g. 2kV HBM); however, anti-static precautions should be taken as for any other CMOS component. Unless otherwise specified, proper operation can only occur when all terminal voltages are kept within the supply voltage range. Unused inputs must always be tied to a defined logic voltage level.

For more details on recommended handling, soldering and mounting please contact CEVA and ask for the "Handling, soldering and mounting instructions" document [6].

7.7 Environmental Safety

The BNO08X sensor meets the requirements of the EC restriction of hazardous substances (RoHS and RoHS2) directive, see also:

- Directive 2002/95/EC of the European Parliament and of the Council of 27 January 2003 on the restriction of the use of certain hazardous substances in electrical and electronic equipment.

7.7.1 Halogen content

The BNO08X is halogen-free. For more details on the analysis results please contact CEVA.

8 Version History

Version	Changes	Date
1.17	Section 1.2.2: Removed note Section 1.2.2.2: Added polling behavior for BNO086	July 24, 2023
1.16	Removed referenced to BNO080	May 16, 2023
1.15	Update section 1.2.2 indicating that the BNO086 does not support I2C polling.	April 28, 2023
1.14	Added note about BNO080 being EOL	February 2, 2023
1.13	Further clarified I2C responses when polled in section 1.2.2.2.	January 12, 2023
1.12	Corrected feature list to indicate that certain features are present in both BNO085 and BNO086. Clarify BNO086 behavior in section 1.2.4.1. Clarify sensor operations in section 6.9. Clarified I2C responses when polled in section 1.2.2.2.	November 23, 2022
1.11	Update References section	June 10, 2021
1.10	Minor edits. Added MI and MR to section 1.2.5.2.	April 13, 2021
1.9	Clarify need to respond to H_INTN in section 1.2.4.1. Add BNO086 specific updates.	March 26, 2021
1.8	Updates to state that the internal clock may not be used with either of the UART interfaces. Add section 6.5.3 on startup timing. Add section 1.2.4.1 on H_INTN.	February 5, 2020
1.7	Remoted erroneous trademark in section 10	September 23, 2019
1.6	Removed CTS3 from section 3. Correct order of axes listed in section 4.1.1. Remove negative sign for Z-axis acceleration in section 1.2.5.2. Update capacitance loading for crystal in section 1.2.1.	April 30, 2019
1.5	Remove clutter from leftover change tracking. Revised section 1.1.3 to be more generally applicable.	January 24, 2018
1.4	Changes to cover BNO085	October 23, 2017
1.3	Update IO voltages in Figure 6-3. Update Figure 6-13	October 20, 2017
1.2	Added latency measurements. Clarified sequence number description. Clarified continuation bit in length field of SHTP header. Clarified SHTP channel usage. Added header to Figure 5-1. Update performance table. Clarified need to support clock stretching for I2C interface. Corrected descriptions in pin table for ENV_SCL and ENV_SDA.	May 19, 2017
1.1	Change VCC references to VDDIO. Minor editorial updates. Update references.	February 16, 2017

Version	Changes	Date
1.0	Initial release	February 2, 2017

9 References

The reference(s) listed with external links are up to date at time of the latest revision, but are subject to change without notice. Please [contact us](#) if you need assistance (both in finding a document and general inquiries).

1. 1000-3625 – SH-2 Reference Manual, CEVA.
2. 1000-3535 – Sensor Hub Transfer Protocol, CEVA.
3. Android Sensors HAL Overview, Google. (<http://source.android.com/devices/sensors/index.html>)
4. I²C-bus specification and user manual, NXP Semiconductors. (<https://www.nxp.com/docs/en/user-guide/UM10204.pdf>)
5. BMF055 datasheet, Bosch Sensortec. (<https://www.bosch-sensortec.com/media/boschsensortec/downloads/datasheets/bst-bmf055-ds000.pdf>)
6. BNO055 handling, soldering & mounting instructions. (https://www.bosch-sensortec.com/media/boschsensortec/downloads/handling_soldering_mounting_instructions/bst-bno055-hs000.pdf)
7. 1000-4044 – BNO08X Sensor Calibration Procedure, CEVA.
8. 1000-4045 – BNO08X Tare Function Usage Guide, CEVA.

10 Notices

© Copyright 2023 CEVA, Inc. and/or its subsidiaries (“CEVA”) All rights reserved. All specifications are subject to change without notice.

MotionEngine is a registered trademark of CEVA. Other company and product names mentioned in this document may be the trademark or registered trademark of their respective owners.

Disclaimer: The information furnished herein is believed to be accurate and reliable. However, the information is provided “AS IS”, without any express or implied warranty of any kind including warranties of merchantability, non-infringement of intellectual property, or fitness for any particular purpose.

In no event shall CEVA or its suppliers be liable for any claims and/or damages whatsoever arising out of the use of or inability to use the materials. CEVA and its suppliers further do not warrant the accuracy or completeness of the information, text, graphics or other items contained within these materials. CEVA may make changes to these materials, or to the products described within.

www.ceva-dsp.com





FOR MORE
INFORMATION:



Looking for pricing, stock, or lifecycle information?

Click below to explore more details on WIN SOURCE:

-  [View BNO080 on WIN SOURCE](#)
-  [CEVA Technologies, Inc. Information](#)

Optimize Your Supply Chain with WIN SOURCE Solutions

-  Global Sourcing Solution
-  Obsolete Management
-  Cost Control Management
-  Shortage Management
-  Alternative Solution
-  Excess Inventory Management