



THE DATASHEET OF
AL8863SP-13



Description

The AL8863 is a step-down DC/DC controller designed to drive LEDs with high output current. The device operates at an input supply voltage from 4.5V to 60V. Series connection of the LEDs provides identical LED currents resulting in uniform brightness and eliminating the need for ballast resistors. The switching frequency range of AL8863 is from 50kHz to 1MHz. The wide operating frequency range allows more flexibility on component selection, and also with operating up to 1MHz, it allows the use of smaller size external components, hence minimizing the PCB size and driver board.

The output current of AL8863 is set via an external resistor connected between the VIN and CSN input pins. Dimming is achieved by applying a PWM signal at the DIM input pin. The soft-start time can be adjusted using an external capacitor from the DIM pin to ground.

The AL8863 is available in the thermally enhanced SO-8EP package.

Features

- Wide Input Voltage Range: 4.5V to 60V
- Operating Frequency Range: 50kHz to 1MHz
- 1000:1 PWM Dimming Resolution at 100Hz
- Single Pin for On/Off and Brightness Control by PWM Signal
- Fault Status Indication for Abnormal Operation
- LED Shorted Protection
- Inherent Open-Circuit LED Protection
- Programmable Thermal Fold-Back Operation Through NTC Pin
- Over Temperature Shutdown
- Thermally Enhanced SO-8EP Package
- **Totally Lead-Free & Fully RoHS Compliant (Notes 1 & 2)**
- **Halogen and Antimony Free. "Green" Device (Note 3)**

- Notes:
1. No purposely added lead. Fully EU Directive 2002/95/EC (RoHS), 2011/65/EU (RoHS 2) & 2015/863/EU (RoHS 3) compliant.
 2. See <https://www.diodes.com/quality/lead-free/> for more information about Diodes Incorporated's definitions of Halogen- and Antimony-free, "Green" and Lead-free.
 3. Halogen- and Antimony-free "Green" products are defined as those which contain <900ppm bromine, <900ppm chlorine (<1500ppm total Br + Cl) and <1000ppm antimony compounds.

Pin Assignments

(Top View)

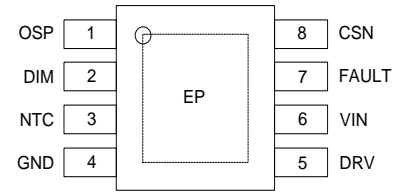

SO-8EP

Applications

- Commercial & Industrial Lighting
- Architecture Lighting
- External LED Drivers and Smart Lighting

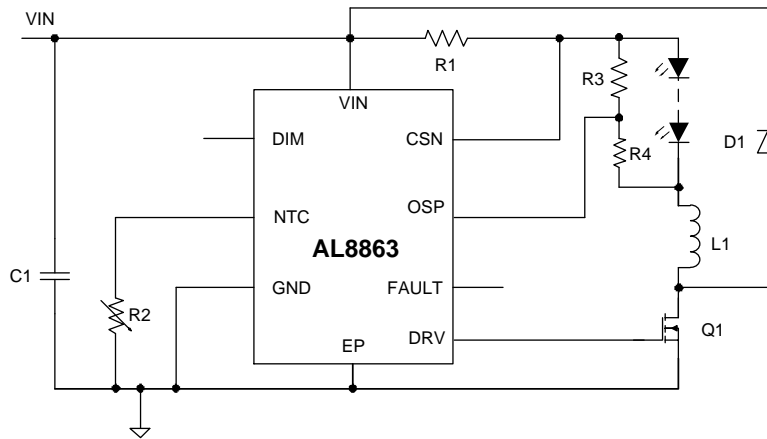
Typical Applications Circuit

Pin Descriptions

Pin Number	Pin Name	Function
1	OSP	Output Shorted Protection
2	DIM	Multi-function On/Off and brightness control pin: <ul style="list-style-type: none"> • Leave floating for normal operation • Drive to voltage below 0.3V to turn off output current • Drive with an analog voltage >2.6V, output current will be 100% of I_{OUT_NOM} • A PWM signal (Low level <0.3V, High level >2.6V, transition time less than 1μs) allows the output current to be adjusted over a wide range up to 100% • Connect a capacitor from this pin to ground to increase soft-start time
3	NTC	Connect a NTC resistor to GND to set thermal fold-back break point
4	GND	Ground
5	DRV	Gate Driver
6	VIN	Input voltage (4.5V to 60V). Decouple to ground with 10μF or higher X7R ceramic capacitor close to device.
7	FAULT	Fault Report Pin. Asserted Low to report faulty conditions. Needs an external pull-up resistor.
8	CSN	Current sense negative input. Connect current sense resistor from VIN to CSN for high-side current sense control
9	EP	Exposed pad. Connect to GND and thermal mass for enhanced thermal impedance. Should not be used as electrical ground conduction path.

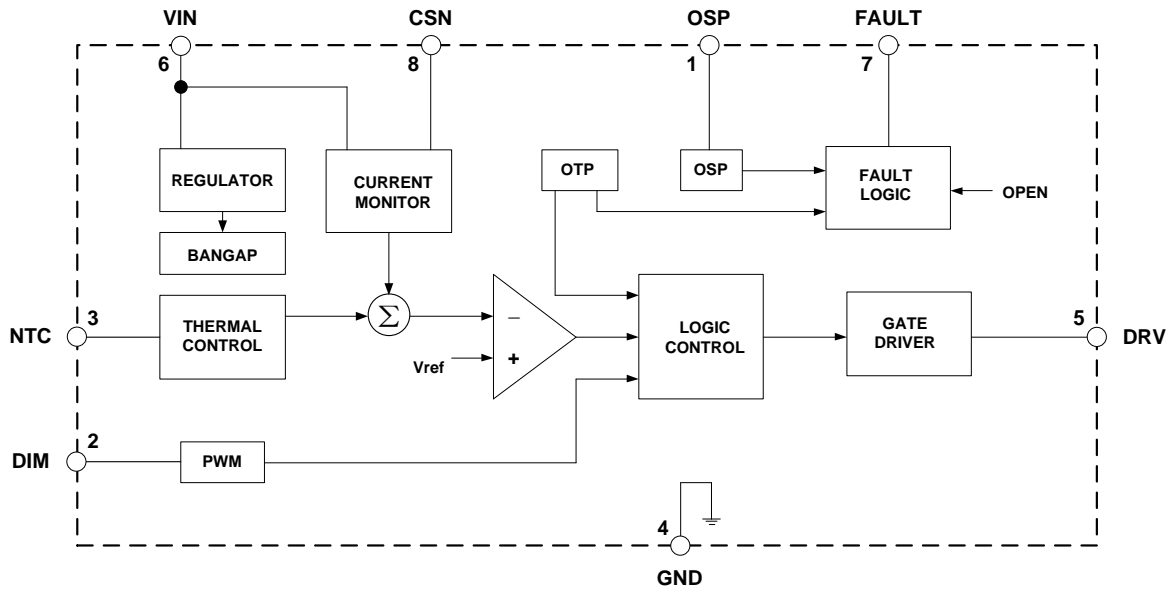
Functional Block Diagram



Absolute Maximum Ratings (Note 4)

Symbol	Parameter	Rating	Unit
V_{IN}	Input Voltage	-0.3 to +65	V
$V_{CSN}, V_{FAULT}, V_{OSP}$	CSN, FAULT, OSP Pin Voltage	-0.3 to +65	V
V_{DRV}	DRV Pin Voltage	-0.3 to +20	V
V_{DIM}, V_{NTC}	DIM, NTC Pin Voltage	-0.3 to +5.5	V
T_J	Operating Junction Temperature	-40 to +150	°C
T_{STG}	Storage Temperature Range	-65 to +165	°C

Note: 4. Stresses greater than those listed under “Absolute Maximum Ratings” can cause permanent damage to the device. These are stress ratings only, and functional operation of the device at these or any other conditions beyond those indicated under “Recommended Operating Conditions” is not implied. Exposure to “Absolute Maximum Ratings” for extended periods can affect device reliability.

ESD Ratings

Symbol	Parameter	Rating	Unit
V_{ESD}	Human-Body Model (HBM)	±2000	V
	Charged-Device Model (CDM)	±750	

Recommended Operating Conditions

Symbol	Parameter	Min	Max	Unit
V_{IN}	Input Voltage	4.5	60	V
f_{SW}	Operating Frequency	50	1000	kHz
T_A	Operating Ambient Temperature	-40	+125	°C

Thermal Information (Note 5)

Symbol	Parameter	Rating	Unit
θ_{JA}	Junction-to-Ambient Thermal Resistance	56	°C/W
θ_{JC}	Junction-to-Case(Top) Thermal Resistance	6	°C/W

Note: 5. Device mounted on 2"×2" FR-4 substrate PC board, 2oz copper, with minimum recommended pad on top layer and thermal vias to bottom layer ground plane.

Electrical Characteristics ($T_A = +25^\circ\text{C}$, $V_{IN} = 12\text{V}$, unless otherwise specified.)

Symbol	Parameter	Conditions	Min	Typ	Max	Unit
INPUT VOLTAGE (VIN)						
V_{IN}	Input Voltage	—	4.5	—	60	V
UVLO	VIN UVLO Rising Threshold	—	—	4.3	—	V
UVLO_HYS	VIN UVLO Hysteresis	—	—	150	—	mV
I_Q	Quiescent Current	DIM pin floating	—	600	—	μA
CURRENT REGULATION (VIN, CSN)						
V_{SENSE}	Mean Current Sense Threshold Voltage	Measured on CSN Pin with Respect to VIN	95	100	105	mV
V_{SENSE_HYS}	Sense Threshold Hysteresis	—	—	±13	—	mV
I_{CSN}	CSN Pin Input Current	$V_{CSN} = V_{IN} - 0.1$	—	16	—	μA
GATE DRIVER (DRV)						
V_{GATE_HIGH}	Gate Driver Output Voltage High	$V_{IN} = 12\text{V}$, Sourcing 20mA	9	—	—	V
V_{GATE_LOW}	Gate Driver Output Voltage Low	$V_{IN} = 12\text{V}$, Sinking 20mA	—	—	0.5	V
V_{GATE_CLAMP}	Gate Driver Clamp Voltage	$V_{IN} = 18\text{V}$, Sourcing 20mA	—	—	15	V
t_{RISE}	Gate Driver Rising Time	$V_{IN} = 13\text{V}$, C = 10nF	—	100	—	ns
t_{FALL}	Gate Driver Falling Time	$V_{IN} = 13\text{V}$, C = 10nF	—	60	—	ns
R_{GH}	Gate Driver High Side Resistance	$I_{DRV} = -20\text{mA}$	—	5.7	—	Ω
R_{GL}	Gate Driver Low Side Resistance	$I_{DRV} = 20\text{mA}$	—	2.2	—	Ω
PWM DIMMING (DIM)						
f_{PWM}	Recommended PWM Dimming Frequency	—	0.1	—	20	kHz
V_{DIM_HIGH}	DIM Logic High Level	—	2.6	—	5.5	V
V_{DIM_LOW}	DIM Logic Low Level	—	—	—	0.3	V
SWITCHING OPERATION						
f_{SW_MAX}	Recommended Maximum Switching Frequency	—	—	—	1	MHz
t_{ON_REC}	Recommended Minimum Switch ON Time	For 4% Accuracy	—	500	—	ns
t_{PD}	Internal Comparator Propagation Delay	—	—	100	—	ns
OUTPUT SHORTED PROTECTION (CSN, OSP)						
$V_{(CSN-OSP)}$	Output Short Threshold Voltage	—	—	1	—	V
t_D	Delay Time for Fault Detection	—	—	23	—	ms
FAULT FLAG (FAULT)						
V_{FAULT_LOW}	FAULT Output Low Voltage	$I_{FAULT} = 1\text{mA}$	—	—	700	mV
THERMAL FOLD-BACK (NTC)						
V_{NTC_HIGH}	NTC Upper Threshold Voltage	Thermal fold-back starts	—	1.3	—	V
V_{NTC_LOWER}	NTC Lower Threshold Voltage	Thermal fold-back stops	—	1	—	V
I_{BIAS}	NTC Internal Bias Current	—	95	100	105	μA
THERMAL SHUTDOWN						
T_{TSD}	Thermal Shutdown Threshold	—	—	+165	—	°C
T_{TSD_HYS}	Thermal Shutdown Hysteresis	—	—	+30	—	°C

Typical Performance Characteristics ($T_A = +25^\circ\text{C}$, $V_{IN} = 12\text{V}$, unless otherwise noted).

NEW PRODUCT

Quiescent Current vs. Input Voltage

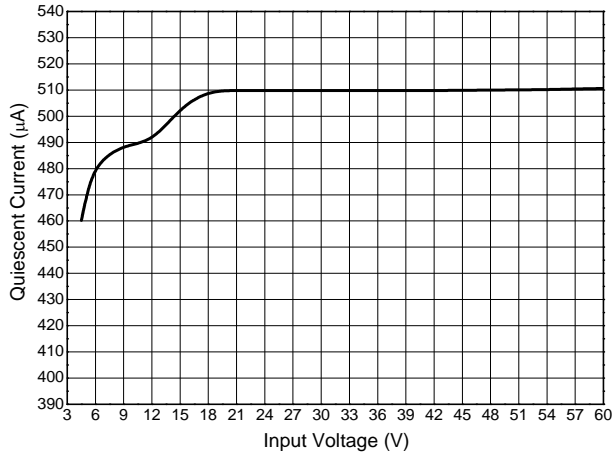

Quiescent Current vs. Temperature

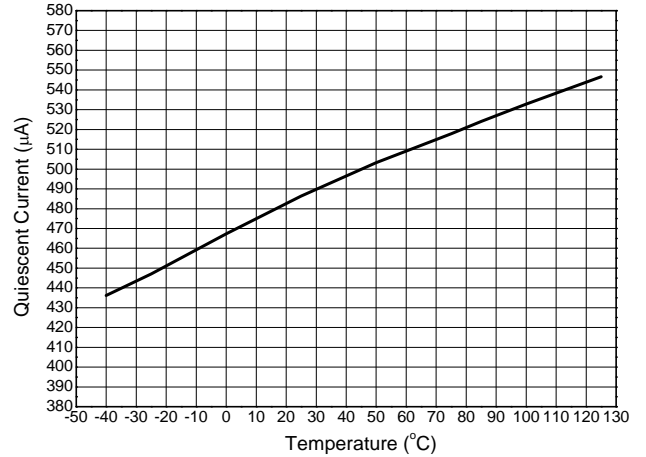

Sense Threshold Voltage vs. Input voltage

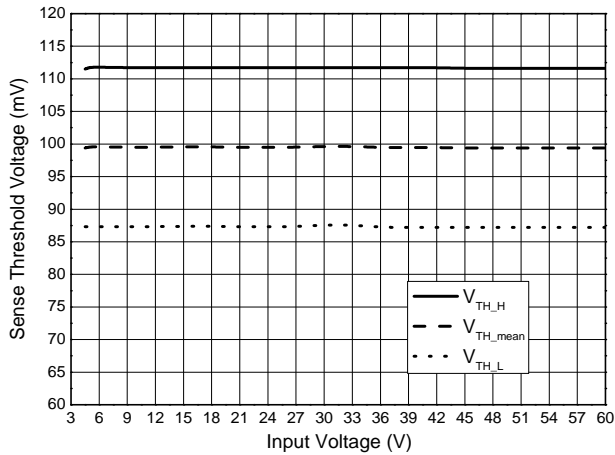

Sense Threshold Voltage vs. Temperature

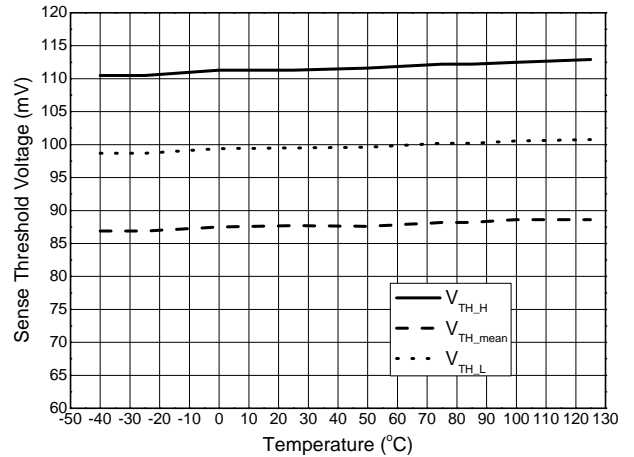

NTC Bias Current vs. Input Voltage

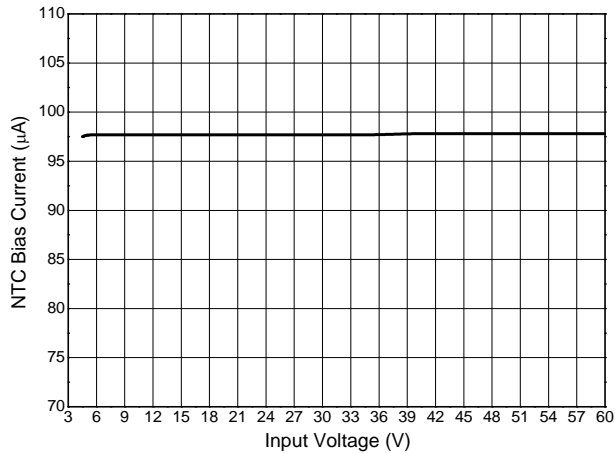

NTC Bias Current vs. Temperature

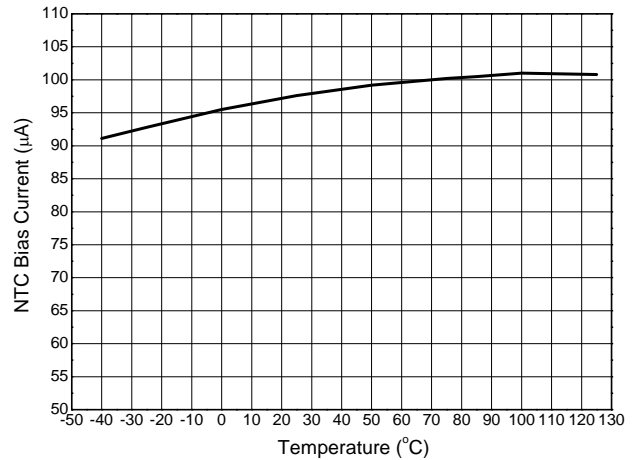

Typical Performance Characteristics (continued) ($T_A = +25^\circ\text{C}$, $V_{IN} = 12\text{V}$, unless otherwise noted).

Output Short Threshold Voltage vs. Input Voltage

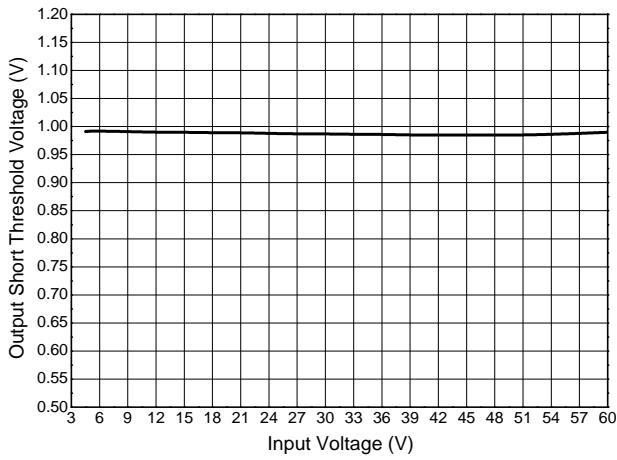

Output Short Threshold Voltage vs. Temperature

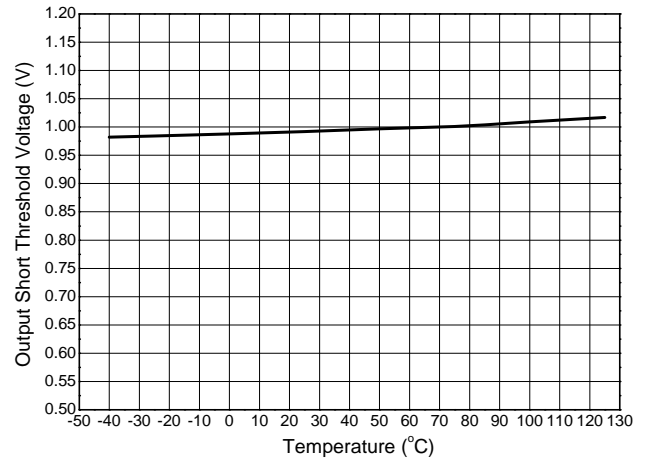

**PWM Dimming ($V_{IN} = 40\text{V}$, 6LEDs, $47\mu\text{H}$, $R_S = 0.033\Omega$)
Output Current vs. Duty Cycle**

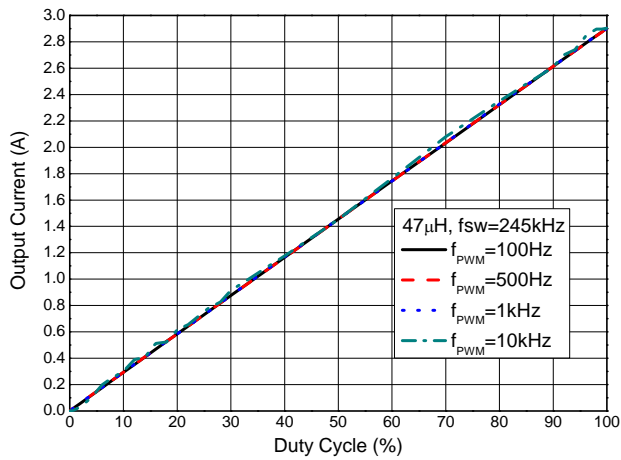

**Thermal Fold-Back ($V_{IN} = 40\text{V}$, 6LEDs, $47\mu\text{H}$, $R_S = 0.033\Omega$)
Output Current vs. NTC Pin Voltage**

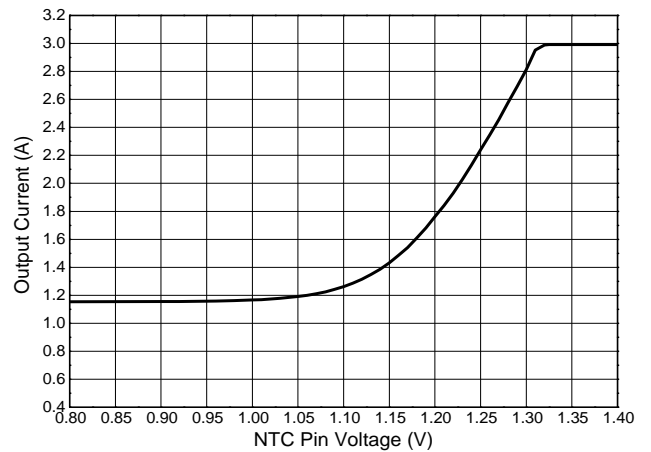

NEW PRODUCT

Application Information

The AL8863 is a hysteretic mode step-down LED controller and is available in thermal enhanced SO-8EP package.

AL8863 Operation

In normal operation, when normal input voltage is applied at VIN, the DRV outputs high and output switch Q1 is turned on. Current starts to flow through sense resistor R1, LEDs, inductor L1 and output switch Q1. The current ramps up linearly, and the ramp-up rate is determined by the input voltage VIN, VOUT and the inductor L1.

This rising current produces a voltage ramp across R1. The internal circuit of the AL8863 senses the voltage across R1 and applies a proportional voltage to the input of the internal comparator. When this voltage reaches an internally set upper threshold, the DRV outputs low and output switch Q1 is turned off. The inductor current continues to flow through R1, LEDs, L1 and diode D1, and back to the supply rail, but it decays, with the rate determined by the forward voltage drop of LEDs and the diode D1.

This decaying current produces a falling voltage on R1, which is sensed by the AL8863. A voltage proportional to the sense voltage across R1 will be applied at the input of internal comparator. When this voltage falls to the internally set lower threshold, the DRV outputs high and output switch Q1 is turned on again.

This switch-on-and-off cycle continues to provide the average LED current set by the sense resistor R1.

LED Current Configuration

The nominal average output current in the LED(s) is determined by the value of the external current sense resistor (RSET) connected between VIN pin and CSN pin, according to:

$$I_{OUT(NOM)} = \frac{0.1}{R_{SET}}$$

The table below gives values of nominal average output current for several preferred values of current setting resistor (RSET) in the *Typical Application Circuit* shown on page 2.

RSET (Ω)	Nominal Average Output Current (mA)
0.1	1000
0.033	3000
0.02	5000

The above values assume that the DIM pin is floating and at a nominal reference voltage for internal comparator.

PWM Dimming

LED current can be adjusted digitally, by applying a low frequency pulse-width-modulated (PWM) logic signal to the DIM pin to turn the device on and off. This will produce an average output current proportional to the duty cycle of the PWM signal. To achieve a high resolution, the PWM frequency is recommended to be lower than 500Hz, however higher dimming frequencies can be used, at the expense of dimming dynamic range and accuracy. Typically, for a PWM frequency of 500Hz the accuracy is better than 1% for PWM ranging from 1% to 100%.

The accuracy of the low duty cycle dimming is affected by both the PWM frequency and also the switching frequency of the AL8863. For best accuracy/resolution the switching frequency should be increased while the PWM frequency should be reduced.

The DIM pin is designed to be driven by both 3.3V and 5V logic levels directly from a logic output with either an open drain output or push pull output stage.

Soft Start

The AL8863 does not have in-built soft-start action – this provides very fast turn on of the output, improving PWM dimming accuracy.

Nevertheless, adding an external capacitor from the DIM pin to ground will provide a soft-start delay. This is achieved by increasing the time for the DIM voltage rising to the turn-on threshold and by slowing down the rising rate of the control voltage at the input of hysteresis comparator. The additional soft start time is related to the capacitance between DIM and GND, and the typical value will be approximately 0.06ms/nF.

Application Information (continued)

LED Open-Circuit Protection

The AL8863 has by default open LED protection. If the LEDs should become open circuit, the resulted voltage drop on sensing resistor is nearly zero and the DRV pin output will be constantly high, leading to output voltage V_{OUT} equals V_{IN} . No excessive voltages will be seen by the AL8863 and external components. If open circuit condition lasts for continuous $416\mu s$, FAULT goes low. Once open circuit condition is removed, the AL8863 resumes normal operation and FAULT resumes high.

For PWM dimming operation, ensure at least one switching cycle during each PWM cycle to make FAULT detection correct. FAULT goes low after open circuit condition lasts for accumulated $416\mu s$ during on time of PWM cycles.

LED Short-Circuit Protection

If the LED string should become shorted together (the anode of the top LED becomes shorted to the cathode of the bottom LED), the AL8863 will continue to switch and the output current will still be at the regulated current - so no damages will be caused within the AL8863 and external components. However, the duty cycle at which it operates will change dramatically and the switching frequency will most likely decrease.

The AL8863 includes a dedicated OSP pin, used in combination with CSN pin for LED short circuit fault detection. A resistor divider is set up between CSN node (the anode of LED string) to the cathode of LED string, and the CSN pin and OSP pin senses output voltage. When the differential voltage between CSN and OSP is continuously below 1V for 23ms, FAULT goes low. Once short circuit condition is removed, the AL8863 resumes normal operation and FAULT resumes high.

For PWM dimming operation, ensure at least one switching cycle during each PWM cycle to make FAULT detection correct. FAULT goes low when the differential voltage between CSN and OSP is continuously below 1V for 23ms.

Over-Temperature Protection

The AL8863 includes Over-Temperature Protection (OTP) circuitry to protect the device from excessive heat damage. When the junction temperature exceeds approximately $+165^{\circ}C$, the AL8863 is forced to shutdown and FAULT goes low. Once the junction temperature cools down by approximately $+40^{\circ}C$, the AL8863 automatically restarts and FAULT resumes high.

Thermal Fold-Back Operation

The AL8863 includes a programmable thermal fold-back feature to reduce power dissipation at high ambient temperature. An external NTC thermistor can be connected from NTC pin to GND as shown below. The NTC bias current is $100\mu A$, flowing across the NTC thermistor and generating a voltage on the NTC pin. The AL8863 monitors the voltage on the NTC pin and reduces output current if the voltage on this pin falls below 1.3V. The value of NTC thermistor can be adjusted to set the voltage on the NTC pin to 1.3V at the required temperature threshold T_{break} . The output current is gradually reduced to 35% of its nominal value until the voltage on the NTC pin falls below 1V if the temperature continues to rise.

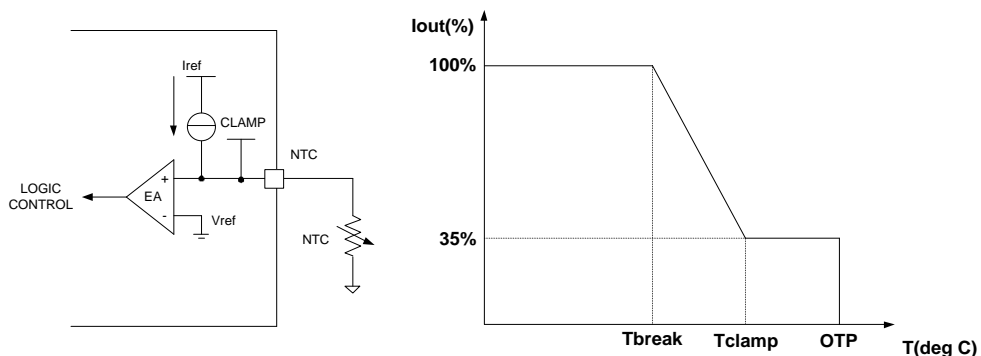

Fault Indicator (FAULT)

The AL8863 includes an active low, open-drain Fault indicator (FAULT). The FAULT pin goes low when one of the following conditions occurs:

- (1) Open circuit across the LED string
- (2) Short circuit across the LED string
- (3) Over-temperature condition

Application Information (continued)

The following table summarizes the device behavior under fault condition.

FAULT	Detection	Action
Open-circuit across LED string	DRV high lasts for accumulated 416μs	<p>When open circuit occurs, the resulted voltage drop on sensing resistor is nearly zero and the DRV pin output will be constantly high, leading to output voltage VOUT equals VIN. No excessive voltages will be seen by the AL8863 and external components.</p> <p>If open circuit condition lasts for accumulated 416μs, FAULT goes low. The AL8863 resumes normal operation and FAULT resumes high once fault condition is removed.</p> <p>Note: for PWM dimming operation, ensure at least one switching cycle during each PWM cycle to make FAULT detection correct.</p>
Short-circuit across LED string	$V_{(CSN-OSP)} < 1V$ lasts for 23ms	<p>When short circuit occurs, the AL8863 will continue to switch and the output current will still be at the regulated current, no damages will be caused. The duty cycle at which it operates will change dramatically and the switching frequency will most likely decrease.</p> <p>If $V_{(CSN-OSP)} < 1V$ lasts for continuous 23ms, FAULT goes low. The AL8863 resumes normal operation and FAULT resumes high once fault condition is removed.</p> <p>Note: for PWM dimming operation, ensure at least one switching cycle during each PWM cycle to make FAULT detection correct.</p>
Over-temperature condition	$T_J > +165^{\circ}C$	<p>When the junction temperature exceeds approximately +165°C, the AL8863 is forced to shutdown and FAULT goes low. A start up sequence is initiated and FAULT resumes high when the junction temperature drops by +40°C.</p>

Ordering Information

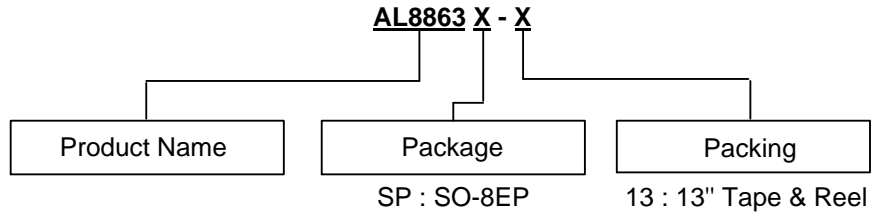

Part Number	Package Code	Package	Tape and Reel	
			Quantity	Part Number Suffix
AL8863SP-13	SP	SO-8EP	2500/Tape & Reel	-13

Marking Information

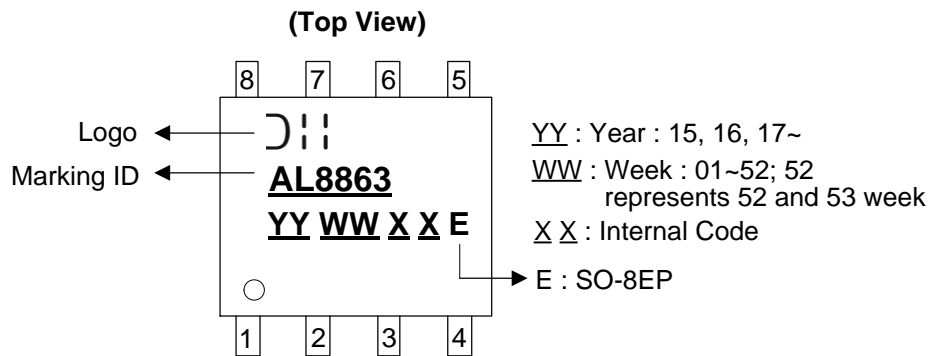

NEW PRODUCT

Package Outline Dimensions (All dimensions in mm.)

(1) Package Type: SO-8EP

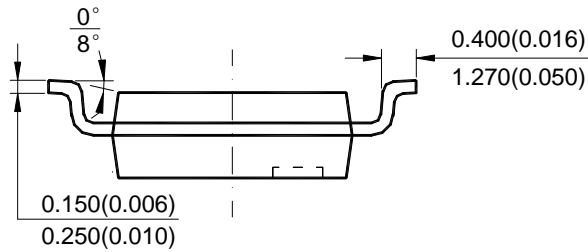
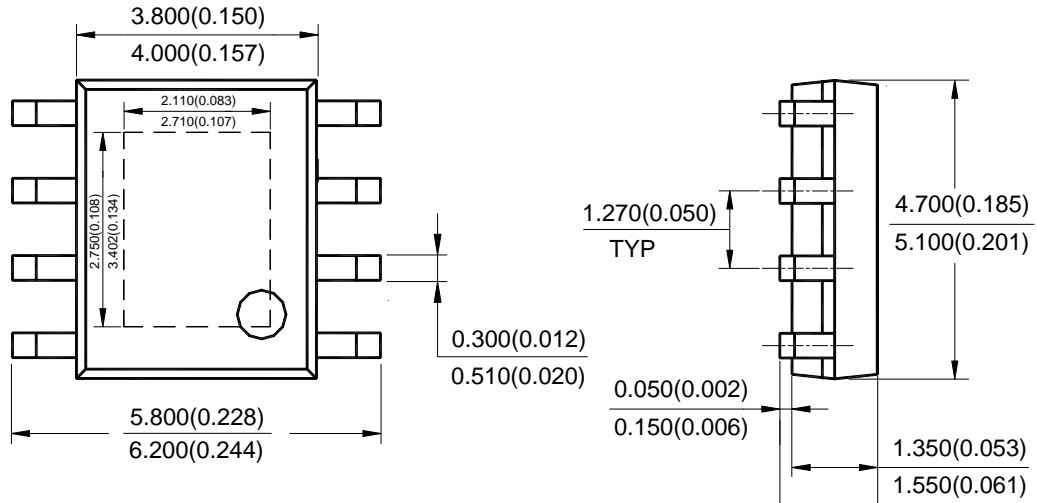

Note: Eject hole, oriented hole and mold mark is optional.

NEW PRODUCT

Suggested Pad Layout

(1) Package Type: SO-8EP

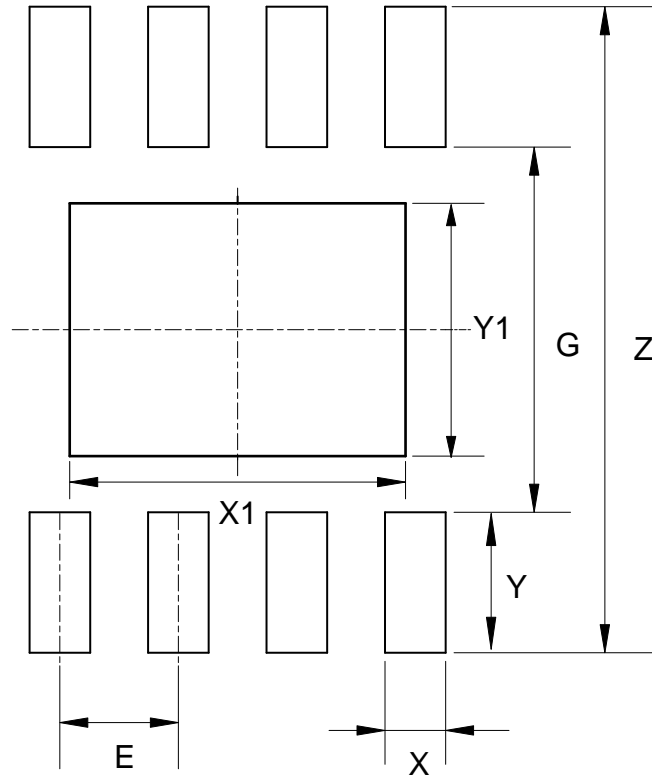

Dimensions	Z (mm)/(inch)	G (mm)/(inch)	X (mm)/(inch)	Y (mm)/(inch)	X1 (mm)/(inch)	Y1 (mm)/(inch)	E (mm)/(inch)
Value	6.900/0.272	3.900/0.154	0.650/0.026	1.500/0.059	3.600/0.142	2.700/0.106	1.270/0.050

IMPORTANT NOTICE

DIODES INCORPORATED MAKES NO WARRANTY OF ANY KIND, EXPRESS OR IMPLIED, WITH REGARDS TO THIS DOCUMENT, INCLUDING, BUT NOT LIMITED TO, THE IMPLIED WARRANTIES OF MERCHANTABILITY AND FITNESS FOR A PARTICULAR PURPOSE (AND THEIR EQUIVALENTS UNDER THE LAWS OF ANY JURISDICTION).

Diodes Incorporated and its subsidiaries reserve the right to make modifications, enhancements, improvements, corrections or other changes without further notice to this document and any product described herein. Diodes Incorporated does not assume any liability arising out of the application or use of this document or any product described herein; neither does Diodes Incorporated convey any license under its patent or trademark rights, nor the rights of others. Any Customer or user of this document or products described herein in such applications shall assume all risks of such use and will agree to hold Diodes Incorporated and all the companies whose products are represented on Diodes Incorporated website, harmless against all damages.

Diodes Incorporated does not warrant or accept any liability whatsoever in respect of any products purchased through unauthorized sales channel. Should Customers purchase or use Diodes Incorporated products for any unintended or unauthorized application, Customers shall indemnify and hold Diodes Incorporated and its representatives harmless against all claims, damages, expenses, and attorney fees arising out of, directly or indirectly, any claim of personal injury or death associated with such unintended or unauthorized application.

Products described herein may be covered by one or more United States, international or foreign patents pending. Product names and markings noted herein may also be covered by one or more United States, international or foreign trademarks.

This document is written in English but may be translated into multiple languages for reference. Only the English version of this document is the final and determinative format released by Diodes Incorporated.

LIFE SUPPORT

Diodes Incorporated products are specifically not authorized for use as critical components in life support devices or systems without the express written approval of the Chief Executive Officer of Diodes Incorporated. As used herein:

A. Life support devices or systems are devices or systems which:

1. are intended to implant into the body, or
2. support or sustain life and whose failure to perform when properly used in accordance with instructions for use provided in the labeling can be reasonably expected to result in significant injury to the user.

B. A critical component is any component in a life support device or system whose failure to perform can be reasonably expected to cause the failure of the life support device or to affect its safety or effectiveness.

Customers represent that they have all necessary expertise in the safety and regulatory ramifications of their life support devices or systems, and acknowledge and agree that they are solely responsible for all legal, regulatory and safety-related requirements concerning their products and any use of Diodes Incorporated products in such safety-critical, life support devices or systems, notwithstanding any devices- or systems-related information or support that may be provided by Diodes Incorporated. Further, Customers must fully indemnify Diodes Incorporated and its representatives against any damages arising out of the use of Diodes Incorporated products in such safety-critical, life support devices or systems.

Copyright © 2019, Diodes Incorporated

www.diodes.com

Looking for pricing, stock, or lifecycle information?

Click below to explore more details on WIN SOURCE:

 [View AL8863SP-13 on WIN SOURCE](#)

 [Diodes Incorporated](#) Information

Optimize Your Supply Chain with WIN SOURCE Solutions

-  Global Sourcing Solution
-  Obsolete Management
-  Cost Control Management
-  Shortage Management
-  Alternative Solution
-  Excess Inventory Management