



**THE DATASHEET OF
NCV7357MW0R2G**



CAN FD Transceiver, High Speed

NCV7357

Description

The NCV7357 CAN FD transceiver is the interface between a controller area network (CAN) protocol controller and the physical bus. The transceiver provides differential transmit capability to the bus and differential receive capability to the CAN controller.

The NCV7357 is an addition to the CAN high-speed transceiver family complementing NCV7344 CAN stand-alone transceivers and previous generations such as AMIS42665, AMIS3066x, etc.

The NCV7357 guarantees additional timing parameters to ensure robust communication at data rates beyond 1 Mbps to cope with CAN flexible data rate requirements (CAN FD). These features make the NCV7357 an excellent choice for all types of HS-CAN networks, in nodes that require only a basic CAN capability.

Features

- Compliant with ISO 11898-2:2016
- CAN FD Timing Specified up to 5 Mbps
- V_{IO} Pin on NCV7357-3 Version Allowing Direct Interfacing with 3 V to 5 V Microcontrollers
- Low Current, Listen Only Silent Mode
- Low Electromagnetic Emission (EME) and High Electromagnetic Immunity
- Very Low EME without Common-mode (CM) Choke
- No Disturbance of the Bus Lines with an Unpowered Node
- Transmit Data (TxD) Dominant Timeout Function
- Under All Supply Conditions the Chip Behaves Predictably
- Very High ESD Robustness of Bus Pins, >8 kV System ESD Pulses
- Thermal Protection
- Bus Pins Short Circuit Proof to Supply Voltage and Ground
- Bus Pins Protected Against Transients in an Automotive Environment
- These are Pb-free Devices

Quality

- Wettable Flank Package for Enhanced Optical Inspection
- AEC-Q100 Grade 0 Qualified and PPAP Capable

Typical Applications

- Automotive
- Industrial Networks

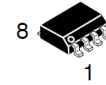

SOIC-8
D SUFFIX
CASE 751-07



DFNW8
MW SUFFIX
CASE 507AB

MARKING DIAGRAM



NV7357-X = Specific Device Code
 A = Assembly Location
 L = Wafer Lot
 Y = Year
 W = Work Week
 ■ = Pb-Free Package

PIN ASSIGNMENT

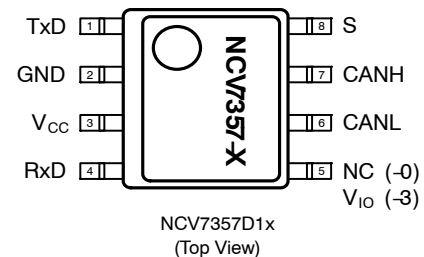
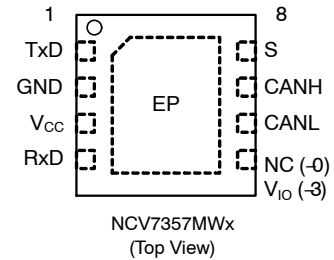

ORDERING INFORMATION

See detailed ordering, marking and shipping information on page 11 of this data sheet.

NCV7357

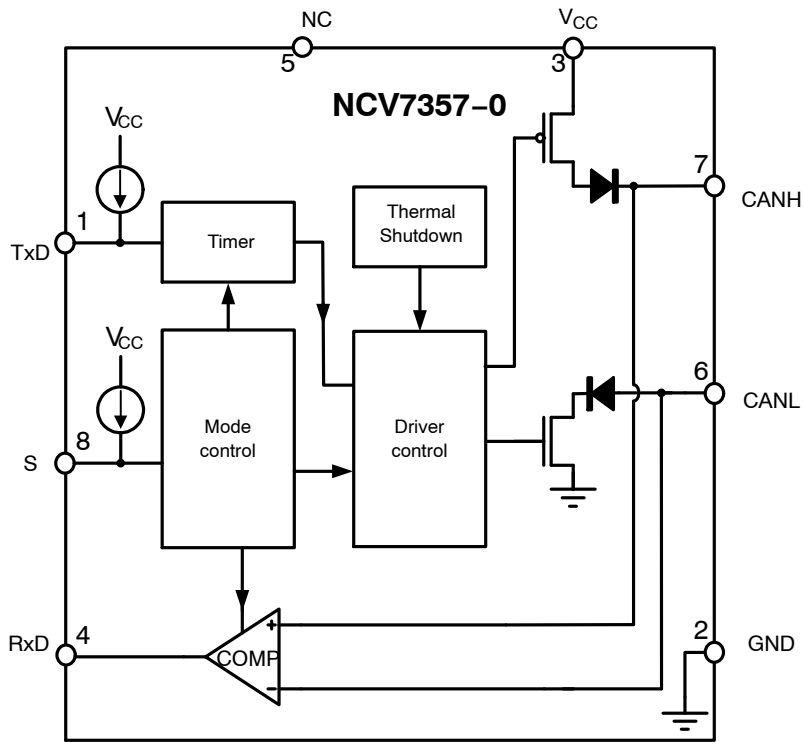

Figure 1. NCV7357-0 Block Diagram

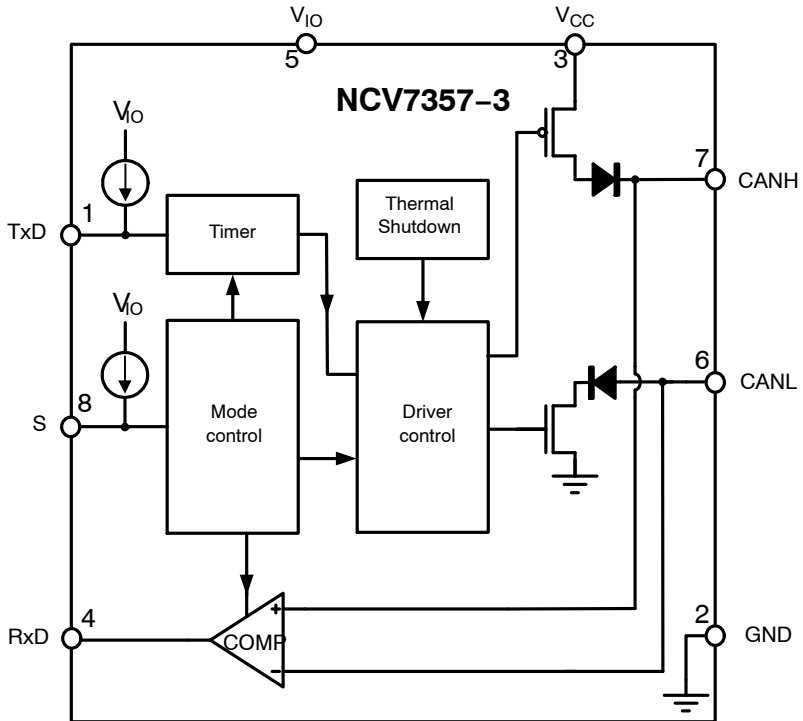

Figure 2. NCV7357-3 Block Diagram

NCV7357

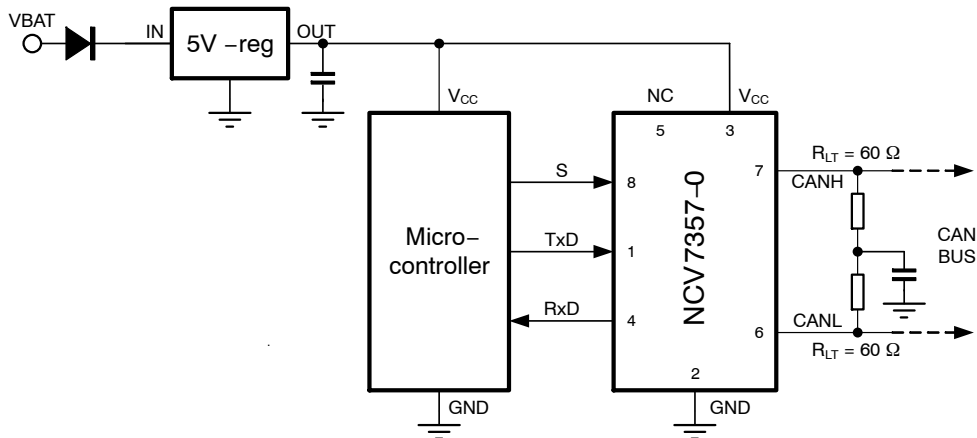

Figure 3. Application Diagram NCV7357-0

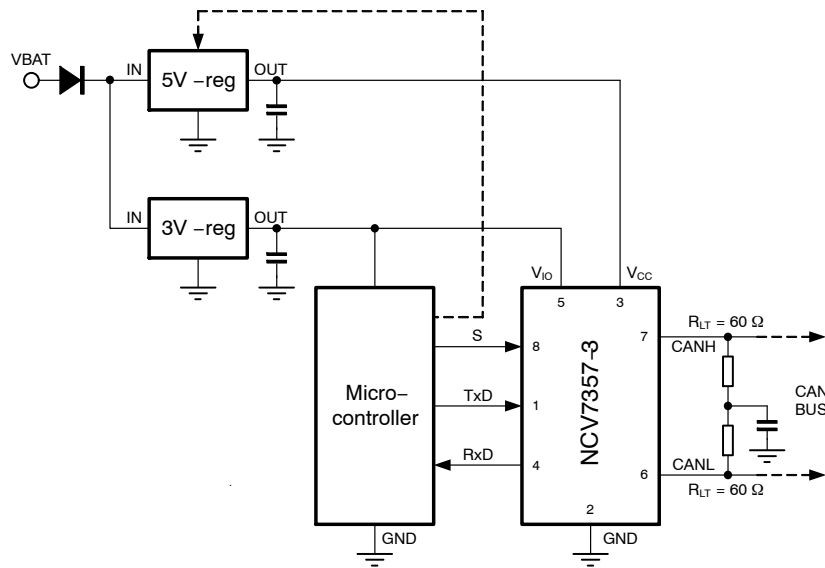

Figure 4. Application Diagram NCV7357-3

Table 1. PIN FUNCTION DESCRIPTION

Pin	Name	Description
1	TxD	Transmit data input; low input → dominant driver; internal pull-up current
2	GND	Ground
3	V _{CC}	Supply voltage
4	RxD	Receive data output; dominant transmitter → low output
5	NC	Not connected. On NCV7357-0 only
5	V _{IO}	Digital Input / Output pins supply voltage. On NCV7357-3 only
6	CANL	Low-level CAN bus line (low in dominant mode)
7	CANH	High-level CAN bus line (high in dominant mode)
8	S	Silent mode control input; internal pull-up current
	EP	Exposed Pad. Recommended to connect to GND or left floating in application (DFNW8 package only).

FUNCTIONAL DESCRIPTION

High speed CAN FD transceiver

NCV7357 implements high-speed physical layer CAN FD transceiver compatible with ISO11898-2, implementing following optional features or alternatives:

- Extended bus load range

- Transmit dominant timeout, long
- Support of bit rates up to 5 Mbps
- Normal Bus biasing

Operating Modes

NCV7357 provides two modes of operation as illustrated in Table 2. These modes are selectable through pin S.

Table 2. OPERATING MODES

Pin S	Mode	Pin TxD	BUS	Pin RxD
Low	Normal	0	Dominant	0
		1	Recessive	1
High	Silent	X	Dominant (1)	0
		X	Recessive	1

1. CAN BUS driven by another transceiver on the BUS
2. 'X' = don't care

Power-off

This virtual mode is entered as soon as the V_{CC} or V_{IO} undervoltage condition is detected. The internal logic is reset and the transceiver is disabled. CAN bus pins are kept floating. As soon as both V_{CC} and V_{IO} voltages rise above corresponding undervoltage recovery thresholds, the device proceeds to Normal or Silent mode, depending on S pin state.

Normal Mode

In the normal mode, the transceiver is able to communicate via the bus lines. The signals are transmitted and received to the CAN controller via the pins TxD and RxD. The slopes on the bus lines outputs are optimized to give low EME.

Silent Mode

In the silent mode, the transmitter is disabled. The bus pins are in recessive state independent of TxD input. Transceiver listens to the bus and provides data to controller, but controller is prevented from sending any data to the bus.

Overtemperature Detection

A thermal protection circuit protects the IC from damage by switching off the transmitter if the junction temperature exceeds $T_{J(sd)}$ value. Because the transmitter dissipates most of the power, the power dissipation and temperature of the IC is reduced. All other IC functions continue to operate. The transmitter off-state resets when the temperature decreases below the shutdown threshold and pin TxD goes high. The thermal protection circuit is particularly needed when a bus line short circuits.

TxD Dominant Timeout Function

A TxD dominant timeout timer circuit prevents the bus lines being driven to a permanent dominant state (blocking all network communication) if pin TxD is forced permanently low by a hardware and/or software application failure. The timer is triggered by a negative edge on pin TxD. If the duration of the low-level on pin TxD exceeds the internal timer value $t_{dom(TxD)}$, the transmitter is disabled, driving the bus into a recessive state. The timer is reset by a positive edge on pin TxD.

This TxD dominant timeout time $t_{dom(TxD)}$ defines the minimum possible bit rate to 17 kbps.

Fail Safe Features

A current-limiting circuit protects the transmitter output stage from damage caused by accidental short circuit to either positive or negative supply voltage, although power dissipation increases during this fault condition.

Detection of undervoltage on supply pin (V_{CC} or V_{IO}) causes switching off device. After supply voltage is recovered TxD pin must be first released to high to allow sending dominant bits again.

The pins CANH and CANL are protected from automotive electrical transients (according to ISO 7637; see

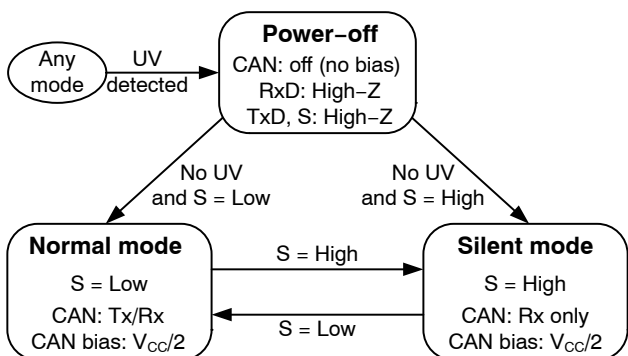

Notes:
 NCV7357-0
 UV detected: $V_{CC} < V_{UVdVCC}$
 No UV: $V_{CC} > V_{UVdVCC}$
 NCV7357-3
 UV detected: $V_{CC} < V_{UVdVCC}$ and/or $V_{IO} < V_{UVdVIO}$
 No UV: $V_{CC} > V_{UVdVCC}$ and $V_{IO} > V_{UVdVIO}$

NCV7357

Figure 7). Pins TxD and S are biased internally should the input become disconnected. Pins TxD, S and RxD will be floating, preventing reverse supply should the VCC supply be removed.

V_{IO} Supply Pin

The V_{IO} pin (available only on NCV7357-3 version) should be connected to microcontroller supply pin. By using V_{IO} supply pin shared with microcontroller the I/O levels between microcontroller and transceiver are properly adjusted. See Figure 4.

ABSOLUTE MAXIMUM RATINGS

Table 3. ABSOLUTE MAXIMUM RATINGS

Symbol	Parameter	Conditions	Min	Max	Unit
V _{SUP}	Supply voltage V _{CC} , V _{IO}		-0.3	+6.0	V
V _{CANH}	DC voltage at pin CANH	0 < V _{CC} < 5.5 V; no time limit	-42	+42	V
V _{CANL}	DC voltage at pin CANL	0 < V _{CC} < 5.5 V; no time limit	-42	+42	V
V _{CANH - CANL}	DC voltage between CANH and CANL		-42	+42	V
V _{IN}	DC voltage at pin TxD, S		-0.3	+6.0	V
V _{OUT}	DC voltage at pin RxD		-0.3	V _{SUP} + 0.3	V
V _{esdHBM}	Electrostatic discharge voltage at all pins, Component HBM	(Note 3)	-6	+6	kV
V _{esdCDM}	Electrostatic discharge voltage at all pins, Component CDM	(Note 4)	-750	+750	V
V _{esdIEC}	Electrostatic discharge voltage at pins CANH and CANL, System HBM (Note 6)	(Note 5)	-8	+8	kV
V _{schaft}	Voltage transients, pins CANH, CANL. Test Pulses According to ISO7637-2, Class C (Note 6)	test pulses 1	-100		V
		test pulses 2a		+75	V
		test pulses 3a	-150		V
		test pulses 3b		+100	V
Latch-up	Static latch-up at all pins	(Note 7)		150	mA
T _{stg}	Storage temperature		-55	+150	°C
T _J	Maximum junction temperature		-40	+170	°C
MSL _{SOIC}	Moisture sensitivity level for SOIC-8		2		-
MSL _{DFN}	Moisture sensitivity level for DFNW8		1		-

Stresses exceeding those listed in the Maximum Ratings table may damage the device. If any of these limits are exceeded, device functionality should not be assumed, damage may occur and reliability may be affected.

- Standardized human body model electrostatic discharge (ESD) pulses in accordance to EIA-JESD22. Equivalent to discharging a 100 pF capacitor through a 1.5 kΩ resistor
- Standardized charged device model ESD pulses when tested according to AEC-Q100-011
- System human body model electrostatic discharge (ESD) pulses in accordance to IEC 61000-4-2. Equivalent to discharging a 150 pF capacitor through a 330 Ω resistor referenced to GND
- Results were verified by external test house
- Static latch-up immunity: Static latch-up protection level when tested according to EIA/JESD78

Table 4. THERMAL CHARACTERISTICS

Parameter	Symbol	Value	Unit
Thermal characteristics SOIC-8 (Note 8)			
Thermal Resistance Junction-to-Air, Free air, 1S0P PCB (Note 9)	$R_{\theta JA}$	131	$^{\circ}\text{C}/\text{W}$
Thermal Resistance Junction-to-Air, Free air, 2S2P PCB (Note 10)	$R_{\theta JA}$	81	$^{\circ}\text{C}/\text{W}$
Thermal characteristics DFNW8 (Note 8)			
Thermal Resistance Junction-to-Air, Free air, 1S0P PCB (Note 9)	$R_{\theta JA}$	125	$^{\circ}\text{C}/\text{W}$
Thermal Resistance Junction-to-Air, Free air, 2S2P PCB (Note 10)	$R_{\theta JA}$	58	$^{\circ}\text{C}/\text{W}$

8. Refer to ELECTRICAL CHARACTERISTICS, RECOMMENDED OPERATING RANGES and/or APPLICATION INFORMATION for Safe Operating parameters

9. Values based on test board according to EIA/JEDEC Standard JESD51-3, signal layer with 10% trace coverage

10. Values based on test board according to EIA/JEDEC Standard JESD51-7, signal layers with 10% trace coverage

Table 5. ELECTRICAL CHARACTERISTICS ($V_{CC} = 4.75\text{ V}$ to 5.25 V ; $V_{IO} = 2.8\text{ V}$ to 5.5 V ; for typical values $T_A = 25^{\circ}\text{C}$, for min/max values $T_J = -40$ to $+150^{\circ}\text{C}$; $R_{LT} = 60\ \Omega$, $C_{RXD} = 15\text{ pF}$; unless otherwise noted. All voltages are referenced to GND (pin 2). Positive currents flow into the respective pin)

Symbol	Parameter	Conditions	Min	Typ	Max	Unit
--------	-----------	------------	-----	-----	-----	------

SUPPLY (Pin V_{CC})

V_{CC}	Power supply voltage	(Note 11)	4.75	5.0	5.25	V
I_{CC}	Supply current in Normal mode	Dominant; $V_{TXD} = \text{Low}$	30	45	55	mA
		Recessive; $V_{TXD} = \text{High}$	2.0	5.0	10	mA
		Normal mode, Dominant; $V_{TXD} = 0\text{ V}$; one of bus wires shorted $-3\text{ V} \leq (V_{CANH}, V_{CANL}) \leq +18\text{ V}$	2.0	-	105	mA
I_{CCS}	Supply current in silent mode NCV7357-3 version		0.1	-	1.3	mA
	Supply current in silent mode NCV7357-0 version		0.1	-	1.5	mA
V_{UVDVCC}	Undervoltage detection on V_{CC} pin		3.5	4.0	4.3	V

V_{IO} SUPPLY VOLTAGE (Pin V_{IO}) Only for NCV7357-3 version

V_{IO}	Supply voltage on pin V_{IO}		2.8	-	5.5	V
I_{IOS}	Supply current on pin V_{IO} in silent mode	$V_{TXD} = V_{IO}$	-	120	200	μA
I_{IONM}	Supply current on pin V_{IO} during normal mode	Dominant; $V_{TXD} = \text{Low}$	-	700	900	μA
		Recessive; $V_{TXD} = \text{High}$	-	460	600	
V_{UVDVIO}	Undervoltage detection voltage on V_{IO} pin		2.0	2.3	2.6	V

TRANSMITTER DATA INPUT (Pin TxD)

V_{IH}	High-level input voltage	Output recessive	2.0	-	-	V
V_{IL}	Low-level input voltage	Output dominant	-0.3	-	0.8	V
I_{IH}	High-level input current	$V_{TXD} = V_{CC} / V_{IO}$	-5.0	0	5.0	μA
I_{IL}	Low-level input current	$V_{TXD} = 0\text{ V}$	-300	-150	-75	μA
C_i	Input capacitance	(Note 12)	-	5	10	pF

TRANSMITTER DATA INPUT (Pin S)

V_{IH}	High-level input voltage	Silent mode	2.0	-	-	V
V_{IL}	Low-level input voltage	Normal mode	-0.3	-	0.8	V
I_{IH}	High-level input current	$V_S = V_{CC} / V_{IO}$	-1.0	0	1.0	μA
I_{IL}	Low-level input current	$V_S = 0\text{ V}$	-15	-	-1.0	μA
C_i	Input capacitance	(Note 12)	-	5	10	pF

Table 5. ELECTRICAL CHARACTERISTICS ($V_{CC} = 4.75\text{ V to }5.25\text{ V}$; $V_{IO} = 2.8\text{ V to }5.5\text{ V}$; for typical values $T_A = 25^\circ\text{C}$, for min/max values $T_J = -40\text{ to }+150^\circ\text{C}$; $R_{LT} = 60\ \Omega$, $C_{RxD} = 15\text{ pF}$; unless otherwise noted. All voltages are referenced to GND (pin 2). Positive currents flow into the respective pin)

RECEIVER DATA OUTPUT (Pin RxD)

I_{OH}	High-level output current	Normal mode $V_{RxD} = V_{CC} / V_{IO} - 0.4\text{ V}$	-8.0	-3.0	-1.0	mA
I_{OL}	Low-level output current	$V_{RxD} = 0.4\text{ V}$	1.0	6.0	12	mA

CAN TRANSMITTER (PINS CANH AND CANL)

$V_{o(dom)}(CANH)$	Dominant output voltage at pin CANH	Normal mode; $V_{TxD} = \text{Low}$; $t < t_{dom}(TxD)$; $50\ \Omega < R_{LT} < 65\ \Omega$	2.75	3.5	4.5	V
$V_{o(dom)}(CANL)$	Dominant output voltage at pin CANL	Normal mode; $V_{TxD} = \text{Low}$; $t < t_{dom}(TxD)$; $50\ \Omega < R_{LT} < 65\ \Omega$	0.5	1.5	2.25	V
$V_{o(rec)}$	Recessive output voltage at pins CANH and CANL	Normal or Silent mode; $V_{TxD} = \text{High}$ or $V_{TxD} = \text{Low}$ and $t > t_{dom}(TxD)$; no load	2.0	2.5	3.0	V
$V_{o(dom)}(diff)$	Differential dominant output voltage ($V_{CANH} - V_{CANL}$)	Normal mode; $V_{TxD} = \text{Low}$; $t < t_{dom}(TxD)$; $45\ \Omega < R_{LT} < 65\ \Omega$	1.5	2.25	3.0	V
$V_{o(dom)}(diff)_{ARB}$		Normal mode; $V_{TxD} = \text{Low}$; $t < t_{dom}(TxD)$; $R_{LT} = 2\ 240\ \Omega$ (Note 12)	1.5	-	5.0	V
$V_{o(rec)}(diff)$	Differential recessive output voltage ($V_{CANH} - V_{CANL}$)	Normal or Silent mode; $V_{TxD} = \text{High}$ or $V_{TxD} = \text{Low}$ and $t > t_{dom}(TxD)$; no load	-50	0	+50	mV
$V_{o(dom)}(sym)$	Dominant output voltage driver symmetry $V_{o(dom)}(sym) = V_{o(CANH)}(dom) + V_{o(CANL)}(dom)$	TxD = square wave up to 1 MHz; $C_{ST} = 4.7\text{ nF}$	0.9	1.0	1.1	V_{CC}
$I_{o(sc)}(CANH)$	Short circuit output current at pin CANH in dominant	Normal mode; TxD = Low, $t < t_{dom}(TxD)$; $-3\text{ V} \leq V_{CANH} \leq +18\text{ V}$	-100	-70	+1.0	mA
$I_{o(sc)}(CANL)$	Short circuit output current at pin CANL in dominant	Normal mode; TxD = Low, $t < t_{dom}(TxD)$; $-3\text{ V} \leq V_{CANL} \leq +36\text{ V}$	-1.0	+70	+100	mA
$I_{o(sc)}(rec)$	Short circuit output current at pins CANH and CANL in recessive	Normal or Silent mode; TxD = High, $-27\text{ V} < V_{CANH}$, $V_{CANL} < +32\text{ V}$	-5.0	-	+5.0	mA

CAN RECEIVER (Pins CANH and CANL)

$I_{LEAK(off)}$	Input leakage current	$0\ \Omega < R(V_{CC}\text{ to GND}) < 1\ \text{M}\Omega$ $V_{CANH} = V_{CANL} = 5\text{ V}$	-5.0	0	+5.0	μA
		$V_{CC} = V_{IO} = 0\text{ V}$ $V_{CANH} = V_{CANL} = 5\text{ V}$	-5.0	0	+5.0	μA
$V_{i(rec)}(diff)_{NM}$	Differential input voltage range recessive state	Normal or Silent mode; $-12\text{ V} \leq V_{CANH}$, $V_{CANL} \leq +12\text{ V}$; no load	-3.0	-	0.5	V
$V_{i(dom)}(diff)_{NM}$	Differential input voltage range dominant state	Normal or Silent mode; $-12\text{ V} \leq V_{CANH}$, $V_{CANL} \leq +12\text{ V}$; no load	0.9	-	8.0	V
$V_{i(th)}(diff)_{NM}$	Differential receiver threshold voltage	Normal or Silent mode; $-12\text{ V} \leq V_{CANH}$, $V_{CANL} \leq +12\text{ V}$; no load	0.5	-	0.9	V
$V_{i(th)}(diff)_{NM_E}$		Normal or Silent mode; extended, $-30\text{ V} \leq V_{CANH}$, $V_{CANL} \leq +35\text{ V}$; no load	0.4	-	1.0	V
$R_{i(cm)}$	Common-mode input resistance at pins CANH and CANL	$-2\text{ V} \leq V_{CANH}$, $V_{CANL} \leq +7\text{ V}$	15	25	37	k Ω

NCV7357

Table 5. ELECTRICAL CHARACTERISTICS ($V_{CC} = 4.75\text{ V to }5.25\text{ V}$; $V_{IO} = 2.8\text{ V to }5.5\text{ V}$; for typical values $T_A = 25^\circ\text{C}$, for min/max values $T_J = -40\text{ to }+150^\circ\text{C}$; $R_{LT} = 60\ \Omega$, $C_{RxD} = 15\text{ pF}$; unless otherwise noted. All voltages are referenced to GND (pin 2). Positive currents flow into the respective pin)

$R_{i(cm)(m)}$	Matching between pin CANH and pin CANL common mode input resistance	$V_{CANH} = V_{CANL} = +5\text{ V}$	-1	0	+1	%
$R_{i(diff)}$	Differential input resistance	$R_{i(diff)} = R_{i(cm)(CANH)} + R_{i(cm)(CANL)}$ $-2\text{ V} \leq V_{CANH}, V_{CANL} \leq +7\text{ V}$	25	50	75	k Ω
C_i	Input capacitance at pins CANH and CANL	$V_{TxD} = \text{High}$; (Note 12)	-	7.5	20	pF
$C_{i(diff)}$	Differential input capacitance	$V_{TxD} = \text{High}$; (Note 12)	-	3.75	10	pF

TIMING CHARACTERISTICS (see Figure 5, Figure 6 and Figure 8)

$t_{d(TxD-BUSon)}$	Propagation delay TxD to bus active	Normal mode (Note 13)	-	75	-	ns
$t_{d(TxD-BUSoff)}$	Propagation delay TxD to bus inactive	Normal mode (Note 13)	-	85	-	ns
$t_{d(BUSon-RxD)}$	Propagation delay bus active to RxD	Normal or Silent mode (Note 13)	-	24	-	ns
$t_{d(BUSoff-RxD)}$	Propagation delay bus inactive to RxD	Normal or Silent mode (Note 13)	-	32	-	ns
t_{pd_dr}	Propagation delay TxD to RxD dominant to recessive transition	Normal mode (Note 13)	50	100	210	ns
t_{pd_rd}	Propagation delay TxD to RxD recessive to dominant transition	Normal mode (Note 13)	50	120	210	ns
$t_{d(s-nm)}$	Operating mode change delay	Silent mode to Normal mode	5.0	11	50	μs
$t_{dom(TxD)}$	TxD dominant timeout	Normal mode; $V_{TxD} = \text{Low}$	1.0	-	10	ms
$t_{bit(RxD)}$	Bit time on RxD pin	$t_{bit(TxD)} = 500\text{ ns}$ (Note 13)	400	-	550	ns
		$t_{bit(TxD)} = 200\text{ ns}$ (Note 13)	120	-	220	ns
$t_{bit(Vi(diff))}$	Bit time on bus (CANH - CANL pin)	$t_{bit(TxD)} = 500\text{ ns}$ (Note 13)	435	-	530	ns
		$t_{bit(TxD)} = 200\text{ ns}$ (Note 13)	155	-	210	ns
Δt_{rec}	Receiver timing symmetry $\Delta t_{rec} = t_{bit(RxD)} - t_{bit(Vi(diff))}$	$t_{bit(TxD)} = 500\text{ ns}$ (Note 13)	-65	-	40	ns
		$t_{bit(TxD)} = 200\text{ ns}$ (Note 13)	-45	-	15	ns

THERMAL SHUTDOWN

$T_{J(sd)}$	Shutdown junction temperature	Junction temperature rising	160	180	200	$^\circ\text{C}$
-------------	-------------------------------	-----------------------------	-----	-----	-----	------------------

Product parametric performance is indicated in the Electrical Characteristics for the listed test conditions, unless otherwise noted. Product performance may not be indicated by the Electrical Characteristics if operated under different conditions.

11. In the range between $V_{UVDDVCC}$ and 4.75 V and from 5.25 V to 6 V the chip is fully functional; some parameters may be outside of the specification

12. Values based on design and characterization, not tested in production

13. $C_{LT} = 100\text{ pF}$, C_{ST} not present, $C_{RxD} = 15\text{ pF}$

MEASUREMENTS SETUPS AND DEFINITIONS

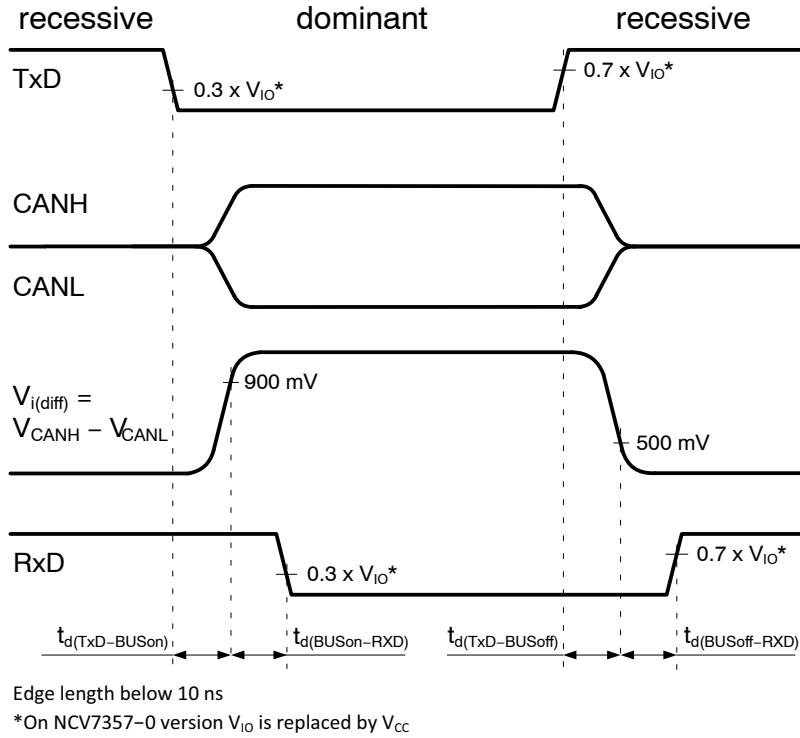

Figure 5. Transceiver Timing Diagram - Propagation Delays

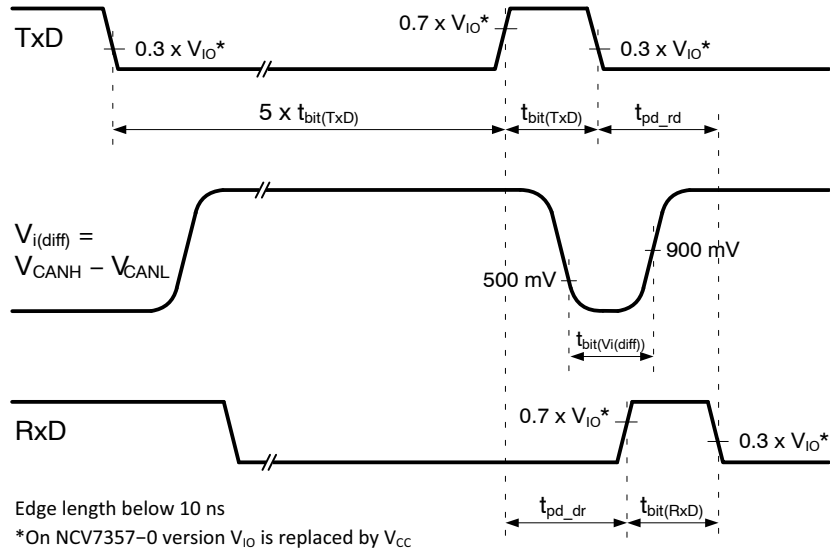

Figure 6. Transceiver Timing Diagram - Loop Delay and Recessive Bit Time

NCV7357

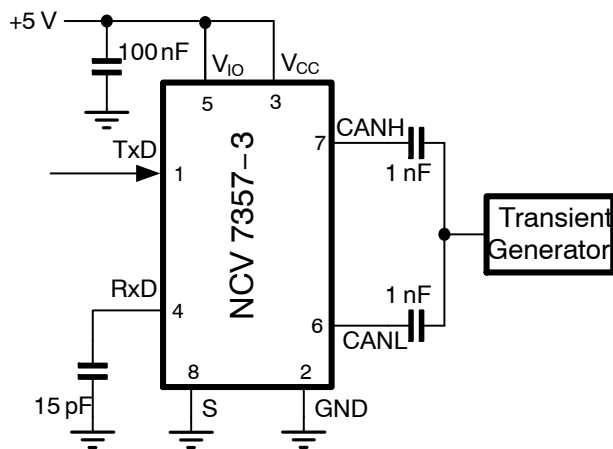

Figure 7. Test Circuit for Automotive Transients

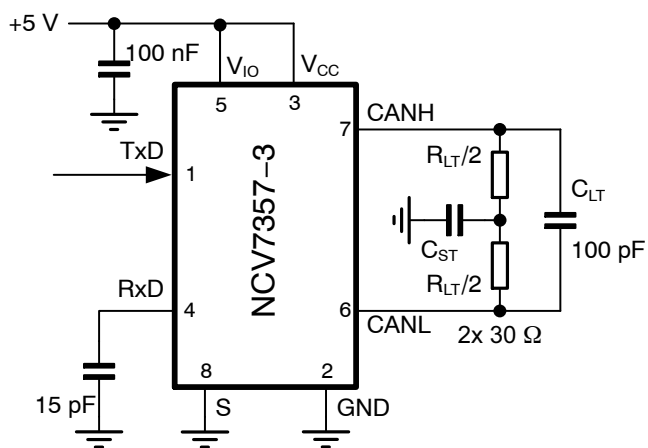

Figure 8. Test Circuit for Timing Characteristics

Table 6. ISO 11898–2:2016 Parameter Cross–Reference Table

ISO 11898–2:2016 Specification		NCV7357 Datasheet	
Parameter	Notation	Symbol	
DOMINANT OUTPUT CHARACTERISTICS			
Single ended voltage on CAN_H	V_{CAN_H}	$V_{o(dom)}(CANH)$	
Single ended voltage on CAN_L	V_{CAN_L}	$V_{o(dom)}(CANL)$	
Differential voltage on normal bus load	V_{Diff}	$V_{o(dom)}(diff)$	
Differential voltage on effective resistance during arbitration	V_{Diff}	$V_{o(dom)}(diff_ARB)$	
Differential voltage on extended bus load range (optional)	V_{Diff}	$V_{o(dom)}(diff)$	
DRIVER SYMMETRY			
Driver symmetry	V_{SYM}	$V_{o(dom)}(sym)$	
DRIVER OUTPUT CURRENT			
Absolute current on CAN_H	I_{CAN_H}	$I_{o(SC)}(CANH)$	
Absolute current on CAN_L	I_{CAN_L}	$I_{o(SC)}(CANL)$	
RECEIVER OUTPUT CHARACTERISTICS, BUS BIASING ACTIVE			
Single ended output voltage on CAN_H	V_{CAN_H}	$V_{o(rec)}$	
Single ended output voltage on CAN_L	V_{CAN_L}	$V_{o(rec)}$	
Differential output voltage	V_{Diff}	$V_{o(rec)}(diff)$	
RECEIVER OUTPUT CHARACTERISTICS, BUS BIASING INACTIVE			
Single ended output voltage on CAN_H	V_{CAN_H}	NA	
Single ended output voltage on CAN_L	V_{CAN_L}	NA	
Differential output voltage	V_{Diff}	NA	
OPTIONAL TRANSMIT DOMINANT TIMEOUT			
Transmit dominant timeout, long	t_{dom}	$t_{dom}(TxD)$	
Transmit dominant timeout, short	t_{dom}	NA	
STATIC RECEIVER INPUT CHARACTERISTICS, BUS BIASING ACTIVE/ INACTIVE			
Recessive state differential input voltage range	V_{Diff}	$V_{i(rec)}(diff)_NM$	
Dominant state differential input voltage range	V_{Diff}	$V_{i(dom)}(diff)_NM$	
RECEIVER INPUT RESISTANCE			
Differential internal resistance	R_{Diff}	$R_{i(diff)}$	
Single ended internal resistance	R_{CAN_H} R_{CAN_L}	$R_{i(cm)}$ $R_{i(cm)}$	
RECEIVER INPUT RESISTANCE MATCHING			
Matching a of internal resistance	m_R	$R_{i(cm)}(m)$	
IMPLEMENTATION LOOP DELAY REQUIREMENT			
Loop delay	t_{Loop}	t_{pd_rd} t_{pd_dr}	
OPTIONAL IMPLEMENTATION DATA SIGNAL TIMING REQUIREMENTS FOR USE WITH BIT RATES ABOVE 1 MBIT/S AND UP TO 2 MBIT/S			
Transmitted recessive bit width @ 2 Mbit/s	$t_{Bit}(Bus)$	$t_{bit}(Vi(diff))$	
Received recessive bit width @ 2 Mbit/s	$t_{Bit}(RXD)$	$t_{bit}(RxD)$	
Receiver timing symmetry @ 2 Mbit/s	Δt_{Rec}	Δt_{rec}	
OPTIONAL IMPLEMENTATION DATA SIGNAL TIMING REQUIREMENTS FOR USE WITH BIT RATES ABOVE 2 MBIT/S AND UP TO 5 MBIT/S			
Transmitted recessive bit width @ 5 Mbit/s	$t_{Bit}(Bus)$	$t_{bit}(Vi(diff))$	
Transmitted recessive bit width @ 5 Mbit / s	$t_{Bit}(RXD)$	$t_{bit}(RxD)$	

NCV7357

Received recessive bit width @ 5 Mbit / s	Δt_{Rec}	Δt_{rec}
---	------------------	------------------

MAXIMUM RATINGS OF V_{CAN_H} , V_{CAN_L} AND V_{DIFF}

Maximum rating V_{Diff}	V_{Diff}	$V_{CANH} - CANL$
General maximum rating V_{CAN_H} and V_{CAN_L}	V_{CAN_H} V_{CAN_L}	V_{CANH} V_{CANL}
Optional: Extended maximum rating V_{CAN_H} and V_{CAN_L}	V_{CAN_H} V_{CAN_L}	NA

MAXIMUM LEAKAGE CURRENTS ON CAN_H AND CAN_L, UNPOWERED

Leakage current on CAN_H, CAN_L	I_{CAN_H} , I_{CAN_L}	$I_{LEAK(off)}$
---------------------------------	--------------------------------	-----------------

BUS BIASING CONTROL TIMINGS

CAN activity filter time, long	t_{Filter}	NA
CAN activity filter time, short	t_{Filter}	NA
Wake-up timeout, short	t_{Wake}	NA
Wake-up timeout, long	t_{Wake}	NA
Timeout for bus inactivity (Required for selective wake-up implementation only)	$t_{Silence}$	NA
Bus Bias reaction time (Required for selective wake-up implementation only)	t_{Bias}	NA

Table 7. ORDERING INFORMATION

Part Number	Description	Temperature Range	Package	Shipping
NCV7357D10R2G	High Speed CAN FD Transceiver	-40°C to +150°C	SOIC 150 8 GREEN (Matte Sn, JEDEC MS-012) (Pb-Free)	3000 / Tape & Reel
NCV7357D13R2G	High Speed CAN FD Transceiver with V_{IO} pin			3000 / Tape & Reel
NCV7357MW0R2G	High Speed CAN FD Transceiver	-40°C to +150°C	DFNW8 Wettable Flank (Pb-Free)	3000 / Tape & Reel
NCV7357MW3R2G	High Speed CAN FD Transceiver with V_{IO} pin			3000 / Tape & Reel

MECHANICAL CASE OUTLINE PACKAGE DIMENSIONS

ON Semiconductor®



SCALE 2:1

DFNW8 3x3, 0.65P CASE 507AB ISSUE E

DATE 02 JUL 2021

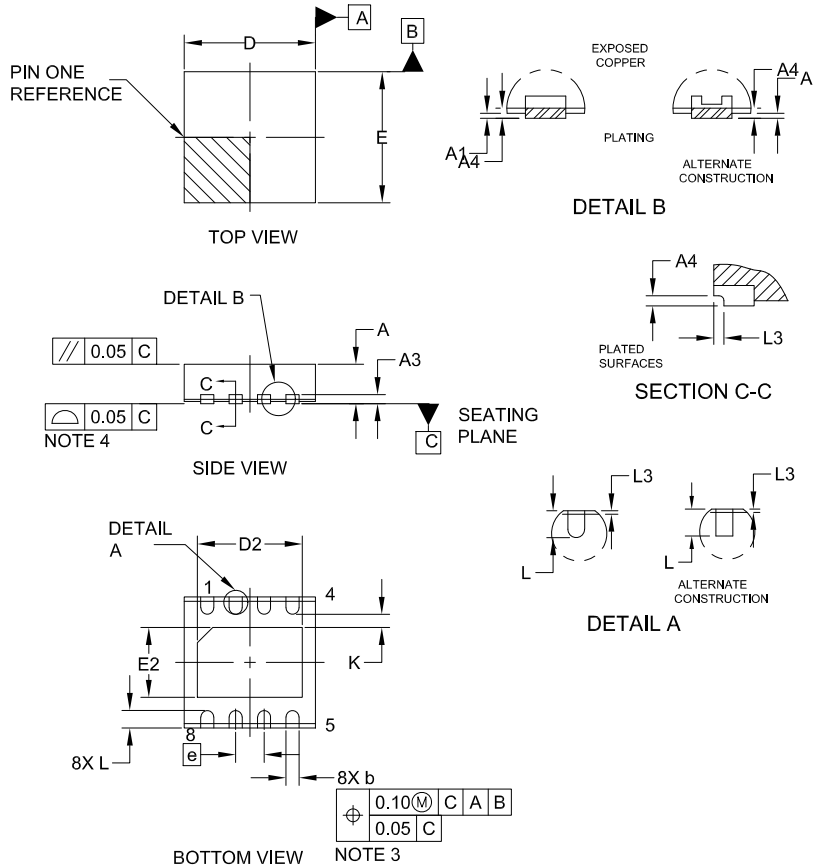

NOTES:

1. DIMENSIONING AND TOLERANCING PER ASME Y14.5M, 1994.
2. CONTROLLING DIMENSION: MILLIMETERS
3. DIMENSION b APPLIES TO PLATED TERMINALS AND IS MEASURED BETWEEN 0.15 AND 0.30MM FROM THE TERMINAL TIP.
4. COPLANARITY APPLIES TO THE EXPOSED PAD AS WELL AS THE TERMINALS.
5. THIS DEVICE CONTAINS WETTABLE FLANK DESIGN FEATURES TO AID IN FILLET FORMATION ON THE LEADS DURING MOUNTING.

DIM	MILLIMETERS		
	MIN.	NOM.	MAX.
A	0.80	0.85	0.90
A1	—	—	0.05
A3	0.20 REF		
A4	0.10	—	—
b	0.25	0.30	0.35
D	2.95	3.00	3.05
D2	2.30	2.40	2.50
E	2.95	3.00	3.05
E2	1.50	1.60	1.70
e	0.65 BSC		
K	0.30 REF		
L	0.35	0.40	0.45
L3	0.00	0.05	0.10

GENERIC MARKING DIAGRAM*

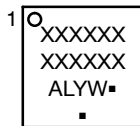

- XXXXXX = Specific Device Code
- A = Assembly Location
- L = Wafer Lot
- Y = Year
- W = Work Week
- = Pb-Free Package

(Note: Microdot may be in either location)

*This information is generic. Please refer to device data sheet for actual part marking. Pb-Free indicator, "G" or microdot "▪", may or may not be present. Some products may not follow the Generic Marking.

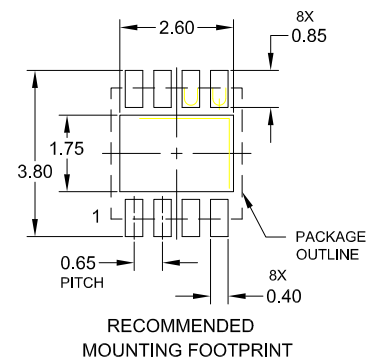

DOCUMENT NUMBER:	98AON14978G	Electronic versions are uncontrolled except when accessed directly from the Document Repository. Printed versions are uncontrolled except when stamped "CONTROLLED COPY" in red.
DESCRIPTION:	DFNW8 3x3, 0.65P	PAGE 1 OF 1

ON Semiconductor and ON are trademarks of Semiconductor Components Industries, LLC dba ON Semiconductor or its subsidiaries in the United States and/or other countries. ON Semiconductor reserves the right to make changes without further notice to any products herein. ON Semiconductor makes no warranty, representation or guarantee regarding the suitability of its products for any particular purpose, nor does ON Semiconductor assume any liability arising out of the application or use of any product or circuit, and specifically disclaims any and all liability, including without limitation special, consequential or incidental damages. ON Semiconductor does not convey any license under its patent rights nor the rights of others.

MECHANICAL CASE OUTLINE PACKAGE DIMENSIONS



SCALE 1:1

SOIC-8 NB
CASE 751-07
ISSUE AK

DATE 16 FEB 2011

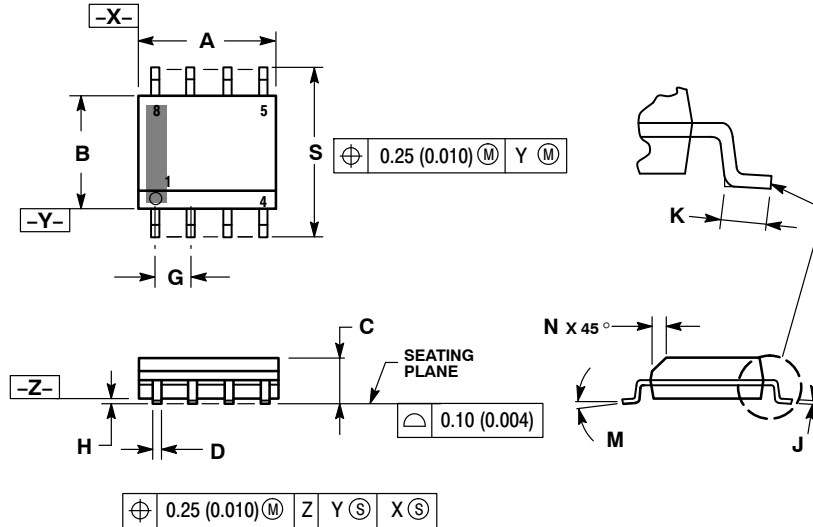

- NOTES:
1. DIMENSIONING AND TOLERANCING PER ANSI Y14.5M, 1982.
 2. CONTROLLING DIMENSION: MILLIMETER.
 3. DIMENSION A AND B DO NOT INCLUDE MOLD PROTRUSION.
 4. MAXIMUM MOLD PROTRUSION 0.15 (0.006) PER SIDE.
 5. DIMENSION D DOES NOT INCLUDE DAMBAR PROTRUSION. ALLOWABLE DAMBAR PROTRUSION SHALL BE 0.127 (0.005) TOTAL IN EXCESS OF THE D DIMENSION AT MAXIMUM MATERIAL CONDITION.
 6. 751-01 THRU 751-06 ARE OBSOLETE. NEW STANDARD IS 751-07.

DIM	MILLIMETERS		INCHES	
	MIN	MAX	MIN	MAX
A	4.80	5.00	0.189	0.197
B	3.80	4.00	0.150	0.157
C	1.35	1.75	0.053	0.069
D	0.33	0.51	0.013	0.020
G	1.27 BSC		0.050 BSC	
H	0.10	0.25	0.004	0.010
J	0.19	0.25	0.007	0.010
K	0.40	1.27	0.016	0.050
M	0°	8°	0°	8°
N	0.25	0.50	0.010	0.020
S	5.80	6.20	0.228	0.244

GENERIC MARKING DIAGRAM*

SOLDERING FOOTPRINT*

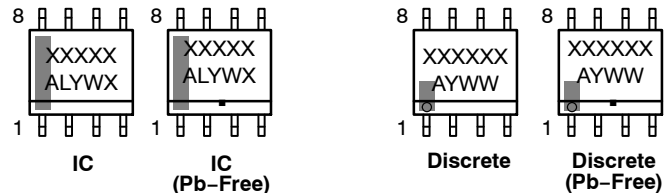
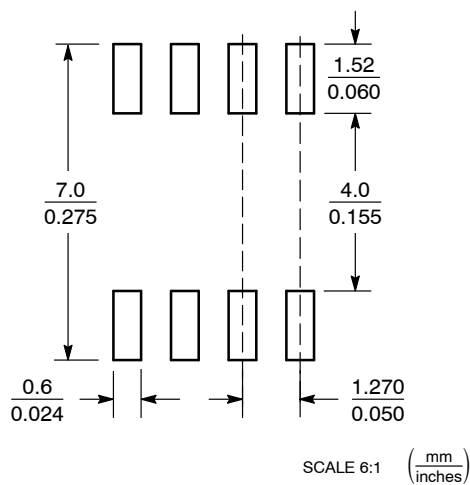

XXXXX = Specific Device Code
A = Assembly Location
L = Wafer Lot
Y = Year
W = Work Week
▪ = Pb-Free Package

XXXXXX = Specific Device Code
A = Assembly Location
Y = Year
WW = Work Week
▪ = Pb-Free Package

*This information is generic. Please refer to device data sheet for actual part marking. Pb-Free indicator, "G" or microdot "▪", may or may not be present. Some products may not follow the Generic Marking.

*For additional information on our Pb-Free strategy and soldering details, please download the ON Semiconductor Soldering and Mounting Techniques Reference Manual, SOLDERRM/D.

STYLES ON PAGE 2

DOCUMENT NUMBER:	98ASB42564B	Electronic versions are uncontrolled except when accessed directly from the Document Repository. Printed versions are uncontrolled except when stamped "CONTROLLED COPY" in red.
DESCRIPTION:	SOIC-8 NB	PAGE 1 OF 2

onsemi and ONsemi are trademarks of Semiconductor Components Industries, LLC dba onsemi or its subsidiaries in the United States and/or other countries. onsemi reserves the right to make changes without further notice to any products herein. onsemi makes no warranty, representation or guarantee regarding the suitability of its products for any particular purpose, nor does onsemi assume any liability arising out of the application or use of any product or circuit, and specifically disclaims any and all liability, including without limitation special, consequential or incidental damages. onsemi does not convey any license under its patent rights nor the rights of others.

SOIC-8 NB
CASE 751-07
ISSUE AK

DATE 16 FEB 2011

- | | | | |
|---|--|--|--|
| <p>STYLE 1:
 PIN 1. EMITTER
 2. COLLECTOR
 3. COLLECTOR
 4. EMITTER
 5. EMITTER
 6. BASE
 7. BASE
 8. EMITTER</p> | <p>STYLE 2:
 PIN 1. COLLECTOR, DIE, #1
 2. COLLECTOR, #1
 3. COLLECTOR, #2
 4. COLLECTOR, #2
 5. BASE, #2
 6. EMITTER, #2
 7. BASE, #1
 8. EMITTER, #1</p> | <p>STYLE 3:
 PIN 1. DRAIN, DIE #1
 2. DRAIN, #1
 3. DRAIN, #2
 4. DRAIN, #2
 5. GATE, #2
 6. SOURCE, #2
 7. GATE, #1
 8. SOURCE, #1</p> | <p>STYLE 4:
 PIN 1. ANODE
 2. ANODE
 3. ANODE
 4. ANODE
 5. ANODE
 6. ANODE
 7. ANODE
 8. COMMON CATHODE</p> |
| <p>STYLE 5:
 PIN 1. DRAIN
 2. DRAIN
 3. DRAIN
 4. DRAIN
 5. GATE
 6. GATE
 7. SOURCE
 8. SOURCE</p> | <p>STYLE 6:
 PIN 1. SOURCE
 2. DRAIN
 3. DRAIN
 4. SOURCE
 5. SOURCE
 6. GATE
 7. GATE
 8. SOURCE</p> | <p>STYLE 7:
 PIN 1. INPUT
 2. EXTERNAL BYPASS
 3. THIRD STAGE SOURCE
 4. GROUND
 5. DRAIN
 6. GATE 3
 7. SECOND STAGE Vd
 8. FIRST STAGE Vd</p> | <p>STYLE 8:
 PIN 1. COLLECTOR, DIE #1
 2. BASE, #1
 3. BASE, #2
 4. COLLECTOR, #2
 5. COLLECTOR, #2
 6. EMITTER, #2
 7. EMITTER, #1
 8. COLLECTOR, #1</p> |
| <p>STYLE 9:
 PIN 1. EMITTER, COMMON
 2. COLLECTOR, DIE #1
 3. COLLECTOR, DIE #2
 4. EMITTER, COMMON
 5. EMITTER, COMMON
 6. BASE, DIE #2
 7. BASE, DIE #1
 8. EMITTER, COMMON</p> | <p>STYLE 10:
 PIN 1. GROUND
 2. BIAS 1
 3. OUTPUT
 4. GROUND
 5. GROUND
 6. BIAS 2
 7. INPUT
 8. GROUND</p> | <p>STYLE 11:
 PIN 1. SOURCE 1
 2. GATE 1
 3. SOURCE 2
 4. GATE 2
 5. DRAIN 2
 6. DRAIN 2
 7. DRAIN 1
 8. DRAIN 1</p> | <p>STYLE 12:
 PIN 1. SOURCE
 2. SOURCE
 3. SOURCE
 4. GATE
 5. DRAIN
 6. DRAIN
 7. DRAIN
 8. DRAIN</p> |
| <p>STYLE 13:
 PIN 1. N.C.
 2. SOURCE
 3. SOURCE
 4. GATE
 5. DRAIN
 6. DRAIN
 7. DRAIN
 8. DRAIN</p> | <p>STYLE 14:
 PIN 1. N-SOURCE
 2. N-GATE
 3. P-SOURCE
 4. P-GATE
 5. P-DRAIN
 6. P-DRAIN
 7. N-DRAIN
 8. N-DRAIN</p> | <p>STYLE 15:
 PIN 1. ANODE 1
 2. ANODE 1
 3. ANODE 1
 4. ANODE 1
 5. CATHODE, COMMON
 6. CATHODE, COMMON
 7. CATHODE, COMMON
 8. CATHODE, COMMON</p> | <p>STYLE 16:
 PIN 1. EMITTER, DIE #1
 2. BASE, DIE #1
 3. EMITTER, DIE #2
 4. BASE, DIE #2
 5. COLLECTOR, DIE #2
 6. COLLECTOR, DIE #2
 7. COLLECTOR, DIE #1
 8. COLLECTOR, DIE #1</p> |
| <p>STYLE 17:
 PIN 1. VCC
 2. V2OUT
 3. V1OUT
 4. TXE
 5. RXE
 6. VEE
 7. GND
 8. ACC</p> | <p>STYLE 18:
 PIN 1. ANODE
 2. ANODE
 3. SOURCE
 4. GATE
 5. DRAIN
 6. DRAIN
 7. CATHODE
 8. CATHODE</p> | <p>STYLE 19:
 PIN 1. SOURCE 1
 2. GATE 1
 3. SOURCE 2
 4. GATE 2
 5. DRAIN 2
 6. MIRROR 2
 7. DRAIN 1
 8. MIRROR 1</p> | <p>STYLE 20:
 PIN 1. SOURCE (N)
 2. GATE (N)
 3. SOURCE (P)
 4. GATE (P)
 5. DRAIN
 6. DRAIN
 7. DRAIN
 8. DRAIN</p> |
| <p>STYLE 21:
 PIN 1. CATHODE 1
 2. CATHODE 2
 3. CATHODE 3
 4. CATHODE 4
 5. CATHODE 5
 6. COMMON ANODE
 7. COMMON ANODE
 8. CATHODE 6</p> | <p>STYLE 22:
 PIN 1. I/O LINE 1
 2. COMMON CATHODE/VCC
 3. COMMON CATHODE/VCC
 4. I/O LINE 3
 5. COMMON ANODE/GND
 6. I/O LINE 4
 7. I/O LINE 5
 8. COMMON ANODE/GND</p> | <p>STYLE 23:
 PIN 1. LINE 1 IN
 2. COMMON ANODE/GND
 3. COMMON ANODE/GND
 4. LINE 2 IN
 5. LINE 2 OUT
 6. COMMON ANODE/GND
 7. COMMON ANODE/GND
 8. LINE 1 OUT</p> | <p>STYLE 24:
 PIN 1. BASE
 2. EMITTER
 3. COLLECTOR/ANODE
 4. COLLECTOR/ANODE
 5. CATHODE
 6. CATHODE
 7. COLLECTOR/ANODE
 8. COLLECTOR/ANODE</p> |
| <p>STYLE 25:
 PIN 1. VIN
 2. N/C
 3. REXT
 4. GND
 5. IOUT
 6. IOUT
 7. IOUT
 8. IOUT</p> | <p>STYLE 26:
 PIN 1. GND
 2. dv/dt
 3. ENABLE
 4. ILIMIT
 5. SOURCE
 6. SOURCE
 7. SOURCE
 8. VCC</p> | <p>STYLE 27:
 PIN 1. ILIMIT
 2. OVLO
 3. UVLO
 4. INPUT+
 5. SOURCE
 6. SOURCE
 7. SOURCE
 8. DRAIN</p> | <p>STYLE 28:
 PIN 1. SW_TO_GND
 2. DASIC_OFF
 3. DASIC_SW_DET
 4. GND
 5. V_MON
 6. VBULK
 7. VBULK
 8. VIN</p> |
| <p>STYLE 29:
 PIN 1. BASE, DIE #1
 2. EMITTER, #1
 3. BASE, #2
 4. EMITTER, #2
 5. COLLECTOR, #2
 6. COLLECTOR, #2
 7. COLLECTOR, #1
 8. COLLECTOR, #1</p> | <p>STYLE 30:
 PIN 1. DRAIN 1
 2. DRAIN 1
 3. GATE 2
 4. SOURCE 2
 5. SOURCE 1/DRAIN 2
 6. SOURCE 1/DRAIN 2
 7. SOURCE 1/DRAIN 2
 8. GATE 1</p> | | |

DOCUMENT NUMBER:	98ASB42564B	Electronic versions are uncontrolled except when accessed directly from the Document Repository. Printed versions are uncontrolled except when stamped "CONTROLLED COPY" in red.
DESCRIPTION:	SOIC-8 NB	PAGE 2 OF 2

onsemi and **ONSEMI** are trademarks of Semiconductor Components Industries, LLC dba **onsemi** or its subsidiaries in the United States and/or other countries. **onsemi** reserves the right to make changes without further notice to any products herein. **onsemi** makes no warranty, representation or guarantee regarding the suitability of its products for any particular purpose, nor does **onsemi** assume any liability arising out of the application or use of any product or circuit, and specifically disclaims any and all liability, including without limitation special, consequential or incidental damages. **onsemi** does not convey any license under its patent rights nor the rights of others.

onsemi, **Onsemi**, and other names, marks, and brands are registered and/or common law trademarks of Semiconductor Components Industries, LLC dba "**onsemi**" or its affiliates and/or subsidiaries in the United States and/or other countries. **onsemi** owns the rights to a number of patents, trademarks, copyrights, trade secrets, and other intellectual property. A listing of **onsemi**'s product/patent coverage may be accessed at www.onsemi.com/site/pdf/Patent-Marking.pdf. **onsemi** reserves the right to make changes at any time to any products or information herein, without notice. The information herein is provided "as-is" and **onsemi** makes no warranty, representation or guarantee regarding the accuracy of the information, product features, availability, functionality, or suitability of its products for any particular purpose, nor does **onsemi** assume any liability arising out of the application or use of any product or circuit, and specifically disclaims any and all liability, including without limitation special, consequential or incidental damages. Buyer is responsible for its products and applications using **onsemi** products, including compliance with all laws, regulations and safety requirements or standards, regardless of any support or applications information provided by **onsemi**. "Typical" parameters which may be provided in **onsemi** data sheets and/or specifications can and do vary in different applications and actual performance may vary over time. All operating parameters, including "Typicals" must be validated for each customer application by customer's technical experts. **onsemi** does not convey any license under any of its intellectual property rights nor the rights of others. **onsemi** products are not designed, intended, or authorized for use as a critical component in life support systems or any FDA Class 3 medical devices or medical devices with a same or similar classification in a foreign jurisdiction or any devices intended for implantation in the human body. Should Buyer purchase or use **onsemi** products for any such unintended or unauthorized application, Buyer shall indemnify and hold **onsemi** and its officers, employees, subsidiaries, affiliates, and distributors harmless against all claims, costs, damages, and expenses, and reasonable attorney fees arising out of, directly or indirectly, any claim of personal injury or death associated with such unintended or unauthorized use, even if such claim alleges that **onsemi** was negligent regarding the design or manufacture of the part. **onsemi** is an Equal Opportunity/Affirmative Action Employer. This literature is subject to all applicable copyright laws and is not for resale in any manner.

ADDITIONAL INFORMATION

TECHNICAL PUBLICATIONS:

Technical Library: www.onsemi.com/design/resources/technical-documentation
onsemi Website: www.onsemi.com

ONLINE SUPPORT: www.onsemi.com/support

For additional information, please contact your local Sales Representative at www.onsemi.com/support/sales



Looking for pricing, stock, or lifecycle information?

Click below to explore more details on WIN SOURCE:

 [View NCV7357MW0R2G on WIN SOURCE](#)

 [ON Semiconductor](#) Information

Optimize Your Supply Chain with WIN SOURCE Solutions

-  Global Sourcing Solution
-  Obsolete Management
-  Cost Control Management
-  Shortage Management
-  Alternative Solution
-  Excess Inventory Management