

Structure : Silicon Monolithic Integrated Circuit
 Product Name : BTL Driver For CD-ROM

Device Name : **BA5983FM**

- Features :
- Driver exclusively for the 4-ch BTL
 - HSOP-M28 PIN power package
 - A wide dynamic range [PreVcc=8V, PowVcc=5V, 4V(Typ.) when RL=8Ω]
 - A built-in thermal shutdown circuit installed.
 - The power supplies such as PreVcc, PowVcc of CH1 and CH2, and PowVcc of CH3 and CH4 are supplied independently to achieve an efficient drive.
 - The standby mode can be controlled independently in CH1 to 3 and CH4.
 - Setting all of CH1-4 to the standby mode leads the entire circuit to the standby mode.
 - The driver pre-stage OP-amp features GND-sense and output rail-to-rail to make this IC suitable for a low voltage DSP.

○ ABSOLUTE MAXIMUM RATINGS (Ta=25°C)

Parameter	Symbol	Limits	Unit
Power Supply Voltage	PREVcc, POWVcc	13.5	V
Power Dissipation	Pd	2.2 *1	W
Output current	IOMAX	1 *2	A
Operating Temperature Range	Topr	-35 to 85	°C
Storage Temperature Range	Tstg	-55 to 150	°C

*1 When mounted on the glass/epoxy board with the size: 70 mm×70 mm, the thickness: 1.6 mm, and the rate of copper foil occupancy area: 3% or less.
 Over Ta=25°C, derating at the rate of 17.6mW/°C.

*2 The power dissipation should be specified within the ASO range.

○ OPERATING POWER SUPPLY VOLTAGE RANGE

(To determine a power supply voltage, the power dissipation must be taken into consideration.)

PREVcc	4.5 to 13.2(V)
POWVcc	4.5 to PREVcc (V)

This product has not been checked for the strategic materials (or service) defined in the Foreign Exchange and Foreign Trade Control Law of Japan so that a verification work is required before exporting it.

Not designed for radiation resistance.

○ ELECTRIC CHARACTERISTICS (Ta=25°C, Vcc=12V, PVcc1=PVcc2=5V, BIAS=2.5V, RL=8Ω, Rd=0.5Ω, C=100pF, unless otherwise noted.)

Parameter	Symbol	MIN.	TYP	MAX.	Unit	Condition
Quiescent Consumption Current	IQ	-	20	30	mA	No load applied
CH1, 2, 3 Standby IQST	IQST1	-	6.2	13	mA	No load applied (IQ of Pre only)
CH4 Standby IQST	IQST2	-	16	26	mA	No load applied (IQ of Pre only)
All CHs Standby IQST	IQST3	-	-	1	mA	No load applied (IQ of Pre only)
<Driver>						
Output Offset Voltage	VOOF	-70	0	70	mV	
Maximum Output Amplitude 1	VOM1	3.6	4.0	-	V	CH1,2 VIN=VBIAS ± 1.65V
Maximum Output Amplitude 2	VOM2	7.5	9	-	V	CH3,4 VIN=VBIAS ± 1.65V *
Voltage Gain 1	GVC1	10	12	14	dB	CH1,2 VIN=VBIAS ± 0.5V
Voltage Gain 2	GVC2	16	18	20	dB	CH3,4 VIN=VBIAS ± 0.5V *
Slew Rate	SRDRV	-	2	-	V/μs	Input square wave, 100kHz, 2V _{P-P}
Standby ON Voltage	VSTON	-	-	0.5	V	
Standby OFF Voltage	VSTOFF	2.0	-	-	V	
Bias Drop Mute ON Voltage	VBMON	-	-	0.7	V	
Bias Drop Mute OFF Voltage	VBMOFF	1.3	-	-	V	
<Pre-stage Operational Amplifier>						
Input Range (buffer in use)	VICM	0	-	9	V	
Input Offset Voltage	VOFOP	-6	0	6	mV	
Input Bias Current	VBOP	-	-	300	nA	
High-level Output Voltage	VOHOP	9	11	-	V	VBIAS=6V
Low-level Output Voltage	VOLOP	-	-	0.3	V	VBIAS=6V
Output Driving Current Sink	ISI	1	-	-	mA	VBIAS=6V VCC with 50Ω attached
Output Driving Current Source	ISO	300	500	-	μA	VBIAS=6V GND with 50Ω
Slew Rate	SROP	-	2	-	V/μs	Input square wave, 100kHz, 2V _{P-P}

○ OUTLINE DIMENSIONS, SYMBOLS

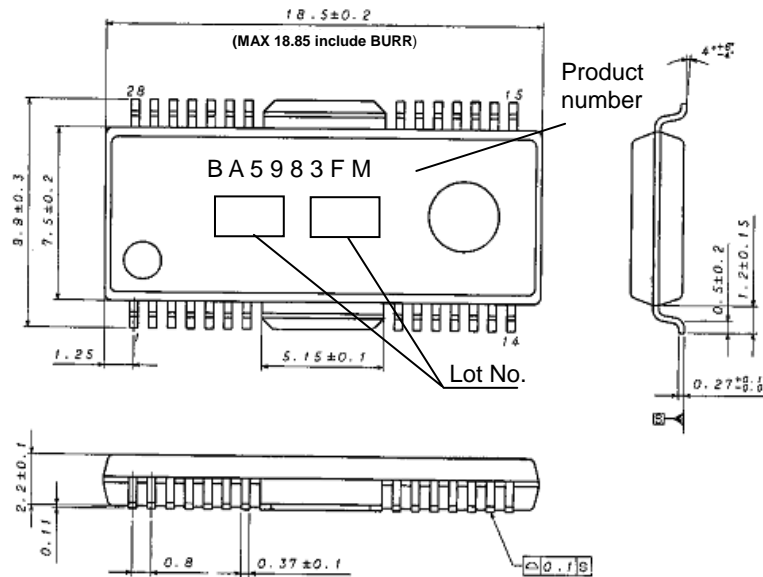

○ APPLICATION CIRCUIT DIAGRAM

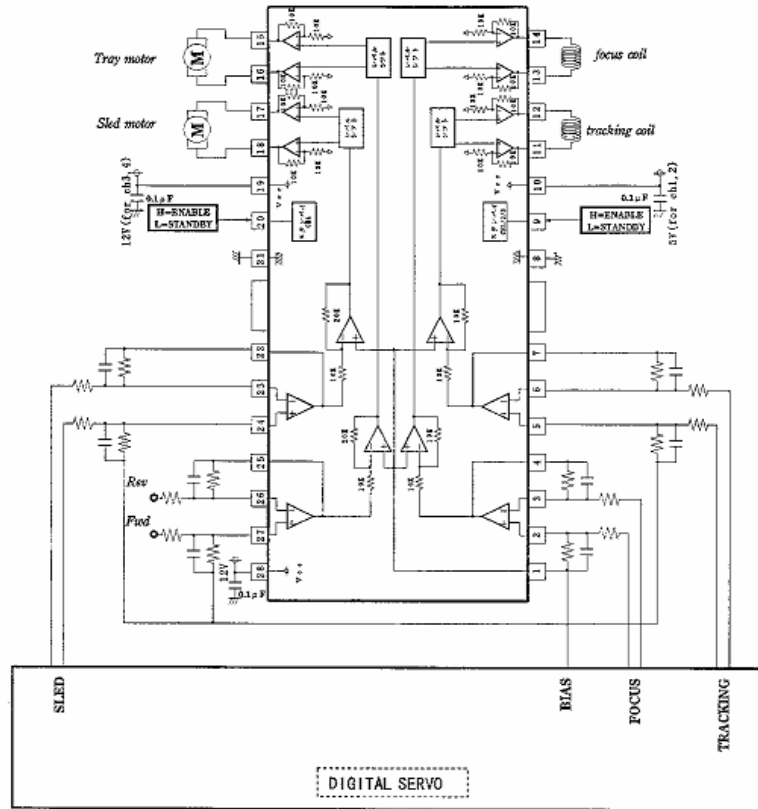

Resistance unit: [Ω]

○ PIN NUMBERS, PIN NAMES

No.	Pin Name	Description	No.	Pin Name	Description
1	BIASIN	Bias amp input terminal	15	VO4(+)	Driver CH4 positive output
2	OPIN1(+)	CH1 pre-stage amp non-inverted input terminal	16	VO4(-)	Driver CH4 negative output
3	OPIN1(-)	CH1 pre-stage amp inverted input terminal	17	VO3(+)	Driver CH3 positive output
4	OPOUT1	CH1 pre-stage amp output terminal	18	VO3(-)	Driver CH3 negative output
5	OPIN2(+)	CH2 pre-stage amp non-inverted input terminal	19	PowVcc2	PowVcc (CH3, 4)
6	OPIN2(-)	CH2 pre-stage amp inverted input terminal	20	STBY2	CH4 standby control terminal
7	OPOUT2	CH2 pre-stage amp output terminal	21	GND	GND
8	GND	GND	22	OPOUT3	CH3 pre-stage amp output terminal
9	STBY1	CH1 to 3 standby control terminal	23	OPIN3(-)	CH3 pre-stage amp inverted input terminal
10	PowVcc1	PowVcc (CH1,2)	24	OPIN3(+)	CH3 pre-stage amp non-inverted input terminal
11	VO2(-)	Driver CH2 negative output	25	OPOUT4	CH4 pre-stage amp output terminal
12	VO2(+)	Driver CH2 positive output	26	OPIN4(-)	CH4 pre-stage amp inverted input terminal
13	VO1(-)	Driver CH1 negative output	27	OPIN4(+)	CH4 pre-stage amp non-inverted input terminal
14	VO1(+)	Driver CH1 positive output	28	PreVcc	PreVcc

Note) The positive or negative polarity of driver outputs is determined by the input polarity. (For example, when the pre-stage OPAMP is used as a buffer, the pin 14 shows a same polarity output while the pin 13 an opposite polarity output.)

○ CAUTIONS ON USE

- (1) When the voltage applied on the Bias terminal (pin 1) has dropped to 0.7V (Typ.) or less, the mute function will be activated. Under conditions of normal use, it should be set to 1.3V or above.
- (2) When the power supply voltage drops to 3.8V (Typ.) or less, the internal circuit will be OFF and, when recovering to 4.0V (Typ.) or above, the circuit will startup again.
- (3) Thermal shutdown (TSD), bias terminal voltage drop or power supply voltage drop will activate the mute functions for the circuits in all channels, where the output terminals will show the value of the internal bias voltage ($V_{cc}/2$).
- (4) Setting the Standby terminal to open or 0.5V or less leads all the circuits in the channel to the standby mode. Under conditions of normal use, the Standby terminal should be pulled-up to 2V or above.
- (5) Setting both two Standby terminals to open or 0.5V or less allows the circuit current to be in the standby mode. The switched threshold voltage is approximately 1.4V.
- (6) V_{cc} of the pre part must be provided with the same voltage as V_{cc} of the power part or higher.
- (7) The source current of the pre-stage OP-amp is a constant current and the input resistance of the next-stage driver: 10k Ω is also internally connected as a load.
Careful consideration must be given when determining the external load resistance value of the OP-amp.
- (8) Even though a radiating fin is connected to the GND inside of the package, it must be connected to the external GND.
- (9) About absolute maximum ratings
Exceeding the absolute maximum ratings, such as the applied voltage or the operating temperature range, may cause permanent device damage. As these cases cannot be limited to the broken short mode or the open mode, if a special mode where the absolute maximum ratings may be exceeded is assumed, it is recommended to take mechanical safety measures such as attaching fuses.
- (10) About power supply lines
As a measure against the back current regenerated by a counter electromotive force of the motor, a capacitor to be used as a regenerated-current path can be installed between the power supply and GND and its capacitance value should be determined after careful check that any problems, for example, a leak capacitance of the electrolytic capacitor at low temperature, are not found in various characteristics.
- (11) About GND potential
The electric potential of the GND terminal must be kept lowest in the circuitry at any operation states.
- (12) About thermal design
With consideration of the power dissipation (P_d) under conditions of actual use, a thermal design provided with an enough margin should be done.
- (13) About operations in a strong electric field
When used in a strong electric field, note that a malfunction may occur.
- (14) ASO
When using this IC, the output T_r must be set not to exceed the values specified in the absolute maximum ratings and ASO.
- (15) Thermal shutdown circuit
This IC incorporates a thermal shutdown circuit (TSD circuit). When the chip temperature reaches the value shown below, the coil output to the motor will be set to open.
The thermal shutdown circuit is designed only to shut off the IC from a thermal runaway and not intended to protect or guarantee the entire IC functions.
Therefore, users cannot assume that the TSD circuit once activated can be used continuously in the subsequent operations.

TSD ON Temperature [°C] (typ.)	Hysteresis Temperature [°C] (typ.)
175	25

- (16) About earth wiring patterns
When a small signal GND and a large current GND are provided, it is recommended that the large current GND pattern and the small signal GND pattern should be separated and grounded at a single point of the reference point of the set in order to prevent the voltage of the small signal GND from being affected by a voltage change caused by the resistance of the pattern wiring and the large current. Make sure that the GND wiring patterns of the external components will not change, too.

- (17) This IC is a monolithic IC which has a P⁺ isolations and P substrate to isolate elements each other. This P layer and an N layer in each element form a PN junction to construct various parasitic elements. Due to the IC structure, the parasitic elements are inevitably created by the potential relationship. Activation of the parasitic elements can cause interference between circuits and may result in a malfunction or, consequently, a fatal damage. Therefore, make sure that the IC must not be used under conditions that may activate the parasitic elements, for example, applying the lower voltage than the ground level (GND, P substrate) to the input terminals.
- In addition, do not apply the voltage to input terminals without applying the power supply voltage to the IC. Also while applying the power supply voltage, the voltage of each input terminal must not be over the power supply voltage, or within the guaranteed values in the electric characteristics.

Notes

- No technical content pages of this document may be reproduced in any form or transmitted by any means without prior permission of ROHM CO.,LTD.
- The contents described herein are subject to change without notice. The specifications for the product described in this document are for reference only. Upon actual use, therefore, please request that specifications to be separately delivered.
- Application circuit diagrams and circuit constants contained herein are shown as examples of standard use and operation. Please pay careful attention to the peripheral conditions when designing circuits and deciding upon circuit constants in the set.
- Any data, including, but not limited to application circuit diagrams information, described herein are intended only as illustrations of such devices and not as the specifications for such devices. ROHM CO.,LTD. disclaims any warranty that any use of such devices shall be free from infringement of any third party's intellectual property rights or other proprietary rights, and further, assumes no liability of whatsoever nature in the event of any such infringement, or arising from or connected with or related to the use of such devices.
- Upon the sale of any such devices, other than for buyer's right to use such devices itself, resell or otherwise dispose of the same, no express or implied right or license to practice or commercially exploit any intellectual property rights or other proprietary rights owned or controlled by
- ROHM CO., LTD. is granted to any such buyer.
- Products listed in this document are no antiradiation design.

The products listed in this document are designed to be used with ordinary electronic equipment or devices (such as audio visual equipment, office-automation equipment, communications devices, electrical appliances and electronic toys).

Should you intend to use these products with equipment or devices which require an extremely high level of reliability and the malfunction of which would directly endanger human life (such as medical instruments, transportation equipment, aerospace machinery, nuclear-reactor controllers, fuel controllers and other safety devices), please be sure to consult with our sales representative in advance.

It is our top priority to supply products with the utmost quality and reliability. However, there is always a chance of failure due to unexpected factors. Therefore, please take into account the derating characteristics and allow for sufficient safety features, such as extra margin, anti-flammability, and fail-safe measures when designing in order to prevent possible accidents that may result in bodily harm or fire caused by component failure. ROHM cannot be held responsible for any damages arising from the use of the products under conditions out of the range of the specifications or due to non-compliance with the NOTES specified in this catalog.

Thank you for your accessing to ROHM product informations.

More detail product informations and catalogs are available, please contact your nearest sales office.

ROHM Customer Support System



THE AMERICAS / EUROPE / ASIA / JAPAN

www.rohm.com

Contact us : webmaster@rohm.co.jp

Looking for pricing, stock, or lifecycle information?

Click below to explore more details on WIN SOURCE:

-  [View BA5983FM-E2 on WIN SOURCE](#)
-  [Rohm Semiconductor](#) Information

Optimize Your Supply Chain with WIN SOURCE Solutions

-  Global Sourcing Solution
-  Obsolete Management
-  Cost Control Management
-  Shortage Management
-  Alternative Solution
-  Excess Inventory Management