



**THE DATASHEET OF
R1LP0408DSP-5SI#B0**



R1LP0408D Series

4Mb Advanced LPSRAM (512-kword × 8-bit)

R10DS0274EJ0200
Rev.2.00
2019.10.29

Description

The R1LP0408D Series is a family of 4-Mbit static RAMs organized 512-kword × 8-bit, fabricated by Renesas's high-performance CMOS and TFT technologies. The R1LP0408D Series has realized higher density, higher performance and low power consumption. The R1LP0408D Series offers low power standby power dissipation; therefore, it is suitable for battery backup systems. It is offered in 32-pin SOP and 32-pin TSOP.

Features

- Single 5V supply: 4.5V to 5.5V
- Access time: 55ns (max.)
- Power dissipation:
 - Standby: 4μW (typ.)
- Equal access and cycle times
- Common data input and output
 - Three state output
- Directly TTL compatible
 - All inputs and outputs
- Battery backup operation

Ordering Information

Orderable part name	Access time	Temperature range	Package	Shipping container
R1LP0408DSP-5SI#B*	55 ns	-40 ~ +85°C	525-mil 32-pin plastic SOP	Tube (Magazine)
R1LP0408DSP-5SI#S*				Embossed tape
R1LP0408DSB-5SI#B*			400-mil 32-pin plastic TSOP (II)	Tray
R1LP0408DSB-5SI#S*				Embossed tape

Note 1. * = Revision code for Assembly site change, etc. (* = 0, 1, etc.)

Pin Arrangement

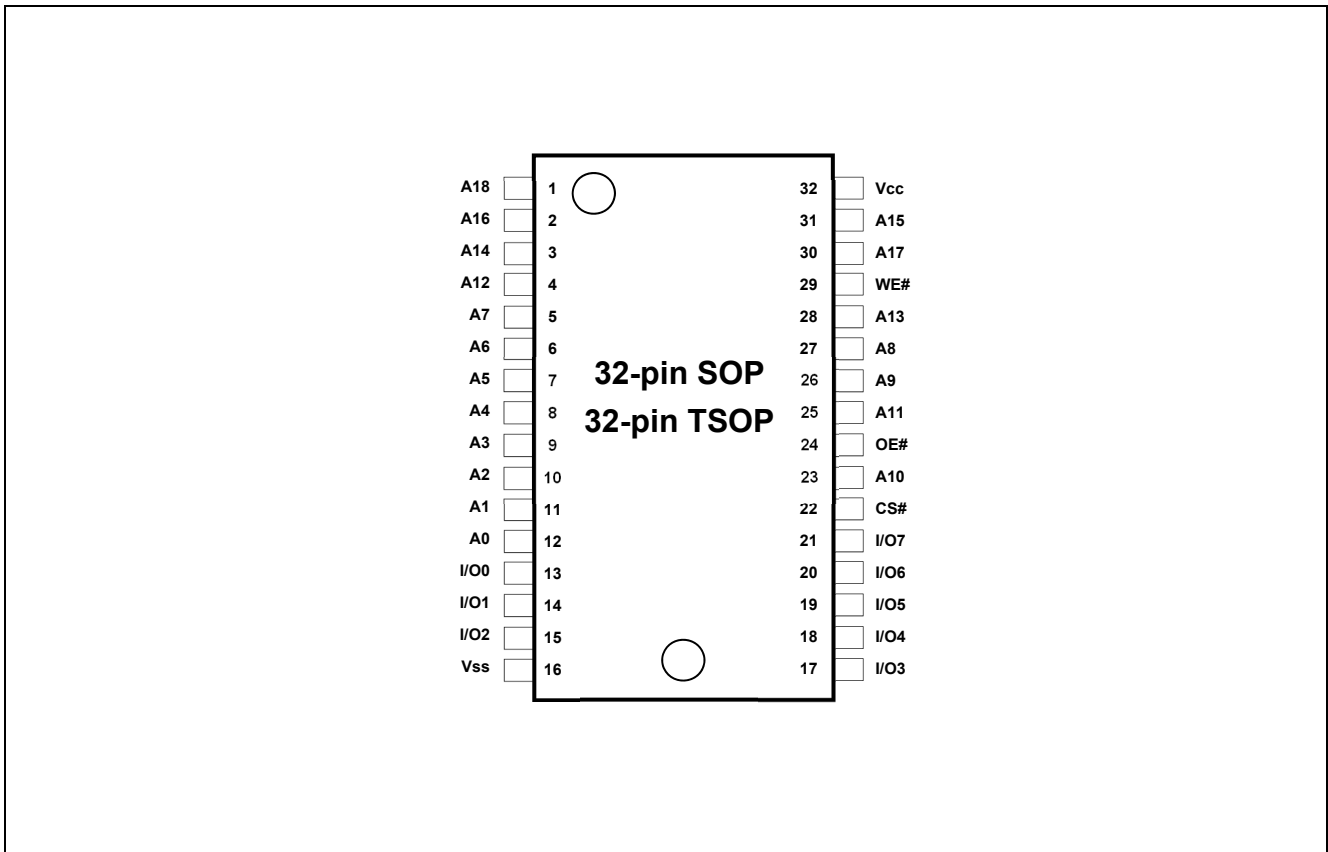

Pin Description

Pin name	Function
Vcc	Power supply
Vss	Ground
A0 to A18	Address input
I/O0 to I/O7	Data input/output
CS#	Chip select
WE#	Write enable
OE#	Output enable

Block Diagram

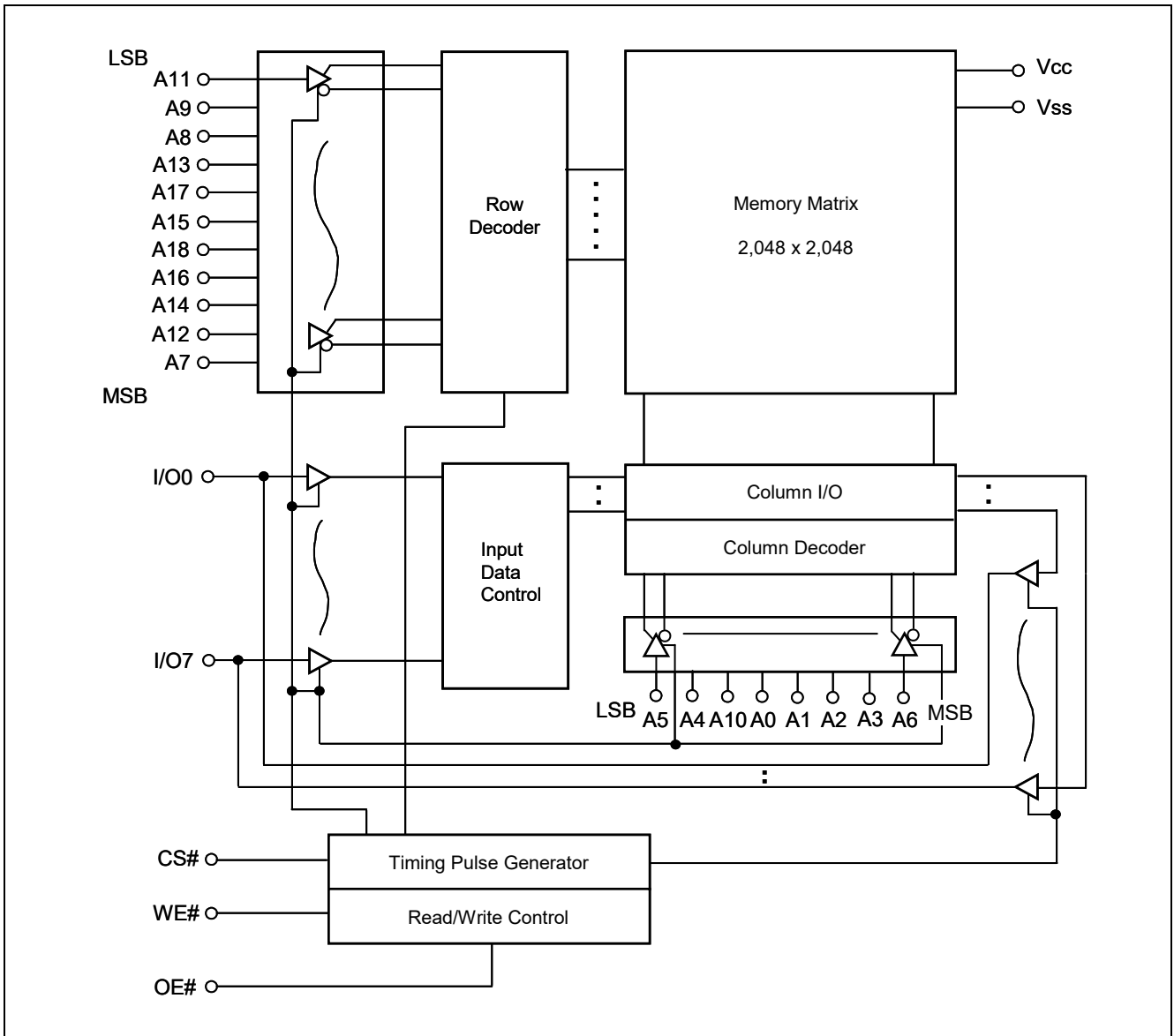

Operation Table

WE#	CS#	OE#	Mode	Vcc current	I/O0 to I/O7	Ref. cycle
x	H	x	Not selected	I_{SB}, I_{SB1}	High-Z	—
H	L	H	Output disable	I_{CC}	High-Z	—
H	L	L	Read	I_{CC}	Dout	Read cycle
L	L	H	Write	I_{CC}	Din	Write cycle (1)
L	L	L	Write	I_{CC}	Din	Write cycle (2)

Note 1. H: V_{IH} L: V_{IL} x: V_{IH} or V_{IL}

Absolute Maximum Ratings

Parameter	Symbol	Value	unit
Power supply voltage relative to Vss	Vcc	-0.5 to +7.0	V
Terminal voltage on any pin relative to Vss	V_T	-0.5^{*1} to $V_{CC}+0.3^{*2}$	V
Power dissipation	P_T	0.7	W
Operation temperature	T_{opr}	-40 to +85	°C
Storage temperature range	T_{stg}	-65 to 150	°C
Storage temperature range under bias	T_{bias}	-40 to +85	°C

Note 1. -3.0V for pulse \leq 30ns (full width at half maximum)
 2. Maximum voltage is +7.0V.

DC Operating Conditions

Parameter	Symbol	Min.	Typ.	Max.	Unit	Note
Supply voltage	V _{CC}	4.5	5.0	5.5	V	
	V _{SS}	0	0	0	V	
Input high voltage	V _{IH}	2.2	—	V _{CC} +0.3	V	
Input low voltage	V _{IL}	-0.3	—	0.8	V	1
Ambient temperature range	T _a	-40	—	+85	°C	

Note 1. -3.0V for pulse ≤ 30ns (full width at half maximum)

DC Characteristics

Parameter	Symbol	Min.	Typ.	Max.	Unit	Test conditions	
Input leakage current	I _{LI}	—	—	1	μA	V _{in} = V _{SS} to V _{CC}	
Output leakage current	I _{LO}	—	—	1	μA	CS# = V _{IH} or OE# = V _{IH} , V _{I/O} = V _{SS} to V _{CC}	
Operating current	I _{CC}	—	5 ^{*1}	10	mA	CS# = V _{IL} , Others = V _{IH} /V _{IL} , I _{I/O} = 0mA	
Average operating current	I _{CC1}	—	15 ^{*1}	25	mA	Min. cycle, duty = 100%, I _{I/O} = 0mA, CS# = V _{IL} , Others = V _{IH} /V _{IL}	
	I _{CC2}	—	3 ^{*1}	5	mA	Cycle = 1μs, duty = 100%, I _{I/O} = 0mA, CS# ≤ 0.2V, V _{IH} ≥ V _{CC} -0.2V, V _{IL} ≤ 0.2V	
Standby current	I _{SB}	—	0.1 ^{*1}	0.5	mA	CS# = V _{IH} , Others = V _{SS} to V _{CC}	
Standby current	I _{SB1}	—	0.8 ^{*1}	2.5	μA	~+25°C	V _{in} = V _{SS} to V _{CC} , CS# ≥ V _{CC} -0.2V
		—	1 ^{*2}	3	μA	~+40°C	
		—	—	8	μA	~+70°C	
		—	—	10	μA	~+85°C	
Output high voltage	V _{OH}	2.4	—	—	V	I _{OH} = -1mA	
	V _{OH2}	V _{CC} -0.5	—	—	V	I _{OH} = -0.1mA	
Output low voltage	V _{OL}	—	—	0.4	V	I _{OL} = 2.1mA	

Note 1. Typical parameter indicates the value for the center of distribution at 5.0V (T_a=25°C), and not 100% tested.

2. Typical parameter indicates the value for the center of distribution at 5.0V (T_a=40°C), and not 100% tested.

Capacitance

(V_{CC} = 4.5V ~ 5.5V, f = 1MHz, T_a = -40 ~ +85°C)

Parameter	Symbol	Min.	Typ.	Max.	Unit	Test conditions	Note
Input capacitance	C _{in}	—	—	8	pF	V _{in} = 0V	1
Input / output capacitance	C _{I/O}	—	—	10	pF	V _{I/O} = 0V	1

Note 1. This parameter is sampled and not 100% tested.

AC Characteristics

Test Conditions ($V_{CC} = 4.5V \sim 5.5V$, $T_a = -40 \sim +85^{\circ}C$)

- Input pulse levels: $V_{IL} = 0.4V$, $V_{IH} = 2.4V$
- Input rise and fall time: 5ns
- Input and output timing reference level: 1.5V
- Output load: See figures (Including scope and jig)

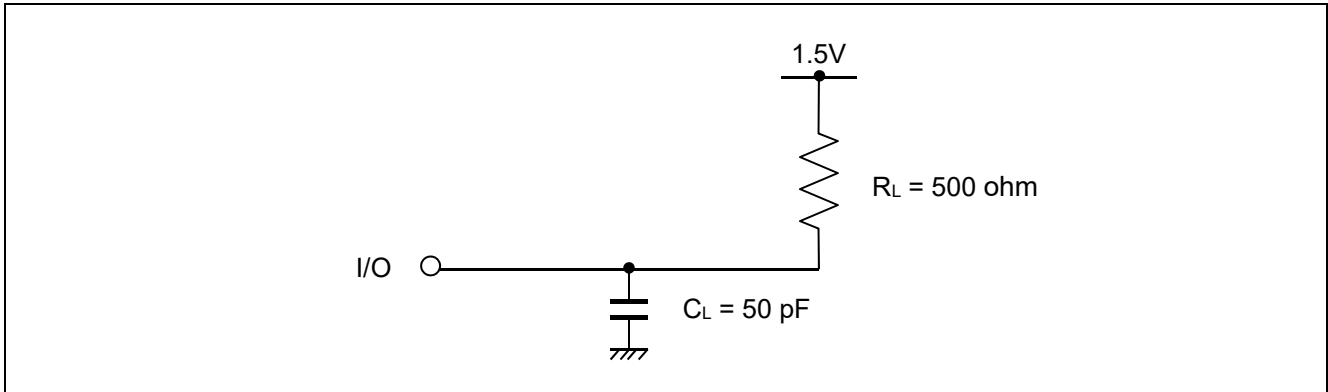

Read Cycle

Parameter	Symbol	Min.	Max.	Unit	Note
Read cycle time	t _{RC}	55	—	ns	
Address access time	t _{AA}	—	55	ns	
Chip select access time	t _{ACS}	—	55	ns	
Output enable to output valid	t _{OE}	—	25	ns	
Chip select to output in low-Z	t _{CLZ}	10	—	ns	2
Output enable to output in low-Z	t _{OLZ}	5	—	ns	2
Chip deselect to output in high-Z	t _{CHZ}	0	20	ns	1,2
Output disable to output in high-Z	t _{OHZ}	0	20	ns	1,2
Output hold from address change	t _{OH}	10	—	ns	

Write Cycle

Parameter	Symbol	Min.	Max.	Unit	Note
Write cycle time	t _{WC}	55	—	ns	
Chip select to end of write	t _{CW}	50	—	ns	4
Address setup time	t _{AS}	0	—	ns	5
Address valid to end of write	t _{AW}	50	—	ns	
Write pulse width	t _{WP}	40	—	ns	3,12
Write recovery time	t _{WR}	0	—	ns	6
Write to output in high-Z	t _{WHZ}	0	20	ns	1,2,7
Data to write time overlap	t _{DW}	25	—	ns	
Data hold from write time	t _{DH}	0	—	ns	
Output enable from end of write	t _{OW}	5	—	ns	2
Output disable to output in high-Z	t _{OHZ}	0	20	ns	1,2,7

- Note
- t_{CHZ}, t_{OHZ} and t_{WHZ} are defined as the time at which the outputs achieve the open circuit conditions and are not referred to output voltage levels.
 - This parameter is sampled and not 100% tested.
 - A write occurs during the overlap (t_{WP}) of a low CS# and a low WE#.
A write begins at the later transition of CS# going low or WE# going low.
A write ends at the earlier transition of CS# going high or WE# going high.
t_{WP} is measured from the beginning of write to the end of write.
 - t_{CW} is measured from CS# going low to end of write.
 - t_{AS} is measured the address valid to the beginning of write.
 - t_{WR} is measured from the earlier of WE# or CS# going high to the end of write cycle.
 - During this period, I/O pins are in the output state so that the input signals of the opposite phase to the outputs must not be applied.
 - If the CS# low transition occurs simultaneously with the WE# low transition or after the WE# transition, the output remain in a high impedance state.
 - Dout is the same phase of the write data of this write cycle.
 - Dout is the read data of next address.
 - If CS# is low during this period, I/O pins are in the output state. Therefore, the input signals of the opposite phase to the outputs must not be applied to them.
 - In the write cycle with OE# low fixed, t_{WP} must satisfy the following equation to avoid a problem of data bus contention.
t_{WP} ≥ t_{DW} min + t_{WHZ} max

Timing Waveforms

Read Cycle (WE# = V_{IH})

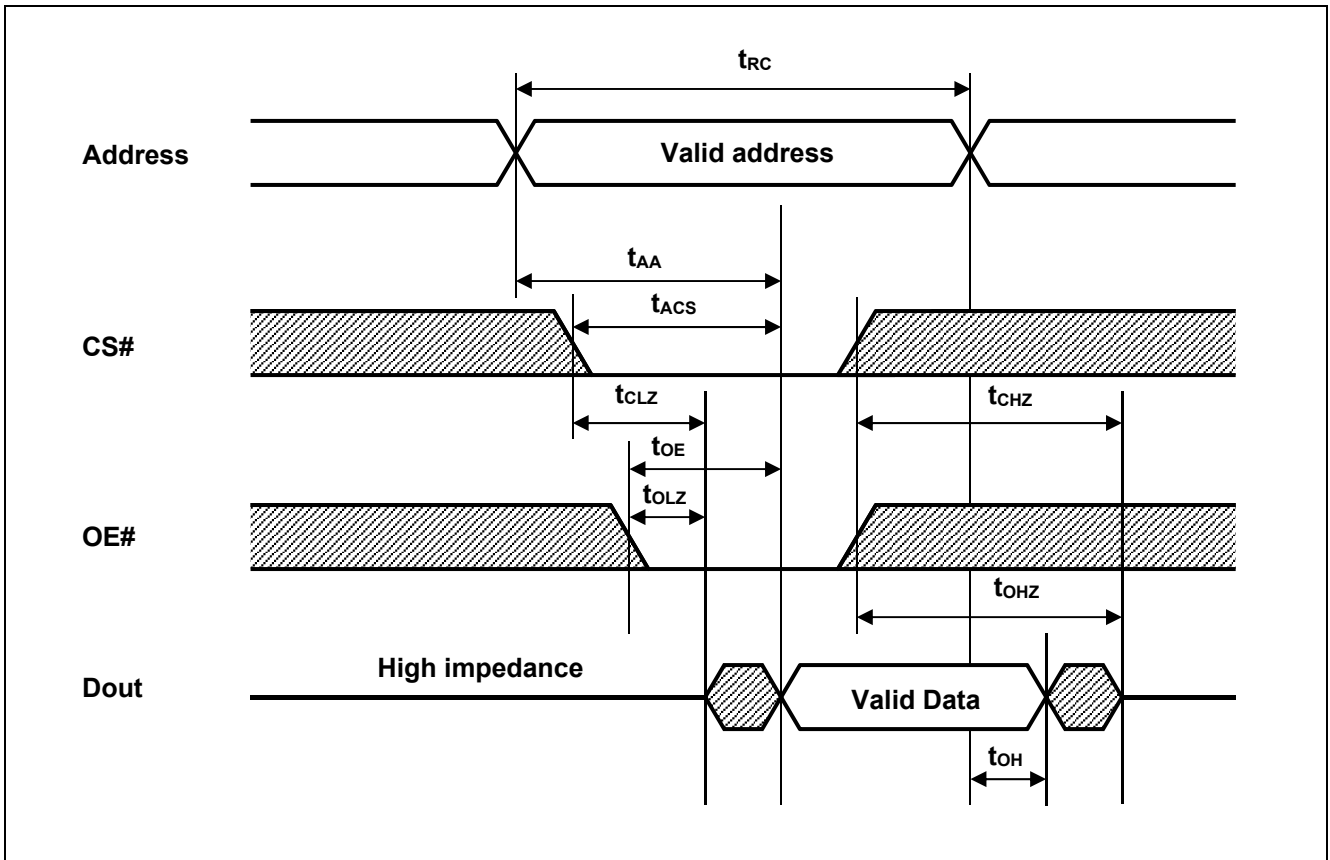

Write Cycle (1) (OE# CLOCK)

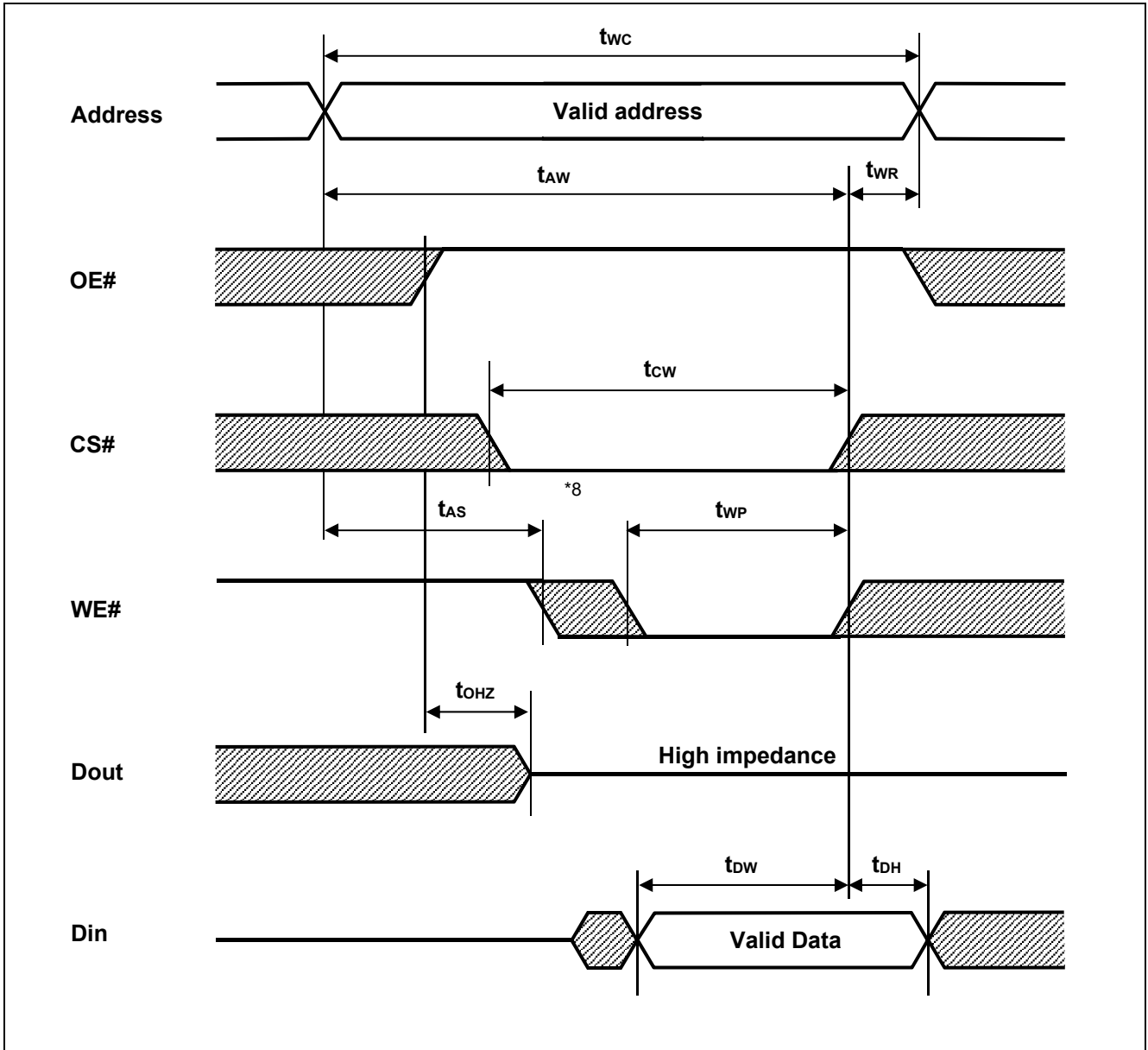

Write Cycle (2) (OE# Low Fixed)

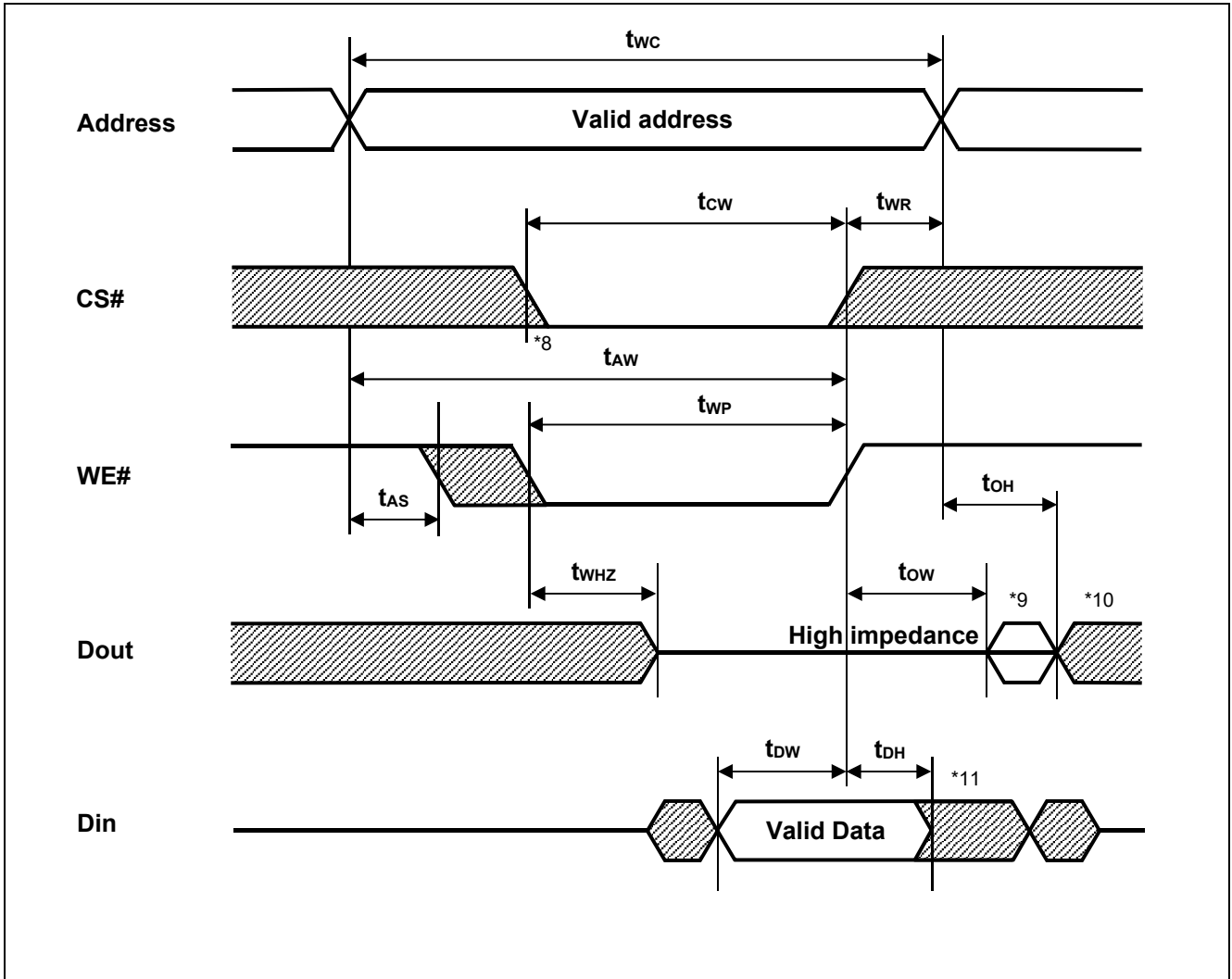

Low Vcc Data Retention Characteristics

Parameter	Symbol	Min.	Typ.	Max.	Unit	Test conditions ³	
V _{CC} for data retention	V _{DR}	2.0	—	5.5	V	V _{in} ≥ 0V, CS# ≥ V _{CC} -0.2V	
Data retention current	I _{CCDR}	—	0.8 ¹	2.5	μA	~+25°C	V _{CC} =3.0V, V _{in} ≥ 0V, CS# ≥ V _{CC} -0.2V
		—	1 ²	3	μA	~+40°C	
		—	—	8	μA	~+70°C	
		—	—	10	μA	~+85°C	
Chip deselect time to data retention	t _{CDR}	0	—	—	ns	See retention waveform.	
Operation recovery time	t _R	5	—	—	ms		

- Note
1. Typical parameter indicates the value for the center of distribution at 3.0V (T_a=25°C), and not 100% tested.
 2. Typical parameter indicates the value for the center of distribution at 3.0V (T_a=40°C), and not 100% tested.
 3. CS# controls address buffer, WE# buffer, OE# buffer and Din buffer. If data retention mode, V_{in} levels (address, WE#, OE#, I/O) can be in the high impedance state.

Low Vcc Data Retention Timing Waveforms

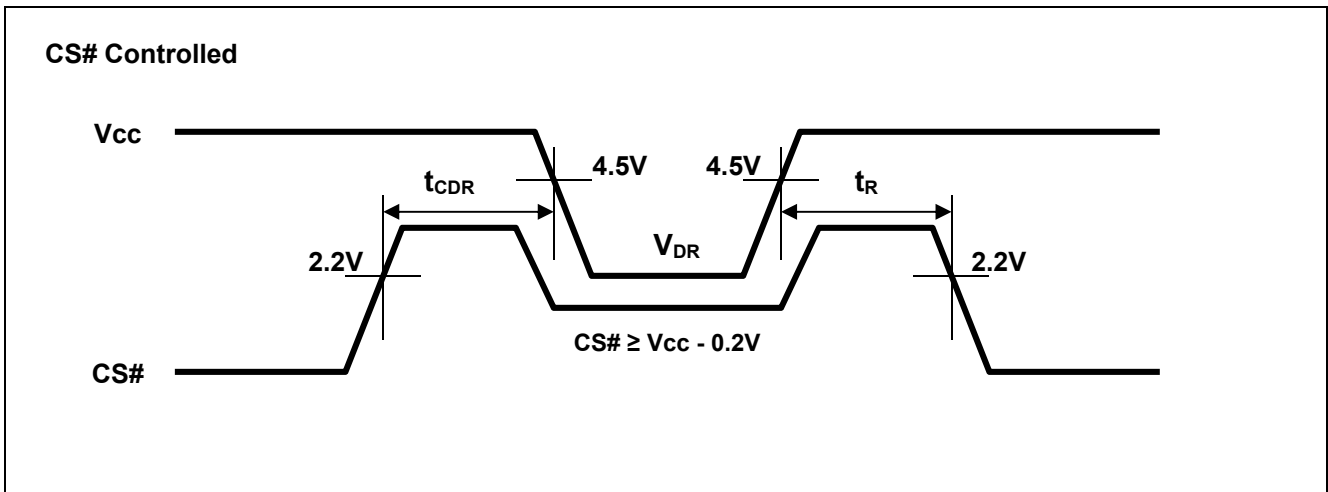

Revision History	R1LP0408D Series Data Sheet
------------------	-----------------------------

Rev.	Date	Description	
		Page	Summary
1.00	2017.1.27	—	First Edition issued
2.00	2019.10.29	p.1	Revised orderable part name information.

IMPORTANT NOTICE AND DISCLAIMER

RENESAS ELECTRONICS CORPORATION AND ITS SUBSIDIARIES (“RENESAS”) PROVIDES TECHNICAL SPECIFICATIONS AND RELIABILITY DATA (INCLUDING DATASHEETS), DESIGN RESOURCES (INCLUDING REFERENCE DESIGNS), APPLICATION OR OTHER DESIGN ADVICE, WEB TOOLS, SAFETY INFORMATION, AND OTHER RESOURCES “AS IS” AND WITH ALL FAULTS, AND DISCLAIMS ALL WARRANTIES, EXPRESS OR IMPLIED, INCLUDING, WITHOUT LIMITATION, ANY IMPLIED WARRANTIES OF MERCHANTABILITY, FITNESS FOR A PARTICULAR PURPOSE, OR NON-INFRINGEMENT OF THIRD PARTY INTELLECTUAL PROPERTY RIGHTS.

These resources are intended for developers skilled in the art designing with Renesas products. You are solely responsible for (1) selecting the appropriate products for your application, (2) designing, validating, and testing your application, and (3) ensuring your application meets applicable standards, and any other safety, security, or other requirements. These resources are subject to change without notice. Renesas grants you permission to use these resources only for development of an application that uses Renesas products. Other reproduction or use of these resources is strictly prohibited. No license is granted to any other Renesas intellectual property or to any third party intellectual property. Renesas disclaims responsibility for, and you will fully indemnify Renesas and its representatives against, any claims, damages, costs, losses, or liabilities arising out of your use of these resources. Renesas' products are provided only subject to Renesas' Terms and Conditions of Sale or other applicable terms agreed to in writing. No use of any Renesas resources expands or otherwise alters any applicable warranties or warranty disclaimers for these products.

(Rev.1.0 Mar 2020)

Corporate Headquarters

TOYOSU FORESIA, 3-2-24 Toyosu,
Koto-ku, Tokyo 135-0061, Japan
www.renesas.com

Contact Information

For further information on a product, technology, the most up-to-date version of a document, or your nearest sales office, please visit:
www.renesas.com/contact/

Trademarks

Renesas and the Renesas logo are trademarks of Renesas Electronics Corporation. All trademarks and registered trademarks are the property of their respective owners.

Looking for pricing, stock, or lifecycle information?

Click below to explore more details on WIN SOURCE:

- [View R1LP0408DSP-5SI#B0 on WIN SOURCE](#)
- [Renesas Electronics America Information](#)

Optimize Your Supply Chain with WIN SOURCE Solutions

- ✓ Global Sourcing Solution
- ✓ Obsolete Management
- ✓ Cost Control Management
- ✓ Shortage Management
- ✓ Alternative Solution
- ✓ Excess Inventory Management