



**THE DATASHEET OF  
BA5970FP-E2**



# 4-channel BTL driver for CD players and CD-ROMs

## BA5970FP

The BA5970FP is a 4-channel BTL driver developed to drive CD player motors and actuators. The driver input stage contains an operational amplifier, supports a variety of input formats, and allows simple configuration of a filter.

### ●Applications

CD players, CD-ROM

### ●Features

- 1) 4-channel BTL driver.
- 2) Wide dynamic range (4V when  $PREV_{CC} = 8V$ ,  $POWV_{CC} = 5V$ , and  $R_L = 8\Omega$ ).
- 3) Internal thermal shutdown circuit.
- 4) Driver gain is adjustable with externally connected resistor.
- 5) Independent power supplies  $PREV_{CC}$ ,  $POWV_{CC}$  (for channels 1 and 2), and  $POWV_{CC}$  (for channels 3 and 4), and low voltage operation for a highly efficient drive.
- 6) Independent mute pins for channels 1 and 2 and channels 3 and 4.
- 7) Perfect for compact applications with the use of the HSOP28-pin power package.

### ●Absolute maximum ratings ( $T_a = 25^\circ\text{C}$ )

Parameter	Symbol	Limits	Unit
Power supply voltage	$PREV_{CC}$ , $POWV_{CC}$	13.5	V
Power dissipation	$P_d$	1.7* <sup>1</sup>	W
Operating temperature	$T_{opr}$	$-35 \sim +85$	$^\circ\text{C}$
Storage temperature	$T_{stg}$	$-55 \sim +150$	$^\circ\text{C}$

\*1 When mounted on a 70mm × 70mm × 1.6mm glass epoxy board with copper foil coverage of less than 3%.  
Reduced by 13.6mW for each increase in  $T_a$  of  $1^\circ\text{C}$  over  $25^\circ\text{C}$ .

### ●Recommended operating conditions ( $T_a = 25^\circ\text{C}$ )

Parameter	Symbol	Limits	Unit
Power supply voltage	$PREV_{CC}$	4.5~13.2	V
	$POWV_{CC}$	4.5~ $PREV_{CC}$	V

## ● Block diagram

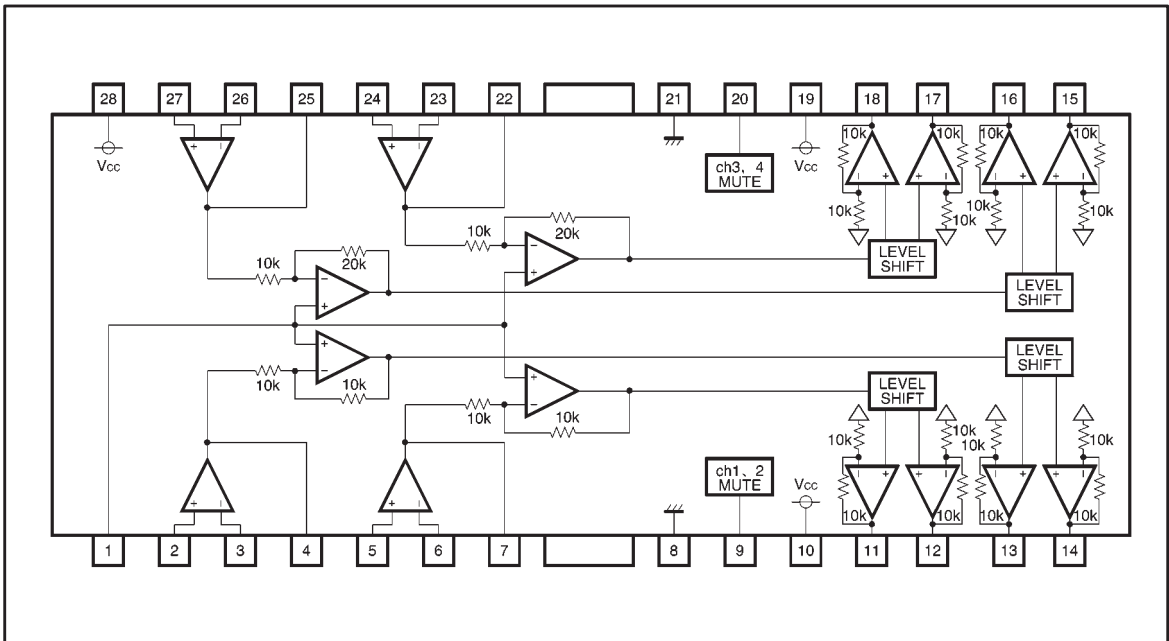

## ● Pin descriptions

Pin No.	Pin name	Function	Pin No.	Pin name	Function
1	BIAS IN	Bias amplifier input	15	VO4 (+)	Driver channel 4 positive output
2	OPIN1 (+)	Channel 1 pre-amplifier non-inverse input	16	VO4 (-)	Driver channel 4 negative output
3	OPIN1 (-)	Channel 1 pre-amplifier inverse input	17	VO3 (+)	Driver channel 3 positive output
4	OPOUT1	Channel 1 pre-amplifier output	18	VO3 (-)	Driver channel 3 negative output
5	OPIN2 (+)	Channel 2 pre-amplifier non-inverse input	19	POWVcc	POWVcc (channels 3 and 4)
6	OPIN2 (-)	Channel 2 pre-amplifier inverse input	20	MUTE2	Mute control for channels 3 and 4
7	OPOUT2	Channel 2 pre-amplifier output pin	21	GND	GND
8	GND	GND	22	OPOUT3	Channel 3 pre-amplifier output
9	MUTE1	Mute control for channels 1 and 2	23	OPIN3 (-)	Channel 3 pre-amplifier inverse input
10	POWVcc	POWVcc (channels 1 and 2)	24	OPIN3 (+)	Channel 3 pre-amplifier non-inverse input
11	VO2 (-)	Driver channel 2 negative output	25	OPOUT4	Channel 4 pre-amplifier output
12	VO2 (+)	Driver channel 2 positive output	26	OPIN4 (-)	Channel 4 pre-amplifier inverse input
13	VO1 (-)	Driver channel 1 negative output	27	OPIN4 (+)	Channel 4 pre-amplifier non-inverse input
14	VO1 (+)	Driver channel 1 positive output	28	PREVcc	PREVcc

Note : Positive output and negative output are the polarities with respect to the input.  
(For example, if pin 4 voltage is high, then pin 14 voltage becomes high.)

● Input / output circuits

Pre-amplifier input

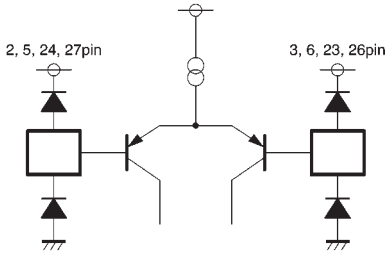

Driver output

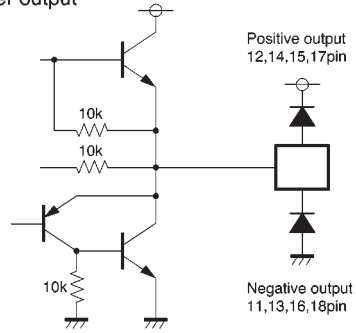

Pre-amplifier output (driver input)

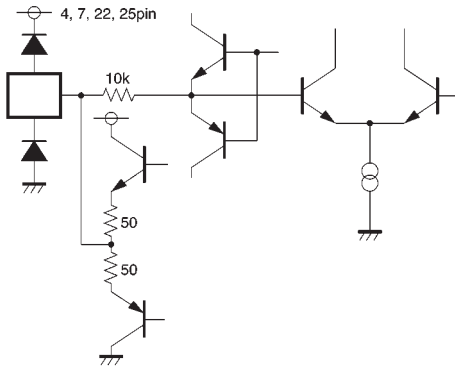

Mute

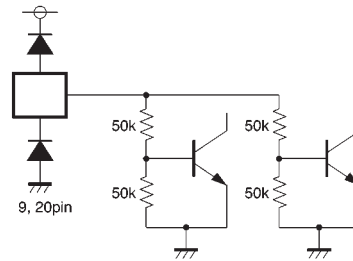

Bias

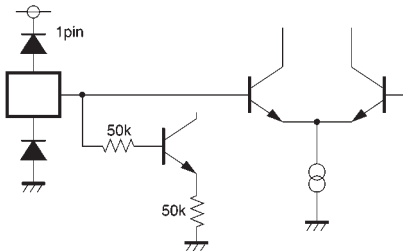

- Electrical characteristics (unless otherwise noted,  $T_a = 25^\circ\text{C}$ ,  $\text{PREV}_{\text{CC}} = 8\text{V}$ ,  $\text{POWV}_{\text{CC}1} = 5\text{V}$ ,  $\text{POWV}_{\text{CC}2} = 8\text{V}$ ,  $\text{BIAS} = 2.5\text{V}$ ,  $R_L = 8\Omega$ )

Parameter	Symbol	Min.	Typ.	Max.	Unit	Conditions
Quiescent current	$I_{Q1}$	—	20	30	mA	Input open
〈Driver〉						
Output offset voltage 1	$V_{OO1}$	−70	0	70	mV	channel 1, 2
Output offset voltage 2	$V_{OO2}$	−90	0	90	mV	channel 3, 4
Maximum output amplitude 1	$V_{OM1}$	3.6	4.0	—	V	channel 1, 2, $V_{IN} = \pm 2.0\text{V}$
Maximum output amplitude 2	$V_{OM2}$	5.4	6.0	—	V	channel 3, 4, $V_{IN} = \pm 2.0\text{V}$
Voltage gain 1	$GV_{C1}$	10	12	14	dB	$V_{IN} = \pm 0.5\text{V}$
Voltage gain 2	$GV_{C2}$	16	18	20	dB	$V_{IN} = \pm 0.5\text{V}$
Mute on voltage	$V_{MON}$	2.0	—	—	V	
Mute off voltage	$V_{MOFF}$	—	—	0.5	V	
〈Pre-stage operational amplifier〉						
Common-mode input voltage	$V_{ICM}$	−0.3	—	6.8	mV	
Offset voltage	$V_{OFOP}$	−6	0	6	mV	
Input bias current	$V_{BOP}$	—	—	300	nA	
Output high level voltage	$V_{OHOP}$	6.9	7.35	—	V	
Output low level voltage	$V_{OLOP}$	—	0.75	1.1	V	
Output drive current sink	$I_{SI}$	1	—	—	mA	$50\Omega$ at $V_{CC}$
Output drive current source	$I_{SO}$	1	—	—	mA	$50\Omega$ at GND
Slew rate	$SR_{OP}$	—	1	—	$\text{V}/\mu\text{s}$	100kHz rectangular wave, $2V_{P-P}$ output

©Not designed for radiation resistance.

● Measurement circuit

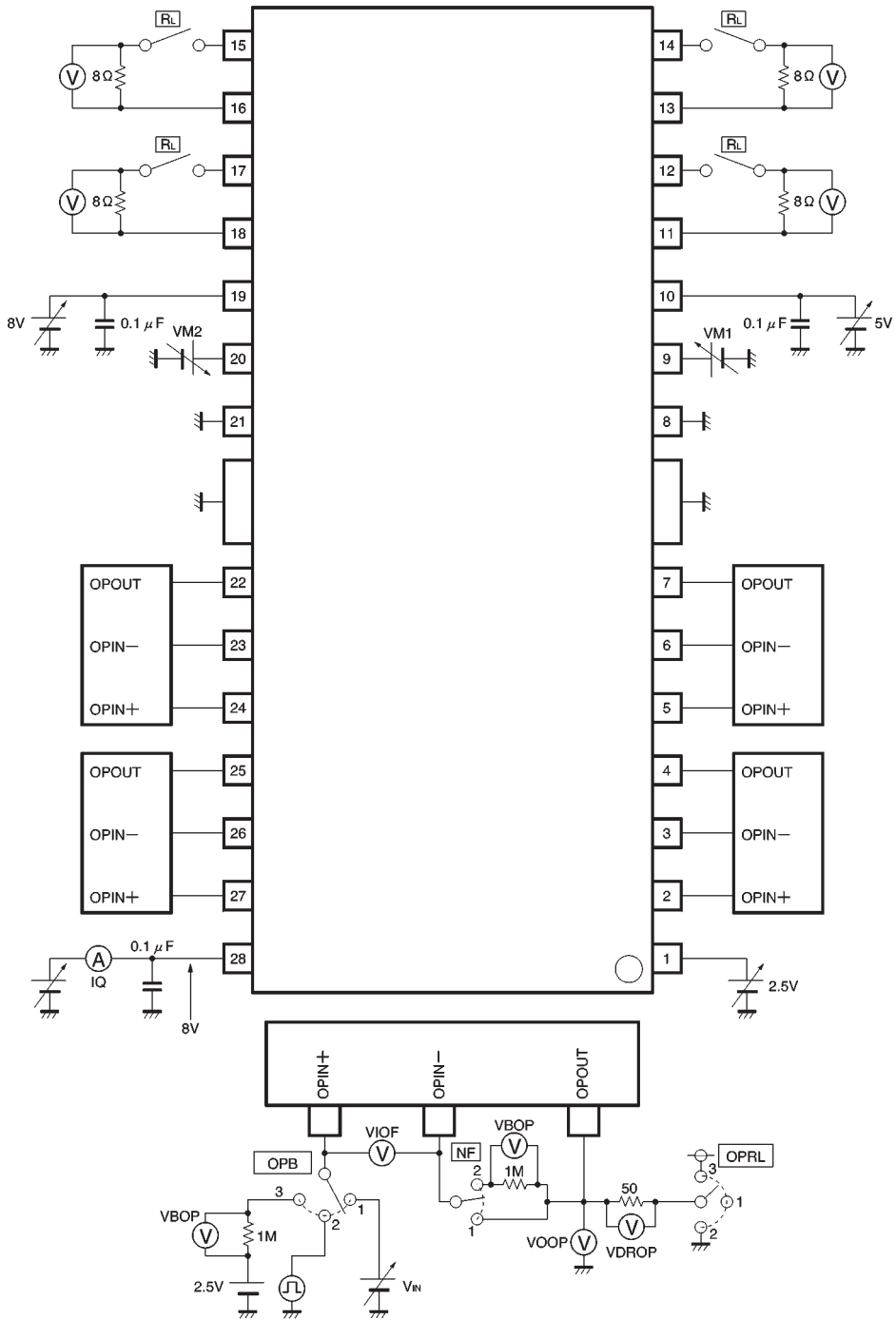

Fig.1

## ● Measurement circuit switch table

(1) Driver block (OPB → 1, NF → 1, OPRL → 1)

Symbol	Switch	Input		Remarks	Measurement point
	RL	V <sub>IN</sub>	VM1, 2		
IQ	OFF	2.5V	0V	—	IQ
VOO1	ON	2.5V	0.5V	—	VO (channel 1, 2)
VOO2	ON	2.5V	0.5V	—	VO (channel 3, 4)
VOOM1	ON	±2.0V	0.5V	V <sub>IN</sub> =0.5V and 4.5V	VO (channel 1, 2)
VOOM2	ON	±2.0V	0.5V	V <sub>IN</sub> =0.5V and 4.5V	VO (channel 3, 4)
GVC1	ON	±0.5V	0.5V	V <sub>IN</sub> =2.0V and 3.0V	VO (channel 1, 2)
GVC2	ON	±0.5V	0.5V	V <sub>IN</sub> =2.0V and 3.0V	VO (channel 3, 4)
VMTON	ON	3.0V	2.0V	Verify output voltage is muted	VO
VMTOFF	ON	3.0V	0.5V	Verify output voltage is muted	VO

(2) Pre-stage operational amplifier block (VN1 = VM2 = 0V, RL → OFF)

Symbol	Switch			Input	Remarks	Measurement point
	OPB	NF	OPRL	V <sub>IN</sub>		
VOFOP	1	1	1	2.5V	—	VIOF
VBOP	3	2	1	2.5V	—	VBOP/1MΩ
VOHOP	1	1	1	5V	—	VOOP
VOLOP	1	1	1	0V	—	VOOP
ISI	1	1	3	2.5V	—	VDROP/50Ω
ISO	1	1	2	2.5V	—	VDROP/50Ω
SROP	2	1	1	±1V	100kHz rectangular wave, 2.5±1V input	VOOP

●Application example

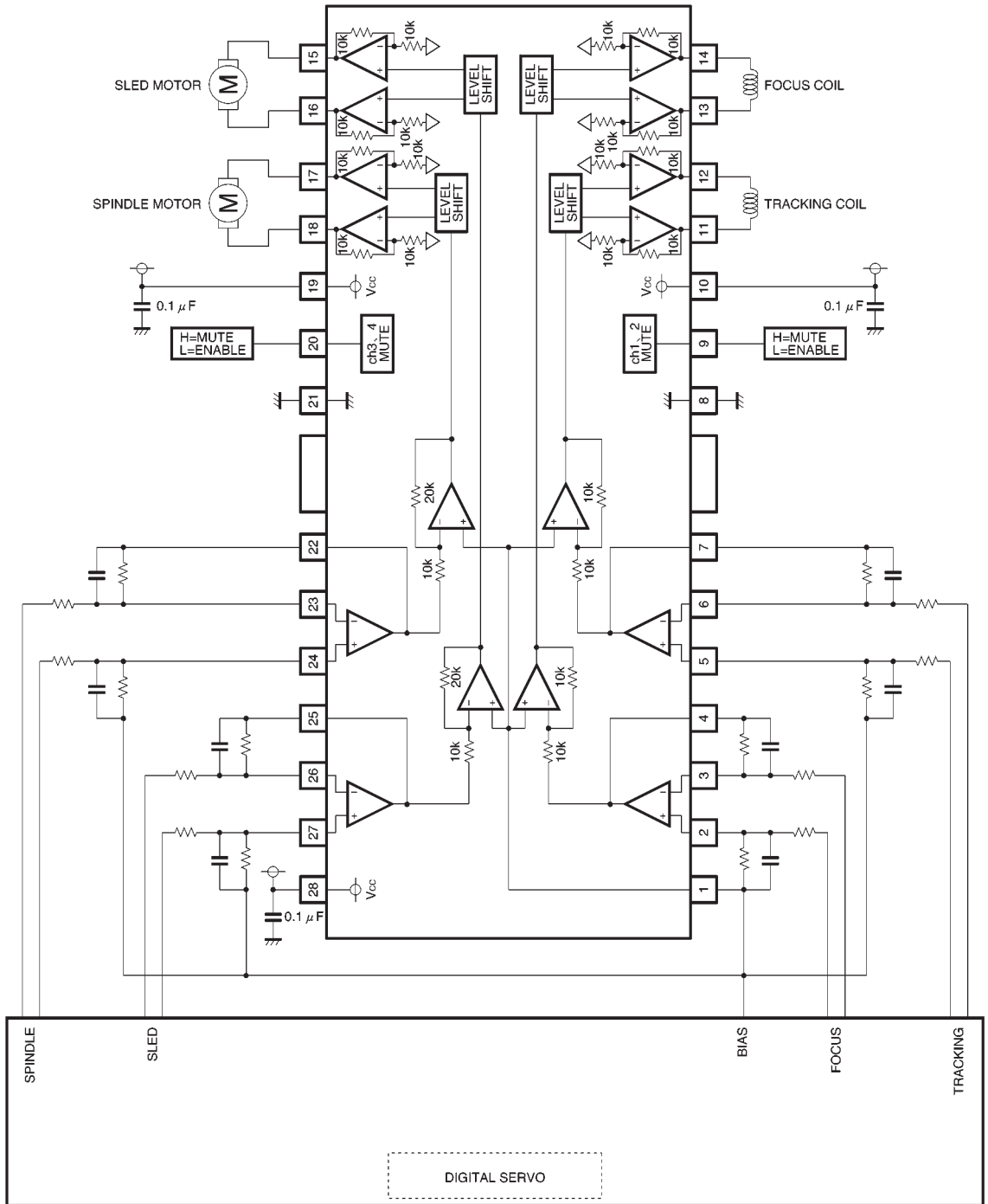

Fig.2

● Operation notes

- (1) The BA5970FP contains a thermal shutdown circuit. When the chip temperature reaches 175°C (Typ.), the output current is muted. If the chip temperature then drops below 150°C (Typ.), then the mute is released.
- (2) By having the mute pin voltage pulled up to 2.0V or greater, you can mute the output current. For normal conditions, have mute pin open or at 0.5V or below. (Pin 9 mutes channels 1 and 2, and pin 20 mutes channels 3 and 4.)
- (3) If the voltage of the bias pin (pin 1) drops below 1.4V (Typ.), outputs are muted. For normal conditions, have the voltage above 1.7V.
- (4) If the power supply voltage drops below 3.8V (Typ.),

- internal circuits turns off. If the power supply voltage then rises to 4.0V (Typ.), the circuits turn on.
- (5) If the voltage of the thermal shutdown, mute ON, or bias pin drops, or if the power supply voltage drops, the mute is activated; however, in these situations, only the drivers are muted. Also, the output pin voltage becomes the internal bias voltage (approx.  $V_{CC}/2$  for channels 1 and 2, and  $(V_{CC}-V_F)/2$  for channels 3 and 4).
- (6) Connect a bypass capacitor (approx. 0.1μF) between the bases of the power supply pins of this IC.
- (7) Even though the radiation fins are connected to ground within the package, be sure to also connect them to a ground externally as well.

● Electrical characteristic curves

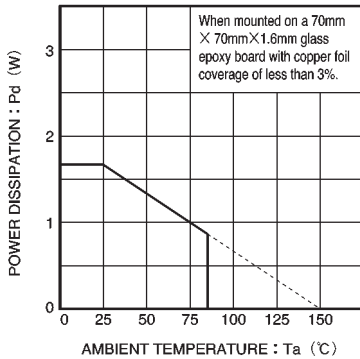

Fig.3 Thermal derating curve

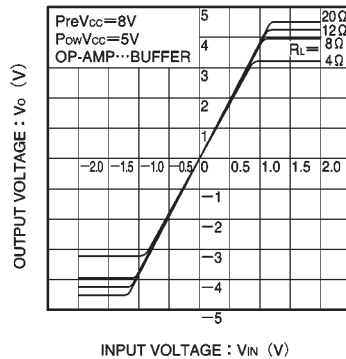

Fig.4 I/O characteristics (channels 1 and 2)

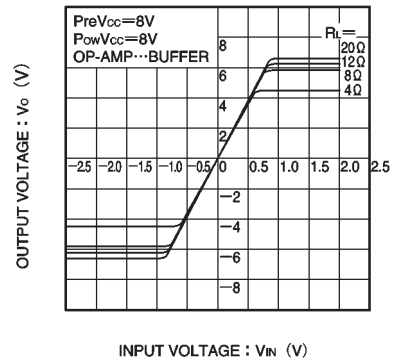

Fig.5 I/O characteristics (channels 3 and 4)

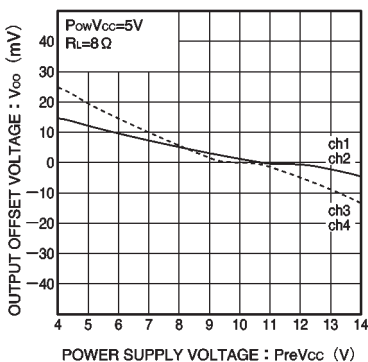

Fig.6 Power supply voltage vs. output offset voltage

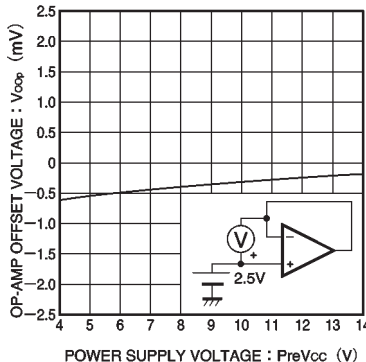

Fig.7 Power supply voltage vs. operational amplifier offset voltage

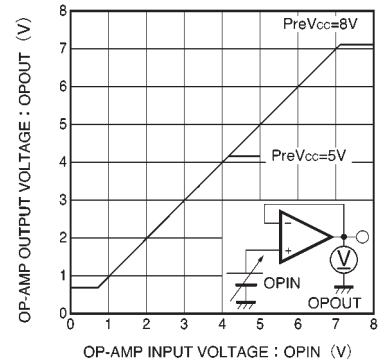
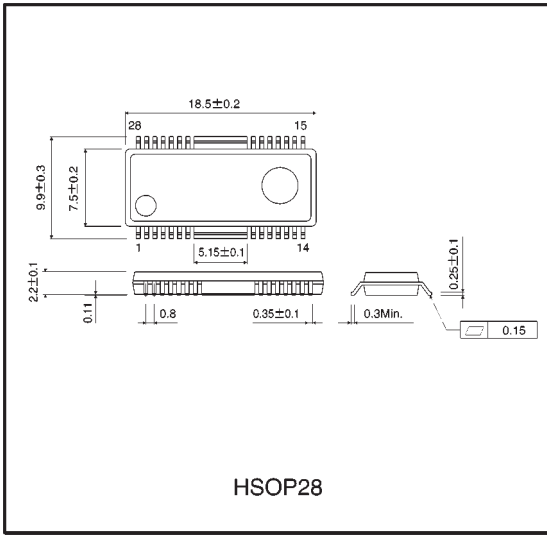



Fig.8 Operational amplifier I/O characteristics

● External dimensions (Units: mm)



## Looking for pricing, stock, or lifecycle information?

Click below to explore more details on WIN SOURCE:

-  [View BA5970FP-E2 on WIN SOURCE](#)
-  [Rohm Semiconductor Information](#)

## Optimize Your Supply Chain with WIN SOURCE Solutions

-  Global Sourcing Solution
-  Obsolete Management
-  Cost Control Management
-  Shortage Management
-  Alternative Solution
-  Excess Inventory Management