



**THE DATASHEET OF
CY62167G30-45ZXI**





Please note that Cypress is an Infineon Technologies Company.

The document following this cover page is marked as “Cypress” document as this is the company that originally developed the product. Please note that Infineon will continue to offer the product to new and existing customers as part of the Infineon product portfolio.

Continuity of document content

The fact that Infineon offers the following product as part of the Infineon product portfolio does not lead to any changes to this document. Future revisions will occur when appropriate, and any changes will be set out on the document history page.

Continuity of ordering part numbers

Infineon continues to support existing part numbers. Please continue to use the ordering part numbers listed in the datasheet for ordering.



CY62167G/CY62167GE MoBL

16-Mbit (1M words × 16-bit/ 2M words × 8-bit) Static RAM with Error-Correcting Code (ECC)

Features

- Ultra-low standby current
 - Typical standby current: 5.5 μ A
 - Maximum standby current: 16 μ A
- High speed: 45 ns/55 ns
- Embedded error-correcting code (ECC) for single-bit error correction
- Wide voltage range: 1.65 V to 2.2 V, and 4.5 V to 5.5 V
- 1.0-V data retention
- Transistor-transistor logic (TTL) compatible inputs and outputs
- Error indication (ERR) pin to indicate 1-bit error detection and correction
- 48-pin TSOP I package configurable as 1M × 16 or 2M × 8 SRAM
- Available in Pb-free 48-ball VFBGA and 48-pin TSOP I packages

Functional Description

CY62167G and CY62167GE are high-performance CMOS, low-power (MoBL[®]) SRAM devices with embedded ECC^[1]. Both devices are offered in single and dual chip enable options and in multiple pin configurations. The CY62167GE device includes an ERR pin that signals a single-bit error-detection and correction event during a read cycle.

To access devices with a single chip enable input, assert the chip enable (\overline{CE}) input LOW. To access dual chip enable devices, assert both chip enable inputs – \overline{CE}_1 as LOW and CE_2 as HIGH.

To perform data writes, assert the Write Enable (\overline{WE}) input LOW, and provide the data and address on the device data pins (I/O_0

through I/O_{15}) and address pins (A_0 through A_{19}) respectively. The Byte High Enable (BHE) and Byte Low Enable (BLE) inputs control byte writes and write data on the corresponding I/O lines to the memory location specified. BHE controls I/O_8 through I/O_{15} and BLE controls I/O_0 through I/O_7 .

To perform data reads, assert the Output Enable (\overline{OE}) input and provide the required address on the address lines. You can access read data on the I/O lines (I/O_0 through I/O_{15}). To perform byte accesses, assert the required byte enable signal (BHE or BLE) to read either the upper byte or the lower byte of data from the specified address location.

All I/O s (I/O_0 through I/O_{15}) are placed in a high-impedance state when the device is deselected (\overline{CE} HIGH for a single chip enable device and \overline{CE}_1 HIGH / CE_2 LOW for a dual chip enable device), or the control signals are de-asserted (\overline{OE} , BLE, BHE).

These devices have a unique Byte Power-down feature where, if both the Byte Enables (BHE and BLE) are disabled, the devices seamlessly switch to the standby mode irrespective of the state of the chip enables, thereby saving power.

On the CY62167GE devices, the detection and correction of a single-bit error in the accessed location is indicated by the assertion of the ERR output (ERR = High). See the [Truth Table – CY62167G/CY62167GE on page 16](#) for a complete description of read and write modes.

The CY62167G and CY62167GE devices are available in a Pb-free 48-pin TSOP I package and 48-ball VFBGA packages. The logic block diagrams are on page 2.

The device in the 48-pin TSOP I package can also be configured to function as a 2M words × 8-bit device. Refer to the Pin Configurations section for details.

For a complete list of related documentation, click [here](#).

Product Portfolio

Product	Features and Options (see the Pin Configurations section)	Range	V_{CC} Range (V)	Speed (ns)	Current Consumption			
					Operating I_{CC} , (mA)		Standby, I_{SB2} (μ A)	
					$f = f_{max}$			
					Typ ^[2]	Max	Typ ^[2]	Max
CY62167G(E)18	Single or Dual Chip Enables Optional ERR pin	Industrial	1.65 V–2.2 V	55	29	32	7	26
CY62167G(E)			4.5 V–5.5 V	45	29	36	5.5	16

Notes

1. This device does not support automatic write-back on error detection.
2. Typical values are included only for reference and are not guaranteed or tested. Typical values are measured at $V_{CC} = 1.8$ V (for V_{CC} range of 1.65 V–2.2 V), and $V_{CC} = 5$ V (for V_{CC} range of 4.5 V–5.5 V), $T_A = 25$ °C.

Logic Block Diagram – CY62167G

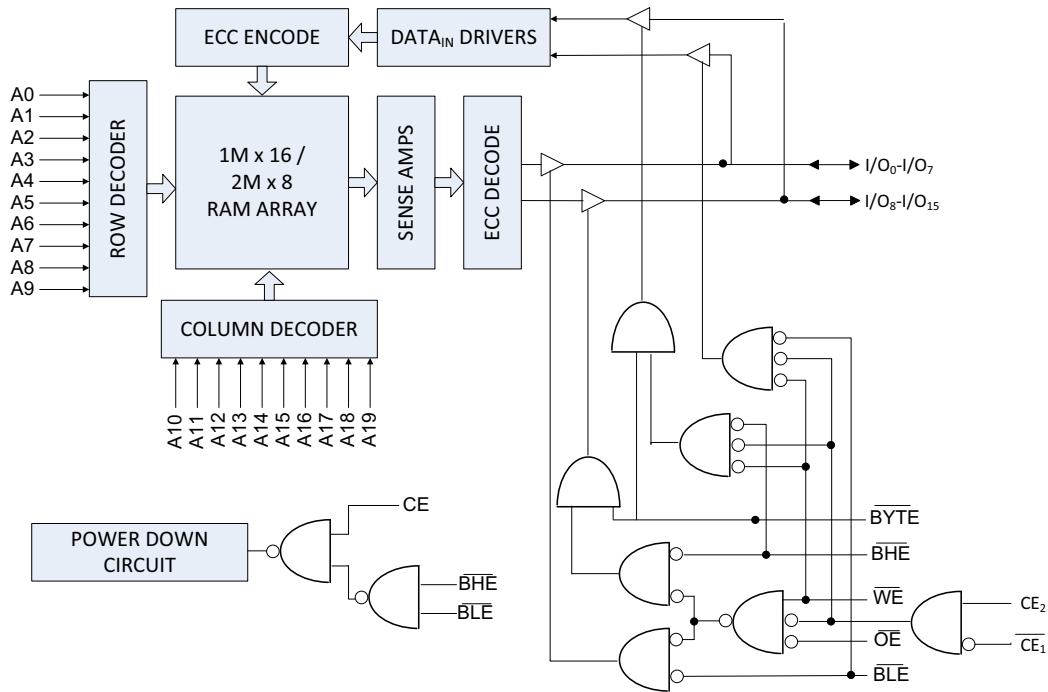

Logic Block Diagram – CY62167GE

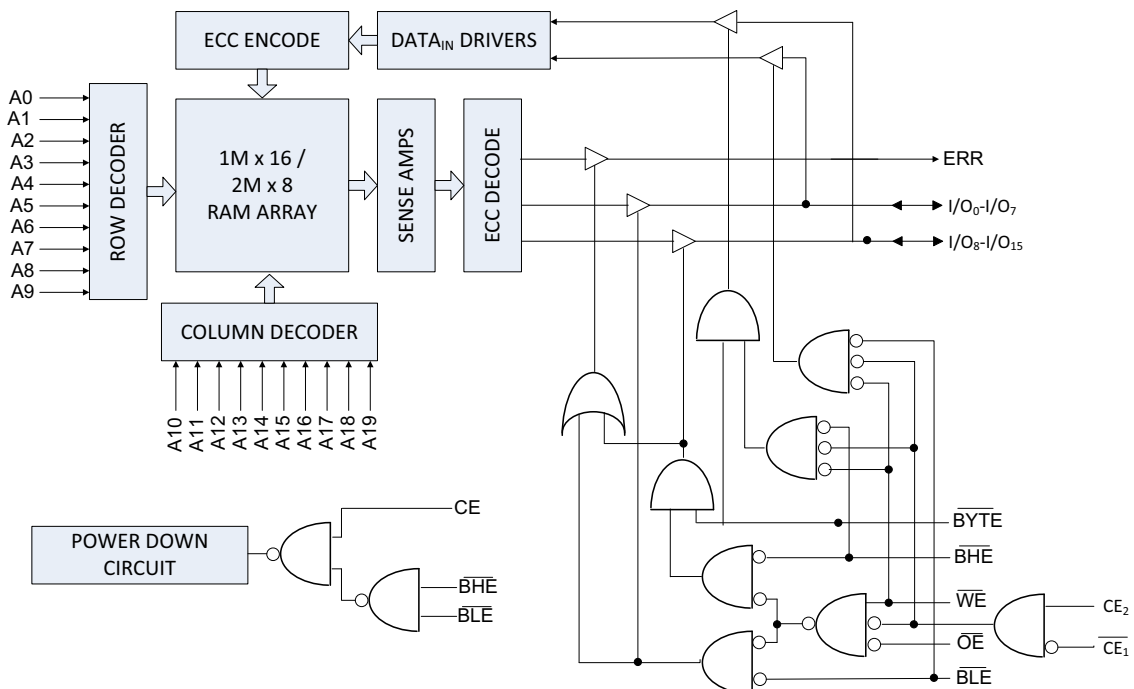

Contents

Pin Configuration – CY62167G	4	Ordering Information	17
Pin Configuration – CY62167GE	5	Ordering Code Definitions	17
Maximum Ratings	7	Package Diagrams	18
Operating Range	7	Acronyms	20
DC Electrical Characteristics	7	Document Conventions	20
Capacitance	9	Units of Measure	20
Thermal Resistance	9	Document History Page	21
AC Test Loads and Waveforms	9	Sales, Solutions, and Legal Information	23
Data Retention Characteristics	10	Worldwide Sales and Design Support	23
Data Retention Waveform	10	Products	23
Switching Characteristics	11	PSoC® Solutions	23
Switching Waveforms	12	Cypress Developer Community	23
Truth Table – CY62167G/CY62167GE	16	Technical Support	23
ERR Output – CY62167GE	16		

Pin Configuration – CY62167G

Figure 1. 48-ball VFBGA Pinout (Dual Chip Enable without ERR) – CY62167G [3]

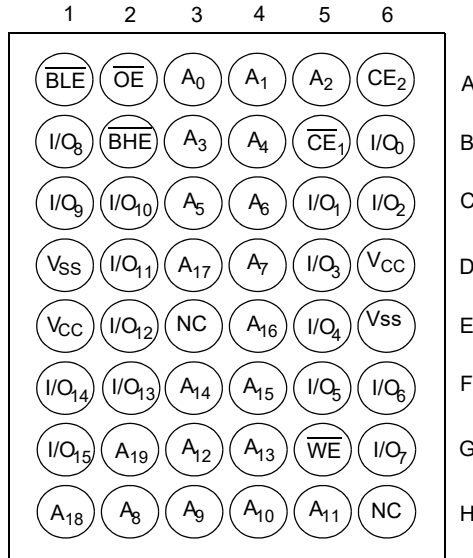
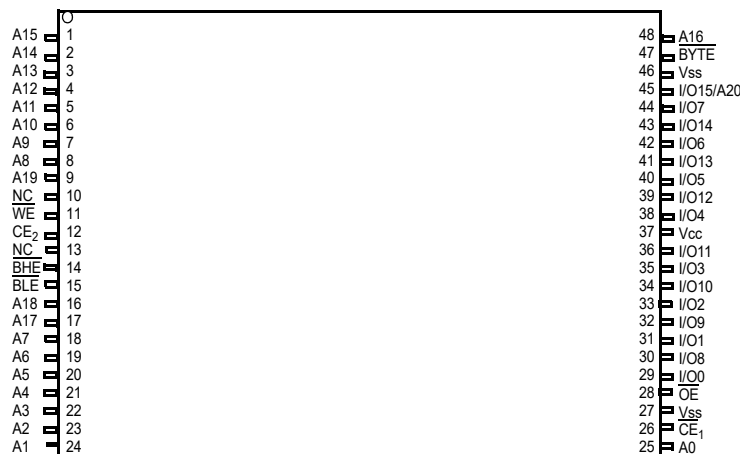

Figure 2. 48-pin TSOP I Pinout (Dual Chip Enable without ERR) – CY62167G [3, 4]



Notes

- 3. NC pins are not connected internally to the die and are typically used for address expansion to a higher-density device. Refer to the respective datasheets for pin configuration.
- 4. Tie the $\overline{\text{BYTE}}$ pin in the 48-pin TSOP I package to V_{CC} to use the device as a 1M × 16 SRAM. The 48-pin TSOP I package can also be used as a 2M × 8 SRAM by tying the $\overline{\text{BYTE}}$ signal to V_{SS}. In the 2M × 8 configuration, pin 45 is the extra address line A20, while $\overline{\text{BHE}}$, $\overline{\text{BLE}}$, and I/O₈ to I/O₁₄ pins are not used and can be left floating.

Pin Configuration – CY62167GE

Figure 3. 48-ball VFBGA Pinout (Single Chip Enable with ERR) – CY62167GE [5, 6]

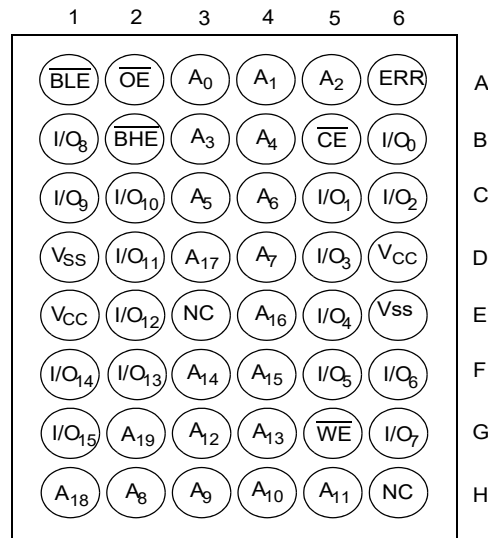
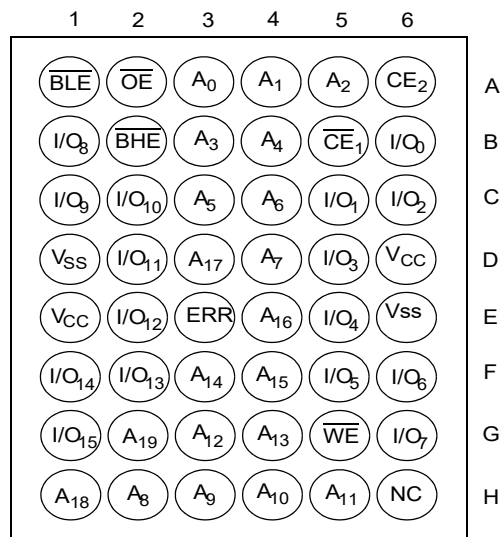

Figure 4. 48-ball VFBGA Pinout (Dual Chip Enable with ERR) – CY62167GE [5, 6]



Notes

- 5. NC pins are not connected internally to the die and are typically used for address expansion to a higher-density device. Refer to the respective datasheets for pin configuration.
- 6. ERR is an Output pin. If not used, this pin should be left floating.

Pin Configuration – CY62167GE (continued)

Figure 5. 48-pin TSOP I Pinout (Dual Chip Enable with ERR) – CY62167GE [7, 8]

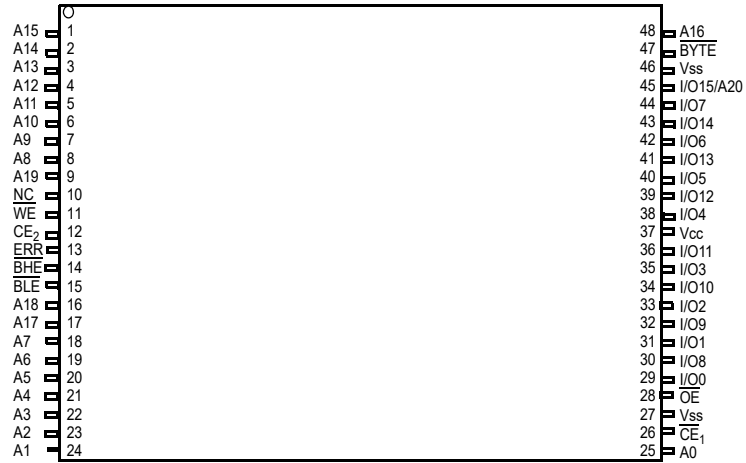

Notes

7. NC pins are not connected internally to the die and are typically used for address expansion to a higher-density device. Refer to the respective datasheets for pin configuration.
8. Tie the BYTE pin in the 48-pin TSOP I package to V_{CC} to use the device as a 1M × 16 SRAM. The 48-pin TSOP I package can also be used as a 2M × 8 SRAM by tying the BYTE signal to V_{SS}. In the 2M × 8 configuration, pin 45 is the extra address line A20, while the BHE, BLE, and I/O₈ to I/O₁₄ pins are not used and can be left floating.

Maximum Ratings

Exceeding maximum ratings may shorten the useful life of the device. User guidelines are not tested.

Storage temperature	-65 °C to + 150 °C
Ambient temperature with power applied	-55 °C to + 125 °C
Supply voltage to ground potential	-0.5 V to $V_{CC} + 0.5$ V
DC voltage applied to outputs in High Z state ^[9]	-0.5 V to $V_{CC} + 0.5$ V

DC input voltage ^[9]	-0.5 V to $V_{CC} + 0.5$ V
Output current into outputs (LOW)	20 mA
Static discharge voltage (MIL-STD-883, Method 3015)	>2001 V
Latch-up current	>140 mA

Operating Range

Grade	Ambient Temperature	V_{CC} ^[10]
Industrial	-40 °C to +85 °C	1.65 V to 2.2 V, 4.5 V to 5.5 V

DC Electrical Characteristics

Over the operating range of -40 °C to 85 °C

Parameter	Description	Test Conditions	45/55 ns			Unit	
			Min	Typ ^[11]	Max		
V_{OH}	Output HIGH voltage	1.65 V to 2.2 V	$V_{CC} = \text{Min}, I_{OH} = -0.1 \text{ mA}$	1.4	-	-	V
		4.5 V to 5.5 V	$V_{CC} = \text{Min}, I_{OH} = -1.0 \text{ mA}$	2.4	-	-	
		4.5 V to 5.5 V	$V_{CC} = \text{Min}, I_{OH} = -0.1 \text{ mA}$	$V_{CC} - 0.4$ ^[12]	-	-	
V_{OL}	Output LOW voltage	1.65 V to 2.2 V	$V_{CC} = \text{Min}, I_{OL} = 0.1 \text{ mA}$	-	-	0.2	
		4.5 V to 5.5 V	$V_{CC} = \text{Min}, I_{OL} = 2.1 \text{ mA}$	-	-	0.4	
V_{IH}	Input HIGH voltage ^[9]	1.65 V to 2.2 V	-	1.4	-	$V_{CC} + 0.2$	
		4.5 V to 5.5 V	-	2.2	-	$V_{CC} + 0.5$	
V_{IL}	Input LOW voltage ^[9]	1.65 V to 2.2 V	-	-0.2	-	0.4	
		4.5 V to 5.5 V	-	-0.5	-	0.8	
I_{IX}	Input leakage current	$GND \leq V_{IN} \leq V_{CC}$		-1.0	-	+1.0	μA
I_{OZ}	Output leakage current	$GND \leq V_{OUT} \leq V_{CC}$, Output disabled		-1.0	-	+1.0	
I_{CC}	V_{CC} operating supply current	$V_{CC} = \text{Max}, I_{OUT} = 0 \text{ mA}$, CMOS levels	$f = 22.22 \text{ MHz}$ (45 ns)	-	29.0	36.0	mA
			$f = 18.18 \text{ MHz}$ (55 ns)	-	29.0	32.0	
			$f = 1 \text{ MHz}$	-	7.0	9.0	

Notes

9. $V_{IL(\text{min})} = -2.0 \text{ V}$ and $V_{IH(\text{max})} = V_{CC} + 2 \text{ V}$ for pulse durations of less than 20 ns.
10. Full device AC operation assumes a 100- μs ramp time from 0 to $V_{CC}(\text{min})$ and 200- μs wait time after V_{CC} stabilizes to its operational value.
11. Indicates the value for the center of distribution at 3.0 V, 25 °C and not 100% tested.
12. This parameter is guaranteed by design and is not tested.

DC Electrical Characteristics (continued)

 Over the operating range of $-40\text{ }^{\circ}\text{C}$ to $85\text{ }^{\circ}\text{C}$

Parameter	Description	Test Conditions	45/55 ns			Unit
			Min	Typ ^[11]	Max	
I_{SB1} ^[13]	Automatic Power-down Current – CMOS Inputs; $V_{CC} = 4.5\text{ V to }5.5\text{ V}$	$\overline{CE}_1 \geq V_{CC} - 0.2\text{ V}$ or $CE_2 \leq 0.2\text{ V}$ or $(\overline{BHE}$ and $\overline{BLE}) \geq V_{CC} - 0.2\text{ V}$,	–	5.5	16.0	μA
	Automatic Power-down Current – CMOS Inputs $V_{CC} = 1.65\text{ V to }2.2\text{ V}$	$V_{IN} \geq V_{CC} - 0.2\text{ V}$, $V_{IN} \leq 0.2\text{ V}$, $f = f_{\text{max}}$ (address and data only), $f = 0$ (\overline{OE} , and \overline{WE}), $V_{CC} = V_{CC(\text{max})}$	–	7.0	26.0	
I_{SB2} ^[13]	Automatic Power-down Current – CMOS Inputs $V_{CC} = 4.5\text{ V to }5.5\text{ V}$	$\overline{CE}_1 \geq V_{CC} - 0.2\text{ V}$ or $CE_2 \leq 0.2\text{ V}$ or $(\overline{BHE}$ and $\overline{BLE}) \geq V_{CC} - 0.2\text{ V}$, $V_{IN} \geq V_{CC} - 0.2\text{ V}$ or $V_{IN} \leq 0.2\text{ V}$, $f = 0$, $V_{CC} = V_{CC(\text{max})}$	25 °C	–	5.5	6.5 ^[14]
			40 °C	–	6.3	8.0 ^[14]
			70 °C	–	8.4	12.0 ^[14]
			85 °C	–	12.0	16.0
	Automatic Power-down Current – CMOS Inputs $V_{CC} = 1.65\text{ V to }2.2\text{ V}$	$\overline{CE}_1 \geq V_{CC} - 0.2\text{ V}$ or $CE_2 \leq 0.2\text{ V}$ or $(\overline{BHE}$ and $\overline{BLE}) \geq V_{CC} - 0.2\text{ V}$, $V_{IN} \geq V_{CC} - 0.2\text{ V}$ or $V_{IN} \leq 0.2\text{ V}$, $f = 0$, $V_{CC} = V_{CC(\text{max})}$	–	7.0	26.0	

Notes

13. Chip enables \overline{CE}_1 and CE_2) and \overline{BYTE} must be tied to CMOS levels to meet the $I_{SB1}/I_{SB2}/I_{CCDR}$ spec. Other inputs can be left floating.
 14. The I_{SB2} maximum limits at 25 °C, 40 °C, and 70 °C are guaranteed by design and not 100% tested.

Capacitance

Parameter ^[15]	Description	Test Conditions	Max	Unit
C _{IN}	Input capacitance	T _A = 25 °C, f = 1 MHz, V _{CC} = V _{CC(typ)}	10.0	pF
C _{OUT}	Output capacitance		10.0	pF

Thermal Resistance

Parameter ^[15]	Description	Test Conditions	48-ball VFBGA	48-pin TSOP I	Unit
Θ _{JA}	Thermal resistance (junction to ambient)	Still air, soldered on a 3 × 4.5 inch, four-layer printed circuit board	31.50	57.99	°C/W
Θ _{JC}	Thermal resistance (junction to case)		15.75	13.42	°C/W

AC Test Loads and Waveforms

Figure 6. AC Test Loads and Waveforms

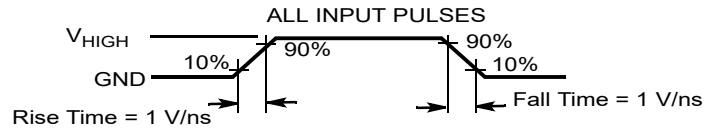
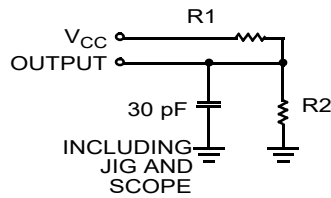

Equivalent to: THÉVENIN EQUIVALENT

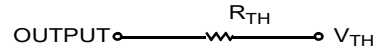

Parameters	1.8 V	2.5 V	3.0 V	5.0 V	Unit
R1	13500	16667	1103	1800	Ω
R2	10800	15385	1554	990	Ω
R _{TH}	6000	8000	645	639	Ω
V _{TH}	0.80	1.20	1.75	1.77	V
V _{HIGH}	1.8	2.5	3.0	5.0	V

Note

15. Tested initially and after any design or process changes that may affect these parameters.

Data Retention Characteristics

Over the Operating Range

Parameter	Description	Conditions	Min	Typ ^[16]	Max	Unit
V_{DR}	V_{CC} for data retention	–	1.0	–	–	V
I_{CCDR} ^[17, 18]	Data retention current	$1.2\text{ V} \leq V_{CC} \leq 2.2\text{ V}$, $\overline{CE}_1 \geq V_{CC} - 0.2\text{ V}$ or $CE_2 \leq 0.2\text{ V}$ or $(\overline{BHE}$ and $\overline{BLE}) \geq V_{CC} - 0.2\text{ V}$, $V_{IN} \geq V_{CC} - 0.2\text{ V}$ or $V_{IN} \leq 0.2\text{ V}$	–	7.0	26.0	μA
		$4.5\text{ V} \leq V_{CC} \leq 5.5\text{ V}$, $\overline{CE}_1 \geq V_{CC} - 0.2\text{ V}$ or $CE_2 \leq 0.2\text{ V}$ or $(\overline{BHE}$ and $\overline{BLE}) \geq V_{CC} - 0.2\text{ V}$, $V_{IN} \geq V_{CC} - 0.2\text{ V}$ or $V_{IN} \leq 0.2\text{ V}$	–	5.5	16.0	μA
t_{CDR} ^[19]	Chip deselect to data retention time	–	0.0	–	–	–
t_R ^[19, 20]	Operation recovery time	–	45/55	–	–	ns

Data Retention Waveform

Figure 7. Data Retention Waveform^[21]

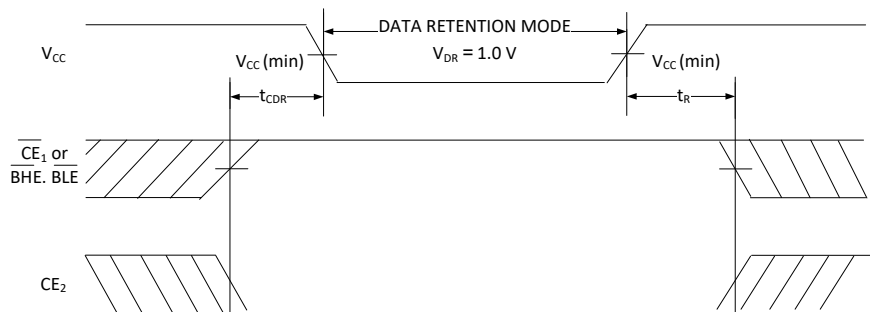

Notes

16. Indicates the value for the center of distribution at 3.0 V, 25 °C and not 100% tested.
17. Chip enables (\overline{CE}_1 and CE_2) and BYTE must be tied to CMOS levels to meet the $I_{SB1}/I_{SB2}/I_{CCDR}$ spec. Other inputs can be left floating.
18. I_{CCDR} is guaranteed only after the device is first powered up to $V_{CC(min)}$ and then brought down to V_{DR} .
19. These parameters are guaranteed by design and are not tested.
20. Full-device operation requires linear V_{CC} ramp from V_{DR} to $V_{CC(min)} \geq 100\ \mu\text{s}$ or stable at $V_{CC(min)} \geq 100\ \mu\text{s}$.
21. $\overline{BHE}, \overline{BLE}$ is the AND of both \overline{BHE} and \overline{BLE} . Deselect the chip by either disabling the chip enable signals or by disabling both \overline{BHE} and \overline{BLE} .

Switching Characteristics

Parameter ^[22]	Description	45 ns		55 ns		Unit
		Min	Max	Min	Max	
Read Cycle						
t_{RC}	Read cycle time	45.0	–	55.0	–	ns
t_{AA}	Address to data valid/Address to ERR valid	–	45.0	–	55.0	ns
t_{OHA}	Data hold from address change/ERR hold from address change	10.0	–	10.0	–	ns
t_{ACE}	\overline{CE}_1 LOW and CE_2 HIGH to data valid / \overline{CE} LOW to ERR valid	–	45.0	–	55.0	ns
t_{DOE}	\overline{OE} LOW to data valid/ \overline{OE} LOW to ERR valid	–	22.0	–	25.0	ns
t_{LZOE}	\overline{OE} LOW to Low Z ^[23, 24]	5.0	–	5.0	–	ns
t_{HZOE}	\overline{OE} HIGH to High Z ^[23, 24, 25]	–	18.0	–	18.0	ns
t_{LZCE}	\overline{CE}_1 LOW and CE_2 HIGH to Low Z ^[23, 24]	10.0	–	10.0	–	ns
t_{HZCE}	\overline{CE}_1 HIGH and CE_2 LOW to High Z ^[23, 24, 25]	–	18.0	–	18.0	ns
t_{PU}	\overline{CE}_1 LOW and CE_2 HIGH to power-up ^[26]	0.0	–	0.0	–	ns
t_{PD}	\overline{CE}_1 HIGH and CE_2 LOW to power-down ^[26]	–	45.0	–	55.0	ns
t_{DBE}	$\overline{BLE}/\overline{BHE}$ LOW to data valid	–	45.0	–	55.0	ns
t_{LZBE}	$\overline{BLE}/\overline{BHE}$ LOW to Low Z ^[23]	5.0	–	5.0	–	ns
t_{HZBE}	$\overline{BLE}/\overline{BHE}$ HIGH to High Z ^[23, 25]	–	18.0	–	18.0	ns
Write Cycle ^[27, 28]						
t_{WC}	Write cycle time	45.0	–	55.0	–	ns
t_{SCE}	\overline{CE}_1 LOW and CE_2 HIGH to write end	35.0	–	40.0	–	ns
t_{AW}	Address setup to write end	35.0	–	40.0	–	ns
t_{HA}	Address hold from write end	0	–	0	–	ns
t_{SA}	Address setup to write start	0	–	0	–	ns
t_{PWE}	\overline{WE} pulse width	35.0	–	40.0	–	ns
t_{BW}	$\overline{BLE}/\overline{BHE}$ LOW to write end	35.0	–	40.0	–	ns
t_{SD}	Data setup to write end	25.0	–	25.0	–	ns
t_{HD}	Data hold from write end	0.0	–	0.0	–	ns
t_{HZWE}	\overline{WE} LOW to High Z ^[23, 24, 25]	–	18.0	–	20.0	ns
t_{LZWE}	\overline{WE} HIGH to Low Z ^[23, 24]	10.0	–	10.0	–	ns

Notes

22. Test conditions assume signal transition time (rise/fall) of 3 ns or less, timing reference levels of 1.5 V (for $V_{CC} \geq 3$ V) and $V_{CC}/2$ (for $V_{CC} < 3$ V), and input pulse levels of 0 to 3 V (for $V_{CC} \geq 3$ V) and 0 to V_{CC} (for $V_{CC} < 3$ V). Test conditions for the read cycle use the output loading shown in Figure 6 on page 9, unless specified otherwise.
23. At any temperature and voltage condition, t_{HZCE} is less than t_{LZCE} , t_{HZBE} is less than t_{LZBE} , t_{HZOE} is less than t_{LZOE} , and t_{HZWE} is less than t_{LZWE} for any device.
24. Tested initially and after any design or process changes that may affect these parameters.
25. t_{HZOE} , t_{HZCE} , t_{HZBE} , and t_{HZWE} transitions are measured when the outputs enter a high-impedance state.
26. These parameters are guaranteed by design and are not tested.
27. The internal write time of the memory is defined by the overlap of $\overline{WE} = V_{IL}$, $\overline{CE}_1 = V_{IL}$, \overline{BHE} or \overline{BLE} or both = V_{IL} , and $CE_2 = V_{IH}$. All signals must be ACTIVE to initiate a write and any of these signals can terminate a write by going INACTIVE. The data input setup and hold timing must refer to the edge of the signal that terminates the write.
28. The minimum write cycle pulse width for Write Cycle No. 1 (\overline{WE} Controlled, \overline{OE} LOW) should be equal to the sum of t_{HZWE} and t_{SD} .

Switching Waveforms

Figure 8. Read Cycle No. 1 of CY62167G (Address Transition Controlled) [29, 30]

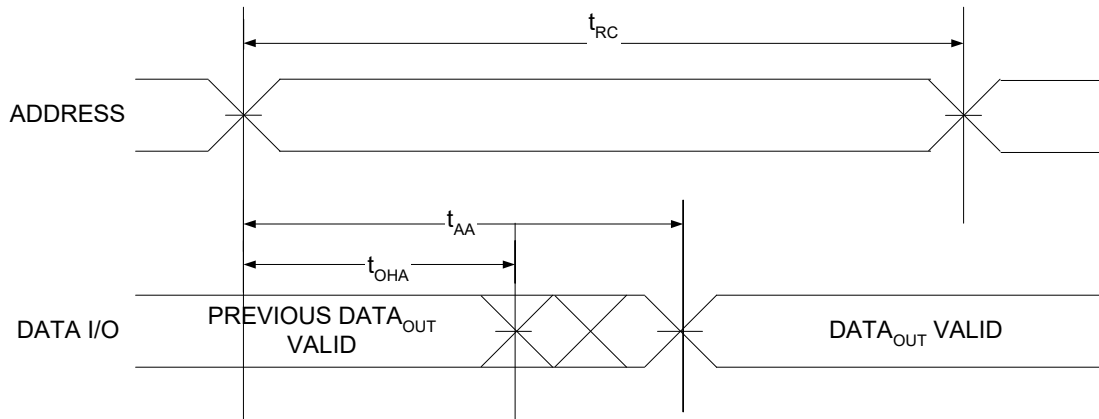
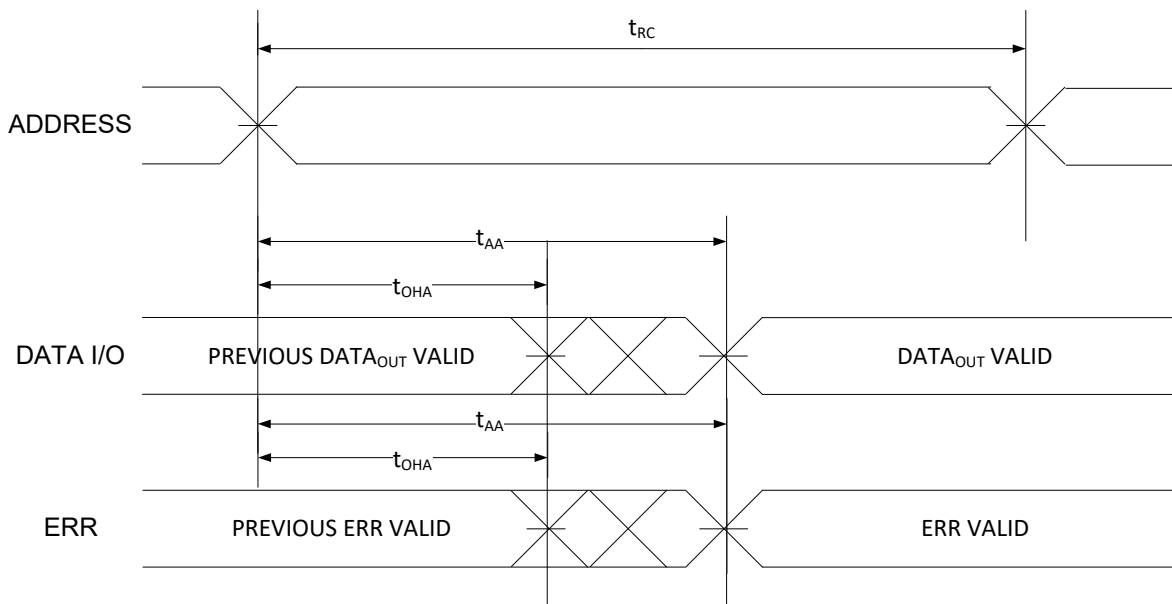

Figure 9. Read Cycle No. 1 of CY62167GE (Address Transition Controlled) [29, 30]



Notes

- 29. The device is continuously selected. $\overline{OE} = V_{IL}$, $\overline{CE} = V_{IL}$, \overline{BHE} or \overline{BLE} , or both = V_{IL} .
- 30. \overline{WE} is HIGH for read cycle.

Switching Waveforms (continued)

Figure 10. Read Cycle No. 2 (\overline{OE} Controlled) [31, 32, 33, 34]

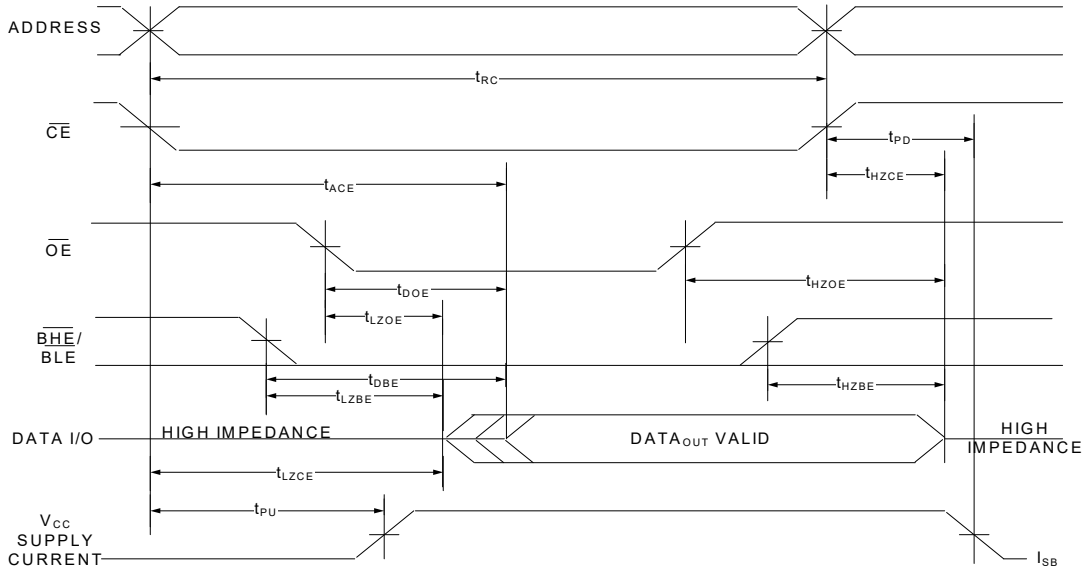
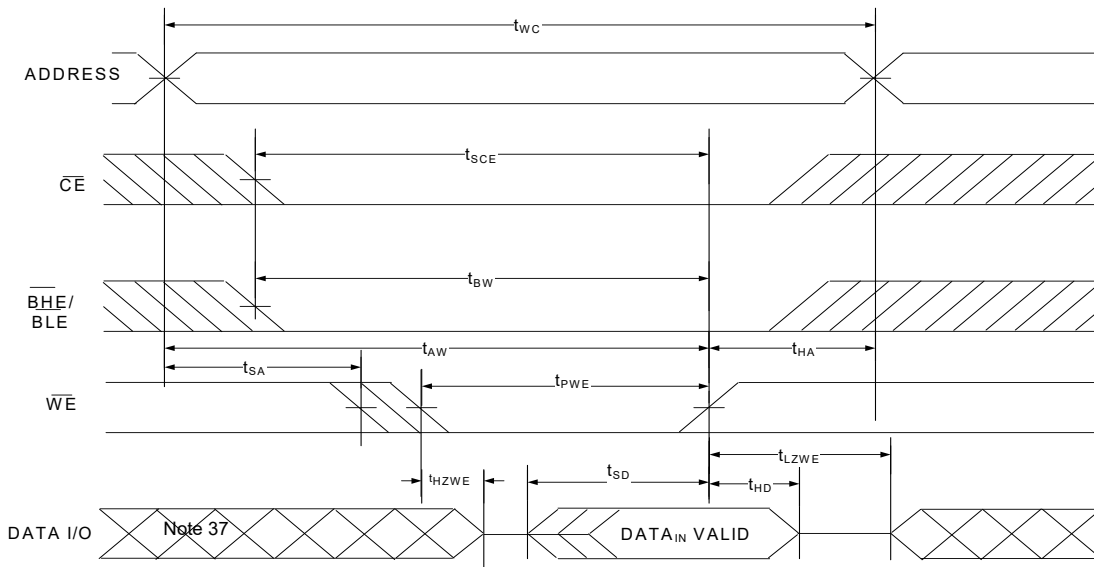

Figure 11. Write Cycle No. 1 (\overline{WE} Controlled, \overline{OE} LOW) [32, 34, 35, 36]



Notes

- 31. \overline{WE} is HIGH for read cycle.
- 32. For all dual chip enable devices, \overline{CE} is the logical combination of \overline{CE}_1 and CE_2 . When \overline{CE}_1 is LOW and CE_2 is HIGH, \overline{CE} is LOW; when \overline{CE}_1 is HIGH or CE_2 is LOW, \overline{CE} is HIGH.
- 33. Address valid prior to or coincident with \overline{CE} LOW transition.
- 34. Data I/O is in the high-impedance state if $\overline{CE} = V_{IH}$, or $\overline{OE} = V_{IH}$, or \overline{BHE} , and/or $\overline{BLE} = V_{IH}$.
- 35. The internal write time of the memory is defined by the overlap of $\overline{WE} = V_{IL}$, $\overline{CE}_1 = V_{IL}$, \overline{BHE} or \overline{BLE} , or both = V_{IL} , and $CE_2 = V_{IH}$. All signals must be ACTIVE to initiate a write and any of these signals can terminate a write by going INACTIVE. The data input setup and hold timing must refer to the edge of the signal that terminates the write.
- 36. The minimum write cycle pulse width should be equal to the sum of t_{HZWE} and t_{SD} .
- 37. During this period, the I/Os are in the output state. Do not apply input signals.

Switching Waveforms (continued)

Figure 12. Write Cycle No. 2 (\overline{CE} Controlled) [38, 39, 40]

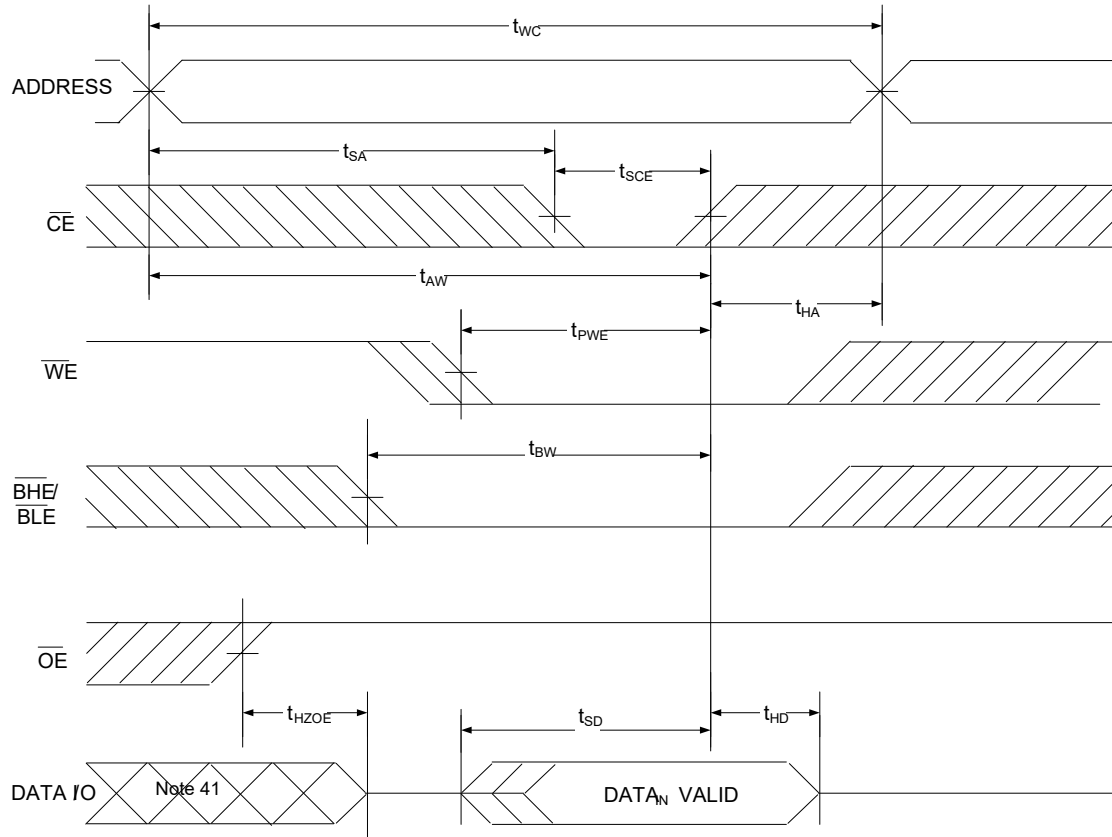

Notes

- 38. For all dual chip enable devices, \overline{CE} is the logical combination of \overline{CE}_1 and CE_2 . When \overline{CE}_1 is LOW and CE_2 is HIGH, \overline{CE} is LOW; when \overline{CE}_1 is HIGH or CE_2 is LOW, \overline{CE} is HIGH.
- 39. The internal write time of the memory is defined by the overlap of $\overline{WE} = V_{IL}$, $\overline{CE}_1 = V_{IL}$, \overline{BHE} or \overline{BLE} or both = V_{IL} , and $CE_2 = V_{IH}$. All signals must be ACTIVE to initiate a write and any of these signals can terminate a write by going INACTIVE. The data input setup and hold timing must refer to the edge of the signal that terminates the write.
- 40. Data I/O is in the high-impedance state if $\overline{CE} = V_{IH}$, or $\overline{OE} = V_{IH}$, or \overline{BHE} , and/or $\overline{BLE} = V_{IH}$.
- 41. During this period, the I/Os are in output state. Do not apply input signals.

Switching Waveforms (continued)

Figure 13. Write Cycle No. 4 ($\overline{\text{BHE}}/\overline{\text{BLE}}$ Controlled, $\overline{\text{OE}}$ LOW) [42, 43, 44]

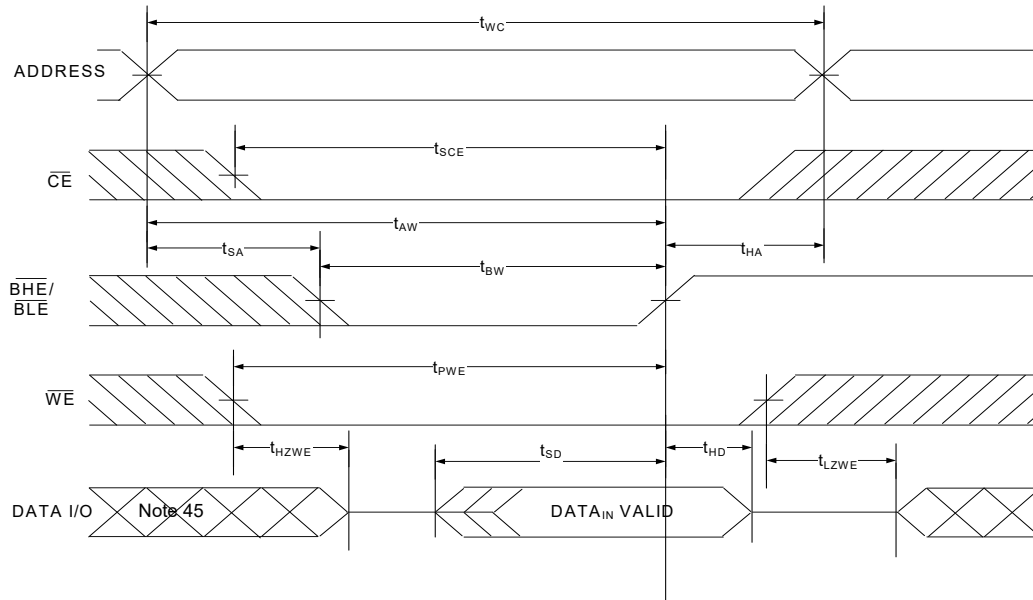
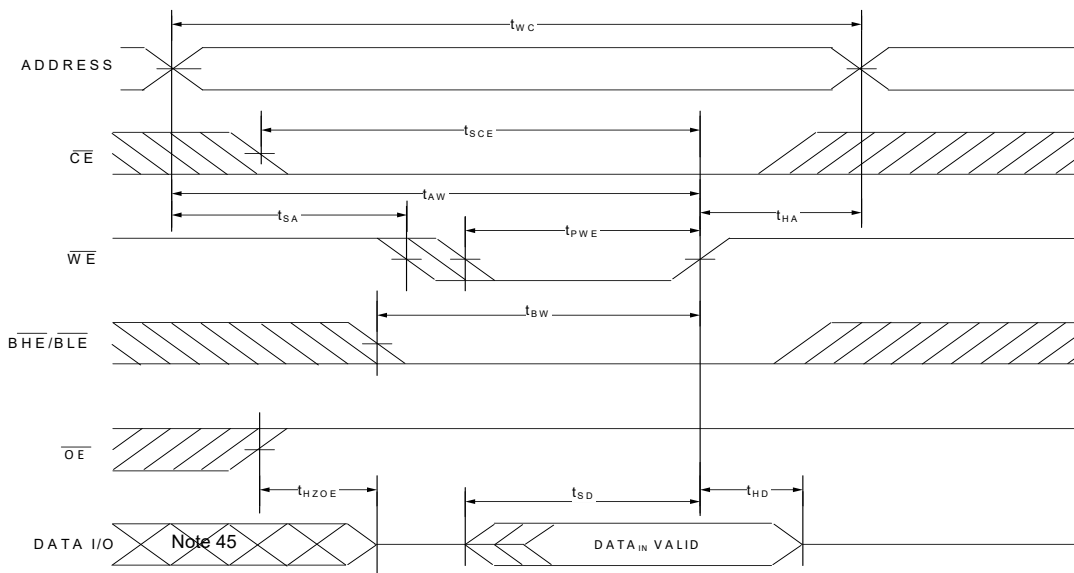

Figure 14. Write Cycle No. 5 ($\overline{\text{WE}}$ Controlled) [42, 43, 44]



Notes

- 42. For all dual chip enable devices, $\overline{\text{CE}}$ is the logical combination of $\overline{\text{CE}}_1$ and CE_2 . When $\overline{\text{CE}}_1$ is LOW and CE_2 is HIGH, $\overline{\text{CE}}$ is LOW; when $\overline{\text{CE}}_1$ is HIGH or CE_2 is LOW, $\overline{\text{CE}}$ is HIGH.
- 43. The internal write time of the memory is defined by the overlap of $\overline{\text{WE}} = V_{\text{IL}}$, $\overline{\text{CE}}_1 = V_{\text{IL}}$, $\overline{\text{BHE}}$ or $\overline{\text{BLE}}$ or both = V_{IL} , and $\text{CE}_2 = V_{\text{IH}}$. All signals must be ACTIVE to initiate a write and any of these signals can terminate a write by going INACTIVE. The data input setup and hold timing must refer to the edge of the signal that terminates the write.
- 44. Data I/O is in the high-impedance state if $\overline{\text{CE}} = V_{\text{IH}}$, or $\overline{\text{OE}} = V_{\text{IH}}$, or $\overline{\text{BHE}}$, and/or $\overline{\text{BLE}} = V_{\text{IH}}$.
- 45. During this period, the I/Os are in output state. Do not apply input signals.

Truth Table – CY62167G/CY62167GE

BYTE ^[46]	\overline{CE}_1	CE_2	\overline{WE}	\overline{OE}	\overline{BHE}	\overline{BLE}	Inputs/Outputs	Mode	Power	Configuration
X ^[47]	H	X ^[47]	X	X	X	X	High-Z	Deselect/Power-down	Standby (I_{SB})	2M × 8/1M × 16
X	X ^[47]	L	X	X	X	X	High-Z	Deselect/Power-down	Standby (I_{SB})	2M × 8/1M × 16
X	X ^[47]	X ^[47]	X	X	H	H	High-Z	Deselect/Power-down	Standby (I_{SB})	1M × 16
H	L	H	H	L	L	L	Data Out (I/O ₀ –I/O ₁₅)	Read	Active (I_{CC})	1M × 16
H	L	H	H	L	H	L	Data Out (I/O ₀ –I/O ₇); High-Z (I/O ₈ –I/O ₁₅)	Read	Active (I_{CC})	1M × 16
H	L	H	H	L	L	H	High Z (I/O ₀ –I/O ₇); Data Out (I/O ₈ –I/O ₁₅)	Read	Active (I_{CC})	1M × 16
H	L	H	H	H	L	H	High-Z	Output disabled	Active (I_{CC})	1M × 16
H	L	H	H	H	H	L	High-Z	Output disabled	Active (I_{CC})	1M × 16
H	L	H	H	H	L	L	High-Z	Output disabled	Active (I_{CC})	1M × 16
H	L	H	L	X	L	L	Data In (I/O ₀ –I/O ₁₅)	Write	Active (I_{CC})	1M × 16
H	L	H	L	X	H	L	Data In (I/O ₀ –I/O ₇); High-Z (I/O ₈ –I/O ₁₅)	Write	Active (I_{CC})	1M × 16
H	L	H	L	X	L	H	High-Z (I/O ₀ –I/O ₇); Data In (I/O ₈ –I/O ₁₅)	Write	Active (I_{CC})	1M × 16
L	L	H	H	L	X	X	Data Out (I/O ₀ –I/O ₇)	Read	Active (I_{CC})	2M × 8
L	L	H	H	H	X	X	High-Z	Output disabled	Active (I_{CC})	2M × 8
L	L	H	L	X	X	X	Data In (I/O ₀ –I/O ₇)	Write	Active (I_{CC})	2M × 8

ERR Output – CY62167GE

Output ^[48]	Mode
0	Read operation, no single-bit error in the stored data.
1	Read operation, single-bit error detected and corrected.
High-Z	Device deselected / outputs disabled / Write operation

Notes

46. This pin is available only in the 48-pin TSOP I package. Tie the \overline{BYTE} to V_{CC} to configure the device in the 1M × 16 option. The 48-pin TSOP I package can also be used as a 2M × 8 SRAM by tying the \overline{BYTE} signal to V_{SS} .

47. The 'X' (Don't care) state for the chip enables refer to the logic state (either HIGH or LOW). Intermediate voltage levels on these pins is not permitted.

48. ERR is an Output pin. If not used, this pin should be left floating.

Ordering Information

Speed (ns)	Voltage Range	Ordering Code	Package Diagram	Package Type (all Pb-free)	Key Features / Differentiators	ERR Pin / Ball	Operating Range
45	4.5 V–5.5 V	CY62167G-45BVXI	51-85150	48-ball VFBGA	Dual Chip Enable	No	Industrial
		CY62167G-45BVXIT					
		CY62167G-45ZXI	51-85183	48-pin TSOP I	Dual Chip Enable	No	
		CY62167G-45ZXIT					
		CY62167GE-45ZXI				Yes	
		CY62167GE-45ZXIT					
55	1.65 V–2.2 V	CY62167GE18-55BVXI	51-85150	48-ball VFBGA	Dual Chip Enable	Yes	
		CY62167GE18-55BVXIT				No	
		CY62167G18-55BVXI	51-85183	48-pin TSOP I	No		
		CY62167G18-55BVXIT					
		CY62167G18-55ZXI					
		CY62167G18-55ZXIT					

Ordering Code Definitions

CY 621 6 7 G E XX - XX XX X X X X

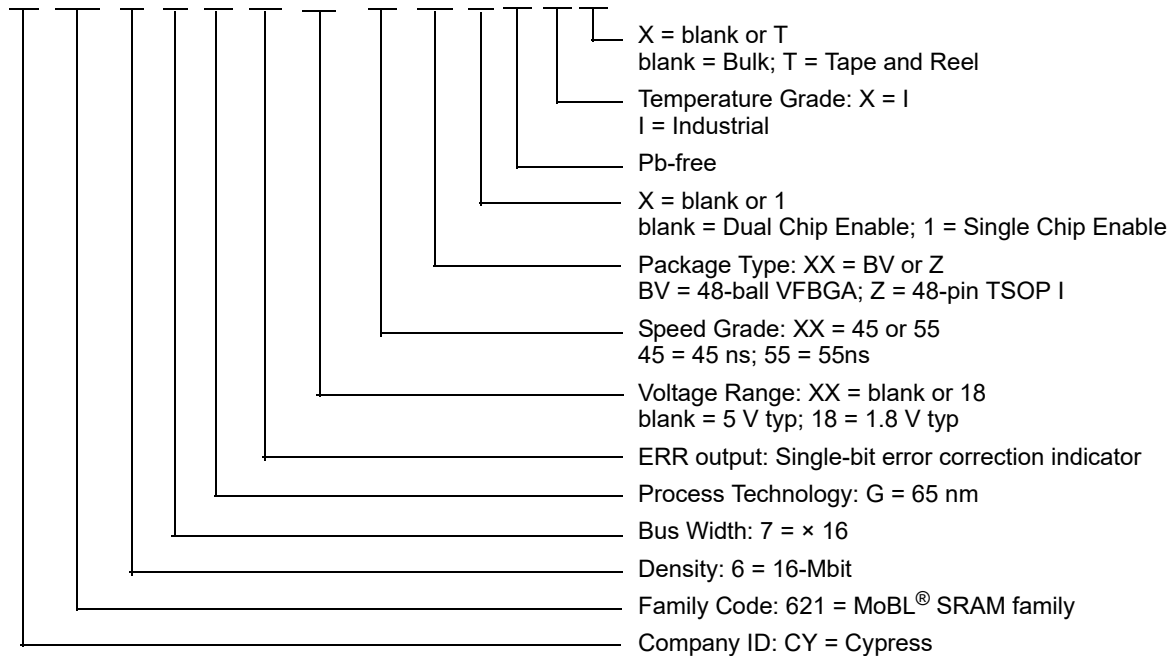

Package Diagrams

Figure 15. 48-ball VFBGA (6 × 8 × 1.0 mm) Package Outline, 51-85150

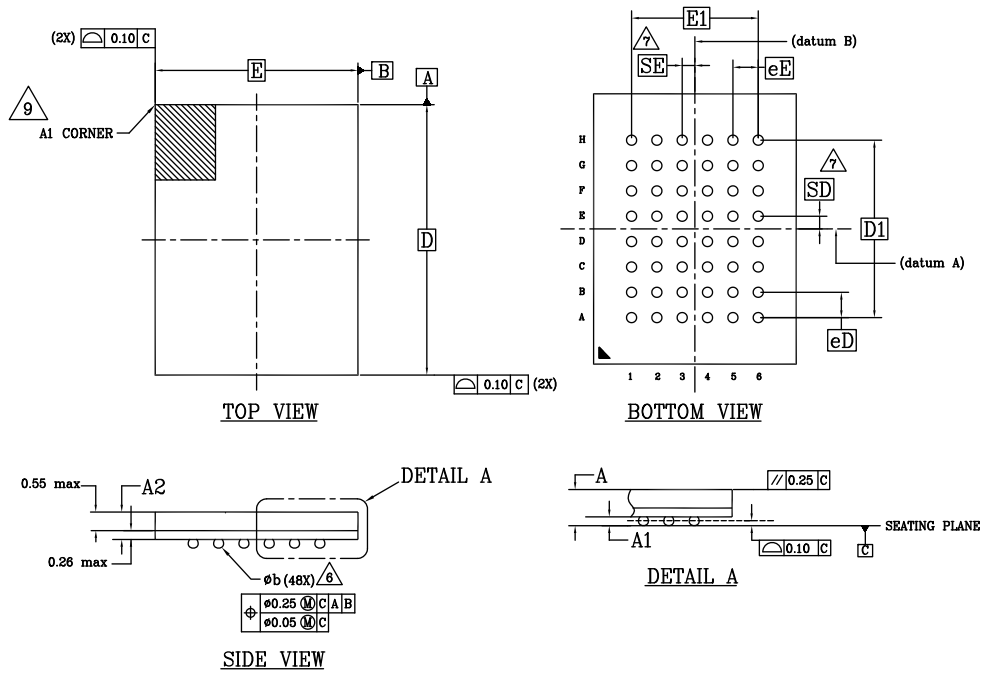

SYMBOL	DIMENSIONS		
	MIN.	NOM.	MAX.
A	-	-	1.00
A1	0.16	-	-
A2	-	-	0.81
D	8.00 BSC		
E	6.00 BSC		
D1	5.25 BSC		
E1	3.75 BSC		
MD	8		
ME	6		
n	48		
∅ b	0.25	0.30	0.35
eE	0.75 BSC		
eD	0.75 BSC		
SD	0.375 BSC		
SE	0.375 BSC		

NOTES:

- DIMENSIONING AND TOLERANCING METHODS PER ASME Y14.5M-2009.
- ALL DIMENSIONS ARE IN MILLIMETERS.
- BALL POSITION DESIGNATION PER JEP95, SECTION 3, SPP-020.
- ☐ REPRESENTS THE SOLDER BALL GRID PITCH.
- SYMBOL "MD" IS THE BALL MATRIX SIZE IN THE "D" DIRECTION. SYMBOL "ME" IS THE BALL MATRIX SIZE IN THE "E" DIRECTION. n IS THE NUMBER OF POPULATED SOLDER BALL POSITIONS FOR MATRIX SIZE MD X ME.
- ∅ b DIMENSION "b" IS MEASURED AT THE MAXIMUM BALL DIAMETER IN A PLANE PARALLEL TO DATUM C.
- *SD* AND *SE* ARE MEASURED WITH RESPECT TO DATUMS A AND B AND DEFINE THE POSITION OF THE CENTER SOLDER BALL IN THE OUTER ROW. WHEN THERE IS AN ODD NUMBER OF SOLDER BALLS IN THE OUTER ROW *SD* OR *SE* = 0. WHEN THERE IS AN EVEN NUMBER OF SOLDER BALLS IN THE OUTER ROW, *SD* = eD/2 AND *SE* = eE/2.
- ** INDICATES THE THEORETICAL CENTER OF DEPOPULATED BALLS.
- A1 CORNER TO BE IDENTIFIED BY CHAMFER, LASER OR INK MARK METALIZED MARK, INDENTATION OR OTHER MEANS.

51-85150 *I

Package Diagrams (continued)

Figure 16. 48-pin TSOP I (18.4 × 12 × 1.2 mm) Package Outline, 51-85183

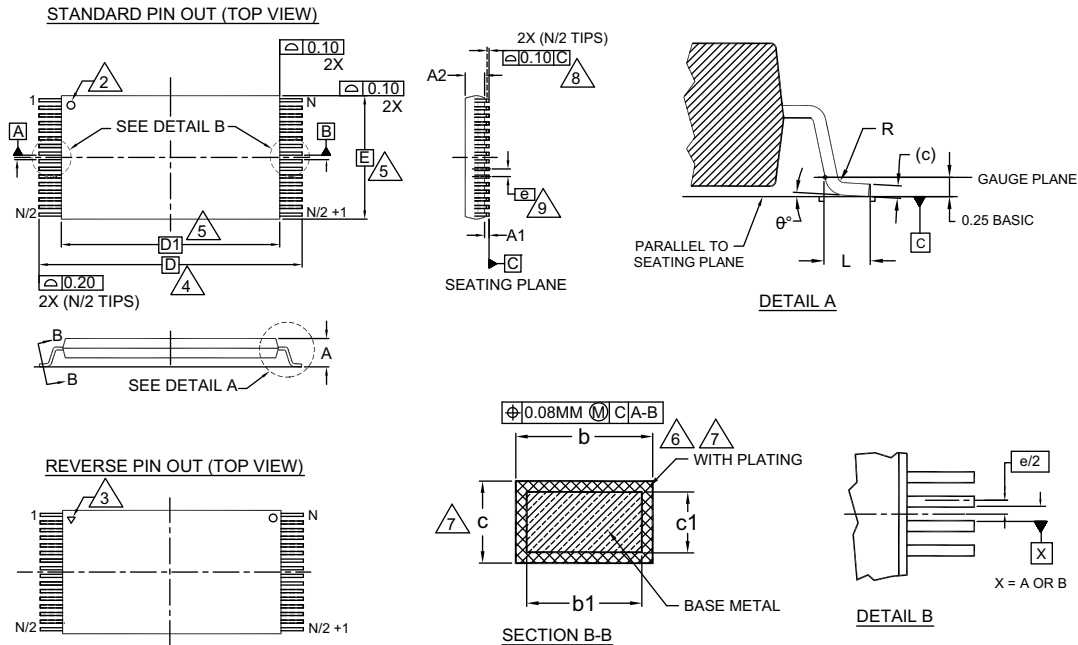

SYMBOL	DIMENSIONS		
	MIN.	NOM.	MAX.
A	—	—	1.20
A1	0.05	—	0.15
A2	0.95	1.00	1.05
b1	0.17	0.20	0.23
b	0.17	0.22	0.27
c1	0.10	—	0.16
c	0.10	—	0.21
D	20.00 BASIC		
D1	18.40 BASIC		
E	12.00 BASIC		
e	0.50 BASIC		
L	0.50	0.60	0.70
theta	0°	—	8
R	0.08	—	0.20
N	48		

NOTES:

1. DIMENSIONS ARE IN MILLIMETERS (mm).
2. PIN 1 IDENTIFIER FOR STANDARD PIN OUT (DIE UP).
3. PIN 1 IDENTIFIER FOR REVERSE PIN OUT (DIE DOWN); INK OR LASER MARK.
4. TO BE DETERMINED AT THE SEATING PLANE [C-]. THE SEATING PLANE IS DEFINED AS THE PLANE OF CONTACT THAT IS MADE WHEN THE PACKAGE LEADS ARE ALLOWED TO REST FREELY ON A FLAT HORIZONTAL SURFACE.
5. DIMENSIONS D1 AND E DO NOT INCLUDE MOLD PROTRUSION. ALLOWABLE MOLD PROTRUSION ON E IS 0.15mm PER SIDE AND ON D1 IS 0.25mm PER SIDE.
6. DIMENSION b DOES NOT INCLUDE DAMBAR PROTRUSION. ALLOWABLE DAMBAR PROTRUSION SHALL BE 0.08mm TOTAL IN EXCESS OF b DIMENSION AT MAX. MATERIAL CONDITION. DAMBAR CANNOT BE LOCATED ON LOWER RADIUS OR THE FOOT. MINIMUM SPACE BETWEEN PROTRUSION AND AN ADJACENT LEAD TO BE 0.07mm .
7. THESE DIMENSIONS APPLY TO THE FLAT SECTION OF THE LEAD BETWEEN 0.10mm AND 0.25mm FROM THE LEAD TIP.
8. LEAD COPLANARITY SHALL BE WITHIN 0.10mm AS MEASURED FROM THE SEATING PLANE.
9. DIMENSION "e" IS MEASURED AT THE CENTERLINE OF THE LEADS.
10. JEDEC SPECIFICATION NO. REF: MO-142(D)DD.

51-85183 *F

Acronyms

Acronym	Description
BHE	Byte High Enable
BLE	Byte Low Enable
CE	Chip Enable
CMOS	Complementary metal oxide semiconductor
I/O	Input/output
OE	Output Enable
SRAM	Static random access memory
TSOP	Thin small outline package
VFBGA	Very fine-pitch ball grid array
WE	Write Enable

Document Conventions

Units of Measure

Symbol	Unit of Measure
°C	degree Celsius
MHz	megahertz
μA	microampere
μs	microsecond
mA	milliampere
mm	millimeter
ns	nanosecond
Ω	ohm
%	percent
pF	picofarad
V	volt
W	watt

Document History Page

Document Title: CY62167G/CY62167GE MoBL, 16-Mbit (1M words × 16-bit/2M words × 8-bit) Static RAM with Error-Correcting Code (ECC) Document Number: 001-81537			
Rev.	ECN No.	Submission Date	Description of Change
*M	4791835	06/15/2015	Changed status from Preliminary to Final. Completing Sunset Review.
*N	5027105	11/25/2015	Updated DC Electrical Characteristics : Changed minimum value of V_{OH} parameter from 2.2 V to 2.4 V corresponding to Operating Range “2.7 V to 3.6 V” and Test Condition “ $V_{CC} = \text{Min}$, $I_{OH} = -1.0 \text{ mA}$ ”.
*O	5439177	09/16/2016	Updated DC Electrical Characteristics : Changed minimum value of V_{IH} parameter from 2.0 V to 1.8 V corresponding to Operating Range “2.2 V to 2.7 V”. Updated Note 9 (Replaced 2 ns with 20 ns). Updated Ordering Information : Updated part numbers. Updated Ordering Code Definitions . Updated to new template.
*P	5751153	05/26/2017	Updated Package Diagrams : spec 51-85183 – Changed revision from *D to *F. Updated to new template. Completing Sunset Review.
*Q	6607623	09/23/2019	Updated Product Portfolio : Added Note “The 3V Typical V_{CC} device is offered with improved I_{CC} , I_{SB1} and I_{SB2} specifications compared to the current revision with same marketing part number. The new device will be in production from WW1952. For more information, please contact Cypress Sales representative.” and referred the same note in CY62167G(E)30. Added Note “For next version of this 3V Typical V_{CC} device, kindly refer here . Further details about improvement and comparison between current and new versions can be found in the PCN193805 .” and referred the same note in CY62167G(E)30. Updated DC Electrical Characteristics : Added Note “The 3V Typical V_{CC} device is offered with improved I_{CC} , I_{SB1} and I_{SB2} specifications compared to the current revision with same marketing part number. The new device will be in production from WW1952. For more information, please contact Cypress Sales representative.” and referred the same note in “2.2 V to 2.7 V”, “2.7 V to 3.6 V” in “Description” column corresponding to V_{OH} , V_{OL} , V_{IH} , V_{IL} parameters. Added Note “For next version of this 3V Typical V_{CC} device, kindly refer here . Further details about improvement and comparison between current and new versions can be found in the PCN193805 .” and referred the same note in “2.2 V to 2.7 V”, “2.7 V to 3.6 V” in “Description” column corresponding to V_{OH} , V_{OL} , V_{IH} , V_{IL} parameters. Added Note “The 3V Typical V_{CC} device is offered with improved I_{CC} , I_{SB1} and I_{SB2} specifications compared to the current revision with same marketing part number. The new device will be in production from WW1952. For more information, please contact Cypress Sales representative.” and referred the same note in “ $V_{CC} = 2.2 \text{ V}$ to 3.6 V” in “Description” column corresponding to I_{SB1} , I_{SB2} parameters. Added Note “For next version of this 3V Typical V_{CC} device, kindly refer here . Further details about improvement and comparison between current and new versions can be found in the PCN193805 .” and referred the same note in “ $V_{CC} = 2.2 \text{ V}$ to 3.6 V” in “Description” column corresponding to I_{SB1} , I_{SB2} parameters.

Document History Page (continued)

Document Title: CY62167G/CY62167GE MoBL, 16-Mbit (1M words × 16-bit/2M words × 8-bit) Static RAM with Error-Correcting Code (ECC) Document Number: 001-81537			
Rev.	ECN No.	Submission Date	Description of Change
*Q (cont.)	6607623	09/23/2019	<p>Updated Data Retention Characteristics:</p> <p>Added Note "The 3V Typical V_{CC} device is offered with improved I_{CC}, I_{SB1} and I_{SB2} specifications compared to the current revision with same marketing part number. The new device will be in production from WW1952. For more information, please contact Cypress Sales representative." and referred the same note in "$2.2\text{ V} < V_{CC} \leq 3.6\text{ V}$" in "Conditions" column corresponding to I_{CCDR} parameter.</p> <p>Added Note "For next version of this 3V Typical V_{CC} device, kindly refer here. Further details about improvement and comparison between current and new versions can be found in the PCN193805." and referred the same note in "$2.2\text{ V} < V_{CC} \leq 3.6\text{ V}$" in "Conditions" column corresponding to I_{CCDR} parameter.</p> <p>Updated Package Diagrams: spec 51-85150 – Changed revision from *H to *I. Updated to new template. Completing Sunset Review.</p>
*R	6801217	02/07/2020	<p>Removed "2.2 V to 3.6 V" voltage range related information in all instances across the document.</p> <p>Updated Ordering Information: Updated part numbers. Updated to new template.</p>

Sales, Solutions, and Legal Information

Worldwide Sales and Design Support

Cypress maintains a worldwide network of offices, solution centers, manufacturer's representatives, and distributors. To find the office closest to you, visit us at [Cypress Locations](#).

Products

Arm [®] Cortex [®] Microcontrollers	cypress.com/arm
Automotive	cypress.com/automotive
Clocks & Buffers	cypress.com/clocks
Interface	cypress.com/interface
Internet of Things	cypress.com/iot
Memory	cypress.com/memory
Microcontrollers	cypress.com/mcu
PSoC	cypress.com/psoc
Power Management ICs	cypress.com/pmic
Touch Sensing	cypress.com/touch
USB Controllers	cypress.com/usb
Wireless Connectivity	cypress.com/wireless

PSoC[®] Solutions

[PSoC 1](#) | [PSoC 3](#) | [PSoC 4](#) | [PSoC 5LP](#) | [PSoC 6 MCU](#)

Cypress Developer Community

[Community](#) | [Code Examples](#) | [Projects](#) | [Video](#) | [Blogs](#) | [Training](#) | [Components](#)

Technical Support

cypress.com/support

© Cypress Semiconductor Corporation, 2012–2020. This document is the property of Cypress Semiconductor Corporation and its subsidiaries ("Cypress"). This document, including any software or firmware included or referenced in this document ("Software"), is owned by Cypress under the intellectual property laws and treaties of the United States and other countries worldwide. Cypress reserves all rights under such laws and treaties and does not, except as specifically stated in this paragraph, grant any license under its patents, copyrights, trademarks, or other intellectual property rights. If the Software is not accompanied by a license agreement and you do not otherwise have a written agreement with Cypress governing the use of the Software, then Cypress hereby grants you a personal, non-exclusive, nontransferable license (without the right to sublicense) (1) under its copyright rights in the Software (a) for Software provided in source code form, to modify and reproduce the Software solely for use with Cypress hardware products, only internally within your organization, and (b) to distribute the Software in binary code form externally to end users (either directly or indirectly through resellers and distributors), solely for use on Cypress hardware product units, and (2) under those claims of Cypress's patents that are infringed by the Software (as provided by Cypress, unmodified) to make, use, distribute, and import the Software solely for use with Cypress hardware products. Any other use, reproduction, modification, translation, or compilation of the Software is prohibited.

TO THE EXTENT PERMITTED BY APPLICABLE LAW, CYPRESS MAKES NO WARRANTY OF ANY KIND, EXPRESS OR IMPLIED, WITH REGARD TO THIS DOCUMENT OR ANY SOFTWARE OR ACCOMPANYING HARDWARE, INCLUDING, BUT NOT LIMITED TO, THE IMPLIED WARRANTIES OF MERCHANTABILITY AND FITNESS FOR A PARTICULAR PURPOSE. No computing device can be absolutely secure. Therefore, despite security measures implemented in Cypress hardware or software products, Cypress shall have no liability arising out of any security breach, such as unauthorized access to or use of a Cypress product. CYPRESS DOES NOT REPRESENT, WARRANT, OR GUARANTEE THAT CYPRESS PRODUCTS, OR SYSTEMS CREATED USING CYPRESS PRODUCTS, WILL BE FREE FROM CORRUPTION, ATTACK, VIRUSES, INTERFERENCE, HACKING, DATA LOSS OR THEFT, OR OTHER SECURITY INTRUSION (collectively, "Security Breach"). Cypress disclaims any liability relating to any Security Breach, and you shall and hereby do release Cypress from any claim, damage, or other liability arising from any Security Breach. In addition, the products described in these materials may contain design defects or errors known as errata which may cause the product to deviate from published specifications. To the extent permitted by applicable law, Cypress reserves the right to make changes to this document without further notice. Cypress does not assume any liability arising out of the application or use of any product or circuit described in this document. Any information provided in this document, including any sample design information or programming code, is provided only for reference purposes. It is the responsibility of the user of this document to properly design, program, and test the functionality and safety of any application made of this information and any resulting product. "High-Risk Device" means any device or system whose failure could cause personal injury, death, or property damage. Examples of High-Risk Devices are weapons, nuclear installations, surgical implants, and other medical devices. "Critical Component" means any component of a High-Risk Device whose failure to perform can be reasonably expected to cause, directly or indirectly, the failure of the High-Risk Device, or to affect its safety or effectiveness. Cypress is not liable, in whole or in part, and you shall and hereby do release Cypress from any claim, damage, or other liability arising from any use of a Cypress product as a Critical Component in a High-Risk Device. You shall indemnify and hold Cypress, its directors, officers, employees, agents, affiliates, distributors, and assigns harmless from and against all claims, costs, damages, and expenses, arising out of any claim, including claims for product liability, personal injury or death, or property damage arising from any use of a Cypress product as a Critical Component in a High-Risk Device. Cypress products are not intended or authorized for use as a Critical Component in any High-Risk Device except to the limited extent that (i) Cypress's published data sheet for the product explicitly states Cypress has qualified the product for use in a specific High-Risk Device, or (ii) Cypress has given you advance written authorization to use the product as a Critical Component in the specific High-Risk Device and you have signed a separate indemnification agreement.

Cypress, the Cypress logo, Spansion, the Spansion logo, and combinations thereof, WICED, PSoC, CapSense, EZ-USB, F-RAM, and Traveo are trademarks or registered trademarks of Cypress in the United States and other countries. For a more complete list of Cypress trademarks, visit cypress.com. Other names and brands may be claimed as property of their respective owners.

Looking for pricing, stock, or lifecycle information?

Click below to explore more details on WIN SOURCE:

 [View CY62167G30-45ZXI on WIN SOURCE](#)

 [Infineon Technologies](#) Information

Optimize Your Supply Chain with WIN SOURCE Solutions

-  Global Sourcing Solution
-  Obsolete Management
-  Cost Control Management
-  Shortage Management
-  Alternative Solution
-  Excess Inventory Management