



# THE DATASHEET OF TAS2505TRGERQ1



# ***TAS2505 Application Reference Guide***

## ***User's Guide***

---



Literature Number: SLAU472C  
FEBRUARY 2013 – REVISED NOVEMBER 2023



# Table of Contents



<b>1 TAS2505 Device Overview</b>	7
<b>2 Description</b>	9
2.1 Typical Circuit Configuration	10
2.2 Circuit Configuration with Internal LDO	11
<b>3 TAS2505 Application</b>	13
3.1 Terminal Descriptions	13
3.1.1 Digital Pins	13
3.1.2 Analog Pins	13
3.1.3 Multifunction Pins	13
3.1.4 Register Settings for Multifunction Pins	15
3.2 Audio Analog I/O	16
3.3 Analog Signals	16
3.3.1 Analog Inputs AINL and AINR	16
3.4 Audio DAC and Audio Analog Outputs	16
3.4.1 DAC	17
3.4.2 DAC Gain Setting	22
3.4.3 Interrupts	22
3.4.4 Programming DAC Digital Filter Coefficients	22
3.4.5 Updating DAC Digital Filter Coefficients During PLAY	23
3.4.6 Digital Mixing and Routing	25
3.4.7 Analog Audio Routing	25
3.4.8 Analog Outputs	26
3.4.9 Audio Output-Stage Power Configurations	28
3.4.10 5V LDO	29
3.4.11 POR	30
3.4.12 DAC Setup	31
3.5 PowerTune	32
3.5.1 PowerTune Modes	32
3.5.2 DAC Power Consumption	33
3.5.3 Speaker output Power Consumption	35
3.5.4 Headphone output Power Consumption	36
3.6 CLOCK Generation and PLL	37
3.6.1 PLL	39
3.7 Digital Audio and Control Interface	41
3.7.1 Digital Audio Interface	41
3.7.2 Control Interface	47
3.8 Power Supply	49
3.8.1 System Level Considerations	50
3.9 Device Special Functions	51
3.9.1 Interrupts	51
<b>4 Device Initialization</b>	53
4.1 Power On Sequence	53
4.1.1 Power On Sequence 1 – Separate Digital and Analog Supplies	53
4.1.2 Power On Sequence 2 – Shared 1.8 V Analog Supply to DVDD	54
4.2 Device Initialization	56
4.2.1 Reset by RST pin and POR	56
4.2.2 Device Start-Up Lockout Times	56
4.2.3 PLL Start-Up	56
4.2.4 Power-Stage Reset	56

4.2.5 Software Power Down.....	56
4.2.6 Device Common Mode Voltage.....	57
<b>5 Example Setups.....</b>	<b>59</b>
5.1 Example Register Setup to Play Digital Data Through DAC and Headphone/Speaker Outputs.....	59
5.2 Example Register Setup to Play Digital Data Through DAC and Headphone Output.....	60
5.3 Example Register Setup to Play AINL and AINR Through Headphone/Speaker Outputs.....	61
5.4 Example Register Setup to Play AINL and AINR Through Headphone Output.....	61
5.5 Example Register Setup to Play Digital Data Through DAC and Headphone/Speaker Outputs With 3 Programmable Biquads.....	62
5.6 Example Register Setup to Play Digital Data Through DAC and Headphone/Speaker Outputs With 6 Programmable Biquads.....	63
<b>6 Register Map.....</b>	<b>67</b>
6.1 TAS2505 Register Map.....	67
6.1.1 Control Registers, Page 0 (Default Page): Clock Multipliers, Dividers, Serial Interfaces, Flags, Interrupts, and GPIOs.....	68
6.1.2 Control Registers, Page 1: DAC Routing, Power-Controls and MISC Logic Related Programmabilities.....	79
6.1.3 Page 2 - 43: Reserved Register.....	92
6.1.4 Page 44: DAC Programmable Coefficients RAM.....	92
6.1.5 Page 45 - 52: DAC Programmable Coefficients RAM.....	93
6.1.6 Page 53 - 61: Reserved Register.....	93
6.1.7 Page 62 - 70: DAC Programmable Coefficients RAM.....	93
6.1.8 Pages 71 – 255: Reserved Register.....	94
6.1.9 DAC Coefficients A+B.....	95
6.1.10 DAC Defaults.....	97
<b>7 Revision History.....</b>	<b>98</b>

## **Trademarks**

All trademarks are the property of their respective owners.

This page intentionally left blank.



- **Chapter 1: Device Overview**
- [Chapter 3: TAS2505 Application](#)
- [Chapter 4: Device Initialization](#)
- [Chapter 5: Example Setups](#)
- [Chapter 6: Register Map and Descriptions](#)

#### Features

- Digital input mono speaker amp
- Supports 8-kHz to 96-kHz sample rates
- Mono class-D BTL speaker driver (2.0 W into 4  $\Omega$  or 1.7 W into 8  $\Omega$ )
- Mono headphone, line out driver
- Two single-ended inputs with output mixing and level control
- Embedded power-on-reset
- Integrated LDO
- Programmable digital audio processing blocks for bass boost, treble, EQ with up to six biquads for playback
- Integrated PLL used for programmable digital audio processing blocks
- I<sup>2</sup>S, left-justified, right-justified, DSP, and TDM audio interfaces
- I<sup>2</sup>C and SPI control with auto-increment
- Full power-down control
- Power supplies:
  - Analog: 1.5 V to 1.95 V
  - Digital Core: 1.65 V to 1.95 V
  - Digital I/O: 1.1 V to 3.6 V
  - Class-D: 2.7 V to 5.5 V (SPKVDD  $\geq$  AVDD)
- 4-mm  $\times$  4-mm 24-pin QFN package

#### Applications

- Portable audio devices
- White goods
- Portable navigation devices

This page intentionally left blank.



The TAS2505 is a low power digital input speaker amp with support for 24-bit digital I2S data mono playback.

In addition to driving a speaker amp up to 4-Ω, the device also features a mono headphone driver and a programmable digital-signal processing block. The digital audio data format is programmable to work with popular audio standard protocols (I<sup>2</sup>S, left/right-justified) in master, slave, DSP and TDM modes. The programmable digital-signal processing block can support Bass boost, treble, or EQ functions. An on-chip PLL provides the high-speed clock needed by the digital signal-processing block. The volume level can be controlled by register control. The audio functions are controlled using the I2C serial bus or SPI bus. The device includes an on-board LDO that runs off the speaker power supply to handle all internal device analog and digital power needs. The included POR as power-on-reset circuit reliably resets the device into its default state so no external reset is required at normal usage; however, the device does have a reset pin for more complex system initialization needs. The device also includes two analog inputs for mixing and muxing in both speaker and headphone analog paths.

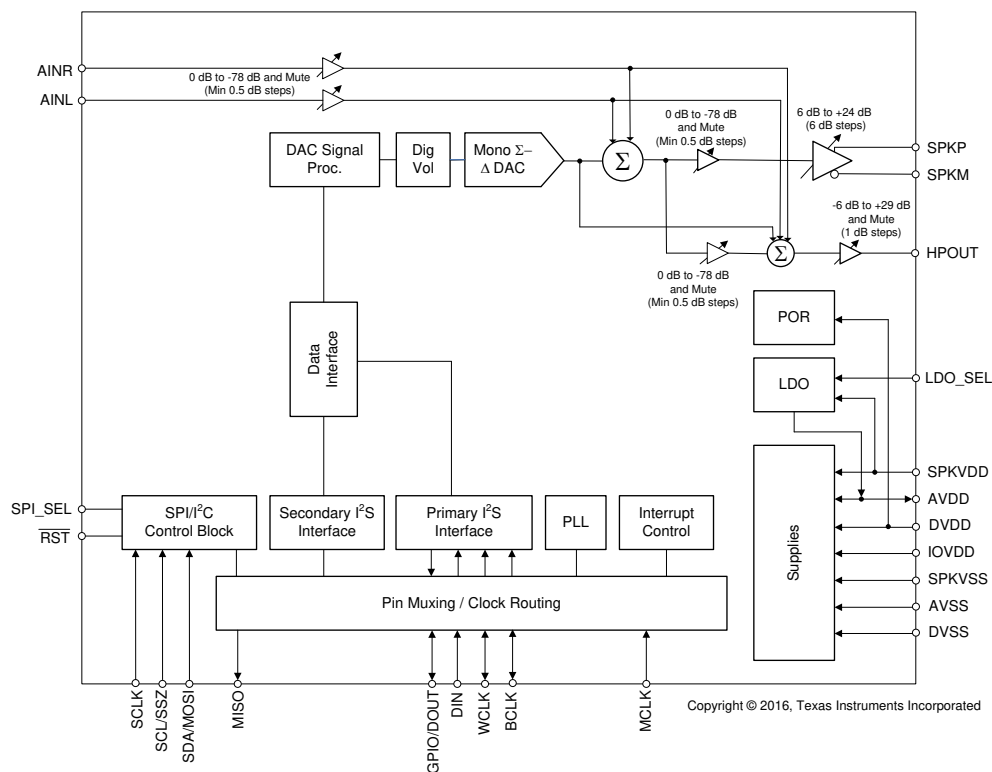
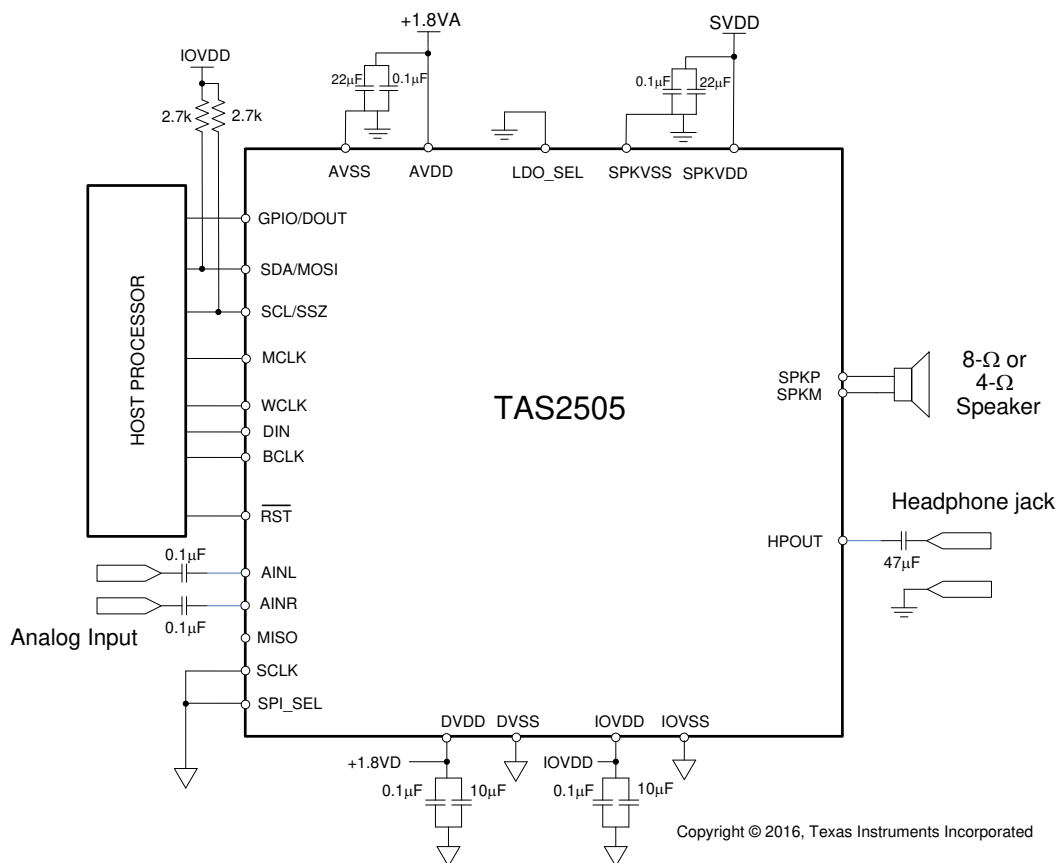


Figure 2-1. Simplified Block Diagram

The device can cover operations from 8kHz mono playback to mono 96kHz DAC playback, making it ideal for portable battery-powered audio and telephony applications. The playback path offers signal processing blocks for filtering and effects, flexible mixing of analog input signals as well as programmable volume controls. The voltage supply range for the TAS2505 for analog is 1.5V–1.95V, and for digital it is 1.65V–1.95V. To ease system-level design, a low-dropout regulator (LDO) is integrated to generate the appropriate analog supply from input voltages ranging from 2.7V to 5.5V. Digital I/O voltages are supported in the range of 1.1V–3.6V. The required internal clock of the TAS2505 can be derived from multiple sources, including the MCLK, BCLK or GPIO/DOUT pins or the output of the internal PLL, where the input to the PLL again can be derived from the MCLK, BCLK or GPIO/DOUT pins. Although using the internal, fractional PLL ensures the availability of a suitable clock signal, it is not recommended for the lowest power settings. The PLL is highly programmable and can accept available input clocks in the range of 512kHz to 50MHz.

The device is available in the 4mm × 4mm, 24-pin QFN package.

## 2.1 Typical Circuit Configuration



**Figure 2-2. Typical Circuit Configuration**

## 2.2 Circuit Configuration with Internal LDO

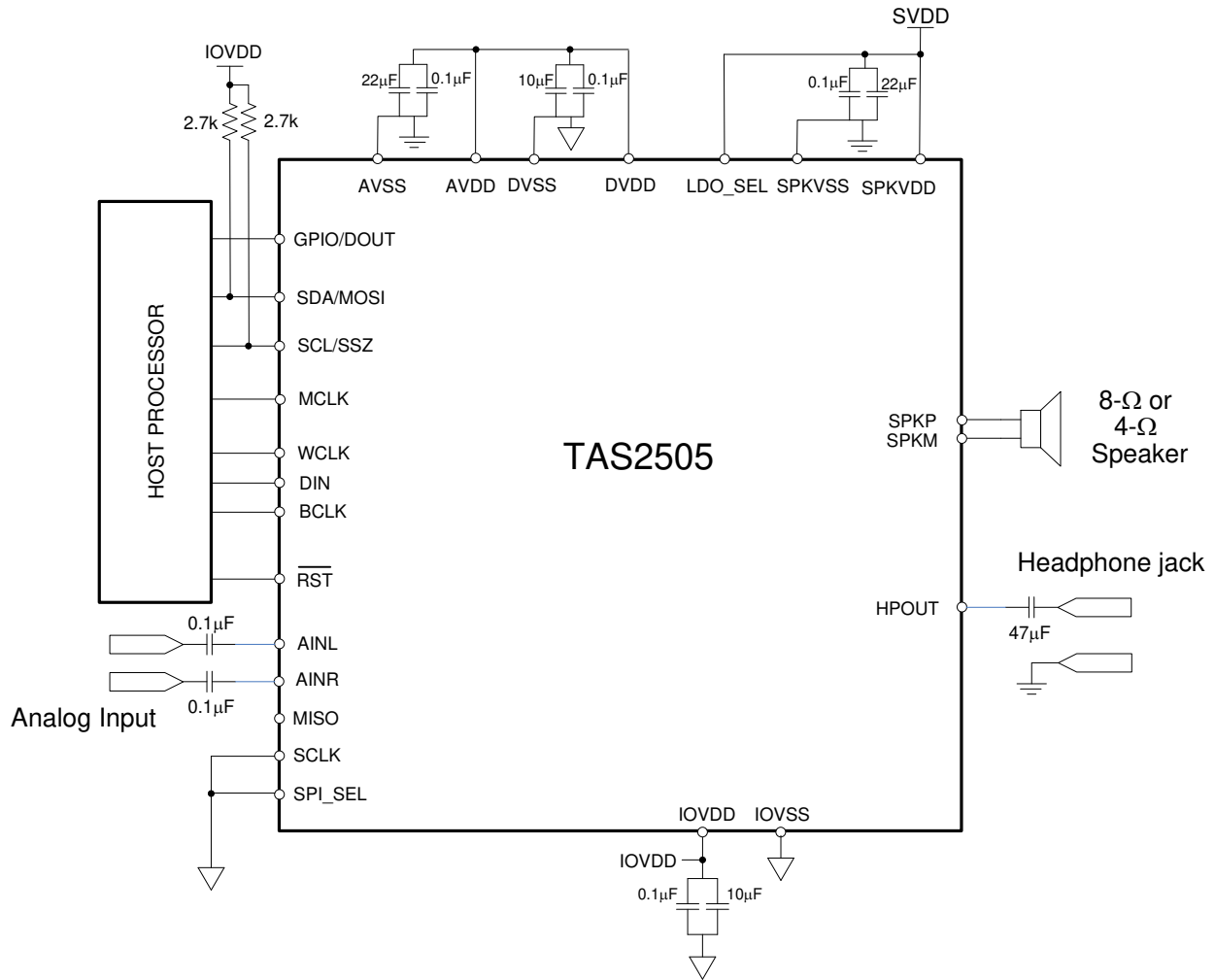


Figure 2-3. Application Schematics for LDO

This page intentionally left blank.



### 3.1 Terminal Descriptions

#### 3.1.1 Digital Pins

Only a small number of digital pins are dedicated to a single function; whenever possible, the digital pins have a default function, and also can be reprogrammed to cover alternative functions for various applications.

The fixed-function pins are  $\overline{\text{RST}}$  LDO\_SEL and the SPI\_SEL pin, which are HW control pins. Depending on the state of SPI\_SEL, the two control-bus pins SCL/SS $\overline{\text{Z}}$  and SDA/MOSI are configured for either I<sup>2</sup>C or SPI protocol.

Other digital IO pins can be configured for various functions via register control. An overview of available functionality is given in [Section 3.1.3](#).

#### 3.1.2 Analog Pins

Analog functions can also be configured to a large degree. For minimum power consumption, analog blocks are powered down by default. The blocks can be powered up with fine granularity according to the application needs.

#### 3.1.3 Multifunction Pins

[Table 3-1](#) shows the possible allocation of pins for specific functions. The PLL input, for example, can be programmed to be any of 4 pins (MCLK, BCLK, DIN, GPIO).

**Table 3-1. Multifunction Pin Assignments**

		1	2	3	4	5	6	7
	Pin Function	MCLK	BCLK	WCLK	DIN	GPIO /DOUT	SCLK	MISO
<b>A</b>	PLL Input	S <sup>(2)</sup>	S <sup>(3)</sup>		E	S <sup>(4)</sup>		
<b>B</b>	Codec Clock Input	S <sup>(2)</sup> ,D <sup>(5)</sup>	S <sup>(3)</sup>			S <sup>(4)</sup>		
<b>C</b>	I <sup>2</sup> S BCLK input		S <sup>(3)</sup> ,D					
<b>D</b>	I <sup>2</sup> S BCLK output		E <sup>(1)</sup>					
<b>E</b>	I <sup>2</sup> S WCLK input			E, D				
<b>F</b>	I <sup>2</sup> S WCLK output			E				
<b>G</b>	I <sup>2</sup> S DIN				E, D			
<b>I</b>	General Purpose Output I					E		
<b>I</b>	General Purpose Output II							E
<b>J</b>	General Purpose Input I				E			
<b>J</b>	General Purpose Input II					E		
<b>J</b>	General Purpose Input III						E	
<b>K</b>	INT1 output					E		E
<b>L</b>	INT2 output					E		E
<b>M</b>	Secondary I <sup>2</sup> S BCLK input					E	E	
<b>N</b>	Secondary I <sup>2</sup> S WCLK input					E	E	
<b>O</b>	Secondary I <sup>2</sup> S DIN					E	E	

**Table 3-1. Multifunction Pin Assignments (continued)**

		1	2	3	4	5	6	7
	Pin Function	MCLK	BCLK	WCLK	DIN	GPIO /DOUT	SCLK	MISO
<b>P</b>	Secondary I <sup>2</sup> S BCLK OUT					E		E
<b>Q</b>	Secondary I <sup>2</sup> S WCLK OUT					E		E
<b>R</b>	Secondary I <sup>2</sup> S DOUT							E
<b>S</b>	Aux Clock Output					E		E

- (1) E: The pin is **exclusively** used for this function, no other function can be implemented with the same pin. (If GPIO/DOUT has been allocated for General Purpose Output, it cannot be used as the INT1 output at the same time.)
- (2) S<sup>(1)</sup>: The MCLK pin can drive the PLL and Codec Clock inputs **simultaneously**.
- (3) S<sup>(2)</sup>: The BCLK pin can drive the PLL and Codec Clock and audio interface bit clock inputs **simultaneously**.
- (4) S<sup>(3)</sup>: The GPIO/DOUT pin can drive the PLL and Codec Clock inputs **simultaneously**.
- (5) D: Default Function

### 3.1.4 Register Settings for Multifunction Pins

To configure the settings seen in [Table 3-1](#), please see the letter-number combination in [Table 3-2](#) for the appropriate registers to modify. In [Table 3-2](#), the letter/number combination represents the row and the column number from [Table 3-1](#) in bold type.

Please be aware that more settings may be necessary to obtain a full interface definition matching the application requirement (see Page 0, Register 25 to 33).

**Table 3-2. Multifunction Pin Register Configuration**

	Description	Required Register Setting		Description	Required Register Setting
A1	PLL Input on MCLK	Page 0, Register 4, Bits D3-D2 = 00	K7	INT1 output on MISO	Page 0, Register 55, Bits D4-D1 = 0100
A2	PLL Input on BCLK	Page 0, Register 4, Bits D3-D2 = 01	L5	INT2 output GPIO/DOUT	Page 0, Register 52, Bits D5-D2 = 0110
A4	PLL Input on DIN/MFP1	Page 0, Register 54, Bits D2-D1 = 01 Page 0, Register 4, Bits D3-D2 = 11	L7	INT2 output on MISO	Page 0, Register 55, Bits D4-D1 = 0101
A5	PLL Input on GPIO/DOUT	Page 0, Register 52, Bits D5-D2 = 0001 Page 0, Register 4, Bits D3-D2 = 10	M5	Secondary I <sup>2</sup> S BCLK input on GPIO/DOUT	Page 0, Register 52, Bits D5-D2 = 0001 Page 0, Register 31, Bits D6-D5 = 00
B1	Codec Clock Input on MCLK	Page 0, Register 4, Bits D1-D0 = 00	M6	Secondary I <sup>2</sup> S BCLK input on SCLK	Page 0, Register 56, Bits D2-D1 = 01 Page 0, Register 31, Bits D6-D5 = 01
B2	Codec Clock Input on BCLK	Page 0, Register 4, Bits D1-D0 = 01	N5	Secondary I <sup>2</sup> S WCLK in on GPIO/DOUT	Page 0, Register 52, Bits D5-D2 = 0001 Page 0, Register 31, Bits D4-D3 = 00
B5	Codec Clock Input on GPIO/DOUT	Page 0, Register 52, Bits D5-D2 = 0001 Page 0, Register 4, Bits D1-D0 = 10	N6	Secondary I <sup>2</sup> S WCLK in on SCLK	Page 0, Register 56, Bits D2-D1 = 01 Page 0, Register 31, Bits D4-D3 = 01
C2	I <sup>2</sup> S BCLK input on BCLK	Page 0, Register 27, Bit D3 = 0	O5	Secondary I <sup>2</sup> S DIN on GPIO/DOUT	Page 0, Register 52, Bits D5-D2 = 0001 Page 0, Register 31, Bit D0 = 0
D2	I <sup>2</sup> S BCLK output on BCLK	Page 0, Register 27, Bit D3 = 1	O6	Secondary I <sup>2</sup> S DIN on SCLK	Page 0, Register 56, Bits D2-D1 = 01 Page 0, Register 31, Bit D0 = 1
E3	I <sup>2</sup> S WCLK input on WCLK	Page 0, Register 27, Bit D2 = 0	P5	Secondary I <sup>2</sup> S BCLK OUT on GPIO/DOUT	Page 0, Register 52, Bits D5-D2 = 1000
F3	I <sup>2</sup> S WCLK output WCLK	Page 0, Register 27, Bit D2 = 1	P7	Secondary I <sup>2</sup> S BCLK OUT on MISO	Page 0, Register 55, Bits D4-D1 = 1001
G4	I <sup>2</sup> S DIN on DIN	Page 0, Register 54, Bits D2-D1 = 01	Q5	Secondary I <sup>2</sup> S WCLK OUT on GPIO/DOUT	Page 0, Register 52, Bits D5-D2 = 1001
H5	N/A		Q7	Secondary I <sup>2</sup> S WCLK OUT on MISO	Page 0, Register 55, Bits D4-D1 = 1010

**Table 3-2. Multifunction Pin Register Configuration (continued)**

	Description	Required Register Setting		Description	Required Register Setting
I5	General Purpose Out I on GPIO/DOUT	Page 0, Register 53, Bits D3-D1 = 010	R7	Secondary I <sup>2</sup> S DOUT on MISO	Page 0, Register 55, Bits D4-D1 = 1000
I7	General Purpose Out II on MISO	Page 0, Register 55, Bits D4-D1 = 0010	S5	Aux Clock Output on GPIO/DOUT	Page 0, Register 52, Bits D5-D2 = 0100
J4	General Purpose In I on DIN	Page 0, Register 54, Bits D2-D1 = 10	S7	Aux Clock Output on MISO	Page 0, Register 55, Bits D4-D1 = 0011
J5	General Purpose In II on GPIO/DOUT	Page 0, Register 52, Bits D5-D2 = 0010			
J6	General Purpose In III on SCLK	Page 0, Register 56, Bits D2-D1 = 10			
K5	INT1 output on GPIO/DOUT	Page 0, Register 52, Bits D5-D2 = 0101			

### 3.2 Audio Analog I/O

The TAS2505 features a mono audio DAC. It supports a wide range of analog interfaces to support different headsets such as 16-Ω to 200-Ω impedance and analog line outputs. The TAS2505 can drive a speaker up to 4-Ω impedance.

### 3.3 Analog Signals

The TAS2505 analog signals consist of:

- Analog inputs AINR and AINL, which can be used to pass-through or mix analog signals to output stages
- Analog outputs class-D speaker driver and headphone/lineout driver providing output capability for the DAC, AINR, AINL, or a mix of the three

#### 3.3.1 Analog Inputs AINL and AINR

AINL (pin 3 or C2) and AINR (pin 4 or B2) are inputs to Mixer P and Mixer M along with the DAC output. Also AINL and AINR can be configured inputs to HP driver. Page1 / register 12 provides control signals for determining the signals routed through Mixer P, Mixer M and HP driver. Input of Mixer P can be attenuated by Page1 / register 24, input of Mixer M can be attenuated by Page1 / register 25 and input of HP driver can be attenuated by Page1 / register 22. Also AINL and AINR can be configured to a monaural differential input with use Mixer P and Mixer M by Page1 / register 12 setting. All the options can be viewed in the functional block diagram, [Figure 3-6](#).

### 3.4 Audio DAC and Audio Analog Outputs

The mono audio DAC consists of a digital audio processing block, a digital interpolation filter, a digital delta-sigma modulator, and an analog reconstruction filter. The high oversampling ratio (normally DOSR is between 32 and 128) exhibits good dynamic range by ensuring that the quantization noise generated within the delta-sigma modulator stays outside of the audio frequency band. Audio analog outputs include mono headphone and lineout and mono class-D speaker outputs. Because the TAS2505 contains a mono DAC, it inputs the mono data from the left channel, the right channel, or a mix of the left and right channels as  $[(L + R) \div 2]$ , selected by page 0, register 63, bits D5–D4. See [Figure 2-1](#) for the signal flow.

### 3.4.1 DAC

The TAS2505 mono audio DAC supports data rates from 8 kHz to 192 kHz. The audio channel of the mono DAC consists of a signal-processing engine with fixed processing blocks, a digital interpolation filter, multibit digital delta-sigma modulator, and an analog reconstruction filter. The DAC is designed to provide enhanced performance at low sampling rates through increased oversampling and image filtering, thereby keeping quantization noise generated within the delta-sigma modulator and observed in the signal images strongly suppressed within the audio band to beyond 20 kHz. To handle multiple input rates and optimize power dissipation and performance, the TAS2505 allows the system designer to program the oversampling rates over a wide range from 1 to 1024 by configuring page 0, register 13 and page 0 / register 14. The system designer can choose higher oversampling ratios for lower input data rates and lower oversampling ratios for higher input data rates.

The TAS2505 DAC channel includes a built-in digital interpolation filter to generate oversampled data for the delta-sigma modulator. The interpolation filter can be chosen from three different types, depending on required frequency response, group delay, and sampling rate.

DAC power up is controlled by writing to page 0, register 63, bit D7 for the mono channel. The mono-channel DAC clipping flag is provided as a read-only bit on page 0 / register 39, bit D7.

The DAC path of the TAS2505 features many options for signal conditioning and signal routing:

- Digital volume control with a range of -63.5 to +24dB
- Mute function

In addition to the standard set of DAC features the TAS2505 also offers the following special features:

- Digital auto mute
- Adaptive filter mode

#### 3.4.1.1 DAC Processing Blocks

The TAS2505 implements signal-processing capabilities and interpolation filtering via processing blocks. These fixed processing blocks give users the choice of how much and what type of signal processing they may use and which interpolation filter is applied.

The choices among these processing blocks allows the system designer to balance power conservation and signal-processing flexibility. [Table 3-3](#) gives an overview of all available processing blocks of the DAC channel and their properties. The resource-class column gives an approximate indication of power consumption for the digital (DVDD) supply; however, based on the out-of-band noise spectrum, the analog power consumption of the drivers (AVDD) may differ.

The signal-processing blocks available are:

- First-order IIR
- Scalable number of biquad filters

The processing blocks are tuned for common cases and can achieve high image rejection or low group delay in combination with various signal-processing effects such as audio effects and frequency shaping. The available first-order IIR and biquad filters have fully user-programmable coefficients.

**Table 3-3. Overview – DAC Predefined Processing Blocks**

Processing Block No.	Interpolation Filter	Channel	First-Order IIR Available	Number of Biquads	Resource Class
PRB_P1	A	Mono	Yes	6	6
PRB_P2	A	Mono	No	3	4
PRB_P3	B	Mono	Yes	6	4

### 3.4.1.2 DAC Processing Blocks – Signal Chain Details

#### 3.4.1.2.1 Three Biquads, Filter A

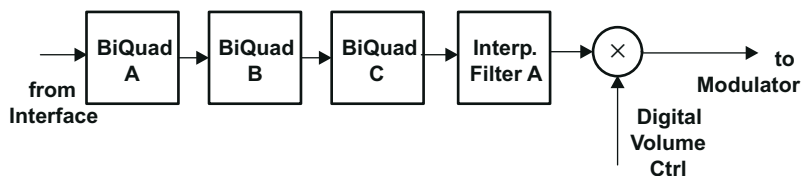


Figure 3-1. Signal Chain for PRB\_P2

#### 3.4.1.2.2 Six Biquads, First-Order IIR, Filter A or B

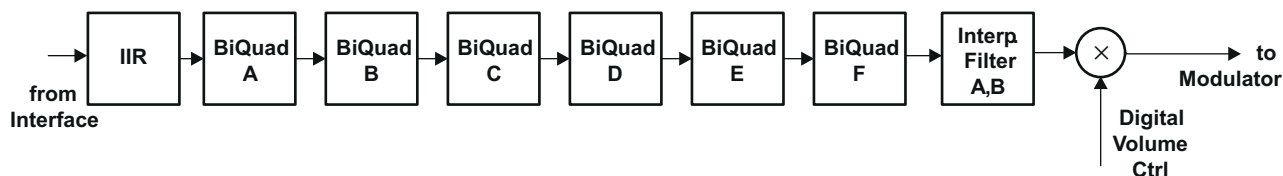


Figure 3-2. Signal Chain for PRB\_P1 and PRB\_P3

### 3.4.1.3 DAC User-Programmable Filters

Depending on the selected processing block, different types and orders of digital filtering are available. Up to six biquad sections are available for specific processing blocks.

The coefficients of the available filters are arranged as sequentially-indexed coefficients in two banks. If adaptive filtering is chosen, the coefficient banks can be switched in real time.

When the DAC is running, the user-programmable filter coefficients are locked and cannot be accessed for either read or write.

However, the TAS2505 offers an adaptive filter mode as well. Setting page 8, register 1, bit D2 = 1 turns on double buffering of the coefficients. In this mode, filter coefficients can be updated through the host and activated without stopping and restarting the DAC. This enables advanced adaptive filtering applications.

In the double-buffering scheme, all coefficients are stored in two buffers (buffers A and B). When the DAC is running and adaptive filtering mode is turned on, setting page 44, register 1, bit D0 = 1 switches the coefficient buffers at the next start of a sampling period. This bit is set back to 0 after the switch occurs. At the same time, page 44, register 1, bit D1 toggles.

The flag in page 44, register 1, bit D1 indicates which of the two buffers is actually in use.

Page 44, register 1, bit D1 = 0: buffer A is in use by the DAC engine; bit D1 = 1: buffer B is in use.

While the device is running, coefficient updates are always made to the buffer not in use by the DAC, regardless of the buffer to which the coefficients have been written.

**Table 3-4. Adaptive-Mode Filter-Coefficient Buffer Switching**

DAC Powered Up	Page 44, Reg 1, Bit D1	Coefficient Buffer in Use	I <sup>2</sup> C Writes to	Will Updates
No	0	None	C1, buffer A	C1, buffer A
No	0	None	C1, buffer B	C1, buffer B
Yes	0	Buffer A	C1, buffer A	C1, buffer B
Yes	0	Buffer A	C1, buffer B	C1, buffer B
Yes	1	Buffer B	C1, buffer A	C1, buffer A
Yes	1	Buffer B	C1, buffer B	C1, buffer A

The user-programmable coefficients C1 to C70 for the DAC processing blocks are defined on pages 44 to 46 for buffer A and pages 62 to 64 for buffer B.

The coefficients of these filters are each 24-bit, 2s-complement format, occupying three consecutive 8-bit registers in the register space. Specifically, the filter coefficients are in 1.23 (one dot 23) format with a range from –1.0 (0x800000) to 0.99999988079071044921875 (0x7FFFFFFF).

#### 3.4.1.3.1 First-Order IIR Section

The IIR is of first order and its transfer function is given by

$$H(z) = \frac{N_0 + N_1 z^{-1}}{2^{23} - D_1 z^{-1}} \quad (1)$$

The frequency response for the first-order IIR section with default coefficients is flat.

**Table 3-5. DAC IIR Filter Coefficients**

Filter	Filter Coefficient	DAC Coefficient, Mono Channel	Default (Reset) Values
First-order IIR	N0	C65 (Page 46/ registers 28,29,30)	0x7FFFFFFF
	N1	C66 (Page 46/ registers 32,33,34)	0x000000
	D1	C67 (Page 46 / registers 36,37,38)	0x000000

#### 3.4.1.3.2 Biquad Section

The transfer function of each of the biquad filters is given by

$$H(z) = \frac{N_0 + 2 \times N_1 z^{-1} + N_2 z^{-2}}{2^{23} - 2 \times D_1 z^{-1} - D_2 z^{-2}} \quad (2)$$

**Table 3-6. DAC Biquad Filter Coefficients**

Filter	Coefficient	Mono DAC Channel	Default (Reset) Values
Biquad A	N0	C1 (Page 44, registers 12, 13, 14)	0x7FFFFFFF
	N1	C2 (Page 44, registers 16, 17, 18)	0x000000
	N2	C3 (Page 44, registers 20, 21, 22)	0x000000
	D1	C4 (Page 44, registers 24, 25, 26)	0x000000
	D2	C5 (Page 44, registers 28, 29, 30)	0x000000
Biquad B	N0	C6 (Page 44, registers 32, 33, 34)	0x7FFFFFFF
	N1	C7 (Page 44, registers 36, 37, 38)	0x000000
	N2	C8 (Page 44, registers 40, 41, 42)	0x000000
	D1	C9 (Page 44, registers 44, 45, 46)	0x000000
	D2	C10 (Page 44, registers 48, 49, 50)	0x000000

**Table 3-6. DAC Biquad Filter Coefficients (continued)**

Filter	Coefficient	Mono DAC Channel	Default (Reset) Values
Biquad C	N0	C11 (Page 44, registers 52, 53, 54)	0x7FFFFFFF
	N1	C12 (Page 44, registers 56, 57, 58)	0x000000
	N2	C13 (Page 44, registers 60, 61, 62)	0x000000
	D1	C14 (Page 44, registers 64, 65, 66)	0x000000
	D2	C15 (Page 44, registers 68, 69, 70)	0x000000
Biquad D	N0	C16 (Page 44, registers 72, 73, 74)	0x7FFFFFFF
	N1	C17 (Page 44, registers 76, 77, 78)	0x000000
	N2	C18 (Page 44, registers 80, 81, 82)	0x000000
	D1	C19 (Page 44, registers 84, 85, 86)	0x000000
	D2	C20 (Page 44, registers 88, 89, 90)	0x000000
Biquad E	N0	C21 (Page 44, registers 92, 93, 94)	0x7FFFFFFF
	N1	C22 (Page 44, registers 96, 97, 98)	0x000000
	N2	C23 (Page 44, registers 100, 101, 102)	0x000000
	D1	C24 (Page 44, registers 104, 105, 106)	0x000000
	D2	C25 (Page 44, registers 108, 109, 110)	0x000000
Biquad F	N0	C26 (Page 44, registers 112, 113, 114)	0x7FFFFFFF
	N1	C27 (Page 44, registers 116, 117, 118)	0x000000
	N2	C28 (Page 44, registers 120, 121, 122)	0x000000
	D1	C29 (Page 44, registers 124, 125, 126)	0x000000
	D2	C30 (Page 45, registers 8, 9, 10)	0x000000

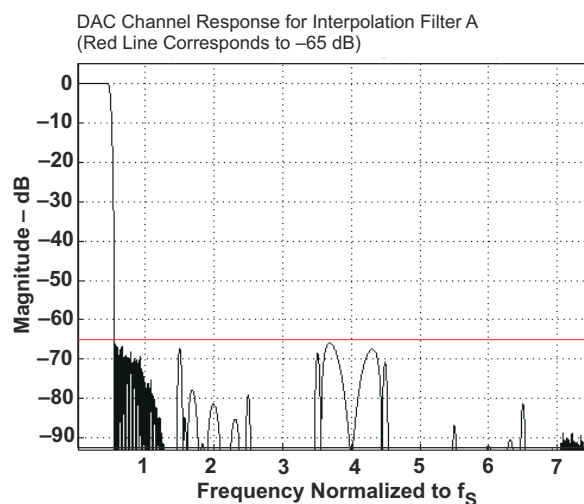
### 3.4.1.4 DAC Interpolation Filter Characteristics

#### 3.4.1.4.1 Interpolation Filter A

Filter A is designed for an  $f_S$  up to 48 ksp/s with a flat pass band of 0 kHz–20 kHz.

**Table 3-7. Specification for DAC Interpolation Filter A**

Parameter	Condition	Value (Typical)	Unit
Filter-gain pass band	0 ... 0.45 $f_S$	$\pm 0.015$	dB
Filter-gain stop band	0.55 $f_S$ ... 7.455 $f_S$	-65	dB
Filter group delay		21/ $f_S$	s

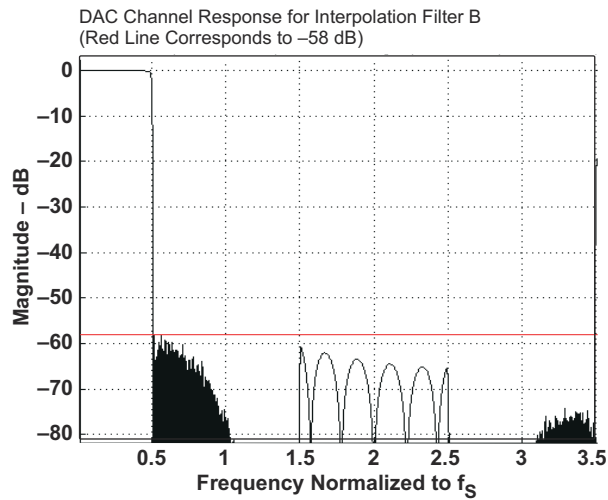

**Figure 3-3. Frequency Response of DAC Interpolation Filter A**

**3.4.1.4.2 Interpolation Filter B**

Filter B is specifically designed for an  $f_s$  up to 96 ksp/s. Thus, the flat pass-band region easily covers the required audio band of 0 kHz–20 kHz.

**Table 3-8. Specification for DAC Interpolation Filter B**

Parameter	Condition	Value (Typical)	Unit
Filter-gain pass band	$0 \dots 0.45 f_s$	$\pm 0.015$	dB
Filter-gain stop band	$0.55 f_s \dots 3.45 f_s$	-58	dB
Filter group delay		$18/f_s$	s



**Figure 3-4. Frequency Response of Channel Interpolation Filter B**

### 3.4.2 DAC Gain Setting

#### 3.4.2.1 PowerTune Modes

As part of the PowerTune strategy, the analog properties of the DAC are adjusted. As a consequence, the full-scale signal swing achieved at the headphone and line outputs must be adjusted. Please see [Table 3-9](#) for the proper gain compensation values across the different combinations.

**Table 3-9. DAC Gain vs. PowerTune Modes**

DAC PowerTune Mode Control Page 1, Register 3, Bits (D4-D2)	PowerTune Mode	Headphone Gain	
		CM = 0.75V, Gain for 375mV <sub>RMS</sub> output swing at 0dB full scale input	CM = 0.9V, Gain for 500mV <sub>RMS</sub> output swing at 0dB full scale input
000	PTM_P3, PTM_P4	0	0
001	PTM_P2	4	4
010	PTM_P1	14	14

#### 3.4.2.2 DAC Digital-Volume Control

The DAC has a digital volume-control block which implements programmable gain. Each channel has an independent volume control that can be varied from 24 dB to –63.5 dB in 0.5-dB steps. The mono-channel DAC volume can be controlled by writing to page 0, register 65, bits D7–D0. DAC muting and setting up a master gain control to control the mono channel is done by writing to page 0, register 64, bits D3. The gain is implemented with a soft-stepping algorithm, which only changes the actual volume by 0.125 dB per input sample, either up or down, until the desired volume is reached. The rate of soft-stepping can be slowed to one step per two input samples by writing to page 0, register 63, bits D1–D0. Note that the default source for volume-control level settings is controlled by register writes to page 0, register 65.

During soft-stepping, the host does not receive a signal when the DAC has been completely muted. This may be important if the host must mute the DAC before making a significant change, such as changing sample rates. In order to help with this situation, the device provides a flag back to the host via a read-only register, page 0, register 38, bit D4 for the mono channel. This information alerts the host when the part has completed the soft-stepping, and the actual volume has reached the desired volume level. The soft-stepping feature can be disabled by writing to page 0, register 63, bits D1–D0.

If soft-stepping is enabled, the CODEC\_CLKIN signal should be kept active until the DAC power-up flag is cleared. When this flag is cleared, the internal DAC soft-stepping process is complete, and CODEC\_CLKIN can be stopped if desired. (The analog volume control can be ramped down using an internal oscillator.)

#### 3.4.3 Interrupts

Some specific events in the TAS2505, which may require host-processor intervention, can be used to trigger interrupts to the host processor. This avoids polling the status-flag registers continuously. The TAS2505 has two defined interrupts, INT1 and INT2, that can be configured by programming page 0, register 48 and page 0, register 49. A user can configure interrupts INT1 and INT2 to be triggered by one or many events, such as:

- Overcurrent condition in headphone drivers/speaker drivers
- Data overflow in the DAC processing blocks and filters

Each of these INT1 and INT2 interrupts can be routed to output pin GPIO. These interrupt signals can either be configured as a single pulse or a series of pulses by programming page 0, register 48, bit D0 and page 0, register 49, bit D0. If the user configures the interrupts as a series of pulses, the events trigger the start of pulses that stop when the flag registers in page 0, register 42 and page 0, register 44 are read by the user to determine the cause of the interrupt.

#### 3.4.4 Programming DAC Digital Filter Coefficients

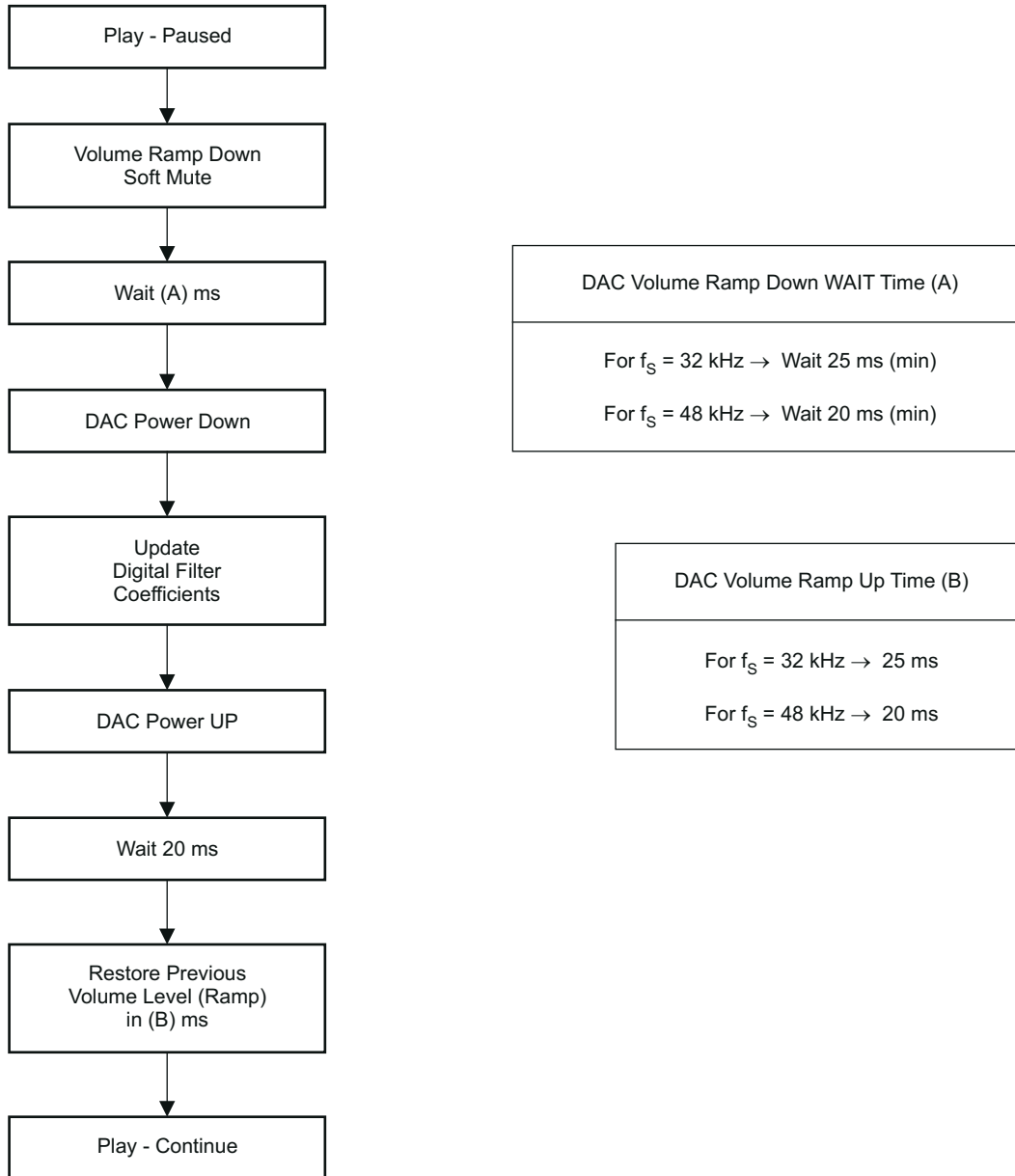
The digital filter coefficients must be programmed through the control interface. All digital filtering for the DAC signal path must be loaded into the RAM before the DAC is powered on. (Note that default ALLPASS filter coefficients for programmable biquads are located in boot ROM. The boot ROM automatically loads the default

values into the RAM following a hardware reset (toggling the  $\overline{\text{RST}}$  pin) or after a software reset. After resetting the device, loading boot ROM coefficients into the digital filters requires 100  $\mu\text{s}$  of programming time. During this time, reading or writing to page 8 through page 15 for updating DAC filter coefficient values is not permitted. (The DAC should not be powered up until after all of the DAC configurations have been done by the system microprocessor.)

### 3.4.5 Updating DAC Digital Filter Coefficients During PLAY

When it is required to update the DAC digital filter coefficients during play, care must be taken to avoid click and pop noise or even a possible oscillation noise. These artifacts can occur if the DAC coefficients are updated without following the proper update sequence. The correct sequence is shown in [Figure 3-5](#). The values for times listed in [Figure 3-5](#) are conservative and should be used for software purposes.

There is also an adaptive mode, in which DAC coefficients can be updated while the DAC is on. For details, see [Section 3.4.1.3](#).



F0024-02

**Figure 3-5. Example Flow For Updating DAC Digital Filter Coefficients During Play**

### 3.4.6 Digital Mixing and Routing

The TAS2505 has four digital mixing blocks. Each mixer can provide either mixing or multiplexing of the digital audio data. The first mixer/multiplexer can be used to select input data for the mono DAC from left channel, right channel, or (left channel + right channel) / 2 mixing. This digital routing can be configured by writing to page 0, register 63, bits D5–D4.

### 3.4.7 Analog Audio Routing

The TAS2505 has the capability to route the DAC output to either the headphone or the speaker output. If desirable, both output drivers can be operated at the same time while playing at different volume levels. The TAS2505 provides various digital routing capabilities, allowing digital mixing or even channel swapping in the digital domain. All analog outputs other than the selected ones can be powered down for optimal power consumption.

#### 3.4.7.1 Analog Output Volume Control

The output volume control can be used to fine-tune the level of the mixer amplifier signal supplied to the headphone driver or the speaker driver. This architecture supports separate and concurrent volume levels for each of the four output drivers. This volume control can also be used as part of the output pop-noise reduction scheme. This feature is available even if the DAC is powered down.

#### 3.4.7.2 Headphone Analog Output Volume Control

For the headphone output, the analog volume control has a range from 0 dB to –78 dB in 0.5-dB steps for most of the useful range plus mute, as shown in [Table 3-10](#). This volume control includes soft-stepping logic.

Changing the analog volume for the headphone is controlled by writing to page 1, register 22, bits D6–D0. Routing the signal from the output of the analog volume control to the input of the headphone power amplifier via Mixer P and Mixer M is done by writing to page 1, register 12, bit D2.

The analog volume-control soft-stepping time is based on the setting in page 0, register 63, bits D1–D0.

**Table 3-10. Analog Volume Control for Headphone and Speaker Outputs**

Register Value	Analog Attenuation (dB)	Register Value	Analog Attenuation (dB)	Register Value	Analog Attenuation (dB)	Register Value	Analog Attenuation (dB)
0	0.0	30	-15.0	60	-30.1	90	-45.2
1	-0.5	31	-15.5	61	-30.6	91	-45.8
2	-1.0	32	-16.0	62	-31.1	92	-46.2
3	-1.5	33	-16.5	63	-31.6	93	-46.7
4	-2.0	34	-17.0	64	-32.1	94	-47.4
5	-2.5	35	-17.5	65	-32.6	95	-47.9
6	-3.0	36	-18.1	66	-33.1	96	-48.2
7	-3.5	37	-18.6	67	-33.6	97	-48.7
8	-4.0	38	-19.1	68	-34.1	98	-49.3
9	-4.5	39	-19.6	69	-34.6	99	-50.0
10	-5.0	40	-20.1	70	-35.2	100	-50.3
11	-5.5	41	-20.6	71	-35.7	101	-51.0
12	-6.0	42	-21.1	72	-36.2	102	-51.4
13	-6.5	43	-21.6	73	-36.7	103	-51.8
14	-7.0	44	-22.1	74	-37.2	104	-52.2
15	-7.5	45	-22.6	75	-37.7	105	-52.7
16	-8.0	46	-23.1	76	-38.2	106	-53.7
17	-8.5	47	-23.6	77	-38.7	107	-54.2
18	-9.0	48	-24.1	78	-39.2	108	-55.3
19	-9.5	49	-24.6	79	-39.7	109	-56.7
20	-10.0	50	-25.1	80	-40.2	110	-58.3
21	-10.5	51	-25.6	81	-40.7	111	-60.2
22	-11.0	52	-26.1	82	-41.2	112	-62.7
23	-11.5	53	-26.6	83	-41.7	113	-64.3
24	-12.0	54	-27.1	84	-42.1	114	-66.2
25	-12.5	55	-27.6	85	-42.7	115	-68.7
26	-13.0	56	-28.1	86	-43.2	116	-72.2
27	-13.5	57	-28.6	87	-43.8	117-127	-78.3
28	-14.0	58	-29.1	88	-44.3		
29	-14.5	59	-29.6	89	-44.8		

### 3.4.7.3 Class-D Speaker Analog Output Volume Control

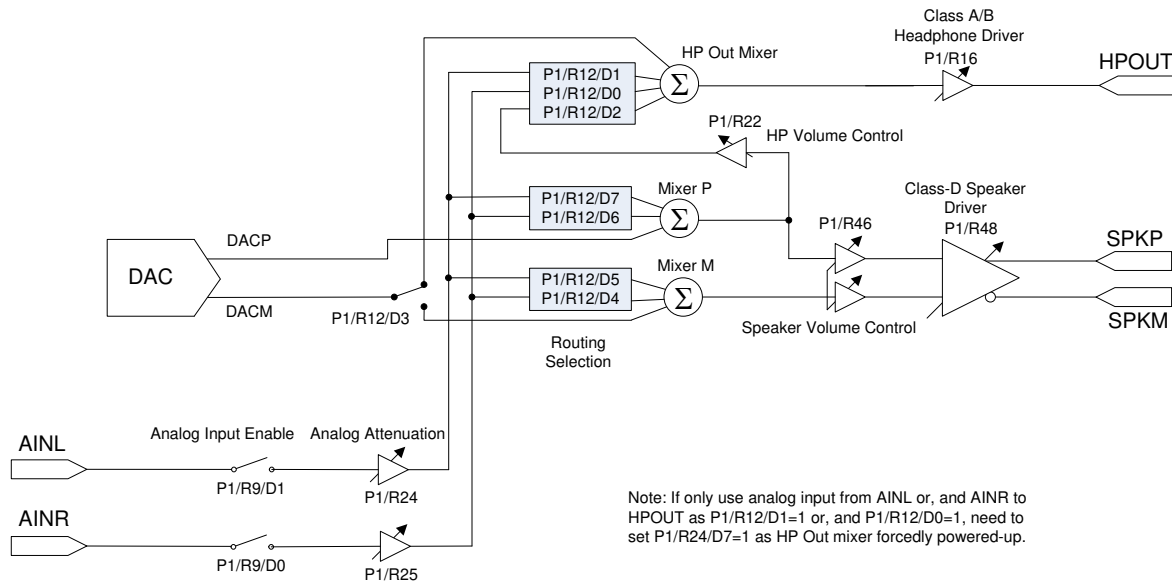
For the speaker outputs, the analog volume control has a range from 0 dB to -78 dB in 0.5-dB steps for most of the useful range plus mute, as seen in [Table 3-10](#). The implementation includes soft-stepping logic.

Routing the DAC output signal to the analog volume control via Mixer P and Mixer M is done by writing to page 1, register 12, bits D3. Changing the analog volume for the speaker is controlled by writing to page 1 / register 46, bits D6-D0.

The analog volume-control soft-stepping time is based on the setting in page 0, register 63, bits D1-D0.

### 3.4.8 Analog Outputs

Various analog routings are supported for playback. All the options can be viewed in the functional block diagram, [Figure 3-6](#).



**Figure 3-6. Analog Block Diagram**

### 3.4.8.1 Headphone Drivers

The TAS2505 features a mono headphone driver (HPOUT) that can deliver up to 28 mW channel, at 1.8-V supply voltage, into a 16- $\Omega$  load. The headphones are used in a single-ended configuration where an ac-coupling (dc-blocking) capacitor is connected between the device output pins and the headphones. The headphone driver also supports 32- $\Omega$  and 10-k $\Omega$  loads without changing any control register settings.

The headphone driver can be configured to reduce the power consumption in the half drive ability mode by writing 1 to page 1, register 10, bits D2 = 1, also in this mode the headphone driver can support lineout-drive as well.

The common-mode voltage is set to  $\leq AVDD/2$ .

The headphone driver can be powered on by writing to page 1, register 9, bit D5. The HPOUT output driver gain can be controlled by writing to page 1 / register 16 bits D5–D0, and it can be muted by writing to page 1, register 16, bit D6.

The TAS2505 has a short-circuit protection feature for the headphone drivers, which is always enabled to provide protection. The output condition of the headphone driver during short circuit can be programmed by writing to page 1, register 11, bit D1. If D1 = 0 when a short circuit is detected, the device limits the maximum current to the load. If D1 = 1 when a short circuit is detected, the device powers down the output driver. The default condition for headphones is the current-limiting mode. For a short circuit on the channel, the output is disabled and a status flag is provided as read-only bits on page 0 / register 44, bit D7. If shutdown mode is enabled, then as soon as the short circuit is detected, page 0, register 9, bit D5 (for HPOUT) clears automatically. Next, the device requires a reset to re-enable the output stage. Resetting can be done in two ways. First, the device master reset can be used, which requires either toggling the  $\overline{RST}$  pin or using the software reset. If master reset is used, it resets all of the registers. Second, a dedicated headphone power-stage reset can also be used to re-enable the output stage, and that keeps all of the other device settings. The headphone power stage reset is done by setting page 1, register 9, bit D5 for HPOUT. If the fault condition has been removed, then the device returns to normal operation. If the fault is still present, then another shutdown occurs. Repeated resetting (more than three times) is not recommended, as this could lead to overheating.

### 3.4.8.2 Speaker Driver

The TAS2505 has an integrated class-D mono speaker driver (SPKP/SPKM) capable of driving an 8- $\Omega$  or 4- $\Omega$  differential load. The speaker driver can be powered directly from the battery supply (2.7 V to 5.5 V) on the

SPKVDD pins; however, the voltage (including spike voltage) must be limited below the absolute-maximum voltage of 6 V.

The speaker driver is capable of supplying 800 mW per channel with a 3.6-V power supply. Through the use of digital mixing, the device can connect one or both digital audio playback data channels to either speaker driver; this also allows digital channel swapping if needed.

The class-D speaker driver can be powered on by writing to page 1, register 45, bit D1. The class-D output-driver gain can be controlled by writing to page 1, register 48, bits D6–D4, and it can be muted by writing to page 1, register 48, bit D6 - D4 = 000.

The TAS2505 has a short-circuit protection feature for the speaker drivers that is always enabled to provide protection. If the output is shorted, the output stage shuts down on the overcurrent condition. (Current limiting is not an available option for the higher-current speaker driver output stage.) In case of a short circuit, the output is disabled and a the enable bit is reset to 0 on page 1, register 45, bit D1.

If shutdown occurs due to an overcurrent condition, then the device requires to re-enable the output stage. The speaker power-stage reset is done by setting page 1, register 45, bit D1 to 1. If the fault condition has been removed, then the device returns to normal operation. If the fault is still present, then another shutdown occurs. Repeated resetting (more than three times) is not recommended, as this could lead to overheating.

**To minimize battery current leakage, the SPKVDD voltage level should not be less than the AVDD voltage level.**

The TAS2505 has a thermal protection (OTP) feature for the speaker driver which is always enabled to provide protection. If the device is overheated, then the output stops switching. When the device cools down, the output resumes switching. An overtemperature status flag is provided as a read-only bit on page 0, register 45, bit D7. The OTP feature is for self-protection of the device. If die temperature can be controlled at the system/board level, then overtemperature does not occur.

### 3.4.9 Audio Output-Stage Power Configurations

After the device has been configured (following a  $\overline{RST}$ ) and the circuitry has been powered up, the audio output stage can be powered up and powered down by register control.

These functions soft-start automatically. By using these register controls, it is possible to turn all four stages on at the same time without turning two of them off.

See [Table 3-11](#) for register control of audio output stage power configurations.

**Table 3-11. Audio Output Stage Power Configurations**

Audio Output Pins	Desired Function	Page 1 / Register, Bit Value
HPOUT	Power-down HPOUT driver	Page 1 / register 9, bit D5 = 0
HPOUT	Power-up HPOUT driver	Page 1 / register 8, bit D5 = 1
SPKP / SPKM	Power-down class-D driver	Page 1 / register 45, bit D1 = 0
SPKP / SPKM	Power-up class-D driver	Page 1 / register 45, bit D1 = 1

### 3.4.10 5V LDO

The TAS2505 has a built-in LDO which can generate the analog supply (AVDD) also the digital supply (DVDD) from input voltage range of 2.7 V to 5.5 V with high PSRR. If combined power supply current is 50 mA or less, then this LDO can deliver power to both analog and digital power supplies. If the only speaker power supply is present and LDO Select pin is enabled, the LDO can power up without requiring other supplies. This LDO requires a minimum dropout voltage of 300 mV and can support load currents up to 50 mA. For stability reasons the LDO requires a minimum decoupling capacitor of 1  $\mu$ F ( $\pm$ 50%) on the analog supply (AVDD) pin and the digital supply (DVDD) pin. If use this LDO output voltage for the digital supply (DVDD) pin, the analog supply (AVDD) pin connected to the digital supply (DVDD) externally is required.

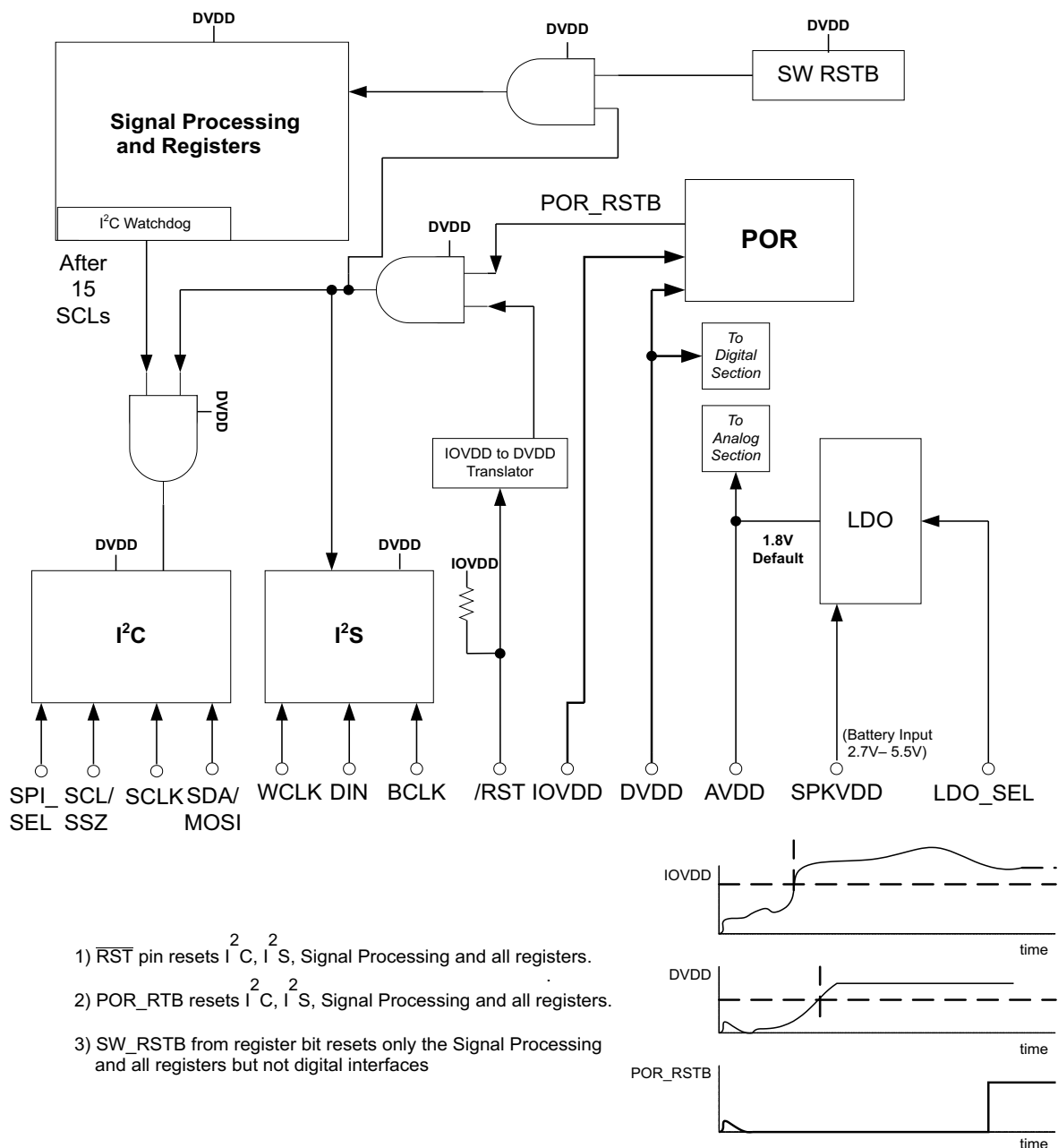
The LDO is by default powered down for low sleep mode currents and can be enabled driving the LDO\_SEL pin to SPKVDD (Speaker power supply). When the LDO is disabled the AVDD pin is tri-stated and the device AVDD needs to be powered using external supply. In that case the DVDD pin is also tri-stated and the device DVDD needs to be powered using external supply. The output voltage of this LDO can be adjusted to a few different values as given in the [Table 3-12](#). A Circuit Configuration with Internal LDO is shown in [Section 2.2](#)

**Table 3-12. AVDD LDO Settings**

Page-1, Register 2, D(5:4)	LDO Output
00	1.8 V
01	1.6 V
10	1.7 V
11	1.5 V

### 3.4.11 POR

TAS2505 has a POR (Power On Reset) function as shown Figure 3-7. This function insures that all registers are automatically set to defaults when a proper power up sequence is executed. The function consume approximately 35uA from the DVDD so if needed this can be disabled by page 1, register 1, bit D3 = 1.



**Figure 3-7. POR Diagram**

### 3.4.12 DAC Setup

The following paragraphs are intended to guide a user through the steps necessary to configure the TAS2505.

#### Step 1

The system clock source (master clock) and the targeted DAC sampling frequency must be identified. Depending on the targeted performance, the decimation filter type (A or B) and DOSR value can be determined:

- Filter A should be used for 48-kHz high-performance operation; DOSR must be a multiple of 8.
- Filter B should be used for up to 96-kHz operations; DOSR must be a multiple of 4.

In all cases, DOSR is limited in its range by the following condition:

$$2.8 \text{ MHz} < \text{DOSR} \times \text{DAC\_fs} < 6.2 \text{ MHz} \quad (3)$$

Based on the identified filter type and the required signal processing capabilities, the appropriate processing block can be determined from the list of available processing blocks (PRB\_P1, PRB\_P2 and PRB\_P3).

Based on the available master clock, the chosen DOSR and the targeted sampling rate, the clock divider values NDAC and MDAC can be determined. If necessary, the internal PLL can add a large degree of flexibility.

In summary, CODEC\_CLKIN (derived directly from the system clock source or from the internal PLL) divided by MDAC, NDAC, and DOSR must be equal to the DAC sampling rate DAC\_fs. The CODEC\_CLKIN clock signal is shared with the DAC clock generation block.

$$\text{CODEC\_CLKIN} = \text{NDAC} \times \text{MDAC} \times \text{DOSR} \times \text{DAC\_fs} \quad (4)$$

NDAC and MDAC can be chosen independently in the range of 1 to 128. In general, NDAC should be as large as possible as long as the following condition can still be met:

$$\text{MDAC} \times \text{DOSR} / 32 \geq \text{RC} \quad (5)$$

RC is a function of the chosen processing block and is listed in [Table 3-3](#).

The common-mode voltage setting of the device is determined by the available analog power supply. This common-mode (input common-mode) value is common across the ADC, DAC and analog bypass path. The output common-mode setting is determined by the available analog power supplies (AVdd) and the desired output-signal swing.

At this point, the following device specific parameters are known:

PRB\_Rx, DOSR, NDAC, MDAC, input and output common-mode values.

If the PLL is used, the PLL parameters P, J, D and R are determined as well.

#### Step 2

Setting up the device with register programming:

The following list gives a sequence of items that must be executed in the time between powering the device up and reading data from the device:

1. Define starting point:
  - a. Power up applicable external power supplies
  - b. Set register page to 0
  - c. Initiate SW reset
2. Program Clock Settings
  - a. Program PLL clock dividers P, J, D and R (if PLL is necessary)
  - b. Power up PLL (if PLL is necessary)
  - c. Program and power up NDAC
  - d. Program and power up MDAC

- e. Program OSR value
- f. Program I2S word length if required (16, 20, 24, or 32 bits)
- g. Program the processing block to be used
- h. Miscellaneous page 0 controls

At this point, at the latest, the analog power supply must be applied to the device

3. Program Analog Blocks
  - a. Set register page to 1
  - b. Disable coarse AVDD generation
  - c. Enable Master Analog Power Control
  - d. Program common-mode voltage
  - e. Program headphone-specific de-pop settings (if a headphone driver is used)
  - f. Program routing of DAC output to the output amplifier (headphone and lineout or speaker)
4. Apply waiting time determined by the de-pop settings and the soft-stepping settings of the driver gain or poll page 1, register 63
5. Power up DAC
  - a. Set register page to 0
  - b. Power up DAC channels and set digital gain
  - c. Unmute digital volume control
6. Power up Output Drivers
  - a. Unmute and set gain of output drivers
  - b. Power up output drivers

Detailed examples can be found from [Section 5.1](#) to [Section 5.6](#).

### 3.5 PowerTune

The TAS2505 features PowerTune, a mechanism to balance power-versus-performance tradeoffs at the time of device configuration. The device can be tuned to minimize power dissipation, to maximize performance, or to an operating point between the two extremes to best fit the application.

#### 3.5.1 PowerTune Modes

##### 3.5.1.1 DAC - Programming PTM\_P1 to PTM\_P4

On the playback side, the performance is determined by a combination of register settings and the audio data word length applied. For the highest performance setting (PTM\_P4), an audio-data word length of 20 bits is required, while for the modes PTM\_P1 to PTM\_P3 a word length of 16 bits is sufficient.

	PTM_P1	PTM_P2	PTM_P3	PTM_P4
Pg 1, Reg 3, D(4:2)	0x2	0x1	0x0	0x0
Audio Data word length Pg 0, Reg 27, D(5:4)	16 bits 0x00	16 bits 0x00	16 bits 0x00	20 or more bits 0x1, 0x2, 0x3

##### 3.5.1.2 Processing Blocks

The choice of processing blocks, PRB\_P1 to PRB\_P3 for playback, also influences the power consumption. In fact, the numerous processing blocks have been implemented to offer a choice between power-optimization and configurations with more signal-processing resources.

### 3.5.2 DAC Power Consumption

The tables in this section give recommendations for various DAC PowerTune modes. Typical performance and power-consumption numbers for line-out signals are listed.

All measurements were taken with the PLL turned off, no signal is present, and the DAC modulator is fully running. PowerTune modes which are not supported are marked with an 'X'.

#### 3.5.2.1 DAC, Mono, 48 kHz, Highest Performance, DVDD = IOVDD = 1.8 V, AVDD = 1.8 V, SPKVDD = 3.6V DOSR = 128, Processing Block = PRB\_P3 (Interpolation Filter B)

		Device Common Mode Setting = 0.75V				Device Common Mode Setting = 0.9V				Unit
		PTM_P1	PTM_P2	PTM_P3	PTM_P4	PTM_P1	PTM_P2	PTM_P3	PTM_P4	
0dB full scale <sup>(1)</sup>		75	225	375	375	100	300	500	500	mV <sub>RMS</sub>
HP out (16-Ω load)	Idle Channel Noise	16.8	16.9	17.1	17.0	19.4	20.0	20.1	20.0	μV
	Power consumption	7.2	7.4	7.7	7.7	7.3	7.7	8.0	8.1	mW

(1) Reduced 0dB full-scale swing can be compensated by applying appropriate gain in the output drivers see [Section 3.4.2.1](#).

Alternative Processing Blocks:

Processing Block	Filter	Estimated Power Change at PTM_P3		Unit
		HP out		
		CM = 0.75V	CM = 0.9V	
PRB_P1	A	+1.34	+1.30	mW
PRB_P2	A	-0.11	-0.11	

#### 3.5.2.2 DAC, Mono, Lowest Power Consumption

##### DOSR = 64, Processing Block = PRB\_P3 (Interpolation Filter B)

		CM = 0.75V AVDD = 1.5V	CM = 0.9V AVDD = 1.8V	Unit
		PTM_P1	PTM_P1	
0-dB full scale <sup>(1)</sup>		75	100	mV <sub>RMS</sub>
HP out (16-Ω load)	Idle Channel Noise	16.8	19.3	μV
	Power consumption	5.8	6.7	mW

Alternative Processing Blocks:

Processing Block	Filter	Estimated Power Change at PTM_P3		Unit
		HP out		
		CM = 0.75V	CM = 0.9V	
PRB_P1	A	+1.34	+1.30	mW
PRB_P2	A	-0.11	-0.11	

### 3.5.2.3 DAC, Mono, 8 kHz, Highest Performance, DVDD = IOVDD = 1.8 V, AVDD = 1.8 V, SPKVDD = 3.6 V

DOSR = 768, Processing Block = PRB\_P2 (Interpolation Filter A)

		Device Common Mode Setting = 0.75V				Device Common Mode Setting = 0.9V				Unit
		PTM_P1	PTM_P2	PTM_P3	PTM_P4	PTM_P1	PTM_P2	PTM_P3	PTM_P4	
0dB full scale <sup>(1)</sup>		75	225	375	375	100	300	500	500	mV <sub>RMS</sub>
HP out (16-Ω load)	Idle Channel Noise	14.3	14.3	14.5	14.4	16.7	16.8	16.9	17.3	μV
	Power consumption	5.8	6.0	6.2	6.3	5.8	6.2	6.4	6.5	mW

(1) Reduced 0dB full-scale swing can be compensated by applying appropriate gain in the output drivers see [Section 3.4.2.1](#).

Alternative Processing Blocks:

Processing Block	Filter	Estimated Power Change at PTM_P1		Unit
		HP out		
		CM = 0.75V	CM = 0.9V	
PRB_P1	A	+0.46	+0.53	mW
PRB_P3	B	+0.19	+0.26	

### 3.5.2.4 DAC, Mono, Lowest Power Consumption

DOSR = 384, Processing Block = PRB\_P2 (Interpolation Filter A)

		CM = 0.75V AVDD = 1.5V	CM = 0.9V AVDD = 1.8V	Unit
		PTM_P1	PTM_P1	
0dB full scale <sup>(1)</sup>		75	100	mV <sub>RMS</sub>
HP out (16-Ω load)	Idle Channel Noise	14.2	16.9	μV
	Power consumption	4.2	5.1	mW

Alternative Processing Blocks:

Processing Block	Filter	Estimated Power Change at PTM_P1		Unit
		HP out		
		CM = 0.75V	CM = 0.9V	
PRB_P1	A	+0.43	+0.43	mW
PRB_P3	B	+0.17	+0.18	

### 3.5.3 Speaker output Power Consumption

To consider Speaker output power consumption on the TAS2505, the tables in this section to be may useful to know the power consumption for each power rail. The tables shows selected as representable combination of PRB mode and PTM mode.

All measurements were taken with the PLL turned off, no signal is present, and the DAC modulator is fully running.

#### 3.5.3.1 Speaker output, Mono, 48 kHz, Highest Performance, DVDD = IOVDD = 1.8 V, AVDD = 1.8 V, SPKVDD = 3.6V

**DOSR = 128, PRB mode = PRB\_P3, PTM mode = PTM\_P3, CM = 0.9V**

		iSVDD	iAVDD	iDVDD	iIOVDD	Total	
SPK Driver (4-Ω load)	Power consumption	28.51	3.26	3.71	0.01	35.5	mW

#### 3.5.3.2 Speaker output, Mono, Lowest Power Consumption

**DOSR = 64, PRB mode = PRB\_P3, PTM mode = PTM\_P3, CM = 0.9V**

		iSVDD	iAVDD	iDVDD	iIOVDD	Total	
SPK Driver (4-Ω load)	Power consumption	28.50	3.26	3.01	0.01	34.8	mW

#### 3.5.3.3 Speaker output, Mono, 8 kHz, Highest Performance, DVDD = IOVDD = 1.8 V, AVDD = 1.8 V, SPKVDD = 3.6V

**DOSR = 768, PRB mode = PRB\_P2, PTM mode = PTM\_P3, CM = 0.9V**

		iSVDD	iAVDD	iDVDD	iIOVDD	Total	
SPK Driver (4-Ω load)	Power consumption	28.49	3.26	2.23	0.01	34.0	mW

#### 3.5.3.4 Speaker output, Mono, Lowest Power Consumption

**DOSR = 384, PRB mode = PRB\_P2, PTM mode = PTM\_P3, CM = 0.9V**

		iSVDD	iAVDD	iDVDD	iIOVDD	Total	
SPK Driver (4-Ω load)	Power consumption	28.49	3.26	1.53	0.01	33.3	mW

### 3.5.4 Headphone output Power Consumption

To consider Headphone output power consumption on the TAS2505, the tables in this section to be may useful to know the power consumption for each power rail. The tables shows selected as representable combination of PRB mode and PTM mode.

All measurements were taken with the PLL turned off, no signal is present, and the DAC modulator is fully running.

#### 3.5.4.1 Headphone output, Mono, 48 kHz, Highest Performance, DVDD = IOVDD = 1.8 V, AVDD = 1.8 V, SPKVDD = 3.6V

**DOSR = 128, PRB mode = PRB\_P3, PTM mode = PTM\_P3, CM = 0.9V**

		iSVDD	iAVDD	iDVDD	iIOVDD	Total	
Headphone Driver (16-Ω load)	Power consumption	0.11	4.50	3.42	0.01	8.0	mW

#### 3.5.4.2 Headphone output, Mono, Lowest Power Consumption, DVDD = IOVDD = 1.8 V, AVDD = 1.5 V, SPKVDD = 3.6V

**DOSR = 64, PRB mode = PRB\_P3, PTM mode = PTM\_P1, CM = 0.75V**

		iSVDD	iAVDD	iDVDD	iIOVDD	Total	
Headphone Driver (16-Ω load)	Power consumption	0.12	2.97	2.68	0.01	5.8	mW

#### 3.5.4.3 Headphone output, Mono, 8 kHz, Highest Performance, DVDD = IOVDD = 1.8 V, AVDD = 1.8 V, SPKVDD = 3.6V

**DOSR = 768, PRB mode = PRB\_P2, PTM mode = PTM\_P3, CM = 0.9V**

		iSVDD	iAVDD	iDVDD	iIOVDD	Total	
Headphone Driver (16-Ω load)	Power consumption	0.13	4.43	1.82	0.01	6.4	mW

#### 3.5.4.4 Headphone output, Mono, Lowest Power Consumption, DVDD = IOVDD = 1.8 V, AVDD = 1.8 V, SPKVDD = 3.6V

**DOSR = 384, PRB mode = PRB\_P2, PTM mode = PTM\_P1, CM = 0.75V**

		iSVDD	iAVDD	iDVDD	iIOVDD	Total	
Headphone Driver (16-Ω load)	Power consumption	0.12	2.96	1.11	0.01	4.2	mW

### 3.6 CLOCK Generation and PLL

The TAS2505 supports a wide range of options for generating clocks for the DAC sections as well as interface and other control blocks as shown in . The clocks for the DAC require a source reference clock. This clock can be provided on a variety of device pins, such as the MCLK, BCLK, or GPIO pins. The source reference clock for the codec can be chosen by programming the CODEC\_CLKIN value on page 0, register 4, bits D1–D0. The CODEC\_CLKIN can then be routed through highly-flexible clock dividers shown in to generate the various clocks required for the DAC and the Digital Effects section. In the event that the desired audio clocks cannot be generated from the reference clocks on MCLK, BCLK, or GPIO, the TAS2505 also provides the option of using the on-chip PLL which supports a wide range of fractional multiplication values to generate the required clocks. Starting from CODEC\_CLKIN, the TAS2505 provides several programmable clock dividers to help achieve a variety of sampling rates for the DAC and clocks for the Digital Effects sections.

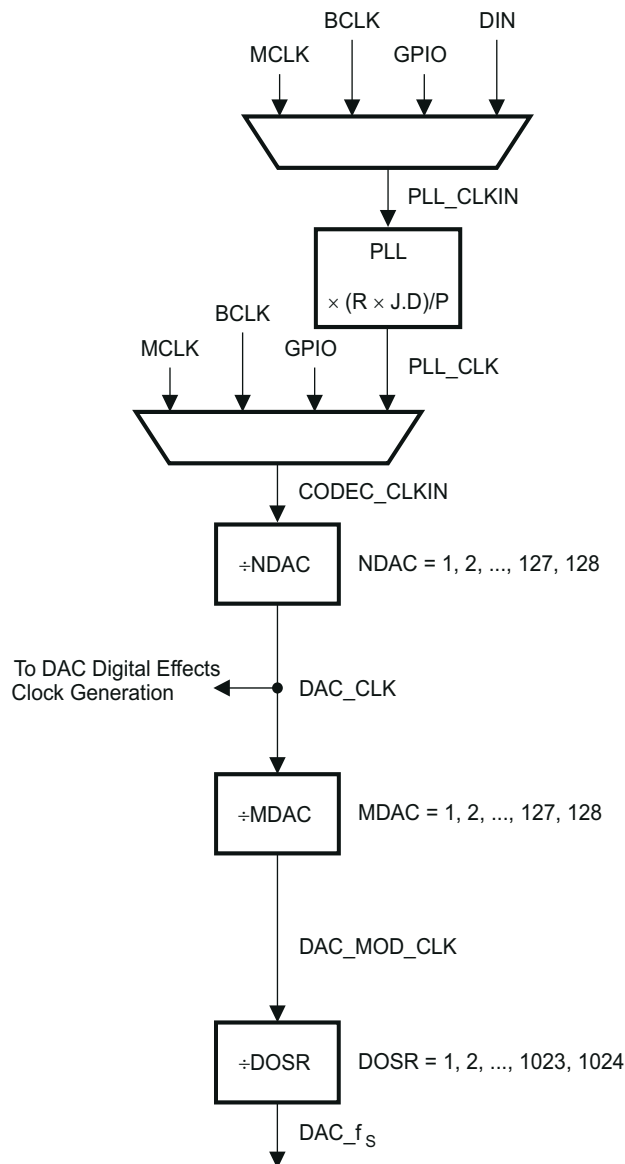


Figure 3-8. Clock Distribution Tree

$$\text{DAC\_MOD\_CLK} = \frac{\text{CODEC\_CLKIN}}{\text{NDAC} \times \text{MDAC}}$$

$$\text{DAC\_f}_s = \frac{\text{CODEC\_CLKIN}}{\text{NDAC} \times \text{MDAC} \times \text{DOSR}} \quad (6)$$

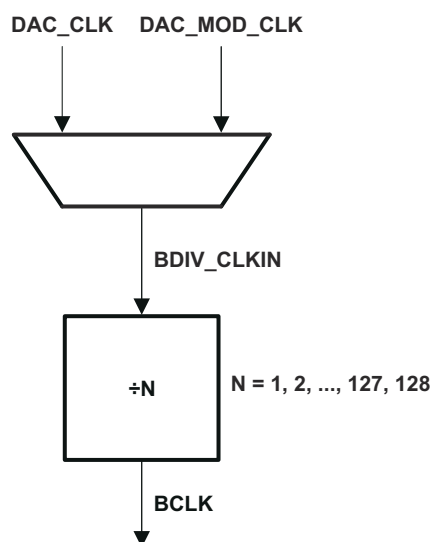
**Table 3-13. CODEC CLKIN Clock Dividers**

Divider	Bits
NDAC	Page 0, register 11, bits D6–D0
MDAC	Page 0, register 12, bits D6–D0
DOSR	Page 0, register 13, bits D1–D0 and page 0, register 14, bits D7–D0

The DAC modulator is clocked by DAC\_MOD\_CLK. For proper power-up operation of the DAC channel, these clocks must be enabled by configuring the NDAC and MDAC clock dividers (page 0, register 11, bit D7 = 1 and page 0, register 12, bit D7 = 1). When the DAC channel is powered down, the device internally initiates a power-down sequence for proper shut-down. During this shutdown sequence, the NDAC and MDAC dividers must not be powered down, or else a proper low-power shutdown may not take place. The user can read back the power-status flag at page 0, register 37, bit D7 and page 0, register 37, bit D3. When both the flags indicate power-down, the MDAC divider may be powered down, followed by the NDAC divider.

In general, all the root clock dividers should be powered down only after the child clock dividers have been powered down for proper operation.

The TAS2505 also has options for routing some of the internal clocks to the GPIO output pin to be used as general-purpose clocks in the system. The feature is shown in [Figure 3-10](#).



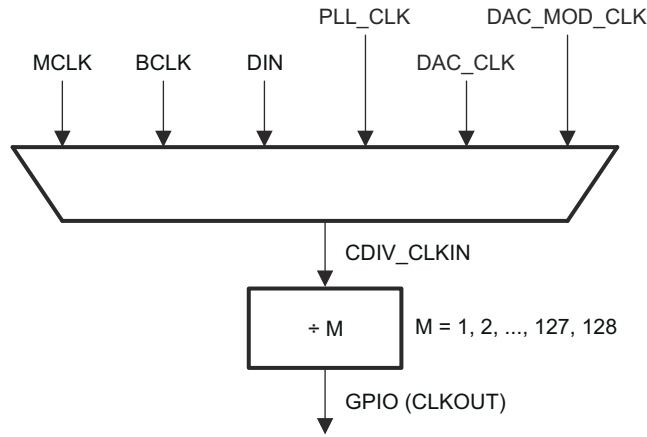
B0362-01

**Figure 3-9. BCLK Output Options**

In the mode when TAS2505 is configured to drive the BCLK pin (page 0, register 27, bit D3 = 1), it can be driven as a divided value of BDIV\_CLKIN. The division value can be programmed in page 0, register 30, bits D6–D0 from 1 to 128 (see [Figure 3-9](#)). The BDIV\_CLKIN can itself be configured to be one of DAC\_CLK (DAC DSP clock) or DAC\_MOD\_CLK by configuring the BDIV\_CLKIN multiplexer in page 0, register 29, bits D1–D0. Additionally, a general-purpose clock can be driven out on GPIO.

This clock can be a divided-down version of CDIV\_CLKIN. The value of this clock divider can be programmed from 1 to 128 by writing to page 0, register 26, bits D6–D0. The CDIV\_CLKIN can itself be programmed as one

of the clocks among the list shown in Figure 3-10. This can be controlled by programming the multiplexer in page 0, register 25, bits D2–D0.



B0363-01

Figure 3-10. General-Purpose Clock Output Options

Table 3-14. Maximum TAS2505 Clock Frequencies

Clock	DVDD ≥ 1.65 V
CODEC_CLKIN	≤ 110 MHz
DAC_CLK	≤ 49.152 MHz
DAC_MOD_CLK	6.758 MHz
DAC <sub>f<sub>s</sub></sub>	0.192 MHz
BDIV_CLKIN	55 MHz
CDIV_CLKIN	100 MHz when M is odd 110 MHz when M is even

### 3.6.1 PLL

For lower power consumption, it is best to derive the internal audio processing clocks using the simple dividers. When the input MCLK or other source clock is not an integer multiple of the audio processing clocks, then it is necessary to use the on-board PLL. The TAS2505 fractional PLL can be used to generate an internal master clock used to produce the processing clocks needed by the DAC and Digital Effects. The programmability of this PLL allows operation from a wide variety of clocks that may be available in the system.

The PLL input supports clocks varying from 512 kHz to 20 MHz and is register programmable to enable generation of required sampling rates with fine resolution. The PLL can be turned on by writing to page 0 / register 5, bit D7. When the PLL is enabled, the PLL output clock PLL\_CLK is given by the following equation:

$$PLL\_CLK = \frac{PLL\_CLKIN \times R \times JD}{P} \quad (7)$$

where

R = 1, 2, 3, ..., 16 (page 0 / register 5, default value = 1)

J = 1, 2, 3, ..., 63, (page 0 / register 6, default value = 4)

D = 0, 1, 2, ..., 9999 (page 0 / register 7 and 8, default value = 0)

P = 1, 2, 3, ..., 8 (page 0 / register 5, default value = 1)

The PLL can be turned on via page 0, register 5, bit D7. The variable P can be programmed via page 0, register 5, bits D6–D4. The variable R can be programmed via page 0, register 5, bits D3–D0. The variable

J can be programmed via page 0, register 6, bits D5–D0. The variable D is 14 bits and is programmed into two registers. The MSB portion can be programmed via page 0, register 7, bits D5–D0, and the LSB portion is programmed via page 0, register 8, bits D7–D0. For proper update of the D-divider value, page 0, register 7 must be programmed first, followed immediately by page 0, register 8. Unless the write to page 0, register 8 is completed, the new value of D does not take effect.

When the PLL is enabled, the following conditions must be satisfied.

- When the PLL is enabled and D = 0, the following conditions must be satisfied for PLL\_CLKIN:

$$512 \text{ kHz} \leq \frac{\text{PLL\_CLKIN}}{P} \leq 20 \text{ MHz} \quad (8)$$

$$80 \text{ MHz} \leq (\text{PLL\_CLKIN} \times J.D \times R/P) \leq 110 \text{ MHz}$$

$$4 \leq R \times J \leq 259 \quad (9)$$

- When the PLL is enabled and D ≠ 0, the following conditions must be satisfied for PLL\_CLKIN:

$$10 \text{ MHz} \leq \frac{\text{PLL\_CLKIN}}{P} \leq 20 \text{ MHz} \quad (10)$$

$$80 \text{ MHz} \leq (\text{PLL\_CLKIN} \times J.D \times R/P) \leq 110 \text{ MHz} \quad (11)$$

$$R = 1 \quad (12)$$

### 3.6.1.1 PLL Description

In the TAS2505, the PLL\_CLK supports a wide range of output clock, based on register settings and power-supply conditions.

**Table 3-15. PLL\_CLK Frequency Range**

AVDD	PLL Mode Page 0, Reg 4, D6	Min PLL_CLK frequency (MHz)	Max PLL_CLK frequency (MHz)
≥1.5V	0	75	110
	1	90	119
≥1.65V	0	75	130
	1	90	130
≥1.80V	0	75	140
	1	90	150

The PLL can be powered up independently from the ADC and DAC blocks, and can also be used as a general purpose PLL by routing its output to the GPIO output. After powering up the PLL, PLL\_CLK is available typically after 10ms. The PLL output frequency is controlled by J.D and R dividers

PLL Divider	Bits
J	Page 0, Register 6, D(5:0)
D	Page 0, Register 7, D(5:0) and Page 0, Register 8, D(7:0)
R	Page 0, Register 5, D(3:0)

The D-divider value is 14-bits wide and is controlled by 2 registers. For proper update of the D-divider value, Page 0, Register 7 must be programmed first followed immediately by Page 0, Register 8. Unless the write to Page 0, Register 8 is completed, the new value of D will not take effect

The clocks for codec and various signal processing blocks, CODEC\_CLKIN can be generated from MCLK input, BCLK input, GPIO input or PLL\_CLK (Page 0, Register 4, Bit D1 to D0).

If the CODEC\_CLKIN is derived from the PLL, then the PLL must be powered up first and powered down last.

**Table 3-16. PLL Example Configurations**

PLL_CLKIN (MHz)	PLL P	PLL R	PLL J	PLL D	MDAC	NDAC	DOSR
<b><math>f_s = 44.1</math> kHz</b>							
2.8224	1	3	10	0	3	5	128
5.6448	1	3	5	0	3	5	128
12	1	1	7	560	3	5	128
13	1	1	6	3504	6	3	104
16	1	1	5	2920	3	5	128
19.2	1	1	4	4100	3	5	128
48	4	1	7	560	3	5	128
<b><math>f_s = 48</math> kHz</b>							
2.048	1	3	14	0	7	2	128
3.072	1	4	7	0	7	2	128
4.096	1	3	7	0	7	2	128
6.144	1	2	7	0	7	2	128
8.192	1	4	3	0	4	4	128
12	1	1	7	1680	7	2	128
16	1	1	5	3760	7	2	128
19.2	1	1	4	4800	7	2	128
48	4	1	7	1680	7	2	128

## 3.7 Digital Audio and Control Interface

### 3.7.1 Digital Audio Interface

Audio data is transferred between the host processor and the TAS2505 via the digital audio data serial interface, or audio bus. The audio bus on this device is flexible, including left- or right-justified data options, support for I<sup>2</sup>S or PCM protocols, programmable data-length options, a TDM mode for multichannel operation, flexible master/slave configurability for each bus clock line, and the ability to communicate with multiple devices within a system directly.

The audio bus of the TAS2505 can be configured for left- or right-justified, I<sup>2</sup>S, DSP, or TDM modes of operation, where communication with standard telephony PCM interfaces is supported within the TDM mode. These modes are all MSB-first, with data width programmable as 16, 20, 24, or 32 bits by configuring page 0, register 27, bits D5–D4. In addition, the word clock and bit clock can be independently configured in either master or slave mode for flexible connectivity to a wide variety of processors. The word clock is used to define the beginning of a frame, and may be programmed as either a pulse or a square-wave signal. The frequency of this clock corresponds to the maximum of the selected DAC sampling frequencies.

The bit clock is used to clock in and clock out the digital audio data across the serial bus. When in master mode, this signal can be programmed to generate variable clock pulses by controlling the bit-clock divider in page 0, register 30 (see ). The number of bit-clock pulses in a frame may need adjustment to accommodate various word lengths as well as to support the case when multiple TAS2505 may share the same audio bus.

The TAS2505 also includes a feature to offset the position of start of data transfer with respect to the word clock. This offset can be controlled in terms of number of bit clocks and can be programmed in page 0, register 28.

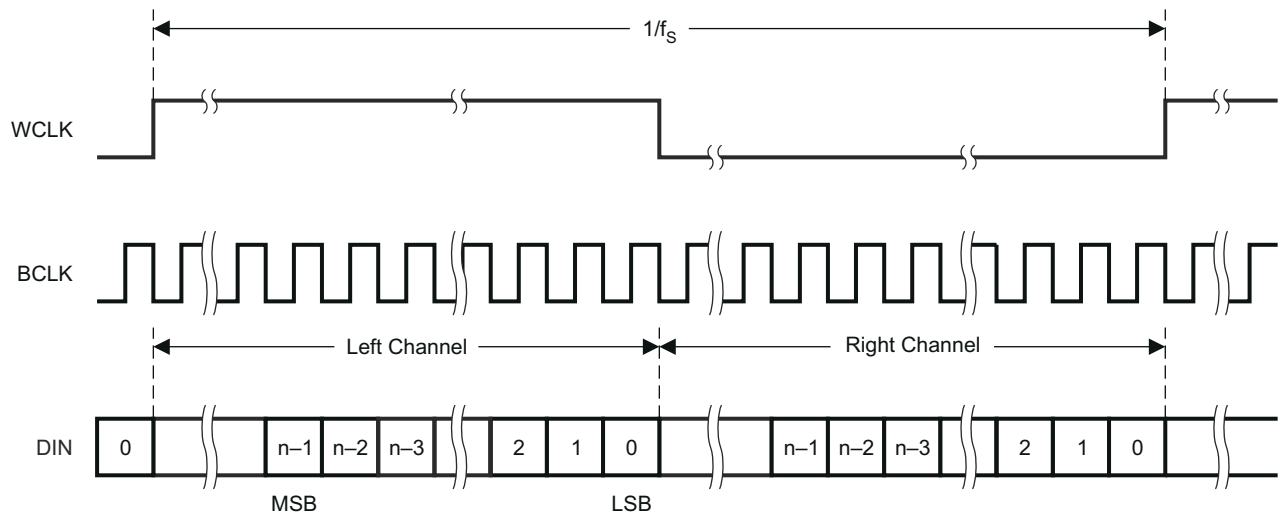
The TAS2505 also has the feature of inverting the polarity of the bit clock used for transferring the audio data as compared to the default clock polarity used. This feature can be used independently of the mode of audio interface chosen. This can be configured via page 0, register 29, bit D3.

By default, when the word clocks and bit clocks are generated by the TAS2505, these clocks are active only when the DAC is powered up within the device. This is done to save power. However, it also supports a feature

when both the word clocks and bit clocks can be active even when the codec in the device is powered down. This is useful when using the TDM mode with multiple codecs on the same bus, or when word clocks or bit clocks are used in the system as general-purpose clocks.

### 3.7.1.1 Right-Justified Mode

The audio interface of the TAS2505 can be put into right-justified mode by programming page 0, register 27, bits D7–D6 = 10. In right-justified mode, the LSB of the left channel is valid on the rising edge of the bit clock preceding the falling edge of the word clock. Similarly, the LSB of the right channel is valid on the rising edge of the bit clock preceding the rising edge of the word clock.



T0149-05

**Figure 3-11. Timing Diagram for Right-Justified Mode**

For right-justified mode, the number of bit clocks per frame should be greater than or equal to twice the programmed word length of the data.

### 3.7.1.2 Left-Justified Mode

The audio interface of the TAS2505 can be put into left-justified mode by programming page 0, register 27, bits D7–D6 = 11. In left-justified mode, the MSB of the right channel is valid on the rising edge of the bit clock following the falling edge of the word clock. Similarly, the MSB of the left channel is valid on the rising edge of the bit clock following the rising edge of the word clock.

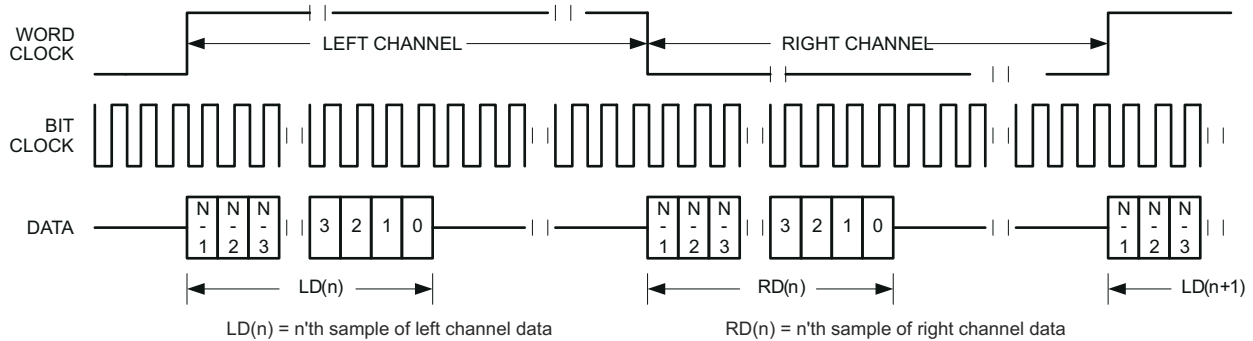


Figure 3-12. Timing Diagram for Left-Justified Mode

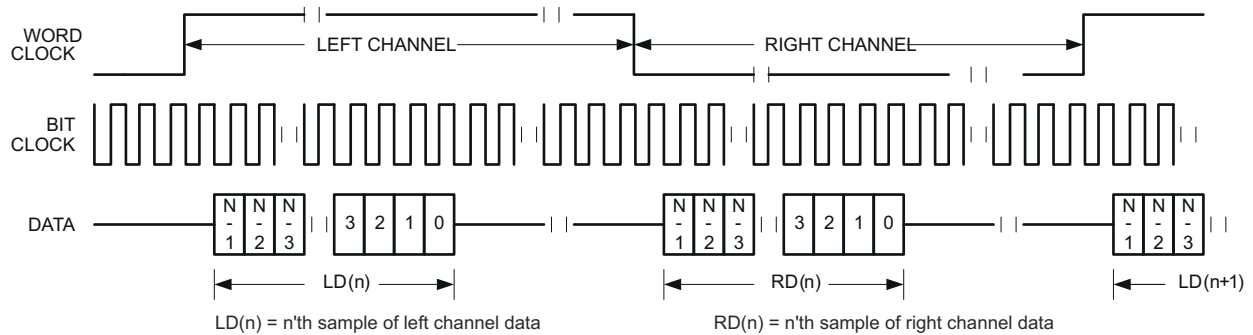


Figure 3-13. Timing Diagram for Left-Justified Mode With Offset = 1

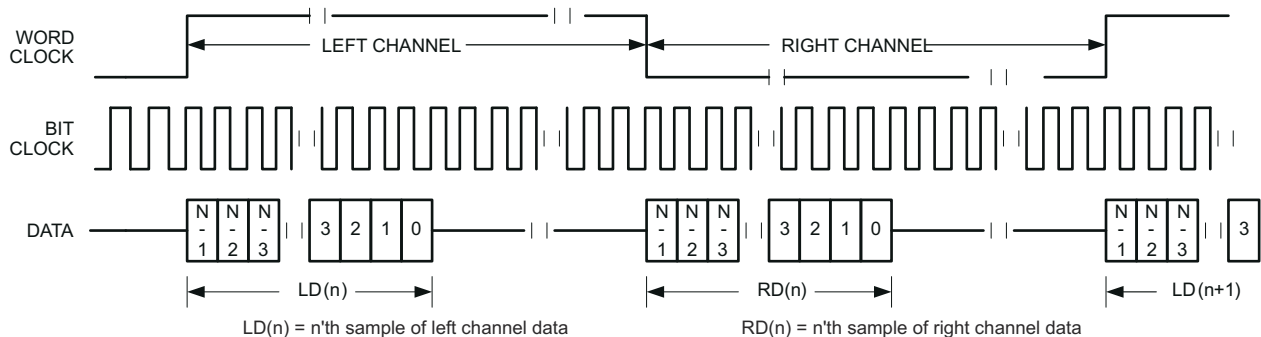


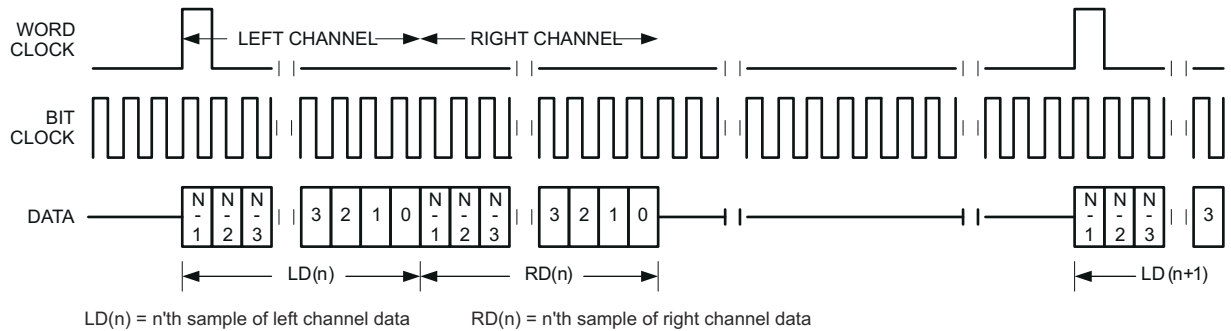
Figure 3-14. Timing Diagram for Left-Justified Mode With Offset = 0 and Inverted Bit Clock

For left-justified mode, the number of bit clocks per frame should be greater than or equal to twice the programmed word length of the data. Also, the programmed offset value should be less than the number of bit clocks per frame by at least the programmed word length of the data.

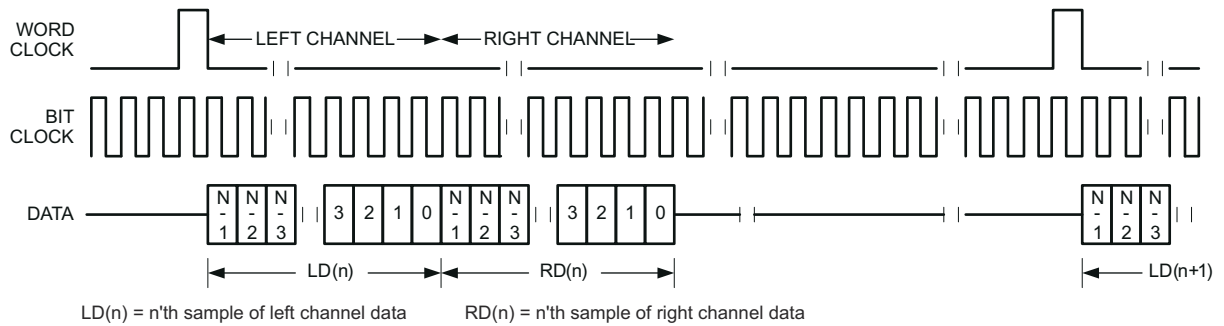
#### 3.7.1.3 I<sup>2</sup>S Mode

The audio interface of the TAS2505 can be put into I<sup>2</sup>S mode by programming page 0, register 27, bits D7–D6 = to 00. In I<sup>2</sup>S mode, the MSB of the left channel is valid on the second rising edge of the bit clock after the falling

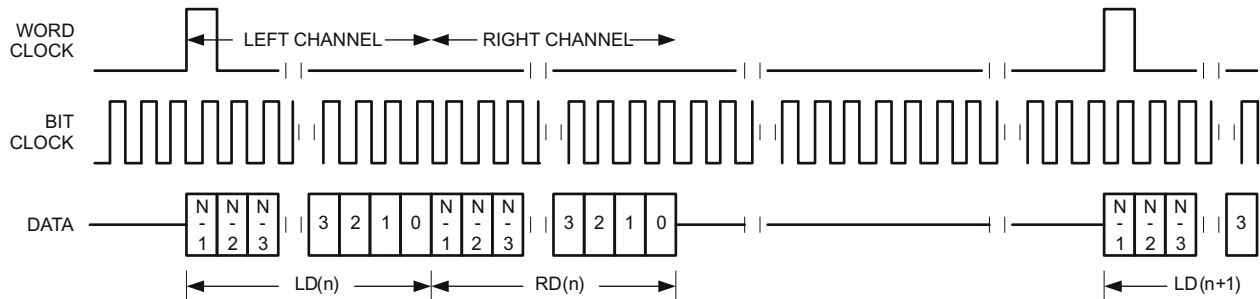




**Figure 3-18. Timing Diagram for DSP Mode**



**Figure 3-19. Timing Diagram for DSP Mode With Offset = 1**

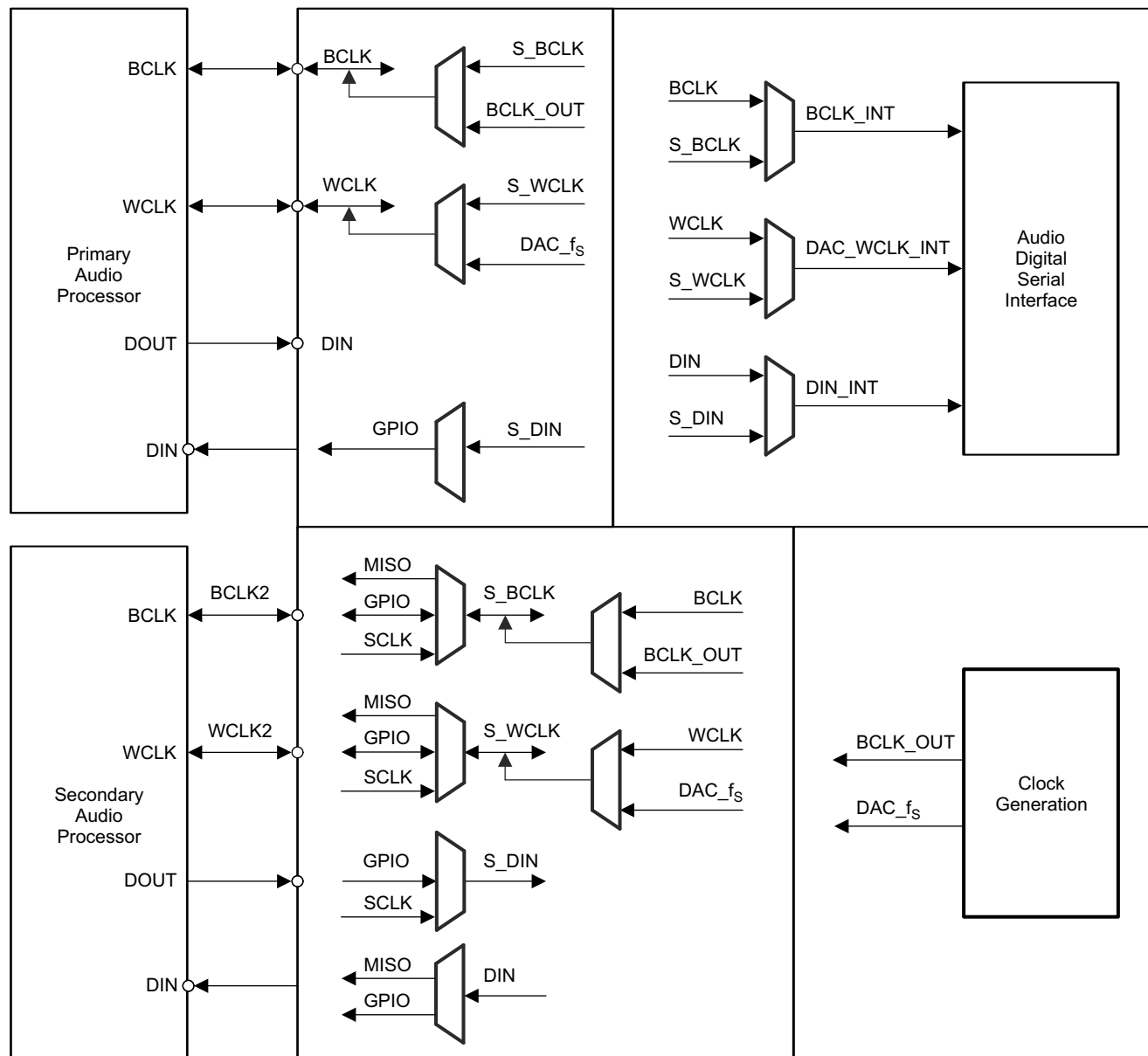


**Figure 3-20. Timing Diagram for DSP Mode With Offset = 0 and Bit Clock Inverted**

For DSP mode, the number of bit clocks per frame should be greater than or equal to twice the programmed word length of the data. Also, the programmed offset value should be less than the number of bit clocks per frame by at least the programmed word length of the data.

### 3.7.1.5 Primary and Secondary Digital Audio Interface Selection

The audio serial interface on the TAS2505 has I/O control to allow communication with two independent processors for audio data. The processors can communicate with the device one at a time. This feature is enabled by register programming of the various pin selections.



B0375-01

**Figure 3-21. Audio Serial Interface Multiplexing**

The secondary audio interface uses multifunction pins. For an overview on multifunction pins please see [Section 3.1.3 Table 3-1](#) and [Table 3-2](#) illustrates possible audio interface routing. The multifunction pins SCLK and MISO are only available in I2S communication mode. This multiplexing capability allows the TAS2505 to communicate with two separate devices with independent I2S/PCM busses, one at a time.

### 3.7.2 Control Interface

The TAS2505 control interface supports SPI or I<sup>2</sup>C communication protocols, with the protocol selectable using the SPI\_SEL pin. For SPI, SPI\_SEL should be tied high; for I<sup>2</sup>C, SPI\_SEL should be tied low. It is not recommended to change the state of SPI\_SEL during device operation.

#### 3.7.2.1 I<sup>2</sup>C Control Mode

The TAS2505 supports the I<sup>2</sup>C control protocol, and will respond to the I<sup>2</sup>C address of 0011 000. I<sup>2</sup>C is a two-wire, open-drain interface supporting multiple devices and masters on a single bus. Devices on the I<sup>2</sup>C bus only drive the bus lines LOW by connecting them to ground; they never drive the bus lines HIGH. Instead, the bus wires are pulled HIGH by pullup resistors, so the bus wires are HIGH when no device is driving them LOW. This way, two devices cannot conflict; if two devices drive the bus simultaneously, there is no driver contention.

Communication on the I<sup>2</sup>C bus always takes place between two devices, one acting as the master and the other acting as the slave. Both masters and slaves can read and write, but slaves can only do so under the direction of the master. Some I<sup>2</sup>C devices can act as masters or slaves, but the TAS2505 can only act as a slave device.

An I<sup>2</sup>C bus consists of two lines, SDA and SCL. SDA carries data, and the SCL signal provides the clock. All data is transmitted across the I<sup>2</sup>C bus in groups of eight bits. To send a bit on the I<sup>2</sup>C bus, the SDA line is driven to the appropriate level while SCL is LOW (a LOW on SDA indicates the bit is 0, while a HIGH indicates the bit is 1).

Once the SDA line has settled, the SCL line is brought HIGH, then LOW. This pulse on the SCL line clocks the SDA bit into the receiver shift register.

The I<sup>2</sup>C bus is bidirectional: the SDA line is used both for transmitting and receiving data. When a master reads from a slave, the slave drives the data line; when a master sends to a slave, the master drives the data line.

Most of the time the bus is idle, no communication is taking place, and both lines are HIGH. When communication is taking place, the bus is active. Only master devices can start communication on the bus. Normally, the data line is only allowed to change state while the clock line is LOW. If the data line changes state while the clock line is HIGH, it is either a START condition or its counterpart, a STOP condition. A START condition is when the clock line is HIGH and the data line goes from HIGH to LOW. A STOP condition is when the clock line is HIGH and the data line goes from LOW to HIGH.

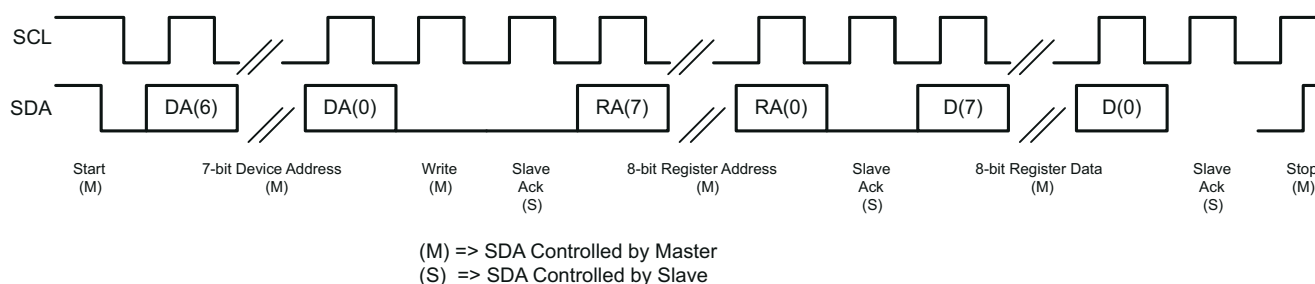
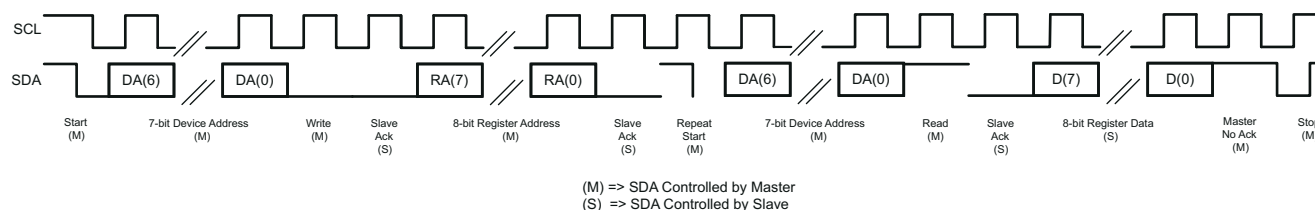
After the master issues a START condition, it sends a byte that selects the slave device for communication. This byte is called the address byte. Each device on an I<sup>2</sup>C bus has a unique 7-bit address to which it responds. (Slaves can also have 10-bit addresses; see the I<sup>2</sup>C specification for details.) The master sends an address in the address byte, together with a bit that indicates whether it wishes to read from or write to the slave device.

Every byte transmitted on the I<sup>2</sup>C bus, whether it is address or data, is acknowledged with an acknowledge bit. When a master has finished sending a byte (8 data bits) to a slave, it stops driving SDA and waits for the slave to acknowledge the byte. The slave acknowledges the byte by pulling SDA LOW. The master then sends a clock pulse to clock the acknowledge bit. Similarly, when a master has finished reading a byte, it pulls SDA LOW to acknowledge this to the slave. It then sends a clock pulse to clock the bit. (Remember that the master always drives the clock line.)

A not-acknowledge is performed by simply leaving SDA HIGH during an acknowledge cycle. If a device is not present on the bus, and the master attempts to address it, it will receive a not-acknowledge because no device is present at that address to pull the line LOW.

When a master has finished communicating with a slave, it may issue a STOP condition. When a STOP condition is issued, the bus becomes idle again. A master may also issue another START condition. When a START condition is issued while the bus is active, it is called a repeated START condition.

The TAS2505 can also respond to and acknowledge a general call, which consists of the master issuing a command with a slave address byte of 00h. This feature is disabled by default, but can be enabled via page 0, register 34, bit D5.


**Figure 3-22. I<sup>2</sup>C Write**

**Figure 3-23. I<sup>2</sup>C Read**

For a I<sup>2</sup>C register write, if the master does not issue a STOP condition, then the device enters auto-increment mode. So in the next eight clocks, the data on SDA is treated as data for the next incremental register.

Similarly, for a I<sup>2</sup>C register read, after the device has sent out the 8-bit data from the addressed register, if the master issues a ACKNOWLEDGE, the slave takes over control of SDA bus and transmit for the next 8 clocks the data of the next incremental register.

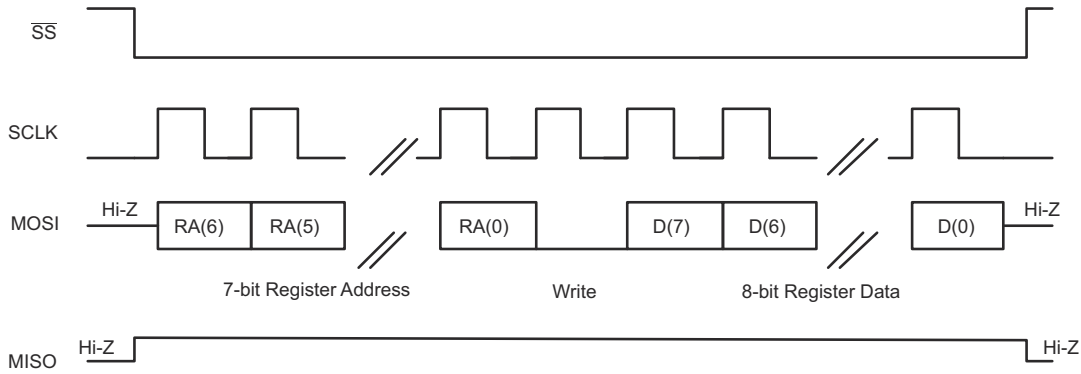
### 3.7.2.2 SPI Digital Interface

In the SPI control mode, the TAS2505 uses the pins SCL/SSZ=SSZ, SCLK=SCLK, MISO=MISO, SDA/MOSI=MOSI as a standard SPI port with clock polarity setting of 0 (typical microprocessor SPI control bit CPOL = 0). The SPI port allows full-duplex, synchronous, serial communication between a host processor (the master) and peripheral devices (slaves). The SPI master (in this case, the host processor) generates the synchronizing clock (driven onto SCLK) and initiates transmissions. The SPI slave devices (such as the TAS2505) depend on a master to start and synchronize transmissions. A transmission begins when initiated by an SPI master. The byte from the SPI master begins shifting in on the slave MOSI pin under the control of the master serial clock (driven onto SCLK). As the byte shifts in on the MOSI pin, a byte shifts out on the MISO pin to the master shift register.

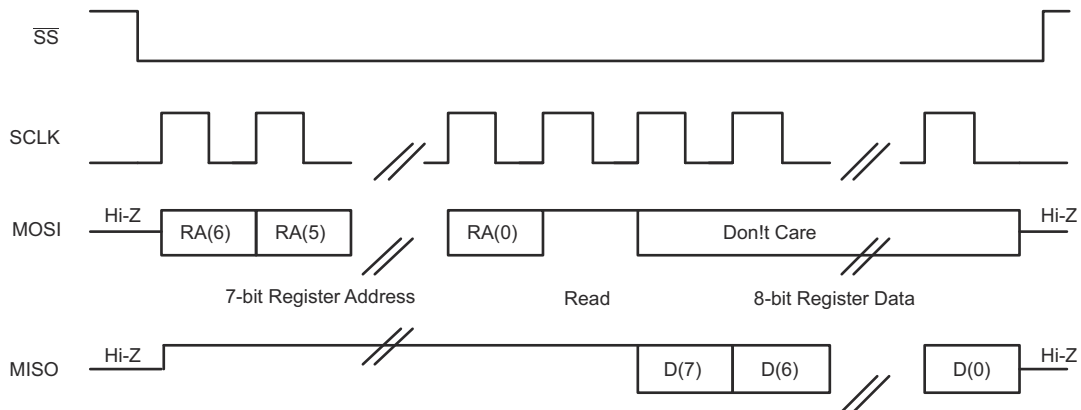
The TAS2505 interface is designed so that with a clock-phase bit setting of 1 (typical microprocessor SPI control bit CPHA = 1), the master begins driving its MOSI pin and the slave begins driving its MISO pin on the first serial clock edge. The SSZ pin can remain low between transmissions; however, the TAS2505 only interprets the first 8 bits transmitted after the falling edge of SSZ as a command byte, and the next 8 bits as a data byte only if writing to a register. Reserved register bits should be written to their default values. The TAS2505 is entirely controlled by registers. Reading and writing these registers is accomplished by an 8-bit command sent to the MOSI pin of the part prior to the data for that register. The command is structured as shown in Table 3-17. The first 7 bits specify the register address which is being written or read, from 0 to 127 (decimal). The command word ends with an R/W bit, which specifies the direction of data flow on the serial bus. In the case of a register write, the R/W bit should be set to 0. A second byte of data is sent to the MOSI pin and contains the data to be written to the register. Reading of registers is accomplished in similar fashion. The 8-bit command word sends the 7-bit register address, followed by R/W bit = 1 to signify a register read is occurring. The 8-bit register data is then clocked out of the part on the MISO pin during the second 8 SCLK clocks in the frame.

**Table 3-17. Command Word**

Bit 7	Bit 6	Bit 5	Bit 4	Bit 3	Bit 2	Bit 1	Bit 0
ADDR(6)	ADDR(5)	ADDR(4)	ADDR(3)	ADDR(2)	ADDR(1)	ADDR(0)	R/WZ



**Figure 3-24. SPI Timing Diagram for Register Write**



**Figure 3-25. SPI Timing Diagram for Register Read**

### 3.8 Power Supply

The TAS2505 integrates a large amount of digital and analog functionality, and each of these blocks can be powered separately to enable the system to select appropriate power supplies for desired performance and power consumption. The device has separate power domains for digital IO, digital core, analog core, analog input, headphone driver, and speaker drivers. If desired, all of the supplies (except for the supplies for speaker drivers, which can directly connect to the battery) can be connected together and be supplied from one source in the range of 1.65 to 1.95V. Individually, the IOVDD voltage can be supplied in the range of 1.1V to 3.6V. For improved power efficiency, the digital core power supply can range from 1.26V to 1.95V. The analog core supply can either be derived from the internal LDO accepting an SPKVDD voltage in the range of 2.7V to 5.5V, or the AVDD pin can directly be driven with a voltage in the range of 1.5V to 1.95V. The speaker driver voltages (SPKVDD) can range from 2.7V to 5.5V.

- IOVDD

The IOVDD pin supplies the digital IO cells of the device. The voltage of IOVDD can range from 1.1 to 3.6V and is determined by the digital IO voltage of the rest of the system.

- DVDD

This pin supplies the digital core of the device. Lower DVDD voltages cause lower power dissipation. If efficient switched-mode power supplies are used in the system, system power can be optimized using low DVDD voltages. The full clock range is only supported with DVDD in the range of 1.65 to 1.95V.

- AVDD

This pin supply the analog core of the device and the headphone amplifier of the device. The analog core voltage (AVDD) should be in the range of 1.5 to 1.95V for specified performance. For AVDD voltages above 1.8V, the internal common mode voltage can be set to 0.9V (Page 1, Register 10, D6 = 0, default) resulting

in 500mVrms full-scale voltage internally. For analog voltages below 1.8V, the internal common mode voltage should be set to 0.75V (Page 1, Register 10, D6 = 1), resulting in 375mVrms internal full scale voltage.

---

#### Note

At powerup, PLL and HP Level Shifters powered down to save leakage current issue when DVDD is powered up and AVDD is powered down. This powered down must be powered up by writing Page 1, Reg 2, D3 = 0 at the time AVDD is applied, either from internal LDO or through external LDO.

---

- **SPKVDD**

This pin supply the Class-D speaker driver of the device. The speaker supply voltages should be in the range of 2.7 to 5.5V for specified performance. This pin also can be an input supply for the internal LDO. More detail on the internal LDO, please refer to [Section 3.4.10](#). Note that, even if the integrated speaker drivers are not utilized on the device, these supplies should still be connected (typically to battery voltage) and at a greater or equal voltage to all the other power supplies.

### 3.8.1 System Level Considerations

While there is flexibility in supplying the device through multiple options of power supplies, care must be taken to stay within safe areas when going to standby and shutdown modes. In summary, the lowest shutdown current is achieved when all supplies to the device are turned off, implying that all settings must be reapplied to the device after bringing the power back up. In order to retain settings in the device, the SPKVDD, the DVDD voltage and either internally or externally the AVDD voltage also must be maintained.

#### 3.8.1.1 All Supplies from Single Voltage Rail with using the internal LDO (2.75V to 5.5V)

The device can be powered directly from a single of from 2.75V to 5.5V rail through the SPKVDD (Speaker power supply) pin. During operation the AVDD LDO is activated via the LDO\_SEL pin to connect the SPKVDD pin. Also in this case, the AVDD pin as the LDO output must be connected to the DVDD pin externally.

##### 3.8.1.1.1 Standby Mode

To put the device in standby mode, the LDO bandgap (Page 1, Register 1, D1 = 0) must stay on, and all other blocks powered down. This state results in a standby current of approximately 100uA from the SPKVDD supply at 5V. In standby mode, the device responds quickly to playback requests.

##### 3.8.1.1.2 Shutdown Mode

To shut down the device, the external supply as the SPKVDD supply can be turned off completely.

#### 3.8.1.2 Supply from Dual Voltage Rails (2.75V to 5.5V and 1.8V)

If a single 1.8V rail is used for the AVDD supply and the DVDD supply, generating the 1.8V from a higher battery voltage via a DC-DC converter results in good system-level efficiency. The 1.8V rail connected to the DVDD pin can also be connected to the AVDD pin. The device operates with this connection, but the achievable performance is a function of the voltage ripple typically found on DCDC converter outputs. To achieve specified performance, an external low-input-voltage 1.6V LDO must be connected between the 1.8V rail and the AVDD input. During operation, the LDO is deactivated via the LDO\_SEL pin to connect the SPKVSS pin.

##### 3.8.1.2.1 Standby Mode

To put the device in standby mode, the SPKVDD supply and both 1.8V voltages (AVDD and DVDD) must stay on, all other blocks should be powered down. This state results in standby current of approximately 1.5uA from the AVDD supply. In standby mode the device responds very quickly to playback requests.

##### 3.8.1.2.2 Shutdown Mode

To shut down the device, the external supplies can be turned off completely. If the 1.8V rail cannot be turned off, the PLL and HP Level Shifters must be powered down (Page 1, Register 2, D3 = 1), the LDO bandgap must be powered down (Page 1, Register 1, D1 = 1), power down the POR circuit (Page 1, Register 1, D3 = 1) and the

Master Reference must be powered down (Page 1, Register 1, D4 = 0). This state results in a device shutdown current < 1.5 $\mu$ A.

### 3.8.1.3 Other Supply Options

There are other options to power the device. Apply the following rules:

- During normal operation all supply pins must be connected to a supply (via internal LDO or external).
- Whenever the LDO supply is present,
- Power Supplies:
  - The SPKVDD supply must be present as well
  - The DVDD supply must be present as well
  - If the AVDD supply is not present, then the PLL and HP Level Shifters must be powered down (Page 1, Register 2, D3 = 1) and the Master Reference must be powered down (Page 1, Register 1, D4 = 0). Also all other blocks should be powered down.

## 3.9 Device Special Functions

### 3.9.1 Interrupts

Some specific events in the TAS2505 which may require host processor intervention, can be used to trigger interrupts to the host processor. This avoids polling the status-flag registers continuously. The TAS2505 has two defined interrupts; INT1 and INT2 that can be configured by programming Page 0, Register 48 and 49. A user can configure the interrupts INT1 and INT2 to be triggered by one or many events such as

- Over-current condition in headphone driver
- Data Overflow in AC Processing Blocks and Filters

Each of these INT1 and INT2 interrupts can be routed to output pins like GPIO/DOUT and MISO by configuring the respective output control registers in Page 0, Register 52, 53 and 55. These interrupt signals can either be configured as a single pulse or a series of pulses by programming Page 0, Register 48, D(0) and Page 0, Register 49, D(0). If the user configures the interrupts as a series of pulses, the events will trigger the start of pulses that will stop when the flag registers in Page 0, Register 42 and 44 are read by the user to determine the cause of the interrupt.

This page intentionally left blank.



The requirements of the application circuit determine device setup details such as clock generation, power sources, reference voltage, and special functions that may add value to the end application. Example device setups are described in the next chapter.

### 4.1 Power On Sequence

There are two recommended power sequences possible for TAS2505:

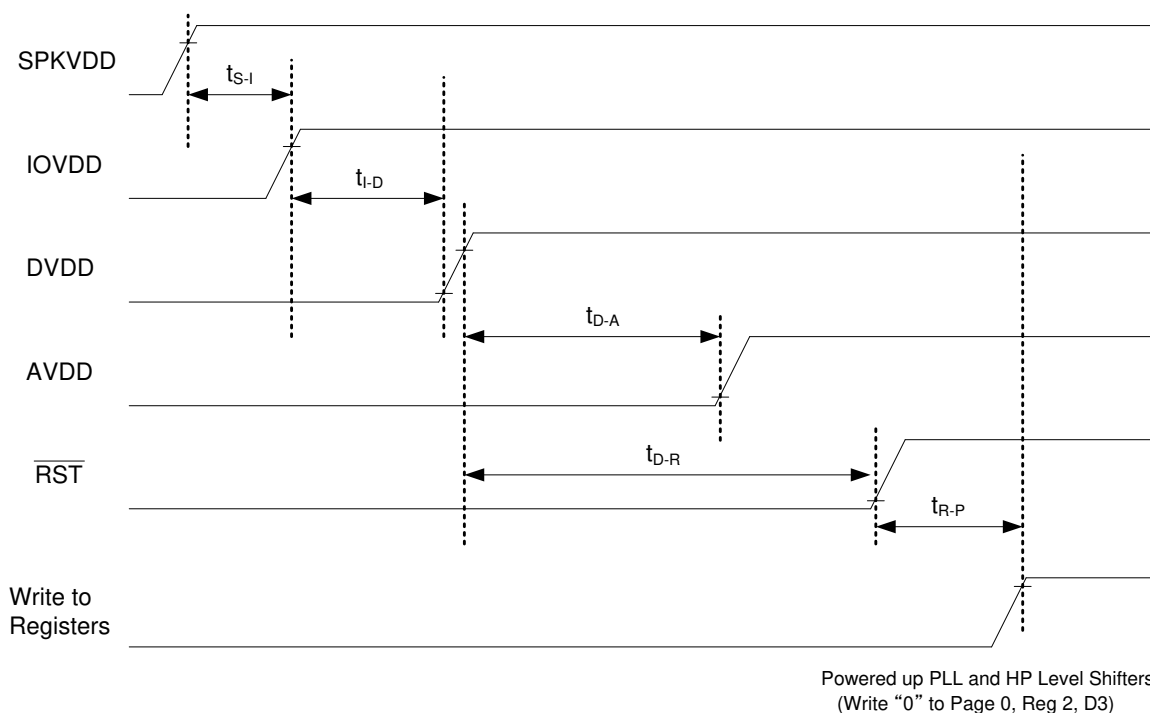
1. Speaker Supplies, then Digital Supplies, then Analog Supplies
2. Speaker Supplies, then Digital and Analog Supplies

The first power on sequence is useful if the end system uses separate analog and digital supplies. This is useful to improve the efficiency of the digital rails by using a DC/DC converter, while keeping the analog supplies clean by using a low-dropout regulator(s) (LDO). While it is recommended to separate analog and digital supplies, if all the 1.8 V supplies (analog and digital) must be tied together, the second power sequence can be utilized and this sequence can adopt in case of using the internal LDO.

***In any of the power sequence cases, the input clocks BCLK, WCLK, and MCLK (if used) must be enabled before writing into the device registers for initialization. If these clocks are stopped at any time, at least the Class-D speaker output must be disabled (Page 1 Register 45 Bit D1) or muted (Page 1 Register 48 bits D6-D4) to prevent audio artifacts at the speaker.***

#### 4.1.1 Power On Sequence 1 – Separate Digital and Analog Supplies

Figure 4-1 shows a timing diagram for the case where all supplies are provided separately. If the depicted sequence should be used.


**Figure 4-1. Analog Supply provided after Digital Supply**

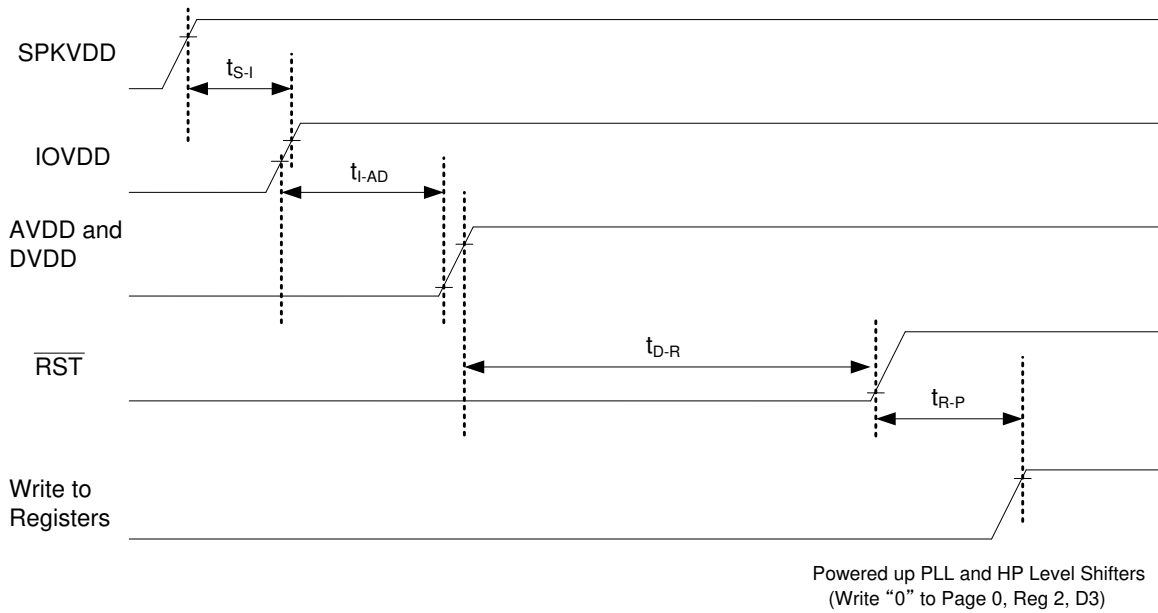
SPKVDD should be provided first. Next, IOVDD should be provided, and DVDD can be provided at the same time as IOVDD. Since, by default, the PLL and HP Level Shifters which work from the DVDD rail to the AVDD rail is powered down so that even if rising up AVDD is delayed from rising up DVDD, the shifters can help the leakage currents from DVDD to AVDD. After  $\overline{RST}$  is released (or a software reset is performed), no register writes should be performed within 1 ms.

**Table 4-1. Power Supply Timing Parameters**

Parameter	Minimum	Typical	Maximum	Comments
$t_{S-I}$	0			Time between SPKVDD is provided and IOVDD is provided.
$t_{I-D}$	0			Time between IOVDD is provided and DVDD is provided.
$t_{D-A}$	0			Time between DVDD is provided and AVDD is provided.
$t_{D-R}$	10 ns			Time between DVDD (and IOVDD) is provided and reset can be released.
$t_{R-P}$	1 ms			Time between release of the reset and when registers can be written (that is, Powered up PLL and HP Level Shifters).

#### 4.1.2 Power On Sequence 2 – Shared 1.8 V Analog Supply to DVDD

If desired, the analog supply of AVDD could also be supplied at the same time as DVDD if the one supply is from the internal LDO or is external. This is shown in the [Figure 4-2](#).



**Figure 4-2. Digital and Analog 1.8 V Supplies provided Together**

After  $\overline{RST}$  is released (or a software reset is performed), no register writes should be performed within 1 ms.

**Table 4-2. Power Supply Timing Parameters**

Parameter	Minimum	Typical	Maximum	Comments
$t_{I-S}$	0			Time between SPKVDD is provided and IOVDD is provided.
$t_{I-AD}$	0			Time between IOVDD is provided and, AVDD and DVDD are provided.
$t_{D-R}$	10 ns			Time between DVDD (and IOVDD) is provided and reset can be released.
$t_{R-P}$	1 ms			Time between release of the reset and when registers can be written (that is Powered up PLL and HP Level Shifters).

## 4.2 Device Initialization

### 4.2.1 Reset by $\overline{RST}$ pin and POR

The TAS2505 internal logic must be initialized to a known condition for proper device function. This can be accomplished in two ways:

1. The first way is to take no action and let the internal POR circuit that detects the minimum DVDD and IOVDD levels automatically reset the device into its default condition.
2. If required, the  $\overline{RST}$  pin can be used. To initialize the device to its default operating condition, the hardware reset pin ( $\overline{RST}$ ) can be pulled low for at least 10 ns. For this initialization to work, both the IOVDD and DVDD supplies must be powered up. It is recommended that while the DVDD supply is being powered up, the  $\overline{RST}$  pin be pulled low.

The device can also be reset via software reset. Writing a 1 into page 0, register 1, bit D0 resets the internal registers, but not the digital interface.

### 4.2.2 Device Start-Up Lockout Times

After the TAS2505 is initialized through the power up process, the internal memories are initialized to default values. This initialization takes place within 1 ms after the power up process. During this initialization phase, no register-read or register-write operation should be performed on the DAC coefficient buffers. Also, no block within the codec should be powered up during the initialization phase.

### 4.2.3 PLL Start-Up

Whenever the PLL is powered up, a start-up delay of approximately of 10 ms occurs after the power-up command of the PLL and before the clocks are available to the codec. This delay is to ensure stable operation of the PLL and clock-divider logic.

### 4.2.4 Power-Stage Reset

The power-stage-only reset is used to reset the device after an overcurrent latching shutdown has occurred. Using this reset re-enables the output stage without resetting all of the registers in the device. Each of the two power stages has its own dedicated reset bit. The headphone power-stage reset is performed by setting page 1, register 9, bit D5 for HPOUT. If a short circuit is detected at Headphone output, page 1, register 11, bit D0 will power down the driver. The speaker power-stage reset is performed by setting page 1 / register 45, bit D1 for SPKP and SPKM.

### 4.2.5 Software Power Down

By default, all circuit blocks are powered down following a reset condition. Hardware power up of each circuit block can be controlled by writing to the appropriate control register. This approach allows the lowest power-supply current for the functionality required. However, when a block is powered down, all of the register settings are maintained as long as power is still being applied to the device.

#### 4.2.6 Device Common Mode Voltage

The TAS2505 allows the user to set the common mode voltage for analog inputs to 0.75V or 0.9V by programming Page 1, Register 10, D(6). The input common-mode voltage of 0.9V works best when the analog supply voltage is centered around 1.8V or above, and offers the highest possible performance. For analog supply voltages below 1.8V, a common mode voltage of 0.75V must be used.

**Table 4-3. Input Common Mode voltage and Input Signal Swing**

Input Common Mode Voltage (V)	AVdd (V)	Channel Gain (dB)	Single-Ended Input Swing for 0dBFS output signal ( $V_{RMS}$ )	Differential Input Swing for 0dBFS output signal ( $V_{RMS}$ )
0.75	>1.5	-2	0.375	0.75
0.90	1.8 ... 1.95	0	0.5	1.0

---

**Note**

The input common mode setting is common for DAC playback and Analog Bypass path.

---

This page intentionally left blank.



The following example EVM I<sup>2</sup>C register control scripts can be taken directly for the TAS2505 EVM setup. The # marks a comment line, w marks an I<sup>2</sup>C write command followed by the device address, the I<sup>2</sup>C register address and the value. The EVM I<sup>2</sup>C register control scripts follows to show how to set up the TAS2505 in playback mode with  $f_s = 44.1$  kHz and MCLK = 11.2896 MHz.

### 5.1 Example Register Setup to Play Digital Data Through DAC and Headphone/Speaker Outputs

```
# I2C Script to Setup the device in Playback Mode
# Key: w 30 XX YY ==> write to I2C address 0x30, to register 0xxx, data 0xyy
# This script set DAC output routed to HP Driver and Class-D driver via Mixer
# # ==> comment delimiter
# Page switch to Page 0
w 30 00 00
# Assert Software reset (P0, R1, D0=1)
w 30 01 01
# Page Switch to Page 1
w 30 00 01
# LDO output programmed as 1.8V and Level shifters powered up. (P1, R2, D5-D4=00, D3=0)
w 30 02 00
# Page switch to Page 0
w 30 00 00
# PLL_clkln = MCLK, codec_clkln = PLL_CLK, MCLK should be 11.2896MHz (P0, R4, D1-D0=03)
w 30 04 03
# Power up PLL, set P=1, R=1, (Page-0, Reg-5)
w 30 05 91
# Set J=4, (Page-0, Reg-6)
w 30 06 04
# D = 0000, D(13:8) = 0, (Page-0, Reg-7)
w 30 07 00
# D(7:0) = 0, (Page-0, Reg-8)
w 30 08 00
# add delay of 15 ms for PLL to lock
d 15
# DAC NDAC Powered up, NDAC=4 (P0, R11, D7=1, D6-D0=0000100)
w 30 0B 84
# DAC MDAC Powered up, MDAC=2 (P0, R12, D7=1, D6-D0=0000010)
w 30 0C 82
# DAC OSR(9:0)-> DOSR=128 (P0, R12, D1-D0=00)
w 30 0D 00
# DAC OSR(9:0)-> DOSR=128 (P0, R13, D7-D0=10000000)
w 30 0E 80
# Codec Interface control word length = 16bits, BCLK&WCLK inputs, I2S mode. (P0, R27, D7-D6=00, D5-D4=00, D3-D2=00)
w 30 1B 00
# Data slot offset 00 (P0, R28, D7-D0=0000)
w 30 1C 00
# Dac Instruction programming PRB #2 for Mono routing. Type interpolation (x8) and 3 programmable Biquads. (P0, R60, D4-D0=0010)
w 30 3C 02
# Page switch to Page 0
w 30 00 00
# DAC powered up, Soft step 1 per Fs. (P0, R63, D7=1, D5-D4=01, D3-D2=00, D1-D0=00)
w 30 3F 90
# DAC digital gain 0dB (P0, R65, D7-D0=00000000)
w 30 41 00
# DAC volume not muted. (P0, R64, D3=0, D2=1)
w 30 40 04
# Page Switch to Page 1
w 30 00 01
```

```
# Master Reference Powered on (P1, R1, D4=1)
w 30 01 10
# Output common mode for DAC set to 0.9V (default) (P1, R10)
w 30 0A 00
# Mixer P output is connected to HP Out Mixer (P1, R12, D2=1)
w 30 0C 04
# HP Volume, 0dB Gain (P1, R22, D6-D0=0000000)
w 30 16 00
# No need to enable Mixer M and Mixer P, AINL Volume, 0dB Gain (P1, R24, D7=1, D6-D0=0000000)
w 30 18 00
# Power up HP (P1, R9, D5=1)
w 30 09 20
# Unmute HP with 0dB gain (P1, R16, D4=1)
w 30 10 00
# SPK attn. Gain =0dB (P1, R46, D6-D0=000000)
w 30 2E 00
# SPK driver Gain=6.0dB (P1, R48, D6-D4=001)
w 30 30 10
# SPK powered up (P1, R45, D1=1)
w 30 2D 02
#
```

## 5.2 Example Register Setup to Play Digital Data Through DAC and Headphone Output

```
# I2C Script to Setup the device in Playback Mode
# Key: w 30 XX YY ==> write to I2C address 0x30, to register 0xxx, data 0xyy
# This script set DAC output routed to only HP Driver
# # ==> comment delimiter
#
# Page switch to Page 0
w 30 00 00
# Assert Software reset (P0, R1, D0=1)
w 30 01 01
# Page Switch to Page 1
w 30 00 01
# LDO output programmed as 1.8V and Level shifters powered up. (P1, R2, D5-D4=00, D3=0)
w 30 02 00
Page switch to Page 0
w 30 00 00
# CODEC_CLKIN=MCLK, MCLK should be 11.2896MHz (P0, R4, D1-D0=00)
w 30 04 00
# DAC NDAC Powered up, NDAC=1 (P0, R11, D7=1, D6-D0=0000001)
w 30 0B 81
# DAC MDAC Powered up, MDAC=2 (P0, R12, D7=1, D6-D0=0000010)
w 30 0C 82
# DAC OSR(9:0)-> DOSR=128 (P0, R12, D1-D0=00)
w 30 0D 00
# DAC OSR(9:0)-> DOSR=128 (P0, R13, D7-D0=10000000)
w 30 0E 80
# Codec Interface control word length = 16bits, BCLK&WCLK inputs, I2S mode. (P0, R27, D7-D6=00, D5-D4=00, D3-D2=00)
w 30 1B 00
# Data slot offset 00 (P0, R28, D7-D0=0000)
w 30 1C 00
# Dac Instruction programming PRB #2 for Mono routing. Type interpolation (x8) and 3 programmable Biquads. (P0, R60, D4-D0=0010)
w 30 3C 02
# Page Switch to Page 1
w 30 00 01
# Master Reference Powered on (P1, R1, D4=1)
w 30 01 10
# Output common mode for DAC set to 0.9V (default) (P1, R10)
w 30 0A 00
# DAC output is routed directly to HP driver (P1, R12, D3=1)
w 30 0C 08
# HP Volume, 0dB Gain (P1, R22, D6-D0=0000000)
w 30 16 00
# Power up HP (P1, R9, D5=1)
w 30 09 20
# Unmute HP with 0dB gain (P1, R16, D4=1)
w 30 10 00
# Page switch to Page 0
w 30 00 00
# DAC powered up, Soft step 1 per Fs. (P0, R63, D7=1, D5-D4=01, D3-D2=00, D1-D0=00)
```

```

w 30 3F 90
# DAC digital gain 0dB (P0, R65, D7-D0=00000000)
w 30 41 00
# DAC volume not muted. (P0, R64, D3=0, D2=1)
w 30 40 04
#

```

### 5.3 Example Register Setup to Play AINL and AINR Through Headphone/Speaker Outputs

```

# I2C Script to Setup the device in Playback Mode
# This script set AINL and AINR inputs routed to HP Driver and Class-D driver via Mixer
# Key: w 30 XX YY ==> write to I2C address 0x30, to register 0xxx, data 0xyy
# # ==> comment delimiter
#
# Page switch to Page 0
w 30 00 00
# Assert Software reset (P0, R1, D0=1)
w 30 01 01
# Page Switch to Page 1
w 30 00 01
# LDO output programmed as 1.8V and Level shifters powered up. (P1, R2, D5-D4=00, D3=0)
w 30 02 00
# Master Reference Powered on (P1, R1, D4=1)
w 30 01 10
# Enable AINL and AINR (P1, R9, D1-D0=11)
w 30 09 03
# AINL/R to HP driver via Mixer P (P1, R12, D7-D6=11, D2=1)
w 30 0C C4
# HP Volume, 0dB Gain (P1, R22, D6-D0=00000000)
w 30 16 00
# Enable Mixer P and Mixer M, AINL Volume, 0dB Gain (P1, R24, D7=1, D6-D0=00000000)
w 30 18 80
# Enable AINL and AINR and Power up HP (P1, R9, D5=1, D1-D0=11)
w 30 09 23
# Unmute HP with 0dB gain (P1, R16, D4=1)
w 30 10 00
# SPK attn. Gain =0dB (P1, R46, D6-D0=00000000)
w 30 2E 00
# SPK driver Gain=6.0dB (P1, R48, D6-D4=001)
w 30 30 10
# SPK powered up (P1, R45, D1=1)
w 30 2D 02
#

```

### 5.4 Example Register Setup to Play AINL and AINR Through Headphone Output

```

# I2C Script to Setup the device in Playback Mode
# This script set AINL and AINR inputs routed to only HP Driver
# Key: w 30 XX YY ==> write to I2C address 0x30, to register 0xxx, data 0xyy
# # ==> comment delimiter
#
# Page switch to Page 0
w 30 00 00
# Assert Software reset (P0, R1, D0=1)
w 30 01 01
# Page Switch to Page 1
w 30 00 01
# LDO output programmed as 1.8V and Level shifters powered up. (P1, R2, D5-D4=00, D3=0)
w 30 02 00
# Master Reference Powered on (P1, R1, D4=1)
w 30 01 10
# Enable AINL and AINR (P1, R9, D1-D0=11)
w 30 09 03
# AINL/R to HP driver not via Mixer P (P1, R12, D1-D0=11)
w 30 0C 03
# HP Volume, 0dB Gain (P1, R22, D6-D0=00000000)
w 30 16 00
# Not enable HP Out Mixer, AINL Volume, 0dB Gain (P1, R24, D7=0, D6-D0=00000000)
w 30 18 00
# Enable AINL and AINR and Power up HP (P1, R9, D5=1, D1-D0=11)
w 30 09 23
# Unmute HP with 0dB gain (P1, R16, D4=1)

```

```
w 30 10 00
#
```

## 5.5 Example Register Setup to Play Digital Data Through DAC and Headphone/Speaker Outputs With 3 Programmable Biquads

```
# I2C Script to Setup the device in Playback Mode #2
# Key: w 30 XX YY ==> write to I2C address 0x30, to register 0xxx, data 0xyy
# This script set DAC output routed to HP Driver and Class-D driver via Mixer with 3 programmable
Biquads.
# # ==> comment delimiter
#
# Page switch to Page 0
w 30 00 00
# Assert Software reset (P0, R1, D0=1)
w 30 01 01
# Page Switch to Page 1
w 30 00 01
# LDO output programmed as 1.8V and Level shifters powered up. (P1, R2, D5-D4=00, D3=0)
w 30 02 00
# Page switch to Page 0
w 30 00 00
# CODEC_CLKIN=MCLK, MCLK should be 11.2896MHZ (P0, R4, D1-D0=00)
w 30 04 00
# DAC NDAC Powered up, NDAC=1 (P0, R11, D7=1, D6-D0=0000001)
w 30 0B 81
# DAC MDAC Powered up, MDAC=2 (P0, R12, D7=1, D6-D0=0000010)
w 30 0C 82
# DAC OSR(9:0)-> DOSR=128 (P0, R12, D1-D0=00)
w 30 0D 00
# DAC OSR(9:0)-> DOSR=128 (P0, R13, D7-D0=10000000)
w 30 0E 80
# Codec Interface control word length = 16bits, BCLK&WCLK inputs, I2S mode. (P0, R27, D7-D6=00,
D5-D4=00, D3-D2=00)
w 30 1B 00
# Data slot offset 00 (P0, R28, D7-D0=0000)
w 30 1C 00
# Dac Instruction programming PRB #2 for Mono routing. Type interpolation (x8) and 3 programmable
Biquads. (P0, R60, D4-D0=0010)
w 30 3C 02
#####----- BEGIN COEFFICIENTS -----
# reg 00 - Page Select Register = 44
# sets active page to page 44 for 3-BQs (BQ-A, BQ-B, BQ-C)
w 30 00 2C
#
#-----
# BQ-A = 100Hz HP
#-----
# reg 12/13/14 - N0 Coefficient
w 30 0C 7E B7 7B
# reg 16/17/18 - N1 Coefficient
w 30 10 81 48 85
# reg 20/21/22 - N2 Coefficient
w 30 14 7E B7 7B
# reg 24/25/26 - D1 Coefficient
w 30 18 7E B5 D5
# reg 28/29/30 - D2 Coefficient
w 30 1C 82 8D BE
#
#-----
# BQ-B = 1 KHZ Notch BW = 25
#-----
# reg 32/33/34 - N0 Coefficient
w 30 20 7F C5 BD
# reg 36/37/38 - N1 Coefficient
w 30 24 81 85 B1
# reg 40/41/42 - N2 Coefficient
w 30 28 7F C5 BD
# reg 44/45/46 - D1 Coefficient
w 30 2C 7E 7A 4F
# reg 48/49/50 - D2 Coefficient
w 30 30 80 74 84
#
#-----
# BQ-C = 5 KHZ Notch BW = 125
#-----
```

```

# reg 52/53/54 - N0 Coefficient
w 30 34 7E DE C5
# reg 56/57/58 - N1 Coefficient
w 30 38 9F FB C8
# reg 60/61/62 - N2 Coefficient
w 30 3C 7E DE C5
# reg 64/65/66 - D1 Coefficient
w 30 40 60 04 38
# reg 68/69/70 - D2 Coefficient
w 30 44 82 42 74
#####----- END COEFFICIENTS OF Notch Filters -----
#####
# Page switch to Page 0
w 30 00 00
# DAC powered up, Soft step 1 per Fs. (P0, R63, D7=1, D5-D4=01, D3-D2=00, D1-D0=00)
w 30 3F 90
# DAC digital gain 0dB (P0, R65, D7-D0=00000000)
w 30 41 00
# DAC volume not muted. (P0, R64, D3=0, D2=1)
w 30 40 04
#
# Page Switch to Page 1
w 30 00 01
# Master Reference Powered on (P1, R1, D4=1)
w 30 01 10
# Output common mode for DAC set to 0.9V (default) (P1, R10)
w 30 0A 00
# Mixer P output is connected to HP Out Mixer (P1, R12, D2=1)
w 30 0C 04
# HP Volume, 0dB Gain (P1, R22, D6-D0=00000000)
w 30 16 00
# Power up HP (P1, R9, D5=1)
w 30 09 20
# Unmute HP with 0dB gain (P1, R16, D4=1)
w 30 10 00
#
# SPK attn. Gain =0dB (P1, R46, D6-D0=000000)
w 30 2E 00
#
# SPK driver Gain=6.0dB (P1, R48, D6-D4=001)
w 30 30 10
#
# SPK powered up (P1, R45, D1=1)
w 30 2D 02
#

```

## 5.6 Example Register Setup to Play Digital Data Through DAC and Headphone/Speaker Outputs With 6 Programmable Biquads

```

# I2C Script to Setup the device in Playback Mode #3
# Key: w 30 XX YY ==> write to I2C address 0x30, to register 0xxx, data 0yyy
# This script set DAC output routed to HP Driver and Class-D driver via Mixer with 6 programmable Biquads.
# # ==> comment delimiter
#
# Page switch to Page 0
w 30 00 00
# Assert Software reset (P0, R1, D0=1)
w 30 01 01
# Page Switch to Page 1
w 30 00 01
# LDO output programmed as 1.8V and Level shifters powered up. (P1, R2, D5-D4=00, D3=0)
w 30 02 00
# Page switch to Page 0
w 30 00 00
#
# CODEC_CLKIN=MCLK, MCLK should be 11.2896MHZ (P0, R4, D1-D0=00)
w 30 04 00
#
# DAC NDAC Powered up, NDAC=1 (P0, R11, D7=1, D6-D0=0000001)
w 30 0B 81
#
# DAC MDAC Powered up, MDAC=2 (P0, R12, D7=1, D6-D0=0000010)
w 30 0C 82
#
# DAC OSR(9:0)-> DOSR=128 (P0, R12, D1-D0=00)
w 30 0D 00
#
# DAC OSR(9:0)-> DOSR=128 (P0, R13, D7-D0=10000000)
w 30 0E 80
# Codec Interface control word length = 16bits, BCLK&WCLK inputs, I2S mode. (P0, R27, D7-D6=00, D5-D4=00, D3-D2=00)

```

**Example Setups**

```

w 30 1B 00
# Data slot offset 00 (P0, R28, D7-D0=0000)
w 30 1C 00
# Dac Instruction programming PRB #3 for Mono routing. Type B nterpolation (x4) and 6 programmable
Biquads. (P0, R60, D4-D0=0011)
w 30 3C 03
#####----- BEGIN COEFFICIENTS -----
# reg 00 - Page Select Register = 46
# sets active page to page 46 for First-Order IIR
w 30 00 2E
#-----
# First-Order IIR = 100Hz HP
#-----
# reg 28/29/30 - N0 Coefficient
w 30 1C 7F 18 36
# reg 32/33/34 - N1 Coefficient
w 30 20 80 E7 CA
# reg 36/37/38 - N2 Coefficient
w 30 24 7E 30 6D
# reg 00 - Page Select Register = 44
# sets active page to page 44 for 6-BQs (BQ-A, BQ-B, BQ-C, BQ-D, BQ-E, BQ-F)
w 30 00 2C
#
#-----
# BQ-A = 500Hz Notch BW = 25
#-----
# reg 12/13/14 - N0 Coefficient
w 30 0C 7F C5 BD
# reg 16/17/18 - N1 Coefficient
w 30 10 80 8D 39
# reg 20/21/22 - N2 Coefficient
w 30 14 7F C5 BD
# reg 24/25/26 - D1 Coefficient
w 30 18 7F 72 C7
# reg 28/29/30 - D2 Coefficient
w 30 1C 80 74 84
#-----
# BQ-B = 1 KHz Notch BW = 25
#-----
# reg 32/33/34 - N0 Coefficient
w 30 20 7F C5 BD
# reg 36/37/38 - N1 Coefficient
w 30 24 81 85 B1
# reg 40/41/42 - N2 Coefficient
w 30 28 7F C5 BD
# reg 44/45/46 - D1 Coefficient
w 30 2C 7E 7A 4F
# reg 48/49/50 - D2 Coefficient
w 30 30 80 74 84
#-----
# BQ-C = 2 KHz Notch BW = 25
#-----
# reg 52/53/54 - N0 Coefficient
w 30 34 7F C5 BD
# reg 56/57/58 - N1 Coefficient
w 30 38 85 61 46
# reg 60/61/62 - N2 Coefficient
w 30 3C 7F C5 BD
# reg 64/65/66 - D1 Coefficient
w 30 40 7A 9E BA
# reg 68/69/70 - D2 Coefficient
w 30 44 80 74 84
#-----
# BQ-D = 3 KHz Notch BW = 25
#-----
# reg 72/73/74 - N0 Coefficient
w 30 48 7F C5 BD
# reg 76/77/78 - N1 Coefficient
w 30 4C 8B B8 FD
# reg 80/81/82 - N2 Coefficient
w 30 50 7F C5 BD
# reg 84/85/86 - D1 Coefficient
w 30 54 74 47 03
# reg 88/89/90 - D2 Coefficient
w 30 58 80 74 84
#-----

```

```

# BQ-E = 4 KHz Notch BW = 25
#-----
# reg 92/93/94 - N0 Coefficient
w 30 5C 7F C5 BD
# reg 96/97/98 - N1 Coefficient
w 30 60 94 6B EF
# reg 100/101/102 - N2 Coefficient
w 30 64 7F C5 BD
# reg 104/105/106 - D1 Coefficient
w 30 68 6B 94 11
# reg 108/109/110 - D2 Coefficient
w 30 6C 80 74 84
#-----
# BQ-F = 5 KHz Notch BW = 25
#-----
# reg 112/113/114 - N0 Coefficient
w 30 70 7F C5 BD
# reg 116/117/118 - N1 Coefficient
w 30 74 9F 4C FB
# reg 120/121/122 - N2 Coefficient
w 30 78 7F C5 BD
# reg 124/125/126 - D1 Coefficient
w 30 7C 60 B3 05
# sets active page to page 45 for BQ-F D2
w 30 00 2D
# reg 8/9/10 - D2 Coefficient
w 30 08 80 74 84
#####----- END COEFFICIENTS OF Notch Filters -----
#####
# Page switch to Page 0
w 30 00 00
# DAC powered up, Soft step 1 per Fs. (P0, R63, D7=1, D5-D4=01, D3-D2=00, D1-D0=00)
w 30 3F 90
# DAC digital gain 0dB (P0, R65, D7-D0=00000000)
w 30 41 00
# DAC volume not muted. (P0, R64, D3=0, D2=1)
w 30 40 04
#
# Page Switch to Page 1
w 30 00 01
# Master Reference Powered on (P1, R1, D4=1)
w 30 01 10
# Output common mode for DAC set to 0.9V (default) (P1, R10)
w 30 0A 00
# Mixer P output is connected to HP Out Mixer (P1, R12, D2=1)
w 30 0C 04
# HP Volume, 0dB Gain (P1, R22, D6-D0=00000000)
w 30 16 00
# Power up HP (P1, R9, D5=1)
w 30 09 20
# Unmute HP with 0dB gain (P1, R16, D4=1)
w 30 10 00
#
# SPK attn. Gain =0dB (P1, R46, D6-D0=000000)
w 30 2E 00
#
# SPK driver Gain=6.0dB (P1, R48, D6-D4=001)
w 30 30 10
#
# SPK powered up (P1, R45, D1=1)
w 30 2D 02
#

```

This page intentionally left blank.



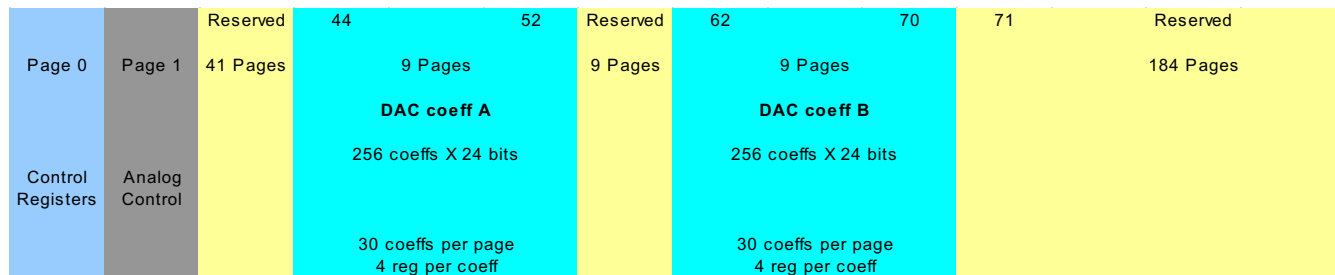
## 6.1 TAS2505 Register Map

All features on this device are addressed using the I<sup>2</sup>C bus or SPI. All of the writable registers can be read back. However, some registers contain status information or data, and are available for reading only.

The TAS2505 contains several pages of 8-bit registers, and each page can contain up to 128 registers. The register pages are divided up based on functional blocks for this device. Page 0 is the default home page after RST. Page control is done by writing a new page value into register 0 of the current page.

The control registers for the TAS2505 are described in detail as follows. All registers are 8 bits in width, with D7 referring to the most-significant bit of each register, and D0 referring to the least-significant bit.

Pages 0, 1, 44-52 and 62-70 are available for use; however, all other pages and registers are reserved. Do not read from or write to reserved pages and registers. Also, do not write other than the Reset Values for the reserved bits and read-only bits of non-reserved registers; otherwise, device functionality failure can occur.



**Table 6-1. Summary of Register Map**

Page Number	Description
0	Control Registers, Page 0 (Default Page): Clock Multipliers, Dividers, Serial Interfaces, Flags, Interrupts, and GPIOs. See <a href="#">Section 6.1.1</a> .
1	Control Registers, Page 1: DAC Routing, Power-Controls and MISC Logic Related Programmabilities. See <a href="#">Section 6.1.2</a> .
8 - 43	Page 8 - 43: Reserved Registers
44	Page 44: DAC Programmable Coefficients RAM. See <a href="#">Section 6.1.4</a> and <a href="#">Section 6.1.9</a> .
45 - 52	Page 45 - 52: DAC Programmable Coefficients RAM. See <a href="#">Section 6.1.5</a> and <a href="#">Section 6.1.9</a> .
53 - 61	Page 53 - 61: Reserved Registers
62 - 70	Page 62 - 70: DAC Programmable Coefficients RAM. See <a href="#">Section 6.1.7</a> and <a href="#">Section 6.1.9</a> .
71 - 255	Page 71 -255: Reserved Registers

### 6.1.1 Control Registers, Page 0 (Default Page): Clock Multipliers, Dividers, Serial Interfaces, Flags, Interrupts, and GPIOs

#### Page 0 / Register 0: Page Select Register - 0x00 / 0x00

BIT	Read/Write	Reset Value	DESCRIPTION
D7–D0	R/W	0000 0000	0-255: Selects the Register Page for next read or write command. See the Table "Summary of Memory Map" for details.

#### Page 0 / Register 1: Software Reset Register - 0x00 / 0x01

BIT	Read/Write	Reset Value	DESCRIPTION
D7–D1	R	0000 000	Reserved. Write only zeros to these bits.
D0	W	0	Self clearing software reset bit 0: Don't care 1: Self-clearing software reset

#### Page 0 / Register 2: Reserved Register - 0x00 / 0x02

BIT	Read/Write	Reset Value	DESCRIPTION
D7-D0	R	0XXX 0XXX	Reserved. Do not write to this register. (Read Only)

#### Page 0 / Register 3: Reserved Register - 0x00 / 0x03

BIT	Read/Write	Reset Value	DESCRIPTION
D7–D0	R/W	0000 0000	Reserved. Write only zeros to these bits.

#### Page 0 / Register 4: Clock Setting Register 1, Multiplexers - 0x00 / 0x04

BIT	Read/Write	Reset Value	DESCRIPTION
D7	R	0	Reserved. Write only the default value.
D6	R/W	0	Select PLL Range 0: Low PLL Clock Range 1: High PLL Clock Range
D5-D4	R	00	Reserved. Write only the default values.
D3-D2	R/W	00	Select PLL Input Clock 00: MCLK pin is input to PLL 01: BCLK pin is input to PLL 10: GPIO pin is input to PLL 11: DIN pin is input to PLL
D1-D0	R/W	00	Select CODEC_CLKIN 00: MCLK pin is CODEC_CLKIN 01: BCLK pin is CODEC_CLKIN 10: GPIO pin is CODEC_CLKIN 11: PLL Clock is CODEC_CLKIN

#### Page 0 / Register 5: Clock Setting Register 2, PLL P and R Values - 0x00 / 0x05

BIT	Read/Write	Reset Value	DESCRIPTION
D7	R/W	0	0: PLL is powered down. 1: PLL is powered up.
D6–D4	R/W	001	000: PLL divider P = 8 001: PLL divider P = 1 010: PLL divider P = 2 ... 110: PLL divider P = 6 111: PLL divider P = 7

**Page 0 / Register 5: Clock Setting Register 2, PLL P and R Values - 0x00 / 0x05 (continued)**

D3–D0	R/W	0001	0000: Reserved. Do not use 0001: PLL multiplier R = 1 0010: PLL multiplier R = 2 0011: PLL multiplier R = 3 0100: PLL multiplier R = 4 ... 0101...0111: Reserved. Do not use
-------	-----	------	--

**Page 0 / Register 6: Clock Setting Register 3, PLL J Values - 0x00 / 0x06**

BIT	Read/Write	Reset Value	DESCRIPTION
D7–D6	R	00	Reserved. Write only the default values.
D5–D0	R/W	00 0100	PLL divider J value 00 0000...00 0011: Do not use 00 0100: J = 4 00 0101: J = 5 ... 11 1110: J = 62 11 1111: J = 63

**Page 0 / Register 7: Clock Setting Register 4, PLL D Values (MSB) - 0x00 / 0x07**

BIT	Read/Write	Reset Value	DESCRIPTION
D7–D6	R	00	Reserved. Write only default values.
D5–D0	R/W	00 0000	PLL divider D value (MSB) PLL divider D value(MSB) and PLL divider D value(LSB) 00 0000 0000 0000: D=0000 00 0000 0000 0001: D=0001 ... 10 0111 0000 1110: D=9998 10 0111 0000 1111: D=9999 10 0111 0001 0000...11 1111 1111 1111: Do not use Note: This register will be updated only when the Page-0, Reg-8 is written immediately after Page-0, Reg-7.

**Page 0 / Register 8: Clock Setting Register 5, PLL D Values (LSB) - 0x00 / 0x08**

BIT	Read/Write	Reset Value	DESCRIPTION
D7–D0	R/W	0000 0000	PLL divider D value (LSB) PLL divider D value(MSB) and PLL divider D value(LSB) 00 0000 0000 0000: D=0000 00 0000 0000 0001: D=0001 ... 10 0111 0000 1110: D=9998 10 0111 0000 1111: D=9999 10 0111 0001 0000...11 1111 1111 1111: Do not use Note: Page-0, Reg-8 should be written immediately after Page-0, Reg-7.

**Page 0 / Registers 9–10: Reserved - 0x00 / 0x09-0x0A**

BIT	Read/Write	Reset Value	DESCRIPTION
D7–D0	R/W	0000 0000	Reserved. Write only the default values.

**Page 0 / Register 11: Clock Setting Register 6, NDAC Values - 0x00 / 0x0B**

BIT	Read/Write	Reset Value	DESCRIPTION
D7	R/W	0	NDAC Divider Power Control 0: NDAC divider powered down 1: NDAC divider powered up

**Page 0 / Register 11: Clock Setting Register 6, NDAC Values - 0x00 / 0x0B (continued)**

D6–D0	R/W	000 0001	NDAC Value 000 0000: NDAC=128 000 0001: NDAC=1 000 0010: NDAC=2 ... 111 1110: NDAC=126 111 1111: NDAC=127 Note: Please check the clock frequency requirements in the Overview section.
-------	-----	----------	---

**Page 0 / Register 12: Clock Setting Register 7, MDAC Values - 0x00 / 0x0C**

BIT	Read/Write	Reset Value	DESCRIPTION
D7	R/W	0	MDAC Divider Power Control 0: MDAC divider powered down 1: MDAC divider powered up
D6–D0	R/W	000 0001	MDAC Value 000 0000: MDAC=128 000 0001: MDAC=1 000 0010: MDAC=2 ... 111 1110: MDAC=126 111 1111: MDAC=127 Note: Please check the clock frequency requirements in the Overview section.

**Page 0 / Register 13: DAC OSR Setting Register 1, MSB Value - 0x00 / 0x0D**

BIT	Read/Write	Reset Value	DESCRIPTION
D7–D2	R	0000 00	Reserved. Write only the default values.
D1–D0	R/W	00	DAC OSR (DOSR) MSB Setting DAC OSR(MSB) and DAC OSR (LSB) 00 0000 0000: DOSR=1024 00 0000 0001: DOSR=1 00 0000 0010: DOSR=2 ... 11 1111 1110: DOSR=1022 11 1111 1111: DOSR=1023 Note: This register is updated when Page-0, Reg-14 is written to immediately after Page-0, Reg-13.

**Page 0 / Register 14: DAC OSR Setting Register 2, LSB Value - 0x00 / 0x0E**

BIT	Read/Write	Reset Value	DESCRIPTION
D7–D0	R/W	1000 0000	DAC OSR (DOSR) LSB Setting DAC OSR(MSB) and DAC OSR (LSB) 00 0000 0000: DOSR=1024 00 0000 0001: DOSR=1 00 0000 0010: DOSR=2 ... 11 1111 1110: DOSR=1022 11 1111 1111: DOSR=1023 Note: This register should be written immediately after Page-0, Reg-13.

**Page 0 / Register 15: Reserved Register - 0x00 / 0x0F**

BIT	Read/Write	Reset Value	DESCRIPTION
D7	R	0000 0010	Reserved. Write only the default values.

**Page 0 / Registers 16 - 24: Reserved Register - 0x00 / 0x10 - 0x12**

BIT	Read/Write	Reset Value	DESCRIPTION
D7–D0	R	0000 0000	Reserved. Write only the default value.

**Page 0 / Registers 25: Clock Setting Register 10, Multiplexers - 0x00 / 0x19**

BIT	Read/Write	Reset Value	DESCRIPTION
-----	------------	-------------	-------------

**Page 0 / Registers 25: Clock Setting Register 10, Multiplexers - 0x00 / 0x19 (continued)**

D7–D3	R	0000 0	Reserved. Write only the default values.
D2–D0	R/W	000	CDIV_CLKIN Clock Selection 000: CDIV_CLKIN = MCLK 001: CDIV_CLKIN = BCLK 010: CDIV_CLKIN = DIN 011: CDIV_CLKIN = PLL_CLK 100: CDIV_CLKIN = DAC_CLK 101: CDIV_CLKIN = DAC_MOD_CLK

**Page 0 / Registers 26: Clock Setting Register 11, CLKOUT M divider value - 0x00 / 0x1A**

BIT	Read/Write	Reset Value	DESCRIPTION
D7	R/W	0	CLKOUT M divider power control 0: CLKOUT M divider is powered down. 1: CLKOUT M divider is powered up.
D6–D0	R/W	000 0001	CLKOUT M divider value 000 0000: CLKOUT divider M = 128 000 0001: CLKOUT divider M = 1 000 0010: CLKOUT divider M = 2 ... 111 1110: CLKOUT divider M = 126 111 1111: CLKOUT divider M = 127 Note: Check the clock frequency requirements in the application overview section.

**Page 0 / Register 27: Audio Interface Setting Register 1 - 0x00 / 0x1B**

BIT	Read/Write	Reset Value	DESCRIPTION
D7–D6	R/W	00	Audio Interface Selection 00: Audio Interface = I <sup>2</sup> S 01: Audio Interface = DSP 10: Audio Interface = RJF 11: Audio Interface = LJF
D5–D4	R/W	00	Audio Data Word length 00: Data Word length = 16 bits 01: Data Word length = 20 bits 10: Data Word length = 24 bits 11: Data Word length = 32 bits
D3	R/W	0	BCLK Direction Control 0: BCLK is input to the device 1: BCLK is output from the device
D2	R/W	0	WCLK Direction Control 0: WCLK is input to the device 1: WCLK is output from the device
D1	R	0	Reserved. Write only default value.
D0	R	0	Reserved. Write only default value.

**Page 0 / Register 28: Audio Interface Setting Register 2, Data offset setting - 0x00 / 0x1C**

BIT	Read/Write	Reset Value	DESCRIPTION
D7–D0	R/W	0000 0000	Data Offset Value 0000 0000: Data Offset = 0 BCLK's 0000 0001: Data Offset = 1 BCLK's ... 1111 1110: Data Offset = 254 BCLK's 1111 1111: Data Offset = 255 BCLK's

**Page 0 / Register 29: Audio Interface Setting Register 3 - 0x00 / 0x1D**

BIT	Read/Write	Reset Value	DESCRIPTION
D7–D6	R/W	00	Reserved. Write only default values.
D5	R/W	0	Reserved. Write only default value.
D4	R/W	0	Reserved. Write only default values.

**Page 0 / Register 29: Audio Interface Setting Register 3 - 0x00 / 0x1D (continued)**

D3	R/W	0	Audio Bit Clock Polarity Control 0: Default Bit Clock polarity 1: Bit Clock is inverted w.r.t. default polarity
D2	R/W	0	Primary BCLK and Primary WCLK Power control 0: Primary BCLK and Primary WCLK buffers are powered up when they are used in clock generation even when the codec is powered down 1: Primary BCLK and Primary WCLK buffers are powered down when the codec is powered down
D1–D0	R/W	00	BDIV_CLKIN Multiplexer Control 00: BDIV_CLKIN = DAC_CLK 01: BDIV_CLKIN = DAC_MOD_CLK 10: Do not use 11: Do not use

**Page 0 / Register 30: Clock Setting Register 12, BCLK N Divider- 0x00 / 0x1E**

BIT	Read/Write	Reset Value	DESCRIPTION
D7	R/W	0	BCLK N Divider Power Control 0: BCLK N-divider is powered down. 1: BCLK N-divider is powered up.
D6–D0	R/W	000 0001	BCLK N Divider value 000 0000: BCLK divider N = 128 000 0001: BCLK divider N = 1 ... 111 1110: BCLK divider N = 126 111 1111: BCLK divider N = 127

**Page 0 / Register 31: Audio Interface Setting Register 4, Secondary Audio Interface - 0x00 / 0x1F**

BIT	Read/Write	Reset Value	DESCRIPTION
D7	R	0	Reserved. Write only default values.
D6–D5	R/W	00	Secondary Bit Clock Multiplexer 00: Secondary Bit Clock = GPIO 01: Secondary Bit Clock = SCLK 10: Secondary Bit Clock = MISO 11: Secondary Bit Clock = DOUT
D4–D3	R/W	00	Secondary Word Clock Multiplexer 00: Secondary Word Clock = GPIO 01: Secondary Word Clock = SCLK 10: Secondary Word Clock = MISO 11: Secondary Word Clock = DOUT
D2-D1	R	00	Reserved. Write only default values.
D0	R/W	0	Secondary Data Input Multiplexer 0: Secondary Data Input = GPIO 1: Secondary Data Input = SCLK

**Page 0 / Register 32: Audio Interface Setting Register 5 - 0x00 / 0x20**

BIT	Read/Write	Reset Value	DESCRIPTION
D7–D4	R	0000	Reserved. Write only default values.
D3	R/W	0	Primary / Secondary Bit Clock Control 0: Primary Bit Clock(BCLK) is used for Audio Interface and Clocking 1: Secondary Bit Clock is used for Audio Interface and Clocking
D2	R/W	0	Primary / Secondary Word Clock Control 0: Primary Word Clock(WCLK) is used for Audio Interface 1: Secondary Word Clock is used for Audio Interface
D1	R	0	Reserved. Write only default values.
D0	R/W	0	Audio Data In Control 0: DIN is used for Audio Data In 1: Secondary Data In is used for Audio Data In

**Page 0 / Register 33: Audio Interface Setting Register 6 - 0x00 / 0x21**

BIT	Read/Write	Reset Value	DESCRIPTION
D7	R/W	0	BCLK Output Control 0: BCLK Output = Generated Primary Bit Clock 1: BCLK Output = Secondary Bit Clock Input
D6	R/W	0	Secondary Bit Clock Output Control 0: Secondary Bit Clock = BCLK input 1: Secondary Bit Clock = Generated Primary Bit Clock
D5–D4	R/W	00	WCLK Output Control 00: WCLK Output = Generated DAC_FS 01: Reserved. Do not use. 10: WCLK Output = Secondary Word Clock Input 11: Reserved. Do not use
D3–D2	R/W	00	Secondary Word Clock Output Control 00: Secondary Word Clock output = WCLK input 01: Secondary Word Clock output = Generated DAC_FS 10: Reserved. Do not use. 11: Reserved. Do not use
D1	R/W	0	Primary Data Out output control 0: Reserved. Do not use. 1: DOUT output = Secondary Data Input (Loopback)
D0	R/W	0	Secondary Data Out output control 0: Secondary Data Output = DIN input (Loopback) 1: Reserved. Do not use.

**Page 0 / Register 34: Digital Interface Misc. Setting Register - 0x00 / 0x22**

BIT	Read/Write	Reset Value	DESCRIPTION
D7	R	0	Reserved. Write only default value.
D6	R	0	Reserved. Write only default value.
D5	R/W	0	I2C General Call Address Configuration 0: I2C General Call Address will be ignored 1: I2C General Call Address accepted
D4–D0	R	0 0000	Reserved. Write only default values.

**Page 0 / Register 35 - 36 Reserved- 0x00 / 0x23 - 0x24**

BIT	Read/Write	Reset Value	DESCRIPTION
D7–D0	R	0000 0000	Reserved. Write only zeros to these bits.

**Page 0 / Register 37: DAC Flag Register 1 - 0x00 / 0x25**

BIT	Read/Write	Reset Value	DESCRIPTION
D7	R	0	DAC Power Status Flag 0: DAC powered down 1: DAC powered up
D6	R	0	Reserved. Write only zeros to these bits.
D5	R	0	Headphone Driver (HPOUT) Power Status Flag 0: HPOUT driver powered down 1: HPOUT driver powered up
D4–D0	R	0 0000	Reserved. Write only zeros to these bits.

**Page 0 / Register 38: DAC Flag Register 2- 0x00 / 0x26**

BIT	Read/Write	Reset Value	DESCRIPTION
D7–D5	R	000	Reserved. Write only zeros to these bits.
D4	R	0	DAC PGA Status Flag 0: Gain applied in DAC PGA is not equal to Gain programmed in Control Register 1: Gain applied in DAC PGA is equal to Gain programmed in Control Register"
D3–D0	R	0000	Reserved. Write only zeros to these bits.

**Page 0 / Register 39 - 41: Reserved - 0x00 / 0x27-0x29**

BIT	Read/Write	Reset Value	DESCRIPTION
D7-D0	R	0000 0000	Reserved. Write only default values.

**Page 0 / Registers 42: Sticky Flag Register 1- 0x00 / 0x2A**

BIT	Read/Write	Reset Value	DESCRIPTION
D7	R	0	DAC Overflow Status. This sticky flag will self clear on read 0: No overflow in DAC 1: Overflow has happened in DAC since last read of this register"
D6	R	0	Reserved. Write only default value.
D5	R	0	Reserved. Write only default value.
D4-D0	R	0	Reserved. Write only default value.

**Page 0 / Registers 43: Interrupt Flags Register 1 - 0x00 / 0x2B**

BIT	Read/Write	Reset Value	DESCRIPTION
D7	R	0	DAC Overflow Status. 0: No overflow in DAC 1: Overflow condition is present in DAC at the time of reading the register"
D6	R	0	Reserved. Write only default value.
D5	R	0	Reserved. Write only default value.
D4-D0	R	0 0000	Reserved. Write only default value.

**Page 0 / Register 44: Sticky Flag Register 2 - 0x00 / 0x2C**

BIT	Read/Write	Reset Value	DESCRIPTION
D7	R	0	HPOUT Over Current Detect Flag 0: Over Current not detected on HPOUT 1: Over Current detected on HPOUT (will be cleared when the register is read)"
D6-D4	R	000	Reserved. Write only default values.
D3	R	0	Reserved. Write only default value.
D2	R	0	Reserved. Write only default value.
D1	R	0	Reserved. Write only default value.
D0	R	0	Reserved. Write only default value.

**Page 0 / Register 45: Reserved - 0x00 / 0x2D**

BIT	Read/Write	Reset Value	DESCRIPTION
D7-D0	R	0000 0000	Reserved. Write only default values.

**Page 0 / Register 46: Interrupt Flag Register 2 - 0x00 / 0x2E**

BIT	Read/Write	Reset Value	DESCRIPTION
D7	R	0	HPOUT Over Current Detect Flag 0: Over Current not detected on HPOUT 1: Over Current detected on HPOUT
D6-D4	R	0	Reserved. Write only default value.
D3	R	0	Reserved. Write only default value.
D2	R	0	Reserved. Write only default value.
D1	R	0	Reserved. Write only default value.
D0	R	0	Reserved. Write only default value.

**Page 0 / Register 47: Reserved - 0x00 / 0x2F**

BIT	Read/Write	Reset Value	DESCRIPTION
D7-D0	R	0000 0000	Reserved. Write only default value.

**Page 0 / Register 48: INT1 Control Register - 0x00 / 0x30**

BIT	Read/Write	Reset Value	DESCRIPTION
D7-D6	R	0	Reserved. Write only default value.
D5	R	0	Reserved. Write only default value.
D4	R	0	Reserved. Write only default value.
D3	R/W	0	INT1 Interrupt for Over Current Condition 0: Headphone Over Current condition will not generate a INT1 interrupt. 1: Headphone Over Current condition will generate a INT1 interrupt.
D2	R	0	Reserved. Write only default value.
D1	R	0	Reserved. Write only default value.
D0	R/W	0	INT1 pulse control 0: INT1 is active high interrupt of 1 pulse of approx. 2ms duration 1: INT1 is active high interrupt of multiple pulses, each of duration 2ms. To stop the pulse train, read Page-0, Reg-42, or 44

**Page 0 / Register 49: INT2 Interrupt Control Register - 0x00 / 0x31**

BIT	Read/Write	Reset Value	DESCRIPTION
D7-D6	R	0	Reserved. Write only default value.
D5	R	0	Reserved. Write only default value.
D4	R	0	Reserved. Write only default value.
D3	R/W	0	INT2 Interrupt for Over Current Condition 0: Headphone Over Current condition will not generate a INT2 interrupt. 1: Headphone Over Current condition will generate a INT2 interrupt.
D2	R	0	Reserved. Write only default value.
D1	R	0	Reserved. Write only default value.
D0	R/W	0	INT2 pulse control 0: INT2 is active high interrupt of 1 pulse of approx. 2ms duration 1: INT2 is active high interrupt of multiple pulses, each of duration 2ms. To stop the pulse train, read Page-0, Reg-42, or 44

**Page 0 / Register 50 and 51 Reserved - 0x00 / 0x32-0x33**

BIT	Read/Write	Reset Value	DESCRIPTION
D7-D0	R/W	0000 0000	Reserved. Write only Reset Values.

**Page 0 / Register 52: GPIO/DOUT Control Register - 0x00 / 0x34**

BIT	Read/Write	Reset Value	DESCRIPTION
D7-D6	R	00	Reserved. Write only default values.
D5-D2	R/W	0000	GPIO Control 0000: GPIO input/output disabled. 0001: GPIO input is used for secondary audio interface or clock input. Configure other registers to choose the functionality of GPIO input. 0010: GPIO is general purpose input 0011: GPIO is general purpose output 0100: GPIO output is CLKOUT 0101: GPIO output is INT1 0110: GPIO output is INT2 0111: GPIO output is 0 1000: GPIO output is secondary bit-clock for Audio Interface. 1001: GPIO output is secondary word-clock for Audio Interface. 1010: GPIO output is 0 1011-1101: Reserved. Do not use. 1110: GPIO output is DOUT for Audio Interface according to Register 53 programming. 1111: Reserved. Do not use.
D1	R	X	GPIO Input Pin state, used along with GPIO as general purpose input

**Page 0 / Register 52: GPIO/DOUT Control Register - 0x00 / 0x34 (continued)**

D0	R/W	0	GPIO as general purpose output control 0: GPIO pin is driven to '0' in general purpose output mode 1: GPIO pin is driven to '1' in general purpose output mode
----	-----	---	--

**Page 0 / Register 53: DOUT Function Control Register - 0x00 / 0x35**

BIT	Read/Write	Reset Value	DESCRIPTION
D7–D5	R	000	Reserved. Write only default values.
D4	R/W	1	DOUT Bus Keeper Control 0: DOUT Bus Keeper Enabled 1: DOUT Bus Keeper Disabled
D3–D1	R/W	001	DOUT MUX Control 000: DOUT disabled 001: DOUT disabled 010: DOUT is General Purpose Output 011: DOUT is CLKOUT 100: DOUT is INT1 101: DOUT is INT2 110: DOUT is Secondary BCLK 111: DOUT is Secondary WCLK
D0	R/W	0	DOUT as General Purpose Output 0: DOUT General Purpose Output Value = 0 1: DOUT General Purpose Output Value = 1

**Page 0 / Register 54: DIN Function Control Register - 0x00 / 0x36**

BIT	Read/Write	Reset Value	DESCRIPTION
D7–D3	R	0 0000	Reserved. Write only reserved values.
D2–D1	R/W	01	DIN function control 00: DIN pin is disabled 01: DIN is enabled for Primary Data Input or General Purpose Clock input 10: DIN is used as General Purpose Input 11: Reserved. Do not use
D0	R	X	Value of DIN input pin. To be used when for General Purpose Input

**Page 0 / Register 55: MISO Function Control Register - 0x00 / 0x37**

BIT	Read/Write	Reset Value	DESCRIPTION
D7–D5	R	000	Reserved. Write only reserved values.
D4–D1	R/W	0001	MISO function control 0000: MISO buffer disabled 0001: MISO is used for data output in SPI interface, is disabled for I2C interface 0010: MISO is General Purpose Output 0011: MISO is CLKOUT output 0100: MISO is INT1 output 0101: MISO is INT2 output 0110: Reserved 0111: Reserved 1000: MISO is Secondary Data Output for Audio Interface 1001: MISO is Secondary Bit Clock for Audio Interface 1010: MISO is Secondary Word Clock for Audio Interface 1011–1111: Reserved. Do not use
D0	R/W	0	Value to be driven on MISO pin when used as General Purpose Output 0: MISO General Purpose Output Value = 0 1: MISO General Purpose Output Value = 1

**Page 0 / Register 56: SCLK/DMDIN2 Function Control Register- 0x00 / 0x38**

BIT	Read/Write	Reset Value	DESCRIPTION
D7–D3	R	0 0000	Reserved. Write only default values.

**Page 0 / Register 56: SCLK/DMDIN2 Function Control Register- 0x00 / 0x38 (continued)**

D2–D1	R/W	01	SCLK function control 00: SCLK pin is disabled 01: SCLK pin is enabled for SPI clock in SPI Interface mode or when in I2C Interface enabled for Secondary Data Input or Secondary Bit Clock Input or Secondary Word Clock. 10: SCLK is enabled as General Purpose Input 11: Reserved. Do not use
D0	R	X	Value of SCLK input pin when used as General Purpose Input

**Page 0 / Register 57 - 59: Reserved - 0x00 / 0x39-0x3B**

BIT	Read/Write	Reset Value	DESCRIPTION
D7–D0	R	0000 0000	Reserved. Write only default values.

**Page 0 / Register 60: DAC Instruction Set - 0x00 / 0x3C**

BIT	Read/Write	Reset Value	DESCRIPTION
D7–D5	R	0	Reserved. Write only default value.
D4–D0	R/W	0 0001	0 0000: Reserved 0 0001: DAC Signal Processing Block PRB_P1 0 0010: DAC Signal Processing Block PRB_P2 0 0011: DAC Signal Processing Block PRB_P3 0 0100-1 1111: Reserved. Do not use

**Page 0 / Register 61-62: Reserved Registers - 0x00 / 0x3D - 0x3E**

BIT	Read/Write	Reset Value	DESCRIPTION
D7–D0	R	0000 0000	Reserved. Write only default values.

**Page 0 / Register 63: DAC Channel Setup Register 1 - 0x00 / 0x3F**

BIT	Read/Write	Reset Value	DESCRIPTION
D7	R/W	0	DAC Channel Power Control 0: DAC Channel Powered Down 1: DAC Channel Powered Up
D6	R	0	Reserved. Write only default value.
D5–D4	R/W	01	DAC Data path Control 00: DAC data is disabled 01: DAC data is picked from Left Channel Audio Interface Data 10: DAC data is picked from Right Channel Audio Interface Data 11: DAC data is picked from Mono Mix of Left and Right Channel Audio Interface Data
D3–D2	R	01	Reserved. Write only default values.
D1–D0	R/W	00	DAC Channel Volume Control's Soft-Step control 00: Soft-Stepping is 1 step per 1 DAC Word Clock 01: Soft-Stepping is 1 step per 2 DAC Word Clocks 10: Soft-Stepping is disabled 11: Reserved. Do not use

**Page 0 / Register 64: DAC Channel Setup Register 2 - 0x00 / 0x40**

BIT	Read/Write	Reset Value	DESCRIPTION
D7	R	0	Reserved. Write only default value.
D6-D4	R/W	000	DAC Auto Mute Control 000: Auto Mute disabled 001: DAC is auto muted if input data is DC for more than 100 consecutive inputs 010: DAC is auto muted if input data is DC for more than 200 consecutive inputs 011: DAC is auto muted if input data is DC for more than 400 consecutive inputs 100: DAC is auto muted if input data is DC for more than 800 consecutive inputs 101: DAC is auto muted if input data is DC for more than 1600 consecutive inputs 110: DAC is auto muted if input data is DC for more than 3200 consecutive inputs 111: DAC is auto muted if input data is DC for more than 6400 consecutive inputs

**Page 0 / Register 64: DAC Channel Setup Register 2 - 0x00 / 0x40 (continued)**

D3	R/W	1	DAC Channel Mute Control 0: DAC Channel not muted 1: DAC Channel muted
D2	R/W	1	Reserved. Write only default value.
D1-D0	R/W	00	Reserved. Write only default values.

**Page 0 / Register 65: DAC Channel Digital Volume Control Register - 0x00 / 0x41**

BIT	Read/Write	Reset Value	DESCRIPTION
D7-D0	R/W	0000 0000	DAC Channel Digital Volume Control Setting 0111 1111-0011 0001: Reserved. Do not use 0011 0000: Digital Volume Control = +24dB 0010 1111: Digital Volume Control = +23.5dB ... 0000 0001: Digital Volume Control = +0.5dB 0000 0000: Digital Volume Control = 0.0dB 1111 1111: Digital Volume Control = -0.5dB ... 1000 0010: Digital Volume Control = -63dB 1000 0001: Digital Volume Control = -63.5dB 1000 0000: Reserved. Do not use"

**Page 0 / Register 66-74: Reserved Register - 0x00 / 0x42 -0x4A**

BIT	Read/Write	Reset Value	DESCRIPTION
D7-D0	R	0000 0000	Reserved. Write only default values.

**Page 0 / Register 75: Reserved Register - 0x00 / 0x4B**

BIT	Read/Write	Reset Value	DESCRIPTION
D7-D0	R	1110 1110	Reserved. Write only default values.

**Page 0 / Register 76: Reserved Register - 0x00 / 0x4C**

BIT	Read/Write	Reset Value	DESCRIPTION
D7-D0	R	0001 0000	Reserved. Write only default values.

**Page 0 / Register 77: Reserved Register - 0x00 / 0x4D**

BIT	Read/Write	Reset Value	DESCRIPTION
D7-D0	R	1101 1000	Reserved. Write only default values.

**Page 0 / Register 78: Reserved Register - 0x00 / 0x4E**

BIT	Read/Write	Reset Value	DESCRIPTION
D7-D0	R	0111 1110	Reserved. Write only default values.

**Page 0 / Register 79: Reserved Register - 0x00 / 0x4F**

BIT	Read/Write	Reset Value	DESCRIPTION
D7-D0	R	1110 0011	Reserved. Write only default values.

**Page 0 / Register 80-81: Reserved register - 0x00 / 0x50 -0x51**

BIT	Read/Write	Reset Value	DESCRIPTION
D7-D0	R	0000 0000	Reserved. Write only default values.

**Page 0 / Register 82 - 127 Reserved Registers - 0x00 / 0x520x7F**

BIT	Read/Write	Reset Value	DESCRIPTION
D7-D0	R	0000 0000	Reserved. Write only default values.

## 6.1.2 Control Registers, Page 1: DAC Routing, Power-Controls and MISC Logic Related Programmabilities

### Page 1 / Register 0: Page Select Register - 0x01 / 0x00

BIT	Read/Write	Reset Value	DESCRIPTION
D7-D0	R/W	0000 0000	Page Select Register 0-255: Selects the Register Page for next read or write command. See the Table "Summary of Memory Map" for details.

### Page 1 / Registers 1: REF, POR and LDO BGAP Control Register - 0x01 / 0x01

Bit	Read/Write	Reset Value	Description
D7-D5	R	000	Reserved. Don't write any value other than Reset Values.
D4	R/W	0	Master Reference control 0: Master Reference powered down 1: Master Reference enabled
D3	R/W	0	POR power control 0: Do not power down the POR circuit 1: Power down the POR circuit
D2	R	0	Reserved. Don't write any value other than Reset Value.
D1	R/W	0	LDO bandgap power control 0: LDO bandgap not powered down 1: LDO bandgap powered down
D0	R	0	Reserved. Don't write any value other than Reset Value.

### Page 1 / Register 2: LDO Control Register - 0x01 / 0x02

Bit	Read/Write	Reset Value	Description
D7-D6	R	00	Reserved. Don't write any value other than Reset Value.
D5-D4	R/W	00	AVDD LDO Control 00: AVDD LDO output is nominally 1.8V 01: AVDD LDO output is nominally 1.6V 10: AVDD LDO output is nominally 1.7V 11: AVDD LDO output is nominally 1.5V
D3	R/W	1	0: PLL and HP Level Shifters powered up 1: PLL and HP Level Shifters powered down. This is to save leakage current issue when DVDD is powered up and AVDD is powered down
D2	R	1	Reserved. Don't write any value other than Reset Value.
D1	R	0	Short Circuit detect control 0: No Short Circuit detected in AVDD LDO 1: Short Circuit detected in AVDD LDO
D0	R	0	LDO Select 0: LDO_SEL pin is low 1: LDO_SEL pin is high

### Page 1 / Playback Configuration Register 1 - 0x01 / 0x03

Bit	Read/Write	Reset Value	Description
D7-D6	R	00	Reserved. Write only default values.
D5	R/W	0	0: DAC is enabled with low power mode 1: DAC is enabled with high performance mode
D4-D2	R/W	000	DAC PTM Control 000: DAC in mode PTM_P3, PTM_P4 001: DAC in mode PTM_P2 010: DAC in mode PTM_P1 011-111: Reserved. Do not use
D1-0	R	00	Reserved. Write only default values.

**Page 1 / Register 4 - 7: Reserved - 0x01 / 0x04 -0x07**

Bit	Read/Write	Reset Value	Description
D7 - D0	R	0000 0000	Reserved. Write only default values.

**Page 1 / Register 8: DAC PGA Control Register- 0x01 / 0x08**

Bit	Read/Write	Reset Value	Description
D7	R/W	0	0: Soft-stepping of all the PGA are enabled for DAC channel. 1: Soft-stepping of all the PGA are disabled for DAC channel.
D6	R/W	0	0: normal mode. 1: Soft-stepping time for all the PGA of DAC channel are doubled.
D5-D0	R	000000	Reserved. Don't write any values other than Reset Values.

**Page 1 / Register 9: Output Drivers, AINL, AINR, Control Register - 0x01 / 0x09**

Bit	Read/Write	Reset Value	Description
D7-D6	R	00	Reserved. Don't write any values other than Reset Values.
D5	R/W	0	0: HPL output is powered down 1: HPL output is powered up
D4-D2	R	00	Reserved. don't write any values other than Reset Values.
D1	R/W	0	0: AINL input is disabled 1: AINL input is enabled
D0	R/W	0	0: AINR input is disabled 1: AINR input is enabled

**Page 1 / Register 10: Common Mode Control Register - 0x01 / 0x0A**

Bit	Read/Write	Reset Value	Description
D7	R	0	Reserved. don't write any value other than Reset Value.
D6	R/W	0	0: Full Chip Common Mode is 0.9V 1: Full Chip Common Mode is 0.75V
D5-D4	R	0	Reserved. Don't write any value other than Reset Value.
D3	R	0	Reserved. Don't write any value other than Reset Value.
D2	R/W	0	0: Headphone output full drive ability 1: Headphone output half drive ability
D1-D0	R	00	Reserved. Don't write any values other than Reset Values.

**Page 1 / Register 11: HP Over Current Protection Configuration Register - 0x01 / 0x0B**

Bit	Read/Write	Reset Value	Description
D7-D5	R	000	Reserved. Write only default values.
D4	R/W	1	Reserved, Do not write '0'
D3-D1	R/W	000	000: No debounce is used for Over Current detection 001: Over Current detection is debounced by 8ms 010: Over Current detection is debounce by 16ms 011: Over Current detection is debounced by 32ms 100: Over Current detection is debounced by 64ms 101: Over Current detection is debounced by 128ms 110: Over Current detection is debounced by 256ms 111: Over Current detection is debounced by 512ms
D0	R/W	0	0: Output current will be limited if over current condition is detected 1: Output driver will be powered down if over current condition is detected

**Page 1 / Register 12: HP Routing Selection Register - 0x01 / 0x0C**

Bit	Read/Write	Reset Value	Description
-----	------------	-------------	-------------

**Page 1 / Register 12: HP Routing Selection Register - 0x01 / 0x0C (continued)**

D7-D4	R/W	0000	0000: No analog routing to SPK driver and HP driver 0001 - 0011 : Do not use 0100: AINR routed to Mixer P 0101: Do not use 0110: AINL/R differential routed to SPK driver through Mixer A and Mixer B 0111: Do no use 1000: AINL routed to Mixer A 1001: AINL/R differential routed to SPK driver through Mixer A and Mixer B 1010 -1011: Do not use 1100: AINL and AINR routed to Mixer A to HP driver 1101 - 1111: Do not use
D3	R/W	0	0: DAC output is not routed directly to HP driver. 1: DAC output is routed directly to HP driver.
D2	R/W	0	0: Mixer P is not connected to HP attenuator 1: Mixer P is connected to HP attenuator
D1	R/W	0	0: AINL attenuator is not routed to HP driver. 1: AINL attenuator is routed to HP driver.
D0	R/W	0	0: AINR attenuator is not routed to HP driver. 1: AINR attenuator is routed to HP driver.

**Page 1 / Register 13 - 15: Reserved - 0x01 / 0x0D - 0x0F**

Bit	Read/Write	Reset Value	Description
D7-D0	R	0000 0000	Reserved. Write only default values.

**Page 1 / Register 16: HP Driver Gain Setting Register - 0x01 / 0x10**

Bit	Read/Write	Reset Value	Description
D7	R	0	Reserved. Don't write any value other than Reset Value.
D6	R/W	1	0: HP driver is not muted 1: HP driver is muted
D5-D0	R/W	00 0000	10 0000 - 11 1001: Reserved. Do not use 11 1010: HP driver gain is -6dB (Note: It is not possible to mute HPR while programmed to -6dB) 11 1011: HP driver gain is -5dB 11 1100: HP driver gain is -4dB 11 1101: HP driver gain is -3dB ... 00 0000: HP driver gain is 0dB ... 00 0011: HP driver gain is 3dB 00 0100: HP driver gain is 4dB 00 0101: Hp driver gain is 5dB 00 0110: HP driver gain is 6dB ... 00 1100: HP driver gain is 12dB ... 01 0010: HP driver gain is 18dB ... 01 1000: HP driver gain is 24dB ... 01 1100: HP driver gain is 28dB 01 1101: HP driver gain is 29dB ... 00 1110 - 01 1111: Reserved. Do not use

**Page 1 / Register 17 - 19: Reserved - 0x01 / 0x11 - 0x13**

Bit	Read/Write	Reset Value	Description
D7 -D0	R	0000 0000	Reserved. Write only default values.

**Page 1 / Registers 20: Headphone Driver Startup Control Register - 0x01 / 0x14**

Bit	Read/Write	Reset Value	Description
-----	------------	-------------	-------------

**Page 1 / Registers 20: Headphone Driver Startup Control Register - 0x01 / 0x14 (continued)**

D7-D6	R/W	00	00: Soft-routing step time = 0ms 01: Soft-routing step time = 50ms 10: Soft-routing step time = 100ms 11: Soft-routing step time = 200ms
D5-D2	R/W	0000	0000: Slow power up of headphone amp's is disabled 0001: Headphone amps power up slowly in 0.5 time constants 0010: Headphone amps power up slowly in 0.625 time constants 0011; Headphone amps power up slowly in 0.725 time constants 0100: Headphone amps power up slowly in 0.875 time constants 0101: Headphone amps power up slowly in 1.0 time constants 0110: Headphone amps power up slowly in 2.0 time constants 0111: Headphone amps power up slowly in 3.0 time constants 1000: Headphone amps power up slowly in 4.0 time constants 1001: Headphone amps power up slowly in 5.0 time constants 1010: Headphone amps power up slowly in 6.0 time constants 1011: Headphone amps power up slowly in 7.0 time constants 1100: Headphone amps power up slowly in 8.0 time constants 1101: Headphone amps power up slowly in 16.0 time constants ( do not use for Rchg=25K) 1110: Headphone amps power up slowly in 24.0 time constants (do not use for Rchg=25K) 1111: Headphone amps power up slowly in 32.0 time constants (do not use for Rchg=25K) Note: Time constants assume 47µF decoupling cap
D1-D0	R/W	00	00: Headphone amps power up time is determined with 25K resistance 01: Headphone amps power up time is determined with 6K resistance 10: Headphone amps power up time is determined with 2K resistance 11: Reserved. Do not use

**Page 1 / Register 21: Reserved - 0x01 / 0x15**

Bit	Read/Write	Reset Value	Description
D7-D0	R	0000 0000	Reserved. Write only default values.

**Page 1 / Register 22: HP Volume Control Register - 0x01 / 0x16**

Bit	Read/Write	Reset Value	Description
D7	R	0	Reserved. Write only default value.

**Page 1 / Register 22: HP Volume Control Register - 0x01 / 0x16 (continued)**

D6-D0	R/W	000 0000	HP Volume Control
			000 0000: Volume Control = 0.0dB 000 0001: Volume Control = -0.5dB 000 0010: Volume Control = -1.0dB 000 0011: Volume Control = -1.5dB 000 0100: Volume Control = -2.0dB 000 0101: Volume Control = -2.5dB 000 0110: Volume Control = -3.0dB 000 0111: Volume Control = -3.5dB 000 1000: Volume Control = -4.0dB 000 1001: Volume Control = -4.5dB 000 1010: Volume Control = -5.0dB 000 1011: Volume Control = -5.5dB 000 1100: Volume Control = -6.0dB 000 1101: Volume Control = -6.5dB 000 1110: Volume Control = -7.0dB 000 1111: Volume Control = -7.5dB 001 0000: Volume Control = -8.0dB 001 0001: Volume Control = -8.5dB 001 0010: Volume Control = -9.0dB 001 0011: Volume Control = -9.5dB
			001 0100: Volume Control = -10.0dB 001 0101: Volume Control = -10.5dB 001 0110: Volume Control = -11.0dB 001 0111: Volume Control = -11.5dB 001 1000: Volume Control = -12.0dB 001 1001: Volume Control = -12.5dB 001 1010: Volume Control = -13.0dB 001 1011: Volume Control = -13.5dB 001 1100: Volume Control = -14.1dB 001 1101: Volume Control = -14.6dB 001 1110: Volume Control = -15.1dB 001 1111: Volume Control = -15.6dB 010 0000: Volume Control = -16.0dB 010 0001: Volume Control = -16.5dB 010 0010: Volume Control = -17.1dB 010 0011: Volume Control = -17.5dB 010 0100: Volume Control = -18.1dB 010 0101: Volume Control = -18.6dB 010 0110: Volume Control = -19.1dB 010 0111: Volume Control = -19.6dB
			010 1000: Volume Control = -20.1dB 010 1001: Volume Control = -20.6dB 010 1010: Volume Control = -21.1dB 010 1011: Volume Control = -21.6dB 010 1100: Volume Control = -22.1dB 010 1101: Volume Control = -22.6dB 010 1110: Volume Control = -23.1dB 010 1111: Volume Control = -23.6dB 011 0000: Volume Control = -24.1dB 011 0001: Volume Control = -24.6dB 011 0010: Volume Control = -25.1dB 011 0011: Volume Control = -25.6dB 011 0100: Volume Control = -26.1dB 011 0101: Volume Control = -26.6dB 011 0110: Volume Control = -27.1dB 011 0111: Volume Control = -27.6dB 011 1000: Volume Control = -28.1dB 011 1001: Volume Control = -28.6dB 011 1010: Volume Control = -29.1dB 011 1011: Volume Control = -29.6dB
			011 1100: Volume Control = -30.1dB 011 1101: Volume Control = -30.6dB 011 1110: Volume Control = -31.1dB 011 1111: Volume Control = -31.6dB 100 0000: Volume Control = -32.1dB 100 0001: Volume Control = -32.6dB 100 0010: Volume Control = -33.1dB 100 0011: Volume Control = -33.6dB 100 0100: Volume Control = -34.1dB 100 0101: Volume Control = -34.6dB 100 0110: Volume Control = -35.2dB 100 0111: Volume Control = -35.7dB 100 1000: Volume Control = -36.1dB 100 1001: Volume Control = -36.7dB 100 1010: Volume Control = -37.2dB 100 1011: Volume Control = -37.7dB 100 1100: Volume Control = -38.2dB 100 1101: Volume Control = -38.7dB 100 1110: Volume Control = -39.2dB 100 1111: Volume Control = -39.7dB
			101 0000: Volume Control = -40.2dB 101 0001: Volume Control = -40.7dB 101 0010: Volume Control = -41.2dB 101 0011: Volume Control = -41.8dB 101 0100: Volume Control = -42.1dB 101 0101: Volume Control = -42.7dB 101 0110: Volume Control = -43.2dB 101 0111: Volume Control = -43.8dB 101 1000: Volume Control = -44.3dB 101 1001: Volume Control = -44.8dB 101 1010: Volume Control = -45.2dB 101 1011: Volume Control = -45.8dB 101 1100: Volume Control = -46.2dB 101 1101: Volume Control = -46.7dB 101 1110: Volume Control = -47.4dB 101 1111: Volume Control = -47.9dB 110 0000: Volume Control = -48.2dB 110 0001: Volume Control = -48.7dB 110 0010: Volume Control = -49.3dB 110 0011: Volume Control = -50.0dB
			110 0100: Volume Control = -50.3dB 110 0101: Volume Control = -51.0dB 110 0110: Volume Control = -51.4dB 110 0111: Volume Control = -51.8dB 110 1000: Volume Control = -52.3dB 110 1001: Volume Control = -52.7dB 110 1010: Volume Control = -53.7dB 110 1011: Volume Control = -54.2dB 110 1100: Volume Control = -55.4dB 110 1101: Volume Control = -56.7dB 110 1110: Volume Control = -58.3dB 110 1111: Volume Control = -60.1dB 111 0000: Volume Control = -62.7dB 111 0001: Volume Control = -64.3dB 111 0010: Volume Control = -66.2dB 111 0011: Volume Control = -66.7dB 111 0100: Volume Control = -72.3dB 111 0101: Volume Control = Mute
			111 0110-111 1111: Reserved. Do not use

**Page 1 / Register 23: Reserved - 0x01 / 0x17**

Bit	Read/Write	Reset Value	Description
D7-D0	R	0000 0000	Reserved. Write only default values.

**Page 1 / Register 24: AINL Volume Control Register - 0x01 / 0x18**

Bit	Read/Write	Reset Value	Description
D7	R/W	0	0: Mixer P and Mixer M not forcedly enabled 1: Mixer P and Mixer M forcedly enabled Note: This a bit need to set "1" when not powered-on DAC and need to route AINL or AINR signal input to HP driver and SPK driver via Mixer P.

**Page 1 / Register 24: AINL Volume Control Register - 0x01 / 0x18 (continued)**

D6-D0	R/W	000 0000	AINL Volume Control
			000 0000: Volume Control = 0.0dB 000 0001: Volume Control = -0.5dB 000 0010: Volume Control = -1.0dB 000 0011: Volume Control = -1.5dB 000 0100: Volume Control = -2.0dB 000 0101: Volume Control = -2.5dB 000 0110: Volume Control = -3.0dB 000 0111: Volume Control = -3.5dB 000 1000: Volume Control = -4.0dB 000 1001: Volume Control = -4.5dB 000 1010: Volume Control = -5.0dB 000 1011: Volume Control = -5.5dB 000 1100: Volume Control = -6.0dB 000 1101: Volume Control = -6.5dB 000 1110: Volume Control = -7.0dB 000 1111: Volume Control = -7.5dB 001 0000: Volume Control = -8.0dB 001 0001: Volume Control = -8.5dB 001 0010: Volume Control = -9.0dB 001 0011: Volume Control = -9.5dB
			001 0100: Volume Control = -10.0dB 001 0101: Volume Control = -10.5dB 001 0110: Volume Control = -11.0dB 001 0111: Volume Control = -11.5dB 001 1000: Volume Control = -12.0dB 001 1001: Volume Control = -12.5dB 001 1010: Volume Control = -13.0dB 001 1011: Volume Control = -13.5dB 001 1100: Volume Control = -14.1dB 001 1101: Volume Control = -14.6dB 001 1110: Volume Control = -15.1dB 001 1111: Volume Control = -15.6dB 010 0000: Volume Control = -16.0dB 010 0001: Volume Control = -16.5dB 010 0010: Volume Control = -17.1dB 010 0011: Volume Control = -17.5dB 010 0100: Volume Control = -18.1dB 010 0101: Volume Control = -18.6dB 010 0110: Volume Control = -19.1dB 010 0111: Volume Control = -19.6dB
			010 1000: Volume Control = -20.1dB 010 1001: Volume Control = -20.6dB 010 1010: Volume Control = -21.1dB 010 1011: Volume Control = -21.6dB 010 1100: Volume Control = -22.1dB 010 1101: Volume Control = -22.6dB 010 1110: Volume Control = -23.1dB 010 1111: Volume Control = -23.6dB 011 0000: Volume Control = -24.1dB 011 0001: Volume Control = -24.6dB 011 0010: Volume Control = -25.1dB 011 0011: Volume Control = -25.6dB 011 0100: Volume Control = -26.1dB 011 0101: Volume Control = -26.6dB 011 0110: Volume Control = -27.1dB 011 0111: Volume Control = -27.6dB 011 1000: Volume Control = -28.1dB 011 1001: Volume Control = -28.6dB 011 1010: Volume Control = -29.1dB 011 1011: Volume Control = -29.6dB
			011 1100: Volume Control = -30.1dB 011 1101: Volume Control = -30.6dB 011 1110: Volume Control = -31.1dB 011 1111: Volume Control = -31.6dB 100 0000: Volume Control = -32.1dB 100 0001: Volume Control = -32.6dB 100 0010: Volume Control = -33.1dB 100 0011: Volume Control = -33.6dB 100 0100: Volume Control = -34.1dB 100 0101: Volume Control = -34.6dB 100 0110: Volume Control = -35.2dB 100 0111: Volume Control = -35.7dB 100 1000: Volume Control = -36.1dB 100 1001: Volume Control = -36.7dB 100 1010: Volume Control = -37.2dB 100 1011: Volume Control = -37.7dB 100 1100: Volume Control = -38.2dB 100 1101: Volume Control = -38.7dB 100 1110: Volume Control = -39.2dB 100 1111: Volume Control = -39.7dB
			101 0000: Volume Control = -40.2dB 101 0001: Volume Control = -40.7dB 101 0010: Volume Control = -41.2dB 101 0011: Volume Control = -41.8dB 101 0100: Volume Control = -42.1dB 101 0101: Volume Control = -42.7dB 101 0110: Volume Control = -43.2dB 101 0111: Volume Control = -43.8dB 101 1000: Volume Control = -44.3dB 101 1001: Volume Control = -44.8dB 101 1010: Volume Control = -45.2dB 101 1011: Volume Control = -45.8dB 101 1100: Volume Control = -46.2dB 101 1101: Volume Control = -46.7dB 101 1110: Volume Control = -47.4dB 101 1111: Volume Control = -47.9dB 110 0000: Volume Control = -48.2dB 110 0001: Volume Control = -48.7dB 110 0010: Volume Control = -49.3dB 110 0011: Volume Control = -50.0dB
			110 0100: Volume Control = -50.3dB 110 0101: Volume Control = -51.0dB 110 0110: Volume Control = -51.4dB 110 0111: Volume Control = -51.8dB 110 1000: Volume Control = -52.3dB 110 1001: Volume Control = -52.7dB 110 1010: Volume Control = -53.7dB 110 1011: Volume Control = -54.2dB 110 1100: Volume Control = -55.4dB 110 1101: Volume Control = -56.7dB 110 1110: Volume Control = -58.3dB 110 1111: Volume Control = -60.1dB 111 0000: Volume Control = -62.7dB 111 0001: Volume Control = -64.3dB 111 0010: Volume Control = -66.2dB 111 0011: Volume Control = -66.7dB 111 0100: Volume Control = -72.3dB 111 0101: Volume Control = Mute
			111 0110-111 1111: Reserved. Do not use

**Page 1 / Register 25: AINR Volume Control Register - 0x01 / 0x19**

Bit	Read/Write	Reset Value	Description
D7	R	0	Reserved. Write only default value.
D6-D0	R/W	000 0000	AINR Volume Control
			000 0000: Volume Control = 0.0dB 000 0001: Volume Control = -0.5dB 000 0010: Volume Control = -1.0dB 000 0011: Volume Control = -1.5dB 000 0100: Volume Control = -2.0dB 000 0101: Volume Control = -2.5dB 000 0110: Volume Control = -3.0dB 000 0111: Volume Control = -3.5dB 000 1000: Volume Control = -4.0dB 000 1001: Volume Control = -4.5dB 000 1010: Volume Control = -5.0dB 000 1011: Volume Control = -5.5dB 000 1100: Volume Control = -6.0dB 000 1101: Volume Control = -6.5dB 000 1110: Volume Control = -7.0dB 000 1111: Volume Control = -7.5dB 001 0000: Volume Control = -8.0dB 001 0001: Volume Control = -8.5dB 001 0010: Volume Control = -9.0dB 001 0011: Volume Control = -9.5dB 001 0100: Volume Control = -10.0dB 001 0101: Volume Control = -10.5dB 001 0110: Volume Control = -11.0dB 001 0111: Volume Control = -11.5dB 001 1000: Volume Control = -12.0dB 001 1001: Volume Control = -12.5dB 001 1010: Volume Control = -13.0dB 001 1011: Volume Control = -13.5dB 001 1100: Volume Control = -14.1dB 001 1101: Volume Control = -14.6dB 010 1000: Volume Control = -20.1dB 010 1001: Volume Control = -20.6dB 010 1010: Volume Control = -21.1dB 010 1011: Volume Control = -21.6dB 010 1100: Volume Control = -22.1dB 010 1101: Volume Control = -22.6dB 010 1110: Volume Control = -23.1dB 010 1111: Volume Control = -23.6dB 011 0000: Volume Control = -24.1dB 011 0001: Volume Control = -24.6dB 011 0010: Volume Control = -25.1dB 011 0011: Volume Control = -25.6dB 011 0100: Volume Control = -26.1dB 011 0101: Volume Control = -26.6dB 011 0110: Volume Control = -27.1dB 011 0111: Volume Control = -27.6dB 011 1000: Volume Control = -28.1dB 011 1001: Volume Control = -28.6dB 011 1010: Volume Control = -29.1dB 011 1011: Volume Control = -29.6dB 011 1100: Volume Control = -30.1dB 011 1101: Volume Control = -30.6dB 011 1110: Volume Control = -31.1dB 011 1111: Volume Control = -31.6dB 100 0000: Volume Control = -32.1dB 100 0001: Volume Control = -32.6dB 100 0010: Volume Control = -33.1dB 100 0011: Volume Control = -33.6dB 100 0100: Volume Control = -34.1dB 100 0101: Volume Control = -34.6dB 100 0110: Volume Control = -35.2dB 100 0111: Volume Control = -35.7dB 100 1000: Volume Control = -36.1dB 100 1001: Volume Control = -36.7dB 100 1010: Volume Control = -37.2dB 100 1011: Volume Control = -37.7dB 100 1100: Volume Control = -38.2dB 100 1101: Volume Control = -38.7dB 100 1110: Volume Control = -39.2dB 100 1111: Volume Control = -39.7dB 101 0000: Volume Control = -40.2dB 101 0001: Volume Control = -40.7dB 101 0010: Volume Control = -41.2dB 101 0011: Volume Control = -41.8dB 101 0100: Volume Control = -42.1dB 101 0101: Volume Control = -42.7dB 101 0110: Volume Control = -43.2dB 101 0111: Volume Control = -43.8dB 101 1000: Volume Control = -44.3dB 101 1001: Volume Control = -44.8dB 101 1010: Volume Control = -45.2dB 101 1011: Volume Control = -45.8dB 101 1100: Volume Control = -46.2dB 101 1101: Volume Control = -46.7dB 101 1110: Volume Control = -47.4dB 101 1111: Volume Control = -47.9dB 110 0000: Volume Control = -48.2dB 110 0001: Volume Control = -48.7dB 110 0010: Volume Control = -49.3dB 110 0011: Volume Control = -50.0dB 110 0100: Volume Control = -50.3dB 110 0101: Volume Control = -51.0dB 110 0110: Volume Control = -51.4dB 110 0111: Volume Control = -51.8dB 110 1000: Volume Control = -52.3dB 110 1001: Volume Control = -52.7dB 110 1010: Volume Control = -53.7dB 110 1011: Volume Control = -54.2dB 110 1100: Volume Control = -55.4dB 110 1101: Volume Control = -56.7dB 110 1110: Volume Control = -58.3dB 110 1111: Volume Control = -60.1dB 111 0000: Volume Control = -62.7dB 111 0001: Volume Control = -64.3dB 111 0010: Volume Control = -66.2dB 111 0011: Volume Control = -66.7dB 111 0100: Volume Control = -72.3dB 111 0101: Volume Control = Mute

**Page 1 / Register 25: AINR Volume Control Register - 0x01 / 0x19 (continued)**

			111 0110-111 1111: Reserved. Do not use
--	--	--	---

**Page 1 / Register 26 - 44: Reserved - 0x01 / 0x1A - 0x2C**

Bit	Read/Write	Reset Value	Description
D7-D0	R	0000 0000	Reserved. Write only default values

**Page 1 / Register 45: Speaker Amplifier Control 1 - 0x01 / 0x2D**

Bit	Read/Write	Reset Value	Description
D7-D2	R	0000 00	Reserved. Write only Reset Values.
D1	R/W	0	Speaker Driver Power 0: SPK output driver is powered down 1: SPK output driver is powered up
D0	R	0	Reserved. Write only default values.

**Page 1 / Register 46: Speaker Volume Control 1 - 0x01 / 0x2E**

Bit	Read/Write	Reset Value	Description
D7	R	0	Reserved. Write only Reset Values.

**Page 1 / Register 46: Speaker Volume Control 1 - 0x01 / 0x2E (continued)**

D6-D0	R/W	000 0000	SPK Driver Volume Control:
			000 0000: Volume Control = 0.00 dB 000 0001: Volume Control = -0.5 dB 000 0010: Volume Control = -1.0 dB 000 0011: Volume Control = -1.5 dB 000 0100: Volume Control = -2.0 dB 000 0101: Volume Control = -2.5 dB 000 0110: Volume Control = -3.0 dB 000 0111: Volume Control = -3.5 dB 000 1000: Volume Control = -4.0 dB 000 1001: Volume Control = -4.5 dB 000 1010: Volume Control = -5.0 dB 000 1011: Volume Control = -5.5 dB 000 1100: Volume Control = -6.0 dB 000 1101: Volume Control = -6.5 dB 000 1110: Volume Control = -7.0 dB 000 1111: Volume Control = -7.5 dB 001 0000: Volume Control = -8.0 dB 001 0001: Volume Control = -8.5 dB 001 0010: Volume Control = -9.0 dB 001 0011: Volume Control = -9.5 dB
			001 0100: Volume Control = -10.0 dB 001 0101: Volume Control = -10.5 dB 001 0110: Volume Control = -11.0 dB 001 0111: Volume Control = -11.5 dB 001 1000: Volume Control = -12.0 dB 001 1001: Volume Control = -12.5 dB 001 1010: Volume Control = -13.0 dB 001 1011: Volume Control = -13.5 dB 001 1100: Volume Control = -14.1 dB 001 1101: Volume Control = -14.6 dB
			010 1000: Volume Control = -20.1 dB 010 1001: Volume Control = -20.6 dB 010 1010: Volume Control = -21.1 dB 010 1011: Volume Control = -21.6 dB 010 1100: Volume Control = -22.1 dB 010 1101: Volume Control = -22.6 dB 010 1110: Volume Control = -23.1 dB 010 1111: Volume Control = -23.6 dB 011 0000: Volume Control = -24.1 dB 011 0001: Volume Control = -24.6 dB
			011 0010: Volume Control = -25.1 dB 011 0011: Volume Control = -25.6 dB 011 0100: Volume Control = -26.1 dB 011 0101: Volume Control = -26.6 dB 011 0110: Volume Control = -27.1 dB 011 0111: Volume Control = -27.6 dB 011 1000: Volume Control = -28.1 dB 011 1001: Volume Control = -28.6 dB 011 1010: Volume Control = -29.1 dB 011 1011: Volume Control = -29.6 dB
			011 1100: Volume Control = -30.1 dB 011 1101: Volume Control = -30.6 dB 011 1110: Volume Control = -31.1 dB 011 1111: Volume Control = -31.6 dB 100 0000: Volume Control = -32.1 dB 100 0001: Volume Control = -32.7 dB 100 0010: Volume Control = -33.1 dB 100 0011: Volume Control = -33.6 dB 100 0100: Volume Control = -34.1 dB 100 0101: Volume Control = -34.6 dB
			100 0110: Volume Control = -35.2 dB 100 0111: Volume Control = -35.7 dB 100 1000: Volume Control = -36.1 dB 100 1001: Volume Control = -36.7 dB 100 1010: Volume Control = -37.1 dB 100 1011: Volume Control = -37.7 dB 100 1100: Volume Control = -38.2 dB 100 1101: Volume Control = -38.7 dB 100 1110: Volume Control = -39.2 dB 100 1111: Volume Control = -39.7 dB
			101 0000: Volume Control = -40.2 dB 101 0001: Volume Control = -40.7 dB 101 0010: Volume Control = -41.2 dB 101 0011: Volume Control = -41.8 dB 101 0100: Volume Control = -42.1 dB 101 0101: Volume Control = -42.7 dB 101 0110: Volume Control = -43.2 dB 101 0111: Volume Control = -43.8 dB 101 1000: Volume Control = -44.3 dB 101 1001: Volume Control = -44.8 dB
			101 1010: Volume Control = -45.2 dB 101 1011: Volume Control = -45.8 dB 101 1100: Volume Control = -46.2 dB 101 1101: Volume Control = -46.7 dB 101 1110: Volume Control = -47.4 dB 101 1111: Volume Control = -47.9 dB 110 0000: Volume Control = -48.2 dB 110 0001: Volume Control = -48.7 dB 110 0010: Volume Control = -49.3 dB 110 0011: Volume Control = -50.0 dB
			110 0100: Volume Control = -50.3 dB 110 0101: Volume Control = -51.0 dB 110 0110: Volume Control = -51.4 dB 110 0111: Volume Control = -51.8 dB 110 1000: Volume Control = -52.3 dB 110 1001: Volume Control = -52.7 dB 110 1010: Volume Control = -53.7 dB 110 1011: Volume Control = -54.2 dB 110 1100: Volume Control = -55.4 dB 110 1101: Volume Control = -56.7 dB 110 1110: Volume Control = -58.3 dB 110 1111: Volume Control = -60.2 dB 111 0000: Volume Control = -62.7 dB 111 0001: Volume Control = -64.3 dB 111 0010: Volume Control = -66.2 dB 111 0011: Volume Control = -68.7 dB 111 0100: Volume Control = -72.3 dB 111 0101 - 1111110: Reserved 111 1111: Mute

**Page 1 / Register 47: Reserved - 0x01 / 0x2F**

Bit	Read/Write	Reset Value	Description
D7-D0	R	0000 0000	Reserved. Write only default values.

**Page 1 / Register 48: Speaker Amplifier Volume Control 2 - 0x01 / 0x30**

Bit	Read/Write	Reset Value	Description
D7	R	0	Reserved. Write only Reset Values.
D6-D4	R/W	000	Left Speaker Amplifier (SPK) Volume Control: 000: SPK Driver is Muted (Default) 001: SPK Driver Volume = 6 dB 010: SPK Driver Volume = 12 dB 011: SPK Driver Volume = 18 dB 100: SPK Driver Volume = 24 dB 101: SPK Driver Volume = 32 dB 110 - 111: Reserved
D3-D0	R	0000	Reserved. Write only Reset Values.

**Page 1 / Register 49 - 62: Reserved - 0x01 / 0x31 - 0x3E**

Bit	Read/Write	Reset Value	Description
D7-D0	R	0000 0000	Reserved. Write only default values.

**Page 1 / Register 63: DAC Analog Gain Control Flag Register - 0x01 / 0x3F**

Bit	Read/Write	Reset Value	Description
D7	R	0	HP Gain Flag 0: Applied Gain is not equal to Programmed Gain 1: Applied Gain is equal to Programmed Gain
D6-D4	R	000	Reserved. Write only default values
D3	R	0	AIN1L Mix PGA for HP Applied Gain Flag 0: Applied Volume is not equal to Programmed Volume 1: Applied Volume is equal to Programmed Volume
D2	R	0	Reserved. Write only default values
D1	R	0	Left Mixer PGA for AINL Volume Flag 0: Applied Volume is not equal to Programmed Volume 1: Applied Volume is equal to Programmed Volume
D0	R	0	Right Mixer PGA for AINR Volume Flag 0: Applied Volume is not equal to Programmed Volume 1: Applied Volume is equal to Programmed Volume

**Page 1 / Register 64 - 80: Reserved - 0x01 / 0x40 -0x50**

Bit	Read/Write	Reset Value	Description
D7-D0	R	0000 0000	Reserved. Write only default values.

**Page 1 / Register 81: Speaker Amplifier Delay Control Register - 0x01 / 0x51**

Bit	Read/Write	Reset Value	Description
D7	R/W	0	0: Speaker power-on delay block is not bypassed 1: Speaker power-on delay block is bypassed
D6-D5	R/W	00	00: Speaker power-on delay is 512 ramp cycles 01: Speaker power-on delay is 1024 ramp cycles 10: Speaker power-on delay is 256 ramp cycles 11: Speaker power-on delay is 16 ramp cycles
D4-D0	R	0 0000	Reserved. Write only Reset Values.

**Page 1 / Register 82: Reserved - 0x01 / 0x52**

Bit	Read/Write	Reset Value	Description
-----	------------	-------------	-------------

**Page 1 / Register 82: Reserved - 0x01 / 0x52 (continued)**

D7-D0	R	0000 0000	Reserved. Write only Reset Values.
-------	---	-----------	------------------------------------

**Page 1 / Register 83: Reserved - 0x01 / 0x53**

Bit	Read/Write	Reset Value	Description
D7-D0	R	0000 0000	Reserved. Write only Reset Values.

**Page 1 / Register 84 - 121: Reserved - 0x01 / 0x54 - 0x79**

Bit	Read/Write	Reset Value	Description
D7-D0	R	0000 0000	Reserved. Write only Reset Values.

**Page 1 / Register 122: Reference Power Up Delay - 0x01 / 0x7A**

Bit	Read/Write	Reset Value	Description
D7-D3	R	0 0000	Reserved. Write only default values.
D2-D0	R/W	000	Reference Power Up configuration 000: Reference will power up slowly when analog blocks are powered up 001: Reference will power up in 40ms when analog blocks are powered up 010: Reference will power up in 80ms when analog blocks are powered up 011: Reference will power up in 120ms when analog blocks are powered up 100: Force power up of reference. Power up will be slow 101: Force power up of reference. Power up time will be 40ms 110: Force power up of reference. Power up time will be 80ms 111: Force power up of reference. Power up time will be 120ms

**Page 1 / Register 123 - 127: Reserved - 0x01 / 0x7A -0x7F**

Bit	Read/Write	Reset Value	Description
D7-D0	R	0000 0000	Reserved. Write only Reset Values.

### 6.1.3 Page 2 - 43: Reserved Register

#### Page 2 - 43 / Register 0 - 127: Reserved Register - 0x02 - 0x2B / 0x00 -0x7F

BIT	Read/Write	Reset Value	DESCRIPTION
D7–D0	R	XXXX XXXX	Reserved Register. Don't write any values.

### 6.1.4 Page 44: DAC Programmable Coefficients RAM

#### Page 44 / Register 0: Page Select Register - 0x2C / 0x00

BIT	Read/Write	Reset Value	DESCRIPTION
D7–D0	R/W	0000 0000	Page Select Register 0-255: Selects the Register Page for next read or write command. See the Table "Summary of Memory Map" for details.

#### Page 44 / Register 1: DAC Adaptive Filter Configuration Register - 0x2C / 0x01

BIT	Read/Write	Reset Value	DESCRIPTION
D7–D3	R	0000 0	Reserved. Write only default values.
D2	R/W	0	DAC Adaptive Filtering Control 0: Adaptive Filtering disabled for DAC 1: Adaptive Filtering enabled for DAC
D1	R	0	DAC Adaptive Filter Buffer Control Flag 0: In adaptive filter mode, DAC accesses DAC Coefficient Buffer-A and control interface accesses DAC Coefficient Buffer-B 1: In adaptive filter mode, DAC accesses DAC Coefficient Buffer-B and control interface accesses DAC Coefficient Buffer-A
D0	R/W	0	DAC Adaptive Filter Buffer Switch control 0: DAC Coefficient Buffers will not be switched at next frame boundary 1: DAC Coefficient Buffers will be switched at next frame boundary, if in adaptive filtering mode. This will self clear on switching.

#### Page 44 / Register 2 - 7: Reserved Register - 0x2C / 0x02 - 0x07

BIT	Read/Write	Reset Value	DESCRIPTION
D7–D0	R	XXXX XXXX	Reserved Register. Don't write any values.

#### Page 44 / Register 8 - 127: DAC Coefficient Buffer-A C(0:29) - 0x2C / 0x08 - 0x7F

BIT	Read/Write	Reset Value	DESCRIPTION
D7–D0	R/W	0000 0000	24-bit coefficients C0 through C29 of DAC Coefficient Buffer-A. See the Table "DAC Coefficient Buffer A Map" for details. When Page-44, Reg-01d, D2='0' (Adaptive filtering disabled) the read write access to these registers is allowed only when DAC channel is powered down.

Default values shown for this page only become valid 100  $\mu$ s following a hardware or software reset.

### 6.1.5 Page 45 - 52: DAC Programmable Coefficients RAM

#### Page 45 - 52 / Register 0: Page Select Register - 0x2D - 0x34 / 0x00

BIT	Read/Write	Reset Value	DESCRIPTION
D7–D0	R/W	0000 0000	Page Select Register 0-255: Selects the Register Page for next read or write command. See the Table "Summary of Memory Map" for details.

#### Page 45 - 52 / Register 1 - 7: Reserved Register - 0x2D - 0x34 / 0x01 - 0x07

BIT	Read/Write	Reset Value	DESCRIPTION
D7–D0	R	XXXX XXXX	Reserved Register. Don't write any values.

#### Page 45 - 52 / Register 8 - 127: DAC Coefficients Buffer-A C(30:255) - 0x2D - 0x34 / 0x08 -0x7F

BIT	Read/Write	Reset Value	DESCRIPTION
D7–D0	R/W	0000 0000	24-bit coefficients C0 through C29 of DAC Coefficient Buffer-A. See the Table "DAC Coefficient Buffer A Map" for details. When Page-44, Reg-01d, D2='0' (Adaptive filtering disabled) the read write access to these registers is allowed only when DAC channel is powered down.

Default values shown for this page only become valid 100  $\mu$ s following a hardware or software reset.

### 6.1.6 Page 53 - 61: Reserved Register

#### Page 53 - 61 / Register 0 - 127: Reserved Register - 0x35 - 0x3D / 0x00 -0x7F

BIT	Read/Write	Reset Value	DESCRIPTION
D7–D0	R	XXXX XXXX	Reserved Register. Don't write any values.

### 6.1.7 Page 62 - 70: DAC Programmable Coefficients RAM

#### Page 62 - 70 / Register 0: Page Select Register - 0x3E - 0x46 / 0x00

BIT	Read/Write	Reset Value	DESCRIPTION
D7–D0	R/W	0000 0000	Page Select Register 0-255: Selects the Register Page for next read or write command. See the Table "Summary of Memory Map" for details.

Default values shown for this page only become valid 100  $\mu$ s following a hardware or software reset.

#### Page 62 - 70 / Register 1 - 7: Reserved - 0x3E - 0x46 / 0x01 - 0x07

BIT	Read/Write	Reset Value	DESCRIPTION
D7–D0	R	XXXX XXXX	Reserved Register. Don't write any values.

#### Page 62 - 70 / Register 8 -127: DAC Coefficients Buffer-B C(0:255) - 0x3E - 0x46 / 0x08 - 0x7F

BIT	Read/Write	Reset Value	DESCRIPTION
D7–D0	R/W	0000 0000	24-bit coefficients of DAC Coefficient Buffer-B. See the "DAC Coefficient Buffer B Map" for details. When Page-44, Reg-01d, D2='0' (Adaptive filtering disabled) the read write access to these registers is allowed only when DAC channel is powered down.

Default values shown for this page only become valid 100  $\mu$ s following a hardware or software reset.

### 6.1.8 Pages 71 – 255: Reserved Register

#### Pages 71 – 255 / Register 0 - 127 : Reserved - 0x47 - 0xFF / 0x00 -0x7F

BIT	Read/Write	Reset Value	DESCRIPTION
D7–D0	R	XXXX XXXX	Reserved Register. Don't write any values.

## 6.1.9 DAC Coefficients A+B

**Table 6-2. DAC Coefficient Buffer-A Map**

Coef No	Page No	Base Register	Base Register + 0	Base Register + 1	Base Register + 2	Base Register + 3
C0	44	8	Coef(23:16)	Coef(15:8)	Coef(7:0)	Reserved.
C1	44	12	Coef(23:16)	Coef(15:8)	Coef(7:0)	Reserved.
	..	..	..	..	..	..
C29	44	124	Coef(23:16)	Coef(15:8)	Coef(7:0)	Reserved.
C30	45	8	Coef(23:16)	Coef(15:8)	Coef(7:0)	Reserved.
	..	..	..	..	..	..
C59	45	124	Coef(23:16)	Coef(15:8)	Coef(7:0)	Reserved.
C60	46	8	Coef(23:16)	Coef(15:8)	Coef(7:0)	Reserved.
	..	..	..	..	..	..
C89	46	124	Coef(23:16)	Coef(15:8)	Coef(7:0)	Reserved.
C90	47	8	Coef(23:16)	Coef(15:8)	Coef(7:0)	Reserved.
	..	..	..	..	..	..
C119	47	124	Coef(23:16)	Coef(15:8)	Coef(7:0)	Reserved.
C120	48	8	Coef(23:16)	Coef(15:8)	Coef(7:0)	Reserved.
	..	..	..	..	..	..
C149	48	124	Coef(23:16)	Coef(15:8)	Coef(7:0)	Reserved.
C150	49	8	Coef(23:16)	Coef(15:8)	Coef(7:0)	Reserved.
	..	..	..	..	..	..
C179	49	124	Coef(23:16)	Coef(15:8)	Coef(7:0)	Reserved.
C180	50	8	Coef(23:16)	Coef(15:8)	Coef(7:0)	Reserved.
	..	..	..	..	..	..
C209	50	124	Coef(23:16)	Coef(15:8)	Coef(7:0)	Reserved.
C210	51	8	Coef(23:16)	Coef(15:8)	Coef(7:0)	Reserved.
	..	..	..	..	..	..
C239	51	124	Coef(23:16)	Coef(15:8)	Coef(7:0)	Reserved.
C240	52	8	Coef(23:16)	Coef(15:8)	Coef(7:0)	Reserved.
	..	..	..	..	..	..
C255	52	68	Coef(23:16)	Coef(15:8)	Coef(7:0)	Reserved.

**Table 6-3. DAC Coefficient Buffer-B Map**

Coef No	Page No	Base Register	Base Register + 0	Base Register + 1	Base Register + 2	Base Register + 3
C0	62	8	Coef(23:16)	Coef(15:8)	Coef(7:0)	Reserved.
C1	62	12	Coef(23:16)	Coef(15:8)	Coef(7:0)	Reserved.
	..	..	..	..	..	..
C29	62	124	Coef(23:16)	Coef(15:8)	Coef(7:0)	Reserved.
C30	63	8	Coef(23:16)	Coef(15:8)	Coef(7:0)	Reserved.
	..	..	..	..	..	..
C59	63	124	Coef(23:16)	Coef(15:8)	Coef(7:0)	Reserved.
C60	64	8	Coef(23:16)	Coef(15:8)	Coef(7:0)	Reserved.
	..	..	..	..	..	..
C89	64	124	Coef(23:16)	Coef(15:8)	Coef(7:0)	Reserved.
C90	65	8	Coef(23:16)	Coef(15:8)	Coef(7:0)	Reserved.
	..	..	..	..	..	..
C119	65	124	Coef(23:16)	Coef(15:8)	Coef(7:0)	Reserved.
C120	66	8	Coef(23:16)	Coef(15:8)	Coef(7:0)	Reserved.
	..	..	..	..	..	..
C149	66	124	Coef(23:16)	Coef(15:8)	Coef(7:0)	Reserved.
C150	67	8	Coef(23:16)	Coef(15:8)	Coef(7:0)	Reserved.
	..	..	..	..	..	..
C179	67	124	Coef(23:16)	Coef(15:8)	Coef(7:0)	Reserved.
C180	68	8	Coef(23:16)	Coef(15:8)	Coef(7:0)	Reserved.
	..	..	..	..	..	..
C209	68	124	Coef(23:16)	Coef(15:8)	Coef(7:0)	Reserved.
C210	69	8	Coef(23:16)	Coef(15:8)	Coef(7:0)	Reserved.
	..	..	..	..	..	..
C239	69	124	Coef(23:16)	Coef(15:8)	Coef(7:0)	Reserved.
C240	70	8	Coef(23:16)	Coef(15:8)	Coef(7:0)	Reserved.
	..	..	..	..	..	..
C255	70	68	Coef(23:16)	Coef(15:8)	Coef(7:0)	Reserved.

### 6.1.10 DAC Defaults

**Table 6-4. Default values of DAC Coefficients in Buffers A and B**

DAC Buffer-A,B Coefficients	Default Value at Reset
C0	00000000H
C1	7FFFFFFFH
C2,...,C5	00000000H
C6	7FFFFFFFH
C7,...,C10	00000000H
C11	7FFFFFF00H
C12,...,C15	00000000H
C16	7FFFFFFFH
C17,...,C20	00000000H
C21	7FFFFFFFH
C22,...,C25	00000000H
C26	7FFFFFFFH
C27,...,C30	00000000H
C31,C32	00000000H
C33	7FFFFFFFH
C34,...,C37	00000000H
C38	7FFFFFFFH
C39,...,C42	00000000H
C43	7FFFFFFFH
C44,...,C47	00000000H
C48	7FFFFFFFH
C49,...,C52	00000000H
C53	7FFFFFFFH
C54,...,C57	00000000H
C58	7FFFFFF00H
C59,...,C64	00000000H
C65	7FFFFFFFH
C66,C67	00000000H
C68	7FFFFFFFH
C69,C70	00000000H
C71	7FF70000H
C72	10090000H
C73	7FEF0000H
C74,C75	00110000H
C76	7FDE0000H
C77,...,C255	00000000H

## Revision History

---



NOTE: Page numbers for previous revisions may differ from page numbers in the current version.

<b>Changes from Revision B (July 2023) to Revision C (November 2023)</b>	<b>Page</b>
<ul style="list-style-type: none"><li>Updated step <a href="#">DAC Setup</a> Step 2 to show proper power up sequence enabling SPK output at the end once DAC is enabled.....</li></ul>	<b>31</b>
<hr/>	
<b>Changes from Revision A (March 2021) to Revision B (July 2023)</b>	<b>Page</b>
<ul style="list-style-type: none"><li>Updated <a href="#">Chapter 2 Description</a> .....</li></ul>	<b>9</b>
<ul style="list-style-type: none"><li>Updated <a href="#">Section 3.4.8.2 Speaker Driver</a>. Full device reset is not required to recover from short circuit event, show instructions for power stage reset only.....</li></ul>	<b>27</b>
<ul style="list-style-type: none"><li>Added the last paragraph in <a href="#">Section 4.1 Power On Sequence</a> to highlight the importance of disabling SPK output whenever the input clocks are disabled.....</li></ul>	<b>53</b>
<ul style="list-style-type: none"><li>Updated scripts in <a href="#">Section 5.1</a>, <a href="#">Section 5.3</a>, <a href="#">Section 5.5</a> and <a href="#">Section 5.6</a> to include the correct power sequence enabling SPK output at the end once DAC is enabled.....</li></ul>	<b>59</b>

---

## IMPORTANT NOTICE AND DISCLAIMER

TI PROVIDES TECHNICAL AND RELIABILITY DATA (INCLUDING DATA SHEETS), DESIGN RESOURCES (INCLUDING REFERENCE DESIGNS), APPLICATION OR OTHER DESIGN ADVICE, WEB TOOLS, SAFETY INFORMATION, AND OTHER RESOURCES "AS IS" AND WITH ALL FAULTS, AND DISCLAIMS ALL WARRANTIES, EXPRESS AND IMPLIED, INCLUDING WITHOUT LIMITATION ANY IMPLIED WARRANTIES OF MERCHANTABILITY, FITNESS FOR A PARTICULAR PURPOSE OR NON-INFRINGEMENT OF THIRD PARTY INTELLECTUAL PROPERTY RIGHTS.

These resources are intended for skilled developers designing with TI products. You are solely responsible for (1) selecting the appropriate TI products for your application, (2) designing, validating and testing your application, and (3) ensuring your application meets applicable standards, and any other safety, security, regulatory or other requirements.

These resources are subject to change without notice. TI grants you permission to use these resources only for development of an application that uses the TI products described in the resource. Other reproduction and display of these resources is prohibited. No license is granted to any other TI intellectual property right or to any third party intellectual property right. TI disclaims responsibility for, and you will fully indemnify TI and its representatives against, any claims, damages, costs, losses, and liabilities arising out of your use of these resources.

TI's products are provided subject to [TI's Terms of Sale](#) or other applicable terms available either on [ti.com](https://www.ti.com) or provided in conjunction with such TI products. TI's provision of these resources does not expand or otherwise alter TI's applicable warranties or warranty disclaimers for TI products.

TI objects to and rejects any additional or different terms you may have proposed.

Mailing Address: Texas Instruments, Post Office Box 655303, Dallas, Texas 75265  
Copyright © 2023, Texas Instruments Incorporated

## Looking for pricing, stock, or lifecycle information?

Click below to explore more details on WIN SOURCE:

 [View TAS2505TRGERQ1 on WIN SOURCE](#)

 [Texas Instruments](#) Information

## Optimize Your Supply Chain with WIN SOURCE Solutions

-  Global Sourcing Solution
-  Obsolete Management
-  Cost Control Management
-  Shortage Management
-  Alternative Solution
-  Excess Inventory Management