

STRUCTURE	Silicon Monolithic Integrated Circuit		
TYPE	B A 5 9 1 2 B F P		
PRODUCT SERIES	BTL DRIVER for CD-ROM		
PACKAGE OUTLINES	Figure 1 ( Plastic Mold )	POWER DISSIPATION	Figure 2
BLOCK DIAGRAM	Figure 3	APPLICATION	Figure 4
TEST CIRCUIT	Figure 5	SWITCH TABLE	Table 1
FUNCTIONS	<ul style="list-style-type: none"> <li>① 2ch BTL Driver.</li> <li>② Available in a HSOP25 package</li> <li>③ Wide dynamic range.</li> <li>④ Built-in thermal shutdown circuit.</li> <li>⑤ Includes two general purpose operational amplifiers.</li> <li>⑥ Built-in mute (ch1,2) circuit and stand by mode(by muting both channel).</li> <li>⑦ Voltage supply (Pre Vcc, CH1 Pow Vcc, CH2 Pow Vcc) are separated.</li> </ul>		

ABSOLUTE MAXIMUM RATINGS ( Ta=25°C )

Parameter	Symbol	Limits	Unit
Supply voltage	V <sub>cc</sub>	13.5	V
Power dissipation	P <sub>d</sub>	1.45 *1	W
Operating temperature	T <sub>opr</sub>	-40 to +85	°C
Storage temperature	T <sub>stg</sub>	-55 to +150	°C

\*1 Reduce power by 11.6 mW for each degree above 25°C, on a glass epoxy PCB (70×70×1.6mm thick).

GUARANTEED OPERATING RANGES

Parameter	Symbol	Limits	Unit
Vcc for pre-block	Pre Vcc	4.5 ~ 13.2	V
Vcc for power-block	Pow Vcc1,2	4.5~Pre Vcc	V

ELECTRICAL CHARACTERISTICS ( Unless otherwise noted,  $T_a=25^{\circ}\text{C}$  , Pre, Pow  $V_{cc}=5\text{V}$  , BIAS=2.5V ,  $R_L=8\Omega$  )

Parameter	Symbol	Test cir -cuit	Conditions	Limits			Unit
				Min.	Typ.	Max.	
Quiescent current	I <sub>cc</sub>	Fig 5	No load , REF1, 2 $\geq 2.0\text{V}$	—	9.0	14.0	mA
Stand-by quiescent current	I <sub>scc</sub>	Fig 5	No load, ref1, 2 $\leq 0.5\text{V}$	—	0	100	$\mu\text{A}$
DRIVER							
Output voltage offset	V <sub>oo</sub>	Fig 5		-50	—	50	mV
Output amplitude 1	V <sub>om1</sub>	Fig 5		3.2	3.5	—	V
Output amplitude 2	V <sub>om2</sub>	Fig 5		3.7	4.0	—	
Gain (close circuit)	G <sub>vc</sub>	Fig 5	BIAS=2.5V, $V_{IN}=\text{BIAS} \pm 0.5\text{V}$	10.0	11.5	13.0	dB
Mute-on voltage	V <sub>mon</sub>	Fig 5		—	—	0.5	V
Mute-off voltage	V <sub>moff</sub>	Fig 5		2.0	—	—	V
Vref-change voltage 1	VREF1	Fig 5		—	—	0.5	V
Vref-change voltage 2	VREF2	Fig 5		2.0	—	—	V
Operational amplifier							
Offset voltage	V <sub>ofop</sub>	Fig 5		-5	0	5	mV
Input bias current	V <sub>bop</sub>	Fig 5		—	—	300	nA
High level output voltage	V <sub>ohop</sub>	Fig 5		4.0	4.36	—	V
Low level output voltage	V <sub>olop</sub>	Fig 5		—	0.74	1.1	V
Output drive current (sink)	I <sub>sink</sub>	Fig 5	50 $\Omega$ , at $V_{cc}$	10	50	—	mA
Output drive current (source)	I <sub>source</sub>	Fig 5	50 $\Omega$ , at ground	10	40	—	mA
Slew rate	S <sub>rop</sub>	Fig 5	100KHz square wave, 2Vpk-pk	—	1	—	V/us

©This product is not designed for protection against radioactive rays.

PACKAGE OUTLINES ( mm )

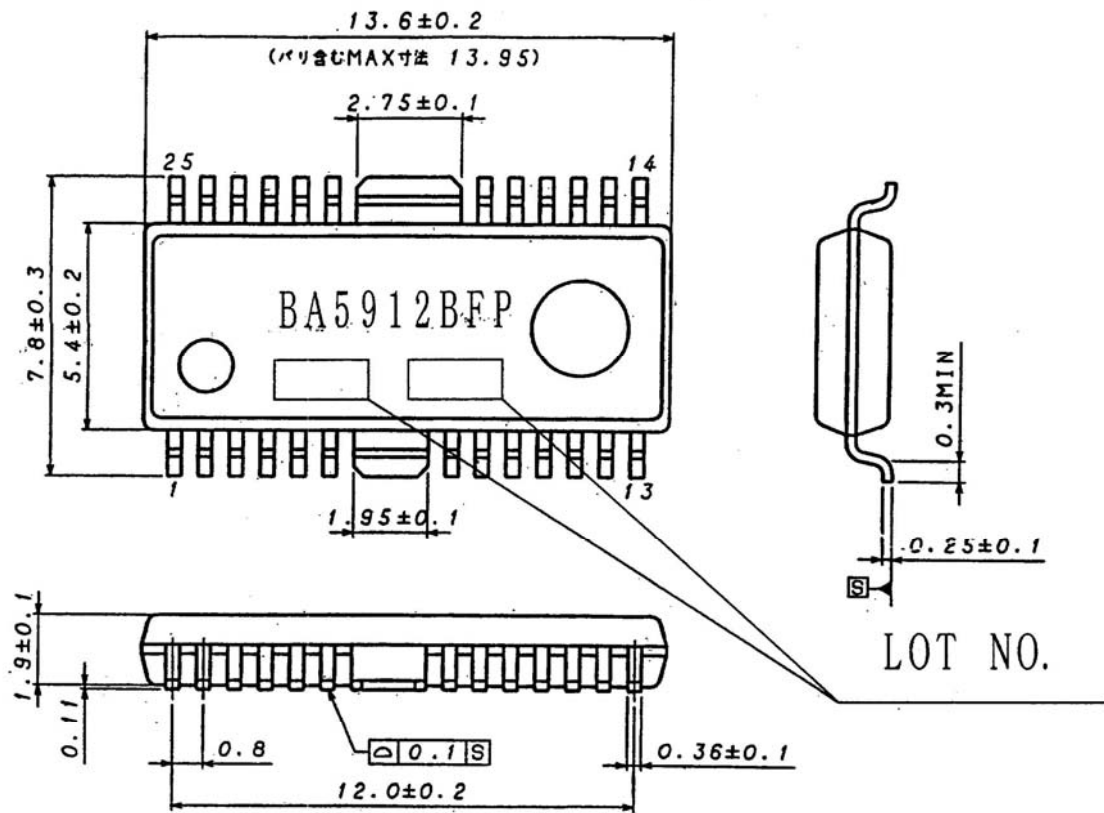

(UNIT : mm)

Figure 1

図番: EX139-5001

POWER DISSIPATION

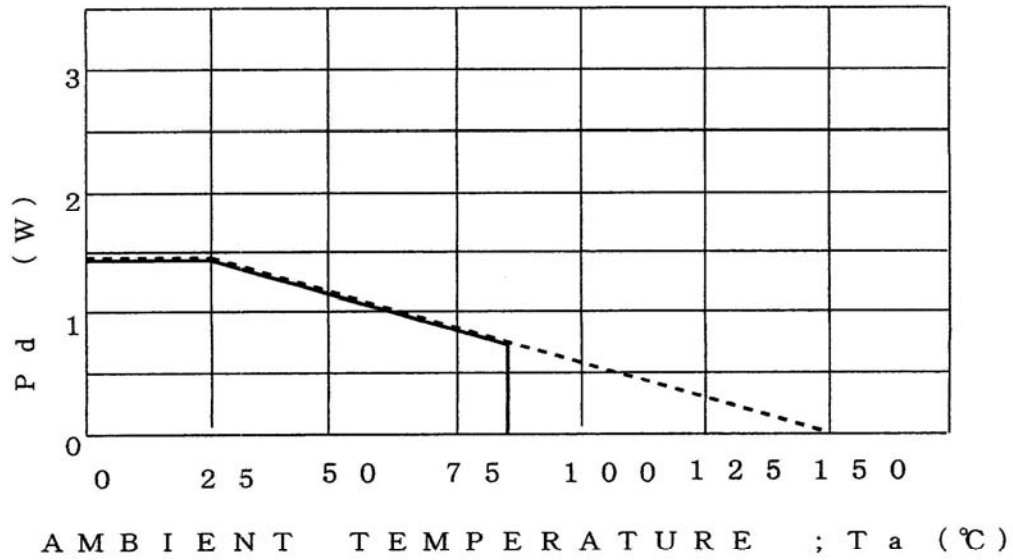

$P_d$  ; power dissipation

Condition : On less than 3% (percentage occupied by copper foil),  $70 \times 70 \text{mm}^2$ ,  
 $T=1.6 \text{mm}$ , glass epoxy mounting

Figure2 Power dissipation curve

BLOCK DIAGRAM

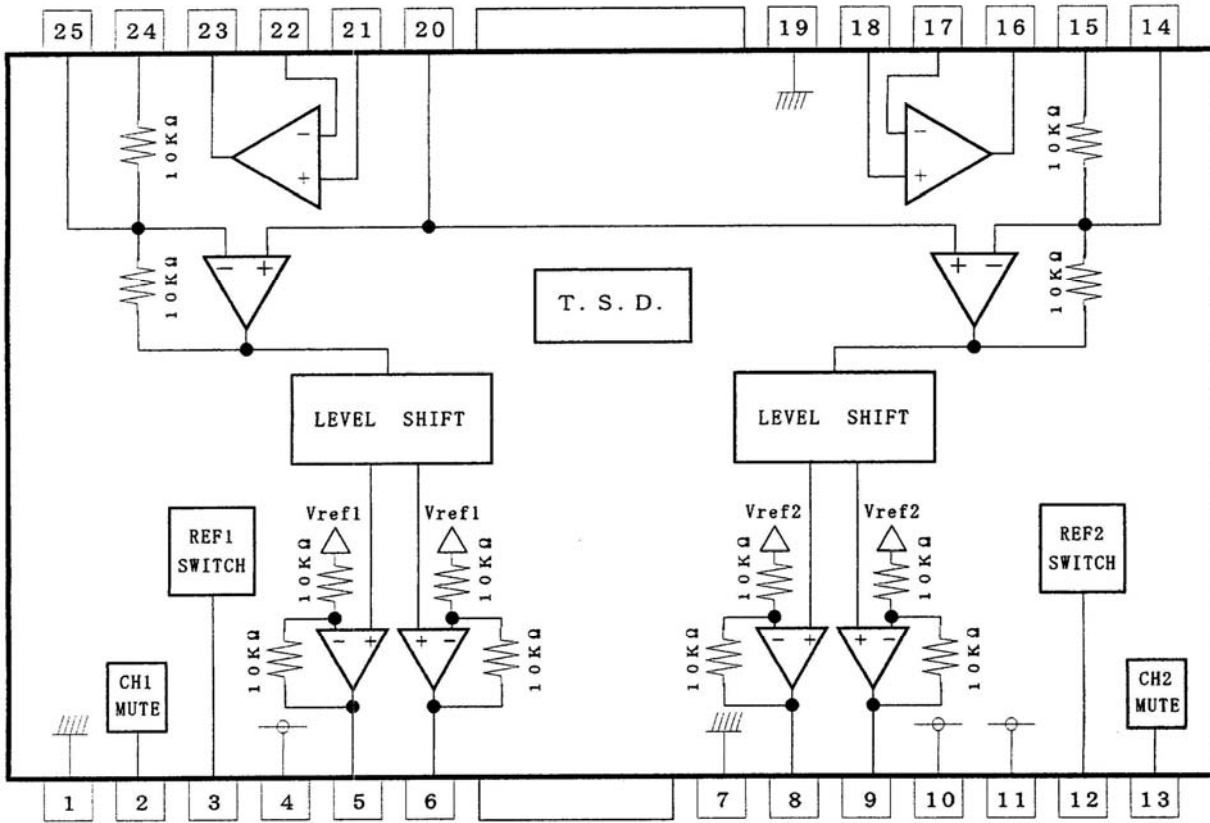

T.S.D. ; Thermal shut down circuit

Limits for resistance value:(Ω)

Figure 3

● PIN DESCRIPTION

NO	SYMBOL	Description	NO	SYMBOL	Description
1	GND	Ground	14	IN2'	Driver CH2 input, gain adjustment pin
2	MUTE1	Mute control pin of CH1	15	IN2	Driver CH2 input
3	REF1	Vref control pin of CH1	16	OP1-OUT	Op-amp1 output
4	Pow Vcc1	Pow Vcc for CH1	17	OP1-IN-	Op-amp1 input, negative
5	OUT1-	Driver CH1 inverted output	18	OP1-IN+	Op-amp1 input, positive
6	OUT1+	Driver CH1 noninverted output	19	GND	Ground
7	GND	Ground	20	BIAS	Bias input
8	OUT2+	Driver CH2 noninverted output	21	OP2-IN+	Op-amp2 input, positive
9	OUT2-	Driver CH2 inverted output	22	OP2-IN-	Op-amp2 input, negative
10	Pow Vcc2	Pow Vcc for CH2	23	OP2-OUT	Op-amp2 output
11	Pre Vcc	Pre Vcc	24	IN1	Driver CH1 input
12	REF2	Vref control pin of CH2	25	INI'	Driver CH1 input, gain adjustment pin
13	MUTE2	Mute control pin of CH2			

●Equivalent circuits of terminals

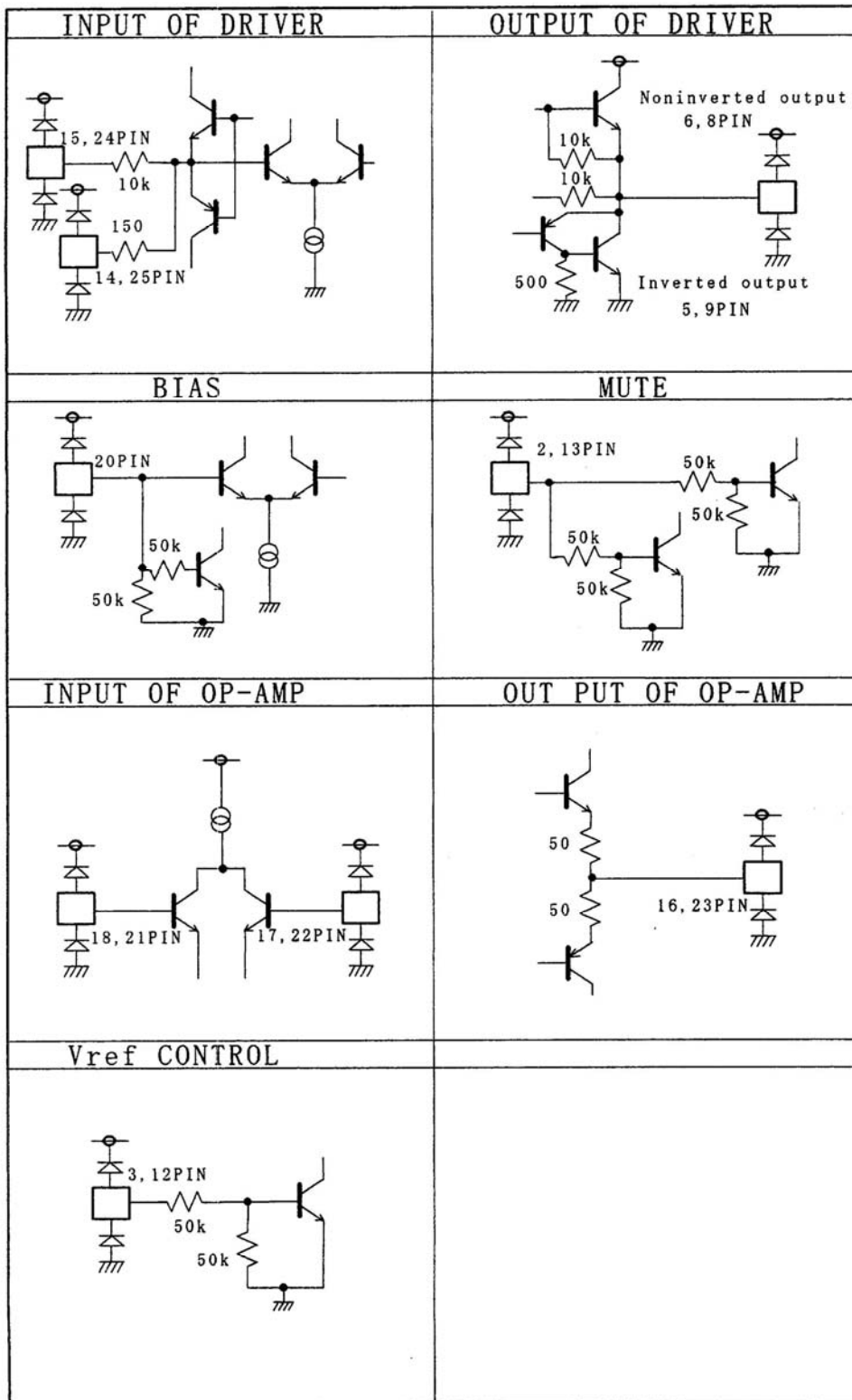

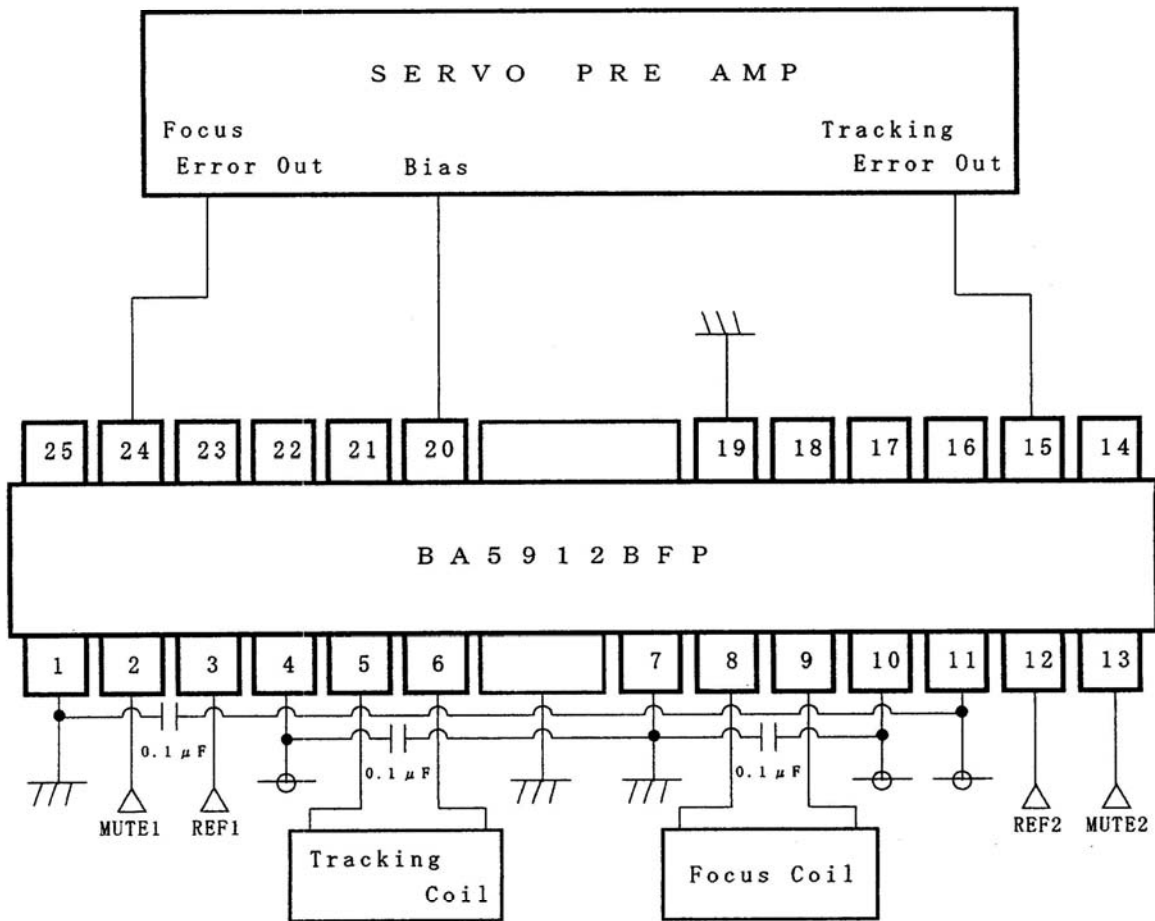

Figure 4



SWITCH TABLE

Table 1

I) DRIVER BLOCK (OPIN→1, NF→1, OPRL→1, VOPIN=2.5V)

Symbol	Switch		Input				Conditions	Measurement point
	Vin1,2	RL1,2	VINDC	VMUTE	VVREF	PREVCC		
Icc	OFF	OFF	-----	2V	2V	5V		ICC
Isc	↓	↓	-----	0V	↓	↓	VMUTE1,2 0V	ICC
Voo	ON	ON	2.5V	2V	↓	↓		V01-4
Vom1	↓	↓	0V, 5V	↓	↓	↓		V01-4
Vom2	↓	↓	0V, 5V	↓	0V	12V		
Gvc	↓	↓	2.2V, 2.8V	↓	2V	5V		V01-4

II) OP-AMP BLOCK (RL→OFF)

Symbol	Switch			Input		Conditions	Measurement point
	OPIN	NF	OPRL	VOPIN	VINSR		
VOFOP	1	1	1	2.5V	-----		VOFOP
IBOP	2	2	1	2.5V	-----		VBOP1-2
VOHOP	1	1	1	5V	-----		VOOP
VOLOP	1	1	1	0V	-----		VOOP
ISINK	1	1	2	2.5V	-----		VOOP
ISOURCE	1	1	3	2.5V	-----		VOOP
SROP	3	1	1	-----		100KHz Square wave, 2Vp-p	VOOP

## © PRECAUTIONS FOR USE

1. A thermal shutdown circuit is built into the BA5912BFP. When the temperature of the chip reaches 175°C (typically), the output current is muted. Next time IC chip temperature falls below 150°C (typ), the driver blocks start.
2. When mute terminal (Pin 2 and 13) voltage is set open or below 0.5V, output current (CH1 and CH2) can be muted independently for each.  
In normal use, increase the pin2 and 13 full above 2.0V. When both mute terminal (pin2 and 13) voltages are set open or below 0.5V, standby mode is automatically established.
3. If the bias pin (pin20) drops below 0.7V, The output is muted. Make sure that under normal operating conditions, this pin is at 1.0V or above.
4. The output is muted in the event of a thermal shut down, mute-on, or a bias and Pre-Vcc voltage drop.  
Only the drivers are muted.  
When muted, the internal bias voltage of the output pin becomes roughly  $(P_{ow} V_{CC} - V_F)/2$  or  $P_{ow} V_{CC}/2$ .
5. Make sure to connect a 0.1  $\mu$ F capacitor to the dc supplied power main input to filter out voltage ripples.
6. Heat dissipation fins are attached to the GND on the inside of the package. Make sure to connect these to the external GND.
7. If Pre Vcc drops below 3.5V (typ), the drivers are turned off. When the voltage exceeds 4.0V (typ), the drivers return to their previous state.
8. When Pre Vcc = Pow Vcc, set Vref switching terminal open or below 0.5V (internal bias voltage =  $(P_{ow} V_{CC} - V_F)/2$ ), and when Pre Vcc > Pow Vcc + VF, increase the Vref switching terminal full above 2.0V (internal bias voltage =  $P_{ow} V_{CC}/2$ ).

## Notes

No copying or reproduction of this document, in part or in whole, is permitted without the consent of ROHM Co.,Ltd.

The content specified herein is subject to change for improvement without notice.

The content specified herein is for the purpose of introducing ROHM's products (hereinafter "Products"). If you wish to use any such Product, please be sure to refer to the specifications, which can be obtained from ROHM upon request.

Examples of application circuits, circuit constants and any other information contained herein illustrate the standard usage and operations of the Products. The peripheral conditions must be taken into account when designing circuits for mass production.

Great care was taken in ensuring the accuracy of the information specified in this document. However, should you incur any damage arising from any inaccuracy or misprint of such information, ROHM shall bear no responsibility for such damage.

The technical information specified herein is intended only to show the typical functions of and examples of application circuits for the Products. ROHM does not grant you, explicitly or implicitly, any license to use or exercise intellectual property or other rights held by ROHM and other parties. ROHM shall bear no responsibility whatsoever for any dispute arising from the use of such technical information.

The Products specified in this document are intended to be used with general-use electronic equipment or devices (such as audio visual equipment, office-automation equipment, communication devices, electronic appliances and amusement devices).

The Products specified in this document are not designed to be radiation tolerant.

While ROHM always makes efforts to enhance the quality and reliability of its Products, a Product may fail or malfunction for a variety of reasons.

Please be sure to implement in your equipment using the Products safety measures to guard against the possibility of physical injury, fire or any other damage caused in the event of the failure of any Product, such as derating, redundancy, fire control and fail-safe designs. ROHM shall bear no responsibility whatsoever for your use of any Product outside of the prescribed scope or not in accordance with the instruction manual.

The Products are not designed or manufactured to be used with any equipment, device or system which requires an extremely high level of reliability the failure or malfunction of which may result in a direct threat to human life or create a risk of human injury (such as a medical instrument, transportation equipment, aerospace machinery, nuclear-reactor controller, fuel-controller or other safety device). ROHM shall bear no responsibility in any way for use of any of the Products for the above special purposes. If a Product is intended to be used for any such special purpose, please contact a ROHM sales representative before purchasing.

If you intend to export or ship overseas any Product or technology specified herein that may be controlled under the Foreign Exchange and the Foreign Trade Law, you will be required to obtain a license or permit under the Law.





Thank you for your accessing to ROHM product informations.  
More detail product informations and catalogs are available, please contact us.

### ROHM Customer Support System

<http://www.rohm.com/contact/>

## Looking for pricing, stock, or lifecycle information?

Click below to explore more details on WIN SOURCE:

-  [View BA5912BFP-E2 on WIN SOURCE](#)
-  [Rohm Semiconductor](#) Information

## Optimize Your Supply Chain with WIN SOURCE Solutions

-  Global Sourcing Solution
-  Obsolete Management
-  Cost Control Management
-  Shortage Management
-  Alternative Solution
-  Excess Inventory Management