



**THE DATASHEET OF
GMK316AB7106KL-TR**



PRODUCT SPECIFICATION

P/N: GMK316AB7106KL-TR

Type: High Value Multilayer Ceramic Capacitors

Issue date: February 28.2013

Applicable products to RoHS restriction

TAIYO YUDEN CO., LTD.

Document No.

MLCEE13058

Specifications
High Value Multilayer Ceramic Capacitor
(High dielectric type)

1. Scope

This specification covers multilayer chip type ceramic capacitor (Pb-Free) for use(for reflow soldering) in electronic appliances and electric communication equipment.

2. Part Numbering System

Part number is indicated as follows:

(Example) : $\frac{\text{G}}{\text{①}}$ MK $\frac{316}{\text{②}}$ $\frac{\text{A}}{\text{③}}$ $\frac{\text{B7}}{\text{④}}$ $\frac{106}{\text{Capacitance } \text{⑤}}$ $\frac{\text{K}}{\text{⑥}}$ $\frac{\text{L}}{\text{⑦}}$ $\frac{-\text{TR}}{\text{⑦}}$

① Rated voltage

Code	Voltage [VDC]
G	35

② Size

Code	Size [mm]
316	3.2×1.6

③ Control Code: Per Table 1

④ Temperature Characteristic

Characteristic	Capacitance change rate [%]	Temperature range [°C]	Reference temperature [°C]
B7 (X7R)	±15 (EIA)	-55 to +125	25

⑤ Tolerance

Code	Tolerance [%]
K	±10
M	±20

⑥ Thickness code

Type	Code	Thickness [mm]
316	L	1.60

⑦ Packaging

Code	Packaging type
-TR	Taping

High Value Multilayer Ceramic Chip Capacitor

3. Test Conditions

Standard test conditions shall be temperature of 5 to 35°C, relative humidity of 45 to 85% and air pressure of 86 to 106kPa. Tests shall be conducted at temperature of 25±3°C, relative humidity of 60 to 70% and air pressure of 86 to 106kPa if test results are suspicious.

Unless otherwise specified, all tests shall be conducted under the standard test conditions.

4. Construction, Dimensions and Performance

Details of construction, dimensions and performance shall be specified in the following pages.

5. Packaging

Capacitors shall be packaged properly to avoid damage in the capacitors during transportation and storage.

The package shall be marked with part number, quantity, lot number, and manufacturer's name at its appropriate position.

6. Manufacturing site

TAIYO YUDEN CO., LTD. (JAPAN)

TAIYO YUDEN (SARAWAK) SDN, BHD. (MALAYSIA)

KOREA KYONG NAM TAIYO YUDEN CO., LTD. (KOREA)

TAIYO YUDEN (GUANG DONG) CO., LTD. (CHINA)

TAIYO YUDEN (PHILIPPINES) INC. (PHILIPPINES)

7. Precautions

- This specification does not cover capacitors when Sn-Zn lead free solder is used.
- If you need further information, please contact us.

8. Storage conditions

- Temperature and humidity in storage area shall be controlled carefully to maintain the solderability of terminal electrodes and to keep the packaging material in good condition. Humidity should especially be kept as low as possible.

- Recommended conditions

Ambient temperature: 30°C or below

Humidity: 70% RH or below

The ambient temperature must be kept below +40°C. Even under ideal storage conditions, capacitor electrode solderability decreases with time. Therefore ceramic chip capacitors should be used within 6 months from the time of delivery. If the period is exceeded, please check solderability before using the capacitors.

- The packaging material should be kept where no chlorine or sulfur exists in the air.

High Value Multilayer Ceramic Chip Capacitor

9. RoHS compliance

- Our products conform to RoHS.
- "RoHS compliance" means that the product does not contain lead, cadmium, mercury, hexavalent chromium, PBB or PBDE referring to EU Directive 2002/95/EC, except other non-restricted substances or impurities which cannot be technically removed at refining process.
- Our products are halogen-free products.

10. Others

Resin-coating:

- Coating/molding capacitors with resin may have negative effects on the capacitor functions.
- When capacitors are coated/molded with resin, please check effects on the capacitors by analyzing them in actual applications prior to use.

No.	Item	Specified Value	Remarks				
1	Operating Temperature Range	Capable of continuous operation under these conditions.	-55 to +125°C				
2	Shape and Dimensions	Per Fig.1 and Table 1					
3	Heat Treatment		Initial value shall be measured after test sample is heat-treated at 150 +0/-10°C for an hour and kept at room temperature for 24±2hours.				
4	Voltage Treatment		Initial value shall be measured after test sample is voltage-treated for an hour at temperature and voltage which are specified as test conditions, and kept at room temperature for 24±2hours.				
5	Dielectric Withstanding Voltage (between terminals)	No abnormality	Conforming to EIA RS-198 (1991). 250% of DC rated voltage shall be applied for 1 to 5 seconds. Charging and discharging current shall be 50mA or less.				
6	Insulation Resistance (IR)	100MΩ · μF min.	Conforming to EIA RS-198 (1991). Rated voltage shall be applied to test sample for 1 minute±5 seconds. Charging and discharging current shall be 50mA or less.				
7	Capacitance (Cap.)	10.0 μF	Conforming to EIA RS-198 (1991). Heat treatment specified in this specification shall be conducted prior to measurement. Measuring frequency and voltage shall conform to the table below. <table border="1" data-bbox="847 1167 1465 1234"> <thead> <tr> <th>Measuring Frequency</th> <th>Measuring Voltage</th> </tr> </thead> <tbody> <tr> <td>1kHz ± 10%</td> <td>1.0 ± 0.2Vrms</td> </tr> </tbody> </table>	Measuring Frequency	Measuring Voltage	1kHz ± 10%	1.0 ± 0.2Vrms
Measuring Frequency	Measuring Voltage						
1kHz ± 10%	1.0 ± 0.2Vrms						
8	Dissipation Factor (DF)	10.0%max	Conforming to EIA RS-198 (1991). Heat treatment specified in this specification shall be conducted prior to measurement. Measuring frequency and voltage shall conform to the table below. <table border="1" data-bbox="847 1543 1465 1610"> <thead> <tr> <th>Measuring Frequency</th> <th>Measuring Voltage</th> </tr> </thead> <tbody> <tr> <td>1kHz ± 10%</td> <td>1.0 ± 0.2Vrms</td> </tr> </tbody> </table>	Measuring Frequency	Measuring Voltage	1kHz ± 10%	1.0 ± 0.2Vrms
Measuring Frequency	Measuring Voltage						
1kHz ± 10%	1.0 ± 0.2Vrms						

No.	Item	Specified Value	Remarks
9	Temperature Characteristic	Per P.1 for ④Temperature Characteristic	Conforming to EIA RS-198 (1991). Heat treatment specified in this specification shall be conducted prior to measurement. Maximum capacitance deviation in both (+) and (-) sides in range of lowest temperature to highest temperature for capacitor shall be indicated in ratio of variation in reference to capacitance value at reference temperature.
10	Adhesive Force of Terminal Electrodes	Terminal electrodes shall be no exfoliation or a sign of exfoliation.	Test sample shall be soldered to test board shown in Fig.2 and a force of 5N{0.51kgf} shall be applied in vertically downward direction for 30±5 seconds.
11	Vibration	Initial performance shall be satisfied.	Conforming to EIA RS-198 (1991). Test sample shall be soldered to board shown in Fig.2. Heat treatment specified in this specification shall be conducted prior to test. Test conditions: Frequency range: 10-55Hz Overall amplitude: 1.5mm Sweeping method: 10-55-10Hz for 1 min. Each two hours in X,Y,Z direction: 6 hours in total

No.	Item	Specified Value	Remarks															
12	Solderability	More than 95% of terminal electrode shall be covered with fresh solder.	<p>【Eutectic】 Solder used shall be [JIS Z 3282 H60A or H63A]. Test sample shall be completely submerged in molten solder at 230±5°C for 4±1 seconds.</p>															
			<p>【Pb free】 Solder used shall be [Sn/3.0Ag/0.5Cu]. Test sample shall be completely submerged in molten solder at 245±3°C for 4±1 seconds.</p>															
13	Resistance to Soldering Heat	Appearance	No abnormality															
		Cap. Change	±7.5%															
		DF	10.0%max															
		IR	Initial value shall be satisfied.															
		Dielectric Withstanding Voltage (between terminals)	No dielectric breakdown or damage															
			<p>Conforming to EIA RS-198 (1991). Solder used shall be [JIS Z 3282 H60A or H63A]. Test sample shall be completely submerged in molten solder of 270±5°C for 3±0.5 seconds. Preheating as shown in the table below shall be continuously conducted before submersion and test sample shall be kept at ambient temperature after test.</p> <table border="1"> <thead> <tr> <th>Sequence</th> <th>Temperature (°C)</th> <th>Time (min)</th> </tr> </thead> <tbody> <tr> <td>1</td> <td>80 to 100</td> <td>5 to 10</td> </tr> <tr> <td>2</td> <td>150 to 200</td> <td>5 to 10</td> </tr> </tbody> </table> <p>Heat treatment specified in this specification shall be conducted prior to test. Measurement shall be conducted after test sample is kept at ambient temperature for 24±2 hours.</p>	Sequence	Temperature (°C)	Time (min)	1	80 to 100	5 to 10	2	150 to 200	5 to 10						
Sequence	Temperature (°C)	Time (min)																
1	80 to 100	5 to 10																
2	150 to 200	5 to 10																
14	Thermal Shock	Appearance	No abnormality															
		Cap. Change	±7.5%															
		DF	10.0%max															
		IR	Initial value shall be satisfied.															
		Dielectric Withstanding Voltage (between terminals)	No dielectric breakdown or damage															
			<p>Conforming to EIA RS-198 (1991). Test sample shall be soldered to board shown in Fig.2. Heat treatment specified in this specification shall be conducted prior to test. Test sample shall be exposed to each of temperature conditions in the following Steps 1 to 4 in sequence for the specified time.</p> <table border="1"> <thead> <tr> <th>Step</th> <th>Temperature (°C)</th> <th>Time (min)</th> </tr> </thead> <tbody> <tr> <td>1</td> <td>Lowest operating temperature</td> <td>30±3</td> </tr> <tr> <td>2</td> <td>Ambient temperature</td> <td>2 to 3</td> </tr> <tr> <td>3</td> <td>Highest operating temperature</td> <td>30±3</td> </tr> <tr> <td>4</td> <td>Ambient temperature</td> <td>2 to 3</td> </tr> </tbody> </table> <p>Temperature cycle shall be repeated five times in this method, and measurement shall be conducted after test sample is kept at ambient temperature for 24±2 hours.</p>	Step	Temperature (°C)	Time (min)	1	Lowest operating temperature	30±3	2	Ambient temperature	2 to 3	3	Highest operating temperature	30±3	4	Ambient temperature	2 to 3
Step	Temperature (°C)	Time (min)																
1	Lowest operating temperature	30±3																
2	Ambient temperature	2 to 3																
3	Highest operating temperature	30±3																
4	Ambient temperature	2 to 3																

No.	Item	Specified Value	Remarks	
15	Humidity (Steady State)	Appearance	No abnormality	<p>Conforming to EIA RS-198 (1991). Heat treatment specified in this specification shall be conducted prior to test. Test sample shall be put into constant temperature/humidity bath at 40±2 °C and 90 to 95%RH for 500 +24/-0 hours. Measurement shall be conducted after test sample is kept for 24±2 hours.</p>
		Cap. Change	±12.5%	
		DF	15.0%max	
		IR	50MΩ · μF min.	
16	High Temperature Loading	Appearance	No abnormality	<p>Conforming to EIA RS-198 (1991). Voltage treatment specified in this specification shall be conducted prior to test. Test sample shall be put in thermostatic oven at maximum operating temperature and 150% of DC voltage shall be continuously applied for 1000 +48/-0 hours. Charging and discharging current shall be 50mA or less. Measurement shall be conducted after test sample is kept at ambient temperature for 24±2 hours.</p>
		Cap. Change	±20.0%	
		DF	15.0%max	
		IR	50MΩ · μF min.	
17	Humidity Loading	Appearance	No abnormality	<p>Conforming to EIA RS-198 (1991). Voltage treatment specified in the specification shall be conducted prior to test. Test sample shall be put into constant temperature/humidity bath at 40±2 °C and 90 to 95%RH, and DC rated voltage shall be continuously applied for 500 +24/-0 hours. Charging and discharging current shall be 50mA or less. Measurement shall be conducted after test sample is kept at ambient temperature for 24±2 hours.</p>
		Cap. Change	±20.0%	
		DF	15.0%max	
		IR	25MΩ · μF min.	
18	Bending Strength	Appearance	No abnormality	<p>Test sample shall be soldered to test board as shown in Fig.3. Sample shall be carefully soldered to avoid abnormality such as heat shock. The board is bent 1.0mm for 10 seconds as shown in Fig.4. Measurement shall be conducted as the board is bent 1.0mm.</p>
		Cap. Change	±12.5%	

Fig.1: Shape

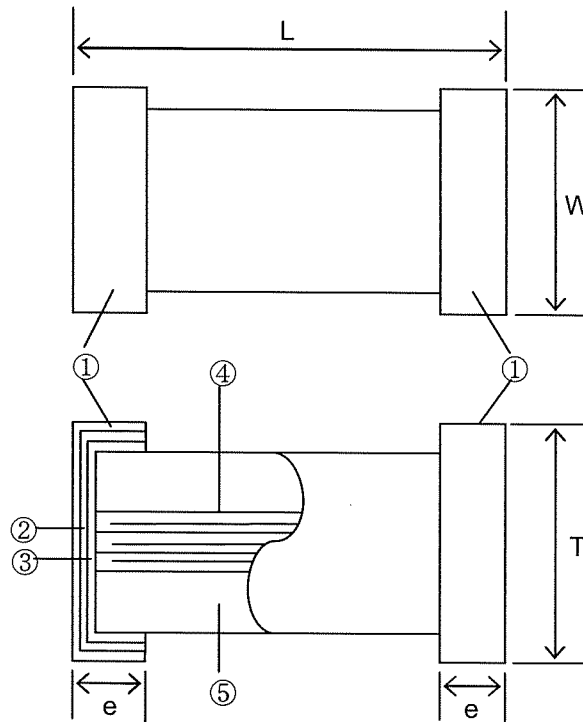

No.	Name	Material
①	Terminal Electrodes (Surface)	Sn Plating
②	Terminal Electrodes	Ni Plating
		Cu Plating
③	External Electrodes	Ni
④	Internal Electrodes	Ni
⑤	Dielectric	Barium titanate

Table 1: Dimensions

Item type	Control code	Dimension [Unit: mm]			
		L	W	T	e
316	A	3.2 ± 0.2	1.6 ± 0.2	1.6 ± 0.2	$0.5 + 0.35 / - 0.25$

Fig.2: Board / Test Jig of Adhesive Force of Terminal Electrodes, Vibration, and Thermal Shock

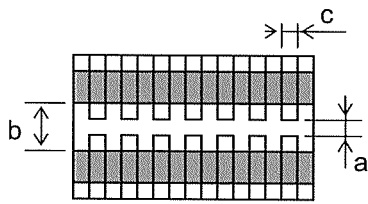

Size (L×W)	a	b	c
3.2×1.6	2.2	5.0	2.0

[Unit: mm]

Material: Glass epoxy board [JIS C 6484]

- Copper foil (Thickness: 0.035mm)
- Solder resist

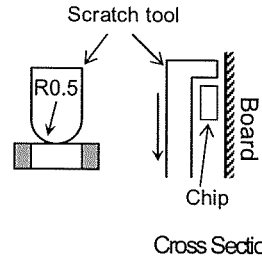

Remarks: Uniform soldering shall be conducted with solder (H60A or H63A in JIS Z 3282) by using soldering iron or soldering oven.
Soldering shall be conducted with care to avoid abnormality such as heat shock.

Fig.3: Test Board

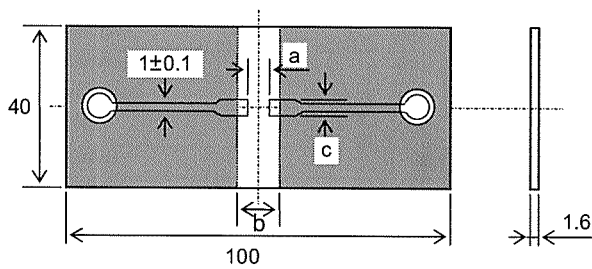

Material: Glass epoxy board [JIS C 6484]

- Copper foil (Thickness: 0.035mm)
- Solder resist

Size (L×W)	a	b	c
3.2×1.6	2.2	5.0	2.0

[Unit: mm]

Fig.4:

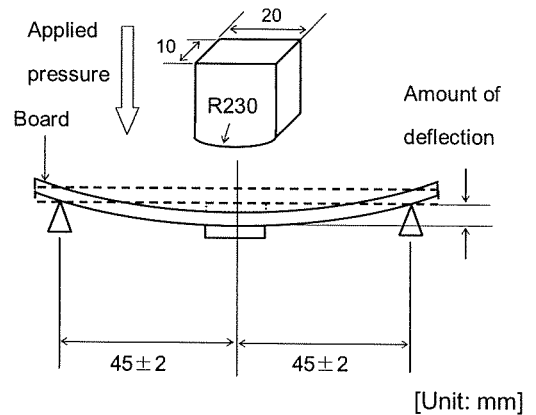

Apply pressure at the rate of 0.5mm/sec. until amount of deflection reaches 1.0mm.

Tape Packaging 107 · 212 · 316 · 325 Type

◎ Tape packaging type:

- Paper tape: 107-case-type products and products with 0.85mm-thickness;
- Embossed tape: Products with 1.15mm-thickness or over and 325-case-type products with 0.85mm-thickness.

Dimensions [Unit: mm] ※1

Type	A	B
107	1.0±0.2	1.8±0.2
	1.1±0.2 ※2	1.9±0.2 ※2
212	1.65±0.2	2.4±0.2

Type	A	B
316	2.0±0.2	3.6±0.2
	2.1±0.2 ※3	3.7±0.2 ※3
325	2.8±0.2	3.6±0.2
	3.1±0.2 ※4	4.0±0.2 ※4

Dimensions [Unit: mm]

Type	C	D	E	F	G	H	J	K※1	t※1
107 to 325	8.0±0.3	3.5±0.05	1.75±0.1	4.0±0.1	2.0±0.05	4.0±0.1	φ 1.5 +0.1/-0	- (Paper tape)	1.1 max. (Paper tape)
325※4	12.0±0.3	5.5±0.05						3.4 max. 3.7 max.	1.2 max. (Paper tape) ※2
									0.6 max.

※1: A, B, K, t: Sufficient clearances are secured.

※2: *MK107B*****T

※3: *MK316B*****T

※4: AMK325ABJ227MM-T

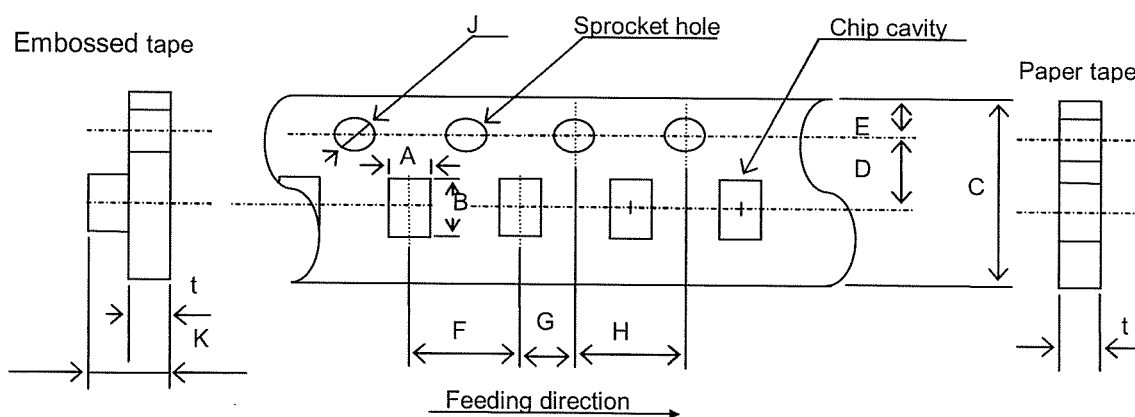

Tape Packaging 107 · 212 · 316 · 325 Type

Dimensions of Reel [Unit: mm]

Type	A	B	C	D	E	W	t	R
107 to 325	$\phi 178 \pm 2.0$	$\phi 50 \text{ min.}$	$\phi 13.0 \pm 0.2$	$\phi 21.0 \pm 0.8$	2.0 ± 0.5	10.0 ± 1.5	2.5max.	1.0
325※	$\phi 178 \pm 2.0$	$\phi 50 \text{ min.}$	$\phi 13.0 \pm 0.2$	$\phi 21.0 \pm 0.8$	2.0 ± 0.5	14.0 ± 1.5	2.5max.	1.0

※ : AMK325ABJ227MM-T

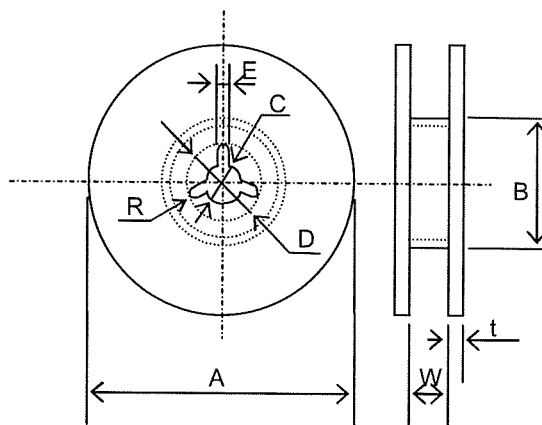

Tape Packaging 107, 212, 316, 325 TYPE

1. Taping shall be right-sided wound. Sprocket hole shall be on the right side against the pull-out direction.
2. Either the width side (W) or the thickness side (t) of the components below faces up at random when the components are inserted in the chip cavities.

107(0603) type with 0.8mm-thickness, 212(0805) type with 1.25mm-thickness,
 316(1206) type with 1.6mm-thickness, 325(1210) type with 2.5mm-thickness

3. There shall be blank spaces in each reel tape as shown in the following figure.

- Leader part 400mm min.
- Leader part (Blank part) 100mm min.
- Trailer (Blank part) 160mm min.

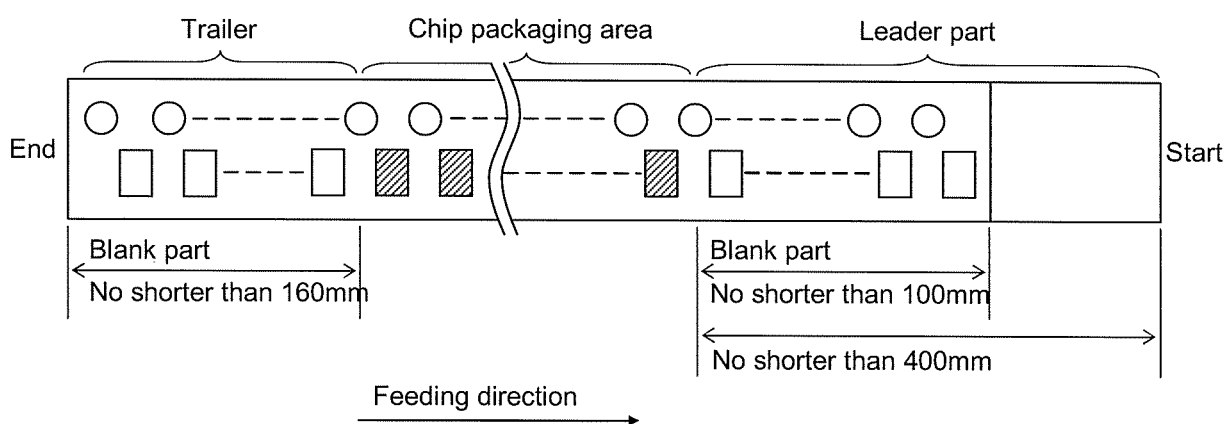

4. Neither top/bottom tapes of paper tape nor top tape of embossed tape shall cover sprocket holes.
5. There shall no seam on paper tape and embossed tape.
6. Tensile strength of the tape shall be 5N (0.51kgf) or over.
7. The number of the chip missing from tape reel shall be 1 piece at a maximum per reel.
8. The number of packaged chips per reel is shown in the table below.
9. Label indicating part No., quantity and control No. shall be attached to the outside of reel.
10. Peeling strength of top tape shall be 0.1 to 0.7N (10.2 to 71.4gf) when top tape is peeled from carrier tape at an angle of 0 to 20 degrees.

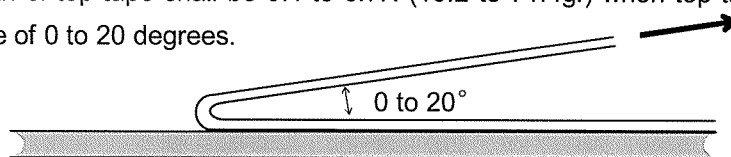

Quantity of taping package

Type	Thickness [Unit: mm] (Thickness code)	Quantity (pcs/reel)	Carrier tape
107	0.45(K)	4,000	Paper
	0.80(A)		
212	0.45(K)	3,000	Embossed (Plastic)
	0.85(D)		
316	1.25(G)	4,000	Paper
	1.15(F)	3,000	Embossed (Plastic)
	1.60(L)	2,000	

Type	Thickness [Unit: mm] (Thickness code)	Quantity (pcs/reel)	Carrier tape
325	0.85(D)	2,000	Embossed (Plastic)
	1.15(F)		
	1.50(H)		
	1.90(N)		
	1.9+0.1/-0.2(Y)		
	2.50(M)※	500 or 1000	

※For 325 type with 2.50(M)-thickness products, Packaging code "-T" means 500 pcs per reel and "-P" means 1000 pcs per reel.

Tape Packaging 107, 212, 316, 325 TYPE

[Packaging Mode]

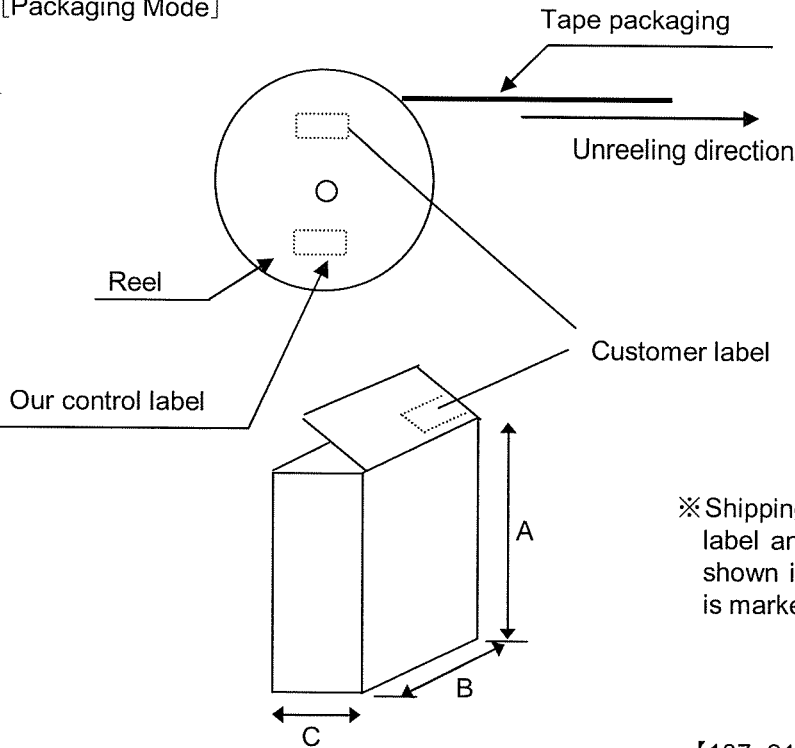

Customer Label contents

1. Manufacturer Name
2. Customer Parts No.
3. Our parts no.
4. Quantity
5. Control No.
(Shipping lot number) ※
6. Manufacturing site
MADE IN ○○○

※ Shipping lot number is marked on our control label and is also traceable from Control number shown in customer label; no shipping lot number is marked on customer label.

[107, 212, 316, 325]

Code	A	B	C	Reel
Size	190	185	70	5 reels max.
			140	10 reels max.

Material: Paper

[Unit: mm]

(The size is only for reference.)

Packaging unit: 5 reels or 10 reels in a box at a maximum.

[AMK325ABJ227MM-T]

Code	A	B	C	Reel
Size	190	185	70	4 reels max.
			140	8 reels max.

Material: Paper

[Unit: mm]

(The size is only for reference.)

Packaging unit: 4 reels or 8 reels in a box at a maximum

Note:

Labels are attached on reels/boxes only after components passed all inspections.

Labeled products: Acceptance components

Shipping Lot No.

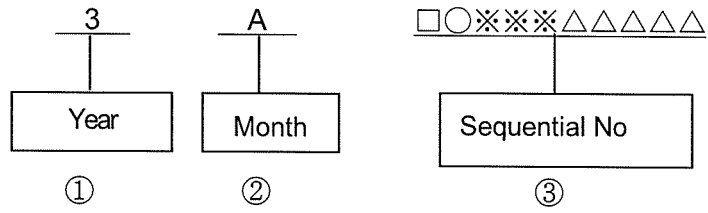

- ① First digit of lot No.: Production year (Last number of the Christian era)
Example: 2013year → 3
- ② Second digit of lot No.: Month of production (See the table below.)
- ③ Sequence number of lot No.: Alphanumeric characters including space

Month	1	2	3	4	5	6	7	8	9	10	11	12
Code	A	B	C	D	E	F	G	H	J	K	L	M

Recommended Soldering Profiles for Lead-free Solder Paste

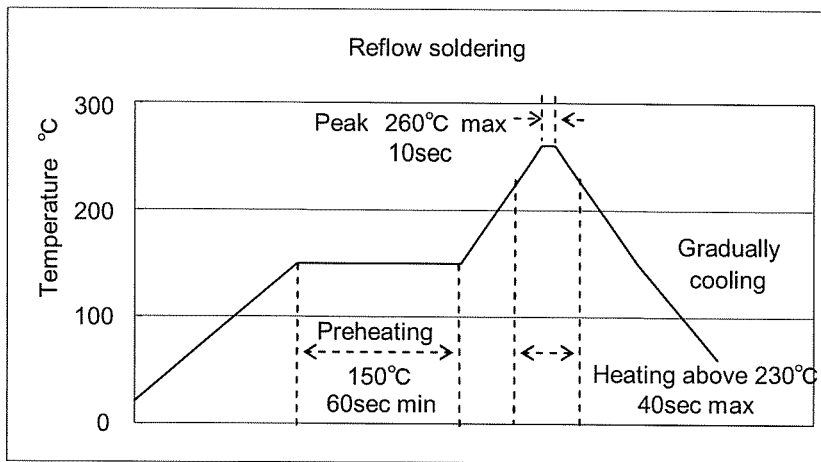

- ※Ceramic chip components should be preheated to within **100 to 130°C** from the soldering temperature.
- ※Assured to be reflow soldering for **2 times**.

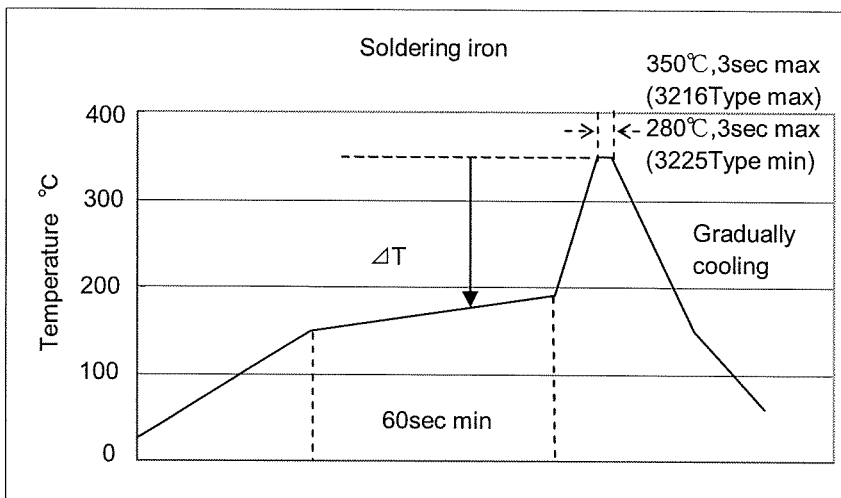

- ※ $\Delta T \leq 150^\circ\text{C}$ (3216Type max) , $\Delta T \leq 130^\circ\text{C}$ (3225Type min)
- ※Preheating control: Boards and components should be preheated sufficiently with temperature over 150°C, and soldering should be conducted by soldering iron while temperature of boards and components keep sufficient temperature.
- ※The soldering iron should not directly touch the components.
- ※Assured to be soldering iron for **1 time**.
- ※It is recommended to use 20W soldering iron and the tip is 1 ϕ or less.

Temperature in usage of Pb-free solder (Sn-3Ag-0.5Cu)

Case size	Soldering iron tip temp.	Preheating temp.
3216 type max.	$\leq 350^\circ\text{C}$	$\geq 150^\circ\text{C}$
3225 type min.	$\leq 280^\circ\text{C}$	$\geq 150^\circ\text{C}$

Note: The above profiles are the maximum allowable soldering condition, therefore these profiles are not always recommended.

Operating conditions for guarantee of products are as shown in the specification.

Please note that TAIYO YUDEN CO., LTD. shall not be responsible for a failure and/or abnormality which are caused by use under the conditions other than aforesaid operating conditions.

■ All electronic components listed in this specification are developed, designed and intended for use in general electronics equipment.(for AV, office automation, household, office supply, information service, telecommunications, (such as mobile phone or PC) etc.). Before incorporating the components or devices into any equipment in the field such as transportation, (automotive control, train control, ship control), transportation signal, disaster prevention, medical, public information network(telephone exchange, base station) etc. which may have direct influence to harm or injure a human body, please contact TAIYO YUDEN CO., LTD. for more detail in advance.

Do not incorporate the components into any equipment in fields such as aerospace, aviation, nuclear control, submarine system, military, etc. where higher safety and reliability are especially required. In addition, even electronic components or functional modules that are used for the general electronic equipment, if the equipment or the electric circuit require high safety or reliability function or performances, a sufficient reliability evaluation check for safety shall be performed before commercial shipment and moreover, due consideration to install a protective circuit is strongly recommended at customer's design stage.

■ Please conduct validation and verification of products in actual condition of mounting and operating environment before commercial shipment of the equipment.

■ The contents of this specification are applicable to the components which are purchased from our sales offices or distributors (so called TAIYO YUDEN's official sales channel).

It is only applicable to the components purchased from any of TAIYO YUDEN's official sales channel.

■ Please note that TAIYO YUDEN CO., LTD. shall have no responsibility for any controversies or disputes that may occur in connection with a third party's intellectual property rights and other related rights arising from your usage of products in this specification. Taiyo Yuden Co., Ltd. grants no license for such rights.

■ Caution for export

Certain items in this specification may require specific procedures for export according to Foreign Exchange and Foreign Trade Control Law of Japan, U.S. Export Administration Regulations, and other applicable regulations. Should you have any question or inquiry on this matter, please contact our sales staff.

Looking for pricing, stock, or lifecycle information?

Click below to explore more details on WIN SOURCE:

- ⊖ [View GMK316AB7106KL-TR on WIN SOURCE](#)
- ⊖ [Taiyo Yuden Information](#)

Optimize Your Supply Chain with WIN SOURCE Solutions

- ✓ Global Sourcing Solution
- ✓ Obsolete Management
- ✓ Cost Control Management
- ✓ Shortage Management
- ✓ Alternative Solution
- ✓ Excess Inventory Management