

- STRUCTURE : Silicon Monolithic Integrated Circuit
 PRODUCT SERIES : Power driver for compact disc player
 TYPE : BA5830FM
- Features
- 4CH BTL Driver.
 - Employs the HSOP-M28PIN power package for compaction.
 - Has a wide dynamic range. (PreVcc=PowVcc=8V,RL=8Ω、 6.0V(typ.))
 - Incorporates the thermal shutdown circuit.
 - Separating Vcc into Pre and Power (Power divides into CH1/2 and CH3/4), can make better Power efficiency.
 - Switches CH4 input by CNT.
 - Incorporates mute function by CNT terminal and mute terminal.
 - A variable regulator is built in.

Absolute Maximum Rating (Ta=25)

Item	Symbol	Rating	Unit
Supply voltage	PreVcc,PowVcc	18	V
Input terminal voltage	VIN ^{*1}	18	V
Power dissipation	Pd	2.2 ^{*2}	W
Maximum output current	Iomax	1 ^{*3}	A
Operating temperature range	Topr	-40 ~ +85	
Storage temperature range	Tstg	-55 ~ +150	

*1 It shows each terminal of OPIN1(-),OPIN2(-),OPIN3(-),OPINSL(-),OPOUT1,OPOUT2,OPOUT3, OPOUTSL,LDIN,BIAS,CNT,MUTE,REG(+)

*2 Rating for 70mm×70mm(size), 1.6mm(thickness), copper foil occupation ratio less than 3%, And use of glass-epoxy substrate.
 When this IC is used above Ta=25 , note that this rating decreases 17.6mW each time the temperature increases 1 .

*3 This rating of permissible dissipation must not exceed ASO.

Operating Supply Range (To determine a power supply voltage, the power dissipation must be taken into consideration.)

PreVcc	5.5 ~ 14 (V)*4
PowVcc	4.5 ~ PreVcc (V)

*4 When regulator isn't used, 4.5 ~ 14(V)

Status of this document

The Japanese version of this document is the formal specification.
 A customer may use this translation version only for a reference to help reading the formal version.
 If there are any differences in translation version of this document , formal version takes priority.

Be careful to handle because the content of the description of this material might correspond to the labor (technology in the design, manufacturing,and use) in foreign country exchange and Foreign Trade Control Law.

A radiation is not designed.

Electrical characteristics (Unless otherwise noted, Ta=25 , PreVcc=PowVcc=8V, BIAS=2.5V, RL=8Ω)

Parameter	Symbol	MIN	TYP	MAX	Unit	Condition
Quiescent dissipation current	IQ	-	22	32	mA	RL=∞
<Driver>						
Output offset voltage	V _{oof}	-50	0	50	mV	
Maximum output amplitude	V _{OM}	5.4	6.0	-	V	
Closed circuit voltage gain (CH1,2,3,SLED)	G _{vc}	10.0	11.7	13.4	dB	V _{IN} = ± 0.5V
Closed circuit voltage gain (LOADING)	G _{vcLD}	16.0	17.7	19.4	dB	V _{IN} = ± 0.5V
MUTE terminal low-level input voltage	V _{ML}	-	-	0.5	V	
MUTE terminal high-level input voltage	V _{MH}	2.0	-	-	V	
CNT terminal low-level input voltage	V _{CNTL}	-	-	0.5	V	
CNT terminal high-level input voltage	V _{CNTH}	2.0	-	-	V	
LDIN terminal voltage (SLED input)	V _{LDIN}	-	0.1	0.3	V	CNT='L'
<Pre OP amp>						
Internal bias voltage	V _{BIN}	1.53	1.65	1.77	V	CNT='H'
Input offset voltage	V _{OFOP}	-6	0	6	mV	
Input bias current	I _{BOP}	-	-	300	nA	
High-level output voltage	V _{OHOP}	7.5	7.9	-	V	
low-level output voltage	V _{OLOP}	-	0.2	0.5	V	
Output driving current sink	I _{SI}	0.5	-	-	mA	
Output driving current source	I _{SO}	0.5	-	-	mA	
Slew rate	S _{ROP}	-	1	-	V/μs	100KHz square wave, 2Vp-p input
<Regulator>						
Output voltage	V _{reg}	4.79	5.04	5.29	V	I _{REG} =150mA
Load regulation	V _{RL}	-40	0	20	mV	I _{REG} =0~500mA, 5Vsetup
Supply voltage regulation	V _{VCC}	-20	10	40	mV	V _{CC} =5.5~14V, 5Vsetup
REG.P terminal voltage	V _{REGP}	2.28	2.4	2.52	V	

Package outlines : HSOP-M28

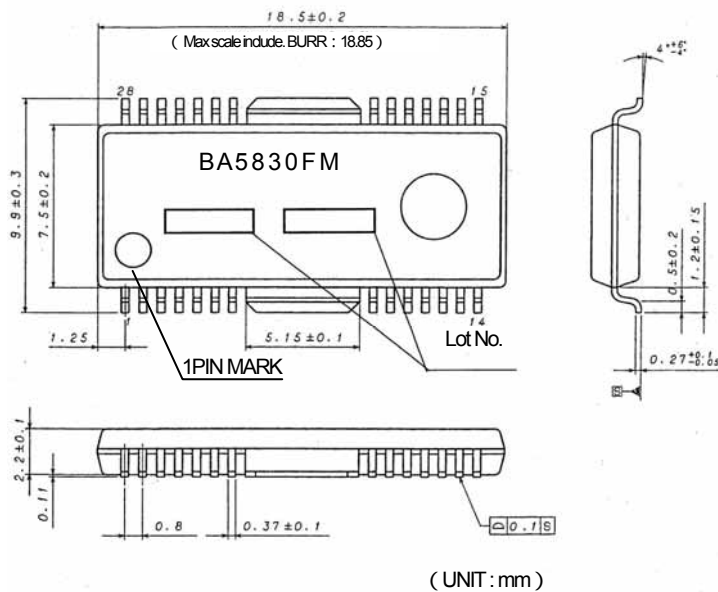

APPLICATION CIRCUIT DIAGRAM

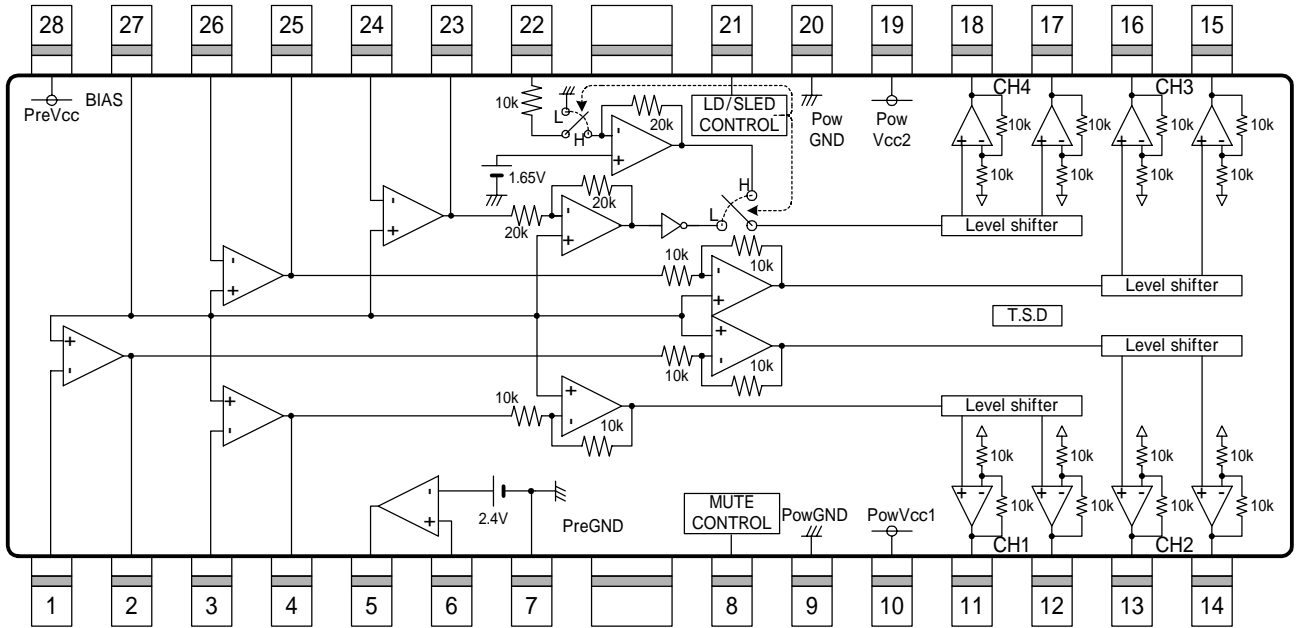

T.S.D : Thermal shutdown
Resistance unit : [Ω]

Pin Description

No.	Pin name	Pin description	No.	Pin name	Pin description
1	OPIN2(-)	CH2 Pre OP amplifier invert input	15	VO3(+)	Driver CH3 positive output
2	OPOUT2	CH2 Pre OP amplifier output	16	VO3(-)	Driver CH3 negative output
3	OPIN1(-)	CH1 Pre OP amplifier invert input	17	VO4(+)	Driver CH4 positive output
4	OPOUT1	CH1 Pre OP amplifier output	18	VO4(-)	Driver CH4 negative output
5	REG-B	Connect to external Tr. Base	19	PowVcc2	CH3,4 Power Block VCC
6	REG(+)	Regulator terminal of output feedback	20	PowGND	Power Block GND
7	PreGND	Pre Block and Regulator GND	21	CNT	Control terminal
8	MUTE	Mute terminal	22	LDIN	Loading input
9	PowGND	Power Block GND	23	OPOUTSL	SLED Pre OP amplifier output
10	PowVcc1	CH1,2 Power Block VCC	24	OPINSL(-)	SLED Pre OP amplifier invert input
11	VO1(-)	Driver CH1 negative output	25	OPOUT3	CH3 Pre OP amplifier output
12	VO1(+)	Driver CH1 positive output	26	OPIN3(-)	CH3 Pre OP amplifier invert input
13	VO2(-)	Driver CH2 negative output	27	BIAS	BIAS input
14	VO2(+)	Driver CH2 positive output	28	PreVcc	Pre-Block VCC

Note) When PIN2,4,22,25 is high("H"), the positive output pin of the driver is high("H") and the negative output pin is low("L").
When PIN23 is high("H"), the positive output pin of CH4 is low("L") and negative output pin is high("H").

Notes on use

- (1) Drivers can be switched mute ON/OFF by inputting combinations of H-level signal and L-level signal to MUTE and CNT terminal. There is the logic diagram in under table. (SL:Sled, LD>Loading)

INPUT		OUTPUT	
MUTE	CNT	CH1~3	CH4
H	H	MUTE OFF	LD ON
H	L	MUTE OFF	SL ON
L	H	MUTE ON	LD ON
L	L	MUTE ON	MUTE ON

- (2) When the BIAS terminal (27PIN) is lowered below 0.7V(typ.), the output is muted. In the normal state, this PIN must be pulled up above 1.3V. (When CNT is 'H', CH4 isn't muted.)
- (3) When the supply voltage reaches 3.8V (typ.) or lower, the output current is muted. When it rises to 4.0V (typ.) again, the driver circuit is activated.
- (4) The output is muted in the event of a thermal shut down, mute-on, or bias and Pre Vcc voltage drop. Only the driver is muted. When muted, output terminal becomes internal reference voltage (about (PowVcc-Vf)/2).
- (5) When a capacitance load is connected to the OP amplifier output, the amplifier phase margin decreases, which causes the peak or oscillator..When connecting such load, insert a resistance in series between the output and the capacitance load and take a full consideration for frequency characteristics, to prevent problems during practical use.
- (6) Connect a coupling capacitor (approx 0.1μF) between the power supplies at the root of this IC.
- (7) Connect the radiation fin to the external GND.
- (8) Avoid the short-circuits between: Output pin and Vcc, Output pin and GND, Output pins
If this caution is ignored, IC damage may cause smokes.
- (9) About absolute maximum ratings
Exceeding the absolute maximum ratings, such as the applied voltage or the operating temperature range, may cause permanent device damage. As these cases cannot be limited to the broken short mode or the open mode, if a special mode where the absolute maximum ratings may be exceeded is assumed, it is recommended to take mechanical safety measures such as attaching fuses.
- (10) About power supply lines
As a measure against the back current regenerated by a counter electromotive force of the motor, a capacitor to be used as a regenerated-current path can be installed between the power supply and GND and its capacitance value should be determined after careful check that any problems, for example, a leak capacitance of the electrolytic capacitor at low temperature, are not found in various characteristics.
- (11) About GND potential
The electric potential of the GND terminal must be kept lowest in the circuitry at any operation states.
- (12) About thermal design
With consideration of the power dissipation (Pd) under conditions of actual use, a thermal design provided with an enough margin should be done.
- (13) About operations in a strong electric field. When used in a strong electric field, note that a malfunction may occur.
- (14) ASO
When using this IC, the output Tr must be set not to exceed the values specified in the absolute maximum ratings and ASO.
- (15) Thermal shutdown circuit
This IC incorporates a thermal shutdown circuit (TSD circuit). When the chip temperature reaches the value shown below, the coil output to the motor will be set to open.
The thermal shutdown circuit is designed only to shut off the IC from a thermal runaway and not intended to protect or guarantee the entire IC functions. Therefore, users cannot assume that the TSD circuit once activated can be used continuously in the subsequent operations.

TSD ON Temperature [](typ.)	Hysteresis Temperature [](typ.)
175	25

- (16) About earth wiring patterns
When a small signal GND and a large current GND are provided, it is recommended that the large current GND pattern and the small signal GND pattern should be separated and grounded at a single point of the reference point of the set in order to prevent the voltage of the small signal GND from being affected by a voltage change caused by the resistance of the pattern wiring and the large current. Make sure that the GND wiring patterns of the external components will not change, too.
- (17) About each input terminal
This IC is a monolithic IC which has a P⁺ isolations and P substrate to isolate elements each other. This P layer and an N layer in each element form a PN junction to construct various parasitic elements. Due to the IC structure, the parasitic elements are inevitably created by the potential relationship. Activation of the parasitic elements can cause interference between circuits and may result in a malfunction or, consequently, a fatal damage. Therefore, make sure that the IC must not be used under conditions that may activate the parasitic elements, for example, applying the lower voltage than the ground level(GND, P substrate) to the input terminals.
Note that, while not applying the power supply voltage to the IC, any voltage must not be applied to the input terminals. In addition, do not apply the voltage to input terminals without applying the power supply voltage to the IC. Also while applying the power supply voltage, each input terminal must be the power supply voltage or less; or within the guaranteed values in the electric characteristics.

Notes

- No technical content pages of this document may be reproduced in any form or transmitted by any means without prior permission of ROHM CO.,LTD.
- The contents described herein are subject to change without notice. The specifications for the product described in this document are for reference only. Upon actual use, therefore, please request that specifications to be separately delivered.
- Application circuit diagrams and circuit constants contained herein are shown as examples of standard use and operation. Please pay careful attention to the peripheral conditions when designing circuits and deciding upon circuit constants in the set.
- Any data, including, but not limited to application circuit diagrams information, described herein are intended only as illustrations of such devices and not as the specifications for such devices. ROHM CO.,LTD. disclaims any warranty that any use of such devices shall be free from infringement of any third party's intellectual property rights or other proprietary rights, and further, assumes no liability of whatsoever nature in the event of any such infringement, or arising from or connected with or related to the use of such devices.
- Upon the sale of any such devices, other than for buyer's right to use such devices itself, resell or otherwise dispose of the same, no express or implied right or license to practice or commercially exploit any intellectual property rights or other proprietary rights owned or controlled by
- ROHM CO., LTD. is granted to any such buyer.
- Products listed in this document are no antiradiation design.

The products listed in this document are designed to be used with ordinary electronic equipment or devices (such as audio visual equipment, office-automation equipment, communications devices, electrical appliances and electronic toys).

Should you intend to use these products with equipment or devices which require an extremely high level of reliability and the malfunction of which would directly endanger human life (such as medical instruments, transportation equipment, aerospace machinery, nuclear-reactor controllers, fuel controllers and other safety devices), please be sure to consult with our sales representative in advance.

It is our top priority to supply products with the utmost quality and reliability. However, there is always a chance of failure due to unexpected factors. Therefore, please take into account the derating characteristics and allow for sufficient safety features, such as extra margin, anti-flammability, and fail-safe measures when designing in order to prevent possible accidents that may result in bodily harm or fire caused by component failure. ROHM cannot be held responsible for any damages arising from the use of the products under conditions out of the range of the specifications or due to non-compliance with the NOTES specified in this catalog.

Thank you for your accessing to ROHM product informations.

More detail product informations and catalogs are available, please contact your nearest sales office.

ROHM Customer Support System



THE AMERICAS / EUROPE / ASIA / JAPAN

www.rohm.com

Contact us : webmaster@rohm.co.jp

Looking for pricing, stock, or lifecycle information?

Click below to explore more details on WIN SOURCE:

-  [View BA5830FM-E2 on WIN SOURCE](#)
-  [Rohm Semiconductor](#) Information

Optimize Your Supply Chain with WIN SOURCE Solutions

-  Global Sourcing Solution
-  Obsolete Management
-  Cost Control Management
-  Shortage Management
-  Alternative Solution
-  Excess Inventory Management