



**THE DATASHEET OF
CY8C4127LQI-BL483**



PSoC™ 4 MCU with AIROC™ Bluetooth® LE

Based on Arm® Cortex®-M0

General description

PSoC™ 4 is a scalable and reconfigurable platform architecture for a family of programmable embedded system controllers with an Arm® Cortex®-M0 CPU. It combines programmable and reconfigurable analog and digital blocks with flexible automatic routing. The PSoC™ 4 CY8C41xx-BL MCU with AIROC™ Bluetooth® LE product family, based on this platform, is a combination of a microcontroller with an integrated Bluetooth® Low Energy, also known as Bluetooth® Smart, radio and subsystem (BLESS), compliant with Bluetooth® 4.2 specifications. The other features include digital programmable logic, high-performance analog-to-digital conversion (ADC), opamps with comparator mode, and standard communication and timing peripherals. The PSoC™ 4 CY8C41xx-BL MCU with AIROC™ Bluetooth® LE products will be fully upward compatible with members of the PSoC™ 4 platform for new applications and design needs. The programmable analog and digital subsystems allow flexibility and in-field tuning of the design.

Features

- 32-bit MCU subsystem
 - 24-MHz Arm® Cortex®-M0 CPU with single-cycle multiply
 - Up to 256 KB of flash with read accelerator
 - Up to 32 KB of SRAM
- Bluetooth® LE radio and subsystem
 - 2.4-GHz RF transceiver with Bluetooth® LE 4.2 support and 50-Ω antenna drive
 - Digital PHY
 - Link layer engine supporting master and slave modes
 - RF output power: -18 dBm to +3 dBm
 - RX sensitivity: -89 dBm
 - RX current: 16.4 mA
 - TX current: 15.6 mA at 0 dBm
 - Received Signal Strength Indication (RSSI): 1-dB resolution
- Programmable analog
 - Two opamps with reconfigurable high-drive external and high-bandwidth internal drive, comparator modes, and ADC input buffering capability; can operate in Deep-Sleep mode.
 - 12-bit, 806 ksps SAR ADC with differential and single-ended modes; channel sequencer with signal averaging
 - Two current DACs (IDACs) for general-purpose or capacitive sensing applications on any pin
 - Two low-power comparators that operate in Deep-Sleep mode
- Power management
 - Active mode: 1.7 mA at 3-MHz flash program execution
 - Deep-Sleep mode: 1.3 μA with watch crystal oscillator (WCO) on
 - Hibernate mode: 150 nA with RAM retention
 - Stop mode: 60 nA
- Capacitive sensing
 - Capacitive sigma-delta (CSD) provides best-in-class SNR (> 5:1) and liquid tolerance
 - Infineon-supplied software component makes capacitive-sensing design easy
 - Automatic hardware-tuning algorithm (SmartSense)
- Segment LCD drive
 - LCD drive supported on all pins (common or segment)
 - Operates in Deep-Sleep mode with four bits per pin memory

Features

- Serial communication
 - Two independent runtime reconfigurable serial communication blocks (SCBs) with reconfigurable I²C, SPI, or UART functionality
- Timing and pulse-width modulation
 - Four 16-bit timer, counter, pulse-width modulator (TCPWM) blocks
 - Center-aligned, Edge, and Pseudo-random modes
 - Comparator-based triggering of Kill signals for motor drive and other high-reliability digital logic applications
- Up to 36 programmable GPIOs
 - 7 mm × 7 mm 56-pin QFN package
 - 3.51 mm × 3.91 mm 68-ball CSP package
 - Any GPIO pin can be CAPSENSE™, LCD, analog, or digital
 - Two overvoltage-tolerant (OVT) pins; drive modes, strengths, and slew rates are programmable
- PSoC™ Creator design environment
 - Integrated design environment (IDE) provides schematic design entry and build (with analog and digital automatic routing)
 - API components for all fixed-function and programmable peripherals
- Industry-standard tool compatibility
 - After schematic entry, development can be done with Arm®-based industry-standard development tools

More information

More information

There is a wealth of data at www.infineon.com to help you to select the right PSoC™ device for your design, and to help you to quickly and effectively integrate the device into your design. For a comprehensive list of resources, see the introduction page for [Bluetooth® Low Energy products](#). Following is an abbreviated list for PSoC™ 4 CY8C4xxx-BL MCU with AIROC™ Bluetooth® LE:

- Overview: [PSoC™ portfolio](#)
- Product selectors: [PSoC™ 1](#), [PSoC™ 3](#), [PSoC™ 4](#), [PSoC™ 4 CY8C4xxx-BL MCU with AIROC™ Bluetooth® LE](#), [PSoC™ 5LP](#). In addition, PSoC™ Creator includes a device selection tool.
- Application notes: There are a large number of PSoC™ application notes covering a broad range of topics, from basic to advanced level. Recommended application notes for getting started with PSoC™ 4 CY8C4xxx-BL MCU with AIROC™ Bluetooth® LE are:
 - [AN91267](#): Getting started with PSoC™ 4 CY8C4xxx-BL MCU with AIROC™ Bluetooth® LE
 - [AN91184](#): PSoC™ 4 CY8C4xxx-BL MCU with AIROC™ Bluetooth® LE - Designing Bluetooth® LE applications
 - [AN91162](#): Creating a Bluetooth® LE Custom Profile
 - [AN97060](#): PSoC™ 4 CY8C4xxx-BL MCU with AIROC™ Bluetooth® LE and PRoC-BLE - Over-The-Air (OTA) Device Firmware Upgrade (DFU) guide
 - [AN91445](#): Antenna design and RF layout guidelines
 - [AN96841](#): Getting started With EZ-BLE module
 - [AN85951](#): PSoC™ 4 CAPSENSE™ design guide
 - [AN95089](#): PSoC™ 4/PRoC-Bluetooth® LE crystal oscillator selection and tuning techniques
 - [AN92584](#): Designing for low power and estimating battery life for Bluetooth® LE applications
- Technical reference manual (TRM) is in two documents:
 - [Architecture TRM](#) details each PSoC™ 4 CY8C4xxx-BL MCU with AIROC™ Bluetooth® LE functional block.
 - [Registers TRM](#) describes each of the PSoC™ 4 CY8C4xxx-BL MCU with AIROC™ Bluetooth® LE registers.
- Development kits:
 - [CY8CKIT-042-BLE-A](#) Pioneer Kit, is a flexible, Arduino-compatible, Bluetooth® LE development kit for PSoC™ 4 with AIROC™ Bluetooth® LE.
 - [CY8CKIT-142](#), PSoC™ 4 with AIROC™ Bluetooth® LE Module, features a PSoC™ 4 CY8C4xxx-BL MCU with AIROC™ Bluetooth® LE device, two crystals for the antenna matching network, a PCB antenna, and other passives, while providing access to all GPIOs of the device.
 - [CY8CKIT-143](#), PSoC™ 4 with AIROC™ Bluetooth® LE 256 KB module, features a PSoC™ 4 CY8C4xxx-BL MCU with AIROC™ Bluetooth® LE 256 KB device, two crystals for the antenna matching network, a PCB antenna, and other passives, while providing access to all GPIOs of the device.

The [MiniProg3](#) device provides an interface for flash programming and debug.

PSoC™ Creator

PSoC™ Creator is a free Windows-based Integrated Design Environment (IDE). It enables concurrent hardware and firmware design of PSoC™ 3, PSoC™ 4, and PSoC™ 5LP based systems. Create designs using classic, familiar schematic capture supported by over 100 pre-verified, production-ready PSoC™ Components; see the [list of component datasheets](#). With PSoC™ Creator, you can:

1. Drag and drop component icons to build your hardware system design in the main design workspace
2. Codesign your application firmware with the PSoC™ hardware, using the PSoC™ Creator IDE C compiler
3. Configure components using the configuration tools
4. Explore the library of 100+ components
5. Review component datasheets

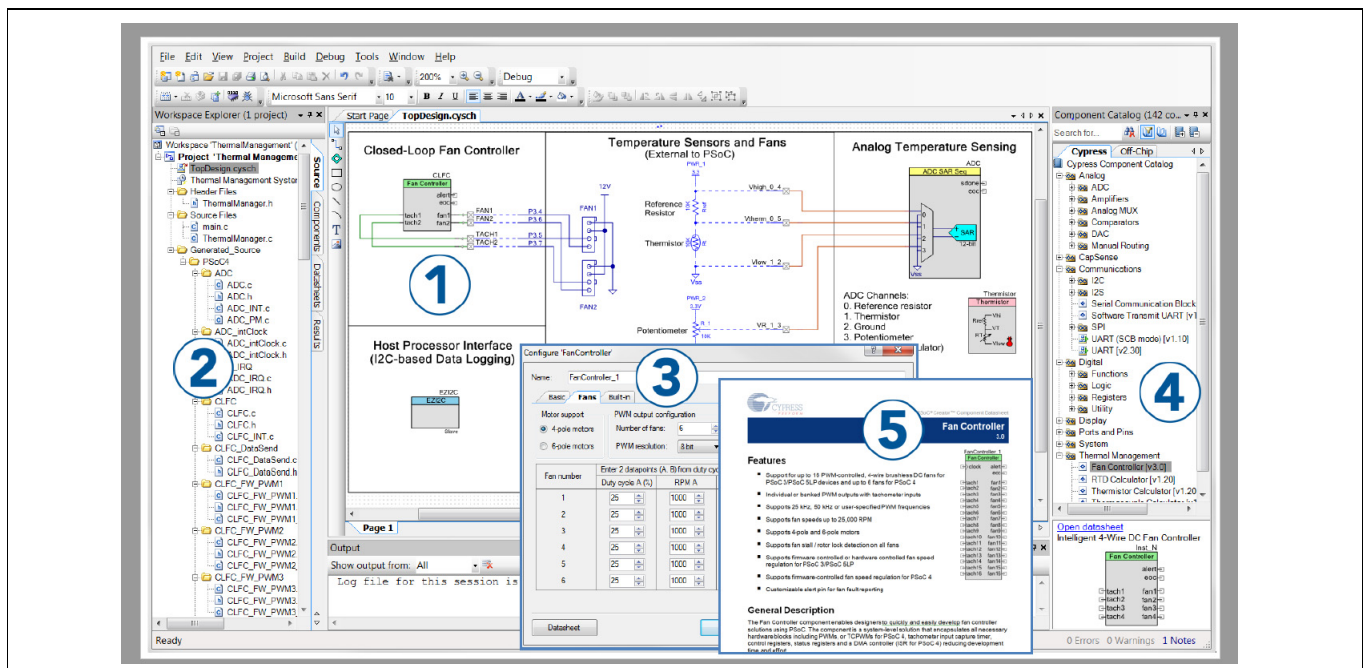

Figure 1 Multiple-sensor example project in PSoC™ Creator

Table of contents

| | |
|--|-----------|
| General description | 1 |
| Features | 1 |
| More information | 3 |
| PSoC™ Creator | 4 |
| Table of contents | 5 |
| Block diagram | 7 |
| 1 Functional definition | 8 |
| 1.1 CPU and memory subsystem | 8 |
| 1.1.1 CPU | 8 |
| 1.1.2 Flash | 8 |
| 1.1.3 SRAM | 8 |
| 1.1.4 SROM | 8 |
| 1.2 System resources | 8 |
| 1.2.1 Power system | 8 |
| 1.2.2 Clock system | 9 |
| 1.2.3 IMO clock source | 9 |
| 1.2.4 ILO clock source | 9 |
| 1.2.5 External crystal oscillator (ECO) | 9 |
| 1.2.6 Watch crystal oscillator (WCO) | 9 |
| 1.2.7 Watchdog timer | 9 |
| 1.2.8 Reset | 10 |
| 1.2.9 Voltage reference | 10 |
| 1.3 Bluetooth® smart radio and subsystem | 11 |
| 1.4 Analog blocks | 12 |
| 1.4.1 12-bit SAR ADC | 12 |
| 1.4.2 Opamps (CTBm block) | 12 |
| 1.4.3 Temperature sensor | 13 |
| 1.4.4 Low-power comparators | 13 |
| 1.5 Fixed-function digital | 13 |
| 1.5.1 Timer/counter/PWM block | 13 |
| 1.5.2 Serial Communication Blocks (SCB) | 13 |
| 1.6 GPIO | 14 |
| 1.7 Special-function peripherals | 15 |
| 1.7.1 LCD segment drive | 15 |
| 1.7.2 CAPSENSE™ | 15 |
| 2 Pinouts | 16 |
| 3 Power | 26 |
| 4 Development support | 27 |
| 4.1 Documentation | 27 |
| 4.2 Online | 27 |
| 4.3 Tools | 27 |
| 5 Electrical specifications | 28 |
| 5.1 Absolute maximum ratings | 28 |
| 5.2 Device level specifications | 29 |
| 5.2.1 GPIO | 32 |
| 5.2.2 XRES | 34 |
| 5.3 Analog peripherals | 35 |
| 5.3.1 Opamp | 35 |
| 5.3.2 Temperature sensor | 38 |
| 5.3.3 SAR ADC | 38 |
| 5.3.4 CSD | 39 |

Table of contents

| | |
|---|-----------|
| 5.4 Digital peripherals..... | 40 |
| 5.4.1 Timer | 40 |
| 5.4.2 Counter | 41 |
| 5.4.3 Pulse width modulation (PWM) | 42 |
| 5.4.4 I ² C | 43 |
| 5.4.5 LCD direct drive..... | 43 |
| 5.4.6 SPI specifications | 44 |
| 5.5 Memory..... | 45 |
| 5.6 System resources..... | 46 |
| 5.6.1 Power-on reset (POR) | 46 |
| 5.6.2 Voltage monitors | 46 |
| 5.6.3 SWD interface | 47 |
| 5.6.4 Internal main oscillator | 47 |
| 5.6.5 Internal low-speed oscillator | 48 |
| 6 Ordering information | 53 |
| 6.1 Ordering code definitions..... | 54 |
| 7 Packaging | 55 |
| 7.1 WLCSP compatibility | 57 |
| 8 Acronyms | 61 |
| 9 Document conventions..... | 65 |
| 9.1 Units of measure | 65 |
| Revision history | 66 |

Block diagram

Block diagram

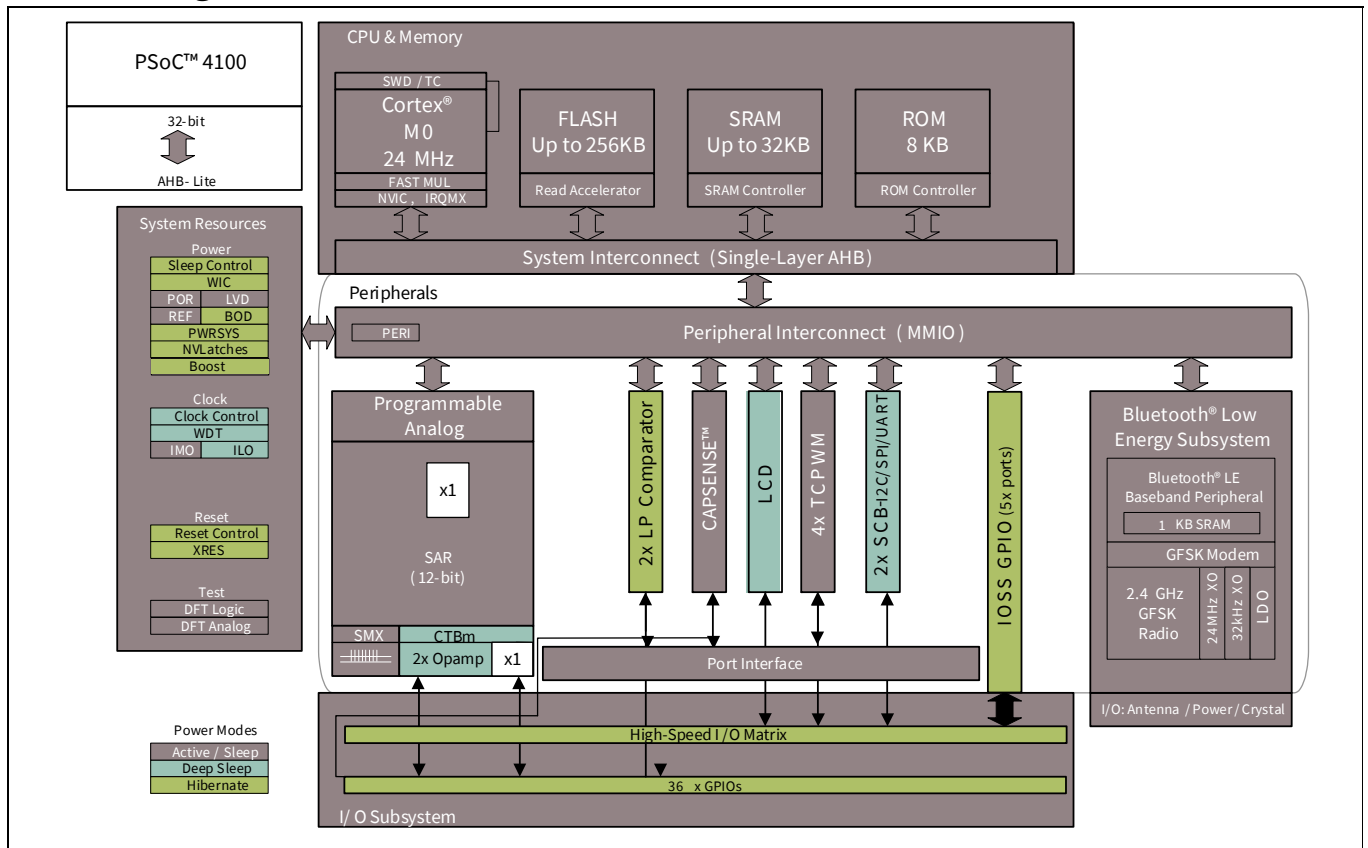

The PSoC™ 4 CY8C41xx-BL MCU with AIROC™ Bluetooth® LE devices include extensive support for programming, testing, debugging, and tracing both hardware and firmware.

The Arm® SWD interface supports all programming and debug features of the device.

Complete debug-on-chip functionality enables full-device debugging in the final system using the standard production device. It does not require special interfaces, debugging pods, simulators, or emulators. Only the standard programming connections are required to fully support debugging.

The PSoC™ Creator IDE provides fully integrated programming and debugging support for the PSoC™ 4 CY8C41xx-BL MCU with AIROC™ Bluetooth® LE devices. The SWD interface is fully compatible with industry-standard third-party tools. With the ability to disable debug features, very robust flash protection, and allowing customer-proprietary functionality to be implemented in on-chip programmable blocks, the PSoC™ 4 CY8C41xx-BL MCU with AIROC™ Bluetooth® LE family provides a level of security not possible with multi-chip application solutions or with microcontrollers.

Debug circuits are enabled by default and can only be disabled in firmware. If not enabled, the only way to re-enable them is to erase the entire device, clear flash protection, and reprogram the device with the new firmware that enables debugging.

Additionally, all device interfaces can be permanently disabled (device security) for applications concerned about phishing attacks due to a maliciously reprogrammed device or attempts to defeat security by starting and interrupting flash programming sequences. Because all programming, debug, and test interfaces are disabled when maximum device security is enabled, PSoC™ 4 CY8C41xx-BL MCU with AIROC™ Bluetooth® LE with device security enabled may not be returned for failure analysis. This is a trade-off the PSoC™ 4 CY8C41xx-BL MCU with AIROC™ Bluetooth® LE allows the customer to make.

1 Functional definition

1.1 CPU and memory subsystem

1.1.1 CPU

The Cortex®-M0 CPU in the PSoC™ 4 CY8C41xx-BL MCU with AIROC™ Bluetooth® LE is part of the 32-bit MCU subsystem, which is optimized for low-power operation with extensive clock gating. It mostly uses 16-bit instructions and executes a subset of the Thumb-2 instruction set. This enables fully compatible binary upward migration of the code to higher-performance processors such as Cortex®-M3 and M4. The implementation includes a hardware multiplier that provides a 32-bit result in one cycle. It includes a nested vectored interrupt controller (NVIC) block with 32 interrupt inputs and a wakeup interrupt controller (WIC). The WIC can wake the processor up from the Deep-Sleep mode, allowing power to the main processor to be switched off when the chip is in the Deep-Sleep mode. The Cortex®-M0 CPU provides a nonmaskable interrupt (NMI) input, which is made available to the user when it is not in use for system functions requested by the user.

The CPU also includes an SWD interface, which is a 2-wire form of JTAG; the debug configuration used for PSoC™ 4 CY8C41xx-BL MCU with AIROC™ Bluetooth® LE has four break-point (address) comparators and two watchpoint (data) comparators.

1.1.2 Flash

The PSoC™ 4 CY8C41xx-BL MCU with AIROC™ Bluetooth® LE device has a 128/256-KB flash module with a flash accelerator, tightly coupled to the CPU to improve average access times from the flash block. The flash block is designed to deliver with 0 WS access time at 24 MHz. The flash accelerator delivers 85% of single-cycle SRAM access performance on average. Part of the flash module can be used to emulate EEPROM operation if required.

During flash erase and programming operations (the maximum erase and program time is 20 ms per row), the Internal Main Oscillator (IMO) will be set to 48 MHz for the duration of the operation. This also applies to the emulated EEPROM. System design must take this into account because peripherals operating from different IMO frequencies will be affected. If it is critical that peripherals continue to operate with no change during flash programming, always set the IMO to 48 MHz and derive peripheral clocks by dividing down from this frequency

1.1.3 SRAM

SRAM memory is retained during Hibernate.

1.1.4 SRAM

The 8-KB supervisory ROM contains a library of executable functions for flash programming. These functions are accessed through supervisory calls (SVC) and enable in-system programming of the flash memory.

1.2 System resources

1.2.1 Power system

The power system is described in detail in the **“Power”** section on page 26. It provides an assurance that the voltage levels are as required for the respective modes, and can either delay the mode entry (on power-on reset (POR), for example) until voltage levels are as required or generate resets (brownout detect (BOD)) or interrupts when the power supply reaches a particular programmable level between 1.8 V and 4.5 V (low-voltage detect (LVD)). PSoC™ 4 CY8C41xx-BL MCU with AIROC™ Bluetooth® LE operates with a single external supply (1.71 V to 5.5 V without radio and 1.9 V to 5.5 V with radio). The device has five different power modes; transitions between these modes are managed by the power system. PSoC™ 4 CY8C41xx-BL MCU with AIROC™ Bluetooth® LE provides Sleep, Deep-Sleep, Hibernate, and Stop low-power modes. See the *Technical Reference Manual* for more details.

1.2.2 Clock system

The PSoC™ 4 CY8C41xx-BL MCU with AIROC™ Bluetooth® LE clock system is responsible for providing clocks to all subsystems that require clocks and for switching between different clock sources without glitching. In addition, the clock system ensures that no metastable conditions occur.

The clock system for PSoC™ 4 CY8C41xx-BL MCU with AIROC™ Bluetooth® LE consists of the internal main oscillator (IMO), the internal low-speed oscillator (ILO), the 24-MHz external crystal oscillator (ECO) and the 32-kHz watch crystal oscillator (WCO). In addition, an external clock may be supplied from a pin.

1.2.3 IMO clock source

The IMO is the primary source of internal clocking in PSoC™ 4 CY8C41xx-BL MCU with AIROC™ Bluetooth® LE. It is trimmed during testing to achieve the specified accuracy. Trim values are stored in nonvolatile latches (NVL). Additional trim settings from flash can be used to compensate for changes. The IMO default frequency is 24 MHz and it can be adjusted between 3 MHz to 48 MHz in steps of 1 MHz. The IMO tolerance with Infineon-provided calibration settings is $\pm 2\%$.

1.2.4 ILO clock source

The ILO is a very-low-power oscillator, which is primarily used to generate clocks for the peripheral operation in the Deep-Sleep mode. ILO-driven counters can be calibrated to the IMO to improve accuracy. A software component is provided, which does the calibration.

1.2.5 External crystal oscillator (ECO)

The ECO is used as the active clock for the Bluetooth® LE SS to meet the ± 50 -ppm clock accuracy of the Bluetooth® 4.2 Specification. PSoC™ 4 CY8C41xx-BL MCU with AIROC™ Bluetooth® LE includes a tunable load capacitor to tune the crystal-clock frequency by measuring the actual clock frequency. The high-accuracy ECO clock can also be used as a system clock.

1.2.6 Watch crystal oscillator (WCO)

The WCO is used as the sleep clock for the BLESS to meet the ± 500 -ppm clock accuracy of the Bluetooth® 4.2 Specification. The sleep clock provides an accurate sleep timing and enables wakeup at the specified advertisement and connection intervals. The WCO output can be used to realize the real-time clock (RTC) function in firmware.

1.2.7 Watchdog timer

A watchdog timer is implemented in the clock block running from the ILO or from the WCO; this allows the watchdog operation during Deep-Sleep and generates a watchdog reset if not serviced before the timeout occurs. The watchdog reset is recorded in the Reset Cause register. With the WCO and firmware, an accurate real-time clock (within the bounds of the 32-kHz crystal accuracy) can be realized.

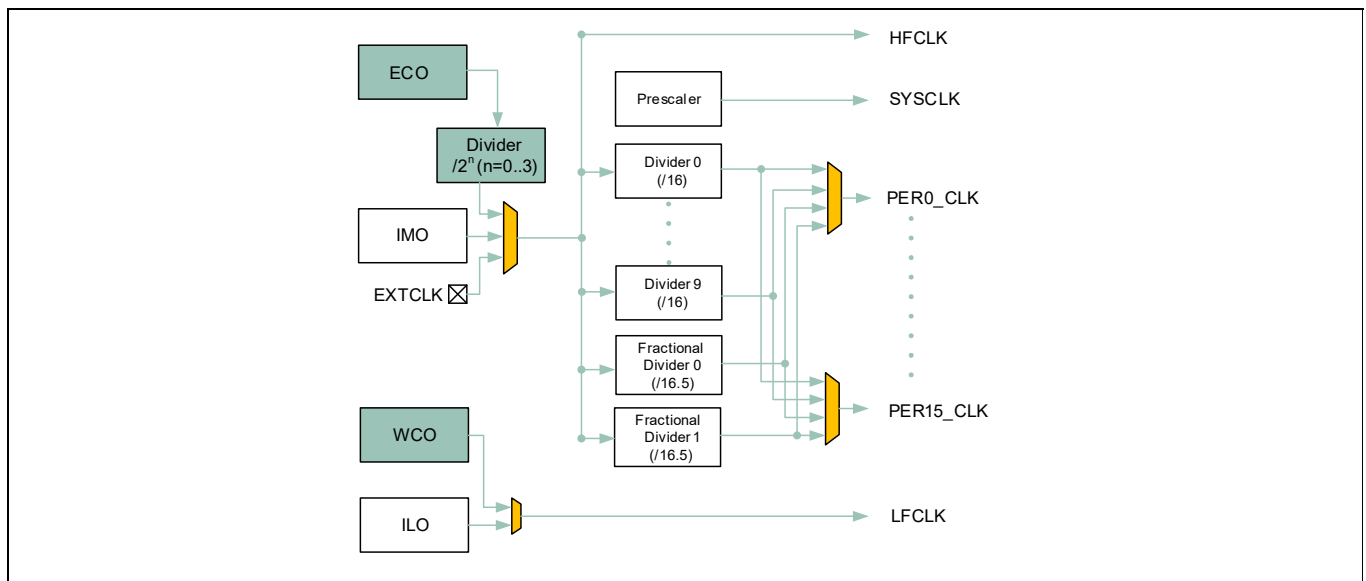

Figure 2 PSoC™ 4 CY8C41xx-BL MCU with AIROC™ Bluetooth® LE MCU clocking architecture

The HFCLK signal can be divided down (see [Figure 2](#)) to generate synchronous clocks for the UDBs, and the analog and digital peripherals. There are a total of 12 clock dividers for PSoC™ 4 CY8C41xx-BL MCU with AIROC™ Bluetooth® LE: ten with 16-bit divide capability and two with 16.5-bit divide capability. This allows the generation of 16 divided clock signals, which can be used by peripheral blocks. The analog clock leads the digital clocks to allow analog events to occur before the digital clock-related noise is generated. The 16-bit and 16.5-bit dividers allow a lot of flexibility in generating fine-grained frequency values and are fully supported in PSoC™ Creator.

1.2.8 Reset

PSoC™ 4 CY8C41xx-BL MCU with AIROC™ Bluetooth® LE can be reset from a variety of sources including a software reset. Reset events are asynchronous and guarantee reversion to a known state. The reset cause is recorded in a register, which is sticky through resets and allows the software to determine the cause of the reset. An XRES pin is reserved for an external reset to avoid complications with the configuration and multiple pin functions during power-on or reconfiguration. The XRES pin has an internal pull-up resistor that is always enabled.

1.2.9 Voltage reference

The PSoC™ 4 CY8C41xx-BL MCU with AIROC™ Bluetooth® LE reference system generates all internally required references. A one-percent voltage reference spec is provided for the 12-bit ADC. To allow better signal-to-noise ratios (SNR) and better absolute accuracy, it is possible to bypass the internal reference using a REF pin or use an external reference for the SAR. See [Table 21](#) for details.

1.3 Bluetooth® smart radio and subsystem

PSoC™ 4 CY8C41xx-BL MCU with AIROC™ Bluetooth® LE incorporates a Bluetooth® Smart subsystem that contains the Physical Layer (PHY) and Link Layer (LL) engines with an embedded AES-128 security engine. The physical layer consists of the digital PHY and the RF transceiver that transmits and receives GFSK packets at 1 Mbps over a 2.4-GHz ISM band, which is compliant with Bluetooth® Smart Bluetooth® Specification 4.2. The baseband controller is a composite hardware and firmware implementation that supports both master and slave modes. Key protocol elements, such as HCI and link control, are implemented in firmware. Time-critical functional blocks, such as encryption, CRC, data whitening, and access code correlation, are implemented in hardware (in the LL engine).

The RF transceiver contains an integrated balun, which provides a single-ended RF port pin to drive a 50-Ω antenna via a matching/filtering network. In the receive direction, this block converts the RF signal from the antenna to a digital bit stream after performing GFSK demodulation. In the transmit direction, this block performs GFSK modulation and then converts a digital baseband signal to a radio frequency before transmitting it to air through the antenna.

The Bluetooth® smart radio and subsystem (BLESS) requires a 1.9-V minimum supply (the range varies from 1.9 V to 5.5 V).

Key features of BLESS are as follows:

- Master and slave single-mode protocol stack with logical link control and adaptation protocol (L2CAP), attribute (ATT), and security manager (SM) protocols
- API access to generic attribute profile (GATT), generic access profile (GAP), and L2CAP
- L2CAP connection-oriented channel
- GAP features
 - Broadcaster, Observer, Peripheral, and Central roles
 - Security mode 1: Level 1, 2, 3, and 4
 - Security mode 2: Level 1 and 2
 - User-defined advertising data
 - Multiple bond support
- GATT features
 - GATT client and server
 - Supports GATT sub-procedures
 - 32-bit universally unique identifier (UUID)
- Security Manager (SM)
 - Pairing methods: Just works, Passkey Entry, Out of Band, and Numeric Comparison
 - Authenticated man-in-the-middle (MITM) protection and data signing
 - LE secure connections (Bluetooth® 4.2 feature)
- Link layer (LL)
 - Master and Slave roles
 - 128-bit AES engine
 - Encryption
 - Low-duty cycle advertising
 - LE ping
 - LE data packet length extension (Bluetooth® 4.2 feature)
 - Link layer privacy (with extended scanning filter policy, Bluetooth® 4.2 feature)
- Supports all SIG-adopted Bluetooth® LE profiles

1.4 Analog blocks

1.4.1 12-bit SAR ADC

The 12-bit, 806 ksp/s SAR ADC can operate at a maximum clock rate of 14.508 MHz and requires a minimum of 18 clocks at that frequency to do a 12-bit conversion.

The block functionality is augmented for the user by adding a reference buffer to it (trimmable to $\pm 1\%$) and by providing the choice of three internal voltage references, V_{DD} , $V_{DD}/2$, and V_{REF} (nominally 1.024 V), as well as an external reference through a REF pin. The sample-and-hold (S/H) aperture is programmable; it allows the gain bandwidth requirements of the amplifier driving the SAR inputs, which determine its settling time, to be relaxed if required. System performance will be 65 dB for true 12-bit precision if appropriate references are used and system noise levels permit it. To improve the performance in noisy conditions, it is possible to provide an external bypass (through a fixed pin location) for the internal reference amplifier.

The SAR is connected to a fixed set of pins through an 8-input sequencer. The sequencer cycles through the selected channels autonomously (sequencer scan) and does so with zero switching overhead (that is, the aggregate sampling bandwidth is equal to 806 ksp/s whether it is for a single channel or distributed over several channels). The sequencer switching is effected through a state machine or through firmware-driven switching. A feature provided by the sequencer is the buffering of each channel to reduce CPU interrupt-service requirements. To accommodate signals with varying source impedances and frequencies, it is possible to have different sample times programmable for each channel. Also, the signal range specification through a pair of range registers (low- and high-range values) is implemented with a corresponding out-of-range interrupt if the digitized value exceeds the programmed range; this allows fast detection of out-of-range values without having to wait for a sequencer scan to be completed and the CPU to read the values and check for out-of-range values in software.

The SAR is able to digitize the output of the on-chip temperature sensor for calibration and other temperature-dependent functions. The SAR is not available in Deep-Sleep and Hibernate modes as it requires a high-speed clock (up to 18 MHz). The SAR operating range is 1.71 V to 5.5 V.

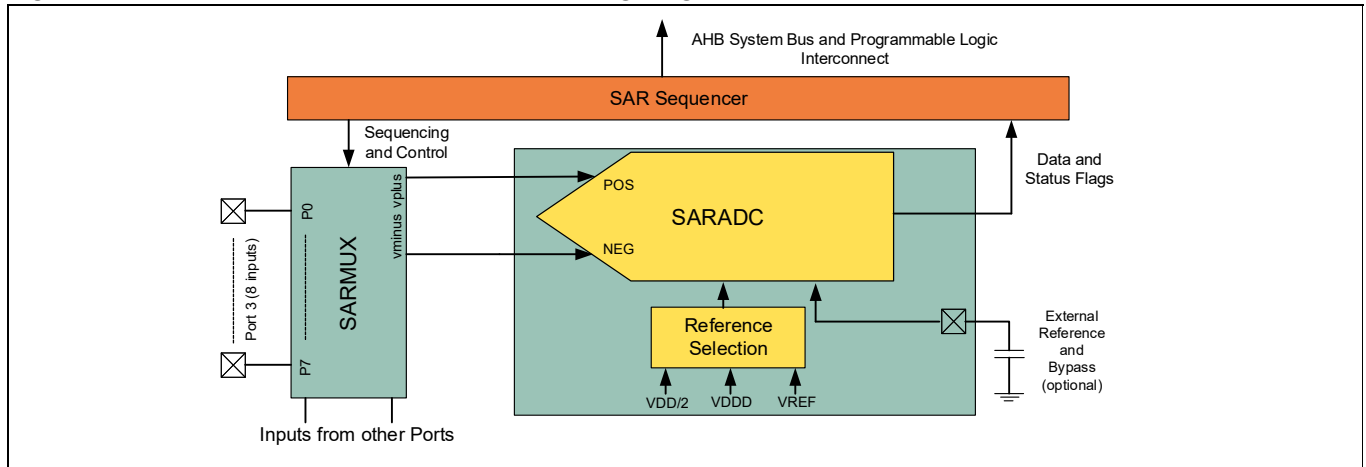

Figure 3 SAR ADC system diagram

1.4.2 Opamps (CTBm block)

PSoC™ 4 CY8C41xx-BL MCU with AIROC™ Bluetooth® LE has two opamps with comparator modes, which allow most common analog functions to be performed on-chip, eliminating external components. PGAs, voltage buffers, filters, transimpedance amplifiers, and other functions can be realized with external passives saving power, cost, and space. The on-chip opamps are designed with enough bandwidth to drive the sample-and-hold circuit of the ADC without requiring external buffering.

1.4.3 Temperature sensor

PSoC™ 4 CY8C41xx-BL MCU with AIROC™ Bluetooth® LE has an on-chip temperature sensor. This consists of a diode, which is biased by a current source that can be disabled to save power. The temperature sensor is connected to the ADC, which digitizes the reading and produces a temperature value by using an Infineon-supplied software that includes calibration and linearization.

1.4.4 Low-power comparators

PSoC™ 4 CY8C41xx-BL MCU with AIROC™ Bluetooth® LE has a pair of low-power comparators, which can also operate in Deep-Sleep and Hibernate modes. This allows the analog system blocks to be disabled while retaining the ability to monitor external voltage levels during low-power modes. The comparator outputs are normally synchronized to avoid metastability unless operating in an asynchronous power mode (Hibernate) where the system wake-up circuit is activated by a comparator-switch event.

1.5 Fixed-function digital

1.5.1 Timer/counter/PWM block

The timer/counter/PWM block consists of four 16-bit counters with user-programmable period length. There is a capture register to record the count value at the time of an event (which may be an I/O event), a period register which is used to either stop or auto-reload the counter when its count is equal to the period register, and compare registers to generate compare value signals which are used as PWM duty cycle outputs. The block also provides true and complementary outputs with programmable offset between them to allow the use as deadband programmable complementary PWM outputs. It also has a kill input to force outputs to a predetermined state; for example, this is used in motor-drive systems when an overcurrent state is indicated and the PWMs driving the FETs need to be shut off immediately with no time for software intervention.

1.5.2 Serial Communication Blocks (SCB)

PSoC™ 4 CY8C41xx-BL MCU with AIROC™ Bluetooth® LE has two SCBs, each of which can implement an I²C, UART, or SPI interface.

I²C mode: The hardware I²C block implements a full multi-master and slave interface (it is capable of multimaster arbitration). This block is capable of operating at speeds of up to 1 Mbps (Fast-Mode Plus) and has flexible buffering options to reduce the interrupt overhead and latency for the CPU. It also supports EzI²C that creates a mailbox address range in the memory of PSoC™ 4 CY8C41xx-BL MCU with AIROC™ Bluetooth® LE and effectively reduces the I²C communication to reading from and writing to an array in the memory. In addition, the block supports an 8-deep FIFO for receive and transmit, which, by increasing the time given for the CPU to read the data, greatly reduces the need for clock stretching caused by the CPU not having read the data on time. The FIFO mode is available in all channels and is very useful in the absence of DMA.

The I²C peripheral is compatible with I²C Standard-mode, Fast-mode, and Fast-Mode Plus devices as defined in the NXP I²C-bus specification and user manual (UM10204). The I²C bus I/O is implemented with GPIOs in open-drain modes.

SCB1 is fully compliant with Standard-mode (100 kHz), Fast-mode (400 kHz), and Fast-Mode Plus (1 MHz) I²C signaling specifications when routed to GPIO pins P5.0 and P5.1, except for hot swap capability during I²C active communication. The remaining GPIOs do not meet the hot-swap specification (V_{DD} off; draw < 10- μ A current) for Fast mode and Fast-Mode Plus, I_{OL} spec (20 mA) for Fast-Mode Plus, hysteresis spec ($0.05 \times V_{DD}$) for Fast mode and Fast-Mode Plus, and minimum fall-time spec for Fast mode and Fast-Mode Plus.

- GPIO cells, including P5.0 and P5.1, cannot be hot-swapped or powered up independent of the rest of the I²C system.
- The GPIO pins P5.0 and P5.1 are overvoltage-tolerant but cannot be hot-swapped or powered up independent of the rest of the I²C system.
- Fast-Mode Plus has an I_{OL} specification of 20 mA at a V_{OL} of 0.4 V. The GPIO cells can sink a maximum of 8 mA I_{OL} with a V_{OL} maximum of 0.6 V.

Functional definition

- Fast mode and Fast-Mode Plus specify minimum Fall times, which are not met with the GPIO cell; the Slow-Strong mode can help meet this spec depending on the bus load.

UART mode: This is a full-feature UART operating at up to 1 Mbps. It supports automotive single-wire interface (LIN), infrared interface (IrDA), and SmartCard (ISO7816) protocols, all of which are minor variants of the basic UART protocol. In addition, it supports the 9-bit multiprocessor mode that allows the addressing of peripherals connected over common RX and TX lines. Common UART functions such as parity error, break detect, and frame error are supported. An 8-deep FIFO allows much greater CPU service latencies to be tolerated.

SPI mode: The SPI mode supports full Motorola SPI, TI Secure Simple Pairing (SSP) (essentially adds a start pulse that is used to synchronize SPI Codex), and National Microwire (half-duplex form of SPI). The SPI block can use the FIFO for transmit and receive.

1.6 GPIO

PSoC™ 4 CY8C41xx-BL MCU with AIROC™ Bluetooth® LE has 36 GPIOs. The GPIO block implements the following:

- Eight drive-strength modes:
 - Analog input mode (input and output buffers disabled)
 - Input only
 - Weak pull-up with strong pull-down
 - Strong pull-up with weak pull-down
 - Open drain with strong pull-down
 - Open drain with strong pull-up
 - Strong pull-up with strong pull-down
 - Weak pull-up with weak pull-down
- Input threshold select (CMOS or LVTTTL)
- Pins 0 and 1 of Port 5 are overvoltage-tolerant Pins
- Individual control of input and output buffer enabling/disabling in addition to drive-strength modes
- Hold mode for latching the previous state (used for retaining the I/O state in Deep-Sleep and Hibernate modes)
- Selectable slew rates for dV/dt-related noise control to improve EMI

The pins are organized in logical entities called ports, which are 8-bit in width. During power-on and reset, the blocks are forced to the disable state so as not to crowbar any inputs and/or cause excess turn-on current. A multiplexing network known as a high-speed I/O matrix (HSIOM) is used to multiplex between various signals that may connect to an I/O pin. Pin locations for fixed-function peripherals are also fixed to reduce internal multiplexing complexity (these signals do not go through the DSI network). DSI signals are not affected by this and any pin may be routed to any UDB through the DSI network.

Data output and pin-state registers store, respectively, the values to be driven on the pins and the states of the pins themselves. Every I/O pin can generate an interrupt if so enabled and each I/O port has an interrupt request (IRQ) and interrupt service routine (ISR) vector associated with it (5 for PSoC™ 4 CY8C41xx-BL MCU with AIROC™ Bluetooth® LE since it has 4.5 ports).

1.7 Special-function peripherals

1.7.1 LCD segment drive

PSoC™ 4 CY8C41xx-BL MCU with AIROC™ Bluetooth® LE has an LCD controller, which can drive up to four commons and up to 32 segments. It uses full digital methods to drive the LCD segments requiring no generation of internal LCD voltages. The two methods used are referred to as digital correlation and PWM.

The digital correlation method modulates the frequency and levels of the common and segment signals to generate the highest RMS voltage across a segment to light it up or to keep the RMS signal zero. This method is good for STN displays but may result in reduced contrast with TN (cheaper) displays.

The PWM method drives the panel with PWM signals to effectively use the capacitance of the panel to provide the integration of the modulated pulse-width to generate the desired LCD voltage. This method results in higher power consumption but can result in better results when driving TN displays. LCD operation is supported during Deep-Sleep mode, refreshing a small display buffer (four bits; one 32-bit register per port).

1.7.2 CAPSENSE™

CAPSENSE™ is supported on all pins in PSoC™ 4 CY8C41xx-BL MCU with AIROC™ Bluetooth® LE through a capacitive sigma-delta (CSD) block that can be connected to any pin through an analog mux bus that any GPIO pin can be connected to via an Analog switch. CAPSENSE™ function can thus be provided on any pin or group of pins in a system under software control. A component is provided for the CAPSENSE™ block to make it easy for the user.

The shield voltage can be driven on another mux bus to provide liquid-tolerance capability. Liquid tolerance is provided by driving the shield electrode in phase with the sense electrode to keep the shield capacitance from attenuating the sensed input.

The CAPSENSE™ block has two IDACs which can be used for general purposes if CAPSENSE™ is not being used (both IDACs are available in that case) or if CAPSENSE™ is used without liquid tolerance (one IDAC is available).

2 Pinouts

Table 1, **Table 2**, and **Table 3** show pin list for 56-pin QFN, 68-ball WLCSP, and 76-ball WLCSP packages of PSoC™ 4 CY8C41xx-BL MCU with AIROC™ Bluetooth® LE respectively. Port 2 consists of the high-speed analog inputs for the SAR mux. All pins support CSD CAPSENSE™ and analog mux bus connections.

Table 1 PSoC™ 4 CY8C41xx-BL MCU with AIROC™ Bluetooth® LE pin list (56-pin QFN package)

| Pin | Name | Type | Description |
|-----|--------------|---------|--|
| 1 | VDDD | POWER | 1.71-V to 5.5-V digital supply |
| 2 | XTAL32O/P6.0 | CLOCK | 32.768-kHz crystal |
| 3 | XTAL32I/P6.1 | CLOCK | 32.768-kHz crystal or external clock input |
| 4 | XRES | RESET | Reset, active LOW |
| 5 | P4.0 | GPIO | Port 4 Pin 0, lcd, csd |
| 6 | P4.1 | GPIO | Port 4 Pin 1, lcd, csd |
| 7 | P5.0 | GPIO | Port 5 Pin 0, lcd, csd, overvoltage-tolerant |
| 8 | P5.1 | GPIO | Port 5 Pin 1, lcd, csd, overvoltage-tolerant |
| 9 | VSSD | GROUND | Digital ground |
| 10 | VDDR | POWER | 1.9-V to 5.5-V radio supply |
| 11 | GANT1 | GROUND | Antenna shielding ground |
| 12 | ANT | ANTENNA | Antenna pin |
| 13 | GANT2 | GROUND | Antenna shielding ground |
| 14 | VDDR | POWER | 1.9-V to 5.5-V radio supply |
| 15 | VDDR | POWER | 1.9-V to 5.5-V radio supply |
| 16 | XTAL24I | CLOCK | 24-MHz crystal or external clock input |
| 17 | XTAL24O | CLOCK | 24-MHz crystal |
| 18 | VDDR | POWER | 1.9-V to 5.5-V radio supply |
| 19 | P0.0 | GPIO | Port 0 Pin 0, lcd, csd |
| 20 | P0.1 | GPIO | Port 0 Pin 1, lcd, csd |
| 21 | P0.2 | GPIO | Port 0 Pin 2, lcd, csd |
| 22 | P0.3 | GPIO | Port 0 Pin 3, lcd, csd |
| 23 | VDDD | POWER | 1.71-V to 5.5-V digital supply |
| 24 | P0.4 | GPIO | Port 0 Pin 4, lcd, csd |
| 25 | P0.5 | GPIO | Port 0 Pin 5, lcd, csd |
| 26 | P0.6 | GPIO | Port 0 Pin 6, lcd, csd |
| 27 | P0.7 | GPIO | Port 0 Pin 7, lcd, csd |
| 28 | P1.0 | GPIO | Port 1 Pin 0, lcd, csd |
| 29 | P1.1 | GPIO | Port 1 Pin 1, lcd, csd |
| 30 | P1.2 | GPIO | Port 1 Pin 2, lcd, csd |
| 31 | P1.3 | GPIO | Port 1 Pin 3, lcd, csd |
| 32 | P1.4 | GPIO | Port 1 Pin 4, lcd, csd |
| 33 | P1.5 | GPIO | Port 1 Pin 5, lcd, csd |
| 34 | P1.6 | GPIO | Port 1 Pin 6, lcd, csd |
| 35 | P1.7 | GPIO | Port 1 Pin 7, lcd, csd |

Pinouts

Table 1 **PSoC™ 4 CY8C41xx-BL MCU with AIROC™ Bluetooth® LE pin list**
(56-pin QFN package) (continued)

| Pin | Name | Type | Description |
|-----|------|--------|---|
| 36 | VDDA | POWER | 1.71-V to 5.5-V analog supply |
| 37 | P2.0 | GPIO | Port 2 Pin 0, lcd, csd |
| 38 | P2.1 | GPIO | Port 2 Pin 1, lcd, csd |
| 39 | P2.2 | GPIO | Port 2 Pin 2, lcd, csd |
| 40 | P2.3 | GPIO | Port 2 Pin 3, lcd, csd |
| 41 | P2.4 | GPIO | Port 2 Pin 4, lcd, csd |
| 42 | P2.5 | GPIO | Port 2 Pin 5, lcd, csd |
| 43 | P2.6 | GPIO | Port 2 Pin 6, lcd, csd |
| 44 | P2.7 | GPIO | Port 2 Pin 7, lcd, csd |
| 45 | VREF | REF | External reference input or bypass capacitor |
| 46 | VDDA | POWER | 1.71-V to 5.5-V analog supply |
| 47 | P3.0 | GPIO | Port 3 Pin 0, lcd, csd |
| 48 | P3.1 | GPIO | Port 3 Pin 1, lcd, csd |
| 49 | P3.2 | GPIO | Port 3 Pin 2, lcd, csd |
| 50 | P3.3 | GPIO | Port 3 Pin 3, lcd, csd |
| 51 | P3.4 | GPIO | Port 3 Pin 4, lcd, csd |
| 52 | P3.5 | GPIO | Port 3 Pin 5, lcd, csd |
| 53 | P3.6 | GPIO | Port 3 Pin 6, lcd, csd |
| 54 | P3.7 | GPIO | Port 3 Pin 7, lcd, csd |
| 55 | VSSA | GROUND | Analog ground |
| 56 | VCCD | POWER | Regulated 1.8-V supply, connect to 1-μF capacitor |
| 57 | EPAD | GROUND | Ground paddle for the QFN package |

Table 2 **PSoC™ 4 CY8C41xx-BL MCU with AIROC™ Bluetooth® LE pin list**
(68-ball WLCSP package)

| Pin | Name | Type | Pin description |
|-----|------|--------|---|
| A1 | VREF | REF | External reference input or bypass capacitor |
| A2 | VSSA | GROUND | Analog ground |
| A3 | P3.3 | GPIO | Port 3 Pin 3, lcd, csd |
| A4 | P3.7 | GPIO | Port 3 Pin 7, lcd, csd |
| A5 | VSSD | GROUND | Digital ground |
| A6 | VSSA | GROUND | Analog ground |
| A7 | VCCD | POWER | Regulated 1.8-V supply, connect to 1-μF capacitor |
| A8 | VDDD | POWER | 1.71-V to 5.5-V radio supply |
| B1 | P2.3 | GPI | Port 2 Pin 3, lcd, csd |
| B2 | VSSA | GROUND | Analog ground |
| B3 | P2.7 | GPIO | Port 2 Pin 7, lcd, csd |
| B4 | P3.4 | GPIO | Port 3 Pin 4, lcd, csd |
| B5 | P3.5 | GPIO | Port 3 Pin 5, lcd, csd |

Pinouts

Table 2 **PSoC™ 4 CY8C41xx-BL MCU with AIROC™ Bluetooth® LE pin list**
(68-ball WLCSP package) *(continued)*

| Pin | Name | Type | Pin description |
|-----|--------------|--------|--|
| B6 | P3.6 | GPIO | Port 3 Pin 6, lcd, csd |
| B7 | XTAL32I/P6.1 | CLOCK | 32.768-kHz crystal or external clock input |
| B8 | XTAL32O/P6.0 | CLOCK | 32.768-kHz crystal |
| C1 | VSSA | GROUND | Analog ground |
| C2 | P2.2 | GPIO | Port 2 Pin 2, lcd, csd |
| C3 | P2.6 | GPIO | Port 2 Pin 6, lcd, csd |
| C4 | P3.0 | GPIO | Port 3 Pin 0, lcd, csd |
| C5 | P3.1 | GPIO | Port 3 Pin 1, lcd, csd |
| C6 | P3.2 | GPIO | Port 3 Pin 2, lcd, csd |
| C7 | XRES | RESET | Reset, active LOW |
| C8 | P4.0 | GPIO | Port 4 Pin 0, lcd, csd |
| D1 | P1.7 | GPIO | Port 1 Pin 7, lcd, csd |
| D2 | VDDA | POWER | 1.71-V to 5.5-V analog supply |
| D3 | P2.0 | GPIO | Port 2 Pin 0, lcd, csd |
| D4 | P2.1 | GPIO | Port 2 Pin 1, lcd, csd |
| D5 | P2.5 | GPIO | Port 2 Pin 5, lcd, csd |
| D6 | VSSD | GROUND | Digital ground |
| D7 | P4.1 | GPIO | Port 4 Pin 1, lcd, csd |
| D8 | P5.0 | GPIO | Port 5 Pin 0, lcd, csd |
| E1 | P1.2 | GPIO | Port 1 Pin 2, lcd, csd |
| E2 | P1.3 | GPIO | Port 1 Pin 3, lcd, csd |
| E3 | P1.4 | GPIO | Port 1 Pin 4, lcd, csd |
| E4 | P1.5 | GPIO | Port 1 Pin 5, lcd, csd |
| E5 | P1.6 | GPIO | Port 1 Pin 6, lcd, csd |
| E6 | P2.4 | GPIO | Port 2 Pin 4, lcd, csd |
| E7 | P5.1 | GPIO | Port 5 Pin 1, lcd, csd |
| E8 | VSSD | GROUND | Digital ground |
| F1 | VSSD | GROUND | Digital ground |
| F2 | P0.7 | GPIO | Port 0 Pin 7, lcd, csd |
| F3 | P0.3 | GPIO | Port 0 Pin 3, lcd, csd |
| F4 | P1.0 | GPIO | Port 1 Pin 0, lcd, csd |
| F5 | P1.1 | GPIO | Port 1 Pin 1, lcd, csd |
| F6 | VSSR | GROUND | Radio ground |
| F7 | VSSR | GROUND | Radio ground |
| F8 | VDDR | POWER | 1.9-V to 5.5-V radio supply |
| G1 | P0.6 | GPIO | Port 0 Pin 6, lcd, csd |
| G2 | VDDD | POWER | 1.71-V to 5.5-V digital supply |
| G3 | P0.2 | GPIO | Port 0 Pin 2, lcd, csd |
| G4 | VSSD | GROUND | Digital ground |

Pinouts

Table 2 PSoC™ 4 CY8C41xx-BL MCU with AIROC™ Bluetooth® LE pin list
(68-ball WLCSP package) (continued)

| Pin | Name | Type | Pin description |
|-----|------------|---------|--|
| G5 | VSSR | GROUND | Radio ground |
| G6 | VSSR | GROUND | Radio ground |
| G7 | GANT | GROUND | Antenna shielding ground |
| G8 | VSSR | GROUND | Radio ground |
| H1 | P0.5 | GPIO | Port 0 Pin 5, lcd, csd |
| H2 | P0.1 | GPIO | Port 0 Pin 1, lcd, csd |
| H3 | XTAL24O | CLOCK | 24-MHz crystal |
| H4 | XTAL24I | CLOCK | 24-MHz crystal or external clock input |
| H5 | VSSR | GROUND | Radio ground |
| H6 | VSSR | GROUND | Radio ground |
| H7 | ANT | ANTENNA | Antenna pin |
| J1 | P0.4 | GPIO | Port 0 Pin 4, lcd, csd |
| J2 | P0.0 | GPIO | Port 0 Pin 0, lcd, csd |
| J3 | VDDR | POWER | 1.9-V to 5.5-V radio supply |
| J6 | VDDR | POWER | 1.9-V to 5.5-V radio supply |
| J7 | No Connect | - | - |

Table 3 PSoC™ 4 CY8C41xx-BL MCU with AIROC™ Bluetooth® LE pin list
(76-ball WLCSP package)

| Pin | Name | Type | Description |
|-----|--------------|---------|---|
| A1 | NC | NC | Do not connect |
| A2 | VREF | REF | External reference input or bypass capacitor |
| A3 | VSSA | GROUND | Analog ground |
| A4 | P3.3 | GPIO | Port 3 Pin 3, analog/digital/lcd/csd |
| A5 | P3.7 | GPIO | Port 3 Pin 7, analog/digital/lcd/csd |
| A6 | VSSD | GROUND | Digital ground |
| A7 | VSSA | GROUND | Analog ground |
| A8 | VCCD | POWER | Regulated 1.8-V supply, connect to 1-μF capacitor |
| A9 | VDDD | POWER | 1.71-V to 5.5-V digital supply |
| B1 | NB | NO BALL | No Ball |
| B2 | P2.3 | GPIO | Port 2 Pin 3, analog/digital/lcd/csd |
| B3 | VSSA | GROUND | Analog ground |
| B4 | P2.7 | GPIO | Port 2 Pin 7, analog/digital/lcd/csd |
| B5 | P3.4 | GPIO | Port 3 Pin 4, analog/digital/lcd/csd |
| B6 | P3.5 | GPIO | Port 3 Pin 5, analog/digital/lcd/csd |
| B7 | P3.6 | GPIO | Port 3 Pin 6, analog/digital/lcd/csd |
| B8 | XTAL32I/P6.1 | CLOCK | 32.768-kHz crystal or external clock input |
| B9 | XTAL32O/P6.0 | CLOCK | 32.768-kHz crystal |
| C1 | NC | NC | Do not connect |

Pinouts

Table 3 **PSoC™ 4 CY8C41xx-BL MCU with AIROC™ Bluetooth® LE pin list**
(76-ball WLCSP package) *(continued)*

| Pin | Name | Type | Description |
|-----|------|--------|--------------------------------------|
| C2 | VSSA | GROUND | Analog ground |
| C3 | P2.2 | GPIO | Port 2 Pin 2, analog/digital/lcd/csd |
| C4 | P2.6 | GPIO | Port 2 Pin 6, analog/digital/lcd/csd |
| C5 | P3.0 | GPIO | Port 3 Pin 0, analog/digital/lcd/csd |
| C6 | P3.1 | GPIO | Port 3 Pin 1, analog/digital/lcd/csd |
| C7 | P3.2 | GPIO | Port 3 Pin 2, analog/digital/lcd/csd |
| C8 | XRES | RESET | Reset, active LOW |
| C9 | P4.0 | GPIO | Port 4 Pin 0, analog/digital/lcd/csd |
| D1 | NC | NC | Do not connect |
| D2 | P1.7 | GPIO | Port 1 Pin 7, analog/digital/lcd/csd |
| D3 | VDDA | POWER | 1.71-V to 5.5-V analog supply |
| D4 | P2.0 | GPIO | Port 2 Pin 0, analog/digital/lcd/csd |
| D5 | P2.1 | GPIO | Port 2 Pin 1, analog/digital/lcd/csd |
| D6 | P2.5 | GPIO | Port 2 Pin 5, analog/digital/lcd/csd |
| D7 | VSSD | GROUND | Digital ground |
| D8 | P4.1 | GPIO | Port 4 Pin 1, analog/digital/lcd/csd |
| D9 | P5.0 | GPIO | Port 5 Pin 0, analog/digital/lcd/csd |
| E1 | NC | NC | Do not connect |
| E2 | P1.2 | GPIO | Port 1 Pin 2, analog/digital/lcd/csd |
| E3 | P1.3 | GPIO | Port 1 Pin 3, analog/digital/lcd/csd |
| E4 | P1.4 | GPIO | Port 1 Pin 4, analog/digital/lcd/csd |
| E5 | P1.5 | GPIO | Port 1 Pin 5, analog/digital/lcd/csd |
| E6 | P1.6 | GPIO | Port 1 Pin 6, analog/digital/lcd/csd |
| E7 | P2.4 | GPIO | Port 2 Pin 4, analog/digital/lcd/csd |
| E8 | P5.1 | GPIO | Port 5 Pin 1, analog/digital/lcd/csd |
| E9 | VSSD | GROUND | Digital ground |
| F1 | NC | NC | Do not connect |
| F2 | VSSD | GROUND | Digital ground |
| F3 | P0.7 | GPIO | Port 0 Pin 7, analog/digital/lcd/csd |
| F4 | P0.3 | GPIO | Port 0 Pin 3, analog/digital/lcd/csd |
| F5 | P1.0 | GPIO | Port 1 Pin 0, analog/digital/lcd/csd |
| F6 | P1.1 | GPIO | Port 1 Pin 1, analog/digital/lcd/csd |
| F7 | VSSR | GROUND | Radio ground |
| F8 | VSSR | GROUND | Radio ground |
| F9 | VDDR | POWER | 1.9-V to 5.5-V radio supply |
| G1 | NC | NC | Do not connect |
| G2 | P0.6 | GPIO | Port 0 Pin 6, analog/digital/lcd/csd |
| G3 | VDDD | POWER | 1.71-V to 5.5-V digital supply |
| G4 | P0.2 | GPIO | Port 0 Pin 2, analog/digital/lcd/csd |

Pinouts

Table 3 PSoC™ 4 CY8C41xx-BL MCU with AIROC™ Bluetooth® LE pin list
 (76-ball WLCSP package) (continued)

| Pin | Name | Type | Description |
|-----|------------|---------|--|
| G5 | VSSD | GROUND | Digital ground |
| G6 | VSSR | GROUND | Radio ground |
| G7 | VSSR | GROUND | Radio ground |
| G8 | GANT | GROUND | Antenna shielding ground |
| G9 | VSSR | GROUND | Radio ground |
| H1 | NC | NC | Do not connect |
| H2 | P0.5 | GPIO | Port 0 Pin 5, analog/digital/lcd/csd |
| H3 | P0.1 | GPIO | Port 0 Pin 1, analog/digital/lcd/csd |
| H4 | XTAL24O | CLOCK | 24-MHz crystal |
| H5 | XTAL24I | CLOCK | 24-MHz crystal or external clock input |
| H6 | VSSR | GROUND | Radio ground |
| H7 | VSSR | GROUND | Radio ground |
| H8 | ANT | ANTENNA | Antenna pin |
| J1 | NC | NC | Do not connect |
| J2 | P0.4 | GPIO | Port 0 Pin 4, analog/digital/lcd/csd |
| J3 | P0.0 | GPIO | Port 0 Pin 0, analog/digital/lcd/csd |
| J4 | VDDR | POWER | 1.9-V to 5.5-V radio supply |
| J7 | VDDR | POWER | 1.9-V to 5.5-V radio supply |
| J8 | NO CONNECT | – | – |

High-speed I/O matrix (HSIOM) is a group of high-speed switches that routes GPIOs to the resources inside the device. These resources include CAPSENSE™, TCPWMs, I²C, SPI, UART, and LCD. HSIOM_PORT_SELx are 32-bit-wide registers that control the routing of GPIOs. Each register controls one port; four dedicated bits are assigned to each GPIO in the port. This provides up to 16 different options for GPIO routing as shown in [Table 4](#).

Table 4 HSIOM port settings

| Value | Description |
|-------|---|
| 0 | Firmware-controlled GPIO |
| 1 | Output is firmware-controlled, but Output Enable (OE) is controlled from DSI. |
| 2 | Both output and OE are controlled from DSI. |
| 3 | Output is controlled from DSI, but OE is firmware-controlled. |
| 4 | Pin is a CSD sense pin |
| 5 | Pin is a CSD shield pin |
| 6 | Pin is connected to AMUXA |
| 7 | Pin is connected to AMUXB |
| 8 | Pin-specific Active function #0 |
| 9 | Pin-specific Active function #1 |
| 10 | Pin-specific Active function #2 |
| 11 | Reserved |
| 12 | Pin is an LCD common pin |
| 13 | Pin is an LCD segment pin |

Table 4 **HSIOM port settings** *(continued)*

| Value | Description |
|--------------|-------------------------------------|
| 14 | Pin-specific Deep-Sleep function #0 |
| 15 | Pin-specific Deep-Sleep function #1 |

The selection of peripheral function for different GPIO pins is given in [Table 5](#).

Table 5 Port pin connections

| Name | Analog | Digital (HSIOM_PORT_SELx.SELy) ('x' denotes port number and 'y' denotes pin number) | | | | | | | |
|------|---------------|---|-------------|------------------|---------------------------|----------|--|--|--|
| | | 0 | 8 | 9 | 10 | Deep- | | | |
| | | GPIO | Active #0 | Active #1 | Active #2 | | | | |
| P0.0 | COMP0_INP | GPIO | TCPWM0_P[3] | SCB1_UART_RX[1] | | SCB1_I2C | | | |
| P0.1 | COMP0_INN | GPIO | TCPWM0_N[3] | SCB1_UART_TX[1] | | SCB1_I2C | | | |
| P0.2 | | GPIO | TCPWM1_P[3] | SCB1_UART_RTS[1] | | COMP0_C | | | |
| P0.3 | | GPIO | TCPWM1_N[3] | SCB1_UART_CTS[1] | | COMP1_C | | | |
| P0.4 | COMP1_INP | GPIO | TCPWM1_P[0] | SCB0_UART_RX[1] | EXT_CLK[0]/ ECO_OUT[0] | SCB0_I2C | | | |
| P0.5 | COMP1_INN | GPIO | TCPWM1_N[0] | SCB0_UART_TX[1] | | SCB0_I2C | | | |
| P0.6 | | GPIO | TCPWM2_P[0] | SCB0_UART_RTS[1] | | SWDIO[0] | | | |
| P0.7 | | GPIO | TCPWM2_N[0] | SCB0_UART_CTS[1] | | SWDCLK | | | |
| P1.0 | CTBm1_OA0_INP | GPIO | TCPWM0_P[1] | | | COMP0_C | | | |
| P1.1 | CTBm1_OA0_INN | GPIO | TCPWM0_N[1] | | | COMP1_C | | | |
| P1.2 | CTBm1_OA0_OUT | GPIO | TCPWM1_P[1] | | | | | | |
| P1.3 | CTBm1_OA1_OUT | GPIO | TCPWM1_N[1] | | | | | | |
| P1.4 | CTBm1_OA1_INN | GPIO | TCPWM2_P[1] | SCB0_UART_RX[0] | | SCB0_I2C | | | |
| P1.5 | CTBm1_OA1_INP | GPIO | TCPWM2_N[1] | SCB0_UART_TX[0] | | SCB0_I2C | | | |
| P1.6 | CTBm1_OA0_INP | GPIO | TCPWM3_P[1] | SCB0_UART_RTS[0] | | | | | |
| P1.7 | CTBm1_OA1_INP | GPIO | TCPWM3_N[1] | SCB0_UART_CTS[0] | | | | | |
| P2.0 | CTBm0_OA0_INP | GPIO | | | | | | | |
| P2.1 | CTBm0_OA0_INN | GPIO | | | | WAKEUP | | | |
| P2.2 | CTBm0_OA0_OUT | GPIO | | | | | | | |
| P2.3 | CTBm0_OA1_OUT | GPIO | | | | | | | |
| P2.4 | CTBm0_OA1_INN | GPIO | | | | | | | |
| P2.5 | CTBm0_OA1_INP | GPIO | | | | | | | |
| P2.6 | CTBm0_OA0_INP | GPIO | | | | | | | |
| P2.7 | CTBm0_OA1_INP | GPIO | | | EXT_CLK[1]/ECO_OUT[1] | | | | |
| P3.0 | SARMUX_0 | GPIO | TCPWM0_P[2] | SCB0_UART_RX[2] | | SCB0_I2C | | | |
| P3.1 | SARMUX_1 | GPIO | TCPWM0_N[2] | SCB0_UART_TX[2] | | SCB0_I2C | | | |
| P3.2 | SARMUX_2 | GPIO | TCPWM1_P[2] | SCB0_UART_RTS[2] | | | | | |

Table 5 Port pin connections (continued)

| Name | Analog | Digital (HSIOM_PORT_SELx.SELy) ('x' denotes port number and 'y' denotes pin number) | | | | | | | |
|--------------|----------|---|-------------|------------------|-----------------------|----------|--|--|--|
| | | 0 | 8 | 9 | 10 | Deep- | | | |
| | | GPIO | Active #0 | Active #1 | Active #2 | | | | |
| P3.3 | SARMUX_3 | GPIO | TCPWM1_N[2] | SCB0_UART_CTS[2] | | | | | |
| P3.4 | SARMUX_4 | GPIO | TCPWM2_P[2] | SCB1_UART_RX[2] | | SCB1_I2C | | | |
| P3.5 | SARMUX_5 | GPIO | TCPWM2_N[2] | SCB1_UART_TX[2] | | SCB1_I2C | | | |
| P3.6 | SARMUX_6 | GPIO | TCPWM3_P[2] | SCB1_UART_RTS[2] | | | | | |
| P3.7 | SARMUX_7 | GPIO | TCPWM3_N[2] | SCB1_UART_CTS[2] | | | | | |
| P4.0 | CMOD | GPIO | TCPWM0_P[0] | SCB1_UART_RTS[0] | | | | | |
| P4.1 | CTANK | GPIO | TCPWM0_N[0] | SCB1_UART_CTS[0] | | | | | |
| P5.0 | | GPIO | TCPWM3_P[0] | SCB1_UART_RX[0] | EXTPA_EN | SCB1_I2C | | | |
| P5.1 | | GPIO | TCPWM3_N[0] | SCB1_UART_TX[0] | EXT_CLK[2]/ECO_OUT[2] | SCB1_I2C | | | |
| P6.0_XTAL320 | | GPIO | | | | | | | |
| P6.1_XTAL321 | | GPIO | | | | | | | |

Pinouts

The possible pin connections are shown for all analog and digital peripherals (except the radio, LCD, and CSD blocks, which were shown in [Table 1](#)). A typical system application connection diagram is shown in [Figure 4](#).

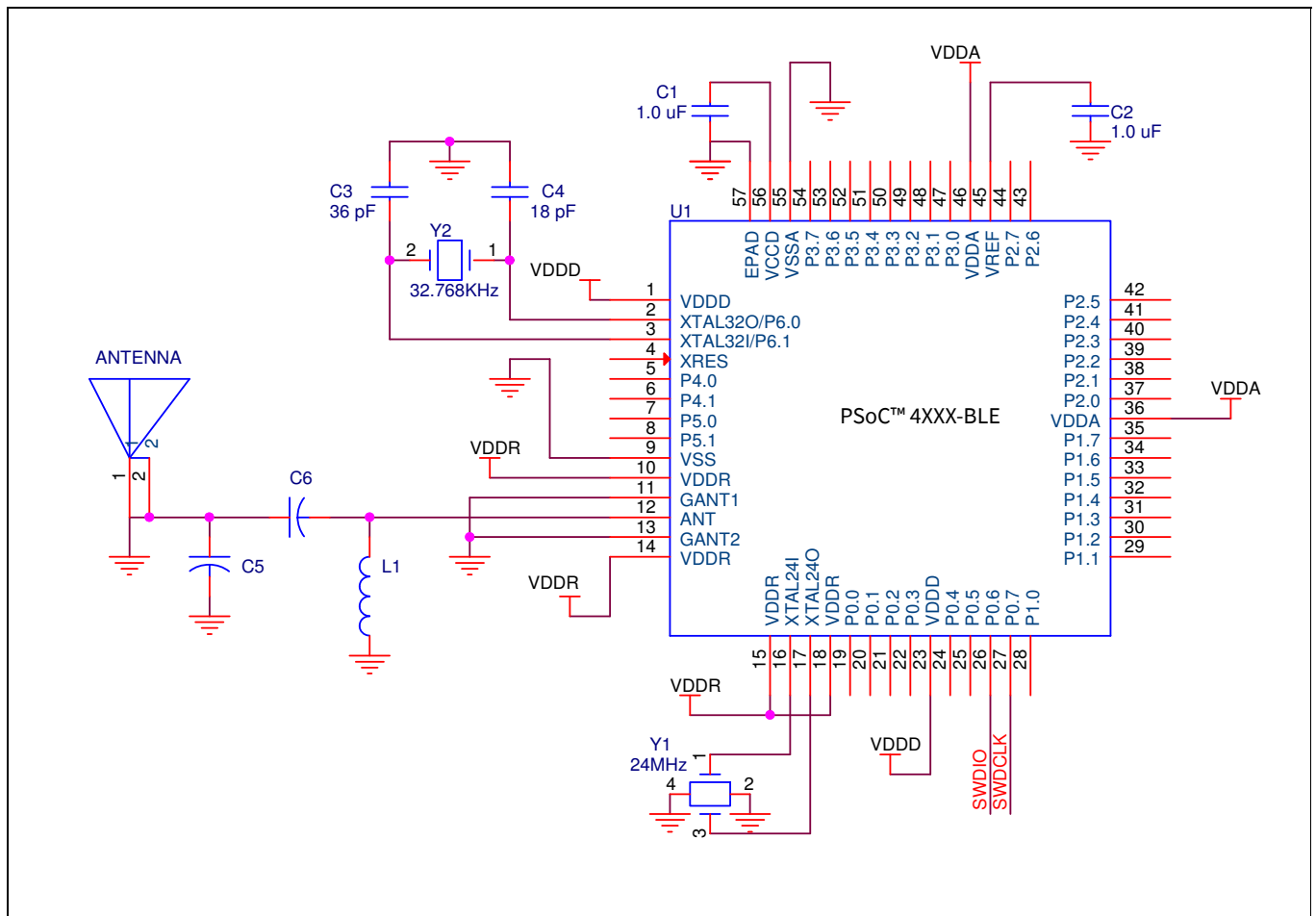

Figure 4 System application connection diagram

3 Power

The PSoC™ 4 CY8C41xx-BL MCU with AIROC™ Bluetooth® LE device can be supplied from batteries with a voltage range of 1.9 V to 5.5 V by directly connecting to the digital supply (VDDD), analog supply (VDDA), and radio supply (VDDR) pins. Internal LDOs in the device regulate the supply voltage to the required levels for different blocks. The device has one regulator for the digital circuitry and separate regulators for radio circuitry for noise isolation. Analog circuits run directly from the analog supply (VDDA) input. The device uses separate regulators for Deep-Sleep and Hibernate (lowered power supply and retention) modes to minimize the power consumption. The radio stops working below 1.9 V, but the device continues to function down to 1.71 V without RF. Note that VDDR must be supplied whenever VDDD is supplied.

Bypass capacitors must be used from VDDx (x = A, D, or R) to ground. The typical practice for systems in this frequency range is to use a capacitor in the 1- μ F range in parallel with a smaller capacitor (for example, 0.1 μ F). Note that these are simply rules of thumb and that, for critical applications, the PCB layout, lead inductance, and the bypass capacitor parasitic should be simulated to design and obtain optimal bypassing.

Table 6 Power supply

| Power supply | Bypass capacitors |
|---------------------|--|
| VDDD | 0.1- μ F ceramic at each pin plus bulk capacitor 1 μ F to 10 μ F. |
| VDDA | 0.1- μ F ceramic at each pin plus bulk capacitor 1 μ F to 10 μ F. |
| VDDR | 0.1- μ F ceramic at each pin plus bulk capacitor 1 μ F to 10 μ F. |
| VCCD | 1- μ F ceramic capacitor at the VCCD pin. |
| VREF (optional) | The internal bandgap may be bypassed with a 1- μ F to 10- μ F capacitor. |

4 Development support

The PSoC™ 4 CY8C41xx-BL MCU with AIROC™ Bluetooth® LE family has a rich set of documentation, development tools, and online resources to assist you during your development process. See [PSoC™ 4 MCU with AIROC™ Bluetooth® LE](#) to find out more.

4.1 Documentation

A suite of documentation supports the PSoC™ 4 CY8C41xx-BL MCU with AIROC™ Bluetooth® LE family to ensure that you can find answers to your questions quickly. This section contains a list of some of the key documents.

Software user guide: A step-by-step guide for using PSoC™ Creator. The software user guide shows you how the PSoC™ Creator build process works in detail, how to use source control with PSoC™ Creator, and much more.

Component datasheets: The flexibility of PSoC™ allows the creation of new peripherals (Components) long after the device has gone into production. Component datasheets provide all of the information needed to select and use a particular Component, including a functional description, API documentation, example code, and AC/DC specifications.

Application notes: PSoC™ application notes discuss a particular application of PSoC™ in depth; examples include creating standard and custom Bluetooth® LE profiles. Application notes often include example projects in addition to the application note document.

Technical reference manual (TRM): The TRM contains all the technical detail you need to use a PSoC™ device, including a complete description of all PSoC™ registers. The TRM is available in the Documentation section at [PSoC™ 4 MCU](#).

4.2 Online

In addition to print documentation, the PSoC™ forums connect you with fellow PSoC™ users and experts in PSoC™ from around the world, 24 hours a day, 7 days a week.

4.3 Tools

With industry standard cores, programming, and debugging interfaces, the PSoC™ 4 CY8C41xx-BL MCU with AIROC™ Bluetooth® LE family is part of a development tool ecosystem. See the [PSoC™ Creator](#) for the latest information on the revolutionary, easy to use PSoC™ Creator IDE, supported third party compilers, programmers, debuggers, and development kits.

5 Electrical specifications

5.1 Absolute maximum ratings

Table 7 Absolute maximum ratings^[1]

| Spec ID# | Parameter | Description | Min | Typ | Max | Unit | Details/ conditions |
|----------|-----------------------------------|---|---------------------|-----|-------------------------|------|--|
| SID1 | V _{DDD_ABS} | Analog, digital, or radio supply relative to V _{SS} (V _{SDD} = V _{SSA}) | -0.5 | - | 6 | V | Absolute max |
| SID2 | V _{CCD_ABS} | Direct digital core voltage input relative to V _{SDD} | -0.5 | - | 1.95 | V | Absolute max |
| SID3 | V _{GPIO_ABS} | GPIO voltage | -0.5 | - | V _{DD} +0.5 | V | Absolute max |
| SID4 | I _{GPIO_ABS} | Maximum current per GPIO | -25 | - | 25 | mA | Absolute max |
| SID5 | I _{GPIO_in- jection} | GPIO injection current, Max for V _{IH} > V _{DD} , and Min for V _{IL} < V _{SS} | -0.5 | - | 0.5 | mA | Absolute max, current injected per pin |
| BID57 | ESD_HBM | Electrostatic discharge human body model | 2200 ^[2] | - | - | V | |
| BID58 | ESD_CDM | Electrostatic discharge charged device model | 500 | - | - | V | |
| BID61 | LU | Pin current for latch-up | -200 | - | 200 | mA | |

Note

- Usage above the absolute maximum conditions listed in **Table 7** may cause permanent damage to the device. Exposure to absolute maximum conditions for extended periods of time may affect device reliability. The maximum storage temperature is 150°C in compliance with JEDEC Standard JESD22-A103, High Temperature Storage Life. When used below absolute maximum conditions but above normal operating conditions, the device may not operate to specification.
- This does not apply to the RF pins (ANT, XTALI, and XTALO). RF pins (ANT, XTALI, and XTALO) are tested for 500-V HBM.

5.2 Device level specifications

All specifications are valid for $-40^{\circ}\text{C} \leq \text{TA} \leq 105^{\circ}\text{C}$, except where noted. Specifications are valid for 1.71 V to 5.5 V, except where noted.

Table 8 DC specifications

| Spec ID# | Parameter | Description | Min | Typ | Max | Unit | Details/conditions |
|---|-------------------|--|------|------|------|---------------|--|
| SID6 | V_{DD} | Power supply input voltage ($V_{\text{DDA}} = V_{\text{DDD}} = V_{\text{DD}}$) | 1.8 | – | 5.5 | V | With regulator enabled |
| SID7 | V_{DD} | Power supply input voltage unregulated ($V_{\text{DDA}} = V_{\text{DDD}} = V_{\text{DD}}$) | 1.71 | 1.8 | 1.89 | V | Internally unregulated supply |
| SID8 | V_{DDR} | Radio supply voltage (Radio ON) | 1.9 | – | 5.5 | V | |
| SID8A | V_{DDR} | Radio supply voltage (Radio OFF) | 1.71 | – | 5.5 | V | |
| SID9 | V_{CCD} | Digital regulator output voltage (for core logic) | – | 1.8 | – | V | |
| SID10 | C_{VCCD} | Digital regulator output bypass capacitor | 1 | 1.3 | 1.6 | μF | X5R ceramic or better |
| Active mode, $V_{\text{DD}} = 1.71 \text{ V to } 5.5 \text{ V}$ | | | | | | | |
| SID13 | I_{DD3} | Execute from flash; CPU at 3 MHz | – | 1.7 | – | mA | $T = 25^{\circ}\text{C}$, $V_{\text{DD}} = 3.3 \text{ V}$ |
| SID14 | I_{DD4} | Execute from flash; CPU at 3 MHz | – | – | – | mA | $T = -40^{\circ}\text{C to } 105^{\circ}\text{C}$ |
| SID15 | I_{DD5} | Execute from flash; CPU at 6 MHz | – | 2.5 | – | mA | $T = 25^{\circ}\text{C}$, $V_{\text{DD}} = 3.3 \text{ V}$ |
| SID16 | I_{DD6} | Execute from flash; CPU at 6 MHz | – | – | – | mA | $T = -40^{\circ}\text{C to } 105^{\circ}\text{C}$ |
| SID17 | I_{DD7} | Execute from flash; CPU at 12 MHz | – | 4 | – | mA | $T = 25^{\circ}\text{C}$, $V_{\text{DD}} = 3.3 \text{ V}$ |
| SID18 | I_{DD8} | Execute from flash; CPU at 12 MHz | – | – | – | mA | $T = -40^{\circ}\text{C to } 105^{\circ}\text{C}$ |
| SID19 | I_{DD9} | Execute from flash; CPU at 24 MHz | – | 7.1 | – | mA | $T = 25^{\circ}\text{C}$, $V_{\text{DD}} = 3.3 \text{ V}$ |
| SID20 | I_{DD10} | Execute from flash; CPU at 24 MHz | – | – | – | mA | $T = -40^{\circ}\text{C to } 105^{\circ}\text{C}$ |
| SID21 | I_{DD11} | Execute from flash; CPU at 48 MHz | – | 13.4 | – | mA | $T = 25^{\circ}\text{C}$, $V_{\text{DD}} = 3.3 \text{ V}$ |
| SID22 | I_{DD12} | Execute from flash; CPU at 48 MHz | – | – | – | mA | $T = -40^{\circ}\text{C to } 105^{\circ}\text{C}$ |
| Sleep mode, $V_{\text{DD}} = 1.8 \text{ V to } 5.5 \text{ V}$ | | | | | | | |
| SID23 | I_{DD13} | IMO on | – | – | – | mA | $T = 25^{\circ}\text{C}$, $V_{\text{DD}} = 3.3 \text{ V}$, $\text{SYSCLK} = 3 \text{ MHz}$ |
| Sleep mode, V_{DD} and $V_{\text{DDR}} = 1.9 \text{ V to } 5.5 \text{ V}$ | | | | | | | |
| SID24 | I_{DD14} | ECO on | – | – | – | mA | $T = 25^{\circ}\text{C}$, $V_{\text{DD}} = 3.3 \text{ V}$, $\text{SYSCLK} = 3 \text{ MHz}$ |
| Deep-Sleep mode, $V_{\text{DD}} = 1.8 \text{ V to } 3.6 \text{ V}$ | | | | | | | |
| SID25 | I_{DD15} | WDT with WCO on | – | 1.3 | – | μA | $T = 25^{\circ}\text{C}$, $V_{\text{DD}} = 3.3 \text{ V}$ |
| SID26 | I_{DD16} | WDT with WCO on | – | – | – | μA | $T = -40^{\circ}\text{C to } 105^{\circ}\text{C}$ |

Electrical specifications

Table 8 DC specifications (continued)

| Spec ID# | Parameter | Description | Min | Typ | Max | Unit | Details/ conditions |
|--|-------------------|---------------------------------------|-----|-----|-----|------|---|
| Deep-Sleep mode, V_{DD} = 3.6 V to 5.5 V | | | | | | | |
| SID27 | I _{DD17} | WDT with WCO on | - | - | - | μA | T = 25°C, V _{DD} = 5 V |
| SID28 | I _{DD18} | WDT with WCO on | - | - | - | μA | T = -40°C to 105°C |
| Deep-Sleep mode, V_{DD} = 1.71 V to 1.89 V (Regulator Bypassed) | | | | | | | |
| SID29 | I _{DD19} | WDT with WCO on | - | - | - | μA | T = 25°C |
| SID30 | I _{DD20} | WDT with WCO on | - | - | - | μA | T = -40°C to 105°C |
| Deep-Sleep mode, V_{DD} = 2.5 V to 3.6 V | | | | | | | |
| SID31 | I _{DD21} | Opamp on | - | - | - | μA | T = 25°C, V _{DD} = 3.3 V |
| SID32 | I _{DD22} | Opamp on | - | - | - | μA | T = -40°C to 105°C |
| Deep-Sleep mode, V_{DD} = 3.6 V to 5.5 V | | | | | | | |
| SID33 | I _{DD23} | Opamp on | - | - | - | μA | T = 25°C, V _{DD} = 5 V |
| SID34 | I _{DD24} | Opamp on | - | - | - | μA | T = -40°C to 105°C |
| Hibernate mode, V_{DD} = 1.8 V to 3.6 V | | | | | | | |
| SID37 | I _{DD27} | GPIO and reset active | - | 150 | - | nA | T = 25°C, V _{DD} = 3.3 V |
| SID38 | I _{DD28} | GPIO and reset active | - | - | - | nA | T = -40°C to 105°C |
| Hibernate mode, V_{DD} = 3.6 V to 5.5 V | | | | | | | |
| SID39 | I _{DD29} | GPIO and reset active | - | - | - | nA | T = 25°C, V _{DD} = 5 V |
| SID40 | I _{DD30} | GPIO and reset active | - | - | - | nA | T = -40°C to 105°C |
| Hibernate mode, V_{DD} = 1.71 V to 1.89 V (Regulator Bypassed) | | | | | | | |
| SID41 | I _{DD31} | GPIO and reset active | - | - | - | nA | T = 25°C |
| SID42 | I _{DD32} | GPIO and reset active | - | - | - | nA | T = -40°C to 105°C |
| Stop mode, V_{DD} = 1.8 V to 3.6 V | | | | | | | |
| SID43 | I _{DD33} | Stop mode current (V _{DD}) | - | 20 | - | nA | T = 25°C, V _{DD} = 3.3 V |
| SID44 | I _{DD34} | Stop mode current (V _{DDR}) | - | 40 | -- | nA | T = 25°C, V _{DDR} = 3.3 V |
| SID45 | I _{DD35} | Stop mode current (V _{DD}) | - | - | - | nA | T = -40°C to 105°C |
| SID46 | I _{DD36} | Stop mode current (V _{DDR}) | - | - | - | nA | T = -40°C to 105°C, V _{DDR} = 1.9 V to 3.6 V |
| Stop mode, V_{DD} = 3.6 V to 5.5 V | | | | | | | |
| SID47 | I _{DD37} | Stop mode current (V _{DD}) | - | - | - | nA | T = 25°C, V _{DD} = 5 V |
| SID48 | I _{DD38} | Stop mode current (V _{DDR}) | - | - | - | nA | T = 25°C, V _{DDR} = 5 V |
| SID49 | I _{DD39} | Stop mode current (V _{DD}) | - | - | - | nA | T = -40°C to 105°C |
| SID50 | I _{DD40} | Stop mode current (V _{DDR}) | - | - | - | nA | T = -40°C to 105°C |

Electrical specifications

Table 8 DC specifications (continued)

| Spec ID# | Parameter | Description | Min | Typ | Max | Unit | Details/ conditions |
|--|------------|--------------------------------|-----|-----|-----|------|------------------------|
| Stop mode, $V_{DD} = 1.71\text{ V}$ to 1.89 V (Regulator Bypassed) | | | | | | | |
| SID51 | I_{DD41} | Stop mode current (V_{DD}) | – | – | – | nA | T = 25°C |
| SID52 | I_{DD42} | Stop mode current (V_{DD}) | – | – | – | nA | T = –40°C to 105°C |

Table 9 AC specifications

| Spec ID# | Parameter | Description | Min | Typ | Max | Unit | Details/ conditions |
|----------|-----------------|-----------------------------|-----|-----|-----|------|---|
| SID53 | F_{CPU} | CPU frequency | DC | – | 24 | MHz | $1.71\text{ V} \leq V_{DD} \leq 5.5\text{ V}$ |
| SID54 | T_{SLEEP} | Wakeup from Sleep mode | – | 0 | – | μs | Guaranteed by characterization |
| SID55 | $T_{DEEPSLEEP}$ | Wakeup from Deep-Sleep mode | – | – | 25 | μs | 24-MHz IMO. Guaranteed by characterization |
| SID56 | $T_{HIBERNATE}$ | Wakeup from Hibernate mode | – | – | 2 | ms | Guaranteed by characterization |
| SID57 | T_{STOP} | Wakeup from Stop mode | – | – | 2 | ms | Guaranteed by characterization |

Electrical specifications

5.2.1 GPIO

Table 10 GPIO DC specifications

| Spec ID# | Parameter | Description | Min | Typ | Max | Unit | Details/ conditions |
|----------|-----------------|---|----------------------|-----|---------------------|------------|---|
| SID58 | V_{IH} | Input voltage HIGH threshold | $0.7 \times V_{DD}$ | - | - | V | CMOS input |
| SID59 | V_{IL} | Input voltage LOW threshold | - | - | $0.3 \times V_{DD}$ | V | CMOS input |
| SID60 | V_{IH} | LVTTL input, $V_{DD} < 2.7$ V | $0.7 \times V_{DD}$ | - | - | V | |
| SID61 | V_{IL} | LVTTL input, $V_{DD} < 2.7$ V | - | - | $0.3 \times V_{DD}$ | V | |
| SID62 | V_{IH} | LVTTL input, $V_{DD} \geq 2.7$ V | 2.0 | - | - | V | |
| SID63 | V_{IL} | LVTTL input, $V_{DD} \geq 2.7$ V | - | - | 0.8 | V | |
| SID64 | V_{OH} | Output voltage HIGH level | $V_{DD} - 0.6$ | - | - | V | $I_{OH} = 4$ mA at $3.3 - V_{DD}$ |
| SID65 | V_{OH} | Output voltage HIGH level | $V_{DD} - 0.5$ | - | - | V | $I_{OH} = 1$ mA at $1.8 - V_{DD}$ |
| SID66 | V_{OL} | Output voltage LOW level | - | - | 0.6 | V | $I_{OL} = 8$ mA at $3.3 - V_{DD}$ |
| SID67 | V_{OL} | Output voltage LOW level | - | - | 0.6 | V | $I_{OL} = 4$ mA at $1.8 - V_{DD}$ |
| SID68 | V_{OL} | Output voltage LOW level | - | - | 0.4 | V | $I_{OL} = 3$ mA at $3.3 - V_{DD}$ |
| SID69 | R_{PULLUP} | Pull-up resistor | 3.5 | 5.6 | 8.5 | k Ω | |
| SID70 | $R_{PULLDOWN}$ | Pull-down resistor | 3.5 | 5.6 | 8.5 | k Ω | |
| SID71 | I_{IL} | Input leakage current (absolute value) | - | - | 2 | nA | 25°C, $V_{DD} = 3.3$ V |
| SID72 | I_{IL_CTBM} | Input leakage on CTBm input pins | - | - | 4 | nA | |
| SID73 | C_{IN} | Input capacitance | - | - | 7 | pF | |
| SID74 | V_{HYSTTL} | Input hysteresis LVTTL | 25 | 40 | | mV | $V_{DD} > 2.7$ V |
| SID75 | $V_{HYSCMOS}$ | Input hysteresis CMOS | $0.05 \times V_{DD}$ | - | - | mV | |
| SID76 | I_{DIODE} | Current through protection diode to V_{DD}/V_{SS} | - | - | 100 | μ A | Except for overvoltage-to lerant pins (P5.0 and P5.1) |
| SID77 | I_{TOT_GPIO} | Maximum total source or sink chip current | - | - | 200 | mA | |

Note

3. V_{IH} must not exceed $V_{DD} + 0.2$ V.

Electrical specifications

Table 11 GPIO AC specifications

| Spec ID# | Parameter | Description | Min | Typ | Max | Unit | Details/conditions |
|----------|----------------------|---|-----|-----|------|------|--|
| SID78 | T _{RISEF} | Rise time in Fast-Strong mode | 2 | – | 12 | ns | 3.3-V V _{DD} , C _{LOAD} = 25 pF |
| SID79 | T _{FALLF} | Fall time in Fast-Strong mode | 2 | – | 12 | ns | 3.3-V V _{DD} , C _{LOAD} = 25 pF |
| SID80 | T _{RISES} | Rise time in Slow-Strong mode | 10 | – | 60 | ns | 3.3-V V _{DD} , C _{LOAD} = 25 pF |
| SID81 | T _{FALLS} | Fall time in Slow-Strong mode | 10 | – | 60 | ns | 3.3-V V _{DD} , C _{LOAD} = 25 pF |
| SID82 | F _{GPIOUT1} | GPIO Fout; 3.3 V ≤ V _{DD} ≤ 5.5 V. Fast-Strong mode | – | – | 33 | MHz | 90/10%, 25-pF load, 60/40 duty cycle |
| SID83 | F _{GPIOUT2} | GPIO Fout; 1.7 V ≤ V _{DD} ≤ 3.3 V. Fast-Strong mode | – | – | 16.7 | MHz | 90/10%, 25-pF load, 60/40 duty cycle |
| SID84 | F _{GPIOUT3} | GPIO Fout; 3.3 V ≤ V _{DD} ≤ 5.5 V. Slow-Strong mode | – | – | 7 | MHz | 90/10%, 25-pF load, 60/40 duty cycle |
| SID85 | F _{GPIOUT4} | GPIO Fout; 1.7 V ≤ V _{DD} ≤ 3.3 V. Slow-Strong mode | – | – | 3.5 | MHz | 90/10%, 25-pF load, 60/40 duty cycle |
| SID86 | F _{GPIOIN} | GPIO input operating frequency; 1.71 V ≤ V _{DD} ≤ 5.5 V | – | – | 48 | MHz | 90/10% V _{IO} |

Table 12 OVT GPIO DC specifications (P5_0 and P5_1 only)

| Spec ID# | Parameter | Description | Min | Typ | Max | Unit | Details/conditions |
|----------|-----------------|--|-----|-----|-----|------|--|
| SID71A | I _{IL} | Input leakage current (absolute value), V _{IH} > V _{DD} | – | – | 10 | μA | 25°C, V _{DD} = 0 V, V _{IH} = 3.0 V |
| SID66A | V _{OL} | Output voltage LOW level | – | – | 0.4 | V | I _{OL} = 20 mA, V _{DD} > 2.9 V |

Table 13 OVT GPIO AC specifications (P5_0 and P5_1 only)

| Spec ID# | Parameter | Description | Min | Typ | Max | Unit | Details/conditions |
|----------|------------------------|---|-----|-----|-----|------|--|
| SID78A | T _{RISE_OVFS} | Output rise time in Fast-Strong mode | 1.5 | – | 12 | ns | 25-pF load, 10%–90%, V _{DD} = 3.3 V |
| SID79A | T _{FALL_OVFS} | Output fall time in Fast-Strong mode | 1.5 | – | 12 | ns | 25-pF load, 10%–90%, V _{DD} = 3.3 V |
| SID80A | T _{RISS} | Output rise time in Slow-Strong mode | 10 | – | 60 | ns | 25-pF load, 10%–90%, V _{DD} = 3.3 V |

Electrical specifications

Table 13 OVT GPIO AC specifications (P5_0 and P5_1 only) (continued)

| Spec ID# | Parameter | Description | Min | Typ | Max | Unit | Details/conditions |
|----------|---------------|--|-----|-----|-----|------|--|
| SID81A | T_{FALLSS} | Output fall time in Slow-Strong mode | 10 | – | 60 | ns | 25-pF load, 10%–90%, $V_{DD}=3.3\text{ V}$ |
| SID82A | $F_{GPIOUT1}$ | GPIO F_{OUT} ; $3.3\text{ V} \leq V_{DD} \leq 5.5\text{ V}$ Fast-Strong mode | – | – | 24 | MHz | 90/10%, 25-pF load, 60/40 duty cycle |
| SID83A | $F_{GPIOUT2}$ | GPIO F_{OUT} ; $1.71\text{ V} \leq V_{DD} \leq 3.3\text{ V}$ Fast-Strong mode | – | – | 16 | MHz | 90/10%, 25-pF load, 60/40 duty cycle |

5.2.2 XRES

Table 14 XRES DC specifications

| Spec ID# | Parameter | Description | Min | Typ | Max | Unit | Details/conditions |
|----------|---------------|--|----------------------|-----|----------------------|---------------|--------------------|
| SID87 | V_{IH} | Input voltage HIGH threshold | $0.7 \times V_{DDD}$ | – | – | V | CMOS input |
| SID88 | V_{IL} | Input voltage LOW threshold | – | – | $0.3 \times V_{DDD}$ | V | CMOS input |
| SID89 | R_{pullup} | Pull-up resistor | 3.5 | 5.6 | 8.5 | k Ω | |
| SID90 | C_{IN} | Input capacitance | – | 3 | – | pF | |
| SID91 | $V_{HYSXRES}$ | Input voltage hysteresis | – | 100 | – | mV | |
| SID92 | I_{DIODE} | Current through protection diode to V_{DDD}/V_{SS} | – | – | 100 | μA | |

Table 15 XRES AC specifications

| Spec ID# | Parameter | Description | Min | Typ | Max | Unit | Details/conditions |
|----------|------------------|-------------------|-----|-----|-----|---------------|--------------------|
| SID93 | $T_{RESETWIDTH}$ | Reset pulse width | 1 | – | – | μs | |

Electrical specifications

5.3 Analog peripherals

5.3.1 Opamp

Table 16 Opamp specifications

| Spec ID# | Parameter | Description | Min | Typ | Max | Unit | Details/ conditions |
|--|--------------------------|---|-------|------|------------------------|-------|---|
| I_{DD} (Opamp block current. V_{DD} = 1.8 V. No Load) | | | | | | | |
| SID94 | I _{DD_HI} | Power = high | – | 1000 | 1300 | μA | |
| SID95 | I _{DD_MED} | Power = medium | – | 500 | – | μA | |
| SID96 | I _{DD_LOW} | Power = low | – | 250 | 350 | μA | |
| GBW (Load = 20 pF, 0.1 mA. V_{DDA} = 2.7 V) | | | | | | | |
| SID97 | GBW_HI | Power = high | 6 | – | – | MHz | |
| SID98 | GBW_MED | Power = medium | 4 | – | – | MHz | |
| SID99 | GBW_LO | Power = low | – | 1 | – | MHz | |
| I_{OUT_MAX} (V_{DDA} ≥ 2.7 V, 500 mV from Rail) | | | | | | | |
| SID100 | I _{OUT_MAX_HI} | Power = high | 10 | – | – | mA | |
| SID101 | I _{OUT_MAX_MID} | Power = medium | 10 | – | – | mA | |
| SID102 | I _{OUT_MAX_LO} | Power = low | – | 5 | – | mA | |
| I_{OUT} (V_{DDA} = 1.71 V, 500 mV from Rail) | | | | | | | |
| SID103 | I _{OUT_MAX_HI} | Power = high | 4 | – | – | mA | |
| SID104 | I _{OUT_MAX_MID} | Power = medium | 4 | – | – | mA | |
| SID105 | I _{OUT_MAX_LO} | Power = low | – | 2 | – | mA | |
| SID106 | V _{IN} | Charge pump on, V _{DDA} ≥ 2.7 V | –0.05 | – | V _{DDA} – 0.2 | V | |
| SID107 | V _{CM} | Charge pump on, V _{DDA} ≥ 2.7 V | –0.05 | – | V _{DDA} – 0.2 | V | |
| V_{OUT} (V_{DDA} ≥ 2.7 V) | | | | | | | |
| SID108 | V _{OUT_1} | Power = high, I _{LOAD} =10 mA | 0.5 | – | V _{DDA} – 0.5 | V | |
| SID109 | V _{OUT_2} | Power = high, I _{LOAD} =1 mA | 0.2 | – | V _{DDA} – 0.2 | V | |
| SID110 | V _{OUT_3} | Power = medium, I _{LOAD} =1 mA | 0.2 | – | V _{DDA} – 0.2 | V | |
| SID111 | V _{OUT_4} | Power = low, I _{LOAD} =0.1 mA | 0.2 | – | V _{DDA} – 0.2 | V | |
| SID112 | V _{OS_TR} | Offset voltage, trimmed | 1 | ±0.5 | 1 | mV | High mode |
| SID113 | V _{OS_TR} | Offset voltage, trimmed | – | ±1 | – | mV | Medium mode |
| SID114 | V _{OS_TR} | Offset voltage, trimmed | – | ±2 | – | mV | Low mode |
| SID115 | V _{OS_DR_TR} | Offset voltage drift, trimmed | –10 | ±3 | 10 | μV/°C | High mode |
| SID116 | V _{OS_DR_TR} | Offset voltage drift, trimmed | – | ±10 | – | μV/°C | Medium mode |
| SID117 | V _{OS_DR_TR} | Offset voltage drift, trimmed | – | ±10 | – | μV/°C | Low mode |
| SID118 | CMRR | DC | 65 | 70 | – | dB | V _{DDD} = 3.6 V, High-power mode |
| SID119 | PSRR | At 1 kHz, 100-mV ripple | 70 | 85 | – | dB | V _{DDD} = 3.6 V |
| Noise | | | | | | | |
| SID120 | V _{N1} | Input referred, 1 Hz–1 GHz, power = high | – | 94 | – | μVrms | |

Electrical specifications

Table 16 Opamp specifications (continued)

| Spec ID# | Parameter | Description | Min | Typ | Max | Unit | Details/ conditions |
|--|-----------------------|---|-----|------|----------------------|---------|------------------------|
| SID121 | V _{N2} | Input referred, 1 kHz, power = high | – | 72 | – | nV/rtHz | |
| SID122 | V _{N3} | Input referred, 10 kHz, power = high | – | 28 | – | nV/rtHz | |
| SID123 | V _{N4} | Input referred, 100 kHz, power = high | – | 15 | – | nV/rtHz | |
| SID124 | C _{LOAD} | Stable up to maximum load. Performance specs at 50 pF | – | – | 125 | pF | |
| SID125 | Slew_rate | Cload = 50 pF, Power = High, V _{DDA} ≥ 2.7 V | 6 | – | – | V/μs | |
| SID126 | T _{op_wake} | From disable to enable, no external RC dominating | – | 300 | – | μs | |
| Comp_mode (Comparator mode; 50-mV Drive, T_{RISE} = T_{FALL} (Approx.)) | | | | | | | |
| SID127 | T _{PD1} | Response time; power = high | – | 150 | – | ns | |
| SID128 | T _{PD2} | Response time; power = medium | – | 400 | – | ns | |
| SID129 | T _{PD3} | Response time; power = low | – | 2000 | – | ns | |
| SID130 | V _{hyst_op} | Hysteresis | – | 10 | – | mV | |
| Deep-Sleep mode (Deep-Sleep mode operation is only guaranteed for V_{DDA} > 2.5 V) | | | | | | | |
| SID131 | GBW_DS | Gain bandwidth product | – | 50 | – | kHz | |
| SID132 | IDD_DS | Current | – | 15 | – | μA | |
| SID133 | V _{os_DS} | Offset voltage | – | 5 | – | mV | |
| SID134 | V _{os_dr_DS} | Offset voltage drift | – | 20 | – | μV/°C | |
| SID135 | V _{out_DS} | Output voltage | 0.2 | – | V _{DD} -0.2 | V | |
| SID136 | V _{cm_DS} | Common mode voltage | 0.2 | – | V _{DD} -1.8 | V | |

Table 17 Comparator DC specifications

| Spec ID# | Parameter | Description | Min | Typ | Max | Unit | Details/ conditions |
|----------|----------------------|---|-----|-----|------------------------|------|--|
| SID140 | V _{OFFSET1} | Input offset voltage, Factory trim | – | – | ±10 | mV | |
| SID141 | V _{OFFSET2} | Input offset voltage, Custom trim | – | – | ±6 | mV | |
| SID141A | V _{OFFSET3} | Input offset voltage, ultra-low-power mode | – | ±12 | – | mV | V _{DDD} ≥ 2.6 V for Temp < 0°C V _{DDD} ≥ 1.8 V for Temp ≥ 0°C |
| SID142 | V _{HYST} | Hysteresis when enabled | – | 10 | 35 | mV | |
| SID143 | V _{ICM1} | Input common mode voltage in normal mode | 0 | – | V _{DDD} - 0.1 | V | Modes 1 and 2 |
| SID144 | V _{ICM2} | Input common mode voltage in low-power mode | 0 | – | V _{DDD} | V | |

Table 17 **Comparator DC specifications** (continued)

| Spec ID# | Parameter | Description | Min | Typ | Max | Unit | Details/ conditions |
|----------|------------|---|-----|-----|------------------|------|---|
| SID145 | V_{ICM3} | Input common mode voltage in ultra low-power mode | 0 | – | $V_{DD3} - 1.15$ | V | $V_{DD3} \geq 2.6$ V for Temp < 0 °C $V_{DD3} \geq 1.8$ V for Temp ≥ 0 °C |
| SID146 | CMRR | Common mode rejection ratio | 50 | – | – | dB | $V_{DD3} \geq 2.7$ V |
| SID147 | CMRR | Common mode rejection ratio | 42 | – | – | dB | $V_{DD3} \leq 2.7$ V |
| SID148 | I_{CMP1} | Block current, normal mode | – | – | 400 | μA | |
| SID149 | I_{CMP2} | Block current, low-power mode | – | – | 100 | μA | |
| SID150 | I_{CMP3} | Block current in ultra-low-power mode | – | 6 | – | μA | $V_{DD3} \geq 2.6$ V for Temp < 0 °C $V_{DD3} \geq 1.8$ V for Temp ≥ 0 °C |
| SID151 | Z_{CMP} | DC input impedance of comparator | 35 | – | – | MΩ | |

Table 18 **Comparator AC specifications**

| Spec ID# | Parameter | Description | Min | Typ | Max | Unit | Details/ conditions |
|----------|-------------|--|-----|-----|-----|------|---|
| SID152 | T_{RESP1} | Response time, normal mode, 50-mV overdrive | – | 38 | – | ns | 50-mV overdrive |
| SID153 | T_{RESP2} | Response time, low-power mode, 50-mV overdrive | – | 70 | – | ns | 50-mV overdrive |
| SID154 | T_{RESP3} | Response time, ultra-low-power mode, 50-mV overdrive | – | 2.3 | – | μs | 200-mV overdrive $V_{DD3} \geq 2.6$ V for Temp < 0 °C $V_{DD3} \geq 1.8$ V for Temp ≥ 0 °C |

Electrical specifications

5.3.2 Temperature sensor

Table 19 Temperature sensor specifications

| Spec ID# | Parameter | Description | Min | Typ | Max | Unit | Details/ conditions |
|----------|----------------------|-----------------------------|-----|-----|-----|------|------------------------|
| SID155 | T _{SENSACC} | Temperature-sensor accuracy | -5 | ±1 | 5 | °C | -40 to +85°C |

5.3.3 SAR ADC

Table 20 SAR ADC DC specifications

| Spec ID# | Parameter | Description | Min | Typ | Max | Unit | Details/ conditions |
|----------|-----------|------------------------------------|-----------------|-----|------------------|------|---|
| SID156 | A_RES | Resolution | - | - | 12 | bits | |
| SID157 | A_CHNIS_S | Number of channels - single-ended | - | - | 8 | | 8 full-speed |
| SID158 | A-CHNKS_D | Number of channels - differential | - | - | 4 | | Diff inputs use neighboring I/O |
| SID159 | A-MONO | Monotonicity | - | - | - | | Yes |
| SID160 | A_GAINERR | Gain error | - | - | ±0.1 | % | With external reference |
| SID161 | A_OFFSET | Input offset voltage | - | - | 2 | mV | Measured with 1-V V _{REF} |
| SID162 | A_ISAR | Current consumption | - | - | 1 | mA | |
| SID163 | A_VINS | Input voltage range - single-ended | V _{SS} | - | V _{DDA} | V | |
| SID164 | A_VIND | Input voltage range - differential | V _{SS} | - | V _{DDA} | V | |
| SID165 | A_INRES | Input resistance | - | - | 2.2 | kΩ | |
| SID166 | A_INCAP | Input capacitance | - | - | 10 | pF | |
| SID312 | VREFSAR | Trimmed internal reference to SAR | -1 | - | 1 | % | Percentage of V _{bg} (1.024 V) |

Table 21 SAR ADC AC specifications

| Spec ID# | Parameter | Description | Min | Typ | Max | Unit | Details/ conditions |
|----------|------------|---|------|-----|----------|------|--|
| SID167 | A_PSRR | Power-supply rejection ratio | 70 | - | - | dB | Measured at 1-V reference |
| SID168 | A_CMRR | Common-mode rejection ratio | 66 | - | - | dB | |
| SID169 | A_SAMP | Sample rate | - | - | 806 | ksps | |
| SID313 | Fsarintref | SAR operating speed without external ref. bypass | - | - | 100 | ksps | 12-bit resolution |
| SID170 | A_SNR | Signal-to-noise ratio (SNR) | 65 | - | - | dB | F _{IN} = 10 kHz |
| SID171 | A_BW | Input bandwidth without aliasing | - | - | A_SAMP/2 | kHz | |
| SID172 | A_INL | Integral nonlinearity. V _{DD} = 1.71 V to 5.5 V, 1 Msps | -1.7 | - | 2 | LSB | V _{REF} = 1 V to V _{DD} |
| SID173 | A_INL | Integral nonlinearity. V _{DDD} = 1.71 V to 3.6 V, 1 Msps | -1.5 | - | 1.7 | LSB | V _{REF} = 1.71 V to V _{DD} |

Electrical specifications

Table 21 SAR ADC AC specifications (continued)

| Spec ID# | Parameter | Description | Min | Typ | Max | Unit | Details/ conditions |
|----------|-----------|--|------|-----|-----|------|---------------------------------------|
| SID174 | A_INL | Integral nonlinearity. $V_{DD} = 1.71\text{ V}$ to 5.5 V , 500 Ksps | -1.5 | - | 1.7 | LSB | $V_{REF} = 1\text{ V}$ to V_{DD} |
| SID175 | A_dnl | Differential nonlinearity. $V_{DD} = 1.71\text{ V}$ to 5.5 V , 1 Msps | -1 | - | 2.2 | LSB | $V_{REF} = 1\text{ V}$ to V_{DD} |
| SID176 | A_DNL | Differential nonlinearity. $V_{DD} = 1.71\text{ V}$ to 3.6 V , 1 Msps | -1 | - | 2 | LSB | $V_{REF} = 1.71\text{ V}$ to V_{DD} |
| SID177 | A_DNL | Differential nonlinearity. $V_{DD} = 1.71\text{ V}$ to 5.5 V , 500 Ksps | -1 | - | 2.2 | LSB | $V_{REF} = 1\text{ V}$ to V_{DD} |
| SID178 | A_THD | Total harmonic distortion | - | - | -65 | dB | $F_{IN} = 10\text{ kHz}$ |

5.3.4 CSD

Table 22 CSD block specifications

| Spec ID# | Parameter | Description | Min | Typ | Max | Unit | Details/ conditions |
|----------|------------------|--|------|-----|-----|---------------|--|
| SID179 | V_{CSD} | Voltage range of operation | 1.71 | - | 5.5 | V | |
| SID180 | IDAC1 | DNL for 8-bit resolution | -1 | - | 1 | LSB | |
| SID181 | IDAC1 | INL for 8-bit resolution | -3 | - | 3 | LSB | |
| SID182 | IDAC2 | DNL for 7-bit resolution | -1 | - | 1 | LSB | |
| SID183 | IDAC2 | INL for 7-bit resolution | -3 | - | 3 | LSB | |
| SID184 | SNR | Ratio of counts of finger to noise | 5 | - | - | Ratio | Capacitance range of 9 pF to 35 pF, 0.1-pF sensitivity. Radio is not operating during the scan |
| SID185 | I_{DAC1_CRT1} | Output current of IDAC1 (8 bits) in High range | - | 612 | - | μA | |
| SID186 | I_{DAC1_CRT2} | Output current of IDAC1 (8 bits) in Low range | - | 306 | - | μA | |
| SID187 | I_{DAC2_CRT1} | Output current of IDAC2 (7 bits) in High range | - | 305 | - | μA | |
| SID188 | I_{DAC2_CRT2} | Output current of IDAC2 (7 bits) in Low range | - | 153 | - | μA | |

5.4 Digital peripherals

5.4.1 Timer

Table 23 Timer DC specifications

| Spec ID | Parameter | Description | Min | Typ | Max | Unit | Details/conditions |
|---------|-------------------|-------------------------------------|-----|-----|-----|------|---------------------|
| SID189 | I _{TIM1} | Block current consumption at 3 MHz | - | - | 42 | µA | 16-bit timer, 85°C |
| SID189A | | | - | - | 46 | µA | 16-bit timer, 105°C |
| SID190 | I _{TIM2} | Block current consumption at 12 MHz | - | - | 130 | µA | 16-bit timer, 85°C |
| SID190A | | | - | - | 137 | µA | 16-bit timer, 105°C |
| SID191 | I _{TIM3} | Block current consumption at 48 MHz | - | - | 535 | µA | 16-bit timer, 85°C |
| SID191A | | | - | - | 560 | µA | 16-bit timer, 105°C |

Table 24 Timer AC specifications

| Spec ID | Parameter | Description | Min | Typ | Max | Unit | Details/conditions |
|---------|-------------------------|--------------------------------|----------------------|-----|-----|------|--------------------|
| SID192 | T _{TIMFREQ} | Operating frequency | F _{CLK} | - | 48 | MHz | |
| SID193 | T _{CAPWINT} | Capture pulse width (internal) | 2 × T _{CLK} | - | - | ns | |
| SID194 | T _{CAPWEXT} | Capture pulse width (external) | 2 × T _{CLK} | - | - | ns | |
| SID195 | T _{TIMRES} | Timer resolution | T _{CLK} | - | - | ns | |
| SID196 | T _{TENWIDINT} | Enable pulse width (internal) | 2 × T _{CLK} | - | - | ns | |
| SID197 | T _{TENWIDEXT} | Enable pulse width (external) | 2 × T _{CLK} | - | - | ns | |
| SID198 | T _{TIMRESWINT} | Reset pulse width (internal) | 2 × T _{CLK} | - | - | ns | |
| SID199 | T _{TIMRESEXT} | Reset pulse width (external) | 2 × T _{CLK} | - | - | ns | |

Electrical specifications

5.4.2 Counter

Table 25 Counter DC specifications

| Spec ID | Parameter | Description | Min | Typ | Max | Unit | Details/conditions |
|---------|-------------------|-------------------------------------|-----|-----|-----|------|---------------------|
| SID200 | I _{CTR1} | Block current consumption at 3 MHz | - | - | 42 | µA | 16-bit timer, 85°C |
| SID200A | | | - | - | 46 | µA | 16-bit timer, 105°C |
| SID201 | I _{CTR2} | Block current consumption at 12 MHz | - | - | 130 | µA | 16-bit timer, 85°C |
| SID201A | | | - | - | 137 | µA | 16-bit timer, 105°C |
| SID202 | I _{CTR3} | Block current consumption at 48 MHz | - | - | 535 | µA | 16-bit timer, 85°C |
| SID202A | | | - | - | 560 | µA | 16-bit timer, 105°C |

Table 26 Counter AC specifications

| Spec ID | Parameter | Description | Min | Typ | Max | Unit | Details/conditions |
|---------|--------------------------|--------------------------------|----------------------|-----|-----|------|--------------------|
| SID203 | T _{CTRFREQ} | Operating frequency | F _{CLK} | - | 48 | MHz | |
| SID204 | T _{CTRPWINT} | Capture pulse width (internal) | 2 × T _{CLK} | - | - | ns | |
| SID205 | T _{CTRPWEXT} | Capture pulse width (external) | 2 × T _{CLK} | - | - | ns | |
| SID206 | T _{CTRES} | Counter Resolution | T _{CLK} | - | - | ns | |
| SID207 | T _{CENWIDINT} | Enable pulse width (internal) | 2 × T _{CLK} | - | - | ns | |
| SID208 | T _{CENWIDEXT} | Enable pulse width (external) | 2 × T _{CLK} | - | - | ns | |
| SID209 | T _{CTRRE-SWINT} | Reset pulse width (internal) | 2 × T _{CLK} | - | - | ns | |
| SID210 | T _{CTRRE-SWEXT} | Reset pulse width (external) | 2 × T _{CLK} | - | - | ns | |

Electrical specifications

5.4.3 Pulse width modulation (PWM)

Table 27 PWM DC specifications

| Spec ID | Parameter | Description | Min | Typ | Max | Unit | Details/ conditions |
|---------|-------------------|-------------------------------------|-----|-----|-----|------|------------------------|
| SID211 | I _{PWM1} | Block current consumption at 3 MHz | – | – | 42 | µA | 16-bit timer, 85°C |
| SID211A | | | – | – | 46 | µA | 16-bit timer, 105°C |
| SID212 | I _{PWM2} | Block current consumption at 12 MHz | – | – | 130 | µA | 16-bit timer, 85°C |
| SID212A | | | – | – | 137 | µA | 16-bit timer, 105°C |
| SID213 | I _{PWM3} | Block current consumption at 48 MHz | – | – | 535 | µA | 16-bit timer, 85°C |
| SID213A | | | – | – | 560 | µA | 16-bit timer, 105°C |

Table 28 PWM AC specifications

| Spec ID | Parameter | Description | Min | Typ | Max | Unit | Details/ conditions |
|---------|--------------------------|-------------------------------|----------------------|-----|-----|------|------------------------|
| SID214 | T _{PWMFREQ} | Operating frequency | F _{CLK} | – | 48 | MHz | |
| SID215 | T _{PWMPWINT} | Pulse width (internal) | 2 × T _{CLK} | – | – | ns | |
| SID216 | T _{PWMEXT} | Pulse width (external) | 2 × T _{CLK} | – | – | ns | |
| SID217 | T _{PWMKILLINT} | Kill pulse width (internal) | 2 × T _{CLK} | – | – | ns | |
| SID218 | T _{PWMKILLEXT} | Kill pulse width (external) | 2 × T _{CLK} | – | – | ns | |
| SID219 | T _{PWMEINT} | Enable pulse width (internal) | 2 × T _{CLK} | – | – | ns | |
| SID220 | T _{PWMENEXT} | Enable pulse width (external) | 2 × T _{CLK} | – | – | ns | |
| SID221 | T _{PWMRESWINT} | Reset pulse width (internal) | 2 × T _{CLK} | – | – | ns | |
| SID222 | T _{PWMRE-SWEXT} | Reset pulse width (external) | 2 × T _{CLK} | – | – | ns | |

Electrical specifications

5.4.4 I²C

Table 29 Fixed I²C DC specifications

| Spec ID | Parameter | Description | Min | Typ | Max | Unit | Details/ conditions |
|---------|-------------------|---|-----|-----|-----|------|------------------------|
| SID223 | I _{I2C1} | Block current consumption at 100 kHz | – | – | 50 | μA | |
| SID224 | I _{I2C2} | Block current consumption at 400 kHz | – | – | 155 | μA | |
| SID225 | I _{I2C3} | Block current consumption at 1 Mbps | – | – | 390 | μA | |
| SID226 | I _{I2C4} | I ² C enabled in Deep-Sleep mode | – | – | 1.4 | μA | |

Table 30 Fixed I²C AC specifications

| Spec ID | Parameter | Description | Min | Typ | Max | Unit | Details/ conditions |
|---------|-------------------|-------------|-----|-----|-----|------|------------------------|
| SID227 | F _{I2C1} | Bit rate | – | – | 1 | Mbps | |

5.4.5 LCD direct drive

Table 31 LCD direct drive DC specifications

| Spec ID | Parameter | Description | Min | Typ | Max | Unit | Details/ conditions |
|---------|-----------------------|---|-----|------|------|------|---------------------------------------|
| SID228 | I _{LCDLOW} | Operating current in low-power mode | – | 17.5 | – | μA | 16 × 4 small segment display at 50 Hz |
| SID229 | C _{LDCAP} | LCD capacitance per segment/common driver | – | 500 | 5000 | pF | |
| SID230 | LCD _{OFFSET} | Long-term segment offset | – | 20 | – | mV | |
| SID231 | I _{LCDOP1} | LCD system operating current V _{BIAS} = 5 V | – | 2 | – | mA | 32 × 4 segments. 50 Hz at 25°C |
| SID232 | I _{LCDOP2} | LCD system operating current V _{BIAS} = 3.3 V | – | 2 | – | mA | 32 × 4 segments 50 Hz at 25°C |

Table 32 LCD direct drive AC specifications

| Spec ID | Parameter | Description | Min | Typ | Max | Unit | Details/ conditions |
|---------|------------------|----------------|-----|-----|-----|------|------------------------|
| SID233 | F _{LCD} | LCD frame rate | 10 | 50 | 150 | Hz | |

Table 33 Fixed UART DC specifications

| Spec ID | Parameter | Description | Min | Typ | Max | Unit | Details/ conditions |
|---------|--------------------|--|-----|-----|-----|------|------------------------|
| SID234 | I _{UART1} | Block current consumption at 100 kbps | – | – | 55 | μA | |
| SID235 | I _{UART2} | Block current consumption at 1000 kbps | – | – | 312 | μA | |

Electrical specifications

Table 34 Fixed UART AC specifications

| Spec ID | Parameter | Description | Min | Typ | Max | Unit | Details/conditions |
|---------|-------------------|-------------|-----|-----|-----|------|--------------------|
| SID236 | F _{UART} | Bit rate | - | - | 1 | Mbps | |

5.4.6 SPI specifications

Table 35 Fixed SPI DC specifications

| Spec ID | Parameter | Description | Min | Typ | Max | Unit | Details/conditions |
|---------|-------------------|-------------------------------------|-----|-----|-----|------|--------------------|
| SID237 | I _{SPI1} | Block current consumption at 1 Mbps | - | - | 360 | µA | |
| SID238 | I _{SPI2} | Block current consumption at 4 Mbps | - | - | 560 | µA | |
| SID239 | I _{SPI3} | Block current consumption at 8 Mbps | - | - | 600 | µA | |

Table 36 Fixed SPI AC specifications

| Spec ID | Parameter | Description | Min | Typ | Max | Unit | Details/conditions |
|---------|------------------|---|-----|-----|-----|------|--------------------|
| SID240 | F _{SPI} | SPI operating frequency (master; 6x oversampling) | - | - | 8 | MHz | |

Table 37 Fixed SPI Master mode AC specifications

| Spec ID | Parameter | Description | Min | Typ | Max | Unit | Details/conditions |
|---------|------------------|--|-----|-----|-----|------|----------------------------------|
| SID241 | T _{DMO} | MOSI valid after S _{clock} driving edge | - | - | 18 | ns | |
| SID242 | T _{DSI} | MISO valid before S _{clock} capturing edge. Full clock, late MISO sampling used | 20 | - | - | ns | Full clock, late MISO sampling |
| SID243 | T _{HMO} | Previous MOSI data hold time | 0 | - | - | ns | Referred to Slave capturing edge |

Table 38 Fixed SPI Slave mode AC specifications

| Spec ID | Parameter | Description | Min | Typ | Max | Unit | Details/conditions |
|---------|----------------------|---|-----|-----|---------------------------|------|-------------------------|
| SID244 | T _{DMI} | MOSI valid before S _{clock} capturing edge | 40 | - | - | ns | |
| SID245 | T _{DSO} | MISO valid after S _{clock} driving edge | - | - | 42 + 3 × T _{SCB} | ns | |
| SID246 | T _{DSO_ext} | MISO valid after S _{clock} driving edge in external clock mode | - | - | 50 | ns | V _{DD} < 3.0 V |
| SID247 | T _{HSO} | Previous MISO data hold time | 0 | - | - | ns | |
| SID248 | T _{SSELSCK} | SSEL valid to first SCK valid edge | 100 | - | - | ns | |

5.5 Memory

Table 39 Flash DC specifications

| Spec ID | Parameter | Description | Min | Typ | Max | Unit | Details/ conditions |
|---------|-------------------|------------------------------------|------|-----|-----|------|--------------------------|
| SID249 | V _{PE} | Erase and program voltage | 1.71 | – | 5.5 | V | |
| SID310 | T _{WS32} | Number of Wait states at 16–24 MHz | 1 | – | – | | CPU execution from flash |
| SID311 | T _{WS16} | Number of Wait states for 0–16 MHz | 0 | – | – | | CPU execution from flash |

Table 40 Flash AC specifications

| Spec ID | Parameter | Description | Min | Typ | Max | Unit | Details/ conditions |
|---------|--|--|-------|-----|-----|--------|--|
| SID250 | T _{ROWWRITE} ^[4] | Row (block) write time (erase and program) | – | – | 20 | ms | Row (block) = 128 bytes |
| SID251 | T _{ROWERASE} ^[4] | Row erase time | – | – | 13 | ms | Row (block) = 128 bytes for 128-KB flash devices Row (block) = 256 bytes for 256-KB flash devices |
| SID252 | T _{ROWPROGRAM} ^[4] | Row program time after erase | – | – | 7 | ms | |
| SID253 | T _{BULKERASE} ^[4] | Bulk erase time (128 KB) | – | – | 35 | ms | |
| SID254 | T _{DEVPROG} ^[4] | Total device program time | – | – | 25 | s | |
| SID255 | F _{END} | Flash endurance | 100 K | – | – | cycles | |
| SID256 | F _{RET} | Flash retention. T _A ≤ 55°C, 100 K P/E cycles | 20 | – | – | years | |
| SID257 | F _{RET2} | Flash retention. T _A ≤ 85°C, 10 K P/E cycles | 10 | – | – | years | |
| SID257A | F _{RET3} | Flash retention. T _A ≤ 105°C, 10 K P/E cycles | 3 | – | – | years | For T _A ≥ 85°C |

Note

4. It can take as much as 20 milliseconds to write to flash. During this time, the device should not be reset, or flash operations will be interrupted and cannot be relied on to have completed. Reset sources include the XRES pin, software resets, CPU lockup states and privilege violations, improper power supply levels, and watchdogs. Make certain that these are not inadvertently activated.

Electrical specifications

5.6 System resources

5.6.1 Power-on reset (POR)

Table 41 POR DC specifications

| Spec ID | Parameter | Description | Min | Typ | Max | Unit | Details/conditions |
|---------|-----------------------|----------------------|------|-----|------|------|--------------------|
| SID258 | V _{RISEIPOR} | Rising trip voltage | 0.80 | – | 1.45 | V | |
| SID259 | V _{FALLIPOR} | Falling trip voltage | 0.75 | – | 1.40 | V | |
| SID260 | V _{IPOHYST} | Hysteresis | 15 | – | 200 | mV | |

Table 42 POR AC specifications

| Spec ID | Parameter | Description | Min | Typ | Max | Unit | Details/conditions |
|---------|----------------------|--|-----|-----|-----|------|--------------------|
| SID264 | T _{PPOR_TR} | PPOR response time in Active and Sleep modes | – | – | 1 | µs | |

Table 43 Brown-out detect

| Spec ID# | Parameter | Description | Min | Typ | Max | Unit | Details/conditions |
|----------|------------------------|--|------|-----|-----|------|--------------------|
| SID261 | V _{FALLPPOR} | BOD trip voltage in Active and Sleep modes | 1.64 | – | – | V | |
| SID262 | V _{FALLDPSLP} | BOD trip voltage in Deep-Sleep mode | 1.4 | – | – | V | |

Table 44 Hibernate reset

| Spec ID# | Parameter | Description | Min | Typ | Max | Unit | Details/conditions |
|----------|----------------------|------------------------------------|-----|-----|-----|------|--------------------|
| SID263 | V _{HBRTRIP} | BOD trip voltage in Hibernate mode | 1.1 | – | – | V | |

5.6.2 Voltage monitors

Table 45 Voltage monitor DC specifications

| Spec ID | Parameter | Description | Min | Typ | Max | Unit | Details/conditions |
|---------|--------------------|--------------------------|------|------|------|------|--------------------|
| SID265 | V _{LVI1} | LVI_A/D_SEL[3:0] = 0000b | 1.71 | 1.75 | 1.79 | V | |
| SID266 | V _{LVI2} | LVI_A/D_SEL[3:0] = 0001b | 1.76 | 1.80 | 1.85 | V | |
| SID267 | V _{LVI3} | LVI_A/D_SEL[3:0] = 0010b | 1.85 | 1.90 | 1.95 | V | |
| SID268 | V _{LVI4} | LVI_A/D_SEL[3:0] = 0011b | 1.95 | 2.00 | 2.05 | V | |
| SID269 | V _{LVI5} | LVI_A/D_SEL[3:0] = 0100b | 2.05 | 2.10 | 2.15 | V | |
| SID270 | V _{LVI6} | LVI_A/D_SEL[3:0] = 0101b | 2.15 | 2.20 | 2.26 | V | |
| SID271 | V _{LVI7} | LVI_A/D_SEL[3:0] = 0110b | 2.24 | 2.30 | 2.36 | V | |
| SID272 | V _{LVI8} | LVI_A/D_SEL[3:0] = 0111b | 2.34 | 2.40 | 2.46 | V | |
| SID273 | V _{LVI9} | LVI_A/D_SEL[3:0] = 1000b | 2.44 | 2.50 | 2.56 | V | |
| SID274 | V _{LVI10} | LVI_A/D_SEL[3:0] = 1001b | 2.54 | 2.60 | 2.67 | V | |
| SID275 | V _{LVI11} | LVI_A/D_SEL[3:0] = 1010b | 2.63 | 2.70 | 2.77 | V | |
| SID276 | V _{LVI12} | LVI_A/D_SEL[3:0] = 1011b | 2.73 | 2.80 | 2.87 | V | |
| SID277 | V _{LVI13} | LVI_A/D_SEL[3:0] = 1100b | 2.83 | 2.90 | 2.97 | V | |
| SID278 | V _{LVI14} | LVI_A/D_SEL[3:0] = 1101b | 2.93 | 3.00 | 3.08 | V | |

Electrical specifications

Table 45 Voltage monitor DC specifications (continued)

| Spec ID | Parameter | Description | Min | Typ | Max | Unit | Details/conditions |
|---------|--------------------|--------------------------|------|------|------|------|--------------------|
| SID279 | V _{LVI15} | LVI_A/D_SEL[3:0] = 1110b | 3.12 | 3.20 | 3.28 | V | |
| SID280 | V _{LVI16} | LVI_A/D_SEL[3:0] = 1111b | 4.39 | 4.50 | 4.61 | V | |
| SID281 | LVI_IDD | Block current | - | - | 100 | µA | |

Table 46 Voltage monitor AC specifications

| Spec ID | Parameter | Description | Min | Typ | Max | Unit | Details/conditions |
|---------|----------------------|---------------------------|-----|-----|-----|------|--------------------|
| SID282 | T _{MONTRIP} | Voltage monitor trip time | - | - | 1 | µs | |

5.6.3 SWD interface

Table 47 SWD interface specifications

| Spec ID | Parameter | Description | Min | Typ | Max | Unit | Details/conditions |
|---------|--------------|---|----------|-----|---------|------|----------------------------------|
| SID283 | F_SWDCCLK1 | $3.3\text{ V} \leq V_{DD} \leq 5.5\text{ V}$ | - | - | 14 | MHz | SWDCLK ≤ 1/3 CPU clock frequency |
| SID284 | F_SWDCCLK2 | $1.71\text{ V} \leq V_{DD} \leq 3.3\text{ V}$ | - | - | 7 | MHz | SWDCLK ≤ 1/3 CPU clock frequency |
| SID285 | T_SWDI_SETUP | T = 1/f SWDCLK | 0.25 × T | - | - | ns | |
| SID286 | T_SWDI_HOLD | T = 1/f SWDCLK | 0.25 × T | - | - | ns | |
| SID287 | T_SWDO_VALID | T = 1/f SWDCLK | - | - | 0.5 × T | ns | |
| SID288 | T_SWDO_HOLD | T = 1/f SWDCLK | 1 | - | - | ns | |

5.6.4 Internal main oscillator

Table 48 IMO DC specifications

| Spec ID | Parameter | Description | Min | Typ | Max | Unit | Details/conditions |
|---------|-------------------|---------------------------------|-----|-----|------|------|--------------------|
| SID289 | I _{IMO1} | IMO operating current at 48 MHz | - | - | 1000 | µA | |
| SID290 | I _{IMO2} | IMO operating current at 24 MHz | - | - | 325 | µA | |
| SID291 | I _{IMO3} | IMO operating current at 12 MHz | - | - | 225 | µA | |
| SID292 | I _{IMO4} | IMO operating current at 6 MHz | - | - | 180 | µA | |
| SID293 | I _{IMO5} | IMO operating current at 3 MHz | - | - | 150 | µA | |

Table 49 IMO AC specifications

| Spec ID | Parameter | Description | Min | Typ | Max | Unit | Details/conditions |
|---------|----------------------|--------------------------------------|-----|-----|-----|------|-----------------------------|
| SID296 | F _{IMOTOL3} | Frequency variation from 3 to 48 MHz | - | - | ±2 | % | With API-called calibration |
| SID297 | F _{IMOTOL3} | IMO startup time | - | - | 12 | µs | |

Electrical specifications

5.6.5 Internal low-speed oscillator

Table 50 ILO DC specifications

| Spec ID | Parameter | Description | Min | Typ | Max | Unit | Details/conditions |
|---------|-------------------|---------------------------------|-----|-----|------|------|----------------------|
| SID298 | I _{ILO2} | ILO operating current at 32 kHz | – | 0.3 | 1.05 | μA | Guaranteed by design |

Table 51 ILO AC specifications

| Spec ID | Parameter | Description | Min | Typ | Max | Unit | Details/conditions |
|---------|------------------------|--------------------------|-----|-----|-----|------|--------------------|
| SID299 | T _{STARTILO1} | ILO startup time | – | – | 2 | ms | |
| SID300 | F _{ILOTRIM1} | 32-kHz trimmed frequency | 15 | 32 | 50 | kHz | |

Table 52 External clock specifications

| Spec ID | Parameter | Description | Min | Typ | Max | Unit | Details/conditions |
|---------|------------|--|-----|-----|-----|------|-----------------------|
| SID301 | ExtClkFreq | External clock input frequency | 0 | – | 48 | MHz | CMOS input level only |
| SID302 | ExtClkDuty | Duty cycle; Measured at V _{DD} /2 | 45 | – | 55 | % | CMOS input level only |

Table 53 UDB AC specifications

| Spec ID | Parameter | Description | Min | Typ | Max | Unit | Details/conditions |
|------------------------------------|---------------------------|--|-----|-----|-----|------|--------------------|
| Data path performance | | | | | | | |
| SID303 | F _{MAX-TIMER} | Max frequency of 16-bit timer in a UDB pair | – | – | 48 | MHz | |
| SID304 | F _{MAX-ADDER} | Max frequency of 16-bit adder in a UDB pair | – | – | 48 | MHz | |
| SID305 | F _{MAX_CRC} | Max frequency of 16-bit CRC/PRS in a UDB pair | – | – | 48 | MHz | |
| PLD performance in UDB | | | | | | | |
| SID306 | F _{MAX_PLD} | Max frequency of 2-pass PLD function in a UDB pair | – | – | 48 | MHz | |
| Clock to output performance | | | | | | | |
| SID307 | T _{CLK_OUT_UBD1} | Prop. delay for clock in to data out at 25 °C, Typical | – | 15 | – | ns | |
| SID308 | T _{CLK_OUT_UBD2} | Prop. delay for clock in to data out, Worst case | – | 25 | – | ns | |

Electrical specifications

Table 54 Bluetooth® LE subsystem

| Spec ID# | Parameter | Description | Min | Typ | Max | Unit | Details/conditions |
|----------------------------------|---------------|--|-----|-----|-----|------|---------------------------------------|
| RF receiver specification | | | | | | | |
| SID340 | RXS, IDLE | RX sensitivity with idle transmitter | - | -89 | - | dBm | |
| SID340A | | RX sensitivity with idle transmitter excluding Balun loss | - | -91 | - | dBm | Guaranteed by design simulation |
| SID341 | RXS, DIRTY | RX sensitivity with dirty transmitter | - | -87 | -70 | dBm | RF-PHY Specification (RCV-LE/CA/01/C) |
| SID342 | RXS, HIGHGAIN | RX sensitivity in high-gain mode with idle transmitter | - | -91 | - | dBm | |
| SID343 | PRXMAX | Maximum input power | -10 | -1 | - | dBm | RF-PHY Specification (RCV-LE/CA/06/C) |
| SID344 | CI1 | Cochannel interference, Wanted signal at -67 dBm and Interferer at FRX | - | 9 | 21 | dB | RF-PHY Specification (RCV-LE/CA/03/C) |
| SID345 | CI2 | Adjacent channel interference Wanted signal at -67 dBm and Interferer at FRX ±1 MHz | - | 3 | 15 | dB | RF-PHY Specification (RCV-LE/CA/03/C) |
| SID346 | CI3 | Adjacent channel interference Wanted signal at -67 dBm and Interferer at FRX ±2 MHz | - | -29 | - | dB | RF-PHY Specification (RCV-LE/CA/03/C) |
| SID347 | CI4 | Adjacent channel interference Wanted signal at -67 dBm and Interferer at ≥FRX ±3 MHz | - | -39 | - | dB | RF-PHY Specification (RCV-LE/CA/03/C) |
| SID348 | CI5 | Adjacent channel interference Wanted Signal at -67 dBm and Interferer at Image frequency (F _{IMAGE}) | - | -20 | - | dB | RF-PHY Specification (RCV-LE/CA/03/C) |
| SID349 | CI3 | Adjacent channel interference Wanted signal at -67 dBm and Interferer at Image frequency (F _{IMAGE} ± 1 MHz) | - | -30 | - | dB | RF-PHY Specification (RCV-LE/CA/03/C) |
| SID350 | OBB1 | Out-of-band blocking, Wanted signal at -67 dBm and Interferer at F = 30–2000 MHz | -30 | -27 | - | dBm | RF-PHY Specification (RCV-LE/CA/04/C) |
| SID351 | OBB2 | Out-of-band blocking, Wanted signal at -67 dBm and Interferer at F = 2003–2399 MHz | -35 | -27 | - | dBm | RF-PHY Specification (RCV-LE/CA/04/C) |
| SID352 | OBB3 | Out-of-band blocking, Wanted signal at -67 dBm and Interferer at F = 2484–2997 MHz | -35 | -27 | - | dBm | RF-PHY Specification (RCV-LE/CA/04/C) |

Electrical specifications

Table 54 Bluetooth® LE subsystem (continued)

| Spec ID# | Parameter | Description | Min | Typ | Max | Unit | Details/conditions |
|----------|-----------|---|-----|-----|-----|------|--|
| SID353 | OBB4 | Out-of-band blocking, Wanted signal a -67 dBm and Interferer at F = 3000-12750 MHz | -30 | -27 | - | dBm | RF-PHY Specification (RCV-LE/CA/04/C) |
| SID354 | IMD | Intermodulation performance Wanted signal at -64 dBm and 1-Mbps Bluetooth® LE, third, fourth, and fifth offset channel | -50 | - | - | dBm | RF-PHY Specification (RCV-LE/CA/05/C) |
| SID355 | RXSE1 | Receiver spurious emission 30 MHz to 1.0 GHz | - | - | -57 | dBm | 100-kHz measurement bandwidth ETSI EN300 328 V1.8.1 |
| SID356 | RXSE2 | Receiver spurious emission 1.0 GHz to 12.75 GHz | - | - | -47 | dBm | 1-MHz measurement bandwidth ETSI EN300 328 V1.8.1 |

RF transmitter specifications

| | | | | | | | |
|--------|-------------|--|------|-----|-------|--------------------|---------------------------------------|
| SID357 | TXP, ACC | RF power accuracy | - | ±1 | - | dB | |
| SID358 | TXP, RANGE | RF power control range | - | 20 | - | dB | |
| SID359 | TXP, 0dBm | Output power, 0-dB Gain setting (PA7) | - | 0 | - | dBm | |
| SID360 | TXP, MAX | Output power, maximum power setting (PA10) | - | 3 | - | dBm | |
| SID361 | TXP, MIN | Output power, minimum power setting (PA1) | - | -18 | - | dBm | |
| SID362 | F2AVG | Average frequency deviation for 10101010 pattern | 185 | - | - | kHz | RF-PHY Specification (TRM-LE/CA/05/C) |
| SID363 | F1AVG | Average frequency deviation for 11110000 pattern | 225 | 250 | 275 | kHz | RF-PHY Specification (TRM-LE/CA/05/C) |
| SID364 | EO | Eye opening = $\Delta F_{2AVG} / \Delta F_{1AVG}$ | 0.8 | - | - | | RF-PHY Specification (TRM-LE/CA/05/C) |
| SID365 | FTX, ACC | Frequency accuracy | -150 | - | 150 | kHz | RF-PHY Specification (TRM-LE/CA/06/C) |
| SID366 | FTX, MAXDR | Maximum frequency drift | -50 | - | 50 | kHz | RF-PHY Specification (TRM-LE/CA/06/C) |
| SID367 | FTX, INITDR | Initial frequency drift | -20 | - | 20 | kHz | RF-PHY Specification (TRM-LE/CA/06/C) |
| SID368 | FTX, DR | Maximum drift rate | -20 | - | 20 | kHz/ 50 μ s | RF-PHY Specification (TRM-LE/CA/06/C) |
| SID369 | IBSE1 | In-band spurious emission at 2-MHz offset | - | - | -20 | dBm | RF-PHY Specification (TRM-LE/CA/03/C) |
| SID370 | IBSE2 | In-band spurious emission at \geq 3-MHz offset | - | - | -30 | dBm | RF-PHY Specification (TRM-LE/CA/03/C) |
| SID371 | TXSE1 | Transmitter spurious emissions (average), <1.0 GHz | - | - | -55.5 | dBm | FCC-15.247 |

Electrical specifications

Table 54 Bluetooth® LE subsystem (continued)

| Spec ID# | Parameter | Description | Min | Typ | Max | Unit | Details/conditions |
|----------------------------------|-----------------|---|------|------|-------|------|--|
| SID372 | TXSE2 | Transmitter spurious emissions (average), >1.0 GHz | - | - | -41.5 | dBm | FCC-15.247 |
| RF current specifications | | | | | | | |
| SID373 | IRX | Receive current in normal mode | - | 18.7 | - | mA | |
| SID373A | IRX_RF | Radio receive current in normal mode | - | 16.4 | - | mA | Measured at V _{DDR} |
| SID374 | IRX, HIGHGAIN | Receive current in high-gain mode | - | 21.5 | - | mA | |
| SID375 | ITX, 3dBm | TX current at 3-dBm setting (PA10) | - | 20 | - | mA | |
| SID376 | ITX, 0dBm | TX current at 0-dBm setting (PA7) | - | 16.5 | - | mA | |
| SID376A | ITX_RF, 0dBm | Radio TX current at 0 dBm setting (PA7) | - | 15.6 | - | mA | Measured at V _{DDR} |
| SID376B | ITX_RF, 0dBm | Radio TX current at 0 dBm excluding Balun loss | - | 14.2 | - | mA | Guaranteed by design simulation |
| SID377 | ITX,-3dBm | TX current at -3-dBm setting (PA4) | - | 15.5 | - | mA | |
| SID378 | ITX,-6dBm | TX current at -6-dBm setting (PA3) | - | 14.5 | - | mA | |
| SID379 | ITX,-12dBm | TX current at -12-dBm setting (PA2) | - | 13.2 | - | mA | |
| SID380 | ITX,-18dBm | TX current at -18-dBm setting (PA1) | - | 12.5 | - | mA | |
| SID380A | Iavg_1sec, 0dBm | Average current at 1-second Bluetooth® LE connection interval | - | 17.1 | - | µA | TXP: 0 dBm; ±20-ppm master and slave clock accuracy. |
| SID380B | Iavg_4sec, 0dBm | Average current at 4-second Bluetooth® LE connection interval | - | 6.1 | - | µA | TXP: 0 dBm; ±20-ppm master and slave clock accuracy. |
| General RF specifications | | | | | | | |
| SID381 | FREQ | RF operating frequency | 2400 | - | 2482 | MHz | |
| SID382 | CHBW | Channel spacing | - | 2 | - | MHz | |
| SID383 | DR | On-air data rate | - | 1000 | - | kbps | |
| SID384 | IDLE2TX | Bluetooth® LE.IDLE to Bluetooth® LE. TX transition time | - | 120 | 140 | µs | |
| SID385 | IDLE2RX | Bluetooth® LE.IDLE to Bluetooth® LE. RX transition time | - | 75 | 120 | µs | |
| RSSI specifications | | | | | | | |
| SID386 | RSSI, ACC | RSSI accuracy | - | ±5 | - | dB | |
| SID387 | RSSI, RES | RSSI resolution | - | 1 | - | dB | |
| SID388 | RSSI, PER | RSSI sample period | - | 6 | - | µs | |

Electrical specifications

Table 55 ECO specifications

| Spec ID# | Parameter | Description | Min | Typ | Max | Unit | Details/conditions |
|----------|---------------------|--------------------------------|-----|------|-----|------|-------------------------|
| SID389 | F _{ECO} | Crystal frequency | – | 24 | – | MHz | |
| SID390 | F _{TOL} | Frequency tolerance | –50 | – | 50 | ppm | |
| SID391 | ESR | Equivalent series resistance | – | – | 60 | Ω | |
| SID392 | PD | Drive level | – | – | 100 | μW | |
| SID393 | T _{START1} | Startup time (Fast Charge on) | – | – | 850 | μs | |
| SID394 | T _{START2} | Startup time (Fast Charge off) | – | – | 3 | ms | |
| SID395 | C _L | Load capacitance | – | 8 | – | pF | |
| SID396 | C ₀ | Shunt capacitance | – | 1.1 | – | pF | |
| SID397 | I _{ECO} | Operating current | – | 1400 | – | μA | Includes LDO+BG current |

Table 56 WCO specifications

| Spec ID# | Parameter | Description | Min | Typ | Max | Unit | Details/conditions |
|----------|--------------------|-------------------------------------|-----|--------|------|------|--------------------|
| SID398 | F _{WCO} | Crystal frequency | – | 32.768 | – | kHz | |
| SID399 | FTOL | Frequency tolerance | – | 50 | – | ppm | |
| SID400 | ESR | Equivalent series resistance | – | 50 | – | kΩ | |
| SID401 | PD | Drive level | – | – | 1 | μW | |
| SID402 | T _{START} | Startup time | – | – | 500 | ms | |
| SID403 | C _L | Crystal load capacitance | 6 | – | 12.5 | pF | |
| SID404 | C ₀ | Crystal shunt capacitance | – | 1.35 | – | pF | |
| SID405 | I _{WCO1} | Operating current (High-Power mode) | – | – | 8 | μA | |
| SID406 | I _{WCO2} | Operating current (low-power mode) | – | – | 1 | μA | 85°C |
| SID406A | | | – | – | 2.6 | μA | 105°C |

6 Ordering information

The PSoC™ 4 CY8C41xx-BL MCU with AIROC™ Bluetooth® LE part numbers and features are listed in the following table.

Table 57 PSoC™ 4 CY8C41xx-BL MCU with AIROC™ Bluetooth® LE part numbers

| Product family | MPN | Max CPU Speed (MHz) | Bluetooth® LE subsystem | Flash (KB) | SRAM (KB) | UDB | Opamp | CAPSENSE™ | TMG (Gestures) | Direct LCD drive | 12-bit SAR ADC | DMA | LP comparators | TCPWM blocks | SCB blocks | GPIO | Package | Temperature range |
|---|-------------------|---------------------|-------------------------|------------|-----------|-----|-------|-----------|----------------|------------------|----------------|-----|----------------|--------------|------------|------|---------|-------------------|
| PSoC™ 4 CY8C41xx-BL MCU with AIROC™ Bluetooth® LE | CY8C4127LQI-BL473 | 24 | 4.1 | 128 | 16 | - | 2 | - | - | - | 806 ksps | - | 2 | 4 | 2 | 36 | QFN | 85°C |
| | CY8C4127LQI-BL453 | 24 | 4.1 | 128 | 16 | - | 2 | 1 | - | - | 806 ksps | - | 2 | 4 | 2 | 36 | QFN | 85°C |
| | CY8C4127LQI-BL483 | 24 | 4.1 | 128 | 16 | - | 2 | 1 | - | 1 | 806 ksps | - | 2 | 4 | 2 | 36 | QFN | 85°C |
| | CY8C4127FNI-BL483 | 24 | 4.1 | 128 | 16 | - | 2 | 1 | - | 1 | 806 ksps | - | 2 | 4 | 2 | 36 | 68-CSP | 85°C |
| | CY8C4127LQI-BL493 | 24 | 4.1 | 128 | 16 | - | 2 | 1 | 1 | 1 | 806 ksps | - | 2 | 4 | 2 | 36 | QFN | 85°C |
| | CY8C4127FNI-BL493 | 24 | 4.1 | 128 | 16 | - | 2 | 1 | 1 | 1 | 806 ksps | - | 2 | 4 | 2 | 36 | 68-CSP | 85°C |
| | CY8C4128LQI-BL473 | 24 | 4.1 | 256 | 32 | - | 2 | - | - | - | 806 ksps | - | 2 | 4 | 2 | 36 | QFN | 85°C |
| | CY8C4128LQI-BL483 | 24 | 4.1 | 256 | 32 | - | 2 | 1 | - | 1 | 806 ksps | - | 2 | 4 | 2 | 36 | QFN | 85°C |
| | CY8C4128LQI-BL543 | 24 | 4.2 | 256 | 32 | - | 2 | - | - | - | 806 ksps | 1 | - | 4 | 2 | 36 | QFN | 85°C |
| | CY8C4128LQI-BL573 | 24 | 4.2 | 256 | 32 | - | 2 | - | - | - | 806 ksps | 1 | 2 | 4 | 2 | 36 | QFN | 85°C |
| | CY8C4128FNI-BL573 | 24 | 4.2 | 256 | 32 | - | 2 | - | - | - | 806 ksps | 1 | 2 | 4 | 2 | 36 | 76-CSP | 85°C |
| | CY8C4128LQI-BL553 | 24 | 4.2 | 256 | 32 | - | 2 | 1 | - | - | 806 ksps | 1 | 2 | 4 | 2 | 36 | QFN | 85°C |
| | CY8C4128LQI-BL563 | 24 | 4.2 | 256 | 32 | - | 2 | - | - | 1 | 806 ksps | 1 | 2 | 4 | 2 | 36 | QFN | 85°C |
| | CY8C4128LQI-BL583 | 24 | 4.2 | 256 | 32 | - | 2 | 1 | - | 1 | 806 ksps | 1 | 2 | 4 | 2 | 36 | QFN | 85°C |
| | CY8C4128LQI-BL593 | 24 | 4.2 | 256 | 32 | - | 2 | 1 | 1 | 1 | 806 ksps | 1 | 2 | 4 | 2 | 36 | QFN | 85°C |

Ordering information

6.1 Ordering code definitions

PSoC™ 4 devices follow the part numbering convention described in the following table. All fields are single-character alphanumeric (0, 1, 2, ..., 9, A,B, ..., Z) unless stated otherwise.

The part numbers are of the form CY8C4ABCDEF-XYZ where the fields are defined as follows.

Example

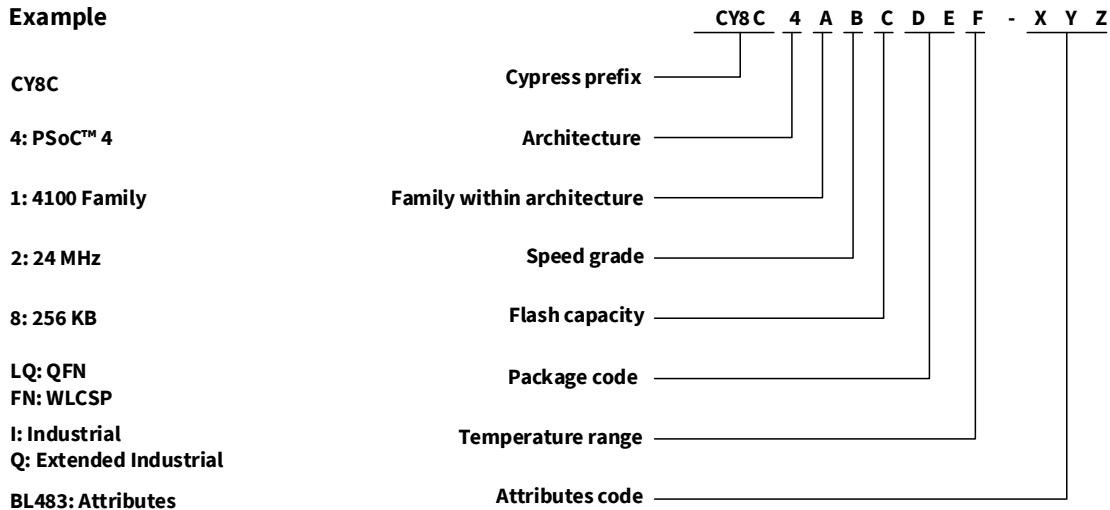

The field values are listed in the following table.

| Field | Description | Values | Meaning |
|-------|----------------------------|-------------|--|
| CY8C | Cypress prefix | | |
| 4 | Architecture | 4 | PSoC™ 4 |
| A | Family within architecture | 1 | PSoC™ 4 CY8C41xx-BL MCU with AIROC™ Bluetooth® LE family |
| B | CPU speed | 2 | 24 MHz |
| C | Flash capacity | 7, 8 | 128KB, 256KB respectively |
| DE | Package code | FN | WLCSP |
| | | LQ | QFN |
| F | Temperature range | I | Industrial 85°C |
| | | Q | Extended Industrial 105°C |
| XYZ | Attributes code | BL400-BL499 | Bluetooth® 4.1 compliant |
| | | BL500-BL599 | Bluetooth® 4.2 compliant |

Packaging

7 Packaging

Table 58 Package characteristics

| Parameter | Description | Conditions | Min | Typ | Max | Unit |
|-----------------|--|------------|-----|-------|-----|---------|
| T _A | Operating ambient temperature | – | –40 | 25.00 | 105 | °C |
| T _J | Operating junction temperature | – | –40 | – | 125 | °C |
| T _{JA} | Package θ _{JA} (56-pin QFN) | – | – | 16.9 | – | °C/watt |
| T _{JC} | Package θ _{JC} (56-pin QFN) | – | – | 9.7 | – | °C/watt |
| T _{JA} | Package θ _{JA} (76-ball WLCSP) | – | – | 20.1 | – | °C/watt |
| T _{JC} | Package θ _{JC} (76-ball WLCSP) | – | – | 0.19 | – | °C/watt |
| T _{JA} | Package θ _{JA} (76-ball thin WLCSP) | – | – | 20.9 | – | °C/watt |
| T _{JC} | Package θ _{JC} (76-ball thin WLCSP) | – | – | 0.17 | – | °C/watt |
| T _{JA} | Package θ _{JA} (68-ball WLCSP) | – | – | 16.6 | – | °C/watt |
| T _{JC} | Package θ _{JC} (68-ball WLCSP) | – | – | 0.19 | – | °C/watt |
| T _{JA} | Package θ _{JA} (68-ball thin WLCSP) | – | – | 16.6 | – | °C/watt |
| T _{JC} | Package θ _{JC} (68-ball thin WLCSP) | – | – | 0.19 | – | °C/watt |

Table 59 Solder reflow peak temperature

| Package | Maximum peak temperature | Maximum time at peak temperature |
|--------------|--------------------------|----------------------------------|
| All packages | 260°C | 30 seconds |

Table 60 Package moisture sensitivity level (MSL), IPC/JEDEC J-STD-2

| Package | MSL |
|--------------------|-------|
| 56-pin QFN | MSL 3 |
| All WLCSP packages | MSL 1 |

Table 61 Package details

| Spec ID | Package | Description |
|-------------------|--------------------|-----------------------------|
| 001-58740 Rev. *C | 56-pin QFN | 7.0 mm × 7.0 mm × 0.6 mm |
| 001-96603 Rev. *B | 76-ball WLCSP | 4.04 mm × 3.87 mm × 0.55 mm |
| 002-10658 Rev. ** | 76-ball thin WLCSP | 4.04 mm × 3.87 mm × 0.4 mm |
| 001-92343 Rev. *A | 68-ball WLCSP | 3.52 mm × 3.91 mm × 0.55 mm |
| 001-99408 Rev. ** | 68-ball thin WLCSP | 52 mm × 3.91 mm × 0.4 mm |

Packaging

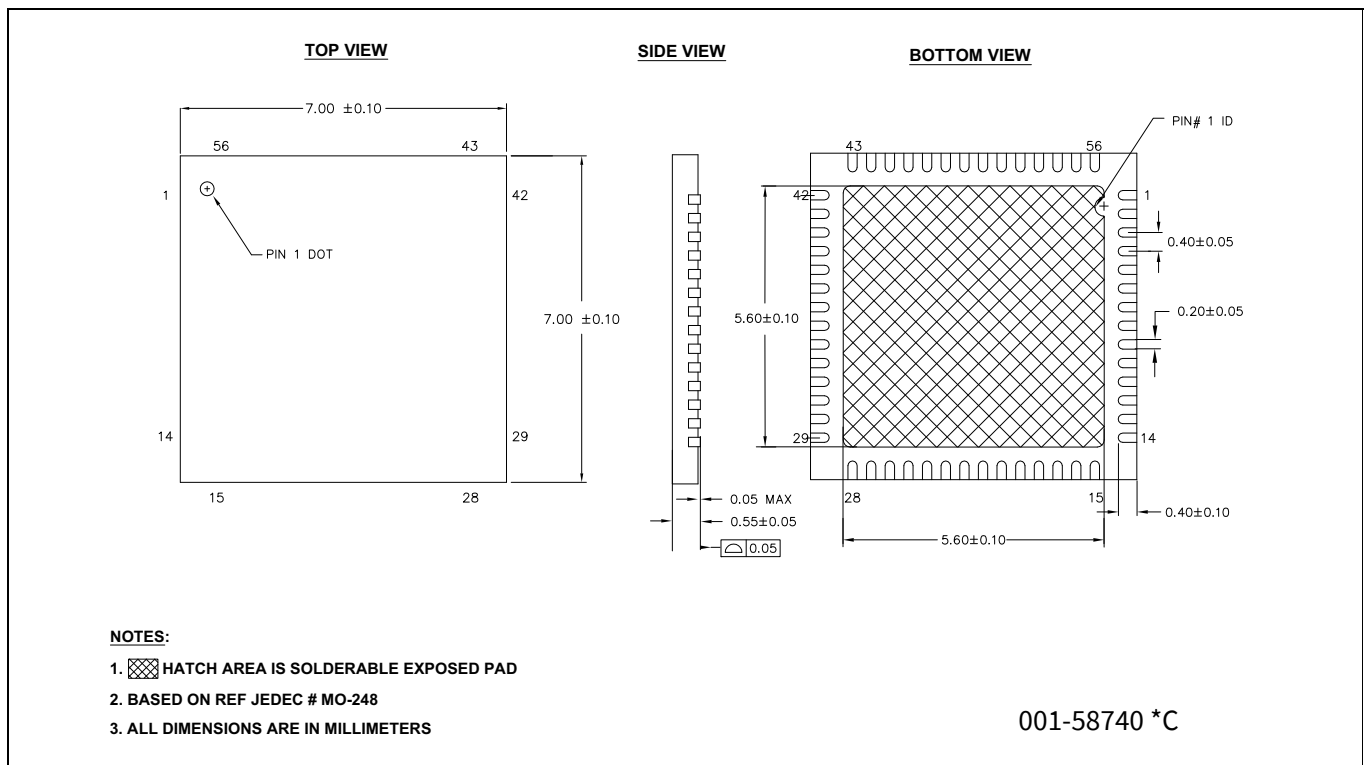

Figure 5 56-pin QFN 7 mm × 7 mm × 0.6 mm

The center pad on the QFN package must be connected to ground (V_{SS}) for the proper operation of the device.

7.1 WLCSP compatibility

The PSoC™ 4XXX-BLE family has products with 128 KB (16KB SRAM) and 256 KB (32KB SRAM) Flash. Package pin-outs and sizes are identical for the 56-pin QFN package but are different in one dimension for the 68-ball WLCSP.

The 256KB Flash product has an extra column of balls which are required for mechanical integrity purposes in the Chip-Scale package. With consideration for this difference, the land pattern on the PCB may be designed such that either product may be used with no change to the PCB design.

Figure 6 shows the 128KB and 256 KB Flash CSP packages.

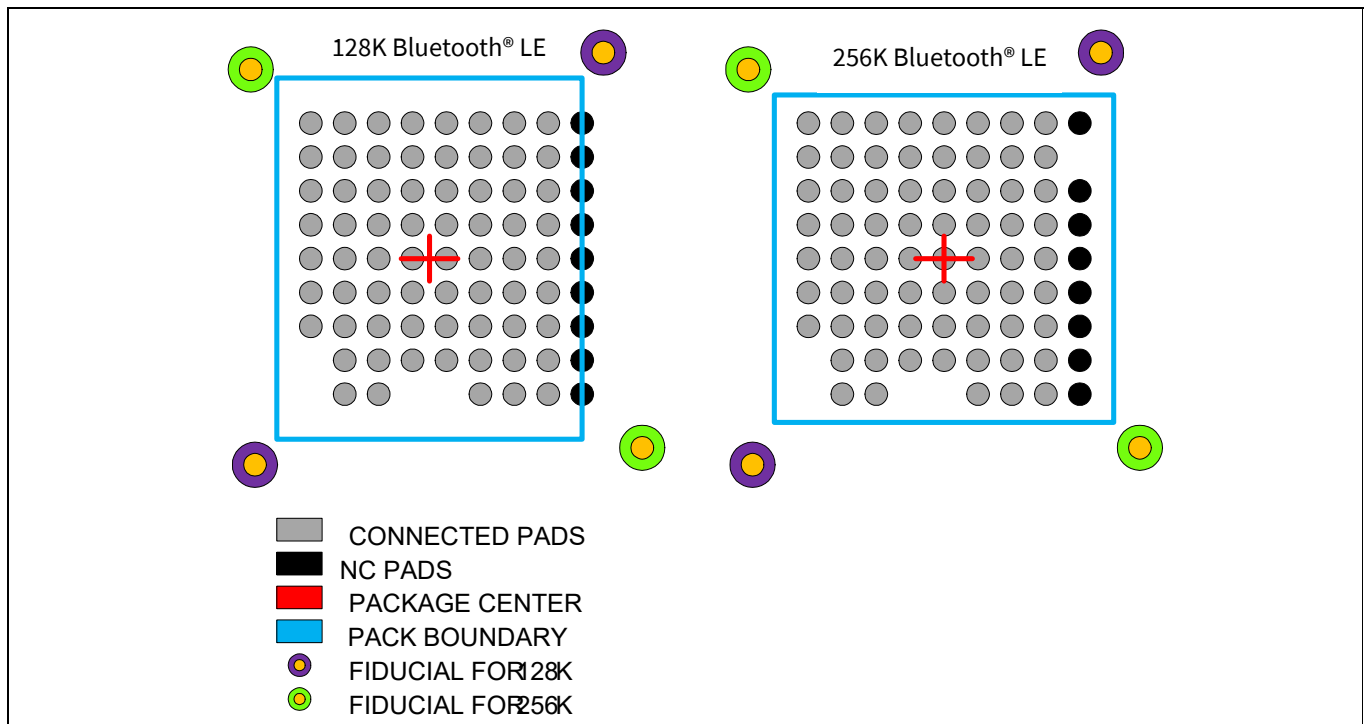

Figure 6 128-KB and 256-KB Flash CSP packages

The rightmost column of (all NC, No Connect) balls in the 256K Bluetooth® LE WLCSP is for mechanical integrity purposes. The package is thus wider (3.2 mm versus 2.8 mm). All other dimensions are identical. Infineon will provide layout symbols for printed circuit board (PCB) layout.

The scheme in **Figure 6** is implemented to design the PCB for the 256K Bluetooth® LE package with the appropriate space requirements thus allowing use of either package at a later time without redesigning the PCB.

Packaging

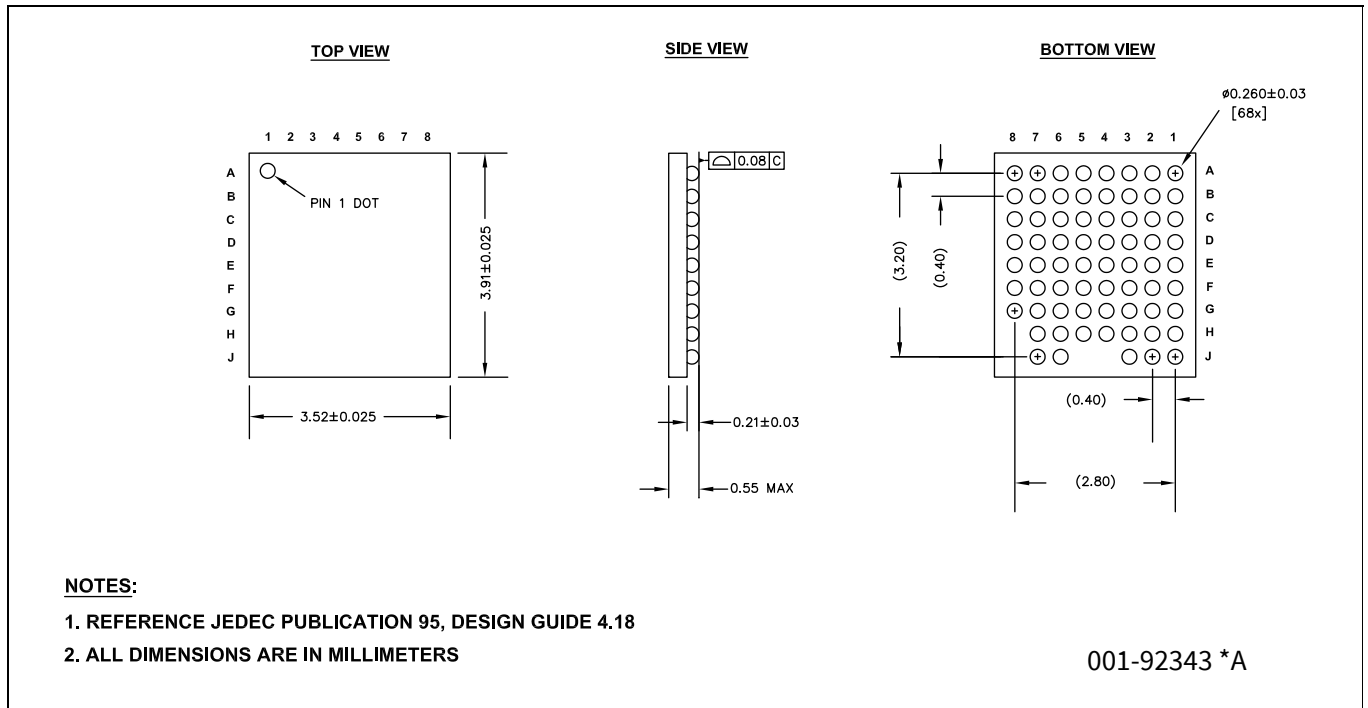

Figure 7 68-ball WLCSP package outline

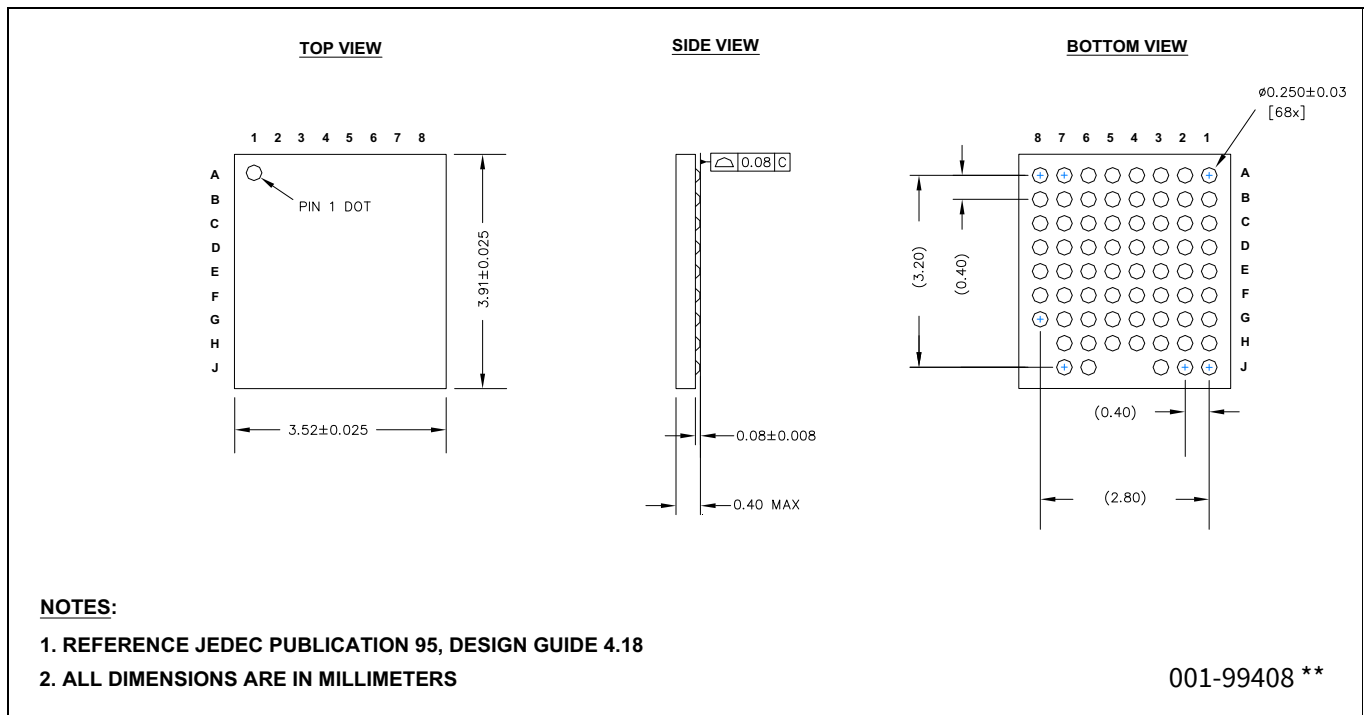
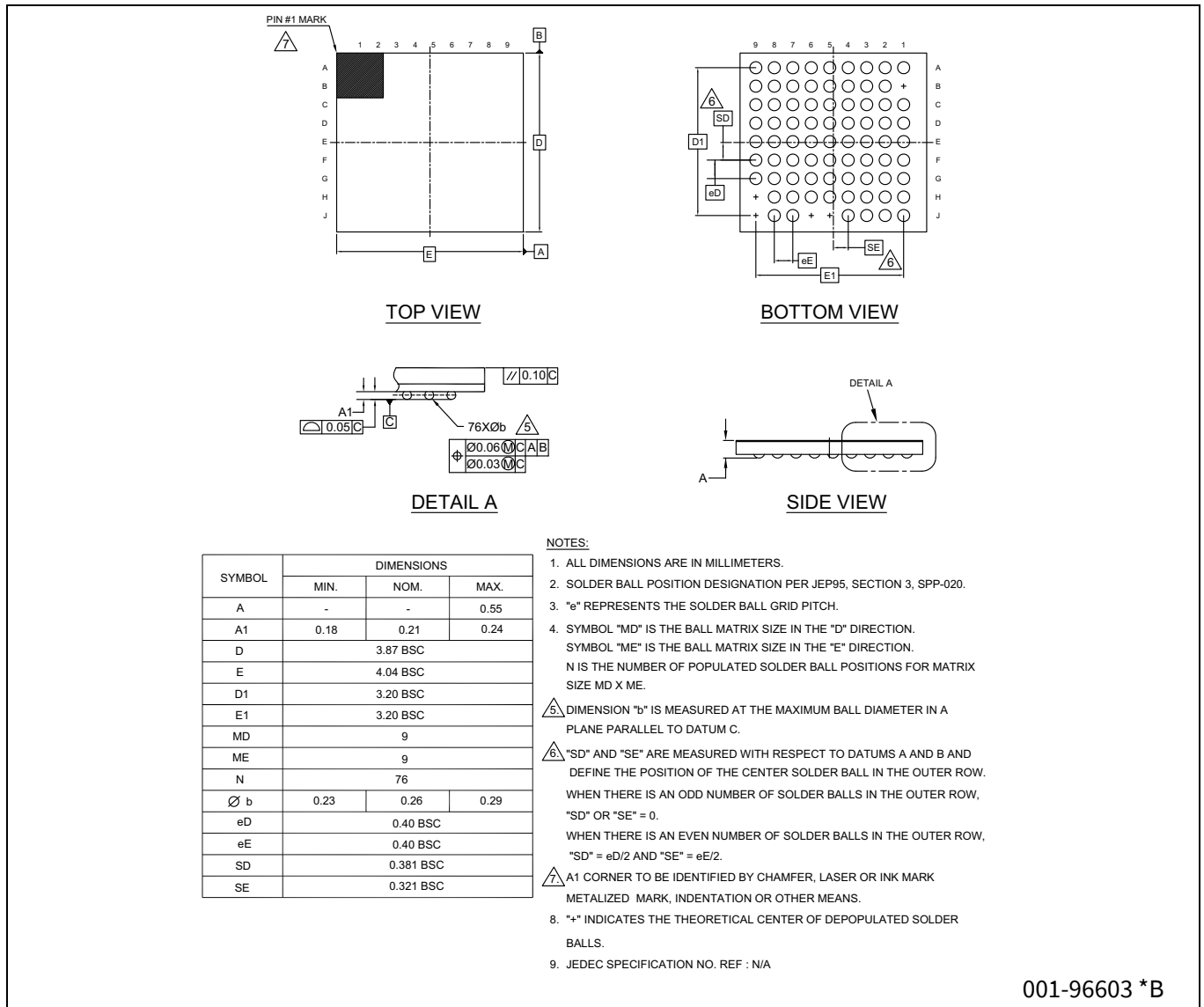

Figure 8 68-ball thin WLCSP

Packaging



001-96603 *B

Figure 9 76-ball WLCSP package outline

Packaging

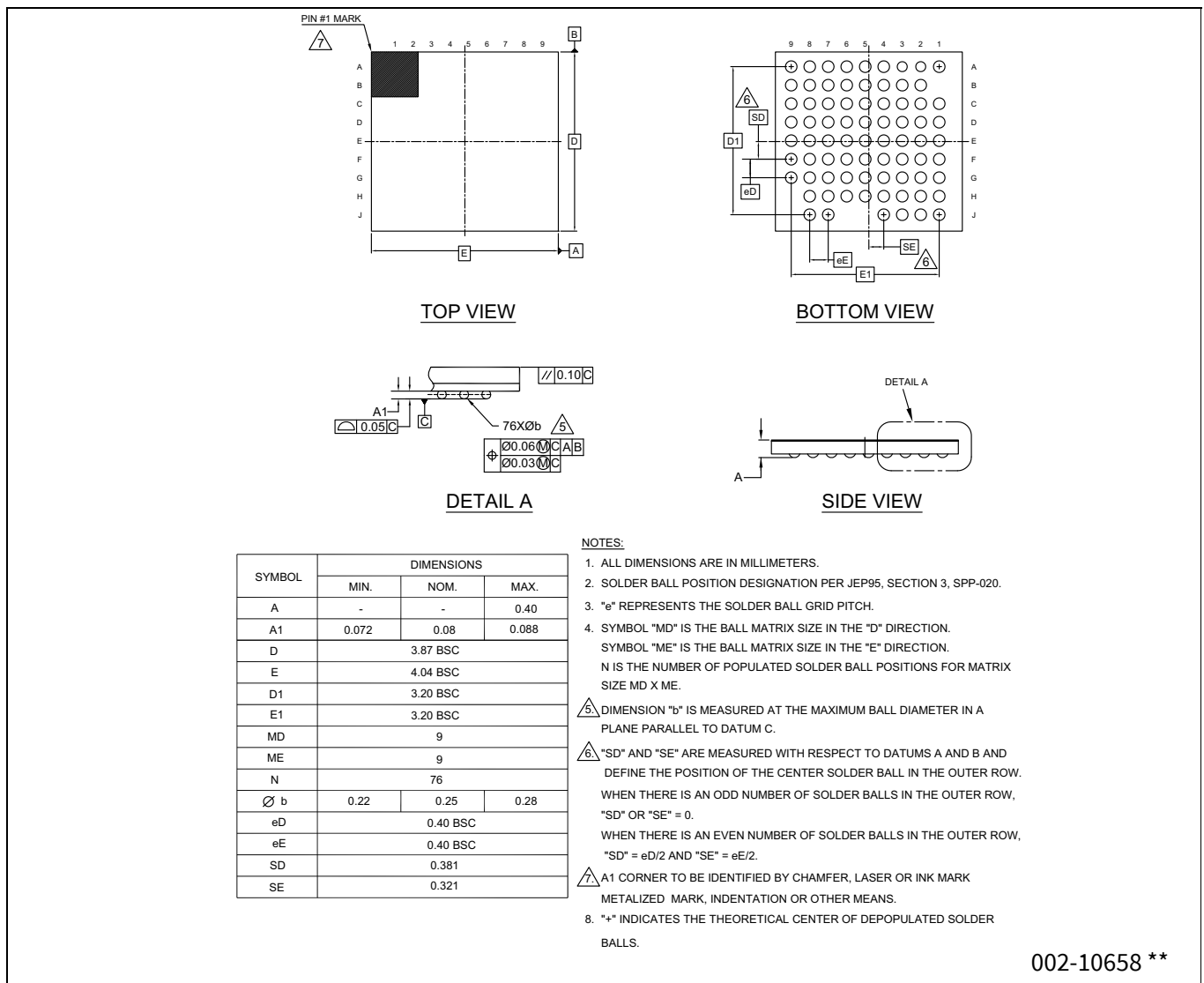

002-10658 **

Figure 10 76-ball thin WLCSP package outline

8 Acronyms

Table 62 Acronyms used in this document

| Acronym | Description |
|----------------|--|
| ABUS | analog local bus |
| ADC | analog-to-digital converter |
| AG | analog global |
| AHB | AMBA (advanced microcontroller bus architecture) high-performance bus, an Arm® data transfer bus |
| ALU | arithmetic logic unit |
| AMUXBUS | analog multiplexer bus |
| API | application programming interface |
| APSR | application program status register |
| Arm® | advanced RISC machine, a CPU architecture |
| ATM | automatic thump mode |
| BW | bandwidth |
| CAN | Controller Area Network, a communications protocol |
| CMRR | common-mode rejection ratio |
| CPU | central processing unit |
| CRC | cyclic redundancy check, an error-checking protocol |
| DAC | digital-to-analog converter, see also IDAC, VDAC |
| DFB | digital filter block |
| DIO | digital input/output, GPIO with only digital capabilities, no analog. See GPIO. |
| DMIPS | Dhrystone million instructions per second |
| DMA | direct memory access, see also TD |
| DNL | differential nonlinearity, see also INL |
| DNU | do not use |
| DR | port write data registers |
| DSI | digital system interconnect |
| DWT | data watchpoint and trace |
| ECC | error correcting code |
| ECO | external crystal oscillator |
| EEPROM | electrically erasable programmable read-only memory |
| EMI | electromagnetic interference |
| EMIF | external memory interface |
| EOC | end of conversion |
| EOF | end of frame |
| EPSR | execution program status register |
| ESD | electrostatic discharge |
| ETM | embedded trace macrocell |
| FET | field-effect transistor |
| FIR | finite impulse response, see also IIR |

Acronyms

Table 62 Acronyms used in this document *(continued)*

| Acronym | Description |
|--------------------------|--|
| FPB | flash patch and breakpoint |
| FS | full-speed |
| GPIO | general-purpose input/output, applies to a PSoC™ pin |
| HCI | host controller interface |
| HVI | high-voltage interrupt, see also LVI, LVD |
| IC | integrated circuit |
| IDAC | current DAC, see also DAC, VDAC |
| IDE | integrated development environment |
| I ² C, or IIC | Inter-Integrated Circuit, a communications protocol |
| IIR | infinite impulse response, see also FIR |
| ILO | internal low-speed oscillator, see also IMO |
| IMO | internal main oscillator, see also ILO |
| INL | integral nonlinearity, see also DNL |
| I/O | input/output, see also GPIO, DIO, SIO, USBIO |
| IPOR | initial power-on reset |
| IPSR | interrupt program status register |
| IRQ | interrupt request |
| ITM | instrumentation trace macrocell |
| LCD | liquid crystal display |
| LIN | Local Interconnect Network, a communications protocol. |
| LR | link register |
| LUT | lookup table |
| LVD | low-voltage detect, see also LVI |
| LVI | low-voltage interrupt, see also HVI |
| LVTTL | low-voltage transistor-transistor logic |
| MAC | multiply-accumulate |
| MCU | microcontroller unit |
| MISO | master-in slave-out |
| NC | no connect |
| NMI | nonmaskable interrupt |
| NRZ | non-return-to-zero |
| NVIC | nested vectored interrupt controller |
| NVL | nonvolatile latch, see also WOL |
| Opamp | operational amplifier |
| PAL | programmable array logic, see also PLD |
| PC | program counter |
| PCB | printed circuit board |
| PGA | programmable gain amplifier |
| PHUB | peripheral hub |
| PHY | physical layer |

Acronyms

Table 62 Acronyms used in this document *(continued)*

| Acronym | Description |
|---------|--|
| PICU | port interrupt control unit |
| PLA | programmable logic array |
| PLD | programmable logic device, see also PAL |
| PLL | phase-locked loop |
| PMDD | package material declaration data sheet |
| POR | power-on reset |
| PRES | precise power-on reset |
| PRS | pseudo random sequence |
| PS | port read data register |
| PSoC™ | Programmable system on chip |
| PSRR | power supply rejection ratio |
| PWM | pulse-width modulator |
| RAM | random-access memory |
| RISC | reduced-instruction-set computing |
| RMS | root-mean-square |
| RTC | real-time clock |
| RTL | register transfer language |
| RTR | remote transmission request |
| RX | receive |
| SAR | successive approximation register |
| SC/CT | switched capacitor/continuous time |
| SCL | I ² C serial clock |
| SDA | I ² C serial data |
| S/H | sample and hold |
| SINAD | signal to noise and distortion ratio |
| SIO | special input/output, GPIO with advanced features. See GPIO. |
| SOC | start of conversion |
| SOF | start of frame |
| SPI | Serial Peripheral Interface, a communications protocol |
| SR | slew rate |
| SRAM | static random access memory |
| SRES | software reset |
| STN | super twisted nematic |
| SWD | serial wire debug, a test protocol |
| SWV | single-wire viewer |
| TD | transaction descriptor, see also DMA |
| THD | total harmonic distortion |
| TIA | transimpedance amplifier |
| TN | twisted nematic |
| TRM | technical reference manual |

Acronyms

Table 62 **Acronyms used in this document** *(continued)*

| Acronym | Description |
|----------------|--|
| TTL | transistor-transistor logic |
| TX | transmit |
| UART | Universal Asynchronous Transmitter Receiver, a communications protocol |
| WOL | write once latch, see also NVL |
| WRES | watchdog timer reset |
| XRES | external reset I/O pin |
| XTAL | crystal |
| UDB | universal digital block |
| USB | Universal Serial Bus |
| USBIO | USB input/output, PSoC™ pins used to connect to a USB port |
| VDAC | voltage DAC, see also DAC, IDAC |
| WDT | watchdog timer |

9 Document conventions

9.1 Units of measure

Table 63 Units of measure

| Symbol | Units of measure |
|--------|------------------------|
| °C | degrees Celsius |
| dB | decibel |
| dBm | decibel-milliwatts |
| fF | femtofarads |
| Hz | hertz |
| KB | 1024 bytes |
| kbps | kilobits per second |
| Khr | kilohour |
| kHz | kilohertz |
| kΩ | kilo ohm |
| ksps | kilosamples per second |
| LSB | least significant bit |
| Mbps | megabits per second |
| MHz | megahertz |
| MΩ | mega-ohm |
| Msps | megasamples per second |
| μA | microampere |
| μF | microfarad |
| μH | microhenry |
| μs | microsecond |
| μV | microvolt |
| μW | microwatt |
| mA | milliampere |
| ms | millisecond |
| mV | millivolt |
| nA | nanoampere |
| ns | nanosecond |
| nV | nanovolt |
| Ω | ohm |
| pF | picofarad |
| ppm | parts per million |
| ps | picosecond |
| s | second |
| sps | samples per second |
| sqrtHz | square root of hertz |
| V | volt |

Revision history

| Document revision | Date | Description of changes |
|-------------------|------------|---|
| ** | 2018-02-22 | New datasheet |
| *A | 2021-06-16 | Updated datasheet to IFX template. Changed title to “PSoC™ 4 CY8C41xx-BL MCU with AIROC™ Bluetooth® LE Family Datasheet”. |
| *B | 2023-03-29 | Updated to the latest template Added Table 3 for 76-ball WLCSP package Removed the following part numbers from Table 57 : CY8C4128FNI-BL543, CY8C4128FNI-BL553, CY8C4128FNI-BL563, CY8C4128FNI-BL583, and CY8C4128FNI-BL593 |

Trademarks

All referenced product or service names and trademarks are the property of their respective owners.

Edition 2023-03-29

Published by

**Infineon Technologies AG
81726 Munich, Germany**

**© 2023 Infineon Technologies AG.
All Rights Reserved.**

Do you have a question about this document?

Email:

erratum@infineon.com

Document reference

002-23052 Rev. *B

IMPORTANT NOTICE

The information given in this document shall in no event be regarded as a guarantee of conditions or characteristics ("Beschaffenheitsgarantie").

With respect to any examples, hints or any typical values stated herein and/or any information regarding the application of the product, Infineon Technologies hereby disclaims any and all warranties and liabilities of any kind, including without limitation warranties of non-infringement of intellectual property rights of any third party.

In addition, any information given in this document is subject to customer's compliance with its obligations stated in this document and any applicable legal requirements, norms and standards concerning customer's products and any use of the product of Infineon Technologies in customer's applications.

The data contained in this document is exclusively intended for technically trained staff. It is the responsibility of customer's technical departments to evaluate the suitability of the product for the intended application and the completeness of the product information given in this document with respect to such application.

WARNINGS

Due to technical requirements products may contain dangerous substances. For information on the types in question please contact your nearest Infineon Technologies office.

Except as otherwise explicitly approved by Infineon Technologies in a written document signed by authorized representatives of Infineon Technologies, Infineon Technologies' products may not be used in any applications where a failure of the product or any consequences of the use thereof can reasonably be expected to result in personal injury.

Looking for pricing, stock, or lifecycle information?

Click below to explore more details on WIN SOURCE:

- ⊖ [View CY8C4127LQI-BL483 on WIN SOURCE](#)
- ⊖ [Infineon Technologies Information](#)

Optimize Your Supply Chain with WIN SOURCE Solutions

- ✓ Global Sourcing Solution
- ✓ Obsolete Management
- ✓ Cost Control Management
- ✓ Shortage Management
- ✓ Alternative Solution
- ✓ Excess Inventory Management