



**THE DATASHEET OF  
BQ7693001DBTR**



# BQ769x0 3-Series to 15-Series Cell Battery Monitor Family for Li-Ion and Phosphate Applications

## 1 Features

- AFE monitoring features
  - Pure digital interface
  - Internal ADC measures cell voltage, die temperature, and external thermistor
  - A separate, internal ADC measures pack current (coulomb counter)
  - Directly supports up to three thermistors (103AT)
- Hardware protection features
  - Overcurrent in Discharge (OCD)
  - Short Circuit in Discharge (SCD)
  - Overvoltage (OV)
  - Undervoltage (UV)
  - Secondary protector fault detection
- Additional features
  - Integrated cell balancing FETs
  - Charge, discharge low-side NCH FET drivers
  - Alert interrupt to host microcontroller
  - 2.5-V or 3.3-V output voltage regulator
  - No EEPROM programming necessary
  - High supply voltage absolute maximum (up to 108 V)
  - Simple I<sup>2</sup>C compatible interface (CRC option)
  - Random cell connection tolerant

## 3 Description

The BQ769x0 family of robust analog front-end (AFE) devices serves as part of a complete pack monitoring and protection solution for next-generation, high-power systems, such as light electric vehicles, power tools, and uninterruptible power supplies. The BQ769x0 is designed with low power in mind: Sub-blocks within the IC may be enabled or disabled to control the overall chip current consumption, and a SHIP mode provides a simple way to put the pack into an ultra-low power state.

The BQ76920 device supports up to 5-series cells or typical 18-V packs, the BQ76930 handles up to 10-series cells or typical 36-V packs, and the BQ76940 works for up to 15-series cells or typical 48-V packs. A variety of battery chemistries may be managed with these AFEs, including Li-ion, Li-iron phosphate, and more. Through I<sup>2</sup>C, a host controller can use the BQ769x0 to implement many battery pack management functions, such as monitoring (cell voltages, pack current, pack temperatures), protection (controlling charge/discharge FETs), and balancing. Integrated A/D converters enable a purely digital readout of critical system parameters, with calibration handled in TI's manufacturing process.

## 2 Applications

- [Light electric vehicles \(LEV\): eBikes, eScooters, pedelec, and pedal-assist bicycles](#)
- [Power tools and garden tools](#)
- [Battery backup units \(BBUS\), energy storage systems \(ESS\), and uninterruptible power supply \(UPS\) systems](#)
- [Other industrial battery packs \(≥10S\)](#)

### Device Information

PART NUMBER <sup>1</sup>	PACKAGE	BODY SIZE (NOM)
BQ76920	TSSOP (20)	6.50 mm × 4.40 mm
BQ76930	TSSOP (30)	7.80 mm × 4.40 mm
BQ76940	TSSOP (44)	11.00 mm × 4.40 mm

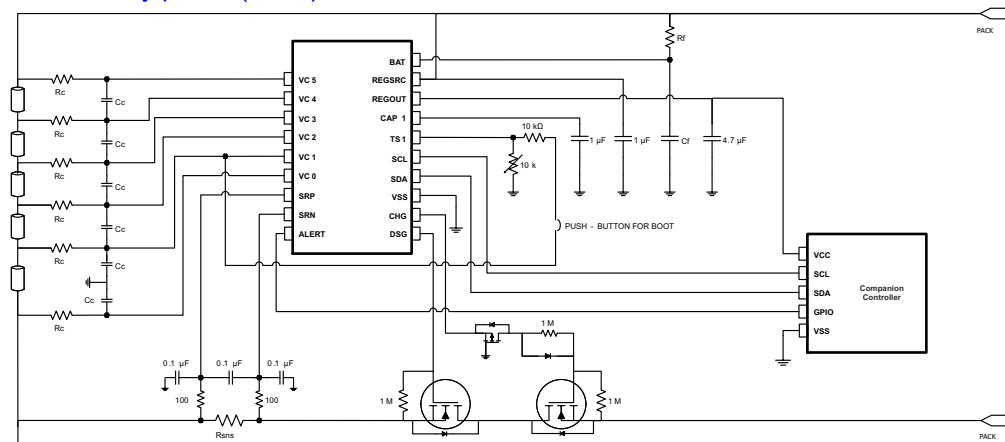

**Simplified Schematic**



## Table of Contents

<b>1 Features</b> .....	1	8.2 Functional Block Diagram.....	16
<b>2 Applications</b> .....	1	8.3 Feature Description.....	17
<b>3 Description</b> .....	1	8.4 Device Functional Modes.....	27
<b>4 Revision History</b> .....	2	8.5 Register Maps.....	29
<b>5 Device Comparison Table</b> .....	3	<b>9 Application and Implementation</b> .....	38
<b>6 Pin Configuration and Functions</b> .....	3	9.1 Application Information.....	38
6.1 Versions.....	3	9.2 Typical Applications .....	41
6.2 BQ76920 Pin Diagram.....	4	<b>10 Power Supply Recommendations</b> .....	46
6.3 BQ76930 Pin Diagram.....	5	<b>11 Layout</b> .....	47
6.4 BQ76940 Pin Diagram.....	6	11.1 Layout Guidelines.....	47
<b>7 Specifications</b> .....	8	11.2 Layout Example.....	47
7.1 Absolute Maximum Ratings.....	8	<b>12 Device and Documentation Support</b> .....	49
7.2 ESD Ratings.....	8	12.1 Third-Party Products Disclaimer.....	49
7.3 Recommended Operating Conditions.....	9	12.2 Documentation Support.....	49
7.4 Thermal Information.....	10	12.3 Related Links.....	49
7.5 Electrical Characteristics.....	10	12.4 Receiving Notification of Documentation Updates.....	49
7.6 Timing Requirements.....	14	12.5 Trademarks.....	49
7.7 Typical Characteristics.....	15	<b>13 Mechanical, Packaging, and Orderable Information</b> .....	49
<b>8 Detailed Description</b> .....	16		
8.1 Overview.....	16		

## 4 Revision History

NOTE: Page numbers for previous revisions may differ from page numbers in the current version.

Changes from Revision H (March 2019) to Revision I (March 2022)	Page
• Changed the formatting throughout .....	1
• Added VCn rows in <i>Absolute Maximum Ratings</i> table.....	8
• Changed tablenote for POR and referenced entries.....	10
• Changed the scale in the VCx and OV Protection plots .....	15
• Updated <a href="#">16-Bit Pack Voltage</a> .....	21
• Changed "OV Trip" to "UV Trip" in the description of undervoltage protection.....	21
• Changed the LSB bit count from 2 to 4 for the OV_TRIP register.....	30
• Updated <a href="#">Application Information</a> .....	38
• Added <a href="#">Device Timing</a> .....	38
• Added <a href="#">Random Cell Connection</a> .....	38
• Added <a href="#">Power Pin Diodes</a> .....	38
• Added <a href="#">Alert Pin</a> .....	38
• Added <a href="#">Sense Inputs</a> .....	38
• Added <a href="#">TSn Pins</a> .....	38
• Updated <a href="#">Unused Pins</a> .....	39
• Updated <a href="#">Step-by-Step Design Procedure</a> .....	45

Changes from Revision G (April 2016) to Revision H (March 2019)	Page
• Changed <a href="#">Applications</a> .....	1
• Changed the <a href="#">Description</a> .....	1
• Added <a href="#">High-Side FET Driving</a> .....	23
• Added the link to the <i>BQ769x0 Boot Switch Alternatives Application Report</i> .....	27
• Added the link to the <i>BQ769x0 Family Top Design Considerations Application Report</i> .....	38
• Added <a href="#">Figure 9-4</a> to provide an example of a high-side FET configuration.....	41
• Added <i>BQ769x0 Family Top Design Considerations Application Report</i> link.....	46

## 5 Device Comparison Table

TUBE	TAPE & REEL	CELLS	I <sup>2</sup> C ADDRESS (7-Bit)	LDO (V)	CRC	PACKAGE
BQ7692000PW	BQ7692000PWR	3–5	0x08	2.5	No	20-TSSOP (PW)
BQ7692001PW <sup>(1)</sup>	BQ7692001PWR <sup>(1)</sup>				Yes	
BQ7692002PW <sup>(1)</sup>	BQ7692002PWR <sup>(1)</sup>			3.3	No	
BQ7692003PW	BQ7692003PWR				Yes	
BQ7692006PW	BQ7692006PWR				No	
BQ7693000DBT	BQ7693000DBTR	6–10	0x08	2.5	No	30-TSSOP (DBT)
BQ7693001DBT	BQ7693001DBTR				Yes	
BQ7693002DBT	BQ7693002DBTR			3.3	No	
BQ7693003DBT	BQ7693003DBTR				Yes	
BQ7693006DBT	BQ7693006DBTR				No	
BQ7693007DBT	BQ7693007DBTR	Yes				
BQ7694000DBT	BQ7694000DBTR	9–15	0x08	2.5	No	44-TSSOP (DBT)
BQ7694001DBT	BQ7694001DBTR				Yes	
BQ7694002DBT	BQ7694002DBTR			3.3	No	
BQ7694003DBT	BQ7694003DBTR				Yes	
BQ7694006DBT	BQ7694006DBTR				No	

(1) Product Preview only

Texas Instruments preconfigures the BQ769x0 devices for a specific I<sup>2</sup>C address, LDO voltage, and more. These settings are permanently stored in EEPROM and cannot be further modified.

Contact Texas Instruments for other options not listed above, as well as any options noted as “Product Preview only.”

## 6 Pin Configuration and Functions

### 6.1 Versions

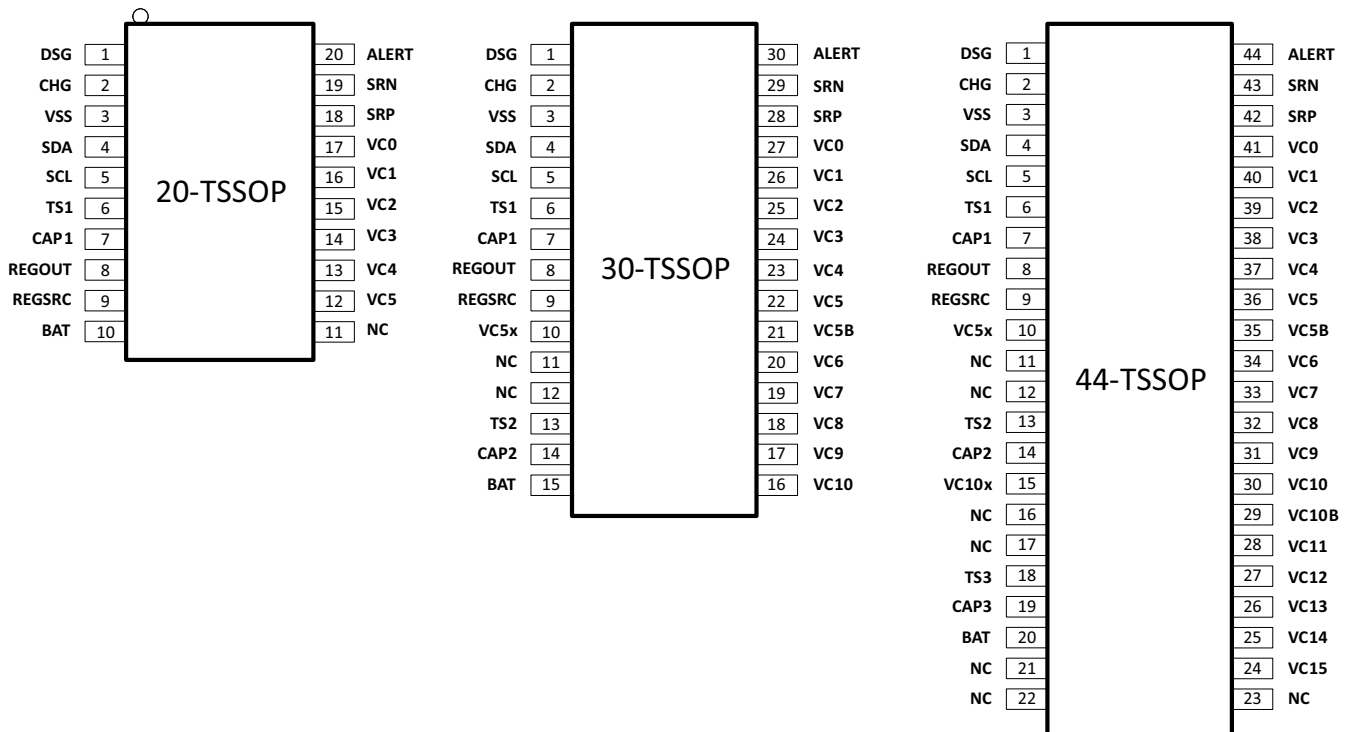

BQ76920: 3–5 Series Cells (20-TSSOP)

**BQ76920, BQ76930, BQ76940**

SLUSBK2I – OCTOBER 2013 – REVISED MARCH 2022

- 6.5 mm x 4.4 mm x 1.2 mm

BQ76930: 6–10 Series Cells (30-TSSOP)

- 7.8 mm x 4.4 mm x 1.2 mm

BQ76940: 9–15 Series Cells (44-TSSOP)

- 11.3 mm x 4.4 mm x 1.2 mm

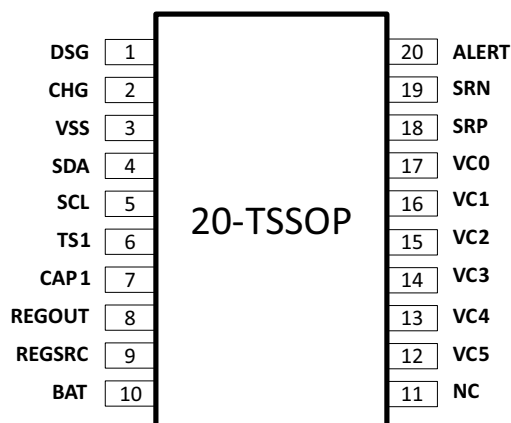
**6.2 BQ76920 Pin Diagram**

**Table 6-1. BQ76920 Pin Functions**

PIN	NAME	TYPE	DESCRIPTION
1	DSG	O	Discharge FET driver
2	CHG	O	Charge FET driver
3	VSS	—	Chip VSS
4	SDA	I/O	I <sup>2</sup> C communication to the host controller
5	SCL	I	I <sup>2</sup> C communication to the host controller
6	TS1	I	Thermistor #1 positive terminal <sup>(1)</sup>
7	CAP1	O	Capacitor to VSS
8	REGOUT	P	Output LDO
9	REGSRC	I	Input source for output LDO
10	BAT	P	Battery (top-most) terminal
11	NC	—	No connect
12	VC5	I	Sense voltage for 5th cell positive terminal
13	VC4	I	Sense voltage for 4th cell positive terminal
14	VC3	I	Sense voltage for 3rd cell positive terminal
15	VC2	I	Sense voltage for 2nd cell positive terminal
16	VC1	I	Sense voltage for 1st cell positive terminal
17	VC0	I	Sense voltage for 1st cell negative terminal
18	SRP	I	Negative current sense (nearest VSS)
19	SRN	I	Positive current sense
20	ALERT	I/O	Alert output and override input

(1) If not used, pull down to VSS with a 10-kΩ nominal resistor.

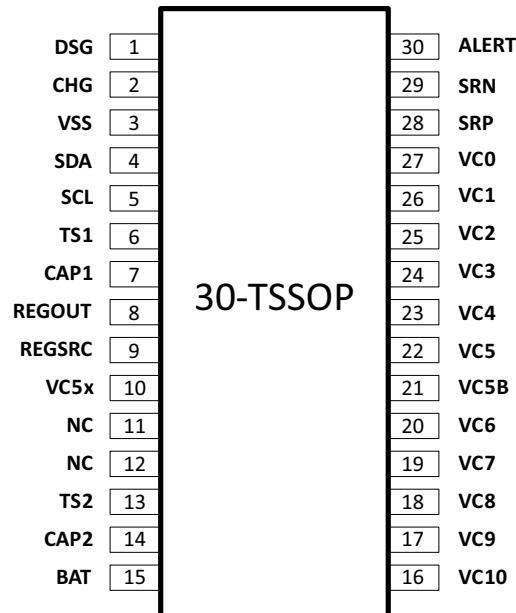
### 6.3 BQ76930 Pin Diagram



**Table 6-2. BQ76930 Pin Functions**

PIN	NAME	TYPE	DESCRIPTION
1	DSG	O	Discharge FET driver
2	CHG	O	Charge FET driver
3	VSS	—	Chip VSS
4	SDA	I/O	I <sup>2</sup> C communication to the host controller
5	SCL	I	I <sup>2</sup> C communication to the host controller
6	TS1	I	Thermistor #1 positive terminal <sup>(1)</sup>
7	CAP1	O	Capacitor to VSS
8	REGOUT	P	Output LDO
9	REGSRC	I	Input source for output LDO
10	VC5X	P	Thermistor #2 negative terminal
11	NC	—	No connect (short to CAP2)
12	NC	—	No connect (short to CAP2)
13	TS2	I	Thermistor #2 positive terminal <sup>(1)</sup>
14	CAP2	O	Capacitor to VC5X
15	BAT	P	Battery (top-most) terminal
16	VC10	I	Sense voltage for 10th cell positive terminal
17	VC9	I	Sense voltage for 9th cell positive terminal
18	VC8	I	Sense voltage for 8th cell positive terminal
19	VC7	I	Sense voltage for 7th cell positive terminal
20	VC6	I	Sense voltage for 6th cell positive terminal
21	VC5B	I	Sense voltage for 6th cell negative terminal
22	VC5	I	Sense voltage for 5th cell positive terminal
23	VC4	I	Sense voltage for 4th cell positive terminal
24	VC3	I	Sense voltage for 3rd cell positive terminal
25	VC2	I	Sense voltage for 2nd cell positive terminal
26	VC1	I	Sense voltage for 1st cell positive terminal
27	VC0	I	Sense voltage for 1st cell negative terminal

**Table 6-2. BQ76930 Pin Functions (continued)**

PIN	NAME	TYPE	DESCRIPTION
28	SRP	I	Negative current sense (nearest VSS)
29	SRN	I	Positive current sense
30	ALERT	I/O	Alert output and override input

(1) If not used, pull down to group ground reference (VSS for TS1 and VC5X for TS2) with a 10-kΩ nominal resistor.

### 6.4 BQ76940 Pin Diagram

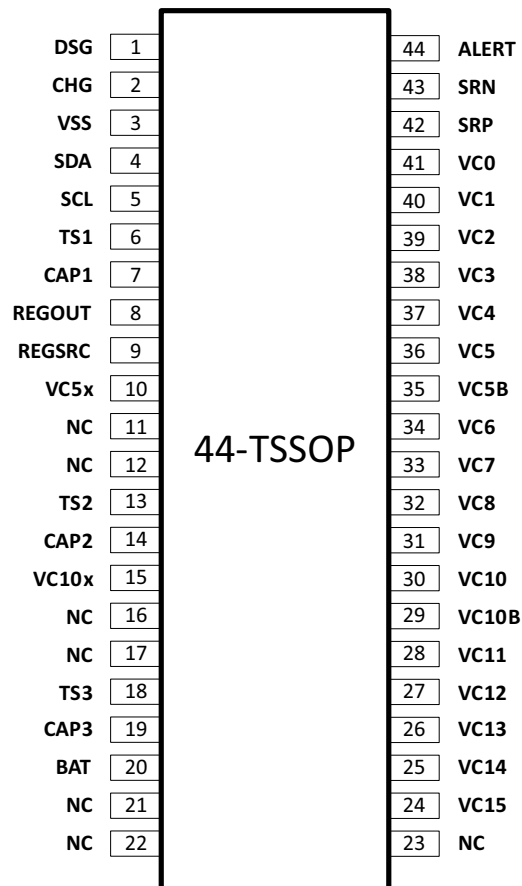

**BQ76940 Pin Functions**

PIN	NAME	TYPE	DESCRIPTION
1	DSG	O	Discharge FET driver
2	CHG	O	Charge FET driver
3	VSS	—	Chip VSS
4	SDA	I/O	I <sup>2</sup> C communication to the host controller
5	SCL	I	I <sup>2</sup> C communication to the host controller
6	TS1	I	Thermistor #1 positive terminal <sup>(1)</sup>
7	CAP1	O	Capacitor to VSS
8	REGOUT	P	Output LDO
9	REGSRC	I	Input source for output LDO
10	VC5X	P	Thermistor #2 negative terminal
11	NC	—	No connect (short to CAP2)
12	NC	—	No connect (short to CAP2)
13	TS2	I	Thermistor #2 positive terminal <sup>(1)</sup>

**BQ76940 Pin Functions (continued)**

PIN	NAME	TYPE	DESCRIPTION
14	CAP2	O	Capacitor to VC5X
15	VC10X	P	Thermistor #3 negative terminal
16	NC	—	No connect (short to CAP3)
17	NC	—	No connect (short to CAP3)
18	TS3	I	Thermistor #3 positive terminal <sup>(1)</sup>
19	CAP3	O	Capacitor to VC10X
20	BAT	P	Battery (top-most) terminal
21	NC	—	No connect
22	NC	—	No connect
23	NC	—	No connect
24	VC15	I	Sense voltage for 15th cell positive terminal
25	VC14	I	Sense voltage for 14th cell positive terminal
26	VC13	I	Sense voltage for 13th cell positive terminal
27	VC12	I	Sense voltage for 12th cell positive terminal
28	VC11	I	Sense voltage for 11th cell positive terminal
29	VC10B	I	Sense voltage for 11th cell negative terminal
30	VC10	I	Sense voltage for 10th cell positive terminal
31	VC9	I	Sense voltage for 9th cell positive terminal
32	VC8	I	Sense voltage for 8th cell positive terminal
33	VC7	I	Sense voltage for 7th cell positive terminal
34	VC6	I	Sense voltage for 6th cell positive terminal
35	VC5B	I	Sense voltage for 6th cell negative terminal
36	VC5	I	Sense voltage for 5th cell positive terminal
37	VC4	I	Sense voltage for 4th cell positive terminal
38	VC3	I	Sense voltage for 3rd cell positive terminal
39	VC2	I	Sense voltage for 2nd cell positive terminal
40	VC1	I	Sense voltage for 1st cell positive terminal
41	VC0	I	Sense voltage for 1st cell negative terminal
42	SRP	I	Negative current sense (nearest VSS)
43	SRN	I	Positive current sense
44	ALERT	I/O	Alert output and override input

(1) If not used, pull down to group ground reference (VSS for TS1, VC5X for TS2, and VC10X for TS3) with a 10-kΩ nominal resistor.

## 7 Specifications

### 7.1 Absolute Maximum Ratings

Over-operating free-air temperature range (unless otherwise noted) <sup>(1)</sup>

			MIN	MAX	UNIT	
V <sub>BAT</sub>	Supply voltage	(BAT–VSS)				
		(BAT–VC5x), (VC5x–VSS)	–0.3	36	V	
		(BAT–VC10x), (VC10x–VC5x), (VC5x–VSS)				
V <sub>I</sub>	Input voltage	(VCn–VSS) where n = 1..5	–0.3	(n × 7.2)	V	
		(VCn–VC5x) where n = 6..10		(n–5) × 7.2		
		(VCn–VC10x) where n = 11..15		(n–10) × 7.2		
		Cell input pins, differential (VCn–VCn–1) where n = 1..15/10/5 (BQ76940/BQ76930/BQ76920, respectively)		–0.3	9	V
		SRN, SRP, SCL, SDA				
		(VC0–VSS), (CAP1–VSS), (TS1–VSS) <sup>(2)</sup>		–0.3	3.6	V
		(VC0–VSS), (VC5b–VC5x), (CAP2–VC5x), (CAP1–VSS), (TS2–VC5x), (TS1–VSS) <sup>(2)</sup>				
(VC0–VSS), (VC5b–VC5x), (VC10b–VC10x), (CAP3–VC10x), (CAP2–VC5x), (CAP1–VSS), (TS3–VC10x), (TS2–VC5x), (TS1–VSS) <sup>(2)</sup>						
REGSRC		–0.3	36			
V <sub>O</sub>	Output voltage	REGOUT, ALERT	–0.3	3.6	V	
		DSG	–0.3	20		
		CHG	–0.3	V <sub>CHGCLAMP</sub>		
I <sub>CB</sub>	Cell balancing current (per cell)	BQ76920	70	mA		
		BQ76930, BQ76940	5	mA		
I <sub>DSG</sub>	Discharge pin input current when disabled (measured into terminal)		7	mA		
T <sub>STG</sub>	Storage temperature		–65	150	°C	
	Lead temperature (soldering, 10 s)			300		

- (1) Operation outside the Absolute Maximum Ratings may cause permanent device damage. Absolute Maximum Ratings do not imply functional operation of the device at these or any other conditions beyond those listed under Recommended Operating Conditions. If outside the Recommended Operating Conditions but within the Absolute Maximum Ratings, the device may not be fully functional, and this may affect device reliability, functionality, performance, and shorten the device lifetime.
- (2) The Absolute Maximum Ratings for (TS1–VSS) apply after the device completes POR and should be observed after t<sub>BOOTREADY</sub> (10 ms), following the application of the boot signal on TS1. Prior to completion of POR, TS1 should not exceed 5 V.

### 7.2 ESD Ratings

			VALUE	UNIT
V <sub>(ESD)</sub>	Electrostatic discharge	Human body model (HBM) ESD stress voltage <sup>(1)</sup>	±2	kV
		Charged device model (CDM) ESD stress voltage <sup>(2)</sup>	±500	V

- (1) JEDEC document JEP155 states that 500-V HBM allows safe manufacturing with a standard ESD control process.
- (2) JEDEC document JEP157 states that 250-V CDM allows safe manufacturing with a standard ESD control process.

### 7.3 Recommended Operating Conditions

Over-operating free-air temperature range (unless otherwise noted). See [Section 9.1.8](#) for more information on cell configurations. All voltages are relative to VSS, except "Cell input differential."

			MIN	TYP	MAX	UNIT	
V <sub>BAT</sub>	Supply voltage	(BAT–VSS)	6		25	V	
		(BAT–VC5x), (VC5x–VSS)					BQ76930
		(BAT–VC10x), (VC10x–VC5x), (VC5x–VSS)					BQ76940
V <sub>IN</sub>	Input voltage	Cell input pins, differential (VC <sub>n</sub> –VC <sub>n–1</sub> ) where n = 1..15/10/5 (BQ76940/BQ76930/BQ76920, respectively), in-use cells only	2		5	V	
		(VC <sub>n</sub> –VSS) where n = 1..5	0		5 × n	V	
		(VC <sub>n</sub> –VSS) where n = 1..5, (VC <sub>n</sub> –VC5x) where n = 6..10					BQ76930
		(VC <sub>n</sub> –VSS) where n = 1..5, (VC <sub>n</sub> –VC5x) where n = 6..10, (VC <sub>n</sub> –VC10x) where n = 11..15					BQ76940
		SRP	–10		10	mV	
		(VC0–VSS)					BQ76920
		(VC0–VSS), (VC5b–VC5x)					BQ76930
		(VC0–VSS), (VC5b–VC5x), (VC10b–VC10x)	BQ76940				
		SRN	–200		200	mV	
		SCL, SDA	0		3.6	V	
		(TS1–VSS)					BQ76920
		(TS1–VSS), (TS2–VC5x)					BQ76930
		(TS1–VSS), (TS2–VC5x), (TS3–VC10x)	BQ76940				
REGSRC	6		25				
V <sub>OUT</sub>	Output voltage	CHG, DSG	0		16	V	
		REGOUT, ALERT	0		3.6	V	
		(CAP1–VSS)					BQ76920
		(CAP1–VSS), (CAP2–VC5x)					BQ76930
		(CAP1–VSS), (CAP2–VC5x), (CAP3–VC10x)					BQ76940
I <sub>CB</sub>	Cell balancing current (internal, per cell)	BQ76920	0		50	mA	
		BQ76930, BQ76940	0		5	mA	
R <sub>C</sub>	External cell input resistance	BQ76920	40	100	1K	Ω	
		BQ76930, BQ76940	500	1K	1K	Ω	
C <sub>C</sub>	External cell input capacitance	0.1	1	10	μF		
R <sub>f</sub>	External supply filter resistance	40	100	1K	Ω		
C <sub>f</sub>	External supply filter capacitance	1	10	40	μF		
R <sub>FILT</sub>	Sense resistor filter resistance	100	1K		Ω		
R <sub>ALERT</sub>	ALERT pin to VSS resistor		1M		Ω		
C <sub>L</sub>	REGOUT loading capacitance	1	4.7		μF		
C <sub>CAP</sub>	REGSRC, CAP1, CAP2, and CAP3 output capacitance	1			μF		
R <sub>TS</sub>	External thermistor nominal resistance (103AT) at 25°C	10K			Ω		
T <sub>OPR</sub>	Operating free-air temperature	–40		85	°C		

## 7.4 Thermal Information

Over-operating free-air temperature range (unless otherwise noted)

THERMAL METRIC <sup>(1)</sup>	TSSOP			UNIT
	BQ76920xy 20 PINS (PW)	BQ76930xy 30 PINS (DBT)	BQ76940xy 44 PINS (DBT)	
R <sub>θJA, High K</sub> Junction-to-ambient thermal resistance	93.7	86.5	70.1	°C/W
R <sub>θJC(top)</sub> Junction-to-case(top) thermal resistance	28.7	19.4	17.5	°C/W
R <sub>θJB</sub> Junction-to-board thermal resistance	44.6	41.3	33.9	°C/W
ψ <sub>JT</sub> Junction-to-top characterization parameter	1.3	0.5	0.5	°C/W
ψ <sub>JB</sub> Junction-to-board characterization parameter	44.1	40.6	33.4	°C/W
R <sub>θJC(bottom)</sub> Junction-to-case(bottom) thermal resistance	n/a	n/a	n/a	°C/W

(1) For more information about traditional and new thermal metrics, see the [Semiconductor and IC Package Thermal Metrics Application Report \(SPRA953\)](#).

## 7.5 Electrical Characteristics

Typical conditions are measured at 25°C with nominal BAT voltages of 18 V (BQ76920), 36 V (BQ76930), or 48 V (BQ76940) with V<sub>CELL</sub> = 4 V. Min and max values include full recommended operating condition temperature range from –40°C to +85°C. Certain characteristics may be shown at different voltage or temperature ranges, as clarified in the Test Condition sections.

PARAMETER		TEST CONDITION	MIN	TYP	MAX	UNIT
<b>SUPPLY CURRENTS</b>						
I <sub>DD</sub>	NORMAL mode: ADC off, CC off	Sum of ICC_BAT and ICC_REGSRC currents		40	60	μA
	NORMAL mode: ADC on, CC off			60	90	
	NORMAL mode: ADC off, CC on			110	165	
	NORMAL mode: ADC on, CC on			130	195	
I <sub>CC_BAT</sub>	NORMAL mode: ADC off	Into BAT pin		30	45	
	NORMAL mode: ADC on			50	75	
I <sub>CC_REGSRC</sub>	NORMAL mode: CC off	Into REGSRC pin		10	15	
	NORMAL mode: CC on			80	120	
I <sub>SHIP</sub>	SHIP/SHUTDOWN mode	Device in full shutdown, only VSTUP/BG and BOOT detector on		0.6	1.8	
<b>LEAKAGE AND OFFSET CURRENTS</b>						
d <sub>I<sub>NOM</sub></sub>	NORMAL mode supply current offset	Measured into VC5x (BQ76930, BQ76940) and VC10x (BQ76940)	–5	±2.5	5	μA
d <sub>I<sub>SHIP</sub></sub>	SHIP mode supply current offset		–1.0	±0.1	1.0	
d <sub>I<sub>ALERT</sub></sub>	Supply current when ALERT active	Measured into VC5x (BQ76930, BQ76940) or added to BAT (BQ76920)		15	25	
d <sub>I<sub>CELL</sub></sub>	Cell measurement input current	Measured into VC0–VC15 except VC5, VC10, VC15	–0.3	±0.1	0.3	
		Measured into VC5, VC10, VC15			0.5	
I <sub>LKG</sub>	Terminal input leakage				1	
<b>INTERNAL POWER CONTROL (STARTUP and SHUTDOWN)</b>						
V <sub>PORA</sub>	Analog POR threshold	V <sub>BAT</sub> rising. See <sup>(4)</sup> .	4		5	V
V <sub>SHUT</sub>	Shutdown voltage	V <sub>BAT</sub> falling. See <sup>(4)</sup> .			3.6	V
t <sub>I<sub>2C</sub>STARTUP</sub>	Time delay after boot signal on TS1 before I <sup>2</sup> C communications allowed	Delay after boot sequence when I <sup>2</sup> C communication is allowed		1		ms

## 7.5 Electrical Characteristics (continued)

Typical conditions are measured at 25°C with nominal BAT voltages of 18 V (BQ76920), 36 V (BQ76930), or 48 V (BQ76940) with  $V_{CELL} = 4$  V. Min and max values include full recommended operating condition temperature range from –40°C to +85°C. Certain characteristics may be shown at different voltage or temperature ranges, as clarified in the Test Condition sections.

PARAMETER		TEST CONDITION	MIN	TYP	MAX	UNIT
$t_{BOOTREADY}$	Device boot startup delay	Delay after boot signal when device has completed full boot-up sequence			10	ms
$T_{SHUTD}$	Thermal shutdown voltage			100	150	°C
<b>MEASUREMENT SCHEDULE</b>						
$t_{VCELL}$	Cell voltage measurement interval	BQ76920, BQ76930, BQ76940		250		ms
$t_{INDCELL}$	Individual cell measurement time	Per cell, balancing off		50		
		Per cell, balancing on		12.5		
$t_{CB\_RELAX}$	Cell balancing relaxation time before cell voltage measured			12.5		
$t_{TEMP\_DEC}$	Temperature measurement decimation time	Measurement duration for temperature reading		12.5		
$t_{BAT}$	Pack voltage calculation interval			250		
$t_{TEMP}$	Temperature measurement interval	Period of measurement of either TS1/TS2/TS3 or internal die temp		2		s
<b>14-BIT ADC FOR CELL VOLTAGE AND TEMPERATURE MEASUREMENT</b>						
$ADC_{RANGE}$	ADC measurement recommend operation range	$V_{CELL}$ measurements	2		5	V
		TS/Temp measurements	0.3		3	V
$ADC_{LSB}$	ADC LSB value			382		µV
ADC	ADC cell voltage accuracy at 25°C	$V_{CELL} = 3.6$ V – 4.3 V		±10		mV
		$V_{CELL} = 3.2$ V – 4.6 V		±15		
		$V_{CELL} = 2.0$ V – 5.0 V		±25		
	ADC cell voltage accuracy 0°C to 60°C	$V_{CELL} = 3.6$ V – 4.3 V		±20		
		$V_{CELL} = 3.2$ V – 4.6 V		±25		
		$V_{CELL} = 2.0$ V – 5.0 V		±35		
	ADC cell voltage accuracy –40°C to 85°C	$V_{CELL} = 3.6$ V – 4.3 V	–40		40	
		$V_{CELL} = 3.2$ V – 4.6 V	–40		40	
		$V_{CELL} = 2.0$ V – 5.0 V	–50		50	
<b>16-BIT CC FOR PACK CURRENT MEASUREMENT</b>						
$CC_{RANGE}$	CC input voltage range		–200		200	mV
$CC_{FSR}$	CC full scale range		–270		270	mV
$CC_{LSB}$	CC LSB value	CC running constantly		8.44		µV
$t_{CC\_READ}$	Conversion time	Single conversion		250		ms
$CC_{INL}$	Integral nonlinearity	16-bit, best fit over input voltage range ± 200 mV		± 2	± 40	LSB
$CC_{OFFSET}$	Offset error			± 1	± 3	LSB
$CC_{GAIN}$	Gain error	Over input voltage range		± 0.5%	± 1.5%	FSR
$CC_{GAINDRIFT}$	Gain error drift	Over input voltage range			150	PPM / °C
$CC_{RIN}$	Effective input resistance			2.5		MΩ
<b>THERMISTOR BIAS</b>						
$R_{TS}$	Pull-up resistance	$T_A = 25^\circ\text{C}$	9.85	10	10.15	kΩ
$R_{TSDRIFT}$	Pull-up resistance across temp	$T_A = -40^\circ\text{C}$ to 85°C	9.7		10.3	kΩ

## 7.5 Electrical Characteristics (continued)

Typical conditions are measured at 25°C with nominal BAT voltages of 18 V (BQ76920), 36 V (BQ76930), or 48 V (BQ76940) with  $V_{CELL} = 4$  V. Min and max values include full recommended operating condition temperature range from –40°C to +85°C. Certain characteristics may be shown at different voltage or temperature ranges, as clarified in the Test Condition sections.

PARAMETER		TEST CONDITION	MIN	TYP	MAX	UNIT
<b>DIETEMP</b>						
$V_{DIETEMP25}$	Die temperature voltage	$T_A = 25^\circ\text{C}$		1.20		V
$V_{DIETEMPDRIFT}$	Die temperature voltage drift			–4.2		mV/°C
<b>INTEGRATED HARDWARE PROTECTIONS</b>						
$OV_{RANGE}$	OV threshold range		0x2008		0x2FF8	ADC
$UV_{RANGE}$	UV threshold range		0x1000		0x1FF0	ADC
$OV_{UVSTEP}$	OV and UV threshold step size			16		LSB
$UV_{MINQUAL}$	UV minimum value to qualify	Below $UV_{MINQUAL}$ , the cell is shorted (unused)		0x0518		ADC
$OV_{DELAY}$	OV delay timer options	OV delay = 1 s	0.7	1	1.75	s
		OV delay = 2 s	1.6	2	2.75	
		OV delay = 4 s	3.5	4	5	
		OV delay = 8 s	7	8	10	
$UV_{DELAY}$	UV delay timer options	UV delay = 1 s	0.7	1	1.75	
		UV delay = 4 s	3.5	4	5	
		UV delay = 8 s	7	8	10	
		UV delay = 16 s	14	16	20	
$OCD_{RANGE}$	OCD threshold options	Measured across (SRP–SRN) <sup>(2)</sup>	8		100	mV
$OCD_{STEP}$	OCD threshold step size	RSNS = 0		2.78		mV
		RSNS = 1		5.56		mV
$OCD_{DELAY}$	OCD delay options	See Note <sup>(3)</sup>	8		1280	ms
$SCD_{RANGE}$	SCD threshold options	Measured across (SRP–SRN) <sup>(2)</sup>	22		200	mV
$SCD_{STEP}$	SCD threshold step size	RSNS = 0		11.1		mV
		RSNS = 1		22.2		mV
$SCD_{DELAY}$	SCD delay options		35	70	105	μs
			50	100	150	μs
			140	200	260	μs
			280	400	520	μs
$t_{PROTACC}$	Delay accuracy for OCD		–20%		20%	
$OC_{OFFSET}$	OCD and SCD voltage offset		–2.5		2.5	mV
$OC_{SCALEERR}$	OCD and SCD scale accuracy		–10%		10%	
<b>CHARGE AND DISCHARGE DRIVERS</b>						
$V_{FETON}$	CHG and DSG on	REGSRC ≥ 12 V with load resistance of 10 MΩ	10	12	14	V
		REGSRC < 12 V with load resistance of 10 MΩ	REGSRC – 2	REGSRC – 1	REGSRC	V
$t_{FET\_ON}$	CHG and DSG ON rise time	CHG/DSG driving an equivalent load capacitance of 10 nF, measured from 10% to 90% of $V_{FETON}$		200	250	μs
$t_{DSG\_OFF}$	DSG pull-down OFF fall time	DSG driving an equivalent load capacitance of 10 nF, measured from 90% to 10%		60	90	μs

## 7.5 Electrical Characteristics (continued)

Typical conditions are measured at 25°C with nominal BAT voltages of 18 V (BQ76920), 36 V (BQ76930), or 48 V (BQ76940) with  $V_{CELL} = 4$  V. Min and max values include full recommended operating condition temperature range from –40°C to +85°C. Certain characteristics may be shown at different voltage or temperature ranges, as clarified in the Test Condition sections.

PARAMETER		TEST CONDITION	MIN	TYP	MAX	UNIT
$R_{CHG\_OFF}$	CHG pull-down OFF resistance to VSS	When CHG disabled, CHG held at 12 V	750	1000	1250	k $\Omega$
$R_{DSG\_OFF}$	DSG pull-down OFF resistance to VSS	When DSG disabled, DSG held at 12 V	1.75	2.50	4.25	k $\Omega$
$V_{LOAD\_DETECT}$	Load detection threshold		0.4	0.7	1.0	V
$V_{CHG\_CLAMP}$	CHG clamp voltage	If the CHG pin externally pulled high (through PACK–, if load applied), 500- $\mu$ A max sink current into CHG pin. With CHG_ON bit cleared.	18	20	22	V
<b>ALERT PIN</b>						
$V_{ALERT\_OH}$	ALERT output voltage high	$I_{OL} = 1$ mA	REGOUT x 0.75			V
$V_{ALERT\_OL}$	ALERT output voltage low	Unloaded	REGOUT x 0.25			V
$V_{ALERT\_IH}$	ALERT input high	ALERT externally forced high when internally driven low. See note (1).	1		1.5	V
$R_{ALERT\_PD}$	ALERT pin weak pulldown resistance when driven low	Measured into ALERT pin with ALERT = REGOUT	0.8	2.5	8	M $\Omega$
<b>CELL BALANCING DRIVER</b>						
$R_{DSFET}$	Internal cell balancing driver resistance	$V_{CELL} = 3.6$ V	1	5	10	$\Omega$
$X_{BAL}$	Cell balancing duty cycle when enabled	Every 250 ms		70%		
<b>EXTERNAL REGULATOR</b>						
$V_{EXTLDO}$	External LDO voltage options	Nominal values, TI factory programmed, unloaded, across temp	2.45	2.50	2.55	V
			3.20	3.30	3.40	V
$V_{EXTLDO\_LN}$	Line regulation	REGSRC pin stepped from 6 to 25 V, with 10-mA load, in 100 $\mu$ s			100	mV
$V_{EXTLDO\_LD}$	Load regulation	$I_{REGOUT} = 0$ mA to 10 mA	–4%		4%	
$V_{EXTLDO\_DC}$	External LDO minimum voltage under DC load	REGOUT = 10-mA DC, 2.5-V version	2.4			V
		REGOUT = 20-mA DC, 2.5-V version	2.3			V
		REGOUT = 10-mA DC, 3.3-V version	3.15			V
		REGOUT = 20-mA DC, 3.3-V version	3.05			V
$I_{EXTLDO\_LIMIT}$	External LDO current limit	REGOUT = 0 V	30	38	45	mA
<b>BOOT DETECTOR</b>						
$V_{BOOT}$	Boot threshold voltage	Measured at TS1 pin with device in SHIP mode. Below MIN, the device does not boot up. Above MAX, the device boots up.	300		1000	mV
$t_{BOOT\_max}$	Boot threshold application time	Measured at TS1 pin. Below MIN, the device does not boot up. Above MAX, the device boots up.	10		2000	$\mu$ s

- (1) MIN specifies the threshold below which the device will never register that an external alert has occurred. MAX specifies the minimum threshold above which the device will always register that an external alert has occurred.
- (2) Values indicate nominal thresholds only. For min and max variation, apply  $OC_{OFFSET}$  and  $OC_{SCALERR}$ .
- (3) Values indicate nominal thresholds only. For min and max variation, apply  $t_{PROTACC}$ .
- (4) Measured at each  $V_{BAT}$

## 7.6 Timing Requirements

I <sup>2</sup> C COMPATIBLE INTERFACE		MIN	TYP	MAX	UNIT
V <sub>IL</sub>	Input low logic threshold			REGOUT x 0.25	V
V <sub>IH</sub>	Input high logic threshold	REGOUT x 0.75			V
V <sub>OL</sub>	Output low logic drive			0.20	V
t <sub>f</sub>	SCL, SDA fall time			0.40	
V <sub>OH</sub>	Output high logic drive (not applicable due to open-drain outputs)	N/A		N/A	V
t <sub>HIGH</sub>	SCL pulse width high	4.0			μs
t <sub>LOW</sub>	SCL pulse width low	4.7			μs
t <sub>SU,STA</sub>	Setup time for START condition	4.7			μs
t <sub>HD,STA</sub>	START condition hold time after which first clock pulse is generated	4.0			μs
t <sub>SU,DAT</sub>	Data setup time	250			ns
t <sub>HD,DAT</sub>	Data hold time	0			μs
t <sub>SU,STO</sub>	Setup time for STOP condition	4.0			μs
t <sub>BUF</sub>	Time the bus must be free before new transmission can start	4.7			μs
t <sub>VD,DAT</sub>	Clock low to data out valid			900	ns
t <sub>HD,DAT</sub>	Data out hold time after clock low	0			ns
f <sub>SCL</sub>	Clock frequency	0		100	kHz

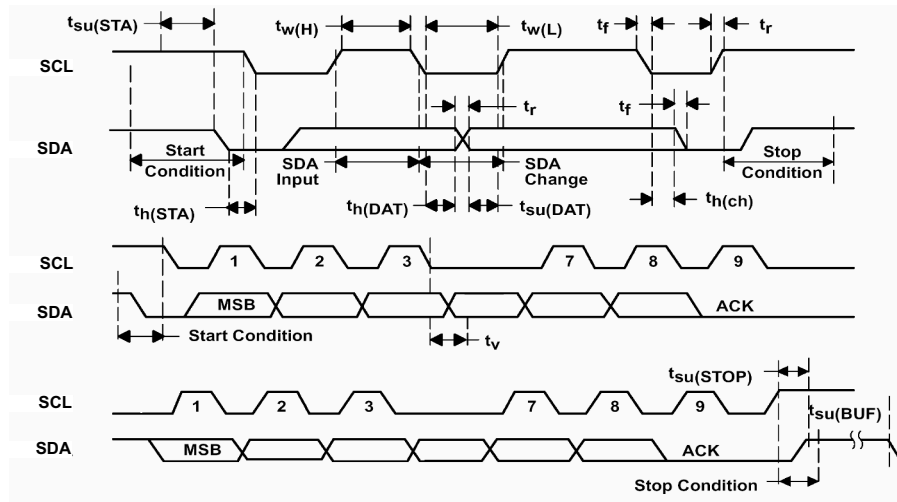
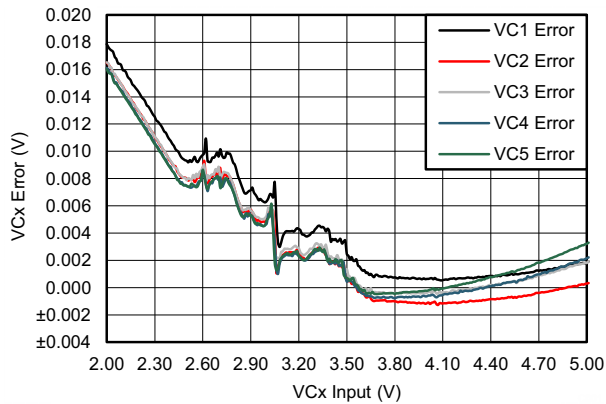
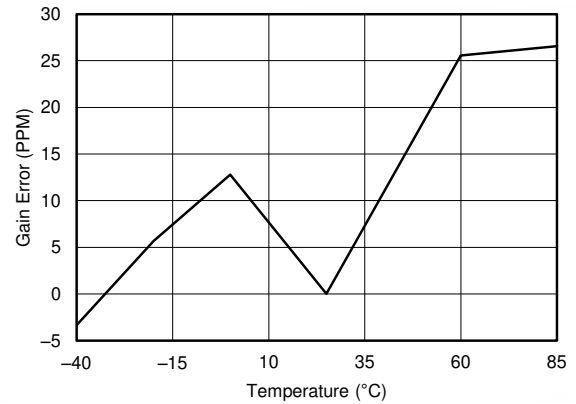

Figure 7-1. I<sup>2</sup>C Timing

## 7.7 Typical Characteristics



**Figure 7-2. BQ76930 VCx Error Across Input Range at 25°C with VIN at 3.6 V**



**Figure 7-3. Coulomb Counter Gain Error Temperature Drift (from -0.2 V to 0.2 V)**

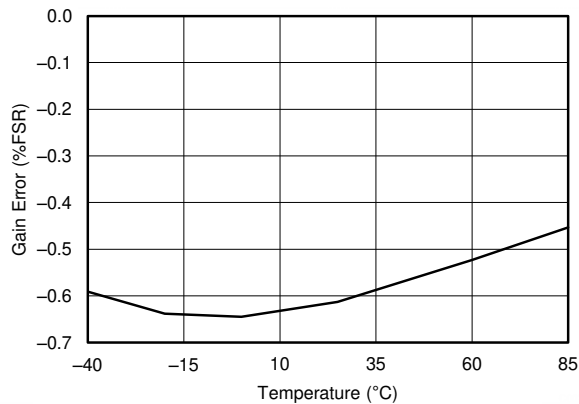

**Figure 7-4. Coulomb Counter Gain Error (from -0.2 V to 0.2 V)**

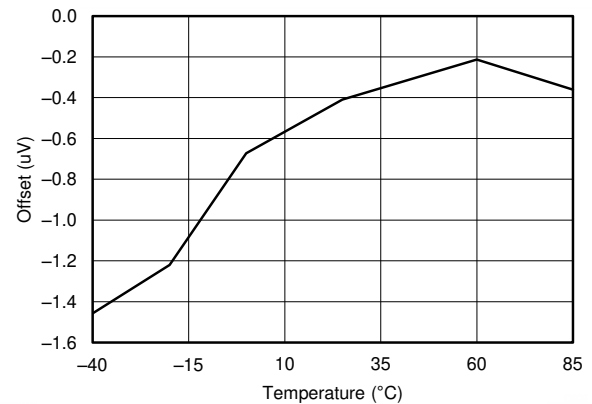

**Figure 7-5. Coulomb Counter Offset**

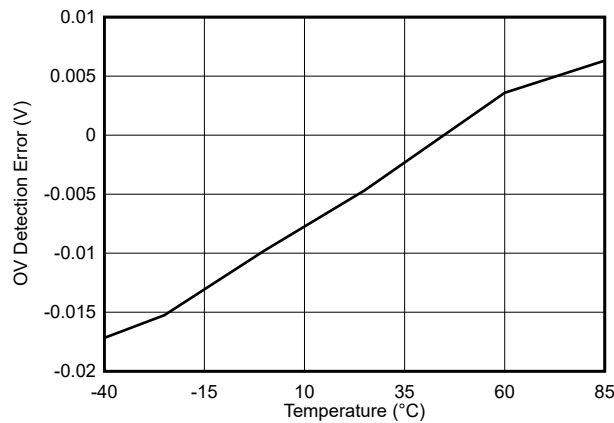

**Figure 7-6. OV Protection Detection Error (0xFF Setting)**

## 8 Detailed Description

### 8.1 Overview

In the BQ769x0 family of analog front-end (AFE) devices, the BQ76920 device supports up to 5-series cells, the BQ76930 device supports up to 10-series cells, and the BQ76940 device supports up to 15-series cells. Through I<sup>2</sup>C, a host controller can use the BQ769x0 to implement battery pack management functions, such as monitoring (cell voltages, pack current, pack temperatures), protection (controlling charge/discharge FETs), and balancing. Integrated A/D converters enable a purely digital readout of critical system parameters including cell voltages and internal or external temperature, with calibration handled in TI's manufacturing process. For an additional degree of pack reliability, the BQ769x0 includes hardware protections for voltage (OV, UV) and current (OCD, SCD).

The BQ769x0 provides two low-side FET drivers, charge (CHG) and discharge (DSG), which may be used to directly manipulate low-side power NCH FETs, or as signals that control an external circuit that enables high-side PCH or NCH FETs. A dedicated ALERT input/output pin serves as an interrupt signal to the host microcontroller, quickly informing the microcontroller of an updated status in the AFE. This may include a fault event or that a coulomb counter sample is available for reading. An available ALERT pin may also be driven externally by a secondary protector to provide a redundant means of disabling the CHG and DSG signals and higher system visibility.

### 8.2 Functional Block Diagram

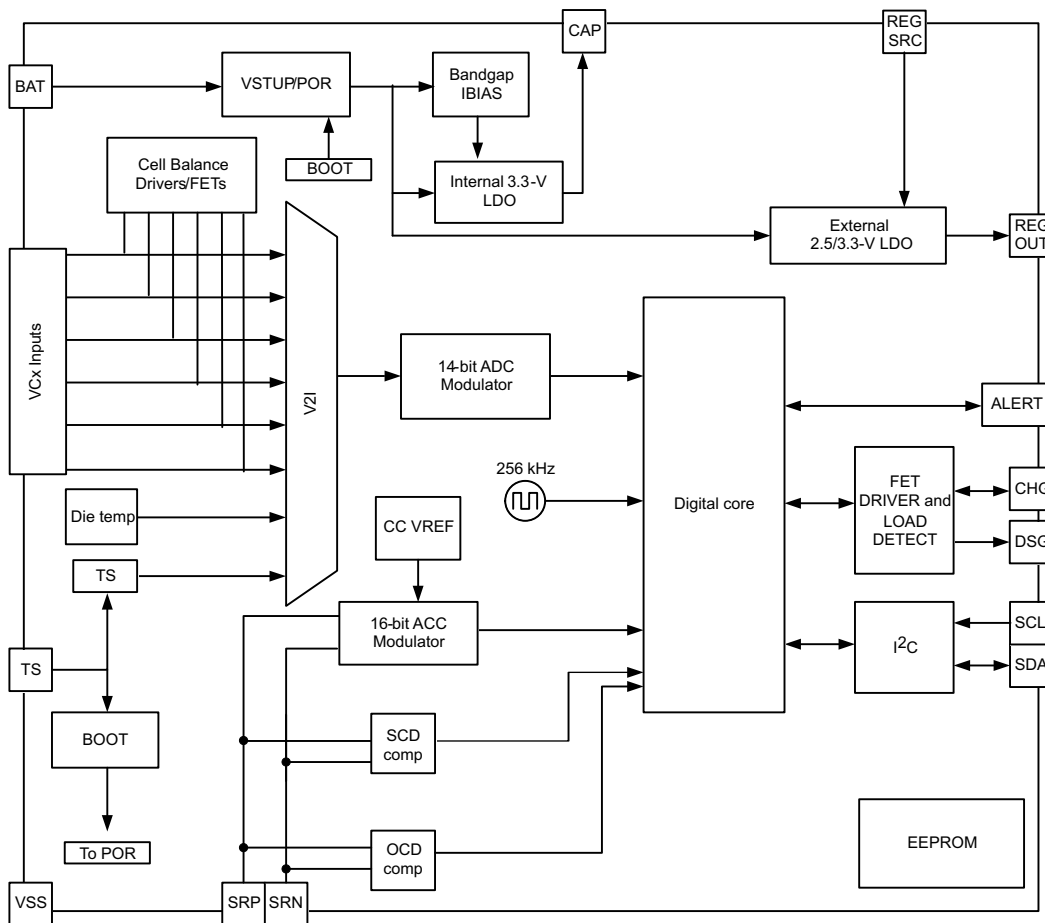

Copyright © 2016, Texas Instruments Incorporated

## 8.3 Feature Description

### 8.3.1 Subsystems

BQ769x0 consists of three major subsystems: Measurement, Protection, and Control. These work together to ensure that the fundamental battery pack parameters—voltage, current and temperature—are accurately captured and easily available to a host controller, while ensuring a baseline or secondary level of hardware protection in the event that a host controller is unable or unavailable to manage certain fault conditions.

---

#### Note

The BQ769x0 is intended to serve as an analog front-end (AFE) as part of a chipset system solution: A companion microcontroller is required to oversee and control this AFE.

---

- The Measurement subsystem's core responsibility is to digitize the cell voltages, pack current (integrated into a passed charge calculation), external thermistor temperature, and internal die temperature. It also performs an automatic calculation of the total battery stack voltage, by simply adding up all measured cell voltages.
- The Protection subsystem provides a baseline or secondary level of hardware protections to better support a battery pack's FMEA requirements in the event of a loss of host control or simply if a host is unable to respond to a certain fault event in time. Integrated protections include pack-level faults such as OV, UV, OCD, SCD, detection of an external secondary protector fault, and internal logic "watchdog"-style device fault (XREADY). Protection events will trigger toggling of the ALERT pin, as well as automatic disabling of the DSG or CHG FET driver (depending on the fault). Recovery from a fault event must be handled by the host microcontroller.
- The Control subsystem implements a suite of useful pack features, including direct low-side NCH FET drivers, cell balancing drivers, the ALERT digital output, an external LDO and more.

The following sections describe each subsystem in greater detail, as well as explaining the various power states that are available.

#### 8.3.1.1 Measurement Subsystem Overview

The monitoring subsystem ensures that all cell voltages, temperatures, and pack current may be easily measured by the host. All ADCs are trimmed by TI.

ADC and CC data are always returned as atomic values if both high and low registers are read in the same transaction (using address auto-increment).

##### 8.3.1.1.1 Data Transfer to the Host Controller

The BQ769x0 has a fully digital interface: All information is transferred through I<sup>2</sup>C, simply by reading and/or writing to the appropriate register(s) storing the relevant data. Block reads and writes, buffered by an 8-bit CRC code per byte, ensure a fast and robust transmission of data.

##### 8.3.1.1.2 14-Bit ADC

Each BQ769x0 device measures cell voltages and temperatures using a 14-bit ADC. This ADC measures all differential cell voltages, thermistors and/or die temperature with a nominal full-scale unsigned range of 0–6.275 V and LSB of 382  $\mu$ V.

To enable the ADC, the *[ADC\_EN]* bit in the SYS\_CTRL1 register must be set. This bit is set automatically whenever the device enters NORMAL mode. When enabled, the ADC ensures that the integrated OV and UV protections are functional.

For each contiguous set of five cells (VC1 to VC5, VC6 to VC10), when no cells in that particular set are being balanced, each cell is measured over a 50-ms decimation window and a complete update is available every 250 ms. In the BQ76930 and BQ76940, every set of five cells above the primary five cells is measured in parallel. The 50-ms decimation greatly assists with removing the aliasing effects present in a noisy motor environment.

When any cells in a contiguous set of 5 cells are being balanced, those affected cells are measured in a reduced 12.5-ms decimation period, to allow the cell balancing to function properly without affecting the integrated OV and UV protections. Since cell balancing is typically only performed during pack charge or idle periods, the

shortened decimation periods should not impact accuracy as the system noise during these times is greatly reduced. This reduced decimation period is only applied to sets where one of the cells is being balanced. The following summarizes this for the BQ76920–BQ76940 devices:

- VC1 to VC5 measurements are each taken in a 50-ms decimation period when all bits in CELLBAL1 register are 0, and a 12.5-ms decimation period when any bits in CELLBAL1 register are 1.
- VC6 to VC10 measurements are each taken in a 50-ms decimation period when all bits in CELLBAL2 register are 0, and a 12.5-ms decimation period when any bits in CELLBAL2 register are 1.
- VC11 to VC15 measurements are each taken in a 50-ms decimation period when all bits in CELLBAL3 register are 0, and a 12.5-ms decimation period when any bits in CELLBAL3 register are 1.
- Total update interval is 250 ms.

Each differential cell input is factory-trimmed for gain or offset, such that the resulting reading through I<sup>2</sup>C is always consistent from part-to-part and requires no additional calibration or correction factor application.

The ADC is required to be enabled in order for the integrated OV and UV protections to be operating.

The following shows how to convert the 14-bit ADC reading into an analog voltage. Each device is factory calibrated, with a GAIN and OFFSET stored into EEPROM.

The ADC transfer function is a linear equation defined as follows:

$$V(\text{cell}) = \text{GAIN} \times \text{ADC}(\text{cell}) + \text{OFFSET} \quad (1)$$

GAIN is stored in units of  $\mu\text{V}/\text{LSB}$ , while OFFSET is stored in mV units.

Some example cell voltage calculations are provided in the table below. For illustration purposes, the example uses a hypothetical GAIN of 380  $\mu\text{V}/\text{LSB}$  (ADCGAIN<4:0> = 0x0F) and OFFSET of 30 mV (ADCOFFSET<7:0> = 0x1E).

14-Bit ADC Result	ADC Result in Decimal	GAIN ( $\mu\text{V}/\text{LSB}$ )	OFFSET (mV)	Cell Voltage (mV)
0x1800	6144	380	30	2365
0x1F10	7952	380	30	3052

#### Note

When entering NORMAL mode from SHIP mode, please allow for the following times before reading out initial cell voltage data:

BQ76920: 250 ms

BQ76930: 400 ms

BQ76940: 800 ms

### 8.3.1.1.2.1 Optional Real-Time Calibration Using the Host Microcontroller

The performance of the cell voltage values measured by the 14-bit ADC has a factory-calibrated accuracy, as follows:

- +/- 10 mV TYP, +/- 40 mV MIN and MAX from 3.6 to 4.3 V,
- +/- 15 mV TYP, +/- 40 mV MIN and MAX from 3.2 to 4.6 V, and
- +/- 50 mV MIN and MAX from 2.0 to 5.0 V

While this is suitable for the majority of pack protection and basic monitoring applications the BQ769x0 AFE family is intended to support, certain systems may require a higher accuracy performance.

To achieve this, use an available ADC channel and general purpose output terminal on the host microcontroller paired with the BQ769x0. A simple external circuit consisting of two precision resistors and a small-signal FET is activated by the host microcontroller to determine the total stack voltage,  $V_{STACK}$ . This is then compared against the sum of the individual cell voltages as measured by the internal ADC of the BQ769x0. The resulting transfer function coefficient,  $GAIN_2$ , is simply applied to each cell voltage ADC value for improved accuracy.

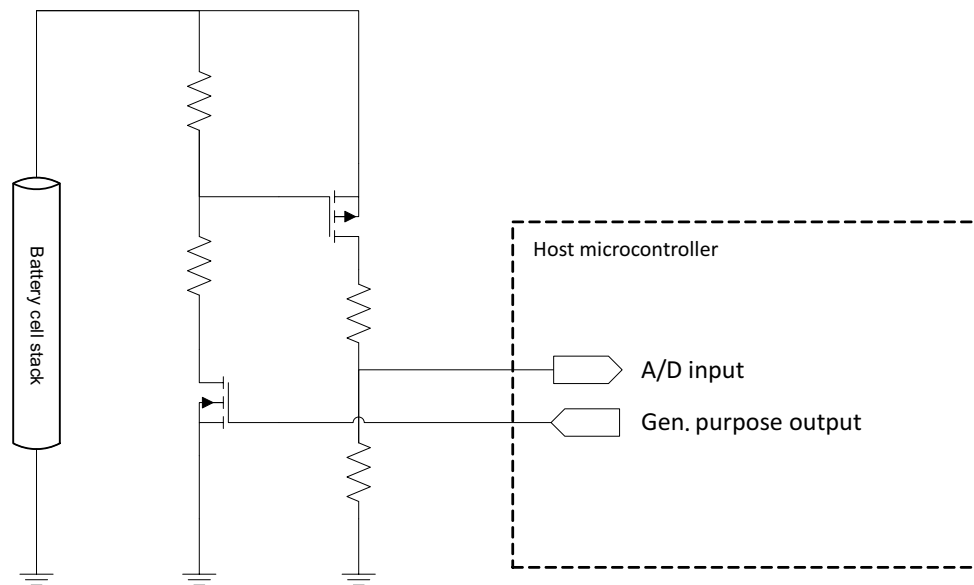

**Figure 8-1. External Real-Time Calibration Circuit to Host Microcontroller**

The process is as follows:

1. Periodically measure  $V_{STACK}$ .
  - a.  $V_{STACK} = V_{AD} \times (R1 + R2) / R1$
2. Read out all  $V_{CELL}$  ADC readings from the BQ769x0 and apply the standard GAIN and OFFSET values stored in the BQ769x0.
  - a.  $V(1) = GAIN \times ADC_1 + OFFSET$ ,  $V(2) = GAIN \times ADC_2 + OFFSET$ , and so on
3. Sum up all  $V_{CELL}$  values,  $V_{SUM}$ .
  - a.  $V_{SUM} = V(1) + V(2) + V(3) \dots$
4. Calculate  $GAIN_2$ .
  - a.  $GAIN_2 = V_{STACK} / V_{SUM}$

As a general recommendation, a new  $GAIN_2$  function should be generated when the cell voltages increase or decrease by more than 100 mV. With  $GAIN_2$ , each cell voltage calculation becomes:

$$V(\text{cell}) = GAIN_2 \times (GAIN \times \text{ADC}(\text{cell}) + \text{OFFSET}) \quad (2)$$

For systems that do not require this additional in-use calibration function,  $GAIN_2$  is simply "1".

### 8.3.1.1.3 16-Bit CC

A 16-bit integrating ADC, commonly referred to as the coulomb counter (CC), provides measurements of accumulated charge across the current sense resistor. The integration period for this reading is 250 ms.

The CC may be operated in one of two modes: ALWAYS ON and 1-SHOT.

- In ALWAYS ON mode, the CC runs at 100%, gathering a fresh reading every 250 ms. The conclusion of each reading sets the CC\_READY bit, which toggles the ALERT pin high to inform the microcontroller that a new reading is available. To enable Always On mode, set  $[CC\_EN] = 1$ .
- In 1-SHOT mode, the CC performs a single 250-ms reading, and similarly sets the CC\_READY bit when completed. This mode is intended for non-gauging usages, where the host simply desires to check the pack current.

To enable a 1-SHOT reading, ensure  $[CC\_EN] = 0$  and set  $[CC\_ONESHOT] = 1$ .

The fullscale range of the CC is  $\pm 270$  mV, with a max recommended input range of  $\pm 200$  mV, thus yielding an LSB of approximately 8.44  $\mu$ V.

The following equation shows how to convert the 16-bit CC reading into an analog voltage if no board-level calibration is performed:

$$\text{CC Reading (in } \mu\text{V)} = [\text{16-bit 2's Complement Value}] \times (8.44 \mu\text{V/LSB}) \quad (3)$$

16-Bit CC Result	ADC Result in Decimal	CC Reading (in $\mu$ V)
0x0001	1	8.44
0x2710	10000	84,400
0x7D00	32000	270,080
0x8300	-32000	-270,080
0xC350	-15536	-131,123.84
0xFFFF	-1	-8.44

### 8.3.1.1.4 External Thermistor

One (BQ76920), two (BQ76930), or three (BQ76940) 10-k $\Omega$  NTC 103AT thermistors may be measured by the device. These are measured by applying a factory-trimmed internal 10-k pull-up resistance to an internal regulator value of nominally 3.3 V, the result of which can be read out from the TSx (TS1, TS2, TS3) registers.

To select thermistor measurement mode, set  $[TEMP\_SEL] = 1$ .

Thermistor TS1 is connected between TS1 and VSS; TS2 is connected between TS2 and VC5x (BQ76930 and BQ76940 only); and TS3 is connected between TS3 and VC10x (BQ76940 only). These thermistors may be placed in various areas in the battery pack to measure such things as localized cell temperature, FET heating, and so forth.

The thermistor impedance may be calculated using the 14-bit ADC reading in the TS1, TS2, and TS3 registers and 10-k internal pull-up resistance as follows:

The following equations show how to use the 14-bit ADC readings in TS1, TS2, and TS3 to determine the resistance of the external 103AT thermistor:

$$V_{TSX} = (\text{ADC in Decimal}) \times 382 \mu\text{V/LSB} \quad (4)$$

$$R_{TS} = (10,000 \times V_{TSX}) \div (3.3 - V_{TSX}) \quad (5)$$

To convert the thermistor resistance into temperature, please refer to the thermistor component manufacturer's data sheet.

### 8.3.1.1.5 Die Temperature Monitor

---

#### Note

When switching between external and internal temperature monitoring, a 2-s latency may be incurred due to the natural scheduler update interval.

---

A die temperature block generates a voltage that is proportional to the die temperature, and provides a way of reducing component count if pack thermistors are not used or ensuring that the die power dissipation requirements are observed. The die is measured using the same on-board 14-bit ADC as the cell voltages.

To select internal die temperature measurement mode, set  $[TEMP\_SEL] = 0$ .

For BQ76930 and BQ76940, multiple die temperature measurements are available. These are stored in TS2 and TS3.

To convert a DIETEMP reading into temperature, refer to the following equation box. If more accurate temperature readings are needed from DIETEMP, the DIETEMP at room temperature value should be stored during production calibration.

The following equation shows how to use the 14-bit ADC readings in TS1, TS2, and TS3 when  $[TEMPSEL] = 0$  to determine the internal die temperature:

$$V_{25} = 1.200 \text{ V (nominal)} \quad (6)$$

$$V_{TSX} = (\text{ADC in Decimal}) \times 382 \mu\text{V/LSB} \quad (7)$$

$$TEMP_{DIE} = 25^\circ - ((V_{TSX} - V_{25}) \div 0.0042) \quad (8)$$

### 8.3.1.1.6 16-Bit Pack Voltage

Once converted to digital form, each cell voltage is added up and the summation result stored in the BAT registers. The sum is divided by 4 so that the result of summing 15 cells fits in the 16-bit value. This 16-bit value has a nominal LSB of 1.532 mV.

The following shows how to convert the 16-bit pack voltage ADC reading into an analog voltage. This value also uses the GAIN and OFFSET stored into EEPROM.

The ADC transfer function is a linear equation defined as follows:

$$V_{(BAT)} = 4 \times \text{GAIN} \times \text{ADC}(\text{cell}) + (\#\text{Cells} \times \text{OFFSET}) \quad (9)$$

GAIN is stored in units of  $\mu\text{V/LSB}$ , while OFFSET is stored in mV units.

### 8.3.1.1.7 System Scheduler

A master scheduler oversees the monitoring intervals, creating a full update every 250 ms. Temperature measurements are taken every 2 seconds. Pack voltage is calculated every 250 ms. More information on the System Scheduler can be found in the [Embedded Scheduler in Cell Battery Monitor of the BQ769x0](#) application report.

### 8.3.1.2 Protection Subsystem

#### 8.3.1.2.1 Integrated Hardware Protections

Integrated hardware protections are provided as an extra degree of safety and are meant to supplement the standard protection feature set that would be incorporated into the host controller firmware. They should not be used as the sole means of protecting a battery pack, but are useful for FMEA purposes; for example, in the event that a host microcontroller is unable to react to any of the below protection situations. All hardware protection thresholds and delays should be loaded into the AFE by the host microcontroller during system startup. The AFE will also default to predefined threshold and delay settings, in case the host microcontroller is unable to or does not wish to program the protection settings.

Overcurrent in Discharge (OCD) and Short Circuit in Discharge (SCD) are implemented using sampled analog comparators that run at 32 kHz, and that continuously monitor the voltage across (SRP–SRN) while the device is in NORMAL mode. Upon detection of a voltage that exceeds the programmed OCD or SCD threshold, a counter begins to count up to a programmed delay setting. If the counter reaches its target value, the SYS\_STAT register is updated to indicate the fault condition, the FET state(s) are updated as shown in [Table 8-1](#), and the ALERT pin is driven high to interrupt the host.

The protection fault threshold and delay settings for OCD and SCD protections are configured through the PROTECT1 and PROTECT2 registers. See [Section 8.5](#) for details about supported values.

Overvoltage (OV) and undervoltage (UV) protections are handled digitally, by comparing the cell voltage readings against the 8-bit programmed thresholds in the OV and UV registers.

The OV threshold is stored in the OV\_TRIP register and is a direct mapping of 8 bits of the 14-bit ADC reading, with the upper 2 MSB preset to “10” and the lower 4 LSB preset to “1000”. In other words, the corresponding OV trip level is mapped to “10-XXXX-XXXX–1000”. The programmable range of OV thresholds is approximately 3.15 to 4.7 V, but this is subject to variation due to the (GAIN, OFFSET) linear equation used to map the ADC values.

The UV threshold is stored in the UV\_TRIP register and is a direct mapping of 8 bits of the 14-bit ADC reading, with the upper 2 MSB preset to “01” and lower 4 LSB preset to “0000”. In other words, the corresponding UV trip level is mapped to “01-XXXX-XXXX–0000”. The programmable range of UV thresholds is approximately 1.58 to 3.1 V, but this is subject to variation due to the (GAIN, OFFSET) linear equation used to map the ADC values.

Protection	Upper 2 MSB	Middle 8 Bits	Lower 4 LSB
OV	10	Set in OV_TRIP Register	1000
UV	01	Set in UV_TRIP Register	0000

#### Note

To support flexible cell configurations within BQ76920, BQ76930, and BQ76940, UV is ignored on any cells that have a reading under  $UV_{MINQUAL}$ . This allows cell pins to be shorted in implementations where not all cells are needed (for example, 6-series cells using the BQ76930).

Default protection thresholds and delays are shown in the register description at the end of this data sheet. These are loaded into the digital register (RAM) of the device when the device enters NORMAL mode. These RAM values may then be overwritten by the host controller to any other values, which they will retain until a POR event. It is recommended that the host controller reload these values during its standard power-up and/or reinitialization sequence.

To calculate the correct OV\_TRIP and UV\_TRIP register values for a device, use the following procedure:

- Determine desired OV.
- Read out  $[ADCGAIN]$  and  $[ADCOFFSET]$  from their corresponding registers. Note that ADCGAIN is stored in units of  $\mu\text{V}/\text{LSB}$ , while ADCOFFSET is stored in mV.
- Calculate the full 14-bit ADC value needed to meet the desired OV and UV trip thresholds as follows:
  - $OV\_TRIP\_FULL = (OV - ADCOFFSET) \div ADCGAIN$
  - $UV\_TRIP\_FULL = (UV - ADCOFFSET) \div ADCGAIN$
- Remove the upper 2 MSB and lower 4 LSB from the full 14-bit value, retaining only the remaining middle 8 bits. This can be done by shifting the OV\_TRIP\_FULL and UV\_TRIP\_FULL binary values 4 bits to the right and removing the upper 2 MSB.
- Write OV\_TRIP and UV\_TRIP to their corresponding registers.

Both OV and UV protections require the ADC to be enabled. Ensure that the  $[ADC\_EN]$  bit is set to 1 if OV and UV protections are needed.

### 8.3.1.2.2 Reduced Test Time

A special debug and test configuration bit is provided in the SYS\_CTRL2 register, called *[DELAY\_DIS]*. Setting *[DELAY\_DIS]* bypasses the OV/UV protection fault timers and allows a fault condition to be registered within 200 ms after application of such a fault condition.

### 8.3.1.3 Control Subsystem

#### 8.3.1.3.1 FET Driving (CHG AND DSG)

Each BQ769x0 device provides two low-side FET drivers, CHG and DSG, which control NCH power FETs or may be used as a signal to enable various other circuits such as a high-side NCH charge pump circuit.

Both DSG and CHG drivers have a fast pull-up to nominally 12 V when enabled. DSG uses a fast pull-down to VSS when disabled, while CHG utilizes a high impedance (nominally 1 MΩ) pull-down path when disabled.

An additional internal clamp circuit ensures that the CHG pin does not exceed a maximum of 20 V.

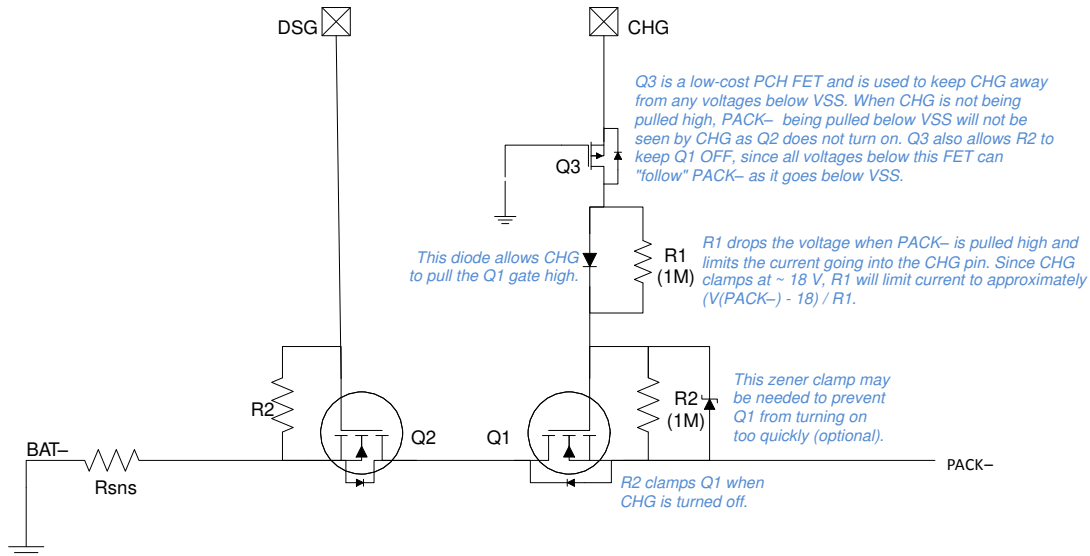

Figure 8-2. CHG and DSG FET Circuit

The power path for the CHG and DSG pull-up circuit originates from the REGSRC pin, instead of BAT.

To enable the CHG fet, set the *[CHG\_ON]* register bit to 1; to disable, set *[CHG\_ON]* = 0. The discharge FET may be similarly controlled through the *[DSG\_ON]* register bit.

Certain fault conditions or power state transitions will clear the state of the CHG/DSG FET controls. Table 8-1 shows what action, if any, to take to *[CHG\_ON]* and *[DSG\_ON]* in response to various system events:

#### 8.3.1.3.1.1 High-Side FET Driving

The BQ769x0 battery monitors provide low-side FET drivers that work well for many systems. For some systems, high-side FETs may also be beneficial. High-side FETs enable continuous communication between a host controller and the monitor, regardless of whether the FETs are on or off. This allows the controller to read critical pack parameters despite safety faults, enabling the system to access pack conditions before allowing normal operations to resume. The BQ769200 high-side N-channel FET driver can be used with the BQ769x0 monitor in systems where high-side FETs are needed. See Figure 9-4.

Table 8-1. CHG, DSG Response Under Various System Events

EVENT	<i>[CHG_ON]</i>	<i>[DSG_ON]</i>
OV Fault	Set to 0	—
UV Fault	—	Set to 0
OCD Fault	—	Set to 0
SCD Fault	—	Set to 0

**Table 8-1. CHG, DSG Response Under Various System Events (continued)**

EVENT	[CHG_ON]	[DSG_ON]
ALERT Override	Set to 0	Set to 0
DEVICE_XREADY is set	Set to 0	Set to 0
Enter SHIP mode from NORMAL	Set to 0	Set to 0

**Note**

The host microcontroller must initiate all protection recovery. To resume FET operation after a fault condition, the host microcontroller must first clear the corresponding status bit in the SYS\_STAT register, which will clear the ALERT pin, and then manually reenables the CHG and/or DSG bit. Certain faults, such as OV or UV, may immediately retoggle if such a condition still persists. Refer to [Table 8-3](#) for details on clearing status bits.

There are no conditions under which the BQ769x0 automatically sets either [CHG\_ON] or [DSG\_ON] to 1.

**8.3.1.3.2 Load Detection**

A load detection circuit is present on the CHG pin and activated whenever the CHG FET is disabled ([CHG\_ON] = 0). This circuit detects if the CHG pin is externally pulled high when the high impedance (approximately 1 MΩ) pull-down path should actually be holding the CHG pin to VSS, and is useful for determining if the PACK– pin (outside of the AFE) is being held at a high voltage—for example, if the load is present while the power FETs are off. The state of the load detection circuit is read from the [LOAD\_PRESENT] bit of the SYS\_CTRL1 register.

After an OCD or SCD fault has occurred, the DSG FET will be disabled ([DSG\_ON] cleared), and the CHG FET must similarly be explicitly disabled to activate the load detection circuit. The host microcontroller may periodically poll the [LOAD\_PRESENT] bit to determine the state of the PACK– pin and determine when the load is removed ([LOAD\_PRESENT] = 0).

**8.3.1.3.3 Cell Balancing**

Both internal and external passive cell balancing options are fully supported by the BQ76920, while external cell balancing is recommended for BQ76930 and BQ76940. It is left to the host controller to determine the exact balancing algorithm to be used in any given system. Each BQ769x0 device provides the cell voltages and balancing drivers to enable this. If using the internal cell balance drivers, up to 50 mA may be balanced per cell. If using external cell balancing, much higher balancing currents may be employed.

To activate a particular cell balancing channel, simply set the corresponding bit for that cell in the CELLBAL1, CELLBAL2, or CELLBAL3 register. For example, VC1–VC0 is enabled by setting [CB1], while VC12–VC11 is set through [CB12].

Multiple cells may be simultaneously balanced. It is left to the user's discretion to determine the ideal number of cells to concurrently balance. Adjacent cells should not be balanced simultaneously. This may cause cell pins to exceed their absolute maximum conditions and is also not recommended for external balancing implementations. Additionally, if internal balancing is used, care should be taken to avoid exceeding package power dissipation ratings.

**Note**

The host controller must ensure that no two adjacent cells are balanced simultaneously within each set of the following:

- VC1–VC5
- VC6–VC10
- VC11–VC15

The total duty cycle devoted to balancing is approximately 70% per 250 ms. This is because a portion of the 250 ms is allotted for normal cell voltage measurements through the ADC.

If  $[ADC\_EN] = 1$ , OV and UV protections are not affected by cell balancing, since the cell balancing is temporarily suspended for a small slice of time every 250 ms during which the cell voltage readings are taken. This ensures that the OV and UV protections do not accidentally trigger, or miss an actual OV/UV condition on the cells while balancing is enabled.

---

#### Note

All cell balancing control bits in CELLBAL1, CELLBAL2, and CELLBAL3 are automatically cleared under the following events, and must be explicitly rewritten by the host microcontroller following clearing of the event:

- DEVICE\_XREADY is set
  - Enters NORMAL mode from SHIP mode
- 

#### 8.3.1.3.4 Alert

The ALERT pin serves as an active high digital interrupt signal that can be connected to a GPIO port of the host microcontroller. This signal is an OR of all bits in the SYS\_STAT register.

In order to clear the ALERT signal, the source bit in the SYS\_STAT register must first be cleared by writing a “1” to that bit. This will cause an automatic clear of the ALERT pin once all bits are cleared.

The ALERT pin may also be driven by an external source; for example, the pack may include a secondary overvoltage protector IC. When the ALERT pin is forced high externally while low, the device will recognize this as an OVRD\_ALERT fault and set the  $[OVRD\_ALERT]$  bit. This triggers automatic disabling of both CHG and DSG FET drivers. The device cannot recognize the ALERT signal input high when it is already forcing the ALERT signal high from another condition.

The ALERT pin has no internal debounce support so care should be taken to protect the pin from noise or other parasitic transients.

---

#### Note

It is highly recommended to place an external 500 k $\Omega$ –1 M $\Omega$  pull-down resistor from ALERT to VSS as close to the IC as possible. Additional recommendations are:

- a) To keep all traces between the IC and components connected to the ALERT pin very short.
  - b) To include a guard ring around the components connected to the ALERT pin and the pin itself.
- 

#### 8.3.1.3.5 Output LDO

An adjustable output voltage regulator LDO is provided as a simple way to provide power to additional components in the battery pack, such as the host microcontroller or LEDs. The LDO is configured in EEPROM by TI during the production test process, and can support 2.5-V or 3.3-V options.

A cascode small-signal FET must be added in the external path between BAT and REGSRC with the BQ76930 and BQ76940. This helps drop most of the power dissipation outside of the package and cuts down on package power dissipation.

#### 8.3.1.4 Communications Subsystem

The AFE implements a standard 100-kHz I<sup>2</sup>C interface and acts as a slave device. The I<sup>2</sup>C device address is 7-bits and is factory programmed. Consult the Device Comparison Table (Section 5) of this data sheet for more information.

A write transaction is shown in Figure 8-3. Block writes are allowed by sending additional data bytes before the Stop. The I<sup>2</sup>C block will auto-increment the register address after each data byte.

When enabled, the CRC is calculated as follows:

- In a single-byte write transaction, the CRC is calculated over the slave address, register address, and data.

- In a block write transaction, the CRC for the first data byte is calculated over the slave address, register address, and data. The CRC for subsequent data bytes is calculated over the data byte only.

The CRC polynomial is  $x^8 + x^2 + x + 1$ , and the initial value is 0.

When the slave detects a bad CRC, the I<sup>2</sup>C slave will NACK the CRC, which causes the I<sup>2</sup>C slave to go to an idle state.

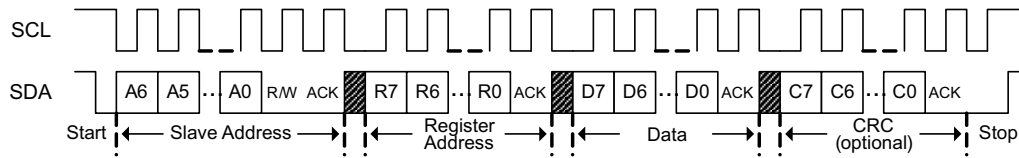

**Figure 8-3. I<sup>2</sup>C Write**

Figure 8-4 shows a read transaction using a Repeated Start.

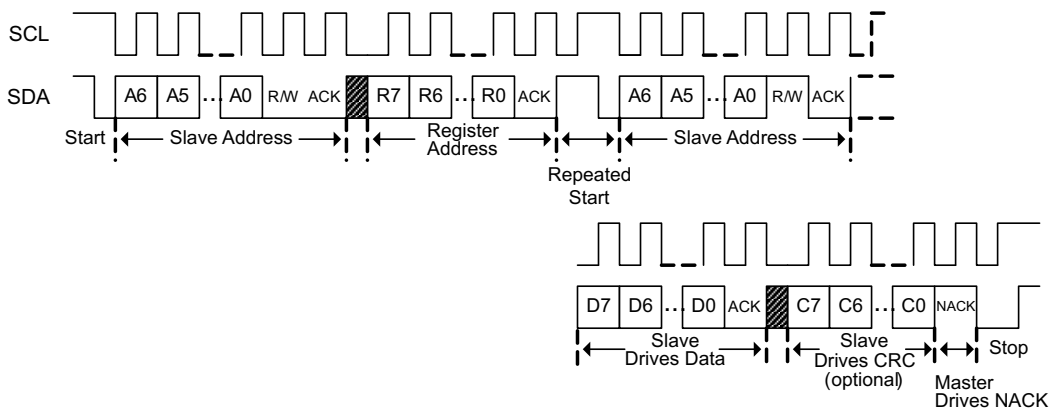

**Figure 8-4. I<sup>2</sup>C Read with Repeated Start**

Figure 8-5 shows a read transaction where a Repeated Start is not used, for example if not available in hardware. For a block read, the master ACK's each data byte except the last and continues to clock the interface. The I<sup>2</sup>C block will auto-increment the register address after each data byte.

When enabled, the CRC for a read transaction is calculated as follows:

- In a single-byte read transaction, the CRC is calculated after the second start and uses the slave address and data byte.
- In a block read transaction, the CRC for the first data byte is calculated after the second start and uses the slave address and data byte. The CRC for subsequent data bytes is calculated over the data byte only.

The CRC polynomial is  $x^8 + x^2 + x + 1$ , and the initial value is 0.

When the master detects a bad CRC, the I<sup>2</sup>C master will NACK the CRC, which causes the I<sup>2</sup>C slave to go to an idle state.

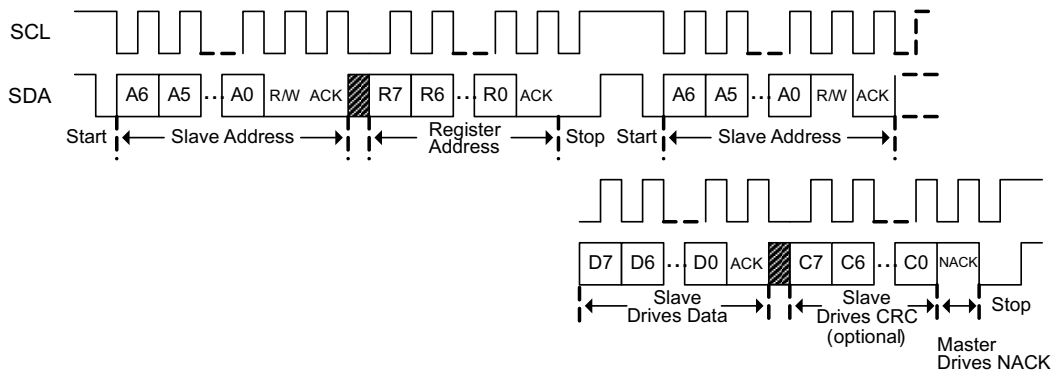

Figure 8-5. I<sup>2</sup>C Read Without Repeated Start

## 8.4 Device Functional Modes

Each BQ769x0 device supports the following modes of operation.

Table 8-2. Supported Power Modes

Mode	Description
NORMAL	Fully operational state. Both ADC and CC may be on, or disabled by host microcontroller. OV and UV protection enabled if ADC is on. OCD and SCD enabled. ADC and CC may be disabled to reduce power consumption, and CC may be operated in a “1-SHOT” mode for flexible power savings.
SHIP	Lowest possible power state, intended for pack assembly and/or longterm pack storage. Must see a BOOT signal ( $> 1 V_{BOOT}$ ) on TS1 pin to boot from SHIP → NORMAL. Note that the device always enters SHIP mode upon POR.

### 8.4.1 NORMAL Mode

NORMAL mode represents the fully operational mode where all blocks are enabled and the device sees its highest current consumption. In this mode, certain blocks/functions may be disabled to save power—these include the ADC and CC. OV and UV are running continuously as long as the ADC is enabled. The OCD and SCD comparators may not be disabled in this mode.

Transitioning from NORMAL to SHIP mode is also initiated by the host, and requires consecutive writes to two bits in the SYS\_CTRL1 register.

### 8.4.2 SHIP Mode

SHIP mode is the basic and lowest power mode that BQ769x0 supports. SHIP mode is automatically entered during initial pack assembly and after every POR event. When the device is in NORMAL mode, it may enter SHIP by the host controller through a specific sequence of I<sup>2</sup>C commands.

In SHIP mode, only a minimum of blocks is turned on, including the VSTUP power supply and primal boot detector. Waking from SHIP mode to NORMAL mode requires pulling the TS1 pin greater than  $V_{BOOT}$ , which triggers the device boot-up sequence.

To enter SHIP mode from NORMAL mode, the [SHUT\_A] and [SHUT\_B] bits in the SYS\_CTRL1 register must be written with specific patterns across two consecutive writes:

- Write #1: [SHUT\_A] = 0, [SHUT\_B] = 1
- Write #2: [SHUT\_A] = 1, [SHUT\_B] = 0

Note that [SHUT\_A] and [SHUT\_B] should each be in a 0 state prior to executing the shutdown command above. If this specific sequence is entered into the device, the device transitions into SHIP mode. If any other sequence is written to the [SHUT\_A] and [SHUT\_B] bits or if either of the two patterns is not correctly entered, the device will not enter SHIP mode.

**CAUTION**

DO NOT OPERATE THE DEVICE BELOW POR. When designing with the BQ76940, the intermediate voltages (BAT–VC10x), (VC10x–VC5x), and (VC5x–VSS) must each never fall below  $V_{SHUT}$ . When this occurs, a full device reset must be initiated by powering down all three intermediate voltages (BAT–VC10x), (VC10x–VC5x), and (VC5x–VSS) below  $V_{SHUT}$  and rebooting by applying the appropriate  $V_{BOOT}$  signal to the TS1 pin. When designing with the BQ76930, the intermediate voltages (BAT–VC5x) and (VC5x–VSS) must each never fall below  $V_{SHUT}$ . If this occurs, a full device reset must be initiated by powering down both intermediate voltages (BAT–VC5x) and (VC5x–VSS) below  $V_{SHUT}$  and rebooting by applying the appropriate  $V_{BOOT}$  signal to the TS1 pin.

The device will also enter SHIP mode during a POR event; however, this is not a recommended method of SHIP mode entry. If any of the supply-side voltages fall below  $V_{SHUT}$  and then back up above  $V_{PORA}$ , the device defaults into the SHIP mode state. This is similar to an initial pack assembly condition. In order to exit SHIP mode into NORMAL mode, the device must follow the standard boot sequence by applying a voltage greater than the  $V_{BOOT}$  threshold on the TS1 pin. The [BQ769x0 Boot Switch Alternatives Application Report](#) details multiple methods for generating the needed signal on the TS1 pin.

## 8.5 Register Maps

Name	Addr	D7	D6	D5	D4	D3	D2	D1	D0
SYS_STAT	0x00	CC_READY	RSVD	DEVICE_XREADY	OVRD_ALERT	UV	OV	SCD	OCD
CELLBAL1	0x01	RSVD	RSVD	RSVD	CB<5:1>				
CELLBAL2 <sup>(1)</sup>	0x02	RSVD	RSVD	RSVD	CB<10:6>				
CELLBAL3 <sup>(2)</sup>	0x03	RSVD	RSVD	RSVD	CB<15:11>				
SYS_CTRL1	0x04	LOAD_PRESENT	RSVD	RSVD	ADC_EN	TEMP_SEL	RSVD	SHUT_A	SHUT_B
SYS_CTRL2	0x05	DELAY_DIS	CC_EN	CC_ONESHOT	RSVD			DSG_ON	CHG_ON
PROTECT1	0x06	RSNS	RSVD	RSVD	SCD_DELAY		SCD_THRESH		
PROTECT2	0x07	RSVD	OCD_DELAY			OCD_THRESH			
PROTECT3	0x08	UV_DELAY		OV_DELAY		RSVD			
OV_TRIP	0x09	OV_THRESH							
UV_TRIP	0x0A	UV_THRESH							
CC_CFG	0x0B	RSVD	RSVD	Must be programmed to 0x19					
VC1_HI	0x0C	RSVD	RSVD	<13:8>					
VC1_LO	0x0D	<7:0>							
VC2_HI	0x0E	RSVD	RSVD	<13:8>					
VC2_LO	0x0F	<7:0>							
VC3_HI	0x10	RSVD	RSVD	<13:8>					
VC3_LO	0x11	<7:0>							
VC4_HI	0x12	RSVD	RSVD	<13:8>					
VC4_LO	0x13	<7:0>							
VC5_HI	0x14	RSVD	RSVD	<13:8>					
VC5_LO	0x15	<7:0>							
VC6_HI <sup>(1)</sup>	0x16	RSVD	RSVD	<13:8>					
VC6_LO <sup>(1)</sup>	0x17	<7:0>							
VC7_HI <sup>(1)</sup>	0x18	RSVD	RSVD	<13:8>					
VC7_LO <sup>(1)</sup>	0x19	<7:0>							
VC8_HI <sup>(1)</sup>	0x1A	RSVD	RSVD	<13:8>					
VC8_LO <sup>(1)</sup>	0x1B	<7:0>							
VC9_HI <sup>(1)</sup>	0x1C	RSVD	RSVD	<13:8>					
VC9_LO <sup>(1)</sup>	0x1D	<7:0>							
VC10_HI <sup>(1)</sup>	0x1E	RSVD	RSVD	<13:8>					
VC10_LO <sup>(1)</sup>	0x1F	<7:0>							
VC11_HI <sup>(2)</sup>	0x20	RSVD	RSVD	<13:8>					
VC11_LO <sup>(2)</sup>	0x21	<7:0>							
VC12_HI <sup>(2)</sup>	0x22	RSVD	RSVD	<13:8>					
VC12_LO <sup>(2)</sup>	0x23	<7:0>							
VC13_HI <sup>(2)</sup>	0x24	RSVD	RSVD	<13:8>					
VC13_LO <sup>(2)</sup>	0x25	<7:0>							
VC14_HI <sup>(2)</sup>	0x26	RSVD	RSVD	<13:8>					
VC14_LO <sup>(2)</sup>	0x27	<7:0>							
VC15_HI <sup>(2)</sup>	0x28	RSVD	RSVD	<13:8>					
VC15_LO <sup>(2)</sup>	0x29	<7:0>							
BAT_HI	0x2A	<15:8>							
BAT_LO	0x2B	<7:0>							
TS1_HI	0x2C	RSVD	RSVD	<13:8>					
TS1_LO	0x2D	<7:0>							
TS2_HI <sup>(1)</sup>	0x2E	RSVD	RSVD	<13:8>					

Name	Addr	D7	D6	D5	D4	D3	D2	D1	D0
TS2_LO <sup>(1)</sup>	0x2F	<7:0>							
TS3_HI <sup>(2)</sup>	0x30	RSVD	RSVD	<13:8>					
TS3_LO <sup>(2)</sup>	0x31	<7:0>							
CC_HI	0x32	<15:8>							
CC_LO	0x33	<7:0>							
ADCGAIN1	0x50	RSVD				ADCGAIN<4:3>		RSVD	
ADCOFFSET	0x51	ADCOFFSET<7:0>							
ADCGAIN2	0x59	ADCGAIN<2:0>				RSVD			

(1) These registers are only valid for BQ76930 and BQ76940.

(2) These registers are only valid for BQ76940.

## 8.5.1 Register Details

**Table 8-3. SYS\_STAT (0x00)**

BIT	7	6	5	4	3	2	1	0
NAME	CC_READY	RSVD	DEVICE_XREADY	OVRD_ALERT	UV	OV	SCD	OCD
RESET	0	0	0	0	0	0	0	0
ACCESS	RW	RW	RW	RW	RW	RW	RW	RW

### Note

Bits in SYS\_STAT may be cleared by writing a "1" to the corresponding bit.

Writing a "0" does not change the state of the corresponding bit.

**CC\_READY (Bit 7):** Indicates that a fresh coulomb counter reading is available. Note that if this bit is not cleared between two adjacent CC readings becoming available, the bit remains latched to 1. This bit may only be cleared (and not set) by the host.

0 = Fresh CC reading not yet available or bit is cleared by host microcontroller.

1 = Fresh CC reading is available. Remains latched high until cleared by host.

**RSVD (Bit 6):** Reserved. Do not use.

**DEVICE\_XREADY (Bit 5):** Internal chip fault indicator. When this bit is set to 1, it should be cleared by the host. May be set due to excessive system transients. This bit may only be cleared (and not set) by the host.

0 = Device is OK.

1 = Internal chip fault detected, recommend that host microcontroller clear this bit after waiting a few seconds. Remains latched high until cleared by the host.

**OVRD\_ALERT (Bit 4):** External pull-up on the ALERT pin indicator. Only active when ALERT pin is not already being driven high by the AFE itself.

0 = No external override detected

1 = External override detected. Remains latched high until cleared by the host.

**UV (Bit 3):** Undervoltage fault event indicator.

0 = No UV fault is detected.

1 = UV fault is detected. Remains latched high until cleared by the host.

**OV (Bit 2):** Overvoltage fault event indicator.

0 = No OV fault is detected.

1 = OV fault is detected. Remains latched high until cleared by the host.

**SCD (Bit 1):** Short circuit in discharge fault event indicator.

0 = No SCD fault is detected.

1 = SCD fault is detected. Remains latched high until cleared by the host.

**OCD (Bit 0):** Over current in discharge fault event indicator.

0 = No OCD fault is detected.

1 = OCD fault is detected. Remains latched high until cleared by the host.

**Table 8-4. CELLBAL1 (0x01) for BQ76920, BQ76930, and BQ76940**

BIT	7	6	5	4	3	2	1	0
NAME	—	—	—	CB5	CB4	CB3	CB2	CB1
RESET	0	0	0	0	0	0	0	0
ACCESS	R	R	R	RW	RW	RW	RW	RW

**CBx (Bits 4–0):**

0 = Cell balancing on Cell “x” is disabled.

1 = Cell balancing on Cell “x” is enabled.

**Table 8-5. CELLBAL2 (0x02) for BQ76930 and BQ76940**

BIT	7	6	5	4	3	2	1	0
NAME	—	—	—	CB10	CB9	CB8	CB7	CB6
RESET	0	0	0	0	0	0	0	0
ACCESS	R	R	R	RW	RW	RW	RW	RW

**CBx (Bits 4–0):**

0 = Cell balancing on Cell “x” is disabled.

1 = Cell balancing on Cell “x” is enabled.

**Table 8-6. CELLBAL3 (0x03) for BQ76940**

BIT	7	6	5	4	3	2	1	0
NAME	—	—	—	CB15	CB14	CB13	CB12	CB11
RESET	0	0	0	0	0	0	0	0
ACCESS	R	R	R	RW	RW	RW	RW	RW

**CBx (Bits 4–0):**

0 = Cell balancing on Cell “x” is disabled.

1 = Cell balancing on Cell “x” is enabled.

**Table 8-7. SYS\_CTRL1 (0x04)**

BIT	7	6	5	4	3	2	1	0
NAME	LOAD_PRESENT	—	—	ADC_EN	TEMP_SEL	RSVD	SHUT_A	SHUT_B
RESET	0	0	0	0	0	0	0	0
ACCESS	R	R	R	RW	RW	RW	RW	RW

**LOAD\_PRESENT (Bit 7):** Valid only when [CHG\_ON] = 0. Is high if CHG pin is detected to exceed VLOAD\_DETECT while CHG\_ON = 0, which suggests that external load is present. Note this bit is read-only and automatically clears when load is removed.

0 = CHG pin < VLOAD\_DETECT or [CHG\_ON] = 1.

1 = CHG pin > VLOAD\_DETECT, while [CHG\_ON] = 0.

**ADC\_EN (Bit 4):** ADC enable command

0 = Disable voltage and temperature ADC readings (also disables OV protection)

1 = Enable voltage and temperature ADC readings (also enables OV protection)

**TEMP\_SEL (Bit 3):** TSx\_HI and TSx\_LO temperature source

0 = Store internal die temperature voltage reading in TSx\_HI and TSx\_LO

1 = Store thermistor reading in TSx\_HI and TSx\_LO (all thermistor ports)

**RSVD (Bit 2):** Reserved, do not set to 1.

**SHUT\_A, SHUT\_B (Bits 1–0):** Shutdown command from host microcontroller. Must be written in a specific sequence, shown below:

Starting from: [SHUT\_A] = 0, [SHUT\_B] = 0

Write #1: [SHUT\_A] = 0, [SHUT\_B] = 1

Write #2: [SHUT\_A] = 1, [SHUT\_B] = 0

Other writes cause the command to be ignored.

**Table 8-8. SYS\_CTRL2 (0x05)**

BIT	7	6	5	4	3	2	1	0
NAME	DELAY_DIS	CC_EN	CC_ONESHOT	RSVD	RSVD	RSVD	DSG_ON	CHG_ON
RESET	0	0	0	0	0	0	0	0
ACCESS	RW	RW	RW	RW	RW	RW	RW	RW

**DELAY\_DIS (Bit 7):** Disable OV, UV, OCD, and SCD delays for faster customer production testing.

0 = Normal delay settings

1 = OV, UV, OCD, and SCD delay circuit is bypassed, creating zero delay (approximately 250 ms).

**CC\_EN (Bit 6):** Coulomb counter continuous operation enable command. If set high, [CC\_ONESHOT] bit is ignored.

0 = Disable CC continuous readings

1 = Enable CC continuous readings and ignore [CC\_ONESHOT] state

**CC\_ONESHOT (Bit 5):** Coulomb counter single 250-ms reading trigger command. If set to 1, the coulomb counter will be activated for a single 250-ms reading, and then turned back off. [CC\_ONESHOT] will also be cleared at the conclusion of this reading, while [CC\_READY] bit will be set to 1.

0 = No action

1 = Enable single CC reading (only valid if [CC\_EN] = 0), and [CC\_READY] = 0

**RSVD (Bits 4–2):** Reserved. Do not use.

**DSG\_ON (Bit 1):** Discharge FET driver (low side NCH) or discharge signal control

0 = DSG is off.

1 = DSG is on.

**CHG\_ON (Bit 0):** Discharge FET driver (low side NCH) or discharge signal control

0 = CHG is off.

1 = CHG is on.

**Table 8-9. PROTECT1 (0x06)**

BIT	7	6	5	4	3	2	1	0
NAME	RSNS	—	RSVD	SCD_D1	SCD_D0	SCD_T2	SCD_T1	SCD_T0
RESET	0	0	0	0	0	0	0	0
ACCESS	RW	R	RW	RW	RW	RW	RW	RW

**RSNS (Bit 7):** Allows for doubling the OCD and SCD thresholds simultaneously

0 = OCD and SCD thresholds at lower input range

1 = OCD and SCD thresholds at upper input range

**RSVD (Bit 5):** Reserved, do not set to 1.

**SCD\_D1:0 (Bits 4–3):** Short circuit in discharge delay setting. A 400- $\mu$ s setting is recommended only in systems using maximum cell measurement input resistance, R<sub>c</sub>, of 1 k $\Omega$  (which corresponds to minimum internal cell balancing current or external cell balancing configuration).

Code	(in $\mu$ s)
0x0	70
0x1	100
0x2	200
0x3	400

**SCD\_T2:0 (Bits 2–0):** Short circuit in discharge threshold setting

Code	RSNS = 1 (in mV)	RSNS = 0 (in mV)
0x0	44	22
0x1	67	33
0x2	89	44
0x3	111	56
0x4	133	67
0x5	155	78
0x6	178	89
0x7	200	100

**Table 8-10. PROTECT2 (0x07)**

BIT	7	6	5	4	3	2	1	0
NAME	—	OCD_D2	OCD_D1	OCD_D0	OCD_T3	OCD_T2	OCD_T1	OCD_T0
RESET	0	0	0	0	0	0	0	0
ACCESS	R	RW	RW	RW	RW	RW	RW	RW

**OCD\_D2:0 (Bits 6–4):** Overcurrent in discharge delay setting

Code	(in ms)
0x0	8
0x1	20
0x2	40
0x3	80
0x4	160
0x5	320
0x6	640
0x7	1280

**OCD\_T3:0 (Bits 3–0):** Overcurrent in discharge threshold setting

Code	RSNS = 1 (in mV)	(RSNS = 0 (in mV)
0x0	17	8
0x1	22	11
0x2	28	14
0x3	33	17
0x4	39	19
0x5	44	22
0x6	50	25
0x7	56	28
0x8	61	31
0x9	67	33

Code	RSNS = 1 (in mV)	(RSNS = 0 (in mV)
0xA	72	36
0xB	78	39
0xC	83	42
0xD	89	44
0xE	94	47
0xF	100	50

**Table 8-11. PROTECT3 (0x08)**

BIT	7	6	5	4	3	2	1	0
NAME	UV_D1	UV_D0	OV_D1	OV_D0	RSVD	RSVD	RSVD	RSVD
RESET	0	0	0	0	0	0	0	0
ACCESS	RW	RW	RW	RW	RW	RW	RW	RW

**UV\_D1:0 (Bits 7–6):** Undervoltage delay setting

Code	(in s)
0x0	1
0x1	4
0x2	8
0x3	16

**OV\_D1:0 (Bits 5–4):** Overvoltage delay setting

Code	(in s)
0x0	1
0x1	2
0x2	4
0x3	8

**RSVD (Bits 3–0):** These bits are for TI internal debug use only and must be configured to the default settings indicated.

**Table 8-12. OV\_TRIP (0x09)**

BIT	7	6	5	4	3	2	1	0
NAME	OV_T7	OV_T6	OV_T5	OV_T4	OV_T3	OV_T2	OV_T1	OV_T0
RESET	1	0	1	0	1	1	0	0
ACCESS	RW	RW	RW	RW	RW	RW	RW	RW

**OV\_T7:0 (Bits 7–0):** Middle 8 bits of the direct ADC mapping of the desired OV protection threshold, with upper 2 MSB set to 10 and lower 4 LSB set to 1000. The equivalent OV threshold is mapped to:  
 $10 \cdot \text{OV\_T} < 7:0 > > 1000$ .

By default, OV\_TRIP is configured to a 0xAC setting.

Note that OV\_TRIP is based on the ADC voltage, which requires back-calculation using the GAIN and OFFSET values stored in ADCGAIN<4:0> and ADCOFFSET<7:0>.

**Table 8-13. UV\_TRIP (0x0A)**

BIT	7	6	5	4	3	2	1	0
NAME	UV_T7	UV_T6	UV_T5	UV_T4	UV_T3	UV_T2	UV_T1	UV_T0
RESET	1	0	0	1	0	1	1	1
ACCESS	RW	RW	RW	RW	RW	RW	RW	RW

**UV\_T7:0 (Bits 7–0):** Middle 8 bits of the direct ADC mapping of the desired UV protection threshold, with upper 2 MSB set to 01 and lower 4 LSB set to 0000. In other words, the equivalent OV threshold is mapped to: 01-UV\_T<7:0>-0000.

By default, UV\_TRIP is configured to a 0x97 setting.

Note that UV\_TRIP is based on the ADC voltage, which requires back-calculation using the GAIN and OFFSET values stored in AD CGAIN<4:0> and ADCOFFSET<7:0>.

**Table 8-14. CC\_CFG REGISTER (0x0B)**

BIT	7	6	5	4	3	2	1	0
NAME	—	—	CC_CFG5	CC_CFG4	CC_CFG3	CC_CFG2	CC_CFG1	CC_CFG0
RESET	0	0	0	0	0	0	0	0
ACCESS	R	R	RW	RW	RW	RW	RW	RW

**CC\_CFG5:0 (Bits 5–0):** For optimal performance, these bits should be programmed to 0x19 upon device startup.

## 8.5.2 Read-Only Registers

**Table 8-15. CELL VOLTAGE REGISTERS**

VC1\_HI, \_LO (0x0C–0x0D), VC2\_HI, \_LO (0x0E–0x0F), VC3\_HI, \_LO (0x10–0x11), VC4\_HI, \_LO (0x12–0x13), VC5\_HI, \_LO (0x14–0x15) / BQ76930, BQ76940: VC6\_HI, \_LO (0x16–0x17), VC7\_HI, \_LO (0x18–0x19), VC8\_HI, \_LO (0x1A–0x1B), VC9\_HI, \_LO (0x1C–0x1D), VC10\_HI, \_LO (0x1E–0x1F) / BQ76940: VC11\_HI, \_LO (0x20–0x21), VC12\_HI, \_LO (0x22–0x23), VC13\_HI, \_LO (0x24–0x25), VC14\_HI, \_LO (0x26–0x27), VC15\_HI, \_LO (0x28–0x29)

BIT	7	6	5	4	3	2	1	0
NAME	—	—	D13	D12	D11	D10	D9	D8
RESET	0	0	0	0	0	0	0	0
NAME	D7	D6	D5	D4	D3	D2	D1	D0
RESET	0	0	0	0	0	0	0	0

**D11:8 (Bits 3–0):** Cell “x” ADC reading, upper 6 MSB. Always returned as an atomic value if both high and low registers are read in the same transaction (using address auto-increment).

**D7:0 (Bits 7–0):** Cell “x” ADC reading, lower 8 LSB.

**Table 8-16. BAT\_HI (0x2A) and BAT\_LO (0x2B)**

BIT	7	6	5	4	3	2	1	0
NAME	D15	D14	D13	D12	D11	D10	D9	D8
RESET	0	0	0	0	0	0	0	0
NAME	D7	D6	D5	D4	D3	D2	D1	D0
RESET	0	0	0	0	0	0	0	0

**D15:8 (Bits 7–0):** BAT calculation based on adding up Cells 1–15, upper 8 MSB. Always returned as an atomic value if both high and low registers are read in the same transaction (using address auto-increment).

**D7:0 (Bits 7–0):** BAT calculation based on adding up Cells 1–15, lower 8 LSB

**Table 8-17. TS1\_HI (0x2C) and TS1\_LO (0x2D)**

BIT	7	6	5	4	3	2	1	0
NAME	—	—	D13	D12	D11	D10	D9	D8
RESET	0	0	0	0	0	0	0	0
NAME	D7	D6	D5	D4	D3	D2	D1	D0
RESET	0	0	0	0	0	0	0	0

**D11:8 (Bits 3–0):** TS1 or DIETEMP ADC reading, upper 6 MSB. Always returned as an atomic value if both high and low registers are read in the same transaction (using address auto-increment).

**D7:0 (Bits 7–0):** TS1 or DIETEMP ADC reading, lower 8 LSB

**Table 8-18. TS2\_HI (0x2E) and TS2\_LO (0x2F)**

BIT	7	6	5	4	3	2	1	0
NAME	—	—	D13	D12	D11	D10	D9	D8
RESET	0	0	0	0	0	0	0	0
NAME	D7	D6	D5	D4	D3	D2	D1	D0
RESET	0	0	0	0	0	0	0	0

**D11:8 (Bits 3–0):** TS2 ADC reading, upper 6 MSB. Always returned as an atomic value if both high and low registers are read in the same transaction (using address auto-increment).

**D7:0 (Bits 7–0):** TS2 ADC reading, lower 8 LSB

**Table 8-19. TS3\_HI (0x30) and TS3\_LO (0x31)**

BIT	7	6	5	4	3	2	1	0
NAME	—	—	D13	D12	D11	D10	D9	D8
RESET	0	0	0	0	0	0	0	0
NAME	D7	D6	D5	D4	D3	D2	D1	D0
RESET	0	0	0	0	0	0	0	0

**D11:8 (Bits 3–0):** TS3 ADC reading, upper 6 MSB. Always returned as an atomic value if both high and low registers are read in the same transaction (using address auto-increment).

**D7:0 (Bits 7–0):** TS3 ADC reading, lower 8 LSB

**Table 8-20. CC\_HI (0x32) and CC\_LO (0x33)**

BIT	7	6	5	4	3	2	1	0
NAME	CC15	CC14	CC13	CC12	CC11	CC10	CC9	CC8
RESET	0	0	0	0	0	0	0	0
NAME	CC7	CC6	CC5	CC4	CC3	CC2	CC1	CC0
RESET	0	0	0	0	0	0	0	0

**CC15:8 (Bits 7–0):** Coulomb counter upper 8 MSB. Always returned as an atomic value if both high and low registers are read in the same transaction (using address auto-increment).

**CC7:0 (Bits 7–0):** Coulomb counter lower 8 LSB

**Table 8-21. ADCGAIN1 (0x50)**

BIT	7	6	5	4	3	2	1	0
NAME	—	—	—	—	ADCGAIN4	ADCGAIN3	—	—
RESET	—	—	—	—	—	—	—	—
ACCESS	R	R	R	R	R	R	R	R

**Table 8-22. ADCGAIN2 (0x59)**

BIT	7	6	5	4	3	2	1	0
NAME	ADCGAIN2	ADCGAIN1	ADCGAIN0	—	—	—	—	—
RESET	—	—	—	—	—	—	—	—
ACCESS	R	R	R	R	R	R	R	R

**ADCGAIN4:3 (Bits 3–2, address 0x50):**

ADC GAIN offset upper 2 MSB

**ADCGAIN2:0 (Bits 7–5, address 0x59):**

ADC GAIN offset lower 3 LSB

ADCGAIN<4:0> is a production-trimmed value for the ADC transfer function, in units of  $\mu\text{V}/\text{LSB}$ . The range is 365  $\mu\text{V}/\text{LSB}$  to 396  $\mu\text{V}/\text{LSB}$ , in steps of 1  $\mu\text{V}/\text{LSB}$ , and may be calculated as follows:

$$\text{GAIN} = 365 \mu\text{V}/\text{LSB} + (\text{ADCGAIN}\langle 4:0 \rangle \text{in decimal}) \times (1 \mu\text{V}/\text{LSB})$$

Alternately, a conversion table is provided below:

ADC GAIN	Gain ( $\mu\text{V}/\text{LSB}$ )	ADC GAIN	Gain ( $\mu\text{V}/\text{LSB}$ )
0x00	365	0x10	381
0x01	366	0x11	382
0x02	367	0x12	383
0x03	368	0x13	384
0x04	369	0x14	385
0x05	370	0x15	386
0x06	371	0x16	387
0x07	372	0x17	388
0x08	373	0x18	389
0x09	374	0x19	390
0x0A	375	0x1A	391
0x0B	376	0x1B	392
0x0C	377	0x1C	393
0x0D	378	0x1D	394
0x0E	379	0x1E	395
0x0F	380	0x1F	396

**Table 8-23. ADCOFFSET (0x51)**

BIT	7	6	5	4	3	2	1	0
NAME	ADC OFFSET7	ADC OFFSET6	ADC OFFSET5	ADC OFFSET4	ADC OFFSET3	ADC OFFSET2	ADC OFFSET1	ADC OFFSET0
RESET	—	—	—	—	—	—	—	—
ACCESS	R	R	R	R	R	R	R	R

**ADCOFFSET7:0 (Bits 7–0):**

ADC offset, stored in 2's complement format in mV units. Positive full-scale range corresponds to 0x7F and negative full-scale corresponds to 0x80. The full-scale input range is  $-128 \text{ mV}$  to  $127 \text{ mV}$ , with an LSB of 1 mV.

The table below shows example offsets.

ADCOFFSET	Offset (mV)
0x00	0
0x01	1
0x7F	127
0x80	-128
0x81	-127
0xFF	-1

## 9 Application and Implementation

---

### Note

Information in the following applications sections is not part of the TI component specification, and TI does not warrant its accuracy or completeness. TI's customers are responsible for determining suitability of components for their purposes, as well as validating and testing their design implementation to confirm system functionality.

---

### 9.1 Application Information

The BQ769x0 family of battery monitoring AFEs enabling cell parametric measurement and protection is a variety of 3-series to 15-series Li-ion/li-polymer battery packs.

To evaluate the performance and configurations of the device users need the , [BQ76940](#), [BQ76930](#), and [BQ76920 Evaluation Software](#) tool to configure the internal registers for a specific battery pack and application. The Evaluation Software tool is a graphical user-interface tool installed on a PC during development. This can be used in conjunction with the BQ76920EVM, BQ76930EVM or BQ76940EVM.

The BQ769x0 devices are expected to be implemented in a system with a microcontroller that can perform additional functions based on the data made collected. The [BQ78350-R1](#) is one example of a companion to the BQ769x0 family. Additional application information is available in the [BQ769x0 Family Top Design Considerations Application Report](#).

#### 9.1.1 Device Timing

The device timeline accuracy is typically 3.5%. Each five-cell group in the BQ76930 and BQ76940 devices uses an independent 250-ms timeline, so voltage and temperature measurements of different groups drift with respect to one another.

#### 9.1.2 Random Cell Connection

The device design anticipated transient conditions during cell connection, but that design did not result in unique specifications. The large component value ranges used in the application circuits may require special considerations for random cell connection. See additional information in the [BQ769x0 Family Top Design Considerations Application Report](#).

#### 9.1.3 Power Pin Diodes

The VC5X, VC10X, and BAT pins must have a diode from the top group input to the associated power pin, as shown in [Figure 9-2](#) and [Figure 9-3](#). These diodes limit the excursion of the input voltage above the supply. The diodes should be conventional diodes rather than Schottky type to allow some variation of the supply voltage without loading the cell input. When needed, two diodes may be used in series.

#### 9.1.4 Alert Pin

The ALERT pin is an input and output. The input is sensitive to noise and may benefit from a RC filter at the pin to reduce noise at the pin. A maximum 250- $\mu$ s time constant is suggested to allow the pin to fall when it is cleared as an output before it is sampled as an input. 500-k $\Omega$  and 470-pF values are commonly recommended. Guard traces around the traces may be helpful to avoid crosstalk to the ALERT trace.

#### 9.1.5 Sense Inputs

The SRP input should operate near VSS, so VSS references the battery negative on the battery side of the sense resistor near the filter connection for SRP. The SRP and SRN have a common mode range to their supply from REGOUT and the VSS rail. When moving away from the recommended level due to high current or a buffer amplifier, the OCD and SCD may still trip, but accuracy could be compromised.

#### 9.1.6 TSn Pins

The TSn pins must connect with a thermistor or resistor to the reference power pin for the associated cell group, as shown in the applications diagram. A resistor must be connected for normal operation even if external

temperature measurement is not used. When thermistors are removable, they should be substituted with a test resistance at board test to prevent XREADY faults during test. The TS<sub>n</sub> pins should not be pulled below their reference power pin or the device may not start properly or the ADC may not operate properly.

A capacitor across the thermistor is not required but may filter noise picked up by thermistor leads. The thermistor is biased 37.5 ms before measurement begins, so a 4.7-nF capacitor, such as is used on the evaluation module or smaller, allows many time constants for settling before measurement.

#### Note

The capacitor across the thermistor does not filter noise that may be picked up by the thermistor leads between different thermistors on the BQ76930 or BQ76940 devices.

TS1 is also used to boot the part. A rising edge is required for boot. A high level maintained on TS1 does not prevent shutdown or waking the part. A voltage level maintained on the TS1 pin after boot affects the voltage on the thermistor and the temperature determined by the MCU if external temperature sensing is used in normal operation.

### 9.1.7 Unused Pins

Pins should be connected to the appropriate circuits, as shown in the simplified diagrams in [Typical Applications](#) and as described in the [Pin Configuration and Functions](#) section. See [Pin Usage](#) for additional comments.

**Table 9-1. Pin Usage**

PIN NAME	RECOMMENDATION
DSG, CHG	DSG and CHG are outputs and may be left unconnected if not used.
VSS	Must be used
SDA, SCL	Must be used
TS <sub>n</sub>	Must have a thermistor or pull down resistor to the group reference. TS1 must have a rising edge to boot the part.
CAP <sub>n</sub>	A capacitor must be installed.
REGOUT	REGOUT also supplies internal circuits. A capacitor must be installed even if REGOUT is not used for external circuitry.
REGSRC	Must be supplied
BAT	Primary power pin for the part, must be connected to the top cell through the power filter
VC5x, VC10x	Must connect to the appropriate cell through the power filter
NC	Some pins named NC must be connected to the appropriate CAP <sub>n</sub> pin. See <a href="#">Pin Configuration and Functions</a> .
VC <sub>n</sub>	Cell voltage sense input pins. Must be connected through the input filter to the cells. When not all cells are needed, connect as described in <a href="#">Configuring Alternative Cell Counts</a> .
SRP, SRN	Current sense inputs. When not used, connect to VSS.
ALERT	When not used, a pulldown is recommended. See <a href="#">Alert Pin</a> .

### 9.1.8 Configuring Alternative Cell Counts

Each BQ769x0 family of IC's support a variety of cell counts. The following tables provide guidance on which device and which input pins to use, depending on the number of cells in the pack.

**Table 9-2. Cell Connections for BQ76920**

Cell Input	3 Cells	4 Cells	5 Cells
VC5–VC4	CELL 3	CELL 4	CELL 5
VC4–VC3	short	short	CELL 4
VC3–VC2	short	CELL 3	CELL 3
VC2–VC1	CELL 2	CELL 2	CELL 2

**Table 9-2. Cell Connections for BQ76920 (continued)**

Cell Input	3 Cells	4 Cells	5 Cells
VC1–VC0	CELL 1	CELL 1	CELL 1

**Table 9-3. Cell Connections for BQ76930**

Cell Input	6 Cells	7 Cells	8 Cells	9 Cells	10 Cells
VC10–VC9	CELL 6	CELL 7	CELL 8	CELL 9	CELL 10
VC9–VC8	short	short	short	short	CELL 9
VC8–VC7	short	short	CELL 7	CELL 8	CELL 8
VC7–VC6	CELL 5	CELL 6	CELL 6	CELL 7	CELL 7
VC6–VC5b	CELL 4	CELL 5	CELL 5	CELL 6	CELL 6
VC5–VC4	CELL 3	CELL 4	CELL 4	CELL 5	CELL 5
VC4–VC3	short	short	short	CELL 4	CELL 4
VC3–VC2	short	CELL 3	CELL 3	CELL 3	CELL 3
VC2–VC1	CELL 2	CELL 2	CELL 2	CELL 2	CELL 2
VC1–VC0	CELL 1	CELL 1	CELL 1	CELL 1	CELL 1

**Table 9-4. Cell Connections for BQ76940**

Cell Input	9 Cells	10 Cells	11 Cells	12 Cells	13 Cells	14 Cells	15 Cells
VC15–VC14	CELL 9	CELL 10	CELL 11	CELL 12	CELL 13	CELL 14	CELL 15
VC14–VC13	short	short	short	short	short	short	CELL 14
VC13–VC12	short	short	short	CELL 11	CELL 12	CELL 13	CELL 13
VC12–VC11	CELL 8	CELL 9	CELL 10	CELL 10	CELL 11	CELL 12	CELL 12
VC11–VC10b	CELL 7	CELL 8	CELL 9	CELL 9	CELL 10	CELL 11	CELL 11
VC10–VC9	CELL 6	CELL 7	CELL 8	CELL 8	CELL 9	CELL 10	CELL 10
VC9–VC8	short	short	short	short	short	CELL 9	CELL 9
VC8–VC7	short	short	CELL 7	CELL 7	CELL 8	CELL 8	CELL 8
VC7–VC6	CELL 5	CELL 6	CELL 6	CELL 6	CELL 7	CELL 7	CELL 7
VC6–VC5b	CELL 4	CELL 5	CELL 5	CELL 5	CELL 6	CELL 6	CELL 6
VC5–VC4	CELL 3	CELL 4	CELL 4	CELL 4	CELL 5	CELL 5	CELL 5
VC4–VC3	short	short	short	short	CELL 4	CELL 4	CELL 4
VC3–VC2	short	CELL 3	CELL 3	CELL 3	CELL 3	CELL 3	CELL 3
VC2–VC1	CELL 2	CELL 2	CELL 2	CELL 2	CELL 2	CELL 2	CELL 2
VC1–VC0	CELL 1	CELL 1	CELL 1	CELL 1	CELL 1	CELL 1	CELL 1



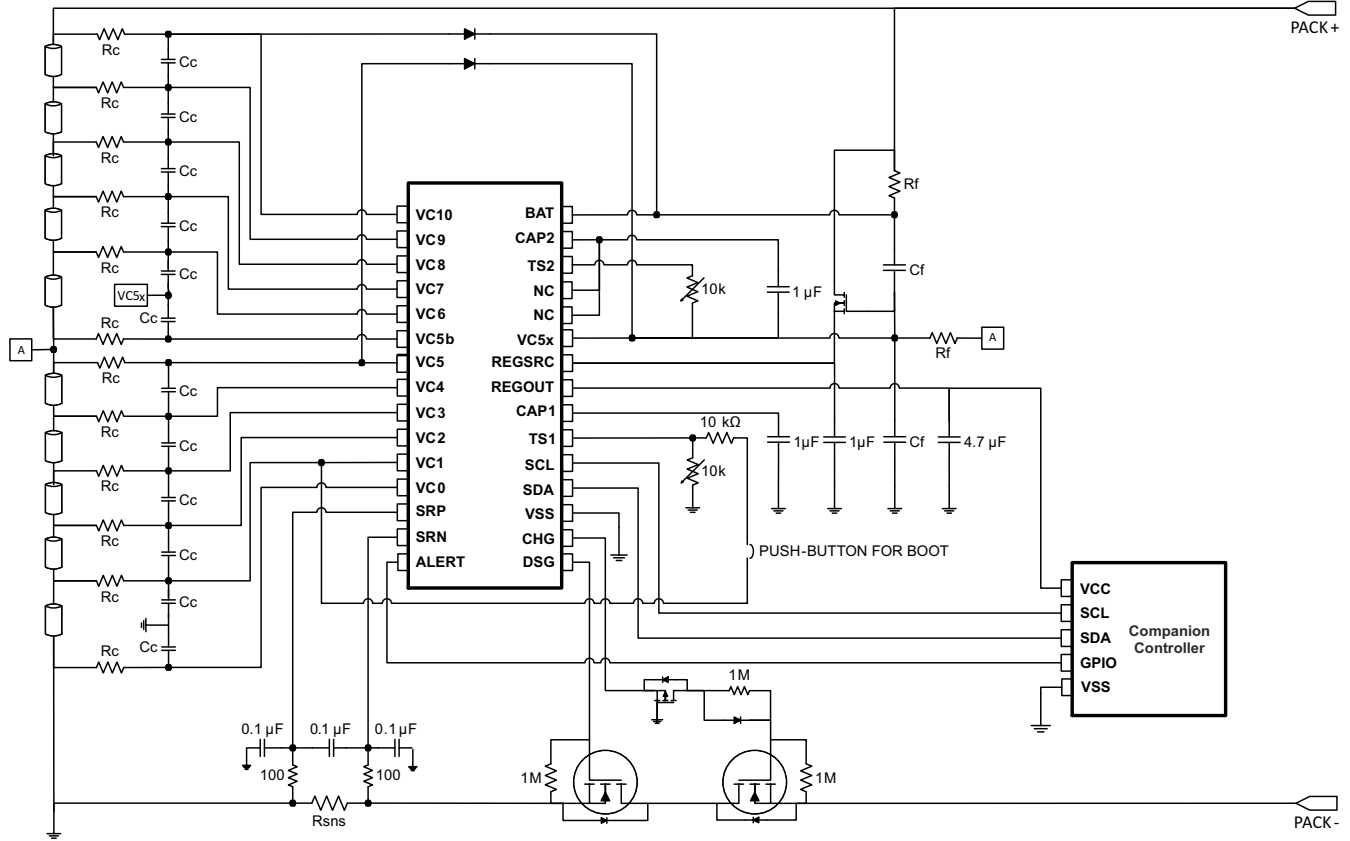

Copyright © 2016, Texas Instruments Incorporated

**Figure 9-2. BQ76930 With BQ78350 Companion Controller IC**

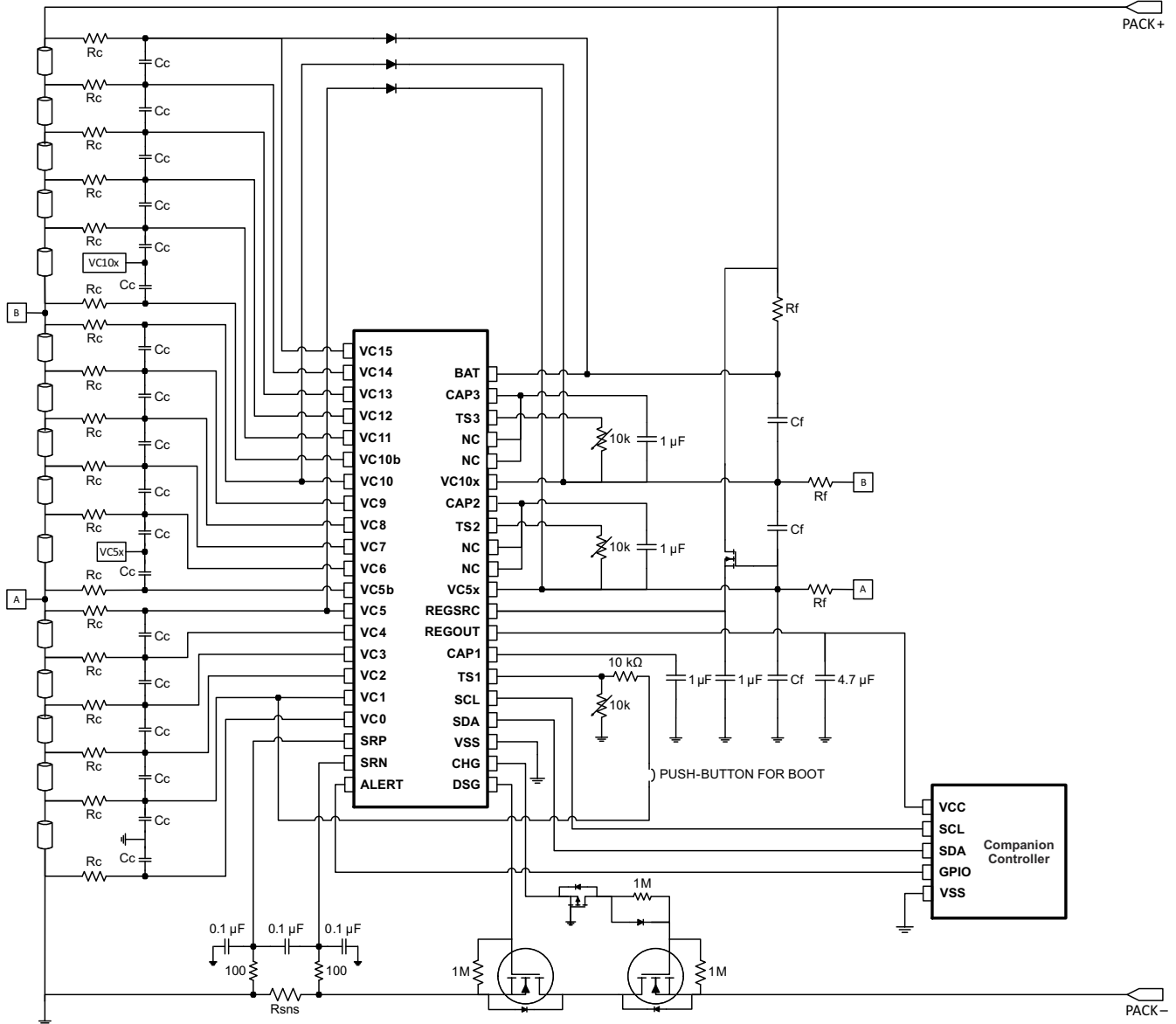

**Figure 9-3. BQ76940 with BQ78350 Companion Controller IC**

Copyright © 2016, Texas Instruments Incorporated

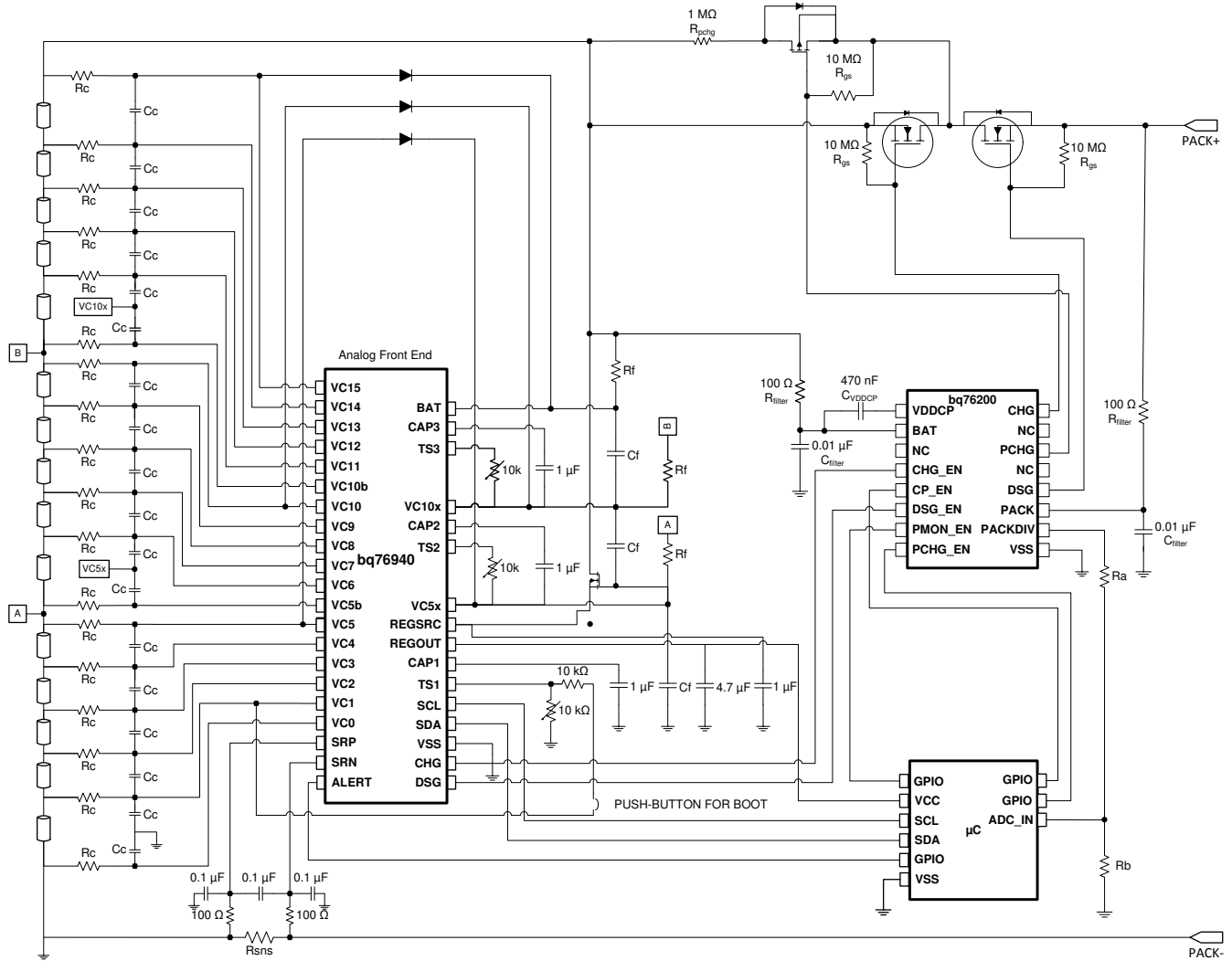

**Figure 9-4. BQ76940 with BQ78350 Companion Controller IC and BQ76200 High-Side N-Channel FET Driver**

**9.2.1 Design Requirements**

**Table 9-5. BQ769x0 Design Requirements**

DESIGN PARAMETER	EXAMPLE VALUE at T <sub>A</sub> = 25°C
Minimum system operating voltage	24 V
Cell minimum operating voltage	3.0 V
Series Cell Count	8
Charge Voltage	33.6 V
Maximum Charge Current	3.0 A
Peak Discharge Current	10.0 A
OV Protection Threshold	4.30 V
OV Protection Delay	2s
UV Protection Threshold	2.5 V
UV Protection Delay	4s
OCD Protection Threshold Max	15 A
OCD Protection Delay Time	320 ms
SCD Protection Threshold Max	25 A

**Table 9-5. BQ769x0 Design Requirements (continued)**

DESIGN PARAMETER	EXAMPLE VALUE at T <sub>A</sub> = 25°C
SCD Protection Delay Time	100 μs

## 9.2.2 Detailed Design Procedure

To begin the design process, there are some key steps required for component selection and protection configuration.

### 9.2.2.1 Step-by-Step Design Procedure

- Determine the number of series cells.
  - This value depends on the cell chemistry and the load requirements of the system. For example, to support a minimum battery voltage of 24 V using Li-CO<sub>2</sub> type cells with a cell minimum voltage of 3.0 V, there needs to be at least 8-series cells.
- Select the correct BQ769x0 device.
  - For 8-series cells, the BQ76930 is needed.
  - For the correct cell connections, see [Table 9-3](#).
- Select the correct protection FETs.
  - The BQ76930 uses a low-side drive suitable for N-CH FETs.
  - These FETs should be rated for the maximum:
    - Voltage, which should be approximately 5 V (DC) 10 V (peak) per series cell: for example, 40 V.
    - Current, which should be calculated based on both the maximum DC current and the maximum transient current with some margin: for example, 30 A.
    - Power Dissipation, which can be a factor of the RDS(ON) rating of the FET, the FET package, and the PCB design: for example, 5 W, assuming 5 mΩ RDS(ON).
- Select the correct sense resistor.
  - The resistance value should be selected to maximize the input bandwidth use of the coulomb counter range, CC<sub>RANGE</sub>, as well as keeping the SCD and OCD thresholds in the available selections, and not exceed the absolute maximum ratings. The sense resistance RSNS is the threshold or input voltage divided by the current.
    - Using the normal max discharge current, RSNS = 200 mV / 10.0 A = 20 mΩ maximum.
    - However, considering the maximum SCD threshold of 200 mV and I<sub>SCD</sub> of 25 A, RSNS = 200 mV / 25 A = 8 mΩ maximum.
    - The maximum OCD threshold available is 100 mV, with the maximum current of 15 A, RSNS = 100 mV / 15.0 A = 6.7 mΩ maximum.
  - Further tolerance analysis (value tolerance, temperature variation, and so on) and PCB design margin should also be considered, so RSNS of 5 mΩ would be suitable with a 75-ppm temperature coefficient and power rating of 5 W.
  - With VSS referenced at the SRP terminal charge current creates a negative voltage on SRN. The 5 mΩ with 3 A charge current is within the absolute maximum range.
- The BQ76930 is chosen, and so the REGSRC pin needs to be powered through a source follower circuit where the FET is used to provide current for REGSRC from the battery positive terminal while reducing the voltage to a suitable value for the IC.
  - The FET also dissipates the power resulting from the load current and dropped voltage external to the IC and care should be taken to ensure the correct dissipation ratings are specified by the chosen FET.
- Configure the Current-based protection settings through PROTECT1 and PROTECT2:
  - Ideal SCD Threshold = 25 A × 5 mΩ = 125 mV.
    - However, the closest options are 111 mV (0x03) and 133 mV (0x04) providing 22.2 A and 26.6 A, respectively. Both options have the RSNS bit = 1.
    - 0x03 (22.2 A) will be used in this example.
  - The SCD delay threshold setting for a 100 μs delay is 0x01.
  - Therefore, PROTECT1 should be programmed with 0x8B.
  - Ideal OCD Threshold = 15 A × 5 mΩ = 75 mV.

- However, the closest options are 72 mV (0x0A) and 78 mV (0x0B), providing 14.4 A and 15.6 A, respectively. Both options have the RSNS bit = 1.
- 0x0A (14.4A) will be used in this example.
- The OCD delay threshold setting for a 320-ms delay is 0x05.
- Therefore, PROTECT2 should be programmed with 0x5B.

#### Note

Care should be taken when determining the setting of OV\_TRIP and UV\_TRIP as these are ADC value outputs and correlation to cell voltage also requires consideration of the ADC GAIN and ADC OFFSET registers. More specific details can be found in [Section 8.3.1.2](#).

- Configure the Voltage-based protection settings through OV\_TRIP, UV\_TRIP and PROTECT3:
  - The selected OV Threshold is 4.30 V. If ADCOFFSET is 0 and GAIN is 382, the desired threshold is 11257 or 0x2BF9.
    - Therefore, OV\_TRIP should be programmed with 0xBF.
  - The selected UV Threshold is 2.5 V. If ADCOFFSET is 0 and GAIN is 382, the desired threshold is 6545 or 0x1991.
    - Therefore, UV\_TRIP should be programmed with 0x99.
  - The selected OV Delay is 2 s and the selected UV Delay is 4 s.
    - Therefore, PROTECT3 should be programmed with 0x50.

### 9.2.3 Application Curves

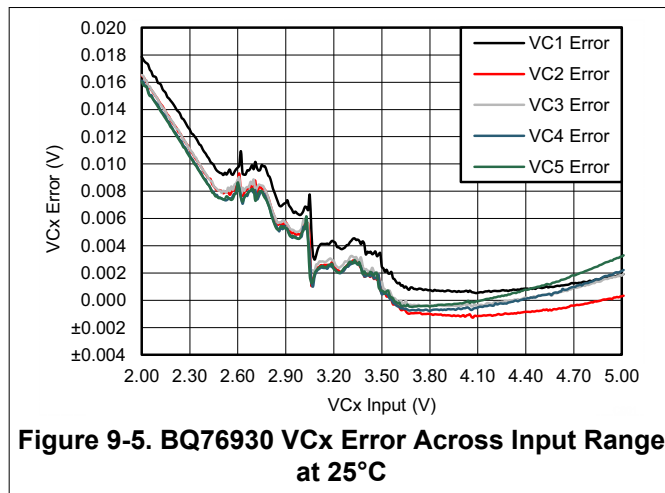

**Figure 9-5. BQ76930 VCx Error Across Input Range at 25°C**

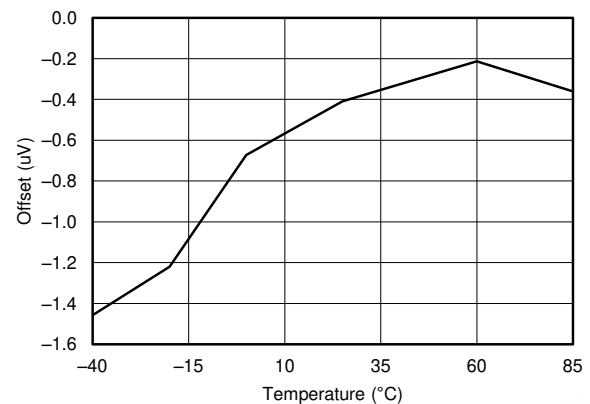

**Figure 9-6. Coulomb Counter Offset**

## 10 Power Supply Recommendations

The BQ769x0 devices are powered through the BAT and REGSRC pins but the BQ76930 and BQ76940 have additional 'Power' pins to provide the power to the entire device in the higher cell configurations.

The use of Rf and Cf connected to the BAT pin, noted in the typical application diagrams, are required to filter system transients from disturbing the device power supply. These components should be placed as close as to the IC as possible.

Additionally, for the BQ76930 and BQ76940 there are additional requirements to ensure a stable power supply to the device. The REGSRC pin is powered through a source follower circuit where the FET is used to provide current for REGSRC from the battery positive terminal while reducing the voltage to a suitable value for the IC. The FET also dissipates the power resulting from the load current and dropped voltage external to the IC and care should be taken to ensure the correct dissipation ratings are specified by the chosen FET.

The BQ76920 does not use a FET because the battery voltage is within the REGSRC range.

More information on this topic is available in the [BQ769x0 Family Top Design Considerations Application Report](#).

## 11 Layout

### 11.1 Layout Guidelines

It is strongly recommended for best measurement performance to keep high current signals from interfering with the measurement system inputs and ground.

A second key recommendation is to ensure that the BQ769x0 input filtering capacitors and power capacitors are connected to a common ground with as little parasitic resistance between the connections as possible.

### 11.2 Layout Example

Figure 11-1 shows a guideline of how to place key components compared to respective ground zones, based on the BQ76920, BQ76930, and BQ76940 EVMs.

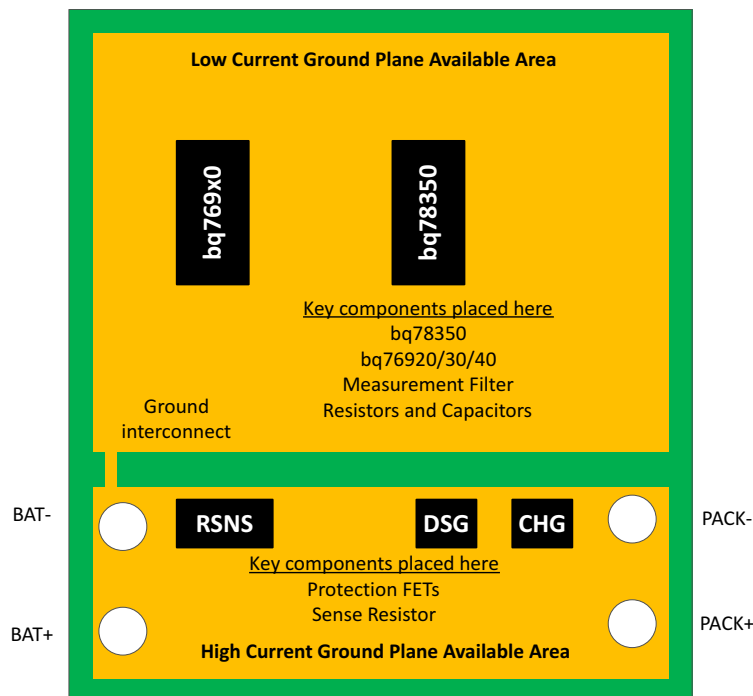

**Figure 11-1. System Component Placement Layout vs. Ground Zone Guide**

#### CAUTION

Care should be taken when placing key power pin capacitors to minimize PCB trace impedances. These impedances could result in device resets or other unexpected operations when the device is at peak power consumption.

Although not shown in the diagrams, this caution also applies to the resistor and capacitor network surrounding the current sense resistor.

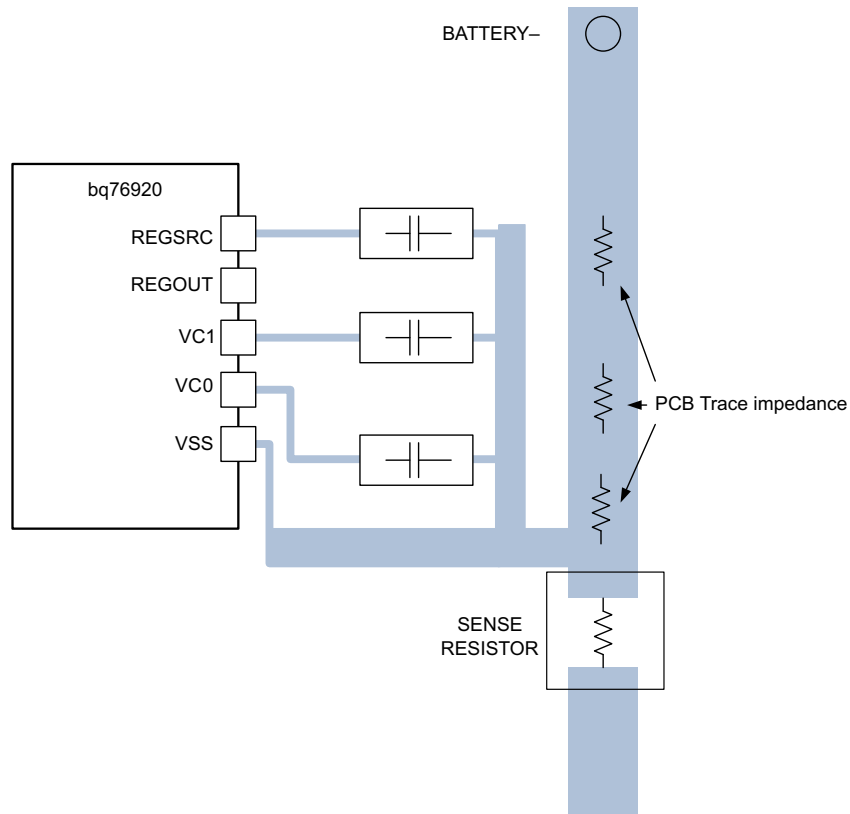

Figure 11-2. Good Layout: Input Capacitor Grounding With Low Parasitic PCB Impedance

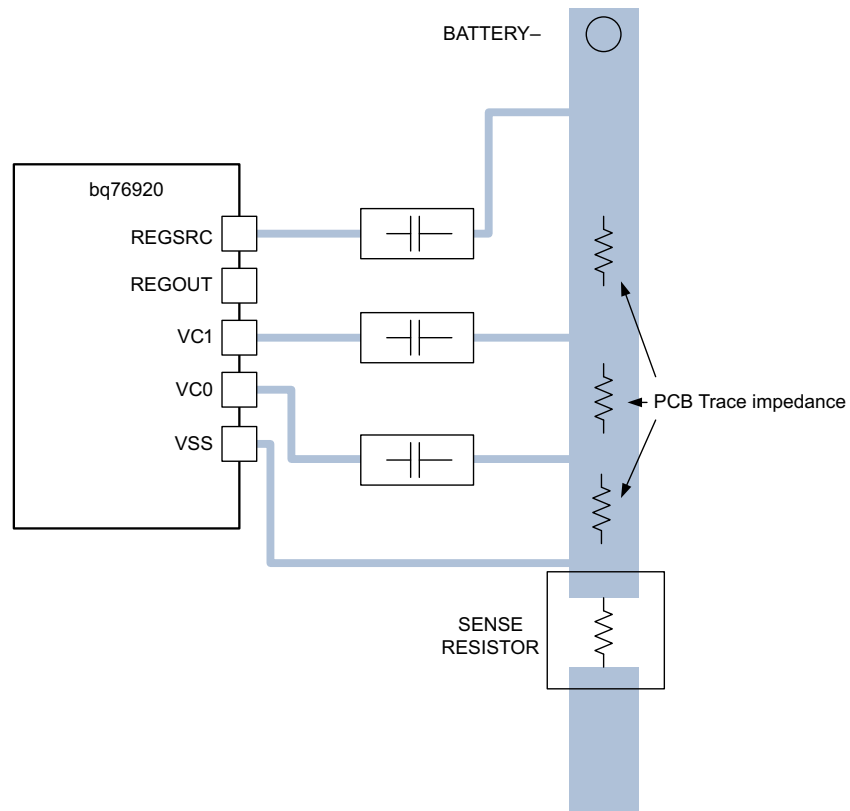

Figure 11-3. Weak Layout: Input Capacitor Grounding with High Parasitic PCB Impedance

## 12 Device and Documentation Support

### 12.1 Third-Party Products Disclaimer

TI'S PUBLICATION OF INFORMATION REGARDING THIRD-PARTY PRODUCTS OR SERVICES DOES NOT CONSTITUTE AN ENDORSEMENT REGARDING THE SUITABILITY OF SUCH PRODUCTS OR SERVICES OR A WARRANTY, REPRESENTATION OR ENDORSEMENT OF SUCH PRODUCTS OR SERVICES, EITHER ALONE OR IN COMBINATION WITH ANY TI PRODUCT OR SERVICE.

### 12.2 Documentation Support

For related documentation, see the following:

- *BQ76200 High Voltage Battery Pack Front-End Charge/Discharge High-Side NFET Driver Data Sheet* ([SLUSC16](#))
- *BQ769x0 Family Top Design Considerations Application Report* ([SLUA749](#))
- *BQ769x0 Boot Switch Alternatives Application Report* ([SLUA769](#))
- *BQ769x0 Pin Equivalent Diagrams* ([SLVA682](#))
- *BQ769x0 BMS Configurations for Cordless Appliances* ([SLUA810](#))
- *Fault Monitoring for High-Availability Systems Using the BQ769x0* ([SLUA805](#))

### 12.3 Related Links

The table below lists quick access links. Categories include technical documents, support and community resources, tools and software, and quick access to sample or buy.

**Table 12-1. Related Links**

PARTS	PRODUCT FOLDER	SAMPLE & BUY	TECHNICAL DOCUMENTS	TOOLS & SOFTWARE	SUPPORT & COMMUNITY
BQ76920	<a href="#">Click here</a>	<a href="#">Click here</a>	<a href="#">Click here</a>	<a href="#">Click here</a>	<a href="#">Click here</a>
BQ76930	<a href="#">Click here</a>	<a href="#">Click here</a>	<a href="#">Click here</a>	<a href="#">Click here</a>	<a href="#">Click here</a>
BQ76940	<a href="#">Click here</a>	<a href="#">Click here</a>	<a href="#">Click here</a>	<a href="#">Click here</a>	<a href="#">Click here</a>

### 12.4 Receiving Notification of Documentation Updates

To receive notification of documentation updates, navigate to the device product folder on ti.com. In the upper right corner, click on *Alert me* to register and receive a weekly digest of any product information that has changed. For change details, review the revision history included in any revised document.

### 12.5 Trademarks

All trademarks are the property of their respective owners.

## 13 Mechanical, Packaging, and Orderable Information

The following pages include mechanical, packaging, and orderable information. This information is the most current data available for the designated devices. This data is subject to change without notice and revision of this document. For browser-based versions of this data sheet, refer to the left-hand navigation.

**PACKAGING INFORMATION**

Orderable Device	Status (1)	Package Type	Package Drawing	Pins	Package Qty	Eco Plan (2)	Lead finish/ Ball material (6)	MSL Peak Temp (3)	Op Temp (°C)	Device Marking (4/5)	Samples
BQ7692000PW	ACTIVE	TSSOP	PW	20	70	RoHS & Green	NIPDAU	Level-2-260C-1 YEAR	-40 to 85	BQ7692000	<a href="#">Samples</a>
BQ7692000PWR	ACTIVE	TSSOP	PW	20	2000	RoHS & Green	NIPDAU	Level-2-260C-1 YEAR	-40 to 85	BQ7692000	<a href="#">Samples</a>
BQ7692003PW	ACTIVE	TSSOP	PW	20	70	RoHS & Green	NIPDAU	Level-2-260C-1 YEAR	-40 to 85	BQ7692003	<a href="#">Samples</a>
BQ7692003PWR	ACTIVE	TSSOP	PW	20	2000	RoHS & Green	Call TI   NIPDAU	Level-2-260C-1 YEAR	-40 to 85	BQ7692003	<a href="#">Samples</a>
BQ7692006PW	ACTIVE	TSSOP	PW	20	70	RoHS & Green	NIPDAU	Level-2-260C-1 YEAR	-40 to 85	BQ7692006	<a href="#">Samples</a>
BQ7692006PWR	ACTIVE	TSSOP	PW	20	2000	RoHS & Green	NIPDAU	Level-2-260C-1 YEAR	-40 to 85	BQ7692006	<a href="#">Samples</a>
BQ7693000DBT	ACTIVE	TSSOP	DBT	30	60	RoHS & Green	NIPDAU	Level-2-260C-1 YEAR	-40 to 85	BQ7693000	<a href="#">Samples</a>
BQ7693000DBTR	ACTIVE	TSSOP	DBT	30	2000	RoHS & Green	NIPDAU	Level-2-260C-1 YEAR	-40 to 85	BQ7693000	<a href="#">Samples</a>
BQ7693001DBT	ACTIVE	TSSOP	DBT	30	60	RoHS & Green	NIPDAU	Level-2-260C-1 YEAR	-40 to 85	BQ7693001	<a href="#">Samples</a>
BQ7693001DBTR	ACTIVE	TSSOP	DBT	30	2000	RoHS & Green	NIPDAU	Level-2-260C-1 YEAR	-40 to 85	BQ7693001	<a href="#">Samples</a>
BQ7693002DBT	ACTIVE	TSSOP	DBT	30	60	RoHS & Green	NIPDAU	Level-2-260C-1 YEAR	-40 to 85	BQ7693002	<a href="#">Samples</a>
BQ7693002DBTR	ACTIVE	TSSOP	DBT	30	2000	RoHS & Green	NIPDAU	Level-2-260C-1 YEAR	-40 to 85	BQ7693002	<a href="#">Samples</a>
BQ7693003DBT	ACTIVE	TSSOP	DBT	30	60	RoHS & Green	NIPDAU	Level-2-260C-1 YEAR	-40 to 85	BQ7693003	<a href="#">Samples</a>
BQ7693003DBTR	ACTIVE	TSSOP	DBT	30	2000	RoHS & Green	NIPDAU	Level-2-260C-1 YEAR	-40 to 85	BQ7693003	<a href="#">Samples</a>
BQ7693006DBT	ACTIVE	TSSOP	DBT	30	60	RoHS & Green	NIPDAU	Level-2-260C-1 YEAR	-40 to 85	BQ7693006	<a href="#">Samples</a>
BQ7693006DBTR	ACTIVE	TSSOP	DBT	30	2000	RoHS & Green	NIPDAU	Level-2-260C-1 YEAR	-40 to 85	BQ7693006	<a href="#">Samples</a>
BQ7693007DBT	ACTIVE	TSSOP	DBT	30	60	RoHS & Green	NIPDAU	Level-2-260C-1 YEAR	-40 to 85	BQ7693007	<a href="#">Samples</a>
BQ7693007DBTR	ACTIVE	TSSOP	DBT	30	2000	RoHS & Green	NIPDAU	Level-2-260C-1 YEAR	-40 to 85	BQ7693007	<a href="#">Samples</a>
BQ7694000DBT	ACTIVE	TSSOP	DBT	44	40	RoHS & Green	NIPDAU	Level-2-260C-1 YEAR	-40 to 85	BQ7694000	<a href="#">Samples</a>
BQ7694000DBTR	ACTIVE	TSSOP	DBT	44	2000	RoHS & Green	NIPDAU	Level-2-260C-1 YEAR	-40 to 85	BQ7694000	<a href="#">Samples</a>

Orderable Device	Status (1)	Package Type	Package Drawing	Pins	Package Qty	Eco Plan (2)	Lead finish/ Ball material (6)	MSL Peak Temp (3)	Op Temp (°C)	Device Marking (4/5)	Samples
BQ7694001DBT	ACTIVE	TSSOP	DBT	44	40	RoHS & Green	NIPDAU	Level-2-260C-1 YEAR	-40 to 85	BQ7694001	<a href="#">Samples</a>
BQ7694001DBTR	ACTIVE	TSSOP	DBT	44	2000	RoHS & Green	NIPDAU	Level-2-260C-1 YEAR	-40 to 85	BQ7694001	<a href="#">Samples</a>
BQ7694002DBT	ACTIVE	TSSOP	DBT	44	40	RoHS & Green	NIPDAU	Level-2-260C-1 YEAR	-40 to 85	BQ7694002	<a href="#">Samples</a>
BQ7694002DBTR	ACTIVE	TSSOP	DBT	44	2000	RoHS & Green	NIPDAU	Level-2-260C-1 YEAR	-40 to 85	BQ7694002	<a href="#">Samples</a>
BQ7694003DBT	ACTIVE	TSSOP	DBT	44	40	RoHS & Green	NIPDAU	Level-2-260C-1 YEAR	-40 to 85	BQ7694003	<a href="#">Samples</a>
BQ7694003DBTR	ACTIVE	TSSOP	DBT	44	2000	RoHS & Green	NIPDAU	Level-2-260C-1 YEAR	-40 to 85	BQ7694003	<a href="#">Samples</a>
BQ7694006DBT	ACTIVE	TSSOP	DBT	44	40	RoHS & Green	NIPDAU	Level-2-260C-1 YEAR	-40 to 85	BQ7694006	<a href="#">Samples</a>
BQ7694006DBTR	ACTIVE	TSSOP	DBT	44	2000	RoHS & Green	NIPDAU	Level-2-260C-1 YEAR	-40 to 85	BQ7694006	<a href="#">Samples</a>

(1) The marketing status values are defined as follows:

**ACTIVE:** Product device recommended for new designs.

**LIFEBUY:** TI has announced that the device will be discontinued, and a lifetime-buy period is in effect.

**NRND:** Not recommended for new designs. Device is in production to support existing customers, but TI does not recommend using this part in a new design.

**PREVIEW:** Device has been announced but is not in production. Samples may or may not be available.

**OBSOLETE:** TI has discontinued the production of the device.

(2) **RoHS:** TI defines "RoHS" to mean semiconductor products that are compliant with the current EU RoHS requirements for all 10 RoHS substances, including the requirement that RoHS substance do not exceed 0.1% by weight in homogeneous materials. Where designed to be soldered at high temperatures, "RoHS" products are suitable for use in specified lead-free processes. TI may reference these types of products as "Pb-Free".

**RoHS Exempt:** TI defines "RoHS Exempt" to mean products that contain lead but are compliant with EU RoHS pursuant to a specific EU RoHS exemption.

**Green:** TI defines "Green" to mean the content of Chlorine (Cl) and Bromine (Br) based flame retardants meet JS709B low halogen requirements of <=1000ppm threshold. Antimony trioxide based flame retardants must also meet the <=1000ppm threshold requirement.

(3) MSL, Peak Temp. - The Moisture Sensitivity Level rating according to the JEDEC industry standard classifications, and peak solder temperature.

(4) There may be additional marking, which relates to the logo, the lot trace code information, or the environmental category on the device.

(5) Multiple Device Markings will be inside parentheses. Only one Device Marking contained in parentheses and separated by a "~" will appear on a device. If a line is indented then it is a continuation of the previous line and the two combined represent the entire Device Marking for that device.

<sup>(6)</sup> Lead finish/Ball material - Orderable Devices may have multiple material finish options. Finish options are separated by a vertical ruled line. Lead finish/Ball material values may wrap to two lines if the finish value exceeds the maximum column width.

**Important Information and Disclaimer:**The information provided on this page represents TI's knowledge and belief as of the date that it is provided. TI bases its knowledge and belief on information provided by third parties, and makes no representation or warranty as to the accuracy of such information. Efforts are underway to better integrate information from third parties. TI has taken and continues to take reasonable steps to provide representative and accurate information but may not have conducted destructive testing or chemical analysis on incoming materials and chemicals. TI and TI suppliers consider certain information to be proprietary, and thus CAS numbers and other limited information may not be available for release.

In no event shall TI's liability arising out of such information exceed the total purchase price of the TI part(s) at issue in this document sold by TI to Customer on an annual basis.

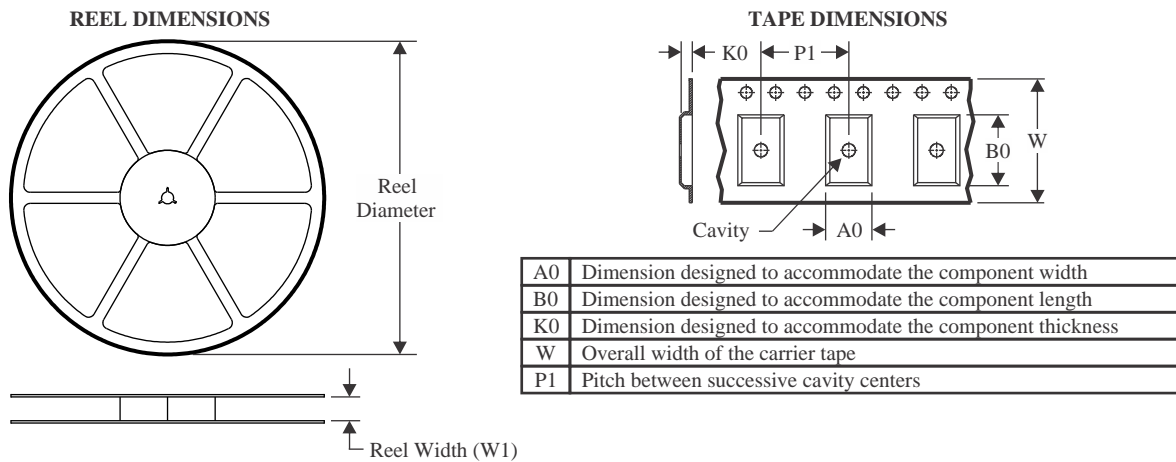
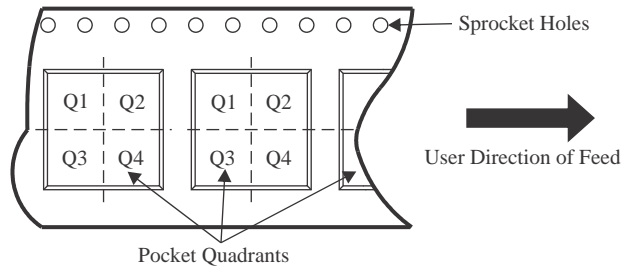
**TAPE AND REEL INFORMATION**

**QUADRANT ASSIGNMENTS FOR PIN 1 ORIENTATION IN TAPE**

\*All dimensions are nominal

Device	Package Type	Package Drawing	Pins	SPQ	Reel Diameter (mm)	Reel Width W1 (mm)	A0 (mm)	B0 (mm)	K0 (mm)	P1 (mm)	W (mm)	Pin1 Quadrant
BQ7692000PWR	TSSOP	PW	20	2000	330.0	16.4	6.95	7.1	1.6	8.0	16.0	Q1
BQ7692003PWR	TSSOP	PW	20	2000	330.0	16.4	6.95	7.1	1.6	8.0	16.0	Q1
BQ7692006PWR	TSSOP	PW	20	2000	330.0	16.4	6.95	7.1	1.6	8.0	16.0	Q1
BQ7693000DBTR	TSSOP	DBT	30	2000	330.0	16.4	6.95	8.3	1.6	8.0	16.0	Q1
BQ7693001DBTR	TSSOP	DBT	30	2000	330.0	16.4	6.95	8.3	1.6	8.0	16.0	Q1
BQ7693002DBTR	TSSOP	DBT	30	2000	330.0	16.4	6.95	8.3	1.6	8.0	16.0	Q1
BQ7693003DBTR	TSSOP	DBT	30	2000	330.0	16.4	6.95	8.3	1.6	8.0	16.0	Q1
BQ7693006DBTR	TSSOP	DBT	30	2000	330.0	16.4	6.95	8.3	1.6	8.0	16.0	Q1
BQ7693007DBTR	TSSOP	DBT	30	2000	330.0	16.4	6.95	8.3	1.6	8.0	16.0	Q1
BQ7694000DBTR	TSSOP	DBT	44	2000	330.0	24.4	6.8	11.7	1.6	12.0	24.0	Q1
BQ7694001DBTR	TSSOP	DBT	44	2000	330.0	24.4	6.8	11.7	1.6	12.0	24.0	Q1
BQ7694002DBTR	TSSOP	DBT	44	2000	330.0	24.4	6.8	11.7	1.6	12.0	24.0	Q1
BQ7694003DBTR	TSSOP	DBT	44	2000	330.0	24.4	6.8	11.7	1.6	12.0	24.0	Q1
BQ7694006DBTR	TSSOP	DBT	44	2000	330.0	24.4	6.8	11.7	1.6	12.0	24.0	Q1

## TAPE AND REEL BOX DIMENSIONS



\*All dimensions are nominal

Device	Package Type	Package Drawing	Pins	SPQ	Length (mm)	Width (mm)	Height (mm)
BQ7692000PWR	TSSOP	PW	20	2000	350.0	350.0	43.0
BQ7692003PWR	TSSOP	PW	20	2000	350.0	350.0	43.0
BQ7692006PWR	TSSOP	PW	20	2000	350.0	350.0	43.0
BQ7693000DBTR	TSSOP	DBT	30	2000	350.0	350.0	43.0
BQ7693001DBTR	TSSOP	DBT	30	2000	350.0	350.0	43.0
BQ7693002DBTR	TSSOP	DBT	30	2000	350.0	350.0	43.0
BQ7693003DBTR	TSSOP	DBT	30	2000	350.0	350.0	43.0
BQ7693006DBTR	TSSOP	DBT	30	2000	350.0	350.0	43.0
BQ7693007DBTR	TSSOP	DBT	30	2000	350.0	350.0	43.0
BQ7694000DBTR	TSSOP	DBT	44	2000	350.0	350.0	43.0
BQ7694001DBTR	TSSOP	DBT	44	2000	350.0	350.0	43.0
BQ7694002DBTR	TSSOP	DBT	44	2000	350.0	350.0	43.0
BQ7694003DBTR	TSSOP	DBT	44	2000	350.0	350.0	43.0
BQ7694006DBTR	TSSOP	DBT	44	2000	350.0	350.0	43.0

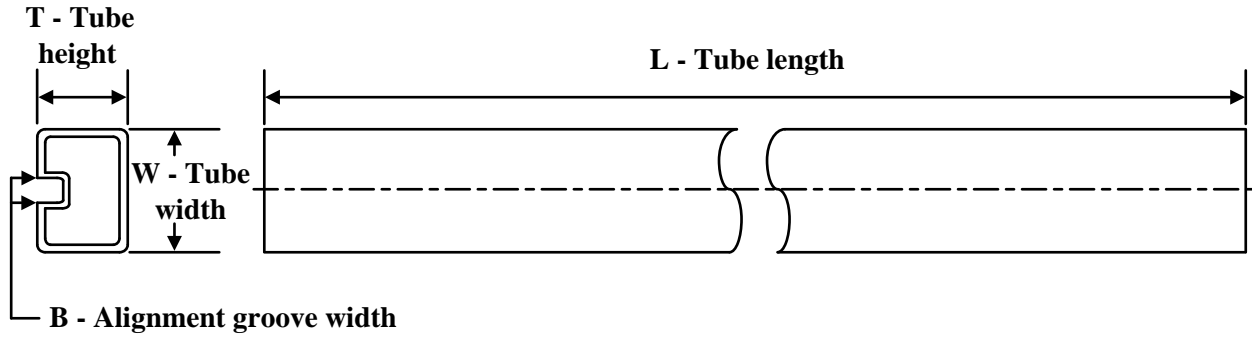
**TUBE**

\*All dimensions are nominal

Device	Package Name	Package Type	Pins	SPQ	L (mm)	W (mm)	T (μm)	B (mm)
BQ7692000PW	PW	TSSOP	20	70	530	10.2	3600	3.5
BQ7692003PW	PW	TSSOP	20	70	530	10.2	3600	3.5
BQ7692006PW	PW	TSSOP	20	70	530	10.2	3600	3.5
BQ7693000DBT	DBT	TSSOP	30	60	530	10.2	3600	3.5
BQ7693001DBT	DBT	TSSOP	30	60	530	10.2	3600	3.5
BQ7693002DBT	DBT	TSSOP	30	60	530	10.2	3600	3.5
BQ7693003DBT	DBT	TSSOP	30	60	530	10.2	3600	3.5
BQ7693006DBT	DBT	TSSOP	30	60	530	10.2	3600	3.5
BQ7693007DBT	DBT	TSSOP	30	60	530	10.2	3600	3.5
BQ7694000DBT	DBT	TSSOP	44	40	530	10.2	3600	3.5
BQ7694001DBT	DBT	TSSOP	44	40	530	10.2	3600	3.5
BQ7694002DBT	DBT	TSSOP	44	40	530	10.2	3600	3.5
BQ7694003DBT	DBT	TSSOP	44	40	530	10.2	3600	3.5
BQ7694006DBT	DBT	TSSOP	44	40	530	10.2	3600	3.5

PW0020A

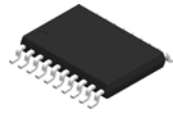

# PACKAGE OUTLINE

TSSOP - 1.2 mm max height

SMALL OUTLINE PACKAGE

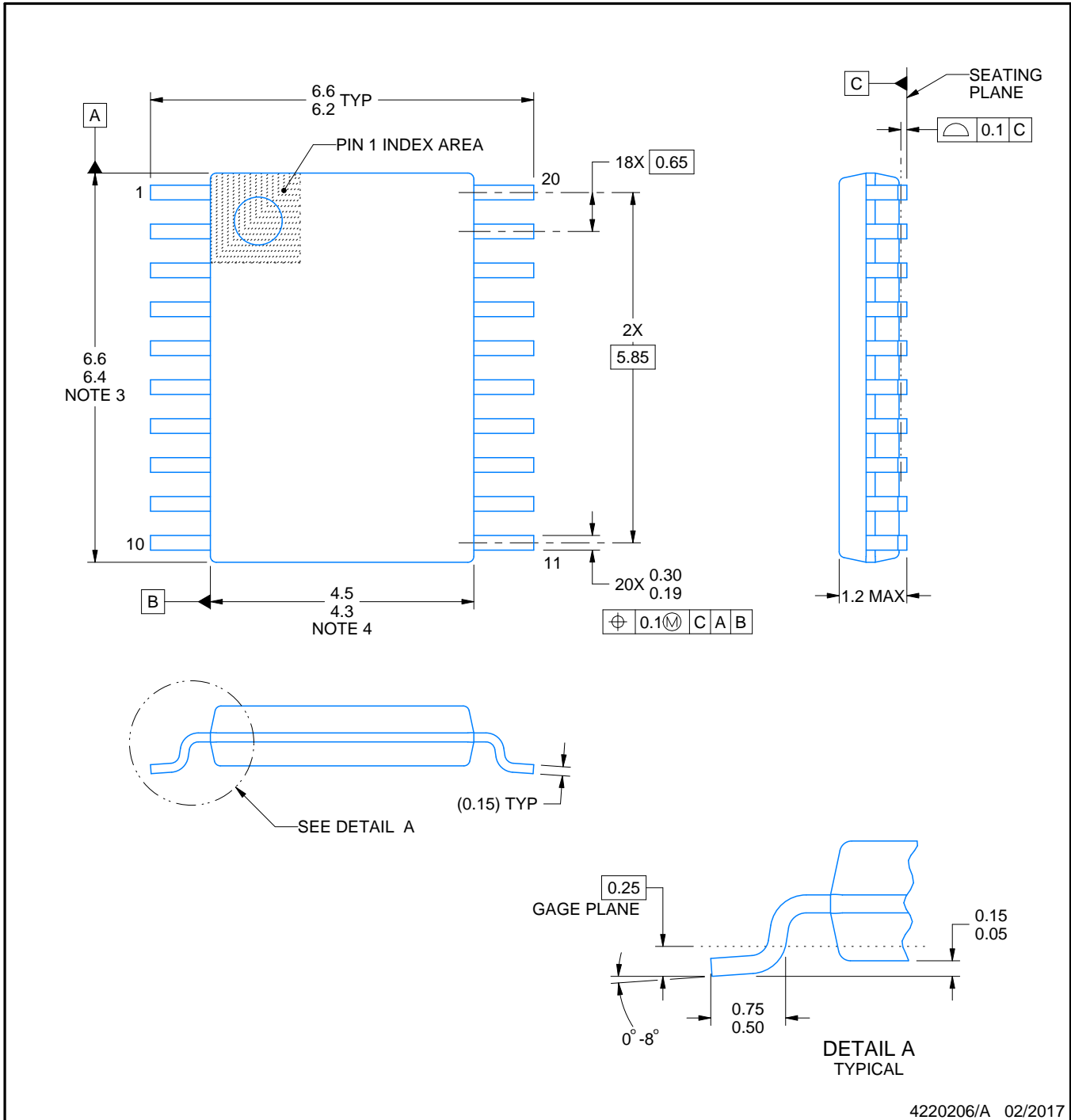

4220206/A 02/2017

NOTES:

- All linear dimensions are in millimeters. Any dimensions in parenthesis are for reference only. Dimensioning and tolerancing per ASME Y14.5M.
- This drawing is subject to change without notice.
- This dimension does not include mold flash, protrusions, or gate burrs. Mold flash, protrusions, or gate burrs shall not exceed 0.15 mm per side.
- This dimension does not include interlead flash. Interlead flash shall not exceed 0.25 mm per side.
- Reference JEDEC registration MO-153.

# EXAMPLE BOARD LAYOUT

PW0020A

TSSOP - 1.2 mm max height

SMALL OUTLINE PACKAGE

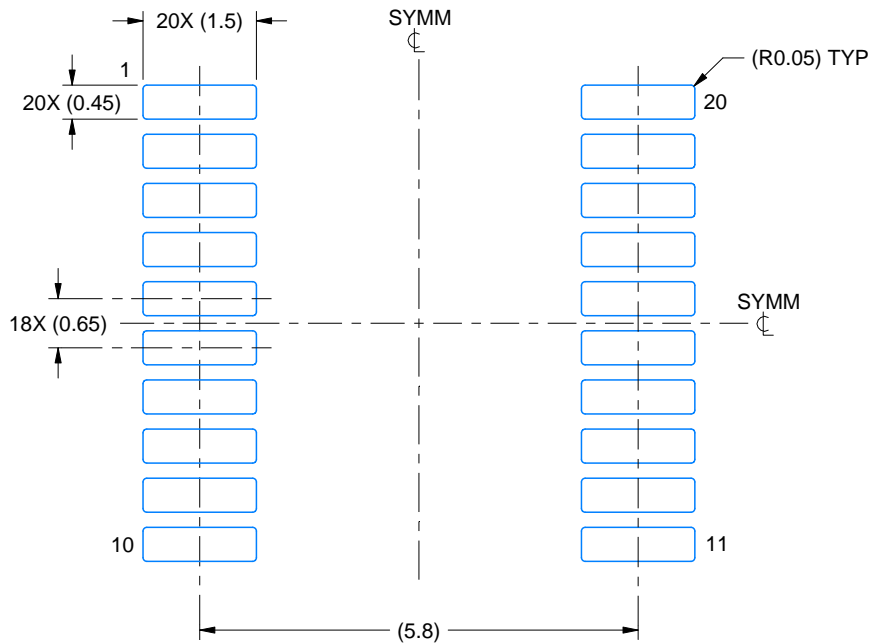

LAND PATTERN EXAMPLE  
EXPOSED METAL SHOWN  
SCALE: 10X

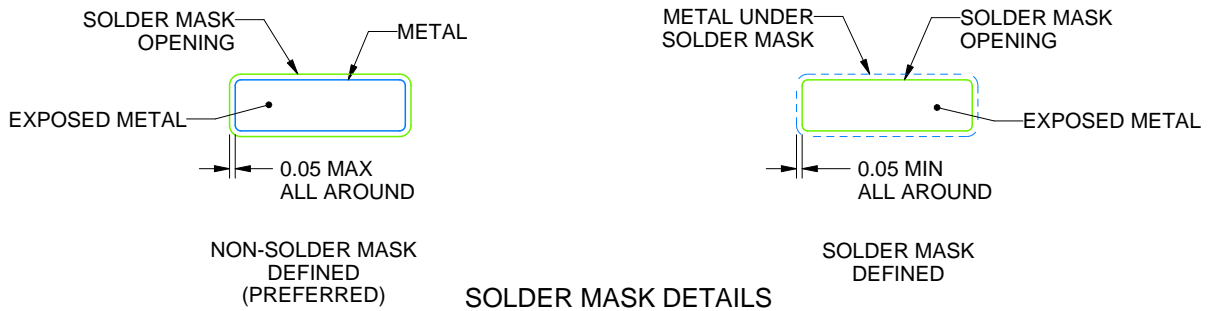

4220206/A 02/2017

NOTES: (continued)

- 6. Publication IPC-7351 may have alternate designs.
- 7. Solder mask tolerances between and around signal pads can vary based on board fabrication site.

# EXAMPLE STENCIL DESIGN

PW0020A

TSSOP - 1.2 mm max height

SMALL OUTLINE PACKAGE

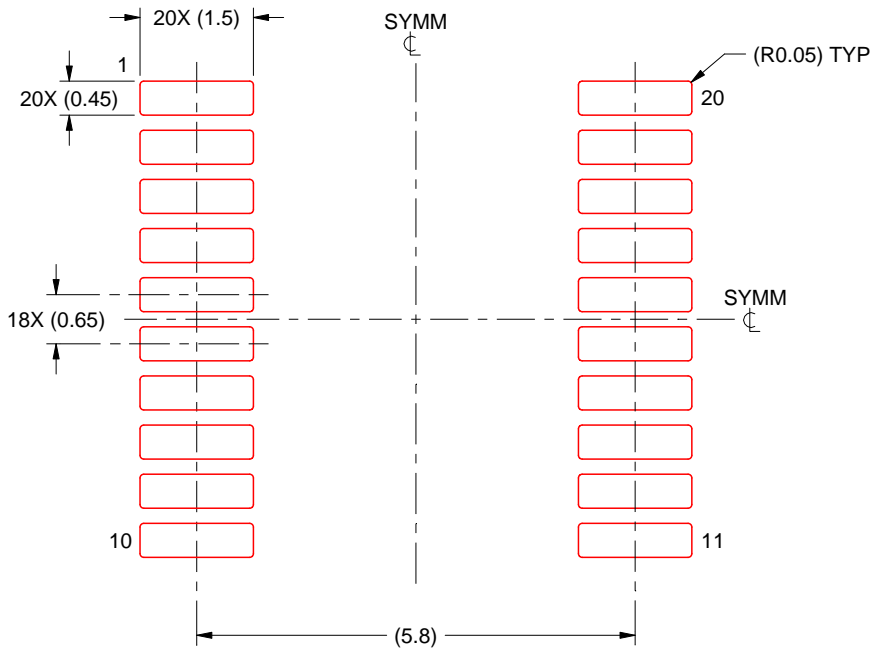

SOLDER PASTE EXAMPLE  
BASED ON 0.125 mm THICK STENCIL  
SCALE: 10X

4220206/A 02/2017

NOTES: (continued)

8. Laser cutting apertures with trapezoidal walls and rounded corners may offer better paste release. IPC-7525 may have alternate design recommendations.
9. Board assembly site may have different recommendations for stencil design.

PW (R-PDSO-G20)

PLASTIC SMALL OUTLINE

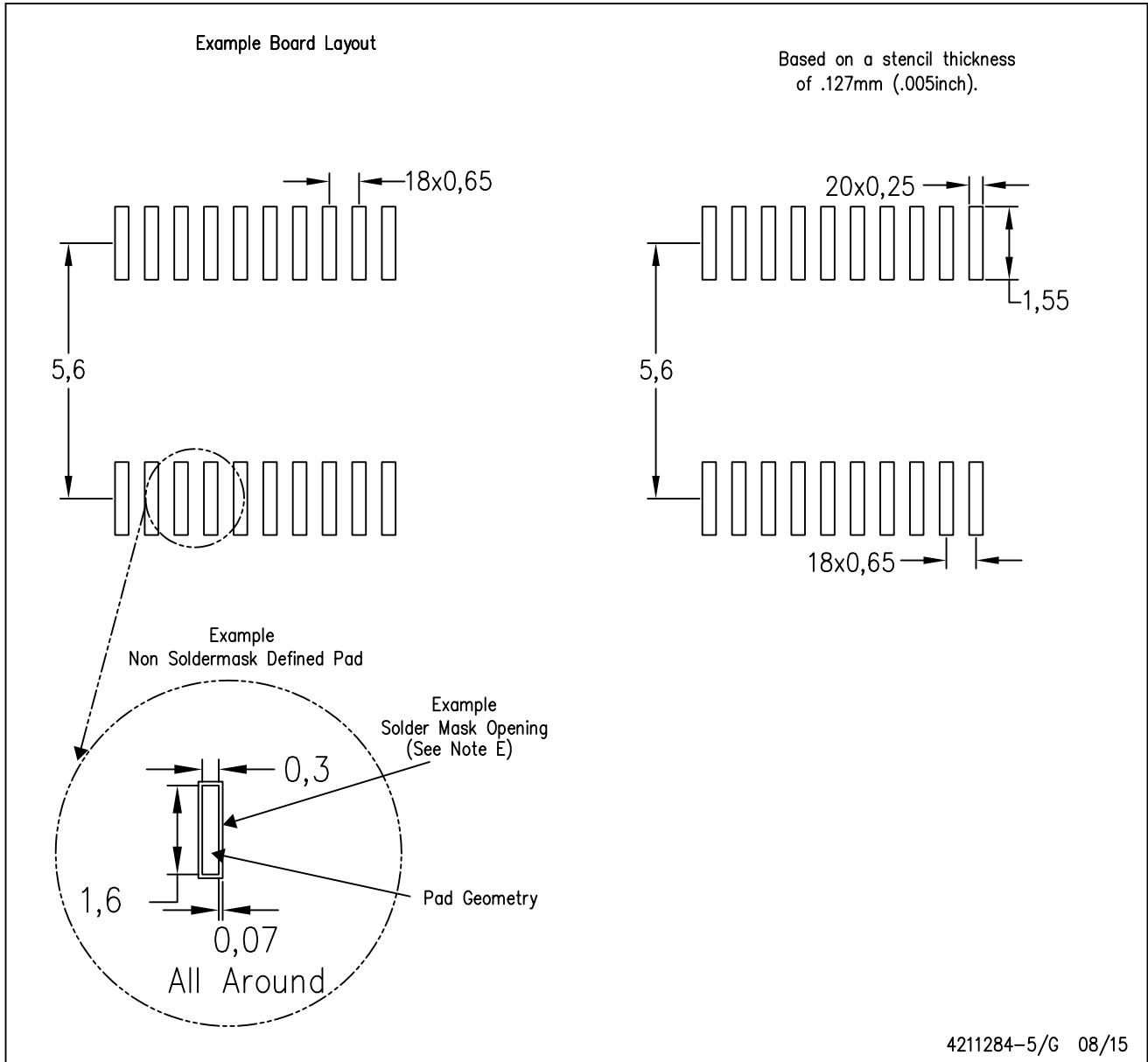

- NOTES:
- A. All linear dimensions are in millimeters.
  - B. This drawing is subject to change without notice.
  - C. Publication IPC-7351 is recommended for alternate design.
  - D. Laser cutting apertures with trapezoidal walls and also rounding corners will offer better paste release. Customers should contact their board assembly site for stencil design recommendations. Refer to IPC-7525 for other stencil recommendations.
  - E. Customers should contact their board fabrication site for solder mask tolerances between and around signal pads.



# EXAMPLE BOARD LAYOUT

DBT0030A

TSSOP - 1.2 mm max height

SMALL OUTLINE PACKAGE

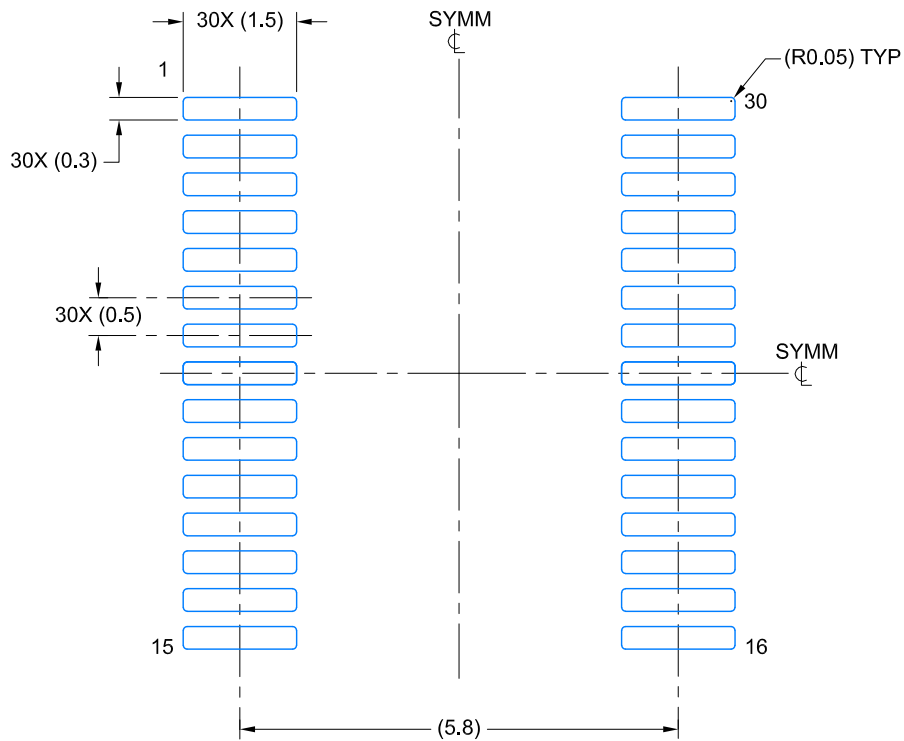

LAND PATTERN EXAMPLE  
EXPOSED METAL SHOWN  
SCALE: 10X

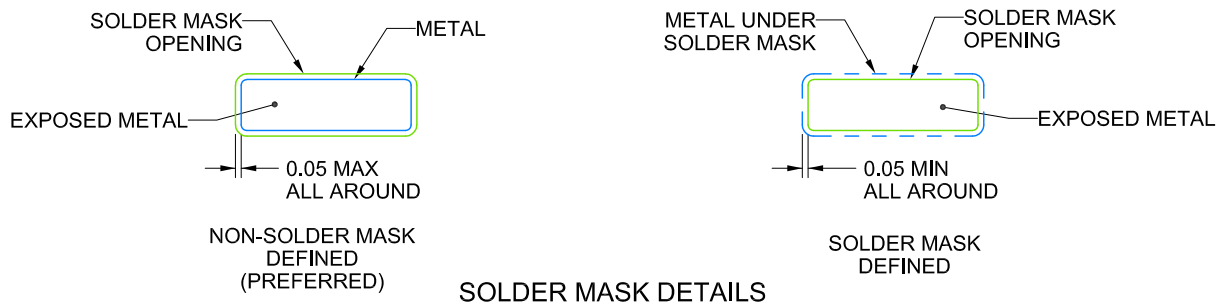

SOLDER MASK DETAILS

4220214/B 09/2021

NOTES: (continued)

6. Publication IPC-7351 may have alternate designs.

7. Solder mask tolerances between and around signal pads can vary based on board fabrication site.

# EXAMPLE STENCIL DESIGN

DBT0030A

TSSOP - 1.2 mm max height

SMALL OUTLINE PACKAGE

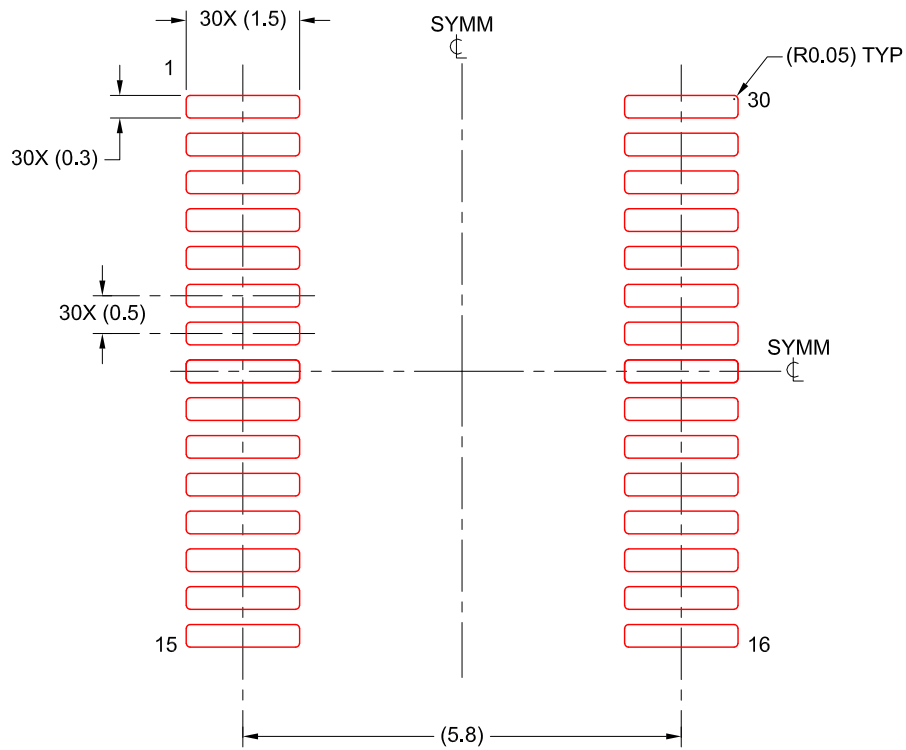

SOLDER PASTE EXAMPLE  
BASED ON 0.125 mm THICK STENCIL  
SCALE: 10X

4220214/B 09/2021

NOTES: (continued)

8. Laser cutting apertures with trapezoidal walls and rounded corners may offer better paste release. IPC-7525 may have alternate design recommendations.
9. Board assembly site may have different recommendations for stencil design.

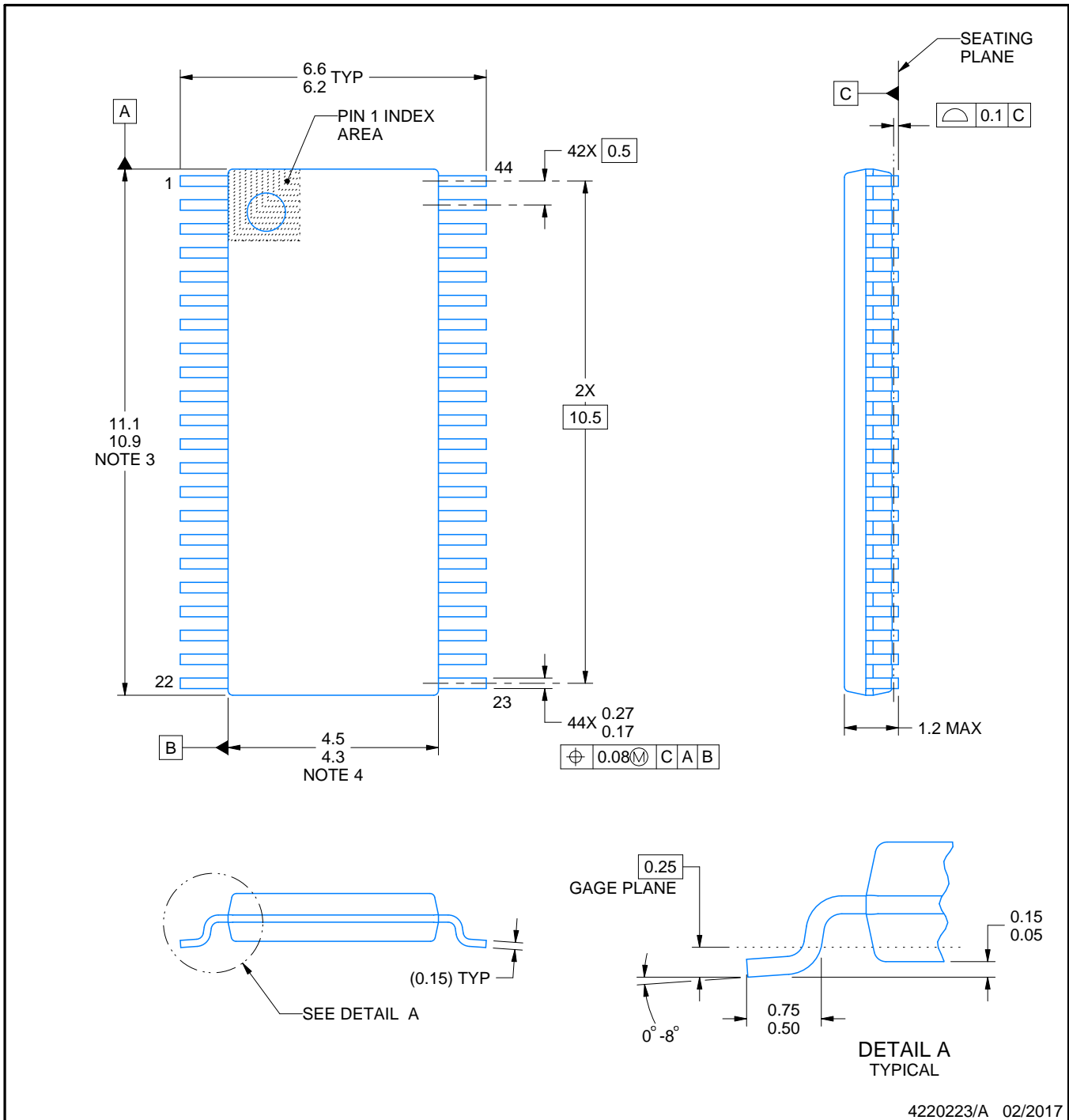
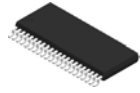

4220223/A 02/2017

NOTES:

1. All linear dimensions are in millimeters. Any dimensions in parenthesis are for reference only. Dimensioning and tolerancing per ASME Y14.5M.
2. This drawing is subject to change without notice.
3. This dimension does not include mold flash, protrusions, or gate burrs. Mold flash, protrusions, or gate burrs shall not exceed 0.15 mm per side.
4. This dimension does not include interlead flash. Interlead flash shall not exceed 0.25 mm per side.

# EXAMPLE BOARD LAYOUT

DBT0044A

TSSOP - 1.2 mm max height

SMALL OUTLINE PACKAGE

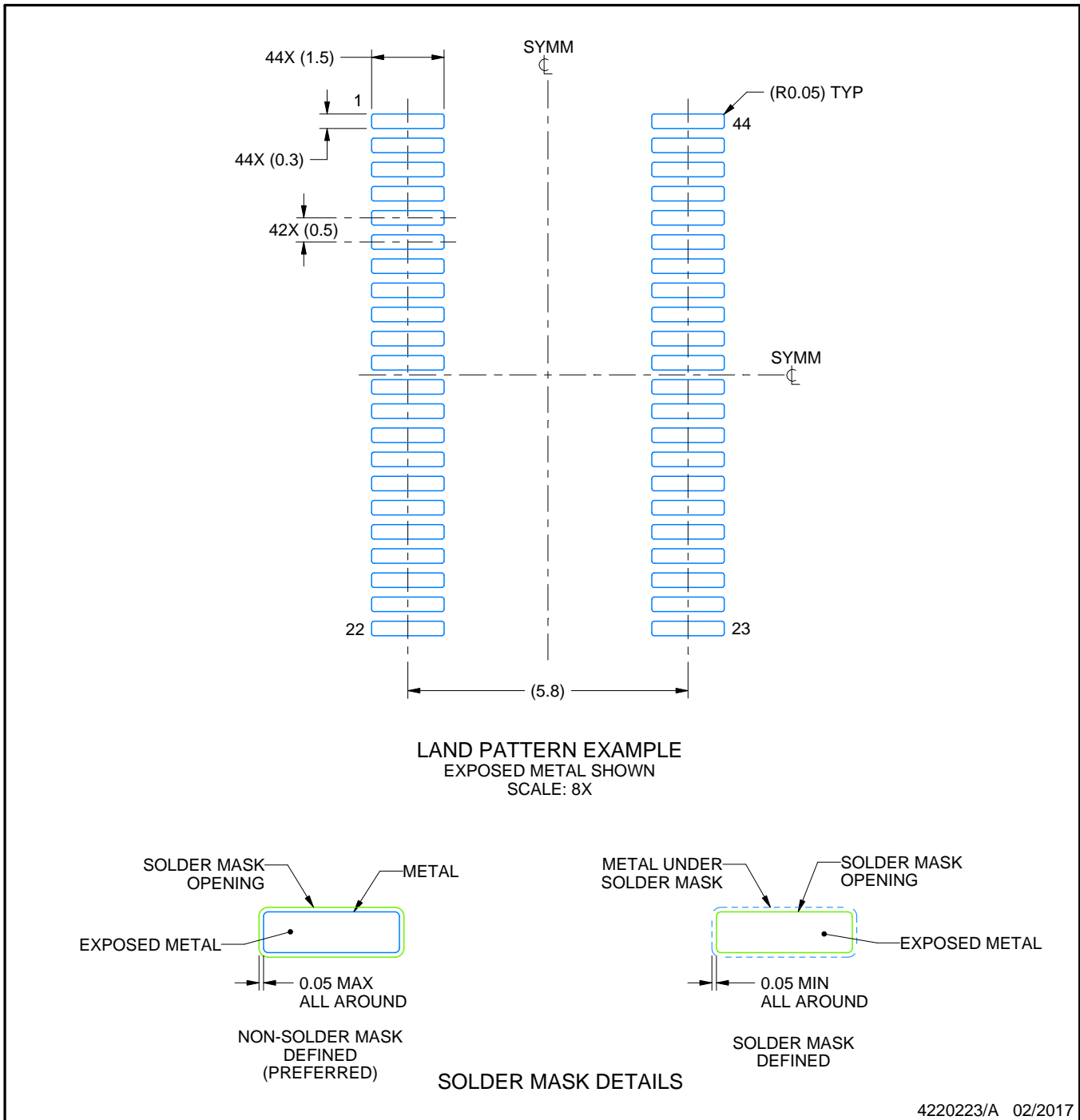

NOTES: (continued)

- Publication IPC-7351 may have alternate designs.
- Solder mask tolerances between and around signal pads can vary based on board fabrication site.

# EXAMPLE STENCIL DESIGN

DBT0044A

TSSOP - 1.2 mm max height

SMALL OUTLINE PACKAGE

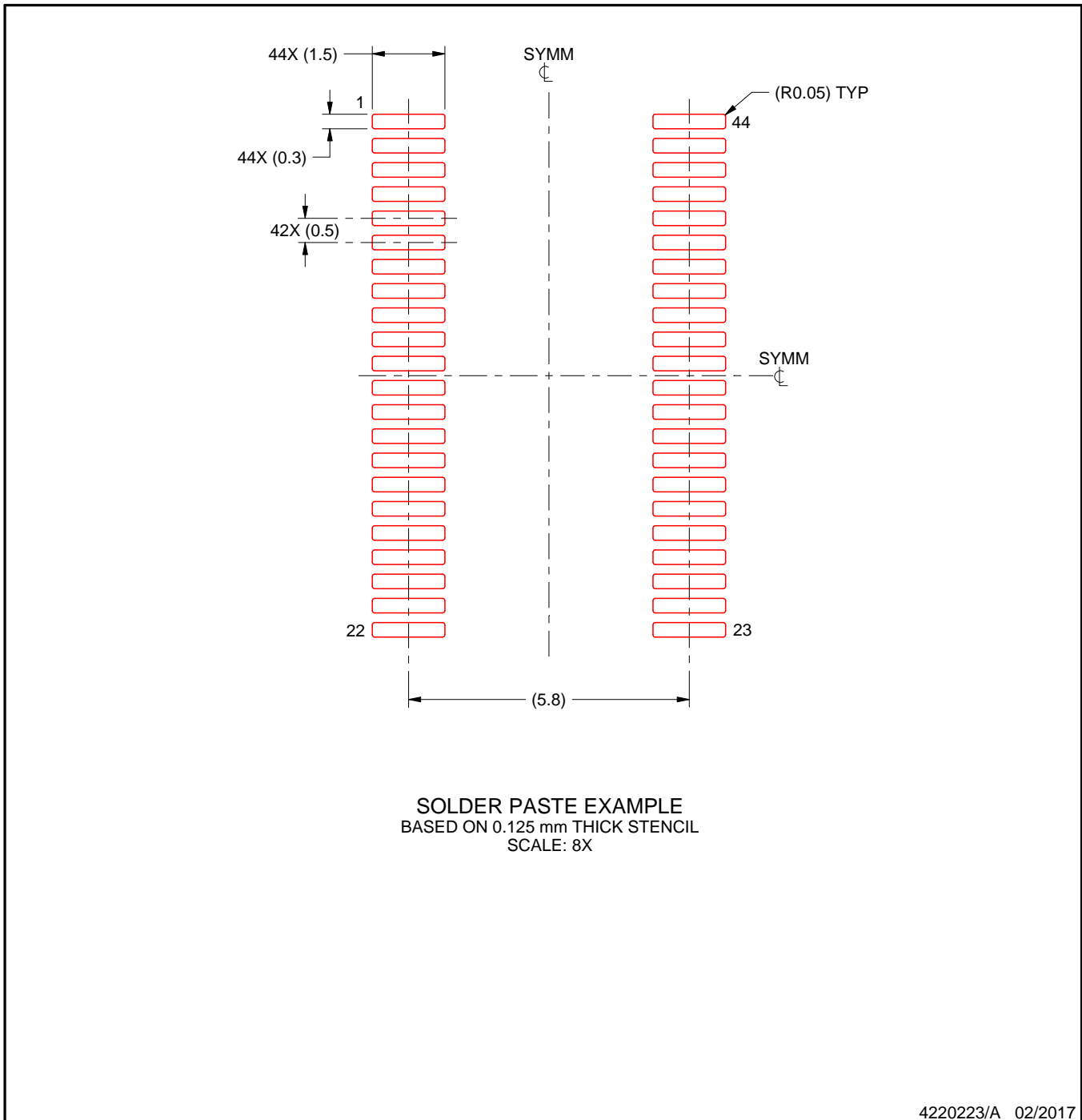

NOTES: (continued)

7. Laser cutting apertures with trapezoidal walls and rounded corners may offer better paste release. IPC-7525 may have alternate design recommendations.
8. Board assembly site may have different recommendations for stencil design.

## IMPORTANT NOTICE AND DISCLAIMER

TI PROVIDES TECHNICAL AND RELIABILITY DATA (INCLUDING DATA SHEETS), DESIGN RESOURCES (INCLUDING REFERENCE DESIGNS), APPLICATION OR OTHER DESIGN ADVICE, WEB TOOLS, SAFETY INFORMATION, AND OTHER RESOURCES "AS IS" AND WITH ALL FAULTS, AND DISCLAIMS ALL WARRANTIES, EXPRESS AND IMPLIED, INCLUDING WITHOUT LIMITATION ANY IMPLIED WARRANTIES OF MERCHANTABILITY, FITNESS FOR A PARTICULAR PURPOSE OR NON-INFRINGEMENT OF THIRD PARTY INTELLECTUAL PROPERTY RIGHTS.

These resources are intended for skilled developers designing with TI products. You are solely responsible for (1) selecting the appropriate TI products for your application, (2) designing, validating and testing your application, and (3) ensuring your application meets applicable standards, and any other safety, security, regulatory or other requirements.

These resources are subject to change without notice. TI grants you permission to use these resources only for development of an application that uses the TI products described in the resource. Other reproduction and display of these resources is prohibited. No license is granted to any other TI intellectual property right or to any third party intellectual property right. TI disclaims responsibility for, and you will fully indemnify TI and its representatives against, any claims, damages, costs, losses, and liabilities arising out of your use of these resources.

TI's products are provided subject to [TI's Terms of Sale](#) or other applicable terms available either on [ti.com](https://www.ti.com) or provided in conjunction with such TI products. TI's provision of these resources does not expand or otherwise alter TI's applicable warranties or warranty disclaimers for TI products.

TI objects to and rejects any additional or different terms you may have proposed.

Mailing Address: Texas Instruments, Post Office Box 655303, Dallas, Texas 75265  
Copyright © 2023, Texas Instruments Incorporated

## Looking for pricing, stock, or lifecycle information?

Click below to explore more details on WIN SOURCE:

 [View BQ7693001DBTR on WIN SOURCE](#)

 [Texas Instruments](#) Information

## Optimize Your Supply Chain with WIN SOURCE Solutions

-  Global Sourcing Solution
-  Obsolete Management
-  Cost Control Management
-  Shortage Management
-  Alternative Solution
-  Excess Inventory Management