



**THE DATASHEET OF  
CY14B256LA-SP45XIT**





**Please note that Cypress is an Infineon Technologies Company.**

The document following this cover page is marked as “Cypress” document as this is the company that originally developed the product. Please note that Infineon will continue to offer the product to new and existing customers as part of the Infineon product portfolio.

**Continuity of document content**

The fact that Infineon offers the following product as part of the Infineon product portfolio does not lead to any changes to this document. Future revisions will occur when appropriate, and any changes will be set out on the document history page.

**Continuity of ordering part numbers**

Infineon continues to support existing part numbers. Please continue to use the ordering part numbers listed in the datasheet for ordering.

## Features

- 25 ns and 45 ns access times
- Internally organized as 32 K × 8 (CY14B256LA)
- Hands off automatic STORE on power-down with only a small capacitor
- STORE to QuantumTrap nonvolatile elements initiated by software, device pin, or AutoStore on power-down
- RECALL to SRAM initiated by software or power-up
- Infinite read, write, and recall cycles
- 1 million STORE cycles to QuantumTrap
- 20-year data retention
- Single 3 V +20% to -10% operation
- Industrial temperature
- 44-pin thin small outline package (TSOP) Type II, 48-pin shrunk small outline package (SSOP), and 32-pin small-outline integrated circuit (SOIC) packages
- Pb-free and restriction of hazardous substances (RoHS) compliance

## Functional Description

The Cypress CY14B256LA is a fast static RAM, with a nonvolatile element in each memory cell. The memory is organized as 32 K bytes of 8 bits each. The embedded nonvolatile elements incorporate QuantumTrap technology, producing the world's most reliable nonvolatile memory. The SRAM provides infinite read and write cycles, while independent nonvolatile data resides in the highly reliable QuantumTrap cell. Data transfers from the SRAM to the nonvolatile elements (the STORE operation) takes place automatically at power-down. On power-up, data is restored to the SRAM (the RECALL operation) from the nonvolatile memory. Both the STORE and RECALL operations are also available under software control.

For a complete list of related documentation, click [here](#).

## Logic Block Diagram

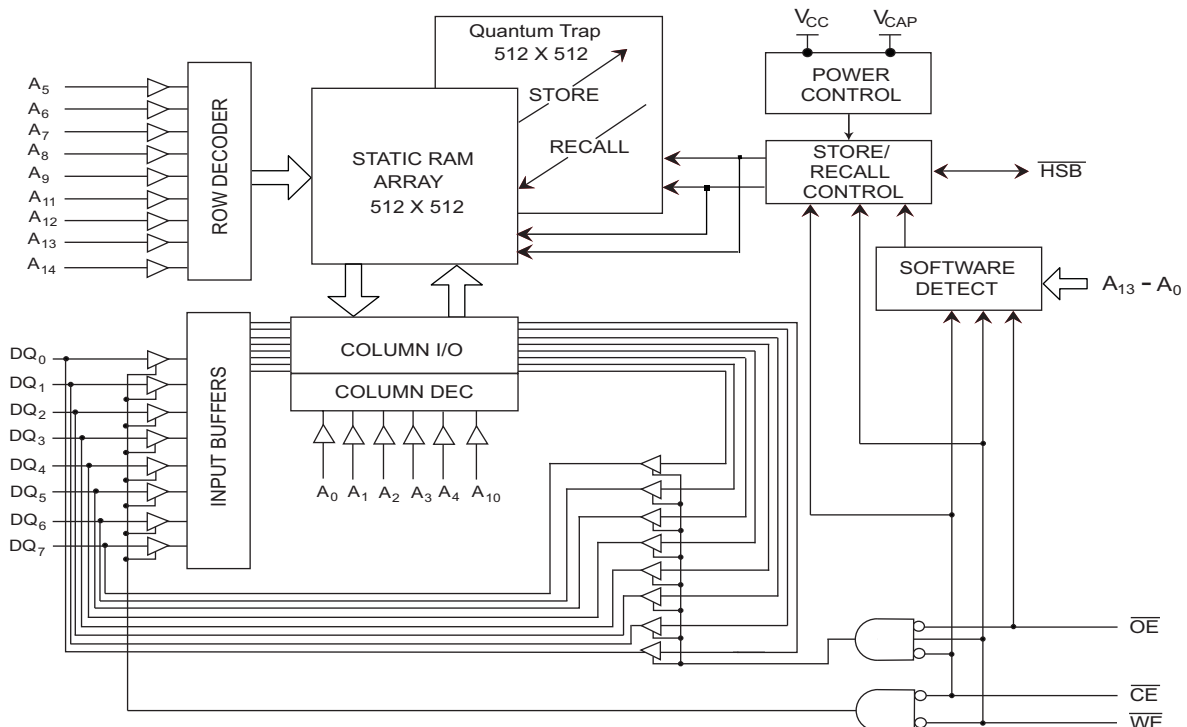

## Contents

<b>Pinouts</b> .....	<b>3</b>	<b>Switching Waveforms</b> .....	<b>11</b>
<b>Pin Definitions</b> .....	<b>4</b>	<b>AutoStore/Power-Up RECALL</b> .....	<b>13</b>
<b>Device Operation</b> .....	<b>5</b>	<b>Switching Waveforms</b> .....	<b>13</b>
SRAM Read .....	5	<b>Software Controlled STORE/RECALL Cycle</b> .....	<b>14</b>
SRAM Write .....	5	<b>Switching Waveforms</b> .....	<b>14</b>
AutoStore Operation .....	5	<b>Hardware STORE Cycle</b> .....	<b>15</b>
Hardware STORE Operation .....	5	<b>Switching Waveforms</b> .....	<b>15</b>
Hardware RECALL (Power-Up) .....	6	<b>Truth Table For SRAM Operations</b> .....	<b>16</b>
Software STORE .....	6	<b>Ordering Information</b> .....	<b>16</b>
Software RECALL .....	6	Ordering Code Definitions .....	16
Preventing AutoStore .....	7	<b>Package Diagrams</b> .....	<b>17</b>
Data Protection .....	7	<b>Acronyms</b> .....	<b>20</b>
<b>Maximum Ratings</b> .....	<b>8</b>	<b>Document Conventions</b> .....	<b>20</b>
<b>Operating Range</b> .....	<b>8</b>	Units of Measure .....	20
<b>DC Electrical Characteristics</b> .....	<b>8</b>	<b>Document History Page</b> .....	<b>21</b>
<b>Data Retention and Endurance</b> .....	<b>9</b>	<b>Sales, Solutions, and Legal Information</b> .....	<b>22</b>
<b>Capacitance</b> .....	<b>9</b>	Worldwide Sales and Design Support .....	22
<b>Thermal Resistance</b> .....	<b>9</b>	Products .....	22
<b>AC Test Loads</b> .....	<b>10</b>	PSoC® Solutions .....	22
<b>AC Test Conditions</b> .....	<b>10</b>	Cypress Developer Community .....	22
<b>AC Switching Characteristics</b> .....	<b>11</b>	Technical Support .....	22

Pinouts

Figure 1. 44-pin TSOP II / 48-pin SSOP pinout

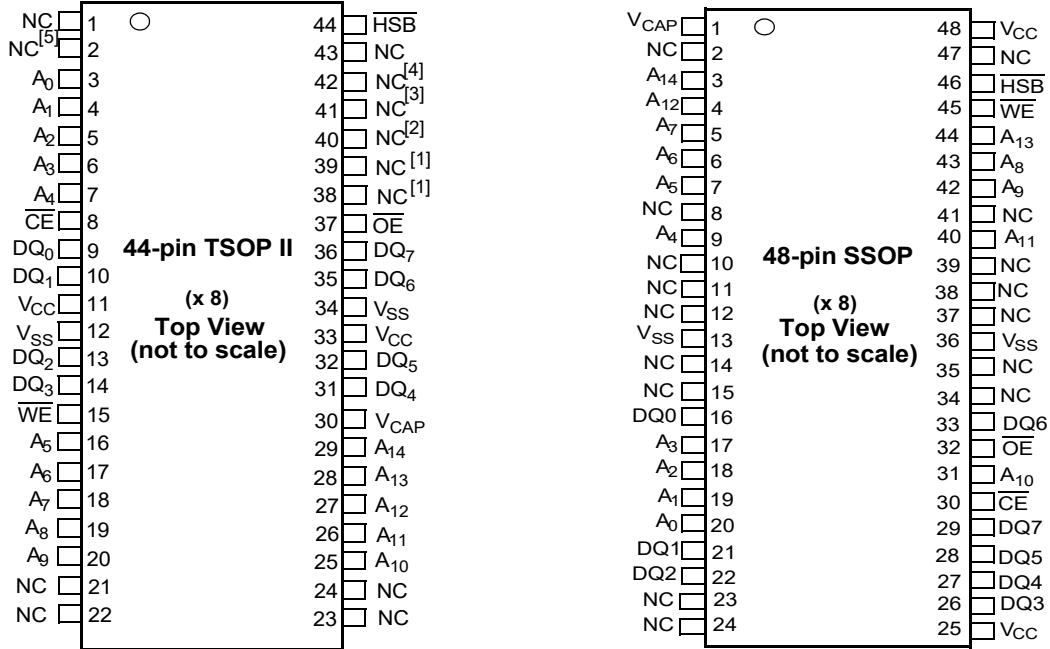
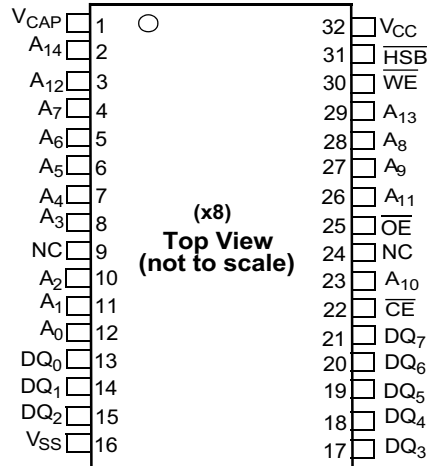

Figure 2. 32-pin SOIC pinout



Notes

1. Address expansion for 1-Mbit. NC pin not connected to die.
2. Address expansion for 2-Mbit. NC pin not connected to die.
3. Address expansion for 4-Mbit. NC pin not connected to die.
4. Address expansion for 8-Mbit. NC pin not connected to die.
5. Address expansion for 16-Mbit. NC pin not connected to die.

## Pin Definitions

Pin Name	I/O Type	Description
A <sub>0</sub> -A <sub>14</sub>	Input	Address inputs. Used to select one of the 32,768 bytes of the nvSRAM.
DQ <sub>0</sub> -DQ <sub>7</sub>	Input/Output	Bidirectional data I/O lines. Used as input or output lines depending on operation.
$\overline{WE}$	Input	Write enable input, active LOW. When the chip is enabled and WE is LOW, data on the I/O pins is written to the specific address location.
$\overline{CE}$	Input	Chip enable input, active LOW. When LOW, selects the chip. When HIGH, deselects the chip.
$\overline{OE}$	Input	Output enable, active LOW. The active LOW $\overline{OE}$ input enables the data output buffers during read cycles. I/O pins are tristated on deasserting $\overline{OE}$ HIGH.
V <sub>SS</sub>	Ground	Ground for the device. Must be connected to the ground of the system.
V <sub>CC</sub>	Power supply	Power supply inputs to the device. 3.0 V +20%, -10%
$\overline{HSB}$	Input/Output	Hardware STORE busy ( $\overline{HSB}$ ). When LOW this output indicates that a Hardware STORE is in progress. When pulled LOW external to the chip it initiates a nonvolatile STORE operation. After each Hardware and Software STORE operation $\overline{HSB}$ is driven HIGH for a short time (t <sub>HHHD</sub> ) with standard output high current and then a weak internal pull-up resistor keeps this pin HIGH (External pull-up resistor connection optional).
V <sub>CAP</sub>	Power supply	AutoStore capacitor. Supplies power to the nvSRAM during power loss to store data from SRAM to nonvolatile elements.
NC	No connect	No connect. This pin is not connected to the die.

## Device Operation

The CY14B256LA nvSRAM is made up of two functional components paired in the same physical cell. They are an SRAM memory cell and a nonvolatile QuantumTrap cell. The SRAM memory cell operates as a standard fast static RAM. Data in the SRAM is transferred to the nonvolatile cell (the STORE operation), or from the nonvolatile cell to the SRAM (the RECALL operation). Using this unique architecture, all cells are stored and recalled in parallel. During the STORE and RECALL operations, SRAM read and write operations are inhibited. The CY14B256LA supports infinite reads and writes similar to a typical SRAM. In addition, it provides infinite RECALL operations from the nonvolatile cells and up to 1 million STORE operations. Refer to the [Truth Table For SRAM Operations on page 16](#) for a complete description of read and write modes.

### SRAM Read

The CY14B256LA performs a read cycle when  $\overline{CE}$  and  $\overline{OE}$  are LOW and  $\overline{WE}$  and HSB are HIGH. The address specified on pins  $A_{0-14}$  determines which of the 32,768 data bytes each are accessed. When the read is initiated by an address transition, the outputs are valid after a delay of  $t_{AA}$  (read cycle 1). If the read is initiated by  $\overline{CE}$  or  $\overline{OE}$ , the outputs are valid at  $t_{ACE}$  or at  $t_{DOE}$ , whichever is later (read cycle 2). The data output repeatedly responds to address changes within the  $t_{AA}$  access time without the need for transitions on any control input pins. This remains valid until another address change or until  $\overline{CE}$  or  $\overline{OE}$  is brought HIGH, or  $\overline{WE}$  or HSB is brought LOW.

### SRAM Write

A write cycle is performed when  $\overline{CE}$  and  $\overline{WE}$  are LOW and HSB is HIGH. The address inputs must be stable before entering the write cycle and must remain stable until  $\overline{CE}$  or  $\overline{WE}$  goes HIGH at the end of the cycle. The data on the common I/O pins  $DQ_{0-7}$  are written into the memory if the data is valid  $t_{SD}$  before the end of a  $\overline{WE}$ -controlled write or before the end of a  $\overline{CE}$ -controlled write. Keep  $\overline{OE}$  HIGH during the entire write cycle to avoid data bus contention on common I/O lines. If  $\overline{OE}$  is left LOW, internal circuitry turns off the output buffers  $t_{HZWE}$  after  $\overline{WE}$  goes LOW.

### AutoStore Operation

The CY14B256LA stores data to the nvSRAM using one of the following three storage operations: Hardware STORE activated by HSB; Software STORE activated by an address sequence; AutoStore on device power-down. The AutoStore operation is a unique feature of QuantumTrap technology and is enabled by default on the CY14B256LA.

During a normal operation, the device draws current from  $V_{CC}$  to charge a capacitor connected to the  $V_{CAP}$  pin. This stored charge is used by the chip to perform a single STORE operation. If the voltage on the  $V_{CC}$  pin drops below  $V_{SWITCH}$ , the part automatically disconnects the  $V_{CAP}$  pin from  $V_{CC}$ . A STORE operation is initiated with power provided by the  $V_{CAP}$  capacitor.

**Note** If the capacitor is not connected to  $V_{CAP}$  pin, AutoStore must be disabled using the soft sequence specified in [Preventing AutoStore on page 7](#). In case AutoStore is enabled without a capacitor on  $V_{CAP}$  pin, the device attempts an AutoStore operation without sufficient charge to complete the Store. This will corrupt the data stored in nvSRAM.

Figure 3 shows the proper connection of the storage capacitor ( $V_{CAP}$ ) for automatic STORE operation. Refer to [DC Electrical Characteristics on page 8](#) for the size of  $V_{CAP}$ . The voltage on the  $V_{CAP}$  pin is driven to  $V_{CC}$  by a regulator on the chip. Place a pull-up on  $\overline{WE}$  to hold it inactive during power-up. This pull-up is only effective if the  $\overline{WE}$  signal is tristate during power-up. Many MPUs tristate their controls on power-up. This must be verified when using the pull-up. When the nvSRAM comes out of power-on-recall, the MPU must be active or the  $\overline{WE}$  held inactive until the MPU comes out of reset.

To reduce unnecessary nonvolatile stores, AutoStore and Hardware STORE operations are ignored unless at least one write operation has taken place since the most recent STORE or RECALL cycle. Software-initiated STORE cycles are performed regardless of whether a write operation has taken place. The HSB signal is monitored by the system to detect if an AutoStore cycle is in progress.

Figure 3. AutoStore Mode

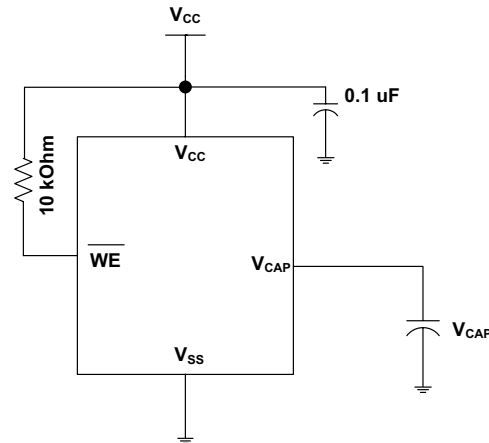

### Hardware STORE Operation

The CY14B256LA provides the HSB pin to control and acknowledge the STORE operations. Use the HSB pin to request a Hardware STORE cycle. When the HSB pin is driven LOW, the CY14B256LA conditionally initiates a STORE operation after  $t_{DELAY}$ . An actual STORE cycle only begins if a write to the SRAM has taken place since the last STORE or RECALL cycle. The HSB pin also acts as an open drain driver (internal 100 kΩ weak pull-up resistor) that is internally driven LOW to indicate a busy condition when the STORE (initiated by any means) is in progress.

**Note** After each Hardware and Software STORE operation HSB is driven HIGH for a short time ( $t_{HHHD}$ ) with standard output high current and then remains HIGH by internal 100 kΩ pull-up resistor.

SRAM write operations that are in progress when HSB is driven LOW by any means are given time ( $t_{DELAY}$ ) to complete before the STORE operation is initiated. However, any SRAM write cycles requested after HSB goes LOW are inhibited until HSB returns HIGH. In case the write latch is not set, HSB is not driven LOW by the CY14B256LA. But any SRAM read and write cycles are inhibited until HSB is returned HIGH by MPU or other external source.

During any STORE operation, regardless of how it is initiated, the CY14B256LA continues to drive the HSB pin LOW, releasing it only when the STORE is complete. Upon completion of the STORE operation, the nvSRAM memory access is inhibited for  $t_{LZHSB}$  time after HSB pin returns HIGH. Leave the HSB unconnected if it is not used.

### Hardware RECALL (Power-Up)

During power-up or after any low-power condition ( $V_{CC} < V_{SWITCH}$ ), an internal RECALL request is latched. When  $V_{CC}$  again exceeds the sense voltage of  $V_{SWITCH}$ , a RECALL cycle is automatically initiated and takes  $t_{HRECALL}$  to complete. During this time, HSB is driven low by the HSB driver.

### Software STORE

Data is transferred from SRAM to the nonvolatile memory by a software address sequence. The CY14B256LA Software STORE cycle is initiated by executing sequential  $\overline{CE}$  or  $\overline{OE}$  controlled read cycles from six specific address locations in exact order. During the STORE cycle an erase of the previous nonvolatile data is first performed, followed by a program of the nonvolatile elements. After a STORE cycle is initiated, further input and output are disabled until the cycle is completed.

Because a sequence of READs from specific addresses is used for STORE initiation, it is important that no other read or write accesses intervene in the sequence, or the sequence is aborted and no STORE or RECALL takes place.

To initiate the Software STORE cycle, the following read sequence must be performed:

1. Read address 0x0E38 valid READ
2. Read address 0x31C7 valid READ
3. Read address 0x03E0 valid READ
4. Read address 0x3C1F valid READ
5. Read address 0x303F valid READ
6. Read address 0x0FC0 initiate STORE cycle

The software sequence may be clocked with  $\overline{CE}$  controlled reads or  $\overline{OE}$  controlled reads, with  $\overline{WE}$  kept HIGH for all the six READ sequences. After the sixth address in the sequence is entered, the STORE cycle commences and the chip is disabled. HSB is driven LOW. After the  $t_{STORE}$  cycle time is fulfilled, the SRAM is activated again for the read and write operation.

### Software RECALL

Data is transferred from nonvolatile memory to the SRAM by a software address sequence. A Software RECALL cycle is initiated with a sequence of read operations in a manner similar to the Software STORE initiation. To initiate the RECALL cycle, the following sequence of  $\overline{CE}$  or  $\overline{OE}$  controlled read operations must be performed:

1. Read address 0x0E38 valid READ
2. Read address 0x31C7 valid READ
3. Read address 0x03E0 valid READ
4. Read address 0x3C1F valid READ
5. Read address 0x303F valid READ
6. Read address 0x0C63 initiate RECALL cycle

Internally, RECALL is a two step procedure. First, the SRAM data is cleared. Next, the nonvolatile information is transferred into the SRAM cells. After the  $t_{RECALL}$  cycle time, the SRAM is again ready for read and write operations. The RECALL operation does not alter the data in the nonvolatile elements.

**Table 1. Mode Selection**

$\overline{CE}$	$\overline{WE}$	$\overline{OE}$	$A_{14}-A_0$ <sup>[6]</sup>	Mode	I/O	Power
H	X	X	X	Not selected	Output high Z	Standby
L	H	L	X	Read SRAM	Output data	Active
L	L	X	X	Write SRAM	Input data	Active
L	H	L	0x0E38 0x31C7 0x03E0 0x3C1F 0x303F 0x0B45	Read SRAM Read SRAM Read SRAM Read SRAM Read SRAM AutoStore Disable	Output data Output data Output data Output data Output data Output data	Active <sup>[7]</sup>

**Notes**

6. While there are 15 address lines on the CY14B256LA, only the lower 14 are used to control software modes.
7. The six consecutive address locations must be in the order listed.  $\overline{WE}$  must be HIGH during all six cycles to enable a nonvolatile cycle.

**Table 1. Mode Selection** (continued)

$\overline{CE}$	$\overline{WE}$	$\overline{OE}$	$A_{14}-A_0$ <sup>[6]</sup>	Mode	I/O	Power
L	H	L	0x0E38 0x31C7 0x03E0 0x3C1F 0x303F 0x0B46	Read SRAM Read SRAM Read SRAM Read SRAM Read SRAM AutoStore Enable	Output data Output data Output data Output data Output data Output data	Active <sup>[8]</sup>
L	H	L	0x0E38 0x31C7 0x03E0 0x3C1F 0x303F 0x0FC0	Read SRAM Read SRAM Read SRAM Read SRAM Read SRAM Nonvolatile STORE	Output data Output data Output data Output data Output data Output high Z	Active I <sub>CC2</sub> <sup>[8]</sup>
L	H	L	0x0E38 0x31C7 0x03E0 0x3C1F 0x303F 0x0C63	Read SRAM Read SRAM Read SRAM Read SRAM Read SRAM Nonvolatile Recall	Output data Output data Output data Output data Output data Output high Z	Active <sup>[8]</sup>

### Preventing AutoStore

The AutoStore function is disabled by initiating an AutoStore disable sequence. A sequence of read operations is performed in a manner similar to the Software STORE initiation. To initiate the AutoStore disable sequence, the following sequence of  $\overline{CE}$  or  $\overline{OE}$  controlled read operations must be performed:

1. Read address 0x0E38 valid READ
2. Read address 0x31C7 valid READ
3. Read address 0x03E0 valid READ
4. Read address 0x3C1F valid READ
5. Read address 0x303F valid READ
6. Read address 0x0B45 AutoStore disable

The AutoStore is reenabled by initiating an AutoStore enable sequence. A sequence of read operations is performed in a manner similar to the Software RECALL initiation. To initiate the

AutoStore enable sequence, the following sequence of  $\overline{CE}$  or  $\overline{OE}$  controlled read operations must be performed:

1. Read address 0x0E38 valid READ
2. Read address 0x31C7 valid READ
3. Read address 0x03E0 valid READ
4. Read address 0x3C1F valid READ
5. Read address 0x303F valid READ
6. Read address 0x0B46 AutoStore enable

If the AutoStore function is disabled or reenabled, a manual STORE operation (Hardware or Software) must be issued to save the AutoStore state through subsequent power-down cycles. The part comes from the factory with AutoStore enabled and 0x00 written in all cells.

### Data Protection

The CY14B256LA protects data from corruption during low voltage conditions by inhibiting all externally initiated STORE and write operations. The low voltage condition is detected when  $V_{CC}$  is less than  $V_{SWITCH}$ . If the CY14B256LA is in a write mode (both  $\overline{CE}$  and  $\overline{WE}$  are LOW) at power-up, after a RECALL or STORE, the write is inhibited until the SRAM is enabled after  $t_{LZHSB}$  (HSB to output active). This protects against inadvertent writes during power-up or brown out conditions.

#### Note

8. The six consecutive address locations must be in the order listed.  $\overline{WE}$  must be HIGH during all six cycles to enable a nonvolatile cycle.

## Maximum Ratings

Exceeding maximum ratings may impair the useful life of the device. These user guidelines are not tested.

Storage temperature ..... -65 °C to +150 °C

Maximum accumulated storage time:

At 150 °C ambient temperature ..... 1000 h

At 85 °C ambient temperature ..... 20 years

Maximum junction temperature ..... 150 °C

Supply voltage on  $V_{CC}$  relative to  $V_{SS}$  ..... -0.5 V to 4.1 V

Voltage applied to outputs

in high Z state ..... -0.5 V to  $V_{CC} + 0.5$  V

Input voltage ..... -0.5 V to  $V_{CC} + 0.5$  V

Transient voltage (< 20 ns) on

any pin to ground potential ..... -2.0 V to  $V_{CC} + 2.0$  V

Package power dissipation

capability ( $T_A = 25$  °C) ..... 1.0 W

Surface mount Pb soldering

temperature (3 seconds) ..... +260 °C

DC output current (1 output at a time, 1s duration) .... 15 mA

Static discharge voltage

(per MIL-STD-883, Method 3015) ..... > 2001 V

Latch-up current ..... > 200 mA

## Operating Range

Range	Ambient Temperature	$V_{CC}$
Industrial	-40 °C to +85 °C	2.7 V to 3.6 V

## DC Electrical Characteristics

Over the [Operating Range](#)

Parameter	Description	Test Conditions	Min	Typ <sup>[9]</sup>	Max	Unit
$V_{CC}$	Power supply		2.7	3.0	3.6	V
$I_{CC1}$	Average $V_{CC}$ current	$t_{RC} = 25$ ns $t_{RC} = 45$ ns Values obtained without output loads ( $I_{OUT} = 0$ mA)	-	-	70 52	mA mA
$I_{CC2}$	Average $V_{CC}$ current during STORE	All inputs don't care, $V_{CC} = \text{Max}$ Average current for duration $t_{STORE}$	-	-	10	mA
$I_{CC3}$	Average $V_{CC}$ current at $t_{RC} = 200$ ns, $V_{CC(Typ)}$ , 25 °C	All inputs cycling at CMOS levels. Values obtained without output loads ( $I_{OUT} = 0$ mA).	-	35	-	mA
$I_{CC4}$	Average $V_{CAP}$ current during AutoStore cycle	All inputs don't Care. Average current for duration $t_{STORE}$	-	-	5	mA
$I_{SB}$	$V_{CC}$ standby current	$\overline{CE} \geq (V_{CC} - 0.2$ V). $V_{IN} \leq 0.2$ V or $\geq (V_{CC} - 0.2$ V). Standby current level after nonvolatile cycle is complete. Inputs are static. $f = 0$ MHz.	-	-	5	mA
$I_{IX}^{[10]}$	Input leakage current (except $\overline{HSB}$ )	$V_{CC} = \text{Max}$ , $V_{SS} \leq V_{IN} \leq V_{CC}$	-1	-	+1	$\mu$ A
	Input leakage current (for $\overline{HSB}$ )	$V_{CC} = \text{Max}$ , $V_{SS} \leq V_{IN} \leq V_{CC}$	-100	-	+1	$\mu$ A
$I_{OZ}$	Off-state output leakage current	$V_{CC} = \text{Max}$ , $V_{SS} \leq V_{OUT} \leq V_{CC}$ , $\overline{CE}$ or $\overline{OE} \geq V_{IH}$ or $\overline{WE} \leq V_{IL}$	-1	-	+1	$\mu$ A
$V_{IH}$	Input HIGH voltage		2.0	-	$V_{CC} + 0.5$	V
$V_{IL}$	Input LOW voltage		$V_{SS} - 0.5$	-	0.8	V
$V_{OH}$	Output HIGH voltage	$I_{OUT} = -2$ mA	2.4	-		V
$V_{OL}$	Output LOW voltage	$I_{OUT} = 4$ mA	-	-	0.4	V

### Notes

9. Typical values are at 25 °C,  $V_{CC} = V_{CC(Typ)}$ . Not 100% tested.

10. The  $\overline{HSB}$  pin has  $I_{OUT} = -2$   $\mu$ A for  $V_{OH}$  of 2.4 V when both active high and low drivers are disabled. When they are enabled standard  $V_{OH}$  and  $V_{OL}$  are valid. This parameter is characterized but not tested.

## DC Electrical Characteristics (continued)

Over the [Operating Range](#)

Parameter	Description	Test Conditions	Min	Typ <sup>[9]</sup>	Max	Unit
V <sub>CAP</sub> <sup>[11]</sup>	Storage capacitor	Between V <sub>CAP</sub> pin and V <sub>SS</sub>	61	68	180	μF
V <sub>VCAP</sub> <sup>[12, 13]</sup>	Maximum voltage driven on V <sub>CAP</sub> pin by the device	V <sub>CC</sub> = Max	–	–	V <sub>CC</sub>	V

## Data Retention and Endurance

Over the [Operating Range](#)

Parameter	Description	Min	Unit
DATA <sub>R</sub>	Data retention	20	Years
NV <sub>C</sub>	Nonvolatile STORE operations	1,000	K

## Capacitance

Parameter <sup>[13]</sup>	Description	Test Conditions	Max	Unit
C <sub>IN</sub>	Input capacitance (except HSB)	T <sub>A</sub> = 25 °C, f = 1 MHz, V <sub>CC</sub> = V <sub>CC(Typ)</sub>	7	pF
	Input capacitance (for HSB)		8	pF
C <sub>OUT</sub>	Output capacitance (except HSB)		7	pF
	Output capacitance (for HSB)		8	pF

## Thermal Resistance

Parameter <sup>[13]</sup>	Description	Test Conditions	48-pin SSOP	44-pin TSOP II	32-pin SOIC	Unit
Θ <sub>JA</sub>	Thermal resistance (Junction to ambient)	Test conditions follow standard test methods and procedures for measuring thermal impedance, in accordance with EIA/JESD51.	37.47	41.74	41.55	°C/W
Θ <sub>JC</sub>	Thermal resistance (Junction to case)		24.71	11.9	24.43	°C/W

### Notes

- Min V<sub>CAP</sub> value guarantees that there is a sufficient charge available to complete a successful AutoStore operation. Max V<sub>CAP</sub> value guarantees that the capacitor on V<sub>CAP</sub> is charged to a minimum voltage during a Power-Up RECALL cycle so that an immediate power-down cycle can complete a successful AutoStore. Therefore it is always recommended to use a capacitor within the specified min and max limits. Refer application note [AN43593](#) for more details on V<sub>CAP</sub> options.
- Maximum voltage on V<sub>CAP</sub> pin (V<sub>VCAP</sub>) is provided for guidance when choosing the V<sub>CAP</sub> capacitor. The voltage rating of the V<sub>CAP</sub> capacitor across the operating temperature range should be higher than the V<sub>VCAP</sub> voltage.
- These parameters are guaranteed by design and are not tested.

**AC Test Loads**

Figure 4. AC Test Loads

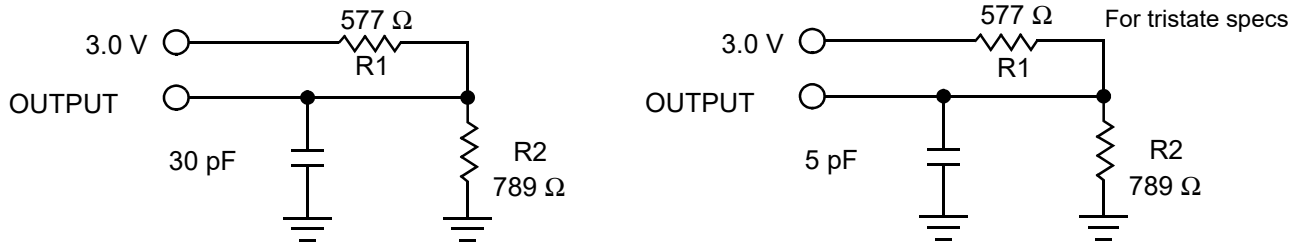

**AC Test Conditions**

Input Pulse Levels ..... 0 V to 3 V  
 Input Rise and Fall Times (10%–90%) ..... ≤ 3 ns  
 Input and Output Timing Reference Levels ..... 1.5 V

## AC Switching Characteristics

Over the [Operating Range](#)

Parameters <sup>[14]</sup>		Description	25 ns		45 ns		Unit
Cypress Parameters	Alt Parameters		Min	Max	Min	Max	
<b>SRAM Read Cycle</b>							
t <sub>ACE</sub>	t <sub>ACS</sub>	Chip enable access time	–	25	–	45	ns
t <sub>RC</sub> <sup>[15]</sup>	t <sub>RC</sub>	Read cycle time	25	–	45	–	ns
t <sub>AA</sub> <sup>[16]</sup>	t <sub>AA</sub>	Address access time	–	25	–	45	ns
t <sub>DOE</sub>	t <sub>OE</sub>	Output enable to data valid	–	12	–	20	ns
t <sub>OHA</sub> <sup>[16]</sup>	t <sub>OH</sub>	Output hold after address change	3	–	3	–	ns
t <sub>LZCE</sub> <sup>[17, 18]</sup>	t <sub>LZ</sub>	Chip enable to output active	3	–	3	–	ns
t <sub>HZCE</sub> <sup>[17, 18]</sup>	t <sub>HZ</sub>	Chip disable to output inactive	–	10	–	15	ns
t <sub>LZOE</sub> <sup>[17, 18]</sup>	t <sub>OLZ</sub>	Output enable to output active	0	–	0	–	ns
t <sub>HZOE</sub> <sup>[17, 18]</sup>	t <sub>OHZ</sub>	Output disable to output inactive	–	10	–	15	ns
t <sub>PU</sub> <sup>[17]</sup>	t <sub>PA</sub>	Chip enable to power active	0	–	0	–	ns
t <sub>PD</sub> <sup>[17]</sup>	t <sub>PS</sub>	Chip disable to power standby	–	25	–	45	ns
<b>SRAM Write Cycle</b>							
t <sub>WC</sub>	t <sub>WC</sub>	Write cycle time	25	–	45	–	ns
t <sub>PWE</sub>	t <sub>WP</sub>	Write pulse width	20	–	30	–	ns
t <sub>SCE</sub>	t <sub>CW</sub>	Chip enable to end of write	20	–	30	–	ns
t <sub>SD</sub>	t <sub>DW</sub>	Data setup to end of write	10	–	15	–	ns
t <sub>HD</sub>	t <sub>DH</sub>	Data hold after end of write	0	–	0	–	ns
t <sub>AW</sub>	t <sub>AW</sub>	Address setup to end of write	20	–	30	–	ns
t <sub>SA</sub>	t <sub>AS</sub>	Address setup to start of write	0	–	0	–	ns
t <sub>HA</sub>	t <sub>WR</sub>	Address hold after end of write	0	–	0	–	ns
t <sub>HZWE</sub> <sup>[17, 18, 19]</sup>	t <sub>WZ</sub>	Write enable to output disable	–	10	–	15	ns
t <sub>LZWE</sub> <sup>[17, 18]</sup>	t <sub>OW</sub>	Output active after end of write	3	–	3	–	ns

## Switching Waveforms

Figure 5. SRAM Read Cycle #1 (Address Controlled) <sup>[15, 16, 20]</sup>

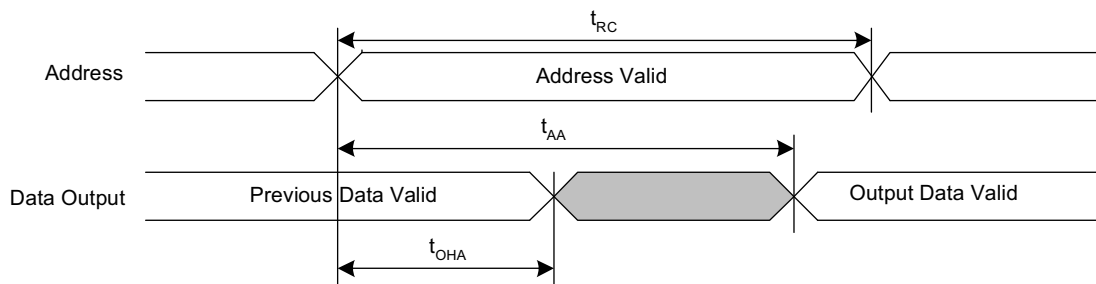

### Notes

14. Test conditions assume signal transition time of 3 ns or less, timing reference levels of V<sub>CC</sub>/2, input pulse levels of 0 to V<sub>CC(typ)</sub>, and output loading of the specified I<sub>OL</sub>/I<sub>OH</sub> and load capacitance shown in [Figure 4](#).
15. WE must be HIGH during SRAM read cycles.
16. Device is continuously selected with CE and OE LOW.
17. These parameters are guaranteed by design and are not tested.
18. Measured ±200 mV from steady state output voltage.
19. If WE is low when CE goes low, the outputs remain in the high impedance state.
20. HSB must remain HIGH during READ and WRITE cycles.

Switching Waveforms (continued)

Figure 6. SRAM Read Cycle #2 ( $\overline{CE}$  and  $\overline{OE}$  Controlled) [21, 22]

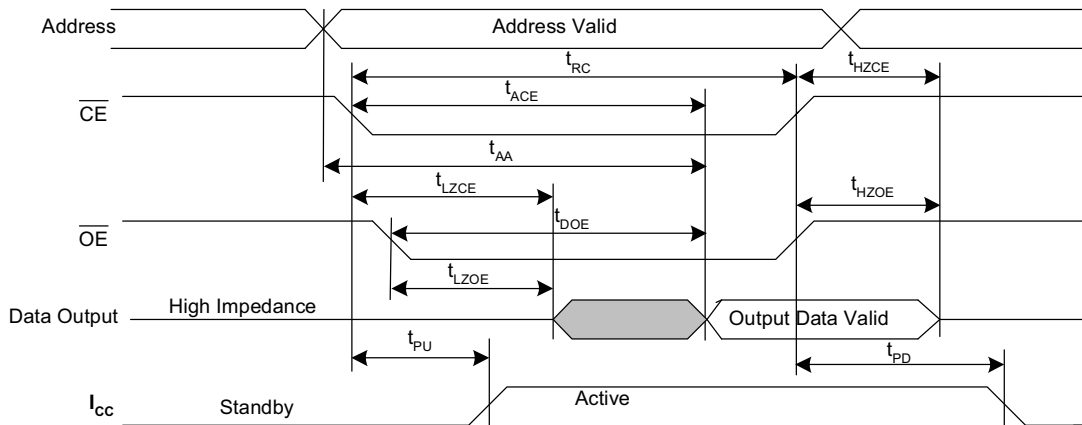

Figure 7. SRAM Write Cycle #1 ( $\overline{WE}$  Controlled) [22, 23, 24]

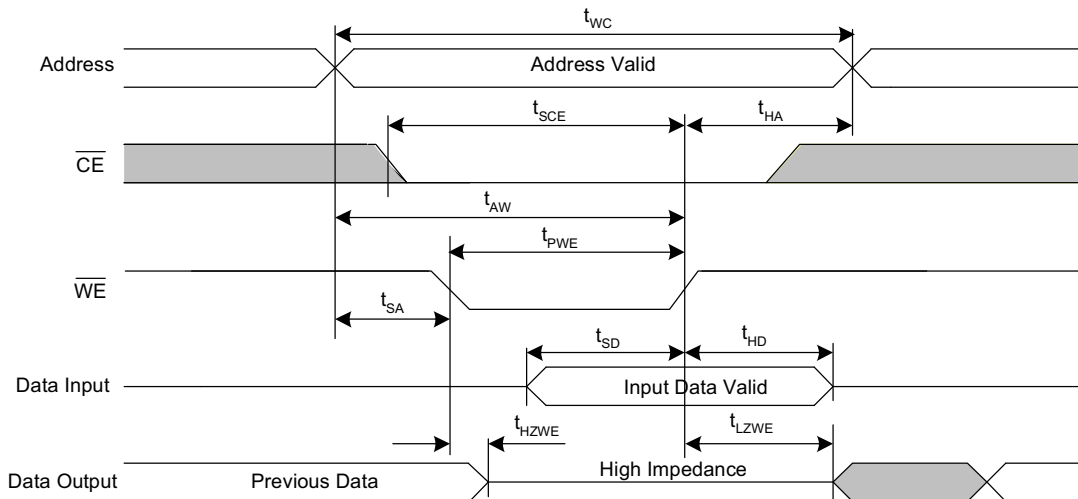
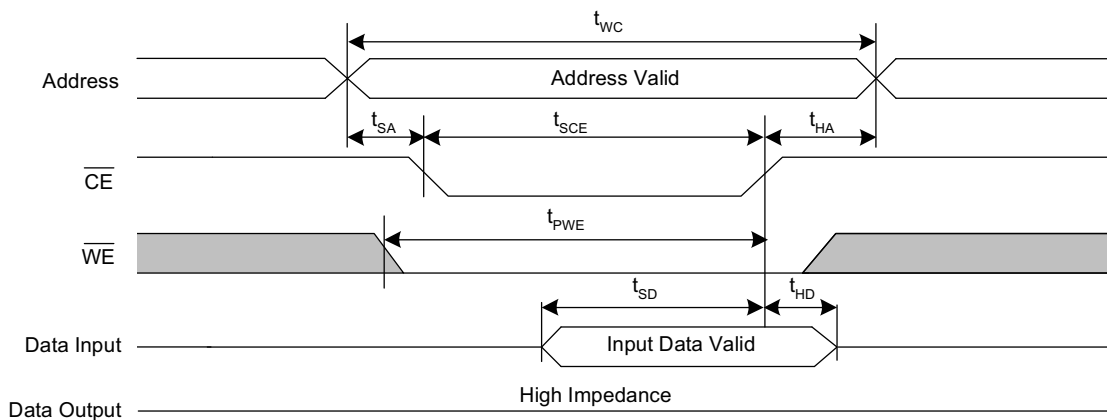

Figure 8. SRAM Write Cycle #2 ( $\overline{CE}$  Controlled) [22, 23, 24]



Notes

- 21.  $\overline{WE}$  must be HIGH during SRAM read cycles.
- 22.  $\overline{HSB}$  must remain HIGH during READ and WRITE cycles.
- 23. If  $\overline{WE}$  is low when  $\overline{CE}$  goes low, the outputs remain in the high impedance state.
- 24.  $\overline{CE}$  or  $\overline{WE}$  must be  $\geq V_{IH}$  during address transitions.

## AutoStore/Power-Up RECALL

Over the Operating Range

Parameters	Description	CY14B256LA		Unit
		Min	Max	
$t_{HRECALL}^{[25]}$	Power-up RECALL duration	–	20	ms
$t_{STORE}^{[26]}$	STORE cycle duration	–	8	ms
$t_{DELAY}^{[27]}$	Time allowed to complete SRAM write cycle	–	25	ns
$V_{SWITCH}$	Low voltage trigger level	–	2.65	V
$t_{VCCRRISE}^{[28]}$	$V_{CC}$ rise time	150	–	$\mu$ s
$V_{HDIS}^{[28]}$	HSB output disable voltage	–	1.9	V
$t_{LZHSB}^{[28]}$	HSB to output active time	–	5	$\mu$ s
$t_{HHHD}^{[28]}$	HSB high active time	–	500	ns

## Switching Waveforms

Figure 9. AutoStore or Power-Up RECALL [29]

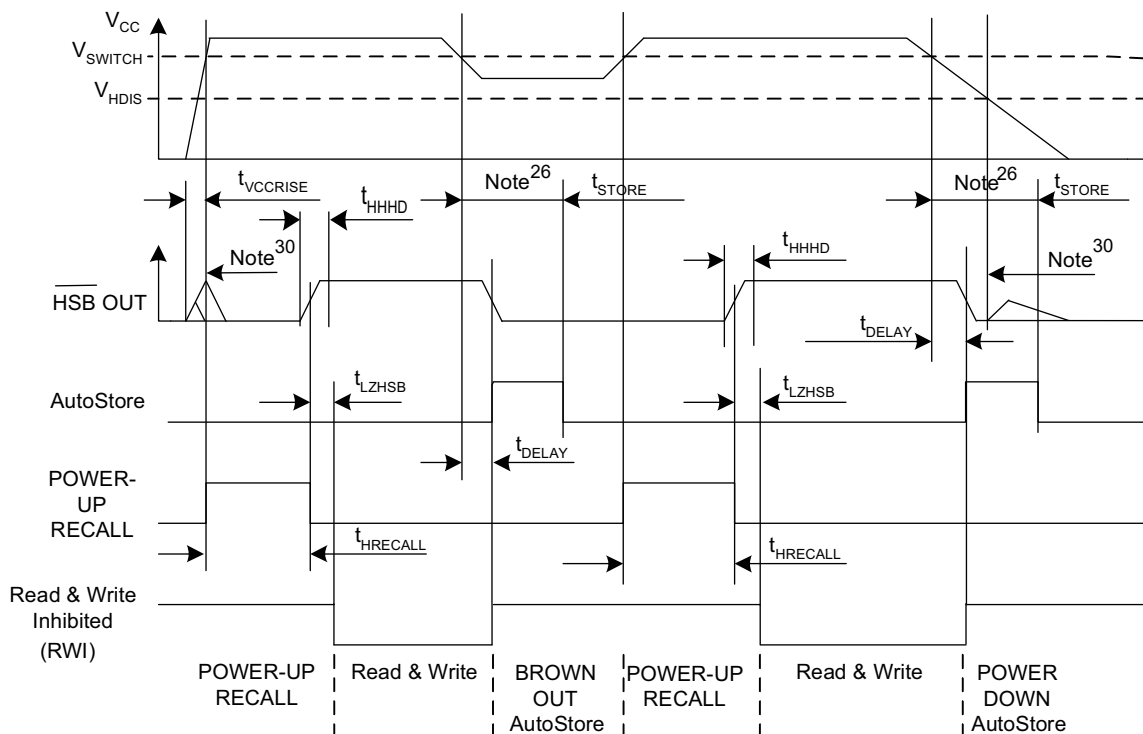

### Notes

- 25.  $t_{HRECALL}$  starts from the time  $V_{CC}$  rises above  $V_{SWITCH}$ .
- 26. If an SRAM write has not taken place since the last nonvolatile cycle, no AutoStore or Hardware STORE takes place.
- 27. On a Hardware Store and AutoStore initiation, SRAM write operation continues to be enabled for time  $t_{DELAY}$ .
- 28. These parameters are guaranteed by design and are not tested.
- 29. Read and Write cycles are ignored during STORE, RECALL, and while  $V_{CC}$  is below  $V_{SWITCH}$ .
- 30. During power-up and power-down, HSB glitches when HSB pin is pulled up through an external resistor.

## Software Controlled STORE/RECALL Cycle

Over the Operating Range

Parameters [31, 32]	Description	25 ns		45 ns		Unit
		Min	Max	Min	Max	
$t_{RC}$	STORE/RECALL initiation cycle time	25	–	45	–	ns
$t_{SA}$	Address setup time	0	–	0	–	ns
$t_{CW}$	Clock pulse width	20	–	30	–	ns
$t_{HA}$	Address hold time	0	–	0	–	ns
$t_{RECALL}$	RECALL duration	–	200	–	200	$\mu$ s

## Switching Waveforms

Figure 10.  $\overline{CE}$  and  $\overline{OE}$  Controlled Software STORE/RECALL Cycle [32]

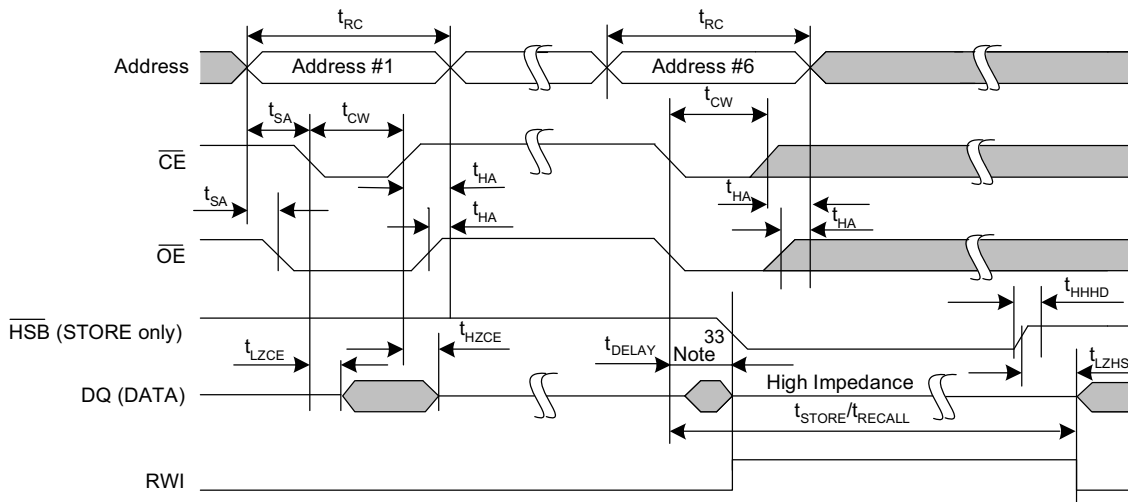
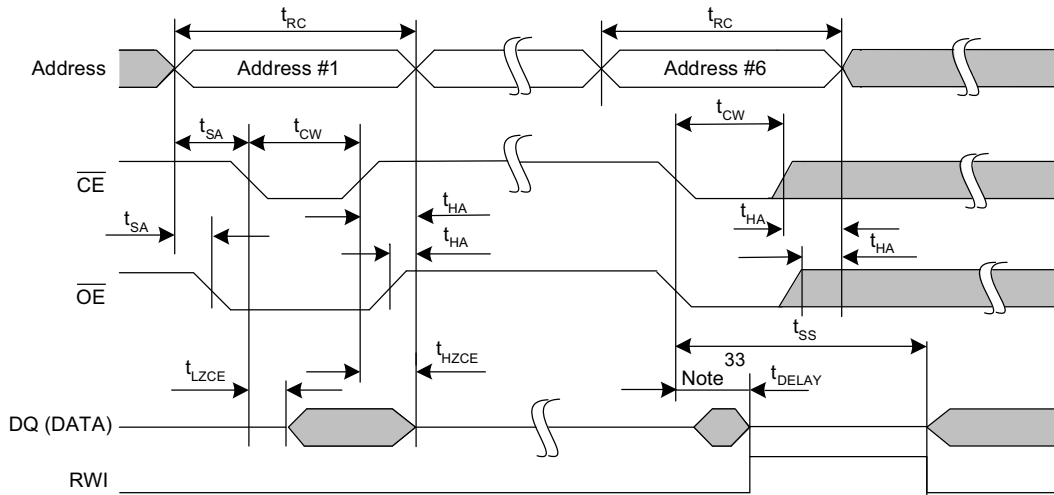

Figure 11. Autostore Enable / Disable Cycle [32]



### Notes

31. The software sequence is clocked with  $\overline{CE}$  controlled or  $\overline{OE}$  controlled reads.

32. The six consecutive addresses must be read in the order listed in Table 1 on page 6.  $\overline{WE}$  must be HIGH during all six consecutive cycles.

33. DQ output data at the sixth read may be invalid since the output is disabled at  $t_{DELAY}$  time.

## Hardware STORE Cycle

Over the [Operating Range](#)

Parameters	Description	CY14B256LA		Unit
		Min	Max	
$t_{DHSB}$	HSB to output active time when write latch is not set	–	25	ns
$t_{PHSB}$	Hardware STORE pulse width	15	–	ns
$t_{SS}$ [34, 35]	Soft sequence processing time	–	100	$\mu$ s

## Switching Waveforms

Figure 12. Hardware STORE Cycle [36]

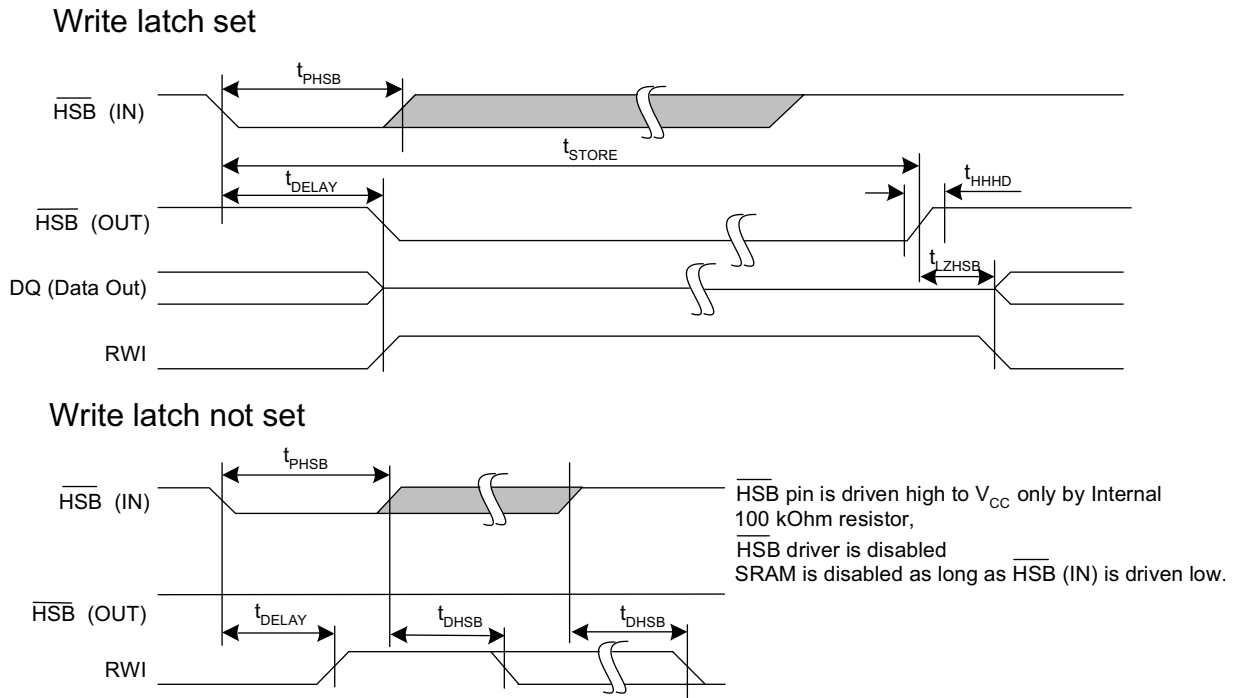
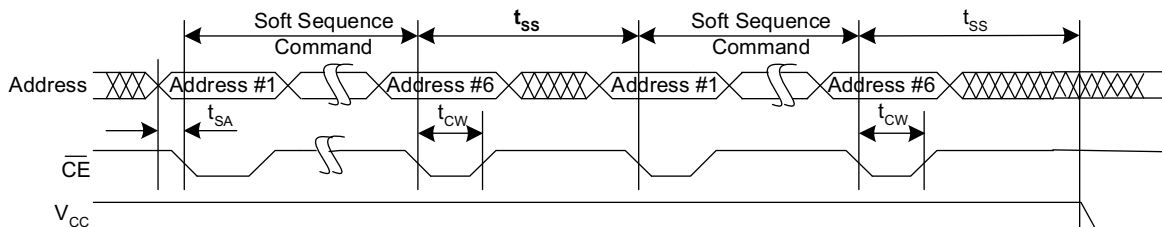

Figure 13. Soft Sequence Processing [34, 35]



**Notes**

- 34. This is the amount of time it takes to take action on a soft sequence command. Vcc power must remain HIGH to effectively register command.
- 35. Commands such as STORE and RECALL lock out I/O until operation is complete which further increases this time. See the specific command.
- 36. If an SRAM write has not taken place since the last nonvolatile cycle, no AutoStore or Hardware STORE takes place.

### Truth Table For SRAM Operations

HSB must remain HIGH for SRAM operations.

Table 2. Truth Table

CE	WE	OE	Inputs/Outputs	Mode	Power
H	X	X	High Z	Deselect/power-down	Standby
L	H	L	Data out (DQ <sub>0</sub> –DQ <sub>7</sub> );	Read	Active
L	H	H	High Z	Output disabled	Active
L	L	X	Data in (DQ <sub>0</sub> –DQ <sub>7</sub> );	Write	Active

### Ordering Information

Speed (ns)	Ordering Code	Package Diagram	Package Type	Operating Range
25	CY14B256LA-ZS25XIT	51-85087	44-pin TSOP II	Industrial
	CY14B256LA-ZS25XI	51-85087	44-pin TSOP II	
	CY14B256LA-SP25XIT	51-85061	48-pin SSOP	
	CY14B256LA-SP25XI	51-85061	48-pin SSOP	
	CY14B256LA-SZ25XIT	51-85127	32-pin SOIC	
	CY14B256LA-SZ25XI	51-85127	32-pin SOIC	
45	CY14B256LA-SP45XIT	51-85061	48-pin SSOP	Industrial
	CY14B256LA-SP45XI	51-85061	48-pin SSOP	
	CY14B256LA-SZ45XIT	51-85127	32-pin SOIC	
	CY14B256LA-SZ45XI	51-85127	32-pin SOIC	

All the above parts are Pb-free.

### Ordering Code Definitions

CY 14 B 256 L A - ZS 25 X I T

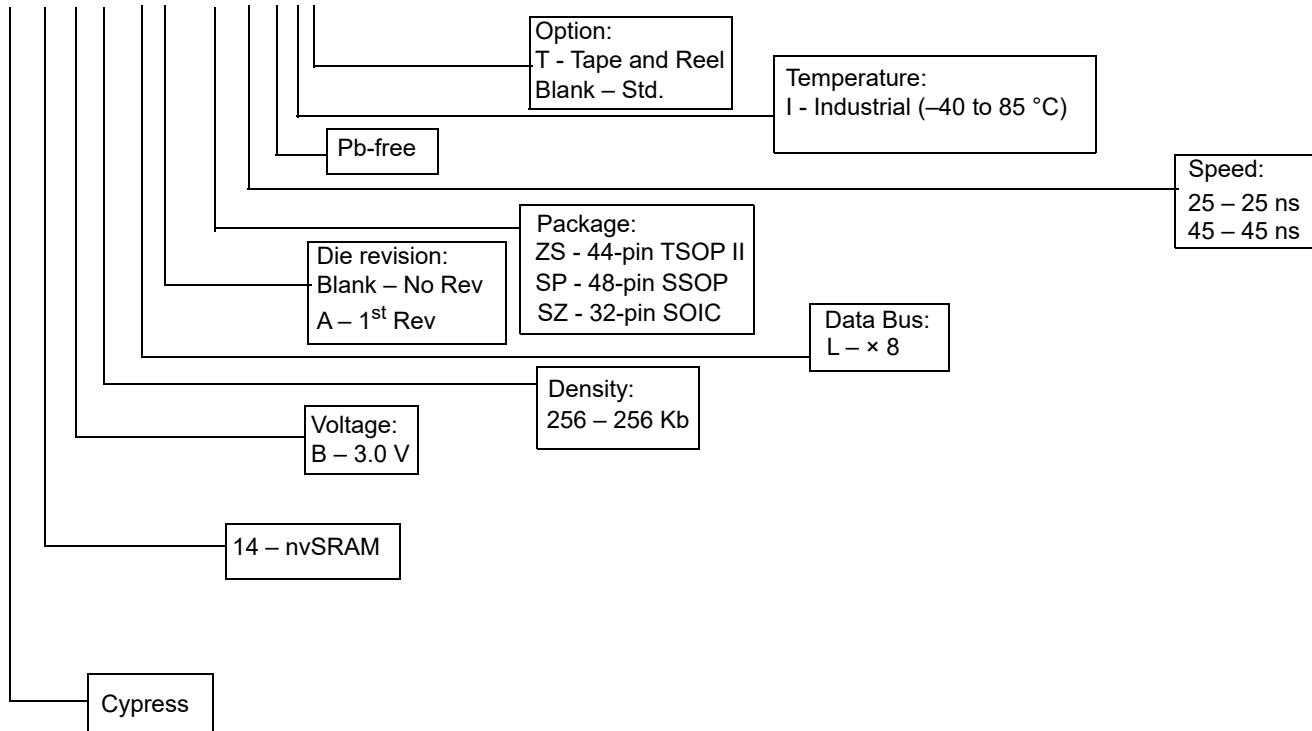

Package Diagrams

Figure 14. 44-pin TSOP II Package Outline, 51-85087

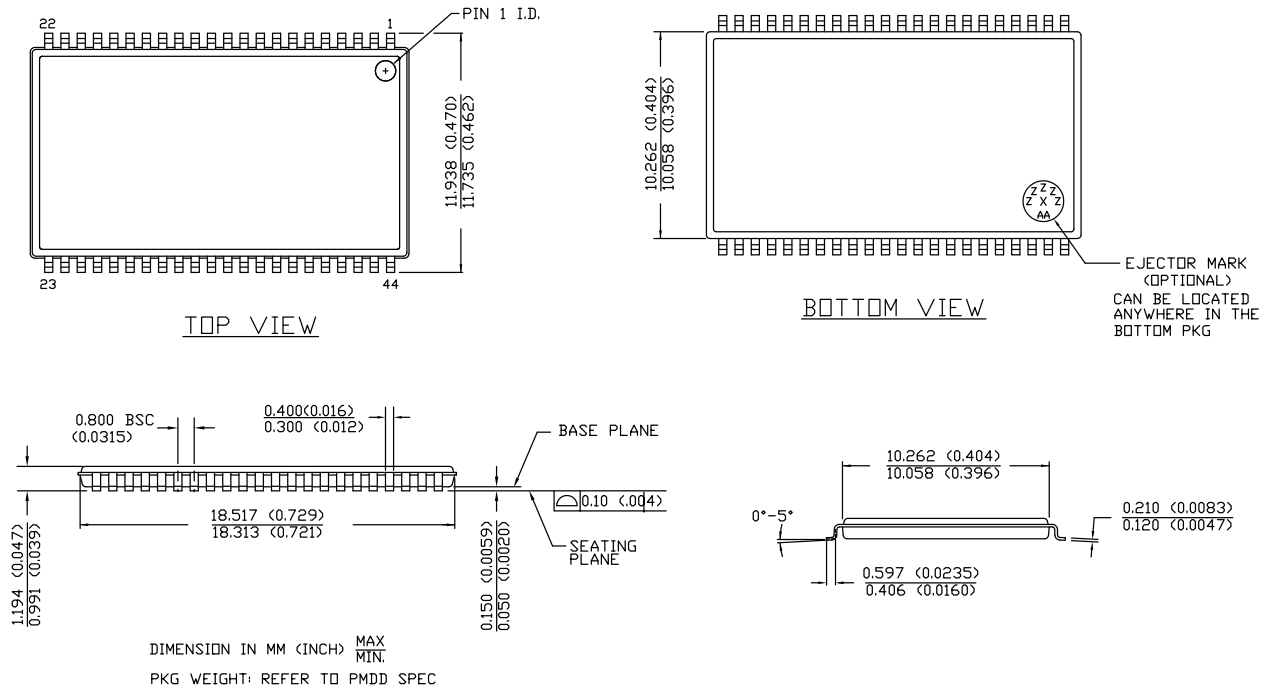

51-85087 \*E

Package Diagrams (continued)

Figure 15. 48-pin SSOP (300 Mils) Package Outline, 51-85061

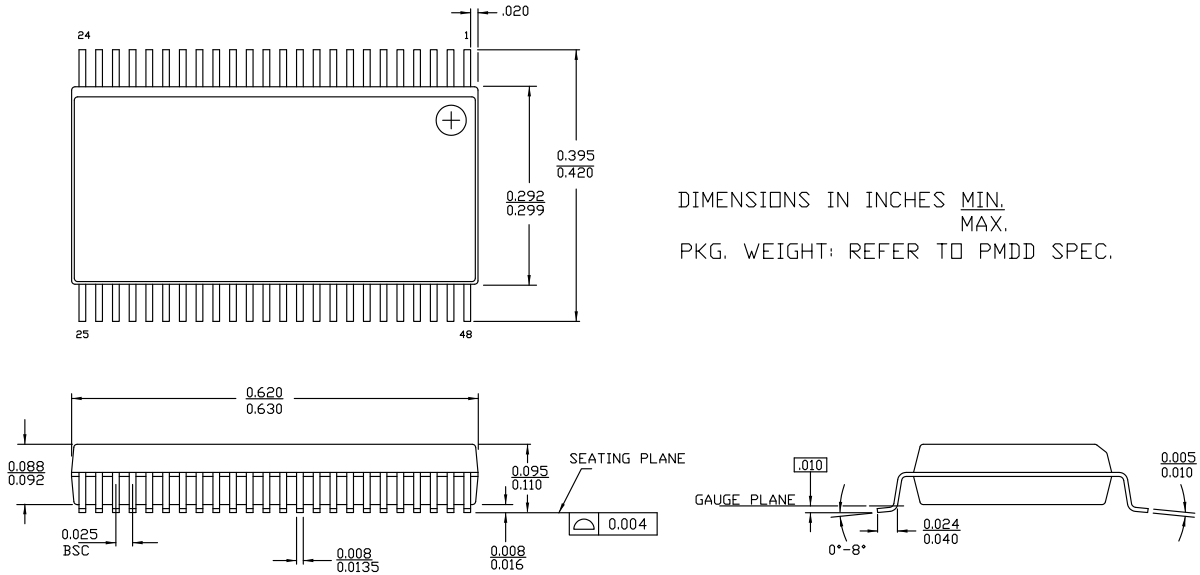

51-85061 \*F

Package Diagrams (continued)

Figure 16. 32-pin SOIC (300 Mil) Package Outline, 51-85127

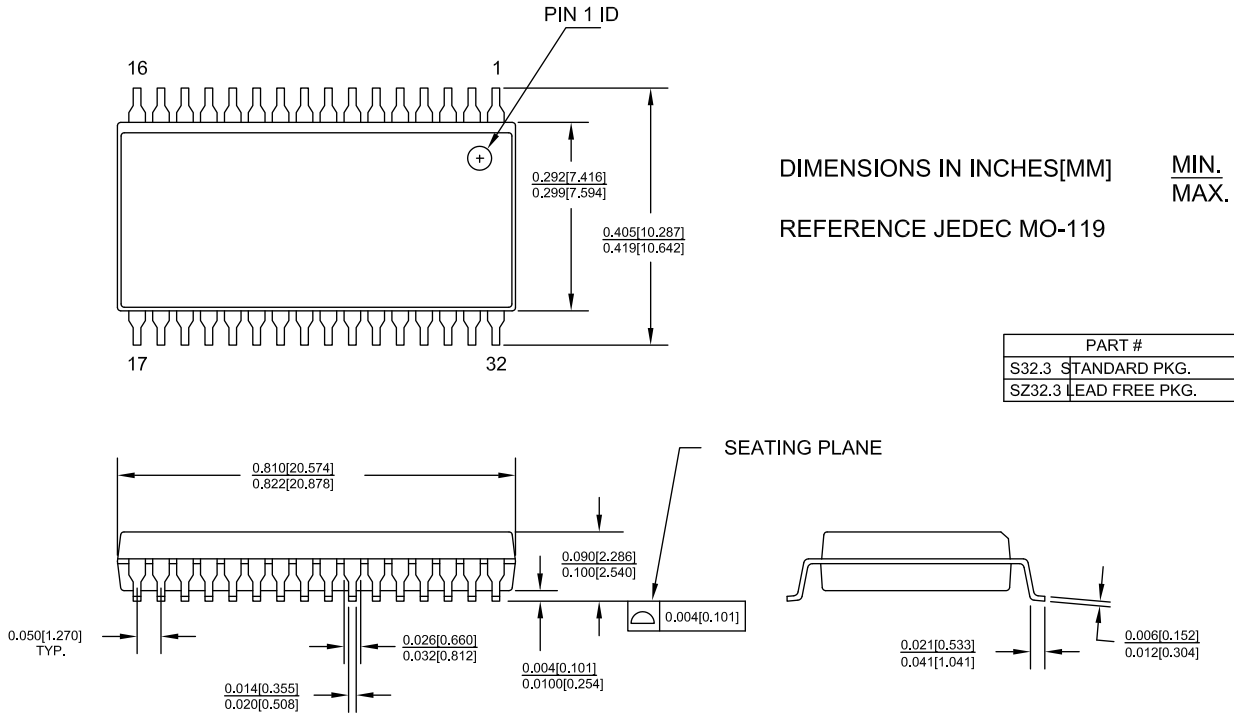

51-85127 \*D

## Acronyms

Acronym	Description
CE	chip enable
CMOS	complementary metal oxide semiconductor
EIA	electronic industries alliance
HSB	hardware store busy
I/O	input/output
nvSRAM	non-volatile static random access memory
OE	output enable
RoHS	restriction of hazardous substances
RWI	read and write inhibited
SRAM	static random access memory
SSOP	shrink small outline package
SOIC	small outline integrated circuit
TSOP	thin small outline package
WE	write enable

## Document Conventions

### Units of Measure

Symbol	Unit of Measure
°C	degree Celsius
kΩ	kilohm
MHz	megahertz
μA	microampere
μF	microfarad
μs	microsecond
mA	milliampere
ms	millisecond
ns	nanosecond
Ω	ohm
%	percent
pF	picofarad
V	volt
W	watt

**Document History Page**

Document Title: CY14B256LA, 256-Kbit (32 K × 8) nvSRAM Document Number: 001-54707			
Revision	ECN	Submission Date	Description of Change
**	2746918	07/31/2009	New data sheet.
*A	2772059	09/30/2009	Updated Software STORE, RECALL and Autostore Enable, Disable soft sequence
*B	2829117	12/16/09	Updated STORE cycles to QuantumTrap from 200K to 1 Million Updated 48-pin SSOP package diagram Added <a href="#">Contents</a> . Moved to external web
*C	2894560	03/18/10	Added more clarity on HSB pin operation Updated HSB pin operation in Figure 9 and updated footnote 21 Removed from ordering information table. CY14B256LA-ZS25XIT, CY14B256LA-ZS25XI, CY14B256LA-ZS45XIT, CY14B256LA-ZS45XI Updated <a href="#">Package Diagrams</a> for spec 51-85061 and 51-85087. Updated copyright section. Updated links under section sales, solutions, and legal information.
*D	2995066	07/28/2010	Added CY14B256LA-ZS25XI part to ordering information table.
*E	3074570	10/29/10	Added CY14B256LA-ZS25XIT part to ordering information table. Added <a href="#">Units of Measure</a> table
*F	3143330	01/17/2011	Fixed typo in <a href="#">Figure 9</a> .
*G	3315247	07/15/2011	Updated <a href="#">DC Electrical Characteristics</a> (Added <a href="#">Note 11</a> and referred the same note in $V_{CAP}$ parameter). Updated <a href="#">Capacitance</a> (Included Input capacitance (for $\overline{HSB}$ ) and Output capacitance (for HSB)). Updated <a href="#">Thermal Resistance</a> ( $\Theta_{JA}$ and $\Theta_{JC}$ values for 44-pin TSOP II packages). Updated <a href="#">AC Switching Characteristics</a> (Added <a href="#">Note 14</a> and referred the same note in Parameters).
*H	3430452	11/04/2011	Corrected alignment of footnote <a href="#">24</a> . Updated <a href="#">Package Diagrams</a> .
*I	3660776	06/29/2012	Updated <a href="#">DC Electrical Characteristics</a> (Added $V_{VCAP}$ parameter and its details, added <a href="#">Note 12</a> and referred the same note in $V_{VCAP}$ parameter, also referred <a href="#">Note 13</a> in $V_{VCAP}$ parameter).
*J	3759425	09/28/2012	Updated <a href="#">Maximum Ratings</a> (Removed “Ambient temperature with power applied” and included “Maximum junction temperature”). Updated <a href="#">Package Diagrams</a> (spec 51-85087 (Changed revision from *D to *E), spec 51-85061 (Changed revision from *E to *F)).
*K	4568935	11/14/2014	Added documentation related hyperlink in page 1
*L	6868237	04/25/2020	Updated to template. Updated Spec 51-85127 *C to *D in <a href="#">Package Diagrams</a> .

## Sales, Solutions, and Legal Information

### Worldwide Sales and Design Support

Cypress maintains a worldwide network of offices, solution centers, manufacturer's representatives, and distributors. To find the office closest to you, visit us at [Cypress Locations](#).

#### Products

Arm <sup>®</sup> Cortex <sup>®</sup> Microcontrollers	<a href="http://cypress.com/arm">cypress.com/arm</a>
Automotive	<a href="http://cypress.com/automotive">cypress.com/automotive</a>
Clocks & Buffers	<a href="http://cypress.com/clocks">cypress.com/clocks</a>
Interface	<a href="http://cypress.com/interface">cypress.com/interface</a>
Internet of Things	<a href="http://cypress.com/iot">cypress.com/iot</a>
Memory	<a href="http://cypress.com/memory">cypress.com/memory</a>
Microcontrollers	<a href="http://cypress.com/mcu">cypress.com/mcu</a>
PSoC	<a href="http://cypress.com/psoc">cypress.com/psoc</a>
Power Management ICs	<a href="http://cypress.com/pmic">cypress.com/pmic</a>
Touch Sensing	<a href="http://cypress.com/touch">cypress.com/touch</a>
USB Controllers	<a href="http://cypress.com/usb">cypress.com/usb</a>
Wireless Connectivity	<a href="http://cypress.com/wireless">cypress.com/wireless</a>

#### PSoC<sup>®</sup> Solutions

[PSoC 1](#) | [PSoC 3](#) | [PSoC 4](#) | [PSoC 5LP](#) | [PSoC 6 MCU](#)

#### Cypress Developer Community

[Community](#) | [Code Examples](#) | [Projects](#) | [Video](#) | [Blogs](#) | [Training](#) | [Components](#)

#### Technical Support

[cypress.com/support](http://cypress.com/support)



© Cypress Semiconductor Corporation, 2009-2020. This document is the property of Cypress Semiconductor Corporation and its subsidiaries ("Cypress"). This document, including any software or firmware included or referenced in this document ("Software"), is owned by Cypress under the intellectual property laws and treaties of the United States and other countries worldwide. Cypress reserves all rights under such laws and treaties and does not, except as specifically stated in this paragraph, grant any license under its patents, copyrights, trademarks, or other intellectual property rights. If the Software is not accompanied by a license agreement and you do not otherwise have a written agreement with Cypress governing the use of the Software, then Cypress hereby grants you a personal, non-exclusive, nontransferable license (without the right to sublicense) (1) under its copyright rights in the Software (a) for Software provided in source code form, to modify and reproduce the Software solely for use with Cypress hardware products, only internally within your organization, and (b) to distribute the Software in binary code form externally to end users (either directly or indirectly through resellers and distributors), solely for use on Cypress hardware product units, and (2) under those claims of Cypress's patents that are infringed by the Software (as provided by Cypress, unmodified) to make, use, distribute, and import the Software solely for use with Cypress hardware products. Any other use, reproduction, modification, translation, or compilation of the Software is prohibited.

TO THE EXTENT PERMITTED BY APPLICABLE LAW, CYPRESS MAKES NO WARRANTY OF ANY KIND, EXPRESS OR IMPLIED, WITH REGARD TO THIS DOCUMENT OR ANY SOFTWARE OR ACCOMPANYING HARDWARE, INCLUDING, BUT NOT LIMITED TO, THE IMPLIED WARRANTIES OF MERCHANTABILITY AND FITNESS FOR A PARTICULAR PURPOSE. No computing device can be absolutely secure. Therefore, despite security measures implemented in Cypress hardware or software products, Cypress shall have no liability arising out of any security breach, such as unauthorized access to or use of a Cypress product. CYPRESS DOES NOT REPRESENT, WARRANT, OR GUARANTEE THAT CYPRESS PRODUCTS, OR SYSTEMS CREATED USING CYPRESS PRODUCTS, WILL BE FREE FROM CORRUPTION, ATTACK, VIRUSES, INTERFERENCE, HACKING, DATA LOSS OR THEFT, OR OTHER SECURITY INTRUSION (collectively, "Security Breach"). Cypress disclaims any liability relating to any Security Breach, and you shall and hereby do release Cypress from any claim, damage, or other liability arising from any Security Breach. In addition, the products described in these materials may contain design defects or errors known as errata which may cause the product to deviate from published specifications. To the extent permitted by applicable law, Cypress reserves the right to make changes to this document without further notice. Cypress does not assume any liability arising out of the application or use of any product or circuit described in this document. Any information provided in this document, including any sample design information or programming code, is provided only for reference purposes. It is the responsibility of the user of this document to properly design, program, and test the functionality and safety of any application made of this information and any resulting product. "High-Risk Device" means any device or system whose failure could cause personal injury, death, or property damage. Examples of High-Risk Devices are weapons, nuclear installations, surgical implants, and other medical devices. "Critical Component" means any component of a High-Risk Device whose failure to perform can be reasonably expected to cause, directly or indirectly, the failure of the High-Risk Device, or to affect its safety or effectiveness. Cypress is not liable, in whole or in part, and you shall and hereby do release Cypress from any claim, damage, or other liability arising from any use of a Cypress product as a Critical Component in a High-Risk Device. You shall indemnify and hold Cypress, its directors, officers, employees, agents, affiliates, distributors, and assigns harmless from and against all claims, costs, damages, and expenses, arising out of any claim, including claims for product liability, personal injury or death, or property damage arising from any use of a Cypress product as a Critical Component in a High-Risk Device. Cypress products are not intended or authorized for use as a Critical Component in any High-Risk Device except to the limited extent that (i) Cypress's published data sheet for the product explicitly states Cypress has qualified the product for use in a specific High-Risk Device, or (ii) Cypress has given you advance written authorization to use the product as a Critical Component in the specific High-Risk Device and you have signed a separate indemnification agreement.

Cypress, the Cypress logo, Spansion, the Spansion logo, and combinations thereof, WICED, PSoC, CapSense, EZ-USB, F-RAM, and Traveo are trademarks or registered trademarks of Cypress in the United States and other countries. For a more complete list of Cypress trademarks, visit [cypress.com](http://cypress.com). Other names and brands may be claimed as property of their respective owners.

## Looking for pricing, stock, or lifecycle information?

Click below to explore more details on WIN SOURCE:

-  [View CY14B256LA-SP45XIT on WIN SOURCE](#)
-  [Infineon Technologies](#) Information

## Optimize Your Supply Chain with WIN SOURCE Solutions

-  Global Sourcing Solution
-  Obsolete Management
-  Cost Control Management
-  Shortage Management
-  Alternative Solution
-  Excess Inventory Management