



**THE DATASHEET OF  
LTC4282IUH#TRPBF**



# High Current Hot Swap Controller with I<sup>2</sup>C Compatible Monitoring

## FEATURES

- Allows Safe Board Insertion Into Live Backplane
- 12-/16-Bit ADC with ±0.9% Total Unadjusted Error
- Monitors Current, Voltage, Power and Energy
- Controls Two Parallel N-Channel MOSFETs for SOA Sharing in High Current Applications
- Internal EEPROM for Nonvolatile Configuration
- Wide Operating Voltage Range: 2.9V to 33V
- I<sup>2</sup>C/SMBus Digital Interface (Coexists with PMBus Devices)
- 12V Gate Drive for Lower MOSFET R<sub>DS(ON)</sub>
- Programmable Current Limit with 2% Accuracy
- MOSFET Power Limiting with Current Foldback
- Continuously Monitors MOSFET Health
- Stores Minimum and Maximum Measurements
- Alerts When Alarm Thresholds Exceeded
- Input Overvoltage and Undervoltage Protection
- Internal ±5% or External Timebases
- 32-Pin 5mm × 5mm QFN Package
- AEC-Q100 Qualified for Automotive Applications

## APPLICATIONS

- Enterprise Servers and Data Storage Systems
- Network Routers and Switches
- Base Stations
- Platform Management

## DESCRIPTION

The **LTC<sup>®</sup>4282** hot swap controller allows a board to be safely inserted and removed from a live backplane. Using one or more external N-channel pass transistors, board supply voltage and inrush current are ramped up at an adjustable rate. An I<sup>2</sup>C interface and onboard ADC allows for monitoring of board current, voltage, power, energy and fault status.

The device features analog foldback current limiting and supply monitoring for applications from 2.9V to 33V. Dual 12V gate drive allows high power applications to either share safe operating area across parallel MOSFETs or support a 2-stage start-up that first charges the load capacitance followed by enabling a low on-resistance path to the load.

The LTC4282 is well suited to high power applications because the precise monitoring capability and accurate current limiting reduce the extremes in which both loads and power supplies must safely operate. Non-volatile configuration allows for flexibility in the autonomous generation of alerts and response to faults.

All registered trademarks and trademarks are the property of their respective owners. Patents pending.

## TYPICAL APPLICATION

12V, 100A Plug-In Board Application

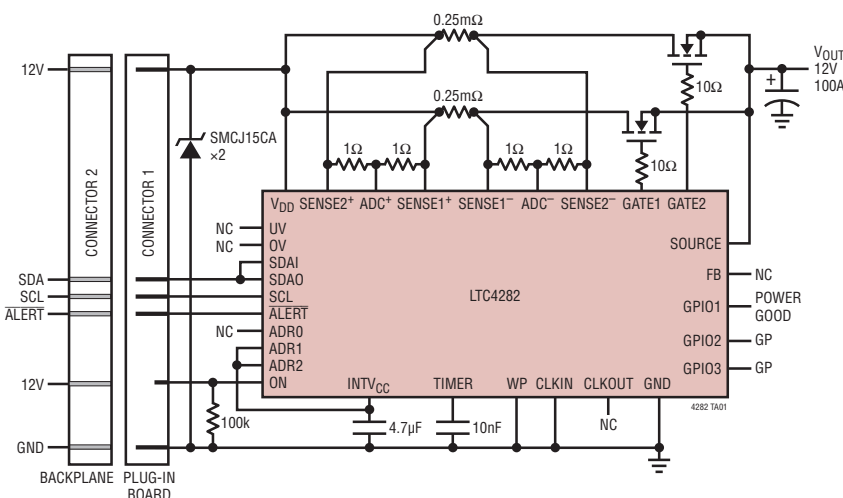

Start-Up Waveforms

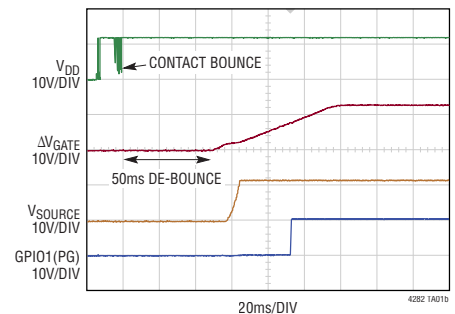

## TABLE OF CONTENTS

<b>Features</b> .....	<b>1</b>	FET Short Fault .....	22
<b>Applications</b> .....	<b>1</b>	Power Bad Fault.....	22
<b>Typical Application</b> .....	<b>1</b>	Fault Alerts .....	22
<b>Description</b> .....	<b>1</b>	Resetting Faults in FAULT_LOG .....	23
<b>Absolute Maximum Ratings</b> .....	<b>3</b>	Reboot.....	23
<b>Order Information</b> .....	<b>3</b>	Data Converters.....	23
<b>Electrical Characteristics</b> .....	<b>3</b>	CLKIN, CLKOUT: Crystal Oscillator/External Clock..	25
<b>Pin Configuration</b> .....	<b>3</b>	Configuring the GPIO Pins .....	25
<b>Timing Diagram</b> .....	<b>6</b>	Supply Transients .....	26
<b>Typical Performance Characteristics</b> .....	<b>7</b>	Design Example .....	26
<b>Pin Functions</b> .....	<b>9</b>	Layout Considerations .....	28
<b>Functional Diagram</b> .....	<b>11</b>	Digital Interface .....	29
<b>Operation</b> .....	<b>12</b>	START and STOP Conditions .....	29
<b>Applications Information</b> .....	<b>13</b>	I <sup>2</sup> C Device Addressing .....	29
Turn-On Sequence .....	13	Acknowledge .....	29
Turn-Off Sequence.....	14	Write Protocol.....	29
Current Limit Adjustment.....	15	Read Protocol .....	29
Constant Current Start-Up Using GATE R-C		Data Synchronization.....	31
Networks .....	15	Alert Response Protocol .....	31
Current Limit Stability.....	15	EEPROM .....	31
Parasitic MOSFET Oscillations.....	15	<b>Register Set</b> .....	<b>33</b>
Overcurrent Fault .....	16	<b>Detailed I<sup>2</sup>C Command Register Descriptions</b> .....	<b>34</b>
Advantages of Dual Gate Drivers .....	16	<b>Typical Applications</b> .....	<b>46</b>
Overvoltage Fault.....	17	<b>Package Description</b> .....	<b>48</b>
Undervoltage Fault.....	20	<b>Revision History</b> .....	<b>49</b>
ON/OFF Control.....	20	<b>Typical Application</b> .....	<b>50</b>
FET Bad Fault.....	21	<b>Related Parts</b> .....	<b>50</b>

## ABSOLUTE MAXIMUM RATINGS

(Notes 1, 2)

Supply Voltage  $V_{DD}$  ..... -0.3V to 45V

Input Voltages

GATE $n$  – SOURCE (Note 3) ..... -0.3V to 10VSENSE $n^+$ , ADC $^+$ ,SENSE1 $^-$  .....  $V_{DD} - 4.5V$  to  $V_{DD} + 0.3V$ SENSE2 $^-$ , ADC $^-$  ..... -0.3V to  $V_{DD} + 0.3V$ 

SOURCE ..... -0.3V to 45V

ADRO-2, TIMER ..... -0.3V to  $INTV_{CC} + 0.3V$ 

CLKIN ..... -0.3V to 5.5V

UV, OV, FB, WP, ON, GPIO1-3,

SCL, SDAI ..... -0.3V to 45V

Output Voltages

INTV $_{CC}$  ..... -0.3V to 5.5V

GATE1,2, GPIO1-3, ALERT, SDAO ..... -0.3V to 45V

CLKOUT ..... -0.3V to  $INTV_{CC} + 0.3V$ Output Current INTV $_{CC}$  ( $V_{DD} > 4V$ ) ..... 25mA

Operating Ambient Temperature Range

LTC4282C ..... 0°C to 70°C

LTC4282I ..... -40°C to 85°C

Storage Temperature Range ..... -65°C to 125°C

## PIN CONFIGURATION

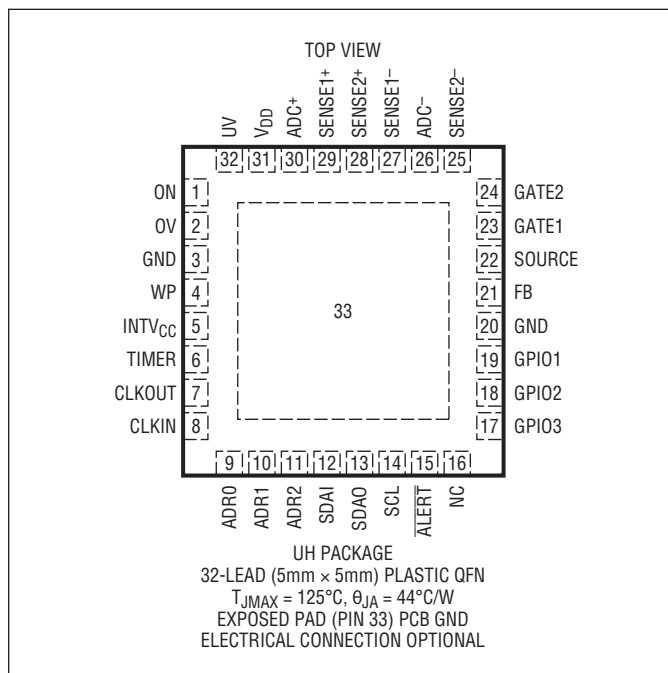

## ORDER INFORMATION

TUBE	TAPE AND REEL	PART MARKING	PACKAGE DESCRIPTION	TEMPERATURE RANGE
LTC4282AUH#PBF	LTC4282AUH#TRPBF	4282	32-Lead (5mm × 5mm) Plastic QFN	-40°C to 85°C

Contact the factory for parts specified with wider operating temperature ranges. [Tape and reel specifications](#). Some packages are available in 500 unit reels through designated sales channels with #TRMPBF suffix.

## ELECTRICAL CHARACTERISTICS

The ● denotes the specifications which apply over the full operating temperature range, otherwise specifications are at  $T_A = 25^{\circ}C$ .  $V_{DD} = 12V$  unless otherwise noted.

SYMBOL	PARAMETER	CONDITIONS	MIN	TYP	MAX	UNITS
<b>Supplies</b>						
$V_{DD}$	Input Supply Range		● 2.9		33	V
$I_{DD}$	Input Supply Current		●	3.5	8	mA
$V_{DD(UVL)-RISING}$	Input Supply Undervoltage Lockout	$V_{DD}$ Rising	● 2.6	2.7	2.8	V
$V_{DD(UVL)-FALLING}$	Input Supply Undervoltage Lockout	$V_{DD}$ Falling	● 2.525	2.66	2.785	V
$V_{DD(HYST)}$	Input Supply Undervoltage Lockout Hysteresis			40		mV
INTV $_{CC}$	Internal Regulator Voltage		● 3.1	3.3	3.5	V
INTV $_{CC(UVL)}$	INTV $_{CC}$ Undervoltage Lockout	INTV $_{CC}$ Rising	● 2.45	2.6	2.75	V
INTV $_{CC}$	INTV $_{CC}$ Undervoltage Lockout	INTV $_{CC}$ Falling	● 2.275	2.49	2.7	V
INTV $_{CC(HYST)}$	INTV $_{CC}$ Undervoltage Lockout Hysteresis			110		mV

## ELECTRICAL CHARACTERISTICS

The ● denotes the specifications which apply over the full operating temperature range, otherwise specifications are at  $T_A = 25^\circ\text{C}$ .  $V_{DD} = 12\text{V}$  unless otherwise noted.

SYMBOL	PARAMETER	CONDITIONS	MIN	TYP	MAX	UNITS	
<b>Current Limit</b>							
$\Delta V_{\text{SENSE}}$	Current Limit Voltage DAC Zero-Scale	$V_{\text{FB}} = 1.3\text{V}$ , $I_{\text{LIM}} = 000$	● 12.1	12.5	12.9	mV	
		$V_{\text{FB}} = 0\text{V}$ , $I_{\text{LIM}} = 000$	● 3.2	3.75	4.3	mV	
	Current Limit Voltage DAC Full-Scale	$V_{\text{FB}} = 1.3\text{V}$ , $I_{\text{LIM}} = 111$	● 32.88	34.37	35.87	mV	
		$V_{\text{FB}} = 0\text{V}$ , $I_{\text{LIM}} = 111$	● 8.7	10.31	11.9	mV	
	Current Limit Voltage DAC INL		● -0.1	0	0.1	LSB	
	Fast Current Limit Comparator Offset		●	0	$\pm 15$	mV	
$\Delta V_{\text{SENSE}1} - \Delta V_{\text{SENSE}2}$	Offset Between Channel 1 and Channel 2	$V_{\text{SENSE}1,2^+} = 12\text{V}$	●	0	$\pm 0.35$	mV	
$I_{\text{SENSE}^-}$	SENSE <sup>-</sup> Pin Input Current	$V_{\text{SENSE}^-} = 12\text{V}$	●	0	$\pm 1$	$\mu\text{A}$	
$I_{\text{SENSE}^+}$	SENSE <sup>+</sup> Pin Input Current	$V_{\text{SENSE}^+} = 12\text{V}$	●	0	45	80	$\mu\text{A}$
<b>Gate Drive</b>							
$\Delta V_{\text{GATE\_OUT}}$	Gate Drive ( $V_{\text{GATE}} - V_{\text{SOURCE}}$ ) (Note 3)	$V_{\text{DD}} = 2.9\text{V}$ to $33\text{V}$ , $I_{\text{GATE}} = -1\mu\text{A}$	●	10	12.5	13.5	V
$I_{\text{GATE}}$	Gate Pull-Up Current	Gate On, $V_{\text{GATE}} = 0\text{V}$	●	-15	-20	-30	$\mu\text{A}$
	Gate Pull-Down Current	Gate Off, $V_{\text{GATE}} = 10\text{V}$	●	0.5	1.3	3	mA
	Gate Fast Pull-Down Current	$\Delta V_{\text{SENSE}} = 100\text{mV}$ , $\Delta V_{\text{GATE}} = 10\text{V}$		0.3	0.6	1.5	A
$t_{\text{PHL\_FAST}}$	SENSE1,2 <sup>+</sup> -SENSE1,2 <sup>-</sup> Overcurrent to GATE1,2 Low	$\Delta V_{\text{SENSE}} = 0\text{mV}$ Step to $100\text{mV}$ , $C = 10\text{nF}$	●		0.5	1	$\mu\text{s}$
$\Delta V_{\text{GATE\_TH}}$	$\Delta V_{\text{GATE}}$ FET Off Threshold		●	5	8	10	V
<b>Comparator Inputs</b>							
$V_{\text{TH-R}}$	$V_{\text{DD}}$ , SOURCE Rising Threshold Voltages for UV, Power Good (Note 6)	5%	● -3	-7.5	-12	%	
		10%	● -8	-12.5	-17	%	
		15%	● -13	-17.5	-22	%	
$V_{\text{TH-F}}$	$V_{\text{DD}}$ , SOURCE Falling Threshold Voltages for UV, Power Good (Note 6)	5%	● -8	-12.5	-17	%	
		10%	● -13	-17.5	-22	%	
		15%	● -18	-22.5	-27	%	
$V_{\text{TH-R}}$	$V_{\text{DD}}$ Rising Threshold Voltages for OV (Note 6)	5%	● 8	12.5	17	%	
		10%	● 13	17.5	22	%	
		15%	● 18	22.5	27	%	
$V_{\text{TH-F}}$	$V_{\text{DD}}$ Falling Threshold Voltages for OV (Note 6)	5%	● 3	7.5	12	%	
		10%	● 8	12.5	17	%	
		15%	● 13	17.5	22	%	
$V_{\text{TH-R}}$	UV, OV, FB, ON Rising Threshold		● 1.26	1.28	1.3	V	
$V_{\text{TH-F}}$	UV, OV, FB, ON Falling Threshold		● 1.197	1.237	1.277	V	
$V_{\text{HYST}}$	UV, OV, FB, ON Hysteresis			43		mV	
$I_{\text{IN}}$	UV, OV, FB, ON, WP Input Current	$V = 1.2\text{V}$	●	0	$\pm 1$	$\mu\text{A}$	
$V_{\text{TH}}$	FET-Bad Fault $V_{\text{DS}}$ Threshold		● 140	200	280	mV	
$V_{\text{TH-R}}$	WP Threshold Voltage	Rising	● 1.202	1.3	1.385	V	
$V_{\text{TH-F}}$	WP Threshold Voltage	Falling	● 1.2	1.28	1.35	V	
$V_{\text{HYST}}$	WP Hysteresis		●	20		mV	
$t_{\text{PHL}}$	Turn-Off Propagation Delay	ON, UV, OV Turn Off	● 10	25	45	$\mu\text{s}$	
$t_{\text{D}}$	Fast Turn-On Propagation Delay	ON Pin Turn On	● 10	25	45	$\mu\text{s}$	
	Debounced Turn-On Propagation Delay	UV, OV Pin Turn On	● 45	50	55	ms	
<b>Crystal Oscillator Pin Functions</b>							
$V_{\text{TH}}$	CLKIN Rising Threshold		● 0.4	1	2	V	
$f_{\text{MAX}}$	Maximum CLKIN Pin Input Frequency (Note 7)	Driven with External Clock	●		25	MHz	
$I_{\text{CLKIN}}$	CLKIN Input Current	$V = 0\text{V}$ to $3.3\text{V}$	●	-10	10	$\mu\text{A}$	
$I_{\text{CLKOUT}}$	CLKOUT Output Current	$V = 0\text{V}$ to $3.3\text{V}$	●	-150	150	$\mu\text{A}$	

## ELECTRICAL CHARACTERISTICS

The ● denotes the specifications which apply over the full operating temperature range, otherwise specifications are at  $T_A = 25^\circ\text{C}$ .  $V_{DD} = 12\text{V}$  unless otherwise noted.

SYMBOL	PARAMETER	CONDITIONS	MIN	TYP	MAX	UNITS	
<b>GPIO Pin Functions</b>							
$V_{TH-R}$	GPIO, $\overline{\text{ALERT}}$ Threshold	Rising	● 1.262	1.3	1.345	V	
$V_{TH-F}$	GPIO, $\overline{\text{ALERT}}$ Threshold	Falling	● 1.26	1.28	1.31	V	
$V_{HYST}$	GPIO, $\overline{\text{ALERT}}$ Hysteresis			20		mV	
$V_{OL}$	GPIO, $\overline{\text{ALERT}}$ Output Low Voltage	$I = 3\text{mA}$	●	0.3	0.4	V	
$I_{OH}$	GPIO, $\overline{\text{ALERT}}$ Leakage Current	$V = 33\text{V}$	●	0	$\pm 2$	$\mu\text{A}$	
$t_{PHL\_GPIO2}$	Stress Condition to GPIO2 Low Propagation	GATE Low or $V_{DS} = 1\text{V}$	●	5	13	30	$\mu\text{s}$
<b>TIMER Pin Functions</b>							
$V_{TH}$	TIMER Low Threshold	Falling	● 0.11	0.15	0.19	V	
	TIMER High Threshold	Rising	● 1.25	1.28	1.31	V	
$I_{TIMER}$	TIMER Pull-Up Current	$V = 0\text{V}$	●	-18	-20	-22	$\mu\text{A}$
	TIMER Pull-Down Current	$V = 1.3\text{V}$	●	3	5	7	$\mu\text{A}$
$D_{OC}$	Overcurrent Auto-Retry Duty Cycle		● 0.045	0.08	0.11	%	
<b>SOURCE, ADC Pin Currents</b>							
$I_{SOURCE}$	SOURCE Input Current	$V = 12\text{V}$	●	70	180	350	$\mu\text{A}$
$I_{ADC-}$	ADC <sup>-</sup> Input Current	$V = 33\text{V}$	●		0	$\pm 1$	$\mu\text{A}$
$I_{ADC+}$	ADC <sup>+</sup> Input Current	$V = 33\text{V}$	●		25	110	$\mu\text{A}$
ADC	Resolution (No Missing Codes)			12/16			Bits
$V_{OS}$	ADC Offset Error, Percent of Full-Scale		●			$\pm 0.25$	%
TUE	ADC Total Unadjusted Error (Note 5)	$\Delta V_{ADC}$ , SOURCE, $V_{DD}$ , GPIO POWER ENERGY (Internal Timebase) ENERGY (Crystal/External Timebase)	● ● ● ●			$\pm 0.9$ $\pm 1.0$ $\pm 5.1$ $\pm 1.0$	% % % %
FSE	ADC Full-Scale Error	$\Delta V_{ADC}$ , SOURCE, $V_{DD}$ , GPIO POWER ENERGY (Internal Timebase) ENERGY (Crystal/External Timebase)	● ● ● ●			$\pm 0.9$ $\pm 1.0$ $\pm 5.1$ $\pm 1.0$	% % % %
$V_{FS}$	ADC Full-Scale Range	$\Delta V_{ADC}$ SOURCE/ $V_{DD}$ 24V Range SOURCE/ $V_{DD}$ 12V Range SOURCE/ $V_{DD}$ 5V Range SOURCE/ $V_{DD}$ 3.3V Range GPIO			40 33.28 16.64 8.32 5.547 1.28		mV V V V V V
INL	ADC Integral Nonlinearity, 12-Bit Mode				0.2		LSB
$V_{FS}$	Alarm Threshold Full-Scale Range ( $256 \cdot V_{LSB}$ )	$\Delta V_{ADC}$ SOURCE/ $V_{DD}$ 24V Range SOURCE/ $V_{DD}$ 12V Range SOURCE/ $V_{DD}$ 5V Range SOURCE/ $V_{DD}$ 3.3V Range GPIO			40 33.28 16.64 8.32 5.547 1.28		mV V V V V V
$R_{GPIO}$	GPIO ADC Sampling Resistance	$V = 1.28$	●	1	2		M $\Omega$
$f_{CONV} = 1/t_{CONV}$	Conversion Rate, All ADC Channels	12-Bit Mode, Internal Clock 16-Bit Mode, Internal Clock	● ●	14.5 0.906	15.26 0.954	16 1	Hz Hz
<b>I<sup>2</sup>C Interface</b>							
$V_{ADR(H)}$	ADR $n$ Input High Threshold		●	INTV <sub>CC</sub> -0.8	INTV <sub>CC</sub> -0.5	INTV <sub>CC</sub> -0.2	V
$V_{ADR(L)}$	ADR $n$ Input Low Threshold		●	0.2	0.5	0.8	V
$I_{ADR(IN)}$	ADR $n$ Input Current	ADR = 0V, ADR = INTV <sub>CC</sub>	●			$\pm 80$	$\mu\text{A}$
$I_{ADR(IN,Z)}$	ADR $n$ Allowable Leakage in Open State		●			$\pm 3$	$\mu\text{A}$

## ELECTRICAL CHARACTERISTICS

The ● denotes the specifications which apply over the full operating temperature range, otherwise specifications are at  $T_A = 25^\circ\text{C}$ .  $V_{DD} = 12\text{V}$  unless otherwise noted.

SYMBOL	PARAMETER	CONDITIONS		MIN	TYP	MAX	UNITS
$V_{SDA,SCL(TH)}$	SDAI, SCL Input Threshold		●	1.5	1.7	2.0	V
$I_{SDA,SCL(OH)}$	SDAI, SCL Input Current	SCL, SDA = 5V	●			±1	μA
$V_{SDAO(OL)}$	SDAO Output Low Voltage	$I = 3\text{mA}$	●		0.3	0.4	V
$I_{SDAO(OH)}$	SDAO Pin Input Leakage Current	$V_{SDAO} = 33\text{V}$	●		0	±1	μA

### I<sup>2</sup>C Interface Timing

$f_{SCL(MAX)}$	Maximum SCL Clock Frequency		●	400	1000		kHz
$t_{BUF(MIN)}$	Bus Free Time Between START and STOP Conditions		●		0.12	1.3	μs
$t_{HD,STA(MIN)}$	Hold Time After (Repeated) START Condition		●		30	600	ns
$t_{SU,STA(MIN)}$	Repeated START Condition Set-Up Time		●		30	600	ns
$t_{SU,STO(MIN)}$	STOP Condition Set-Up Time		●		140	600	ns
$t_{HD,DATI(MIN)}$	Data Hold Time (Input)		●		30	100	ns
$t_{HD,DATO}$	Data Hold Time (Output)		●	300	500	900	ns
$t_{SU,DAT(MIN)}$	Data Set-Up Time		●		30	100	ns
$t_{SP(MAX)}$	Suppressed Spike Pulse Width Maximum		●	50	110	250	ns
$C_X$	SCL, SDA Input Capacitance	(Note 4)	●			10	pF
$t_{D-STUCK}$	I <sup>2</sup> C Stuck Bus Timeout		●	25	30	35	ms

### EEPROM Characteristics

Endurance		1 Cycle = 1 Write (Notes 8, 9)	●	10,000			Cycles
Retention		(Notes 8, 9)	●	20			Years
$t_{WRITE}$	Write Operation Time		●	1	2.2	4	ms

**Note 1:** Stresses beyond those listed under Absolute Maximum Ratings may cause permanent damage to the device. Exposure to any Absolute Maximum Rating condition for extended periods may affect device reliability and lifetime.

**Note 2:** All currents into pins are positive. All voltages are referenced to GND unless otherwise specified.

**Note 3:** An internal clamp limits the GATE pin to a minimum of 10V above SOURCE. Driving this pin to voltages beyond the clamp may damage the device.

**Note 4:** Guaranteed by design and not subject to test.

**Note 5:** TUE is the maximum ADC error for any code, given as a percentage of full scale.

**Note 6:** UV, OV and FB internal thresholds are given as a percent difference from the configured operating voltage.

**Note 7:** CLKIN is tested to 25MHz, but the maximum clock that can be accepted without affecting performance is 15.5MHz.

**Note 8:** EEPROM endurance and retention are guaranteed by design, characterization and correlation with statistical process controls.

**Note 9:** EEPROM endurance and retention will be degraded when  $T_J > 85^\circ\text{C}$ .

## TIMING DIAGRAM

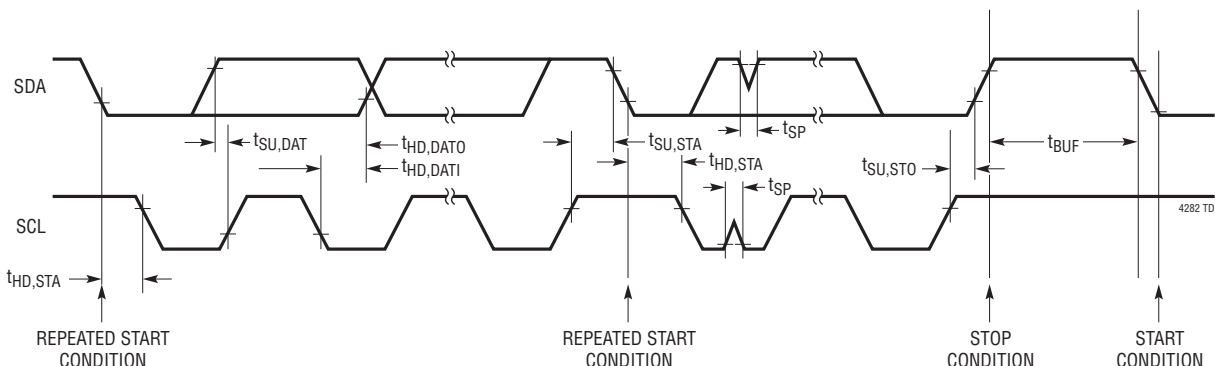

**TYPICAL PERFORMANCE CHARACTERISTICS**  $T_A = 25^\circ\text{C}$ ,  $V_{DD} = 12\text{V}$  unless otherwise noted.

**Supply Current vs Voltage**

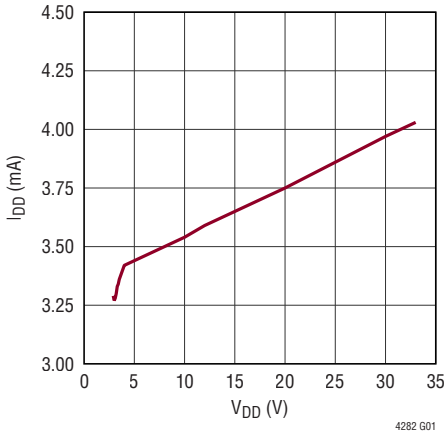

4282 G01

**3.3V Output Supply vs Voltage**

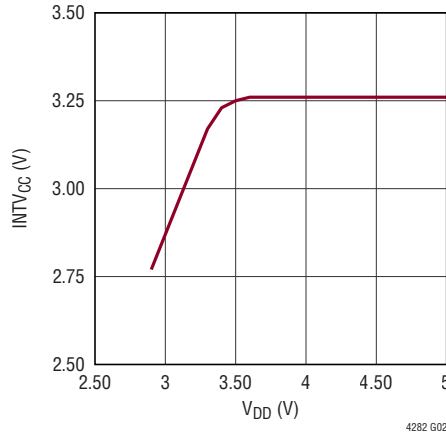

4282 G02

**3.3V Output Supply vs Load Current for  $V_{DD} = 12\text{V}$**

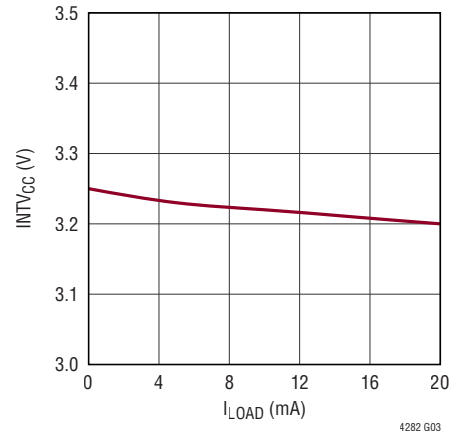

4282 G03

**Current Limit Foldback Profile**

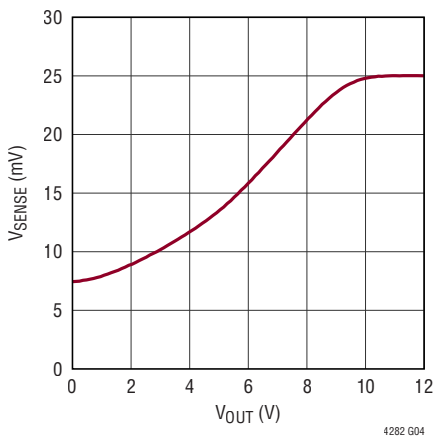

4282 G04

**MOSFET Power Limit**

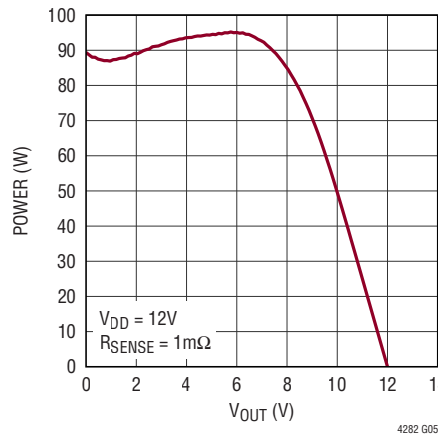

4282 G05

**Current Limit Threshold vs Temperature**

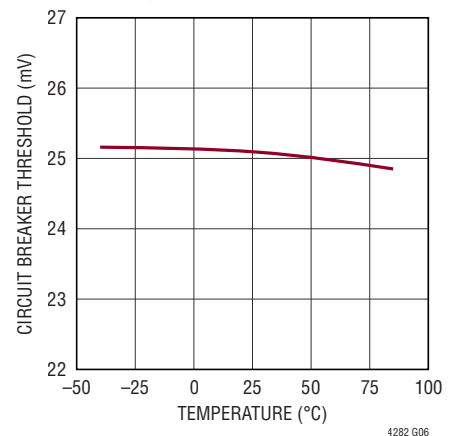

4282 G06

**Current Limit Propagation Delay vs Overdrive**

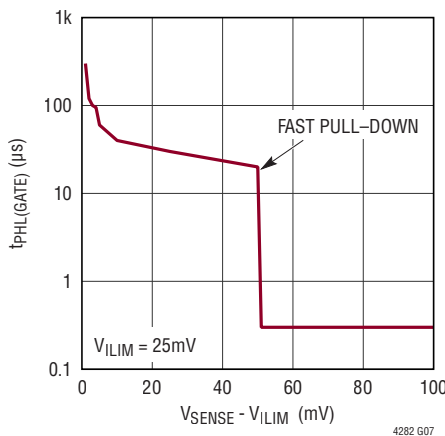

4282 G07

**External MOSFET Gate Drive vs Temperature**

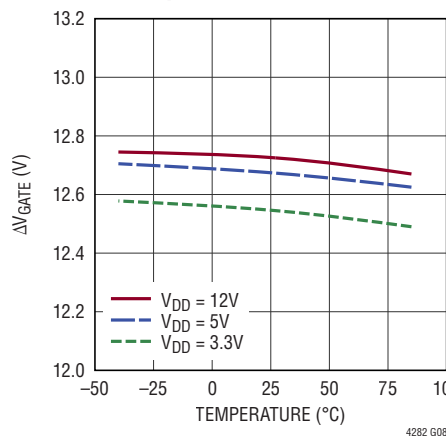

4282 G08

**External MOSFET Gate Drive vs Leakage Current**

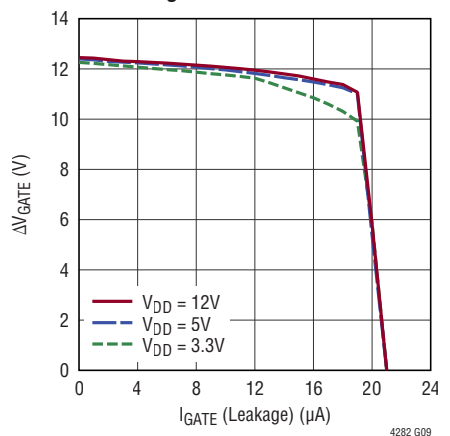

4282 G09

## TYPICAL PERFORMANCE CHARACTERISTICS

**External MOSFET Gate Drive Current vs Temperature ( $I_{GATE}$  Current vs Temperature)**

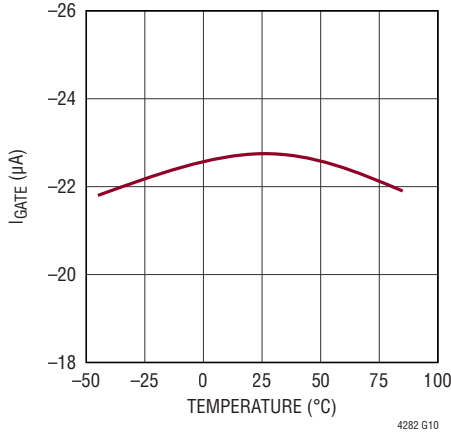

**GPIO Pin Output Low Voltage vs Load ( $V_{OL(GPIO)}$  vs  $I_{GPIO}$ )**

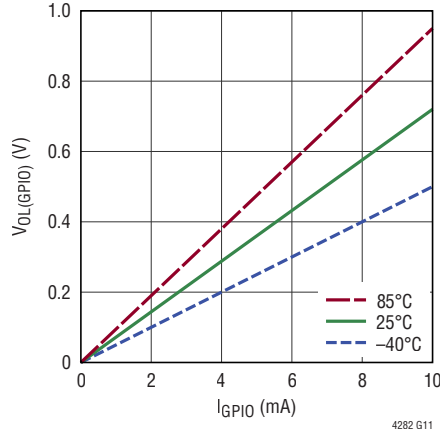

**ADC Total Unadjusted Error vs Code (TUE vs Code)**

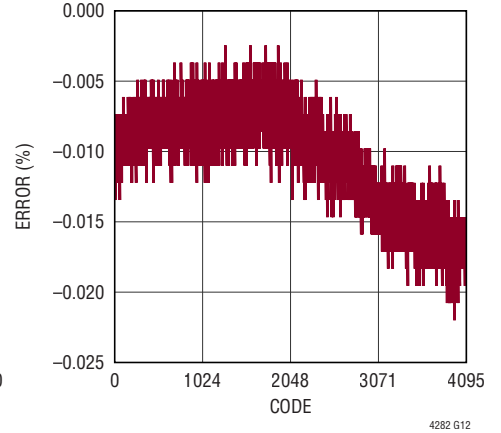

**ADC Integral Non-Linearity vs Code (INL vs Code)**

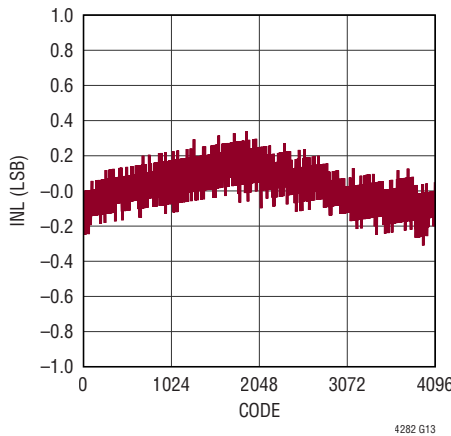

**ADC Differential Non-Linearity vs Code (DNL vs Code)**

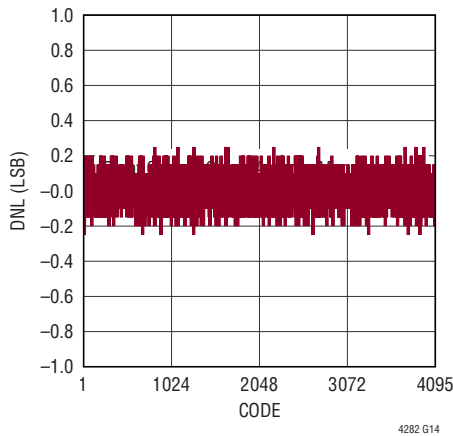

**ADC Full-Scale Error vs Temperature ( $V_{FSE}$  vs Temp.)**

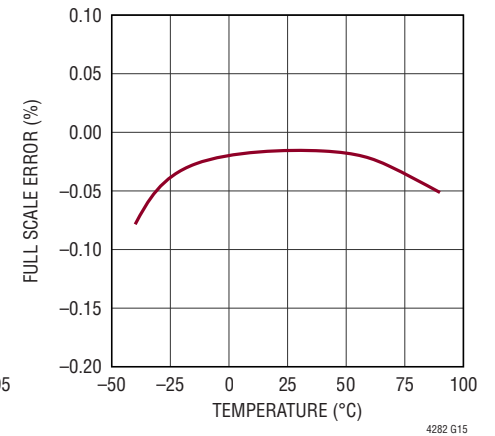

**16 Bit GPIO ADC Noise Histogram**

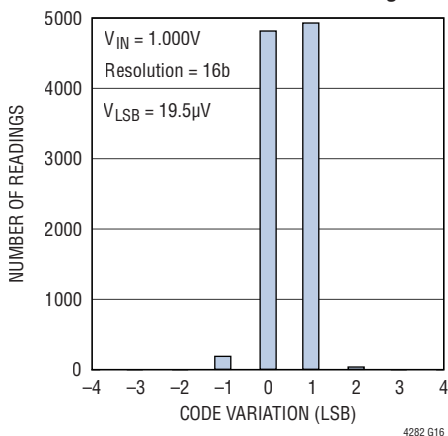

**16 Bit Current ADC Noise Histogram**

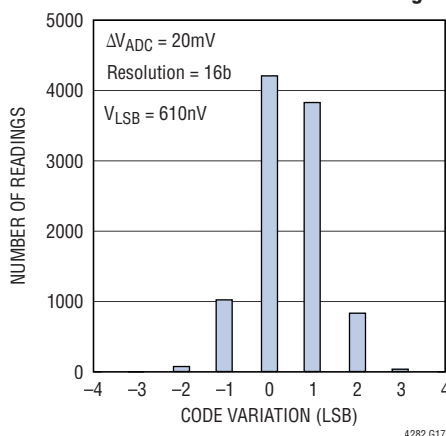

**12 Bit GPIO ADC Noise Histogram**

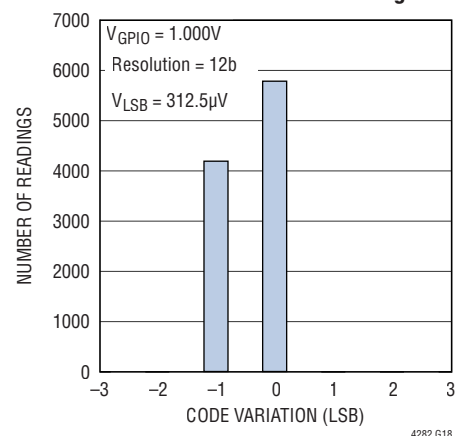

## PIN FUNCTIONS

**ADC<sup>+</sup>:** Positive Kelvin ADC Current Sense Input. Use a resistive divider between the two SENSE<sup>+</sup> pins to measure the average of the two SENSE<sup>+</sup> voltages. Tie to SENSE1<sup>+</sup> when using a single sense resistor. Must be connected to the same trace as V<sub>DD</sub> or a resistive averaging network which adds up to 1Ω to V<sub>DD</sub>.

**ADC<sup>-</sup>:** Negative Kelvin ADC Current Sense Input. Use a resistive divider between the two SENSE<sup>-</sup> pins to measure the average of the two SENSE<sup>-</sup> voltages. Tie to SENSE1<sup>-</sup> when using a single sense resistor.

**ADR0-ADR2:** Serial Bus Address Inputs. Tying these pins to ground (L), open (NC), or INTV<sub>CC</sub> (H) configures one of 27 possible addresses. See Table 1 in Applications Information.

**ALERT:** I<sup>2</sup>C Bus  $\overline{\text{ALERT}}$  Output or General Purpose Input/Output. Configurable to  $\overline{\text{ALERT}}$  output, general purpose output or logic input. Tie to ground if unused.

**CLKIN:** Clock Input. Connect to an optional external 4MHz crystal oscillator circuit or drive with an external clock up to 15.5MHz. Connect to ground if unused.

**CLKOUT:** Clock Output. Connect to an optional external crystal oscillator circuit. Can be configured in non-volatile memory to output the internal clock or a low pulse when the ADC finishes a conversion. Float if unused.

**FB:** Foldback Current Limit and Power Good Input. A resistive divider from the output is tied to this pin. When the voltage at this pin drops below 1.28V, power is not considered good. The power bad condition may result in the GPIO1 pin pulling low or going high impedance depending on the configuration of GPIO\_CONFIG register 0x07 bits 4 and 5, also a power bad fault is logged in this condition if the GATE pin is high. The start-up current limit folds back to 30% as the FB pin voltage drops from 1.3V to 0V.

**GATE1, GATE2:** Gate Drives for External N-Channel MOSFETs. Internal 20μA current sources charge the gates of the MOSFETs. No compensation capacitors are required on the GATE pins, but a resistor and capacitor network from these pins to ground may be used to set the turn-on output voltage slew rate. During turn-off there is a 1mA pull-down current. During a short-circuit or undervoltage lockout (V<sub>DD</sub> or INTV<sub>CC</sub>), a 600mA pull-down between GATE1/GATE2 and SOURCE is activated. Tie both GATE pins together if only one MOSFET is used and SENSE2<sup>-</sup> is grounded.

**GND:** Device Ground.

**GPIO1:** General Purpose Input/Open-Drain Output. Configurable to general purpose output, logic input, and power good or power bad signal. Tie to ground if unused.

**GPIO2:** General Purpose Input/Open-Drain Output. Configurable to general purpose output, logic input, MOSFET stress output, and data converter input. Tie to ground if unused.

**GPIO3:** General Purpose Input/Open-Drain Output. Configurable to general purpose output, logic input, and data converter input. Tie to ground if unused.

**INTV<sub>CC</sub>:** 3.3V Supply Decoupling Output. Connect a 1μF capacitor from this pin to ground. To ensure fault logging after power is lost a 4.7μF capacitor should be used. 25mA may be drawn from this pin to power 3.3V application circuitry. Increase capacitance by 1μF/mA external load when fault logging is used. This pin should not be driven and is not current limited.

**NC:** No Connect.

**ON:** On Control Input. Used to monitor a connection sense pin on the backplane connector. The default polarity is high = on, but may be reconfigured to low = on by setting CONTROL1 register 0x00 bit 5 low. An on-to-off transition on this pin clears the fault register if CONTROL register 0x00 bit 7 is set high. The ON pin has a precise 1.28V threshold, allowing it to double as a supply monitor.

## PIN FUNCTIONS

**OV:** Overvoltage Input Pin. An overvoltage condition is present whenever this pin is above the configured threshold. Connect a resistive divider when the internal divider is disabled, otherwise leave open.

**SCL:** Serial Bus Clock Input. Data at the SDA pin is shifted in or out on rising edges of SCL. This is a high impedance pin that is driven by an open-drain output from a master controller. An external pull-up resistor or current source is required.

**SDAI:** Serial Bus Data Input. A high impedance input for shifting in address, command or data bits. Normally tied to SDAO to form the SDA line.

**SDAO:** Serial Bus Data Output. Open-drain output for sending data back to the master controller or acknowledging a write operation. Normally tied to SDAI to form the SDA line. An external pull-up resistor or current source is required.

**SENSE1<sup>+</sup>, SENSE2<sup>+</sup>:** Positive Kelvin Current Sense Input. Connect this pin to the input side of the current sense resistor or an averaging network in the case of multiple sense resistors. The parallel resistance of an averaging network should not exceed 1 $\Omega$ . Must operate at the same potential as  $V_{DD}$ .

**SENSE1<sup>-</sup>, SENSE2<sup>-</sup> :** Negative Kelvin Current Sense Input. Connect this pin to the output side of the current sense resistor. The current limit circuit controls the GATE pin to limit the sense voltage between the SENSE<sup>+</sup> and

SENSE<sup>-</sup> pins to the value selected in the ILIM register or less. Tie SENSE2<sup>-</sup> to GND when unused.

**SOURCE:** N-Channel MOSFET Source and ADC Input. Connect this pin to the source of the external N-channel MOSFET. This pin provides a return for the GATE pull-down circuit and also serves as the ADC input to monitor the output voltage.

**TIMER:** Current Limit and Retry Timer Input. Connect a capacitor between this pin and ground to set a 64ms/ $\mu$ F duration for current limit, after which an overcurrent fault is logged and GATE is pulled low. The duration of the off time is 73s/ $\mu$ F when overcurrent auto-retry is enabled, resulting in a 0.08% duty cycle.

**UV:** Undervoltage Input Pin. Connect a resistive divider when the internal divider is disabled. A capacitor may be placed on this pin to filter brief UV glitches on the input supply.

**V<sub>DD</sub>:** Supply Voltage Input and UV/OV Input. This pin has an undervoltage lockout threshold of 2.7V. The UV and OV thresholds are also measured at this pin, and the ADC may be configured to read the voltage at this pin.

**WP:** EEPROM Write Protect. All writes to the EEPROM except fault logging are blocked when WP is high.

FUNCTIONAL DIAGRAM

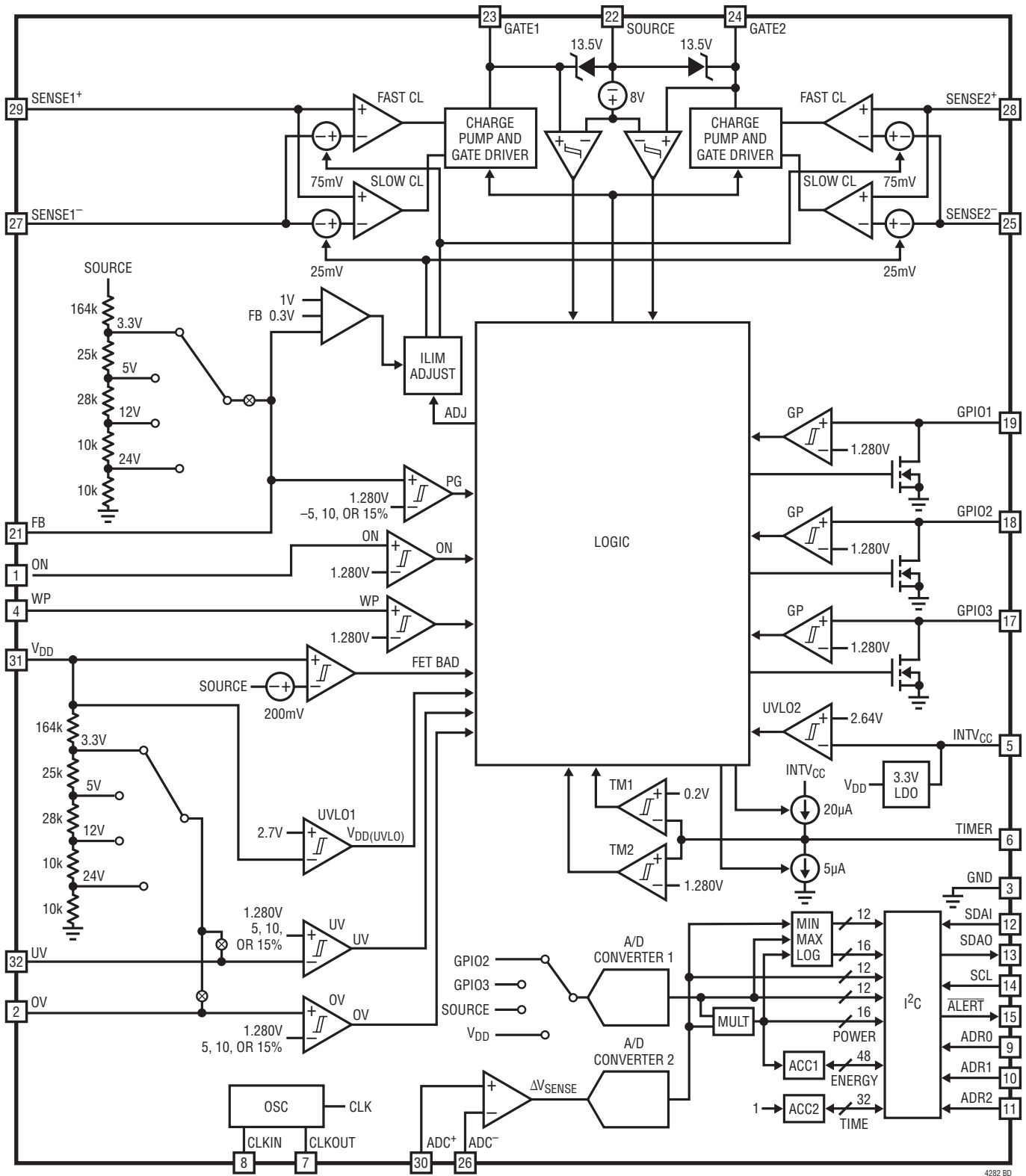

4282 BD

## OPERATION

The LTC4282 is designed to turn a board's supply voltage on and off in a controlled manner, allowing the board to be safely inserted or removed from a live backplane. During normal operation, the gate drivers turn on a pair of parallel external N-channel MOSFETs to pass power to the load. The gate driver charge pumps derive their power from the  $V_{DD}$  pin. Also included in the gate drivers are 12.5V GATE-to-SOURCE clamps to protect the oxide of external MOSFETs. During start-up the inrush current is tightly balanced and controlled by using current limit foldback.

Two MOSFETs are used to double the SOA and halve the  $R_{DS(ON)}$  as compared to a single MOSFET. The current limit (CL) amplifiers monitor the load current with current sense resistors connected between the SENSE1<sup>+</sup>, SENSE2<sup>+</sup> and SENSE1<sup>-</sup>, SENSE2<sup>-</sup> pins. The CL amplifiers limit the current in the load by pulling back on the GATE-to-SOURCE voltages in an active control loop when the sense voltages exceed the commanded value.

An overcurrent fault at the output may result in excessive MOSFET power dissipation during active current limiting. To limit this power, the CL amplifiers regulate the voltage between the SENSE1<sup>+</sup>, SENSE2<sup>+</sup> and SENSE1<sup>-</sup>, SENSE2<sup>-</sup> pins at the value set in the ILIM register. When the output (SOURCE pin) is low, power dissipation is further reduced by folding back the current limit to 30% of nominal.

The TIMER pin ramps up with 20 $\mu$ A when both current limit circuits are active. The LTC4282 turns off both GATES and registers a fault when the TIMER pin reaches its 1.28V threshold. At this point the TIMER pin ramps down using a 5 $\mu$ A current source until the voltage drops below 0.2V (comparator TM1). The TIMER pin will then ramp up and down 256 times with 20 $\mu$ A/5 $\mu$ A before indicating that the external MOSFET has cooled and it is safe to turn on again, provided overcurrent auto-retry is enabled.

The output voltage is monitored using the SOURCE pin and the power good (PG) comparator to determine if the power is available for the load. The power good condition can be signaled by the GPIO1 pin. The GPIO1 pin may also be configured to signal power bad, as a general purpose input (GP comparator), or a general purpose open-drain output.

GPIO2 and GPIO3 may also be configured as general purpose inputs or general purpose open-drain outputs. Additionally the ADC measures these pins with a 1.28V full-scale. GPIO2 may be configured to pull low to indicate that the external MOSFETs are in a state of stress when the MOSFETs are commanded to be on and either the gate voltages are lower than they should be, or the drain-to-source voltage exceeds 200mV.

The Functional Diagram shows the monitoring blocks of the LTC4282. The group of comparators on the left side includes the undervoltage (UV), overvoltage (OV), and (ON) comparators. These comparators determine if the external conditions are valid prior to turning on the GATES. But first the two undervoltage lockout circuits, UVLO1 and UVLO2, validate the input supply and the internally generated 3.3V supply, INTV<sub>CC</sub>. UVLO2 also generates the power-up initialization to the logic circuits and copies the contents of the EEPROM to operating memory after INTV<sub>CC</sub> crosses this rising threshold.

Included in the LTC4282 is a pair of 12-/16-bit A/D converters. One data converter continuously monitors the ADC<sup>+</sup> to ADC<sup>-</sup> voltage, sampling every 16 $\mu$ s and producing a 12-bit result of the average current sense voltage every 65ms. The other data converter is synchronized to the first one and measures the GPIO voltage and SOURCE voltage during the same time period. Every time the ADCs finish taking a measurement, the current sense voltage is multiplied by the measurement of the SOURCE pin to provide a power measurement. Every time power is measured, it is added to an energy accumulator which keeps track of how much energy has been transmitted to the load. The energy accumulator can generate an optional alert upon overflow, and can be pre-set to allow it to overflow after a given amount of energy has been transmitted. A time accumulator also keeps track of how many times the power meter has been incremented; dividing the results of the energy accumulator by the time accumulator gives the average system power. The minimum and maximum measurements of GPIO, SOURCE, ADC<sup>+</sup> to ADC<sup>-</sup> and power are stored, and optional alerts may be generated if a measurement is above or below user configurable 8-bit thresholds.

## OPERATION

An internal EEPROM provides nonvolatile configuration of the LTC4282's behavior, records fault information and provides 4 bytes of uncommitted memory for general purpose storage.

An I<sup>2</sup>C interface is provided to read the A/D data registers. It also allows the host to poll the device and determine if

faults have occurred. If the  $\overline{\text{ALERT}}$  pin is configured as an  $\overline{\text{ALERT}}$  interrupt, the host is enabled to respond to faults in real time. The I<sup>2</sup>C device address is decoded using the ADR0-ADR2 pins. These inputs have three states each that decode into a total of 27 device addresses, as shown in Table 1.

## APPLICATIONS INFORMATION

A typical LTC4282 application is a high availability system in which a positive voltage supply is distributed to power individual hot-swapped cards. The device measures card voltages and currents and records past and present fault conditions. The LTC4282 stores min and max ADC measurements, calculates power and energy, and can be configured to generate alerts based on measurement results, avoiding the need for the system to poll the device on a regular basis. The LTC4282 is configured with nonvolatile EEPROM memory, allowing it to be configured during board level testing and avoid having to configure the Hot Swap controller at every insertion.

A basic LTC4282 application circuit is shown in Figure 1. The following sections cover turn-on, turn-off and various

faults that the LTC4282 detects and acts upon. External component selection is discussed in detail in the Design Example section.

### Turn-On Sequence

The power supply on a board is controlled by using a pair of N-channel pass transistors, M1 and M2, placed in the power path. Resistors R<sub>S1</sub> and R<sub>S2</sub> sense current through M1 and M2. Resistors R12 to R15 provide a weighted average of the two sense voltages for ADC measurements. Resistors R1, R2 and R3 define undervoltage and overvoltage levels. R4 and R5 prevent high frequency self-oscillations in M1 and M2. Capacitors C4 and C5 form a resonator network with crystal Y1 to provide an accurate time base.

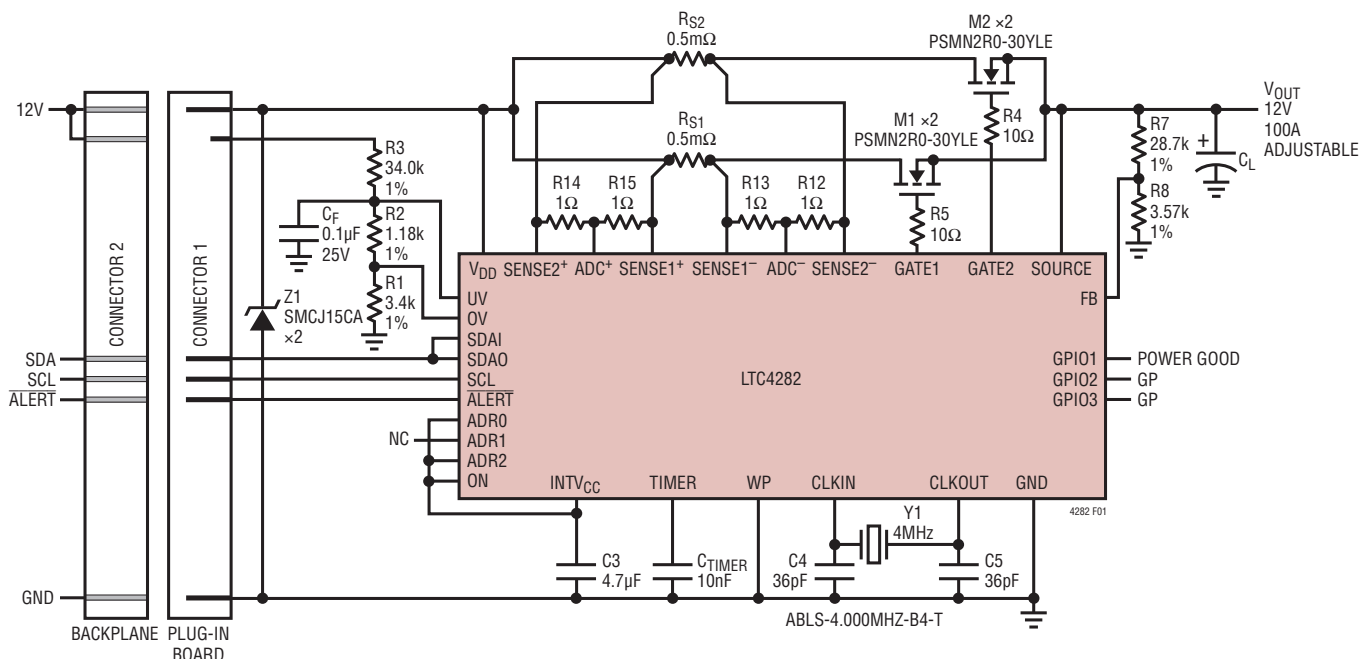

Figure 1. Typical Application

## APPLICATIONS INFORMATION

Several conditions must be present before the external MOSFET turns on. First the external supply,  $V_{DD}$ , must exceed its 2.7V undervoltage lockout level. Next the internally generated supply,  $INTV_{CC}$ , must cross its 2.6V undervoltage threshold. This generates a 1ms power-on-reset pulse. During reset the fault registers are cleared and the control registers are loaded with the data held in the corresponding EEPROM registers.

After a power-on-reset pulse, the UV and OV pins verify that input power is within the acceptable range. The state of the UV and OV comparators is indicated by STATUS register 0x1E bits 0 and 1 and must be stable for at least 50ms to qualify for turn-on. The ON pin is checked to see that a connection sense ("short") pin has asserted to the correct state. By default the ON pin has no delay, but a 50ms de-bounce delay may be added by setting CONTROL register 0x00 bit 6 high. When these conditions are satisfied, turn-on is initiated. Figure 10 shows connection sense configurations for both high- and low-going short pins. The ON pin has a precise 1.28V threshold, allowing it to also monitor a voltage through the short pin, such as a house-keeping or auxiliary supply delivered by the backplane. Use of the UV/OV divider for short pin detection in high current applications is not recommended, as voltage drops in the connector and fuse will impair the accuracy of the intended function.

The MOSFETs are then turned on by charging up the GATE pins with 20 $\mu$ A current sources. When the GATE pin voltage reaches the MOSFET threshold voltage, the MOSFET begins to turn on and the SOURCE voltage then follows the GATE voltages as it increases.

While the MOSFETs are turning on, the power dissipation in current limit for each MOSFET is limited to a fixed value by the foldback profile as shown in Figure 2. As the SOURCE voltage rises, the FB pin follows as set by R7 and R8. Once one of the GATE pins crosses its 8V  $V_{GATE}$  threshold and the FB pin has exceeded its 1.28V threshold, the GPIO1 pin (in its power-good configuration) releases high to indicate power is good and the load may be activated.

At the minimum input supply voltage of 2.9V, the minimum GATE-to-SOURCE drive voltage is 10V. The GATE-to-SOURCE voltage is clamped below 13.5V to

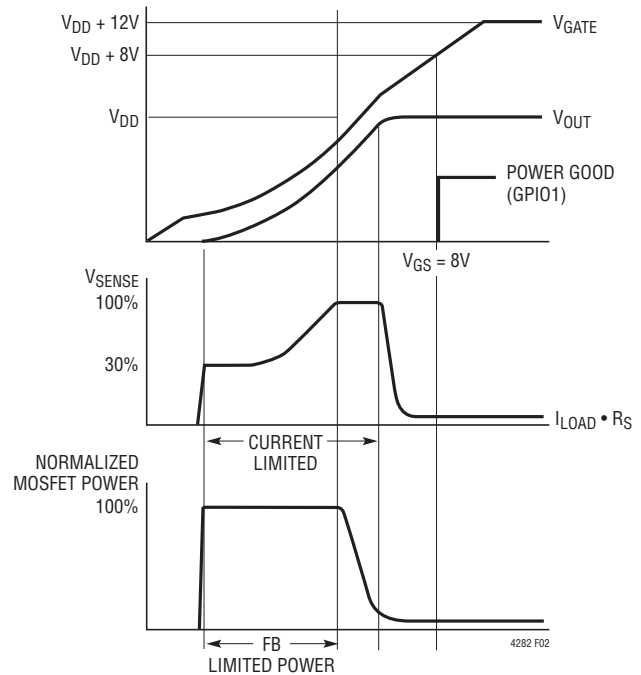

Figure 2. Power-Up Waveforms

protect the gates of 20V N-channel MOSFETs. A curve of GATE-to-SOURCE drive ( $\Delta V_{GATE}$ ) versus  $V_{DD}$  is shown in the Typical Performance Characteristics.

### Turn-Off Sequence

A normal turn-off sequence is initiated by card withdrawal when the backplane connector short pin opens, causing the ON pin to change state. Turn-off may be also initiated by writing a 0 to control register 0x00 bit 3. Additionally, several fault conditions turn off the GATE pins. These include an input overvoltage, input undervoltage, over-current or FET-BAD fault. Setting high any of the UV, OV, OC or FET-BAD fault bits 0-2 and 6 of the FAULT\_LOG register 0x04, also latches off the GATE pins if the associated auto-retry bits are set low.

The MOSFETs are turned off with 1mA currents pulling down the GATE pins to ground. With the MOSFET turned off, the SOURCE and FB voltages drop as the load capacitance discharges. When the FB voltage crosses below its threshold, GPIO1 pulls low to indicate that the output power is no longer good if configured to indicate power good. If the  $V_{DD}$  pin falls below 2.65V for greater than 2 $\mu$ s or  $INTV_{CC}$  drops below 2.45V for greater than 2 $\mu$ s, a fast

## APPLICATIONS INFORMATION

shut down of the MOSFET is initiated. The GATE pins are then pulled down with 600mA currents to the SOURCE pin.

### Current Limit Adjustment

The current limit sense voltage of the LTC4282 is adjustable between 12.5mV and 34.4mV in 3.1mV steps via the I<sup>2</sup>C interface with bits 7-5 of the ILIM\_ADJUST register 0x11. Default values are stored in the onboard EEPROM. This can be used to adjust the sense voltage to achieve a given current limit using the limited selection of standard sense resistor values available around 1mΩ. It also allows the LTC4282 to reduce available current for light loads or increase it in anticipation of a surge. This feature also enables the use of board-trace as sense resistors by trimming the sense voltage to match measured copper resistance during final test. The measured copper resistance may be written to the undedicated scratch pad area of the EEPROM so that it is available to scale ADC current measurements.

### Constant Current Start-Up Using GATE R-C Networks

An optional series resistor and capacitor network from GATE to GROUND ( $R_G$  and  $C_G$  in Figure 4) provides an inrush current less than the current limit by limiting the slew rate of the GATE pin, which pulls up with 20μA. The current limit timer will not run since the current limit is not engaged during startup so a small timer capacitor may be used, which allows the use of MOSFETs with smaller safe operating area. Power good will not signal until the FB pin crosses its threshold and the GATE-to-SOURCE voltages crosses their 8V thresholds which indicates the MOSFETs are fully enhanced. When both those conditions are met, the output voltage is suitable for the load to be turned on and the impedance back to the supply through the MOSFET is low. Power good is then asserted with the GPIO1 pin or read via the interface, signaling that it is safe to turn on downstream loads. A power-bad fault is not generated when starting up in this manner because the FB pin will cross its threshold before the GATE-to-SOURCE threshold is crossed.  $R_G$  should be chosen such that  $I_{GATE} \cdot R_G$  is less than the threshold of the MOSFET to avoid a current spike at the beginning of startup. Reducing  $R_G$  degrades the stability of the current limit circuit, see Applications Information on Current Limit Stability. If a

value of  $R_G$  is not found that produces a voltage less than the MOSFET threshold when the 20μA  $I_{GATE}$  current flows through it, while also producing a stable current limit servo loop,  $C_G$  may be charged with a diode during start-up in parallel with a large  $R_G$ , such as 500kΩ, to discharge it when the part turns off (see Figure 4). For the staged-start architectures, an RC must be used on a trickle MOSFET and may be used on a STRESS MOSFET. In the parallel architecture, identical RC networks may be used on both MOSFETs. Bypass MOSFETs don't need the current limiting function of an RC network, but an RC network may be used in low-stress staged start to improve the undershoot recovery time of the bypass MOSFET(s).

### Current Limit Stability

For most applications the LTC4282 current limit loop is stable without additional components. However there are certain conditions where additional components may be needed to improve stability. The dominant pole of the current limit circuit is set by the capacitance at the gate of the external MOSFET, and larger gate capacitance makes the current limit loop more stable. Usually a total of 8nF GATE-to-SOURCE capacitance is sufficient for stability and is provided by inherent MOSFET  $C_{GS}$ . The stability of the loop is degraded by reducing the size of the resistor on a gate RC network if one is used to limit start-up current as in Figure 4, which may necessitate additional GATE-to-SOURCE capacitance. Board level short-circuit testing is highly recommended as board layout can also affect transient performance. The worst-case condition for current limit stability occurs when the output is shorted to ground after a normal start-up.

### Parasitic MOSFET Oscillations

Not all circuit oscillations can be ascribed to the current limit loop. Some higher frequency oscillations can arise from the MOSFETs themselves. There are two possible parasitic oscillation mechanisms. The first type of oscillation occurs at high frequencies, typically above 1MHz. This high frequency oscillation is easily damped with gate resistors R4 and R5 as shown in Figure 1. In some applications, one may find that these resistors help in short-circuit transient recovery as well. However, too large of a resistor will slow down the turn-off time.

## APPLICATIONS INFORMATION

The recommended R4 and R5 range is between 5Ω and 500Ω. 10Ω provides stability without affecting turn-off time. These resistors must be located at the MOSFET package with no other components connected to the MOSFET gate pin.

A second type of parasitic oscillation occurs at frequencies between 200kHz and 800kHz when the MOSFET source is loaded with less than 10μF, and the drain is fed with an inductive impedance such as contributed by wiring inductance. To prevent this second type of oscillation load the source with more than 10μF and bypass the input supply with a series 10Ω, 100nF snubber to ground.

### Overcurrent Fault

The LTC4282 features an adjustable current limit with foldback that protects the MOSFETs from excessive load current. To protect the MOSFETs during active current limit, the available current is reduced as a function of the output voltage sensed by the FB pin such that the power dissipated by the MOSFET is constant. Graphs in the Typical Performance Characteristics show the current limit and power versus FB voltage.

An overcurrent fault occurs when the current limit circuitry has been engaged for both MOSFETs for longer than the timeout delay set by the TIMER capacitor. Current limiting begins when the current sense voltage between the SENSE<sup>+</sup> and SENSE<sup>-</sup> pins reaches the current limit level (which depends on foldback and the current limit configuration). The corresponding GATE pin is then pulled down and regulated in order to limit the current sense voltage to the current limit value. If this is only happening with one GATE, the other MOSFET is still low impedance and is allowed to carry additional current. When both GATE pins are regulated in current limit, the circuit breaker time delay starts by charging the external timer capacitor from the TIMER pin with a 20μA pull-up current. If the TIMER pin reaches its 1.28V threshold, the external switches turn off with 1mA currents from GATE to ground. If one of the GATE pins stops current limiting before the TIMER pin reaches the 1.28V threshold, the TIMER pin will discharge with 5μA. For a given circuit breaker time

delay,  $t_{CB}$ , the equation for setting the timing capacitor's value is as follows:

$$C_T = t_{CB} \cdot 0.016[\mu\text{F}/\text{ms}]$$

If an overcurrent fault is detected the MOSFET is turned off and the TIMER pin begins discharging with a 5μA pull-down current. When the TIMER pin reaches its 0.15V threshold, it will cycle up and down with 20μA and 5μA 256 times to allow the MOSFETs time to cool down. When automatically retrying, the resulting overcurrent duty cycle is 1:1140. The final time the TIMER pin falls below its 0.15V lower threshold the switches are allowed to turn on again if the overcurrent auto-retry bit is set or the overcurrent fault bit has been reset by the I<sup>2</sup>C interface.

The waveform in Figure 3 shows how the output turns off following a short circuit.

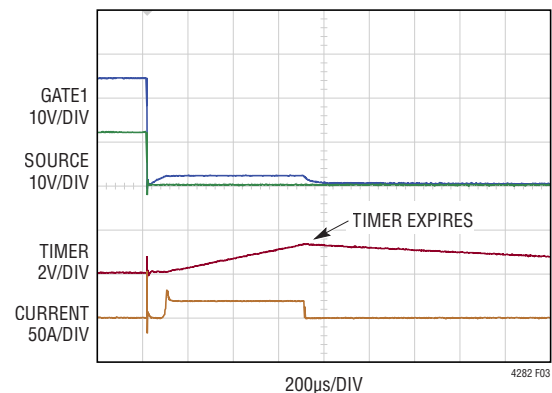

Figure 3. Short-Circuit Waveform

### Advantages of Dual Gate Drivers

The LTC4282 features two gate drivers to improve SOA performance of power MOSFETs in high current applications. Often high current applications feature several MOSFETs in parallel to reach a target  $R_{DS(ON)}$  under 1mΩ that is unavailable in a single MOSFET. In such cases several parallel sense resistors are also used to get small values that are not available as a single resistor. Further, by dividing the load current amongst multiple devices, the PCB current crowding attendant with the use of a single MOSFET is alleviated.

## APPLICATIONS INFORMATION

Parallel MOSFETs share current well when their GATE-to-SOURCE voltages are fully enhanced, however when the MOSFETs are limiting current the offset mismatch between gate thresholds will cause the MOSFET with the lowest threshold to carry more current than the others. As this MOSFET gets hot it carries even more current since threshold voltage has a negative temperature coefficient. Eventually all the load current may be carried by a single MOSFET. For this reason, when a group of MOSFETs are operated in parallel they only provide SOA of a single MOSFET.

The second current limit circuit on the LTC4282 allows a group of parallel MOSFETs to be divided into two banks. During current limiting the independent gate control of the two banks divides the current evenly between them, resulting in twice the SOA performance of a Hot Swap controller with a single current limit circuit. This allows the use of smaller, less expensive MOSFETs, gives it the capability to start up a load twice as big, or makes the design easier with respect to SOA due to increased margins.

The two GATE driver circuits also allow the two banks of MOSFETs to be started up in a staged manner. There are two architectures for doing this, the first is called 'low stress staged start' and the second is called 'high stress staged start'.

Figure 4 shows an example of low stress staged start, where the power-good signal is used to hold GATE2 off until GATE1 has powered up the load. The start-up trickle MOSFET M1 is a compact, inexpensive device with small SOA and is configured for a low current limit with a GATE capacitor to limit inrush current. When the load is fully charged and the start-up MOSFET is fully enhanced, the power-good signal is asserted and the second bypass side is enabled. The second side has a high current limit to deliver the full load current, and uses low  $R_{DS(ON)}$ , low SOA switching regulator class MOSFETs M2 and M3. The TIMER capacitor is selected for a short time within the SOA of the shunt MOSFETs. This architecture minimizes the cost of MOSFETs to achieve a given load current and  $R_{DS(ON)}$ . However, with the brief TIMER time for current limit, it has limited ability to ride through a load surge in current limit, or input voltage steps, and due to the low startup current cannot start up a resistive load such as a heating element or incandescent lamp.

Figure 7 shows an example of high stress staged start. With high stress staged start the second bypass side is gated by the STRESS signal from GPIO2 so that one or more low  $R_{DS(ON)}$ , low SOA MOSFETs can be used to achieve the required  $R_{DS(ON)}$ . The STRESS condition is defined as the  $V_{GS}$  of both MOSFETs being lower than 8V, or the  $V_{DS}$  of M1 being greater than 200mV. The bypass MOSFET(s) are turned off whenever SOA stress is encountered, while a single high SOA stress MOSFET is used for inrush and to ride through transients with a long TIMER time. During inrush the  $V_{DS}$  of the MOSFETs is high and the GATE of the stress MOSFET is not fully enhanced, so the GPIO2 pin is held low to indicate STRESS, which holds the bypass MOSFET(s) off. The stress MOSFET starts up the load alone, either with a GATE capacitor or in current limit. When start-up is complete and the stress MOSFET is fully enhanced ( $V_{DS}$  low and  $V_{GS}$  high), the STRESS condition is removed and the GPIO2 pin goes high to enable the bypass MOSFETs to turn on. This architecture uses the stress MOSFET to ride through current limiting load surges as well as input voltage steps and can also start up a resistive load. The high SOA stress MOSFET is more expensive than the trickle MOSFET in the low stress staged start circuit, but may be cheaper than two or more intermediate SOA MOSFETs used in the parallel configuration (Figure 1).

Figure 9 demonstrates a single MOSFET application. The SENSE2<sup>-</sup> pin is grounded to disable the second current limit circuit and GATE driver so that the part behaves the same as other single Hot Swap controllers like the LTC4280. The GATE2 pin may be left open, or tied to the GATE1 pin to double the GATE pull-down currents for faster turn-off times in response to faults.

### Overvoltage Fault

An overvoltage fault occurs when the OV pin rises above the OV threshold for longer than 25 $\mu$ s. This shuts off the GATE pins with 1mA currents to ground and sets the overvoltage present and overvoltage fault bits (Bit 0) in STATUS and FAULT\_LOG registers 0x1E and 0x04. If the voltage subsequently falls back below the threshold for 50ms, the GATE pins are allowed to turn on again unless overvoltage auto-retry has been disabled by clearing the OV auto-retry bit (Bit 0) in CONTROL register 0x00. If an external resistive divider is used, the OV threshold is

## APPLICATIONS INFORMATION

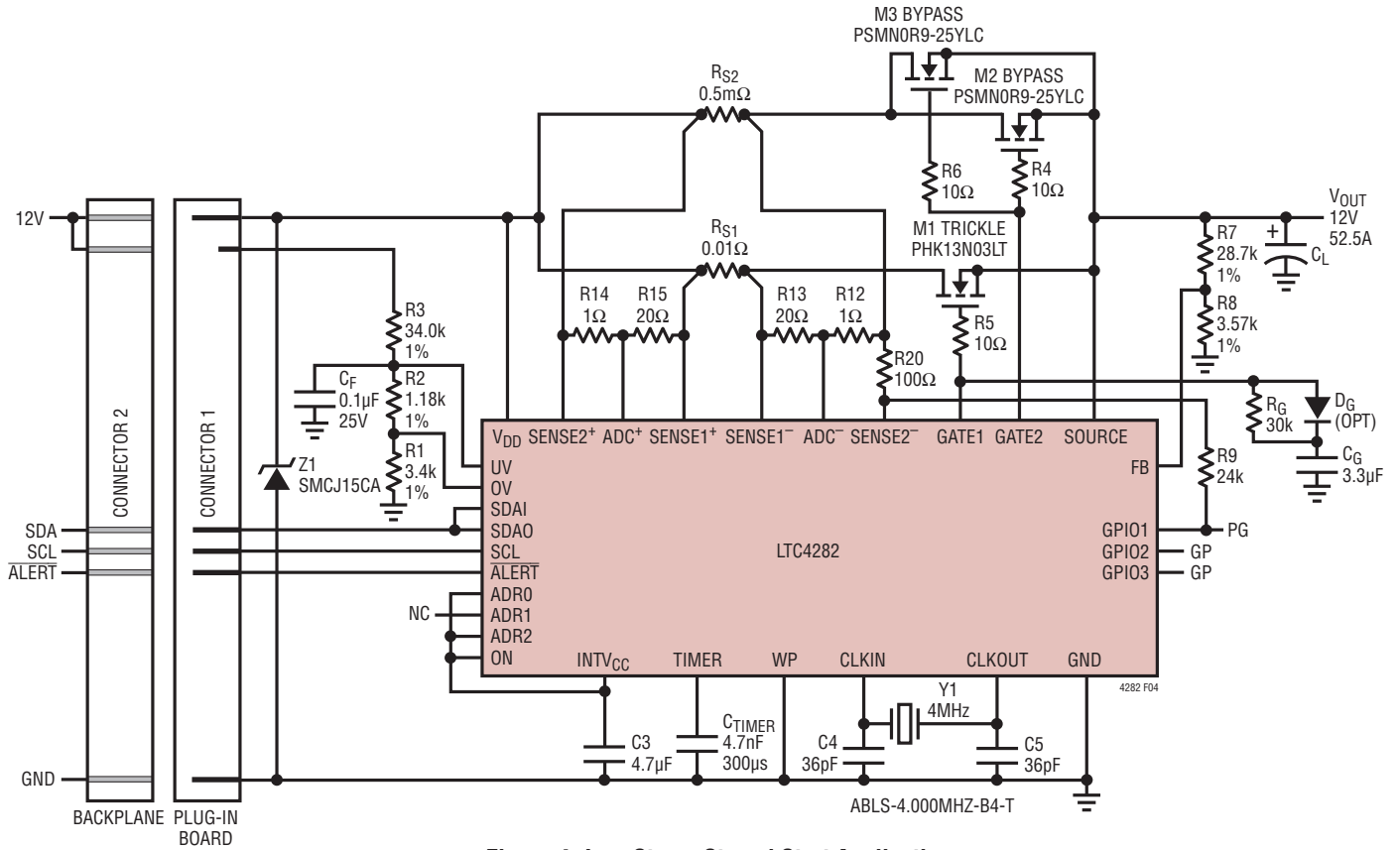

Figure 4. Low Stress Staged Start Application

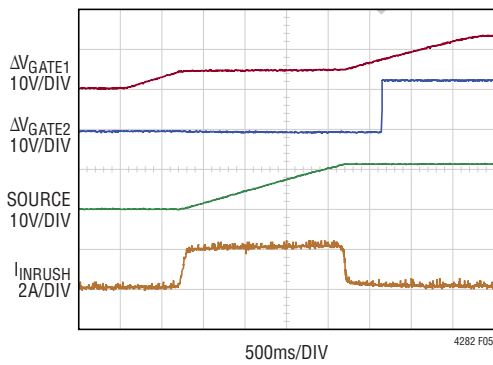

Figure 5. Normal Start-Up with Low Stress Staged Start

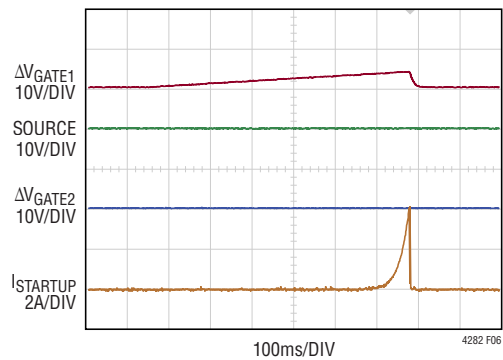

Figure 6. Start-Up Into Short-Circuit with Low Stress Staged Start

APPLICATIONS INFORMATION

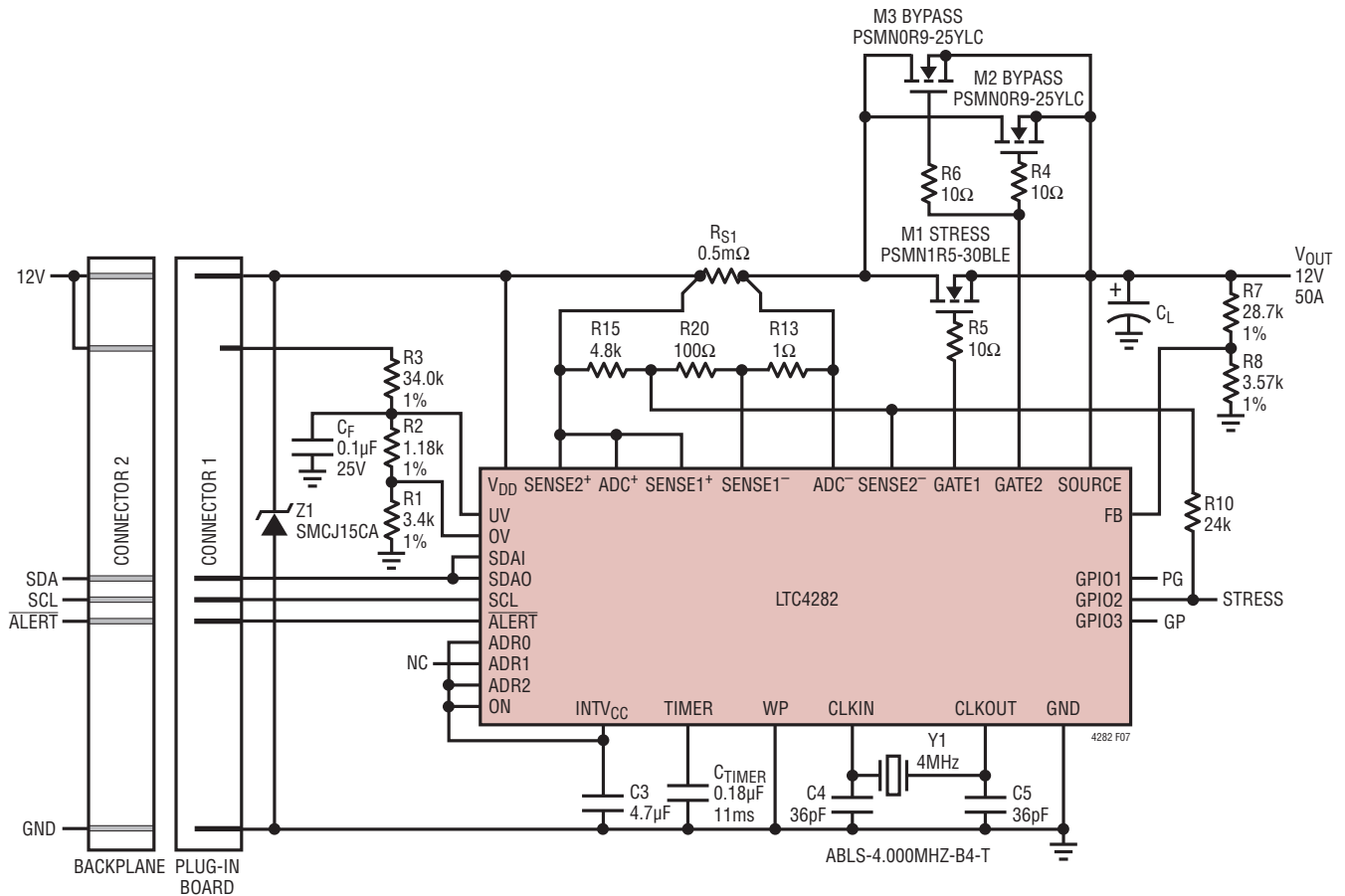

Figure 7. High Stress Staged Start

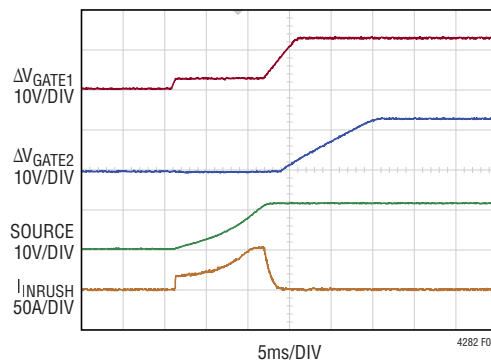

Figure 8. Start-Up Waveform

## APPLICATIONS INFORMATION

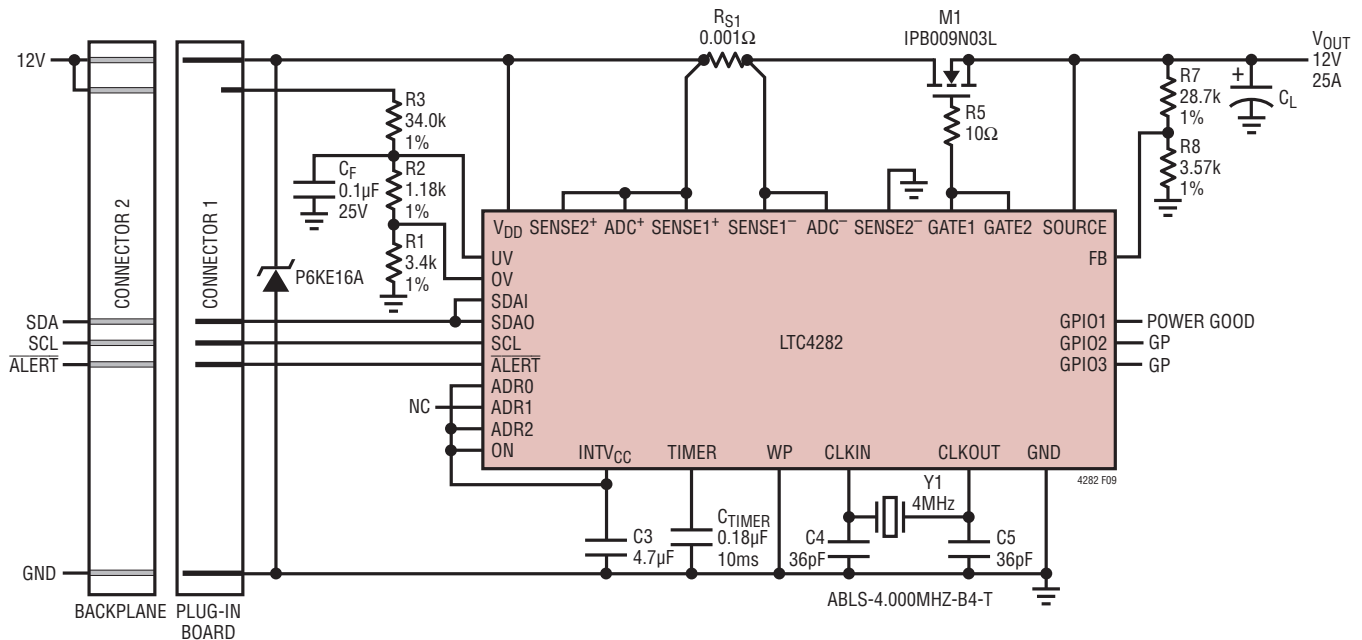

Figure 9. Single MOSFET Configuration

1.28V on the OV pin. When using the internal dividers the OV threshold is referenced to the  $V_{DD}$  pin.

### Undervoltage Fault

An undervoltage fault occurs when the UV pin falls below its 1.28V threshold for longer than 15 $\mu$ s. This shuts off the GATE pins with 1mA currents to ground and sets the undervoltage present and undervoltage fault bits (Bit 1) STATUS and FAULT\_LOG in registers 0x1E and 0x04. If the voltage subsequently rises back above the threshold for 50ms, the GATE pins are allowed to turn on again unless undervoltage auto-retry has been disabled by clearing the UV auto-retry bit in CONTROL register 0x00. For the internal thresholds, the UV and OV signals may be filtered by placing a capacitor on the UV pin.

### ON/OFF Control

The ON pin can be configured active high or active low with CONTROL register 0x00 bit 5 (1 for active high). In the active high configuration it is a true ON input, in the active low configuration it can be used as an  $\overline{\text{ENABLE}}$  input to detect card insertion with a short pin. The delay from the ON pin commanding the part to turn on until the GATE pins begin to rise is set by CONTROL register

0x00 bit 6. If this bit is low the GATE pins turn on immediately, and if it is high they turn on after a 50ms debounce delay. Whenever the ON pin toggles, bit 4 in FAULT\_LOG register 0x04 is set to indicate a change of state and the other bits in FAULT register 0x04 are reset unless the ON\_FAULT\_MASK bit 7 in CONTROL register 0x00 is set.

The FET\_ON bit, bit 3 of CONTROL register 0x00, is set or reset by the rising and falling edges of the ON pin and by I<sup>2</sup>C write commands. When the LTC4282 comes out of UVLO the default state for bit 3 is read out of the EEPROM. If it is a 0, the part is configured to stay off after power-up and ignore the state of the ON pin. If it is a 1 the condition of the ON pin will be latched to bit 3 after the debounce period and the part will turn the GATES on if the ON pin is in the ON state.

If the system shuts down due to a fault, it may be desirable to restart the system simply by removing and reinserting a load card. In cases where the LTC4282 and the switch reside on a backplane or midplane and the load resides on a plug-in card, the ON pin detects when the plug-in card is removed. Figure 10 shows an example where the ON pin is used to detect insertion. Once the plug-in card is reinserted the FAULT\_LOG register 0x04 is cleared (except for bit 4, which indicates the ON pin

## APPLICATIONS INFORMATION

changed state). After the ON pin turn-on delay, the system is allowed to start up again.

If a connection sense on the plug-in card is driving the ON pin, insertion or removal of the card may cause the pin voltage to bounce. This results in clearing the FAULT\_LOG register when the card is removed. The pin may be debounced using a filter capacitor,  $C_{ON}$ , on the ON pin as shown in Figure 10. Note that the polarity of the ON pin is inverted with CONTROL register 0x00 bit 5 set to 0.

### FET Bad Fault

In a Hot Swap application several possible faults can prevent the MOSFETs from turning on and reaching a low impedance state. A damaged MOSFET may have leakage from gate to drain or have degraded  $R_{DS(ON)}$ . Debris on the board may also produce leakage or a short from the GATE pin to the SOURCE pin, the MOSFET drain, or to ground. In these conditions the LTC4282 may not be able to pull the GATE pin high enough to fully enhance the MOSFET, or the MOSFET may not reach the intended  $R_{DS(ON)}$  when the GATE pin is fully enhanced. This can put the MOSFET in a condition where the power in the MOSFET is higher than its continuous power capability, even though the current is below the current limit. The LTC4282 monitors the integrity of the MOSFETs in two ways, and acts on both of them in the same manner.

First, the LTC4282 monitors the voltage between the  $V_{DD}$  and SOURCE pins. A comparator detects a bad DRAIN-to-SOURCE voltage ( $V_{DS}$ ) whenever the  $V_{DS}$  is greater than 200mV.

Second, the LTC4282 monitors the GATE voltage. The GATE voltage may not fully enhance with a damaged MOSFET, and a severely damaged MOSFET most often has GATE, DRAIN and SOURCE all shorted together. If the LTC4282 is in the ON state, but neither GATE pin comes up to their 8V threshold above SOURCE, a FET-bad condition is detected.

When either FET-bad condition is present while the MOSFETs are commanded on, an internal FET-bad fault timer starts. When the timer reaches the threshold set in register 0x06 (1ms per LSB for a max of 255ms), a FET-bad fault condition is set, the part turns off, and the GATE

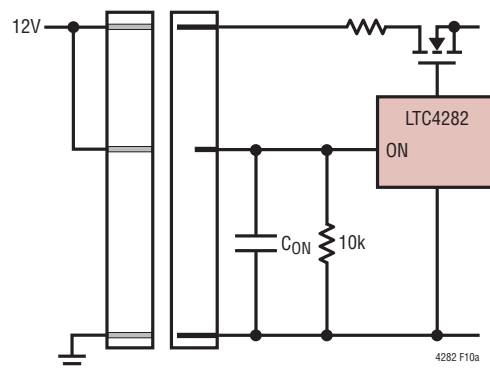

(a) ON Configured Active High (Default)  
CONTROL Register 0x00 Bit 5=1

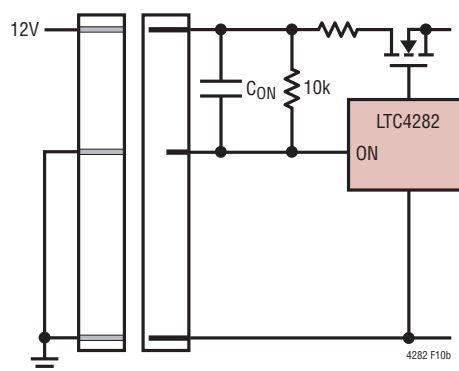

(b) ON Configured Active Low CONTROL  
Register 0x00 Bit 5=0

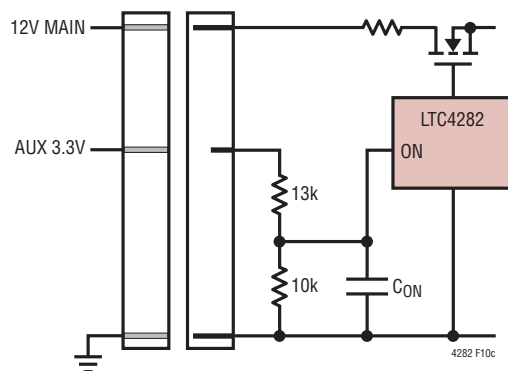

(c) ON Pin Sensing of AUX Supply ON  
Pin Configured Active High (Default)

Figure 10. Connection Sense Configurations with the ON Pin

## APPLICATIONS INFORMATION

pins are pulled low with 1mA currents. In the case of a gate-to-drain short, it may be impossible for the LTC4282 to turn off the MOSFET. In this case the LTC4282 can be configured to signal power-bad to the load so the load goes into a low current state and send a FET-bad fault alert to the controller that may be able to shut down upstream supplies and/or flag the card for service.

The LTC4282 treats a FET-bad fault similar to an overcurrent fault, and will auto-retry after 256 timer cycles if the overcurrent auto-retry bit is set. Note that during start-up, the FET-bad condition is present because the voltage from drain to source is greater than 200mV and the GATE pins are not fully enhanced, thus the FET-bad timeout must be long enough to allow for the largest allowable load to start up. FET-bad faults are disabled by setting the FET\_BAD\_FAULT\_TIMER value to 0x00.

### FET Short Fault

A FET short fault is reported if the data converter measures a current sense voltage greater than or equal to 0.25mV while the GATE pins are turned off. This condition sets FET\_SHORT bit 5 in STATUS register 0x1E, and FET\_SHORT\_FAULT bit 5 in FAULT\_LOG register 0x04.

### Power Bad Fault

The POWER\_GOOD status bit, bit 3 in STATUS register 0x1E, is set when the FB pin voltage rises above its 1.28V threshold. To indicate POWER\_GOOD on the GPIO1 pin, one or both GATE pins must first exceed their 8V  $V_{GS}$  thresholds after start-up; this requirement prevents POWER\_GOOD from asserting during start-up when the FB pin first crosses its threshold. After start-up the GPIO1 pin will output the value of the FB comparator so that

POWER\_GOOD stays high even in cases such as an input voltage step that causes the GATE pins to briefly dip below 8V  $V_{GS}$ . See Figure 11.

A power-bad fault is generated when the FB pin is low and one or both GATE pins are high, preventing power-bad faults when both GATE-to-SOURCE voltages are low during power-up or power-down.

### Fault Alerts

A fault condition sets the corresponding fault bit in FAULT\_LOG register 0x04, ADC\_ALERT\_LOG register 0x05, and TICKER\_OVERFLOW\_PRESENT (Bit 0) and METER\_OVERFLOW\_PRESENT (Bit 1) in the STATUS register 0x1F. Fault bits are reset by writing a 0 and the overflow status bits are reset by resetting the energy meter by setting and resetting ADC\_CONTROL register 0x1D bit 6. A fault condition can also generate an alert ( $\overline{\text{ALERT}}$  asserts low) by setting the corresponding bit in the alert mask registers: ALERT registers 0x02 and 0x03, and GPIO\_CONFIG register bit 0. A low on  $\overline{\text{ALERT}}$  may be generated upon completion of an ADC measurement by setting bit 2 in the GPIO\_CONFIG register 0x07. This condition does not have a corresponding fault bit. Faults with enabled alerts set bit 7 in the ALERT\_CONTROL register 0x1C, which controls the state of the  $\overline{\text{ALERT}}$  pin. Clearing this bit will cause the  $\overline{\text{ALERT}}$  pin to go high and setting this bit causes it to go low. Alert masking stored in EEPROM is transferred into registers at power up.

After the bus master controller broadcasts the Alert Response Address, the LTC4282 responds with its address on the SDA line and releases  $\overline{\text{ALERT}}$  as shown in Figure 20. If there is a collision between two LTC4282s responding with their addresses simultaneously, then

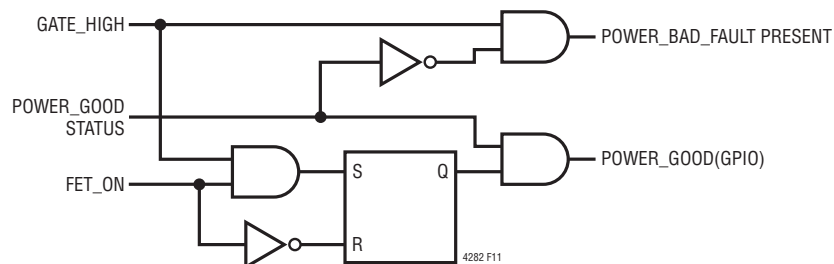

Figure 11. POWER\_GOOD Logic

## APPLICATIONS INFORMATION

the device with the lower address wins arbitration and releases its  $\overline{\text{ALERT}}$  pin. The devices that lost arbitration will still hold the  $\overline{\text{ALERT}}$  pin low and will respond with their addresses and release  $\overline{\text{ALERT}}$  as the I<sup>2</sup>C master executes additional Alert Response protocols until  $\overline{\text{ALERT}}$  is released by all devices. The  $\overline{\text{ALERT}}$  pin can also be released by clearing ALERT\_CONTROL bit 7 in register 0x1C with the I<sup>2</sup>C interface.

The  $\overline{\text{ALERT}}$  pin can also be used as a GPIO pin, which pulls low by setting ALERT bit 6 in register 0x1C, and the  $\overline{\text{ALERT}}$  pin input status is stored in STATUS register 0x1F bit 4.

Once the  $\overline{\text{ALERT}}$  signal has been released from a fault, it will pull low again if the corresponding fault reoccurs, but not if the fault remains continuously present.

### Resetting Faults in FAULT\_LOG

The faults in FAULT\_LOG register 0x04 may cause the part to latch off if their corresponding auto-retry bits are not set. In backplane resident applications it is desirable to latch off if a card has produced a failure and start up normally if the card is replaced. To allow this function the ON pin must be used as a connection sense input. When CONTROL bit 7 in register 0x00 is not set, a turn-off signal from the ON pin (card removed) will clear the FAULT\_LOG register except for bit 4 (ON changed state). The entire FAULT\_LOG register is also cleared when the INTV<sub>CC</sub> pin falls below its 2.49V threshold (UVLO), and individual bits may be cleared manually via that I<sup>2</sup>C interface. Note that faults that are still present, as indicated in STATUS register 0x1E, cannot be cleared.

When the ON\_FAULT\_MASK bit (CONTROL bit 7 in register 0x00) is set, a turn-off signal from the ON pin will not clear the FAULT\_LOG register. Additionally, when the corresponding ON\_FAULT\_MASK bit is set in the EEPROM, the FAULT\_LOG register 0x04 is loaded from the EEPROM (0x24) at boot. In this case, stored faults in the EEPROM are loaded into the FAULT\_LOG register. This may be used in conjunction with disabling fault auto-retry to configure a card to not attempt to turn on again after a fault has been logged, even after a power cycle, until the system controller has interrogated the card and cleared the fault or flagged the card for service. For applications where the system controller is downstream of the hot

swap, all auto-retries should be enabled when the ON\_FAULT\_MASK bit in the EEPROM is set and fault logging is enabled so that logged faults do not permanently latch the hot swap off.

The FAULT\_LOG register is not cleared when auto-retrying. When auto-retry is disabled the existence of a logged fault keeps the MOSFETs off. As soon as the FAULT\_LOG is cleared, the MOSFETs turn on. If auto-retry is enabled, then a high STATUS bit keeps the MOSFETs off and the FAULT\_LOG bit is ignored. Subsequently, when the status bit is cleared by removal of the fault condition, the MOSFETs are allowed to turn on again even though the fault bit remains set as a record of the previous fault conditions.

### Reboot

The LTC4282 features a reboot command bit, located in bit 7 of ADC\_CONTROL register 0x1D. Setting this bit will cause the LTC4282 to reset and copy the contents of the EEPROM to operating memory the same as after initial power up. The 50ms debounce before the part restarts is lengthened to 3.2s for reboot in order to allow load capacitance to discharge and reset before the LTC4282 turns back on. On systems where the Hot Swap controller supplies power to the I<sup>2</sup>C master, this allows the master to issue a command that power cycles the entire board, including itself.

### Data Converters

The LTC4282 incorporates a pair of sigma delta A/D converters that are configurable to 12 or 16 bits. One converter continuously samples the current sense voltage, while the other monitors the input/output voltage and the voltage on a GPIO input. The sigma-delta architecture inherently averages signal noise during the measurement period.

The data converters may be run in a 12-bit or 16-bit mode, as selected by bit 0 in ILIM\_ADJUST register 0x11. The second data converter may be configured to measure V<sub>IN</sub> at the V<sub>DD</sub> pin or V<sub>OUT</sub> at the SOURCE pin by setting bit 2, and can select between measuring GPIO2 or GPIO3 with bit 1. The data converter full scale is 40mV for the current sense voltage, a choice of 33.28V, 16.64V, 8.32V or 5.547V for V<sub>DD</sub> and V<sub>SOURCE</sub>, and 1.28V for GPIO.

## APPLICATIONS INFORMATION

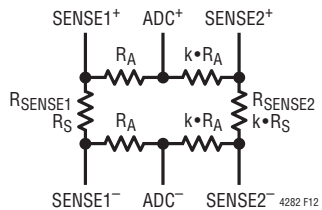

Figure 12. Weighted Averaging Sense Voltages

The ADC<sup>+</sup> and ADC<sup>-</sup> input pins allow the ADC to measure the average voltage across the two sense resistors using resistive dividers. Some applications may use parallel sense resistors to achieve a specific resistance, in which case the averaging resistors can be selected with the same ratio as the sense resistors they connect to, which allows the ADC to still measure current accurately. See Figure 12. In this case the effective ADC sense resistor is  $R_S$  in parallel with  $k \cdot R_S$  for the current limit. Scaling the averaging resistors,  $R_A$ , by the same scaling factor,  $k$ , allows the ADC to measure the correct sense voltage for this effective sense resistor. The smallest averaging resistor should not exceed  $1\Omega$ .

The two data converters are synchronized, and after each current measurement conversion, the measured current is multiplied by the measured  $V_{DD}$  or  $V_{SOURCE}$  to yield input or output power. After each conversion the measurement results and power are compared to the recorded min and max values. If the measurement is a new min or max, then those registers are updated. The measurements are also compared to the min/max alarm thresholds in registers 0x08 to 0x0F and will set the corresponding ADC alert bit in ADC\_ALERT\_LOG register 0x05 and generate an alert if configured to do so in ALERT register 0x03.

After each measurement, calculated power is added to an accumulator that meters energy. Since the current is continuously monitored by a dedicated ADC, the current is sampled every  $16\mu s$ , ensuring that the energy meter will accurately meter noisy loads up to 62.5kHz noise frequency. The 6-byte energy meter is capable of accumulating 20 days of power at full scale, which is several months at a nominal power level. An optional alert may be generated when the meter overflows. To measure coulombs, the energy meter may be configured to accumulate current rather than power by setting CLK\_DIVIDER register 0x10 bit 7.

A time counter keeps track of how many times power has been added into the energy meter. Dividing the energy by the number in the counter will yield the average power over the accumulation interval. When metering coulombs dividing the metered charge by the counter produces the average current over the accumulation interval. The 4 byte time counter will keep count for 10 years in the 12-bit mode before overflowing, and can generate an alert at full scale to indicate that the counter is about to roll over. Multiplying the value in the counter by  $t_{CONV}$  yields the time that the energy meter has been accumulating.

Both the energy accumulator and time counter are writable, allowing them to be pre-loaded with a given energy and/or time before overflow so that the LTC4282 will generate an overflow alert after either a specified amount of energy has been delivered or time has passed.

The following formulas are used to convert the values in the ADC result registers into physical units. The data in the 12-bit mode is left justified, so the same equations apply to the 12-bit mode and the 16-bit mode.

To calculate GPIO voltage:

$$V = \frac{\text{CODE(word)} \cdot 1.280}{2^{16} - 1}$$

To calculate input/output voltage:

$$V = \frac{\text{CODE(word)} \cdot V_{FS(OUT)}}{2^{16} - 1}$$

where  $V_{FS(OUT)}$  is 33.28V, 16.64V, 8.32V or 5.547V depending on the part being in 24V, 12V, 5V or 3.3V mode, respectively.

To calculate current in amperes:

$$I = \frac{\text{CODE(word)} \cdot 0.040V}{(2^{16} - 1) \cdot R_{SENSE}}$$

To calculate power in watts:

$$P = \frac{\text{CODE(word)} \cdot 0.040V \cdot V_{FS(OUT)} \cdot 2^{16}}{(2^{16} - 1)^2 \cdot R_{SENSE}}$$

## APPLICATIONS INFORMATION

To calculate energy in joules:

$$E = \frac{\text{CODE}(48 \text{ bits}) \cdot 0.040\text{V} \cdot V_{\text{FS(OUT)}} \cdot t_{\text{CONV}} \cdot 2^8}{(2^{16} - 1)^2 \cdot R_{\text{SENSE}}}$$

To calculate coulombs:

$$C = \frac{\text{CODE}(48 \text{ Bits}) \cdot 0.040\text{V} \cdot t_{\text{CONV}}}{(2^{16} - 1) \cdot R_{\text{SENSE}}}$$

where  $t_{\text{CONV}} = (1/f_{\text{CONV}})$  is 0.065535s for 12-bit mode and 1.0486s for 16-bit mode.

To calculate average power over the energy accumulation period:

$$P(\text{AVG}) = \frac{E}{t_{\text{CONV}} \cdot \text{CODE}(\text{COUNTER})}$$

To calculate Average current:

$$I(\text{AVG}) = \frac{C}{t_{\text{CONV}} \cdot \text{CODE}(\text{COUNTER})}$$

To calculate GPIO voltage Alarm thresholds:

$$V = \frac{\text{CODE}(\text{byte}) \cdot 1.280}{255}$$

To calculate input/output voltage Alarm thresholds:

$$V_{\text{ALARM}} = \frac{\text{CODE}(\text{byte}) \cdot V_{\text{FS(OUT)}}}{255}$$

where  $V_{\text{FS(OUT)}}$  is 33.28V, 16.64V, 8.32V or 5.547V depending on the part being in 24V, 12V, 5V or 3.3V mode, respectively.

To calculate current Alarm thresholds in amps:

$$I = \frac{\text{CODE}(\text{byte}) \cdot 0.040\text{V}}{255 \cdot R_{\text{SENSE}}}$$

To calculate power Alarm threshold in watts:

$$P = \frac{\text{CODE}(\text{byte}) \cdot 0.040\text{V} \cdot V_{\text{FS(OUT)}} \cdot 2^8}{R_{\text{SENSE}} \cdot 255 \cdot 255}$$

Note that falling Alarm thresholds use  $\text{CODE}(\text{byte})+1$  in the above equations since they trip at the top edge of the code, which is 1LSB higher than the rising threshold.

### CLKIN, CLKOUT: Crystal Oscillator/External Clock

Accurately measuring energy by integrating power requires a precise integration period. The on-chip clock of the LTC4282 is trimmed to 1.5% and specified ( $f_{\text{CONV}}$ ) over temperature to 5% and is invoked by grounding CLKIN. For increased accuracy a crystal oscillator or external precision clock may be used on the CLKIN and CLKOUT pins. A 4MHz crystal oscillator or resonator may be connected to the two CLK pins as shown in Figure 1.

Crystal oscillators are sensitive to noise and parasitic capacitance. Care should be taken in layout to minimize trace length between the LTC4282 and the crystal. Keep noisy traces away from the crystal traces, or shield the crystal traces with a ground trace.

Alternatively, an external clock may be applied to CLKIN with CLKOUT left unconnected. The LTC4282 can accept an external clock between 250kHz and 15.5MHz, with clocks faster than 250kHz reduced to 250kHz by a programmable divider, the clock frequency is divided by twice the value in register 0x10 bits 0-4. Code 00000 passes the clock through CLK\_DIVIDER without division. Write code 01000 divides a 4MHz clock down to 250kHz. The divided external clock may differ from 250kHz by 5% without affecting other specifications.

### Configuring the GPIO Pins

The LTC4282 has three GPIO pins and an  $\overline{\text{ALERT}}$  pin, all of which can be used as general purpose input/output pins. The GPIO1 pin is configured using the GPIO\_CONFIG register 0x07 bits 5-4. GPIO2 will pull low to indicate MOSFET stress if GPIO\_CONFIG bit 1 is set and pulls low if bit 6 is low. GPIO3 pulls low if GPIO\_CONFIG bit 7 is set and is otherwise high impedance. The  $\overline{\text{ALERT}}$  pin can be used as a GPIO pin by setting all the alert enable bits to 0 to disable alerts, then setting bit 6 in ALERT\_CONTROL register 0x1C. Bit 7 in ALERT\_CONTROL can also be set to pull the  $\overline{\text{ALERT}}$  pin low, but bit 7 will cause the part to respond to the alert response protocol, while bit 6 will not.

## APPLICATIONS INFORMATION

GPIO1-GPIO3 and  $\overline{\text{ALERT}}$  all have comparators monitoring the voltage on these pins with a threshold of 1.28V even when the pins are configured as outputs. The results may be read from the second byte of the STATUS register, 0x1F, bits 4-7.

### Supply Transients

In card-resident applications, output short circuits working against the inductive nature of the supply can easily cause the input voltage to dip below the UV threshold.

In severe cases where the supply inductance is 500nH or more, the input can dip below the  $V_{DD}$  undervoltage lockout threshold of 2.66V. Because the current passing through the sense resistor changes no faster than a rate of  $V_{\text{SUPPLY}}/L_{\text{SUPPLY}}$ , such as  $12\text{V}/500\text{nH} = 24\text{A}/\mu\text{s}$ , it is possible for the UV comparator and in particular, the  $V_{DD}$  UVLO circuit to respond before the current reaches the current limit threshold. The  $V_{DD}$  UVLO circuit responds after a 2 $\mu\text{s}$  filter delay, pulling the GATE pins to SOURCE with 600mA. Once the MOSFET turns off,  $V_{DD}$  will return to its nominal voltage and the part initiates a new startup sequence. The UV comparator responds after a 15 $\mu\text{s}$  filter delay, making it less likely that this path will engage before current limiting commences; adding a 100nF filter capacitor to the UV pin ensures this. The fast current limit amplifier engages at 3x the current limit threshold, and has a propagation delay of 500ns. If the supply inductance is less than 500nH in a 12V application, it is unlikely that the  $V_{DD}$  UVLO threshold will be breached and the fast di/dt rate allows the current to rise to the 3x level long before the UV pin responds.

Once the fast current limit amplifier begins to arrest the short circuit current, the input voltage rapidly recovers and even overshoots its DC value. The LTC4282 is safe from damage up to 45V. To minimize spikes in backplane-resident applications, bypass the LTC4282 input supply with an electrolytic capacitor between  $V_{DD}$  and GND. In card-resident applications clamp the  $V_{DD}$  pin with a surge suppressor Z1, as shown in Figure 1.

The worst-case Z1 current is that which triggers the fast current limit circuit. Several 1500W surge suppressors may be required to clamp this current for high power applications. Many 20V to 30V MOSFETs enter avalanche breakdown before 45V. In those cases the MOSFET can act as a surge suppressor and protect the Hot Swap

controller from inductive input voltage surges. In applications where a high current ground is not available to connect the surge suppressor, the surge suppressor may be connected from input to output, allowing the output capacitance to absorb spikes.

### Design Example

As a design example, consider the following specifications:  $V_{IN} = 12\text{V}$ ,  $I_{MAX} = 100\text{A}$ ,  $C_L = 3300\mu\text{F}$ ,  $V_{UV(\text{RISING})} = 10.75\text{V}$ ,  $V_{OV(\text{FALLING})} = 14.0\text{V}$ ,  $V_{PWRGD(\text{UP})} = 11.6\text{V}$ , and I<sup>2</sup>C address = 1010011, using two parallel MOSFETs with current limit set at 25mV. This completed design is shown in Figure 13.

Selection of the sense resistors,  $R_{S1}/R_{S2}$ , is set by the current limit threshold of 25mV:

$$R_S = \frac{25\text{mV} \cdot 2\text{Resistors}}{I_{MAX}} = 0.5\text{m}\Omega$$

Each sensor resistor may need to be divided into several parallel sense resistors in order to keep the power dissipation within limits. Often the temperature coefficient of current sense resistors is poor for very low values, in which cases accuracy is improved by using several larger value resistors in parallel instead of a single low value resistor. The same resistor averaging method used for the ADC pins in Figure 12 may be used with the SENSE pins to accurately sense the current in parallel resistors.

The MOSFETs are sized to handle the power dissipation during inrush when output capacitor  $C_{OUT}$  is being charged.

A method to determine power dissipation during inrush is based on the principle that:

$$\text{Energy in } C_L = \text{Energy in Q1 and Q2}$$

where:

$$\text{Energy in } C_L = \frac{1}{2}CV^2 = \frac{1}{2}(3.3\text{mF})(12\text{V})^2 = 0.24\text{J}$$

During inrush, current limit foldback will limit the power dissipation in each MOSFET to:

$$P_{DISS} = \frac{7.5\text{mV} \cdot 12\text{V}}{R_S} = 180\text{W}$$

## APPLICATIONS INFORMATION

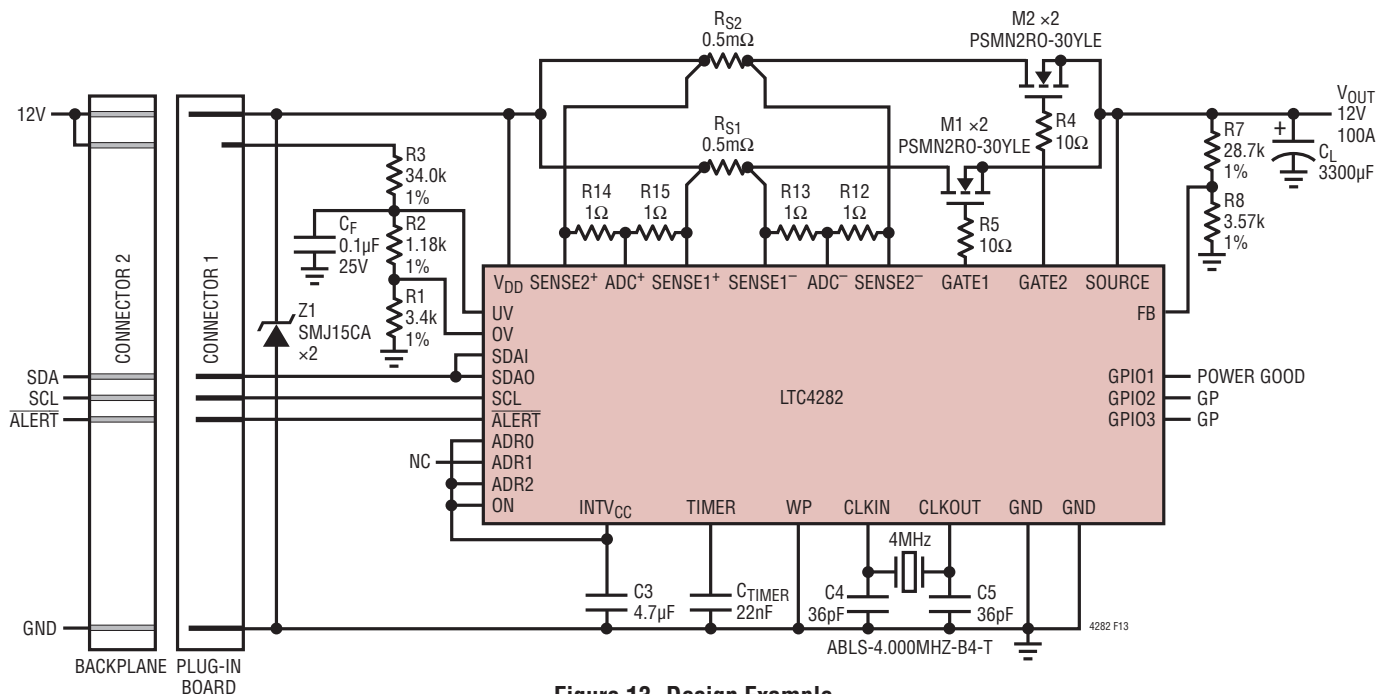

Figure 13. Design Example

Calculate the time it takes to charge  $C_{OUT}$ :

$$t_{STARTUP} = \frac{\text{Energy in } C_L}{P_{DISS} \cdot 2 \text{ MOSFETS}} = \frac{0.24\text{J}}{180\text{W} \cdot 2} = 0.66\text{ms}$$

The SOA (safe operating area) curves of candidate MOSFETs must be evaluated to ensure that the heat capacity of the package tolerates 180W for 0.66ms. The SOA curve of the NXP PSMN2R0-30YLE shows 200W for 80ms, satisfying this requirement. Additional MOSFETs in parallel may be required to keep the MOSFET temperature or power dissipation within limits at maximum load current. This depends on board layout, airflow and efficiency requirements. To get the maximum DC dissipation below 2W per MOSFET, a pair of PSMN2R0-30YLE is required for both M1 and M2, for a total of 4 MOSFETs. Since the PSMN2R0-30YLE has 10nF of gate capacitance it is likely to be stable, but the short-circuit stability of the current limit loop should be checked and improved by adding capacitors from GATE to SOURCE if needed.

For a start-up time of 0.66ms with a 2x safety margin we choose:

$$C_{TIMER} = 2 \cdot \frac{t_{STARTUP}}{64\text{ms}/\mu\text{F}} = 2 \cdot \frac{0.66\text{ms}}{64\text{ms}/\mu\text{F}} \approx 22\text{nF}$$

In the event that the circuit attempts to start up into a short circuit the current will be 30% of 100A, 30A, and the voltage across the MOSFET will be 12V. Each MOSFET will carry half of the current so they need SOA for 15A and 12V for 1.33ms. This is within the SOA of the PSMN2R0-30YLE, so the application will safely survive this fault condition.

The UV and OV resistor string values can be solved in the following method. To keep the error due to 1μA of leakage to less than 1% choose a divider current of at least 200μA.  $R1 < 1.28\text{V}/200\mu\text{A} = 6.4\text{k}\Omega$ . Then calculate the following equations:

$$R2 = \frac{V_{OV(\text{FALLING})}}{V_{UV(\text{RISING})}} \cdot R1 \cdot \frac{V_{TH(UV)}}{V_{TH(OV)} - V_{HYST(OV)}} - R1$$

$$R3 = \frac{V_{UV(\text{RISING})} \cdot (R1 + R2)}{V_{TH(UV)}} - R1 - R2$$

In our case we choose R1 to be 3.4kΩ to give a resistor string current greater than 200μA. Then solving the equations results in R2 = 1.18kΩ and R3 = 34.0kΩ.

## APPLICATIONS INFORMATION

The FB divider is solved by picking R8 and solving for R7, choosing 3.57kΩ for R8 we get:

$$R7 = \frac{V_{PWRGD(UP)} \cdot R8}{V_{TH(FB)}} - R8$$

resulting in  $R7 = 28.7k\Omega$ .

Since this application uses external resistive dividers for UV, OV and FB, and the operating voltage is 12V, the CONTROL register 0x01 is set to 0x02 to disable the internal thresholds and set the ADC to the 12V range. The EEPROM CONTROL register 0x21 is also set to 0x02 so the part will boot in the proper configuration.

Since the start-up time is 0.66ms, the FET\_BAD FAULT TIME is set to 2ms for a  $\geq 2x$  safety margin by writing 0x02 to the FET\_BAD\_FAULT\_TIME register 0x06.

A 0.1μF capacitor,  $C_F$ , is placed on the UV pin to prevent supply glitches from turning off the GATE via UV or OV.

The address is set with the help of Table 1, which indicates binary address 1010011 (0xA6). Address 0xA6 is set by setting ADR2 high, ADR1 open and ADR0 high.

Next the value of R4 and R5 are chosen to be the default value of 10Ω as discussed in the Current Limit Stability section.

R12-R15 average the two current sense voltages for the ADC. Since the ADC<sup>+</sup> pin may draw up to 50μA, parallel 1Ω resistors R14 and R15 will cause a max ADC offset of 25μV.

A 4MHz crystal is placed between the CLKIN and CLKOUT pins. The specified part requires 18pF of load capacitance, which is provided by C4 and C5. To generate an internal clock of 250kHz, 1000b is written to the CLOCK\_DIVIDER register 0x10 to divide the 4MHz crystal frequency by 16.

Since the fast pull-down is engaged at 300A, the input TVS needs to be capable of clamping a 300A surge at a voltage above the OV threshold but below the 45V absolute maximum rating of the LTC4282 for about 1μs. The SMCJ15CA clamps 61.5A at 24V for 8.3ms, and can dissipate 30kW for 1μs. A pair of them will meet these requirements.

In addition a 4.7μF ceramic bypass capacitor is placed on the INTV<sub>CC</sub> pin. No bypass capacitor is required on the V<sub>DD</sub> pin.

### Layout Considerations

To achieve accurate current sensing, Kelvin connections are required. The minimum trace width for 1oz copper foil is 0.02" per amp to make sure the trace stays at a reasonable temperature. Using 0.03" per amp or wider is recommended. Note that 1oz copper exhibits a sheet resistance of about 530μΩ/□. Small resistances add up quickly in high current applications.

To improve noise immunity, put the resistive dividers to the UV, OV and FB pins close to the device and keep traces to V<sub>DD</sub> and GND short. It is also important to put the bypass capacitor C3 as close as possible between INTV<sub>CC</sub> and GND. A 0.1μF capacitor,  $C_F$ , from the UV pin (and OV pin through resistor R2) to GND also helps reject supply noise. Figure 14 shows a layout that addresses these issues. Note that a surge suppressor, Z1, is placed between supply and ground using wide traces.

It is ill advised to place the ground plane under the power MOSFETs. If they fail and overheat that could result in a catastrophic failure as the input gets shorted to ground when the insulation between them fails.

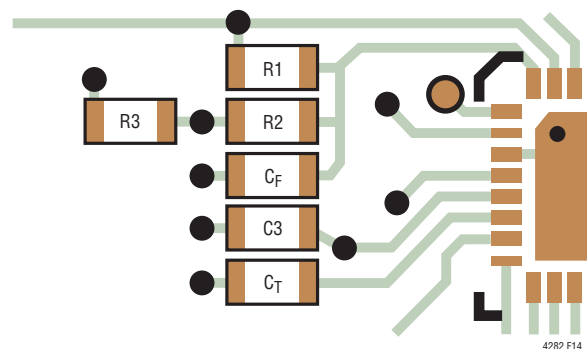

Figure 14. Recommended Layout

## APPLICATIONS INFORMATION

### Digital Interface

The LTC4282 communicates with a bus master using a 2-wire interface compatible with I<sup>2</sup>C Bus and SMBus, an I<sup>2</sup>C extension for low power devices. The LTC4282 is a read-write slave device and supports SMBus bus Read Byte, Write Byte, Read Word and Write Word commands, as well as I<sup>2</sup>C continuous read and continuous write commands. Data formats for these commands are shown in Figure 15 through Figure 22.

### START and STOP Conditions

When the bus is idle, both SCL and SDA are high. A bus master signals the beginning of a transmission with a START condition by transitioning SDA from high to low while SCL is high, as shown in Figure 15. When the master has finished communicating with the slave, it issues a STOP condition by transitioning SDA from low to high while SCL is high. The bus is then free for another transmission.

### I<sup>2</sup>C Device Addressing

Twenty-seven distinct bus addresses are available using three 3-state address pins, ADR0-ADR2. Table 1 shows the correspondence between pin states and addresses. Note that address bits 7 and 6 are internally configured to 10. In addition, the LTC4282 responds to two special addresses. Address 0xBE is a mass write address that writes to all LTC4282s, regardless of their individual address settings. Mass write can be disabled by setting bit 4 in CONTROL register 0x00 to zero. Address (0x19) is the SMBus Alert Response Address. If the LTC4282 is pulling low on the  $\overline{\text{ALERT}}$  pin, it acknowledges this address by broadcasting its address and releasing the  $\overline{\text{ALERT}}$  pin.

### Acknowledge

The acknowledge signal is used in handshaking between transmitter and receiver to indicate that the last byte of data was received. The transmitter always releases the SDA line during the acknowledge clock pulse. When the slave is the receiver, it pulls down the SDA line so that it remains LOW during this pulse to acknowledge receipt

of the data. If the slave fails to acknowledge by leaving SDA high, then the master may abort the transmission by generating a STOP condition. When the master is receiving data from the slave, the master pulls down the SDA line during the clock pulse to indicate receipt of the data. After the last byte has been received the master leaves the SDA line HIGH (not acknowledge) and issues a stop condition to terminate the transmission.

### Write Protocol

The master begins communication with a START condition followed by the seven bit slave address and the R/W bit set to zero, as shown in Figure 16. The addressed LTC4282 acknowledges this and then the master sends a command byte indicating which internal register the master wishes to write. The LTC4282 acknowledges this and then latches the command byte into its internal Register Address pointer. The master then delivers the data byte and the LTC4282 acknowledges once more and writes the data to the destination register specified by the Register Address pointer, then the pointer is incremented. If the Master sends additional bytes, they are written sequentially to the registers in order of their binary addresses. The transmission is ended when the master sends a STOP condition.

### Read Protocol

The master begins a read operation with a START condition followed by the seven bit slave address and the R/W bit set to zero, as shown in Figure 19. The addressed LTC4282 acknowledges this and then the master sends a command byte which indicates which internal register the master wishes to read. The LTC4282 acknowledges this and then latches the command byte into its internal Register Address pointer. The master then sends a repeated START condition followed by the same seven bit address with the R/W bit now set to one. The LTC4282 acknowledges and send the contents of the requested register. As long as the master acknowledges the transmitted data byte the internal Register Address pointer is incremented and the next register byte is sent. The transmission is ended when the master sends a STOP condition.

APPLICATIONS INFORMATION

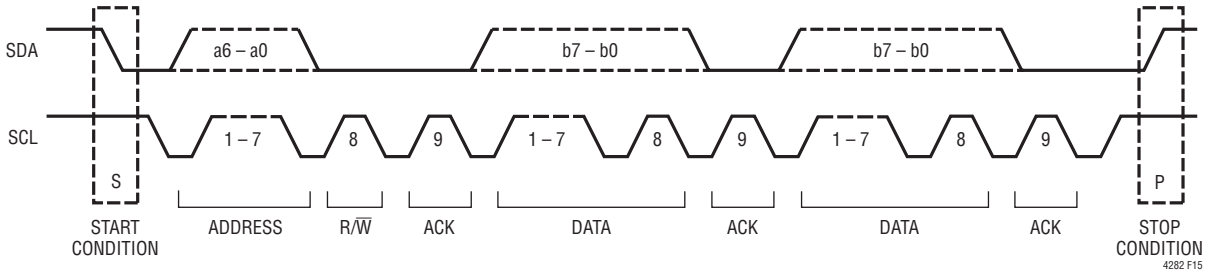

Figure 15. Data Transfer Over I<sup>2</sup>C or SMBus

S	ADDRESS	W	A	COMMAND	A	DATA	A	P
	1 0 a4:a0	0	0	b7:b0	0	b7:b0	0	

FROM MASTER TO SLAVE  
 FROM SLAVE TO MASTER  
 A: ACKNOWLEDGE (LOW)  
 $\bar{A}$ : NOT ACKNOWLEDGE (HIGH)  
 R: READ BIT (HIGH)  
 W: WRITE BIT (LOW)  
 S: START CONDITION  
 P: STOP CONDITION

S	ADDRESS	W	A	COMMAND	A	DATA	A	DATA	A	P
	1 0 a4:a0	0	0	b7:b0	0	b7:b0	0	b7:b0	0	

Figure 16. LTC4282 Serial Bus SDA Write Byte Protocol

Figure 17. LTC4282 Serial Bus SDA Write Word Protocol

S	ADDRESS	W	A	COMMAND	A	DATA	A	DATA	A	...	DATA	A	P
	1 0 a4:a0	0	0	b7:b0	0	b7:b0	0	b7:b0	0	...	b7:b0	0	

Figure 18. LTC4282 Serial Bus SDA Continuous Write Protocol

S	ADDRESS	W	A	COMMAND	A	S	ADDRESS	R	A	DATA	$\bar{A}$	P
	1 0 a4:a0	0	0	b7:b0	0		1 0 a4:a0	1	0	b7:b0	1	

Figure 19. LTC4282 Serial Bus SDA Read Byte Protocol

S	ADDRESS	W	A	COMMAND	A	S	ADDRESS	R	A	DATA	A	DATA	$\bar{A}$	P
	1 0 a4:a0	0	0	b7:b0	0		1 0 a4:a0	1	0	b7:b0	0	b7:b0	1	

Figure 20. LTC4282 Serial Bus SDA Read Word Protocol

S	ADDRESS	W	A	COMMAND	A	S	ADDRESS	R	A	DATA	A	DATA	A	...	DATA	$\bar{A}$	P
	1 0 a4:a0	0	0	b7:b0	0		1 0 a4:a0	1	0	b7:b0	0	b7:b0	0	...	b7:b0	1	

Figure 21. LTC4282 Serial Bus SDA Continuous Read Protocol

S	ALERT RESPONSE ADDRESS	R	A	DEVICE ADDRESS	$\bar{A}$	P
	0 0 0 1 1 0 0	1	0	1 0 a4:a0 0	1	

Figure 22. LTC4282 Serial Bus SDA Alert Response Protocol

## APPLICATIONS INFORMATION

### Data Synchronization

The ADC measurements and subsequent computed values are 16-48 bits wide, but must be read over I<sup>2</sup>C in 8-bit segments. To ensure that the words are not updated in the middle of reading them, the LTC4282 latches these results while the I<sup>2</sup>C interface is busy. As long as the ADC data is read out in a single transaction, all the data will be synchronized. A STOP condition frees the LTC4282 to update the ADC result registers. Status and fault registers are updated in real time.

### Alert Response Protocol

When any of the fault bits in FAULT\_LOG register 0x04 are set, an optional bus alert is generated if the appropriate bit in the ALERT register 0x02 is also set. If an alert is enabled, the corresponding fault causes the  $\overline{\text{ALERT}}$  pin to pull low. After the bus master controller broadcasts the Alert Response Address, the LTC4282 responds with its address on the SDA line and then releases  $\overline{\text{ALERT}}$  when it has successfully completed transmitting its address as shown in Figure 22.

The  $\overline{\text{ALERT}}$  signal is not pulled low again until the FAULT register 0x04 indicates a different fault as occurred or the original fault is cleared and it occurs again. Note that this means repeated or continuing faults do not generate alerts until the associated FAULT\_LOG register bit has been cleared.

### EEPROM

The LTC4282 has an onboard EEPROM to allow nonvolatile configuration and fault logging. The EEPROM registers are denoted by 'EE' in the first column of register Table 2. The EEPROM registers may be read and written like any other register except that the EEPROM takes about 2ms to write data. While the EEPROM is writing, the EEPROM\_BUSY bit, bit 3 in STATUS register 0x1F is set to 1. While the EEPROM is busy the I<sup>2</sup>C interface will NACK commands to read or write to EEPROM registers, but other registers may be accessed during this time. When the EEPROM finishes writing, the EEPROM\_BUSY bit will reset and the EEPROM\_DONE bit, bit 7 in FAULT\_LOG register 0x04 will be set. If configured to generate an alert

on EEPROM\_DONE, Bit 7 in ALERT register 0x02, the  $\overline{\text{ALERT}}$  pin will pull low to alert the host that the EEPROM write has finished and the LTC4282 EEPROM is ready to receive another byte.

When the LTC4282 comes out of UVLO or receives a REBOOT command the contents of the EEPROM are copied to the corresponding operating registers, which are offset from the EEPROM register addresses by 0x20. The SCRATCH\_PAD registers, 0x4C-0x4F, are free for general purpose use, such as storing fault history, serial numbers or calibration data. The factory default EEPROM contents will make the LTC4282 behave similar to the LTC4215 to ease design migration and provide a useful design starting point.

The ADC\_ALERT\_LOG register(0x05) is not loaded from the EEPROM at boot, and the FAULT\_LOG register (0x04) is only loaded at boot if the ON\_FAULT\_MASK bit is set in the EEPROM (bit 7, register 0x20). The register data is copied into the EEPROM when any of the bits in the log registers transition high and fault logging is enabled in ADC\_CONTROL register 0x1D. Fault logging is disabled by default after boot so that logged faults are not inadvertently cleared by powering up with a fault condition and overwriting the EEPROM. A 4.7 $\mu$ F capacitor on the INTV<sub>CC</sub> pin allows the LTC4282 to operate and log faults to the EEPROM if input power is lost. A 1 $\mu$ F capacitor may be used in applications that do not require EEPROM fault logging.

The WP pin prevents I<sup>2</sup>C writes to the EEPROM when high. Attempts to write to the EEPROM while WP is high will result in a NACK and no action. Usually the WP pin is tied high through a resistor with a probe pad to allow it to be pulled low manually; it may also be tied low to enable writes all the time or connected to a GPIO pin or other logic-level signal to allow software control of WP. The EEPROM may still be read when WP is high. The FAULT\_LOG and ADC\_ALERT\_LOG registers of the EEPROM will still log faults when the WP pin is high. LTC can provide programmed parts may which have WP locked in a high state to make it impossible to change the default configuration by any means. Please contact the factory.

## APPLICATIONS INFORMATION

Table 1. LTC4282 Addressing

DESCRIPTION	8-BIT DEVICE ADDRESS*	7-BIT DEVICE ADDRESS†	BINARY DEVICE ADDRESS								LTC4282 ADDRESS PINS		
	h		a6	a5	a4	a3	a2	a1	a0	R/W	ADR2	ADR1	ADRO
Mass Write	0xBE	0x5F	1	0	1	1	1	1	1	0	X	X	X
Alert Response	0x19	0x0C	0	0	0	1	1	0	0	1	X	X	X
64	0x80	0x40	1	0	0	0	0	0	0	X	L	NC	L
65	0x82	0x41	1	0	0	0	0	0	1	X	L	H	NC
66	0x84	0x42	1	0	0	0	0	1	0	X	L	NC	NC
67	0x86	0x43	1	0	0	0	0	1	1	X	L	NC	H
68	0x88	0x44	1	0	0	0	1	0	0	X	L	L	L
69	0x8A	0x45	1	0	0	0	1	0	1	X	L	H	H
70	0x8C	0x46	1	0	0	0	1	1	0	X	L	L	NC
71	0x8E	0x47	1	0	0	0	1	1	1	X	L	L	H
72	0x90	0x48	1	0	0	1	0	0	0	X	NC	NC	L
73	0x92	0x49	1	0	0	1	0	0	1	X	NC	H	NC
74	0x94	0x4A	1	0	0	1	0	1	0	X	NC	NC	NC
75	0x96	0x4B	1	0	0	1	0	1	1	X	NC	NC	H
76	0x98	0x4C	1	0	0	1	1	0	0	X	NC	L	L
77	0x9A	0x4D	1	0	0	1	1	0	1	X	NC	H	H
78	0x9C	0x4E	1	0	0	1	1	1	0	X	NC	L	NC
79	0x9E	0x4F	1	0	0	1	1	1	1	X	NC	L	H
80	0xA0	0x50	1	0	1	0	0	0	0	X	H	NC	L
81	0xA2	0x51	1	0	1	0	0	0	1	X	H	H	NC
82	0xA4	0x52	1	0	1	0	0	1	0	X	H	NC	NC
83	0xA6	0x53	1	0	1	0	0	1	1	X	H	NC	H
84	0xA8	0x54	1	0	1	0	1	0	0	X	H	L	L
85	0xAA	0x55	1	0	1	0	1	0	1	X	H	H	H
86	0xAC	0x56	1	0	1	0	1	1	0	X	H	L	NC
87	0xAE	0x57	1	0	1	0	1	1	1	X	H	L	H
88	0xB0	0x58	1	0	1	1	0	0	0	X	L	H	L
89	0xB2	0x59	1	0	1	1	0	0	1	X	NC	H	L
90	0xB4	0x5A	1	0	1	1	0	1	0	X	H	H	L

H = Tie to INTV<sub>CC</sub>, NC = No Connect, L = Tie to GND, X = Do Not Care.

\* 8-bit hexadecimal address with LSB R/W bit=0.

† 7-bit hexadecimal address with MSB a7=0.

## REGISTER SET

Table 2.

REGISTER NAME	COMMAND BYTE	DESCRIPTION	READ/ WRITE	DATA LENGTH	DEFAULT
CONTROL	0x00-0x01	Configures On/Off Behavior	RW	16 Bits	0xBB02
ALERT	0x02-0x03	Enables Alerts	RW	16 Bits	0x0000
FAULT_LOG	0x04	Logs Faults	RW	8 Bits	0x00
ADC_ALERT_LOG	0x05	Logs ADC Alerts	RW	8 Bits	0x00
FET_BAD_FAULT_TIME	0x06	Selects FET-BAD Fault Timeout	RW	8 Bits	0xFF
GPIO_CONFIG	0x07	Configures GPIO Outputs	RW	8 Bits	0x00
VGPI0_ALARM_MIN	0x08	Threshold For Min Alarm on VGPI0	RW	8 Bits	0x00
VGPI0_ALARM_MAX	0x09	Threshold for Max Alarm on VGPI0	RW	8 Bits	0xFF
VSOURCE_ALARM_MIN	0x0A	Threshold for Min Alarm on VSOURCE	RW	8 Bits	0x00
VSOURCE_ALARM_MAX	0x0B	Threshold for Max Alarm on VSOURCE	RW	8 Bits	0xFF
VSENSE_ALARM_MIN	0x0C	Threshold for Min Alarm on VSENSE	RW	8 Bits	0x00
VSENSE_ALARM_MAX	0x0D	Threshold for Max Alarm on VSENSE	RW	8 Bits	0xFF
POWER_ALARM_MIN	0x0E	Threshold for Min Alarm on POWER	RW	8 Bits	0x00
POWER_ALARM_MAX	0x0F	Threshold for Max Alarm on POWER	RW	8 Bits	0xFF
CLOCK_DIVIDER	0x10	Division Factor for External Clock	RW	8 Bits	0x08
ILIM_ADJUST	0x11	Adjusts Current Limit Value	RW	8 Bits	0x96
ENERGY	0x12-0x17	Meters Energy Delivered to Load	RW	48 Bits	0x000000
TIME_COUNTER	0x18-0x1B	Counts Power Delivery Time	RW	32 Bits	0x0000
ALERT_CONTROL	0x1C	Clear Alerts, Force ALERT Pin Low	RW	8 Bits	0x00
ADC_CONTROL	0x1D	Control ADC, Energy Meter	RW	8 Bits	0x00
STATUS	0x1E-0x1F	Fault and Pin Status	R	16 Bits	N/A
EE_CONTROL	0x20-0x21	EEPROM Default	RW	16 Bits	0xBB02
EE_ALERT	0x22-0x23	EEPROM Default	RW	16 Bits	0x0000
EE_FAULT_LOG	0x24	EEPROM Default	RW	8 Bits	0x00
EE_ADC_ALERT_LOG	0x25	EEPROM Default	RW	8 Bits	0x00
EE_FET_BAD_FAULT_TIME	0x26	EEPROM Default	RW	8 Bits	0xFF
EE_GPIO_CONFIG	0x27	EEPROM Default	RW	8 Bits	0x00
EE_VGPI0_ALARM_MIN	0x28	EEPROM Default	RW	8 Bits	0x00
EE_VGPI0_ALARM_MAX	0x29	EEPROM Default	RW	8 Bits	0xFF
EE_VSOURCE_ALARM_MIN	0x2A	EEPROM Default	RW	8 Bits	0x00
EE_VSOURCE_ALARM_MAX	0x2B	EEPROM Default	RW	8 Bits	0xFF
EE_VSENSE_ALARM_MIN	0x2C	EEPROM Default	RW	8 Bits	0x00
EE_VSENSE_ALARM_MAX	0x2D	EEPROM Default	RW	8 Bits	0xFF
EE_POWER_ALARM_MIN	0x2E	EEPROM Default	RW	8 Bits	0x00
EE_POWER_ALARM_MAX	0x2F	EEPROM Default	RW	8 Bits	0xFF
EE_CLOCK_DIVIDER	0x30	EEPROM Default	RW	8 Bits	0x08
EE_ILIM_ADJUST	0x31	EEPROM Default	RW	8 Bits	0x96
RESERVED	0x32-0x33	Reserved for Future Expansion, Do Not Write			N/A
VGPI0	0x34-0x35	Most Recent ADC Result for VGPI0	RW	16 Bits	N/A
VGPI0_MIN	0x36-0x37	Min ADC Result for VGPI0	RW	16 Bits	N/A

## REGISTER SET

Table 2.

REGISTER NAME	COMMAND BYTE	DESCRIPTION	READ/ WRITE	DATA LENGTH	DEFAULT
VGPI0_MAX	0x38-0x39	Max ADC Result for VGPI0	RW	16 Bits	N/A
VSOURCE	0x3A-0x3B	Most Recent ADC Result for VSOURCE	RW	16 Bits	N/A
VSOURCE_MIN	0x3C-0x3D	Min ADC Result for VSOURCE	RW	16 Bits	N/A
VSOURCE_MAX	0x3E-0x3F	Max ADC Result for VSOURCE	RW	16 Bits	N/A
VSENSE	0x40-0x41	Most Recent ADC Result for VSENSE	RW	16 Bits	N/A
VSENSE_MIN	0x42-0x43	Min ADC Result for VSENSE	RW	16 Bits	N/A
VSENSE_MAX	0x44-0x45	Max ADC Result for VSENSE	RW	16 Bits	N/A
POWER	0x46-0x47	Most Recent ADC Result for POWER	RW	16 Bits	N/A
POWER_MIN	0x48-0x49	Min ADC Result for POWER	RW	16 Bits	N/A
POWER_MAX	0x4A-0x4B	Max ADC Result for POWER	RW	16 Bits	N/A
EE_SCRATCH_PAD	0x4C-0x4F	Spare EEPROM Memory	RW	32 Bits	0x00000000
RESERVED	0x50-0xFF	Reserved for Future Expansion, Do Not Write			N/A

## DETAILED I<sup>2</sup>C COMMAND REGISTER DESCRIPTIONS

### CONTROL Registers (0x00–0x01) (Read/Write)

#### Byte 1 (0x00)

BIT(S)	NAME	DEFAULT	OPERATION
B[7]	ON_FAULT_MASK	1	If 1, blocks the ON pin from clearing the FAULT_LOG register to prevent repeated logged faults and alerts.
B[6]	ON_DELAY	0	If 1, a 50ms debounce is applied to the ON pin commanding the part to turn on, if 0 the part turns on immediately.
B[5]	ON/ENB	1	The ON pin is active high when this bit is a 1 and active low when this bit is a 0.
B[4]	MASS_WRITE_ENABLE	1	Writing a 1 enables MASS_WRITE to all LTC4282s on the I <sup>2</sup> C bus.
B[3]	FET_ON	1	Writing a 1 or 0 to this register turns the part on or off, overriding the ON pin.
B[2]	OC_AUTORETRY	0	Writing a 1 enables the part to auto-retry 256 timer cycles after an OC fault.
B[1]	UV_AUTORETRY	1	Writing a 1 enables the part to auto-retry 50ms after an UV fault.
B[0]	OV_AUTORETRY	1	Writing a 1 enables the part to auto-retry 50ms after an OV fault.

#### Byte 2 (0x01)

B[7-6]	FB_MODE	00	Selects threshold for POWER_GOOD, 00 = external, 01 = 5%, 10 = 10%, 11 = 15%.
B[5-4]	UV_MODE	00	Selects threshold for UV faults, 00 = external, 01 = 5%, 10 = 10%, 11 = 15%.
B[3-2]	OV_MODE	00	Selects threshold for OV faults, 00 = external, 01 = 5%, 10 = 10%, 11 = 15%.
B[1-0]	VIN_MODE	10	Selects operating range for UV/OV/FB and ADC: 00 = 3.3V, 01 = 5V, 10 = 12V, 11 = 24V.

## DETAILED I<sup>2</sup>C COMMAND REGISTER DESCRIPTIONS

### ALERT Registers (0x02–0x03) (Read/Write)

#### Byte 1 (0x02)

BIT(S)	NAME	DEFAULT	OPERATION
B[7]	EEPROM_DONE_ALERT	0	Writing a 1 generates alert when the EEPROM finishes writing.
B[6]	FET_BAD_FAULT_ALERT	0	Writing a 1 generates alert when FET-BAD faults are produced.
B[5]	FET_SHORT_ALERT	0	Writing a 1 generates alert when the ADC detects FET-short faults.
B[4]	ON_ALERT	0	Writing a 1 generates alert when the ON pin changes state.
B[3]	PB_ALERT	0	Writing a 1 generates alert when power-bad faults are produced.
B[2]	OC_ALERT	0	Writing a 1 generates alert when overcurrent faults are produced.
B[1]	UV_ALERT	0	Writing a 1 generates alert when undervoltage faults are produced.
B[0]	OV_ALERT	0	Writing a 1 generates alert when overvoltage faults are produced.

#### Byte 2 (0x03)

B[7]	POWER_ALERT_HIGH	0	Writing a 1 generates alert when the ADC result is at or above the POWER_ALARM_MAX threshold.
B[6]	POWER_ALERT_LOW	0	Writing a 1 generates alert when the ADC result is at or below the POWER_ALARM_MIN threshold.
B[5]	VSENSE_ALERT_HIGH	0	Writing a 1 generates alert when the ADC result is at or above the VSENSE_ALARM_MAX threshold.
B[4]	VSENSE_ALERT_LOW	0	Writing a 1 generates alert when the ADC result is at or below the VSENSE_ALARM_MIN threshold.
B[3]	VSOURCE_ALERT_HIGH	0	Writing a 1 generates alert when the ADC result is at or above the VSOURCE_ALARM_MAX threshold.
B[2]	VSOURCE_ALERT_LOW	0	Writing a 1 generates alert when the ADC result is at or below the VSOURCE_ALARM_MIN threshold.
B[1]	VGPIO_ALERT_HIGH	0	Writing a 1 generates alert when the ADC result is at or above the VGPIO_ALARM_MAX threshold.
B[0]	VGPIO_ALERT_LOW	0	Writing a 1 generates alert when the ADC result is at or below the VGPIO_ALARM_MIN threshold.

### FAULT\_LOG Register (0x04) (Read/Write)

#### Byte 1 (0x04)

BIT(S)	NAME	DEFAULT	OPERATION
B[7]	EEPROM_DONE	0	Set to 1 when the EEPROM finishes a write.
B[6]	FET_BAD_FAULT	0	Set to 1 when a FET-BAD fault occurs.
B[5]	FET_SHORT_FAULT	0	Set to 1 when the ADC detects a FET-short fault.
B[4]	ON_FAULT	0	Set to 1 by the ON pin changing state.
B[3]	POWER_BAD_FAULT	0	Set to 1 by a power-bad fault occurring.
B[2]	OC_FAULT	0	Set to 1 by an overcurrent fault occurring.
B[1]	UV_FAULT	0	Set to 1 by an undervoltage fault occurring.
B[0]	OV_FAULT	0	Set to 1 by an overvoltage fault occurring.

## DETAILED I<sup>2</sup>C COMMAND REGISTER DESCRIPTIONS

### ADC\_ALERT\_LOG Register (0x05) (Read/Write)

#### Byte 1 (0x05)

BIT(S)	NAME	DEFAULT	OPERATION
B[7]	POWER_ALARM_HIGH	0	Set to 1 when the ADC makes a measurement above the POWER_ALARM_MAX threshold
B[6]	POWER_ALARM_LOW	0	Set to 1 when the ADC makes a measurement below the POWER_ALARM_MIN threshold
B[5]	VSENSE_ALARM_HIGH	0	Set to 1 when the ADC makes a measurement above the VSENSE_ALARM_MAX threshold
B[4]	VSENSE_ALARM_LOW	0	Set to 1 when the ADC makes a measurement below the VSENSE_ALARM_MIN threshold
B[3]	VSOURCE_ALARM_HIGH	0	Set to 1 when the ADC makes a measurement above the VSOURCE_ALARM_MAX threshold
B[2]	VSOURCE_ALARM_LOW	0	Set to 1 when the ADC makes a measurement below the VSOURCE_ALARM_MIN threshold
B[1]	GPIO_ALARM_HIGH	0	Set to 1 when the ADC makes a measurement above the VGPIO_ALARM_MAX threshold
B[0]	GPIO_ALARM_LOW	0	Set to 1 when the ADC makes a measurement below the VGPIO_ALARM_MIN threshold

### FET\_BAD\_FAULT\_TIME Register (0x06) (Read/Write)

#### Byte 1 (0x06)

BIT(S)	NAME	DEFAULT	OPERATION
B[7-0]	FET_BAD_FAULT_TIMEOUT	255	Selects the wait time for a FET-bad fault as a binary integer in ms. 0x00 disables.

### GPIO\_CONFIG Register (0x07) (Read/Write)

#### Byte 1 (0x07)

BIT(S)	NAME	DEFAULT	OPERATION																				
B[7]	GPIO3_PD	0	A 1 in this value will make the GPIO3 pin pull low, a 0 will make the pin high impedance																				
B[6]	GPIO2_PD	0	A 1 in this value will make the GPIO2 pin pull low, a 0 will make the pin high impedance																				
B[5-4]	GPIO1_CONFIG	00	<table border="1"> <thead> <tr> <th>FUNCTION</th> <th>B[4]</th> <th>B[5]</th> <th>GPIO1 PIN</th> </tr> </thead> <tbody> <tr> <td>Power Good</td> <td>0</td> <td>0</td> <td>GPIO1 = Power Good</td> </tr> <tr> <td>Power Bad</td> <td>0</td> <td>1</td> <td>GPIO1 = Power Bad</td> </tr> <tr> <td>General Purpose Output</td> <td>1</td> <td>0</td> <td>GPIO1 = B[3]</td> </tr> <tr> <td>General Purpose Input</td> <td>1</td> <td>1</td> <td>GPIO1 = High-Z</td> </tr> </tbody> </table>	FUNCTION	B[4]	B[5]	GPIO1 PIN	Power Good	0	0	GPIO1 = Power Good	Power Bad	0	1	GPIO1 = Power Bad	General Purpose Output	1	0	GPIO1 = B[3]	General Purpose Input	1	1	GPIO1 = High-Z
FUNCTION			B[4]	B[5]	GPIO1 PIN																		
Power Good			0	0	GPIO1 = Power Good																		
Power Bad			0	1	GPIO1 = Power Bad																		
General Purpose Output	1	0	GPIO1 = B[3]																				
General Purpose Input	1	1	GPIO1 = High-Z																				
B[3]	GPIO1_OUTPUT	0	Output data bit to GPIO1 pin when configured as output (1 = high impedance, 0 = pull low)																				
B[2]	ADC_CONV_ALERT	0	Writing a 1 generates alert when the ADC finishes making a measurement																				
B[1]	STRESS_TO_GPIO2	0	Enables GPIO2 to pull low when the MOSFET is dissipating power (stress). Defined as both GATE to SOURCE voltages < 8V or $V_{DD} - V_{SOURCE} < 200mV$ .																				
B[0]	METER_OVERFLOW_ALERT	0	Writing a 1 generates alert when the energy meter accumulator or time counter overflows																				

## DETAILED I<sup>2</sup>C COMMAND REGISTER DESCRIPTIONS

### VGPIO\_ALARM\_MIN Register (0x08) (Read/Write)

#### Byte 1 (0x08)

BIT(S)	NAME	DEFAULT	OPERATION
B[7-0]	VGPIO_ALARM_MIN	0x00	Selects the maximum ADC measurement value that generates a VGPIO_MIN_ALARM

### VGPIO\_ALARM\_MAX Register (0x09) (Read/Write)

#### Byte 1 (0x09)

BIT(S)	NAME	DEFAULT	OPERATION
B[7-0]	VGPIO_ALARM_MAX	0xFF	Selects the minimum ADC measurement value that generates a VGPIO_MAX_ALARM

### VSOURCE\_ALARM\_MIN Register (0x0A) (Read/Write)

#### Byte 1 (0x0A)

BIT(S)	NAME	DEFAULT	OPERATION
B[7-0]	VSOURCE_ALARM_MIN	0x00	Selects the maximum ADC measurement value that generates a VSOURCE_MIN_ALARM

### VSOURCE\_ALARM\_MAX Register (0x0B) (Read/Write)

#### Byte 1 (0x0B)

BIT(S)	NAME	DEFAULT	OPERATION
B[7-0]	VSOURCE_ALARM_MAX	0xFF	Selects the minimum ADC measurement value that generates a VSOURCE_MAX_ALARM

## DETAILED I<sup>2</sup>C COMMAND REGISTER DESCRIPTIONS

### VSENSE\_ALARM\_MIN Register (0x0C) (Read/Write)

#### Byte 1 (0x0C)

BIT(S)	NAME	DEFAULT	OPERATION
B[7-0]	VSENSE_ALARM_MIN	0x00	Selects the maximum ADC measurement value that generates a VSENSE_MIN_ALARM

### VSENSE\_ALARM\_MAX Register (0x0D) (Read/Write)

#### Byte 1 (0x0D)

BIT(S)	NAME	DEFAULT	OPERATION
B[7-0]	VSENSE_ALARM_MAX	0xFF	Selects the minimum ADC measurement value that generates a VSENSE_MAX_ALARM

### POWER\_ALARM\_MIN Register (0x0E) (Read/Write)

#### Byte 1 (0x0E)

BIT(S)	NAME	DEFAULT	OPERATION
B[7-0]	POWER_ALARM_MIN	0x00	Selects the maximum ADC measurement value that generates a POWER_MIN_ALARM

### POWER\_ALARM\_MAX Register (0x0F) (Read/Write)

#### Byte 1 (0x0F)

BIT(S)	NAME	DEFAULT	OPERATION
B[7-0]	POWER_ALARM_MAX	0xFF	Selects the minimum ADC measurement value that generates a POWER_MAX_ALARM

### CLOCK\_DIVIDER Register (0x10) (Read/Write)

#### Byte 1 (0x10)

BIT(S)	NAME	DEFAULT	OPERATION
B[7]	COULOMB_METER	0	Setting this bit to a 1 configures the Energy meter to accumulate current instead of power, making it a Coulomb meter
B[6]	TICK_OUT	0	Writing a 1 configures the CLKOUT pin to output the internal time count (conversion time) as an open-drain output
B[5]	INT_CLK_OUT	0	Writing a 1 configures the CLKOUT pin to output the internal system clock as an open-drain output
B[4-0]	CLOCK_DIVIDER	01000	The clock frequency input on the CLKIN pin gets divided by twice this integer to produce the system clock at the target frequency of 250kHz. Code 00000 passes the clock without division

## DETAILED I<sup>2</sup>C COMMAND REGISTER DESCRIPTIONS

### ILIM\_ADJUST Register (0x11) (Read/Write)

#### Byte 1 (0x11)

BIT(S)	NAME	Default	Operation					
B[7-5]	ILIM_ADJUST	100	Selects the current limit values (mV)					
			<b>B[7]</b>	<b>B[6]</b>	<b>B[5]</b>	<b>FB = LOW</b>	<b>FB = HIGH</b>	<b>FAST COMPARATOR</b>
			0	0	0	3.75	12.5	38
			0	0	1	4.6875	15.625	47
			0	1	0	5.625	18.75	56
			0	1	1	6.5625	21.875	66
			1	0	0	7.5	25	75
			1	0	1	8.4375	28.125	84
1	1	0	9.375	31.25	94			
1	1	1	10.3125	34.375	103			
B[4-3]	FOLDBACK_MODE	10	Selects the voltage range for the internal current limit foldback profile: 00 = 3.3V, 01 = 5V, 10 = 12V, 11 = 24V					
B[2]	VSOURCE/VDD	1	Setting this bit to a 1 makes the ADC monitor the SOURCE voltage, 0 for V <sub>DD</sub>					
B[1]	GPIO_MODE	1	Setting this bit to a 1 makes the ADC monitor GPIO2, 0 for GPIO3					
B[0]	16_BIT	0	Setting this bit to a 1 will make the ADC operate in 16-bit mode, 0 will make the ADC operate in 12-bit mode					

### ENERGY Register (0x12–0x17) (Read/Write)

#### Byte 1-6 (0x12-0x17)

BIT(S)	NAME	DEFAULT	OPERATION
B[48-0]	ENERGY_METER	0x000000	Metered energy value

### TIME\_COUNTER Register (0x18–0x1B) (Read/Write)

#### Byte 1-4 (0x18-0x1B)

BIT(S)	NAME	DEFAULT	OPERATION
B[32-0]	TIME_COUNTER	0x0000	Counts the number of conversion cycles that power measurements have been accumulated in the energy meter

### ALERT\_CONTROL Register (0x1C) (Read/Write)

#### Byte 1 (0x1C)

BIT(S)	NAME	DEFAULT	OPERATION
B[7]	ALERT_GENERATED	0	This bit is set to 1 when an alert is generated. It must be manually cleared by writing a 0 to it via I <sup>2</sup> C. This bit can be set via I <sup>2</sup> C to simulate an alert
B[6]	ALERT_PD	0	When this bit is set to 1 the $\overline{\text{ALERT}}$ pin pulls low as a general purpose output low
B[5-0]	RESERVED	000000	Always read as 0

## DETAILED I<sup>2</sup>C COMMAND REGISTER DESCRIPTIONS

### ADC\_CONTROL Register (0x1D) (Read/Write)

#### Byte 1 (0x1D)

BIT(S)	NAME	DEFAULT	OPERATION
B[7]	REBOOT	0	Writing a 1 to this bit will cause the LTC4282 to turn off and reboot to the EEPROM default configuration and restart, if configured to do so, after 3.2s.
B[6]	METER_RESET	0	Writing a 1 to this bit resets the energy meter and tick counter and holds them reset until this bit is cleared.
B[5]	METER_HALT	0	Writing a 1 to this bit stops the meter and tick counter from accumulating until this bit is cleared.
B[4-3]	RESERVED	00	Always read as 0
B[2]	FAULT_LOG_ENABLE	0	Setting this bit to 1 enables registers 0x04 and 0x05 to be written to the EEPROM when a fault bit transitions high.
B[1]	GATEUP	GATELOW	Gives the status of the GATE pins, 0 if one of the GATE pins is higher than 8V (Read Only)
B[0]	ADC_HALT	0	Single shot mode, writing to this register again with HALT = 1 will allow the ADCs to make a single conversion and then stop, clearing this bit allows the ADCs to run continuously

### STATUS Register (0x1E–0x1F) (Read Only)

#### Byte 1 (0x1E)

BIT(S)	NAME	OPERATION
B[7]	ON_STATUS	A1 indicates if the MOSFETs are commanded to turn on
B[6]	FET_BAD_COOLDOWN_STATUS	A1 indicates that an FET-BAD fault has occurred and the part is going through a cool-down cycle
B[5]	FET_SHORT_PRESENT	A1 indicates that the ADCs have detected a shorted MOSFET
B[4]	ON_PIN_STATUS	A1 indicates the status of the ON pin, 1 = high
B[3]	POWER_GOOD_STATUS	A1 indicates if the output voltage is greater than the power good threshold
B[2]	OC_COOLDOWN_STATUS	A1 indicates that an overcurrent fault has occurred and the part is going through a cool-down cycle.
B[1]	UV_STATUS	A1 indicates that the input voltage is below the undervoltage threshold
B[0]	OV_STATUS	A1 indicates that the input voltage is above the overvoltage threshold

#### Byte 2 (0x1F)

B[7]	GPIO3_STATUS	A1 indicates that the GPIO3 pin is above its input threshold
B[6]	GPIO2_STATUS	A1 indicates that the GPIO2 pin is above its input threshold
B[5]	GPIO1_STATUS	A1 indicates that the GPIO1 pin is above its input threshold
B[4]	ALERT_STATUS	A1 indicates that the $\overline{\text{ALERT}}$ pin is above its input threshold
B[3]	EEPROM_BUSY	This bit is high whenever the EEPROM is writing, and indicates that the EEPROM is not available until the write is complete
B[2]	ADC_IDLE	This bit indicates that the ADC is idle. It is always read as 0 when the ADCs are free running, and will read a 1 when the ADC is idle in single shot mode
B[1]	TICKER_OVERFLOW_PRESENT	A1 indicates that the tick counter has overflowed
B[0]	METER_OVERFLOW_PRESENT	A1 indicates that the energy meter accumulator has overflowed

## DETAILED I<sup>2</sup>C COMMAND REGISTER DESCRIPTIONS

### EE\_CONTROL Non-Volatile Register (0x20–0x21) (Read/Write)

#### Byte 1 (0x20)

BIT(S)	NAME	DEFAULT	OPERATION
B[7]	Same as CONTROL 0x00	1	Sets default state for ON_FAULT_MASK bit. A 1 also allows the contents of EE_FAULT_LOG register 0x24 to be copied to FAULT_LOG 0x04 at boot.
B[6-4]	Same as CONTROL 0x00	011	Stores default state for CONTROL byte 1 (0x00) in nonvolatile memory
B[3]	Same as CONTROL 0x00	1	Sets the default ON state. 0 = OFF; 1 = ON-pin state.
B[2-0]	Same as CONTROL 0x00	011	Sets the default auto-retry behavior

#### Byte 2 (0x21)

B[7-0]	Same as CONTROL 0x01	0x02	Stores default state for CONTROL byte 2 (0x01) in nonvolatile memory
--------	----------------------	------	--

### EE\_ALERT Non-Volatile Register (0x22-0x23) (Read/Write)

#### Byte 1 (0x22)

BIT(S)	NAME	DEFAULT	OPERATION
B[7-0]	Same as ALERT 0x02	0x00	Stores default state for ALERT byte 1 (0x02) in nonvolatile memory

#### Byte 2 (0x23)

B[7-0]	Same as ALERT 0x03	0x00	Stores default state for ALERT byte 2 (0x03) in nonvolatile memory
--------	--------------------	------	--

### EE\_FAULT\_LOG Non-Volatile Register (0x24) (Read/Write)

#### Byte 1 (0x24)

BIT(S)	NAME	DEFAULT	OPERATION
B[7]	Same as FAULT_LOG	0x00	When a new fault occurs, the contents of FAULT_LOG register (0x04) are copied to this nonvolatile memory location

### EE\_ADC\_ALERT\_LOG Non-Volatile Register (0x25) (Read/Write)

#### Byte 1 (0x25)

BIT(S)	NAME	DEFAULT	OPERATION
B[7]	Same as ADC_ALERT_LOG	0x00	When a new ADC Alert is generated, the contents of ADC_ALERT_LOG register (0x05) are copied to this nonvolatile memory location

### EE\_FET\_BAD\_FAULT\_TIME Non-Volatile Register (0x26) (Read/Write)

#### Byte 1 (0x26)

BIT(S)	NAME	DEFAULT	OPERATION
B[7-0]	Same as FET_BAD_FAULT_TIME	0xFF	Stores default state for the FET_BAD_FAULT_TIME register (0x06) in nonvolatile memory

### EE\_GPIO\_CONFIG Non-Volatile Register (0x27) (Read/Write)

#### Byte 1 (0x27)

BIT(S)	NAME	DEFAULT	OPERATION
B[7-0]	Same as GPIO_CONFIG	0x00	Stores default state for GPIO Config register (0x07) in nonvolatile memory

## DETAILED I<sup>2</sup>C COMMAND REGISTER DESCRIPTIONS

### EE\_VGPIO\_ALARM\_MIN Non-Volatile Register (0x28) (Read/Write)

#### Byte 1 (0x28)

BIT(S)	NAME	DEFAULT	OPERATION
B[7-0]	VGPIO_ALARM_MIN	0x00	Stores default state for VGPIO_ALARM_MIN register (0x08) in nonvolatile memory

### EE\_VGPIO\_ALARM\_MAX Non-Volatile Register (0x29) (Read/Write)

#### Byte 1 (0x29)

BIT(s)	NAME	Default	Operation
B[7-0]	VGPIO_ALARM_MAX	0xFF	Stores default state for VGPIO_ALARM_MAX register (0x09) in nonvolatile memory

### EE\_VSOURCE\_ALARM\_MIN Non-Volatile Register (0x2A) (Read/Write)

#### Byte 1 (0x2A)

BIT(s)	NAME	Default	Operation
B[7-0]	VSOURCE_ALARM_MIN	0x00	Stores default state for VSOURCE_ALARM_MIN register (0x0A) in nonvolatile memory

### EE\_VSOURCE\_ALARM\_MAX Non-Volatile Register (0x2B) (Read/Write)

#### Byte 1 (0x2B)

BIT(s)	NAME	Default	Operation
B[7-0]	VSOURCE_ALARM_MAX	0xFF	Stores default state for VSOURCE_ALARM_MAX register (0x0B) in nonvolatile memory

### EE\_VSENSE\_ALARM\_MIN Non-Volatile Register (0x2C) (Read/Write)

#### Byte 1 (0x2C)

BIT(S)	NAME	DEFAULT	OPERATION
B[7-0]	VSENSE_ALARM_MIN	0x00	Stores default state for VSENSE_ALARM_MIN register (0x0C) in nonvolatile memory

### EE\_VSENSE\_ALARM\_MAX Non-Volatile Register (0x2D) (Read/Write)

#### Byte 1 (0x2D)

BIT(S)	NAME	DEFAULT	OPERATION
B[7-0]	VSENSE_ALARM_MAX	0xFF	Stores default state for VSENSE_ALARM_MAX register (0x0D) in nonvolatile memory

### EE\_POWER\_ALARM\_MIN Non-Volatile Register (0x2E) (Read/Write)

#### Byte 1 (0x2E)

BIT(S)	NAME	DEFAULT	OPERATION
B[7-0]	POWER_ALARM_MIN	0x00	Stores default state for POWER_ALARM_MIN register (0x0E) in nonvolatile memory

### EE\_POWER\_ALARM\_MAX Non-Volatile Register (0x2F) (Read/Write)

#### Byte 1 (0x2F)

BIT(S)	NAME	DEFAULT	OPERATION
B[7-0]	POWER_ALARM_MAX	0xFF	Stores default state for POWER_ALARM_MAX register (0x0F) in nonvolatile memory

## DETAILED I<sup>2</sup>C COMMAND REGISTER DESCRIPTIONS

### EE\_CLOCK\_DIVIDER Non-Volatile Register (0x30) (Read/Write)

#### Byte 1 (0x30)

BIT(S)	NAME	DEFAULT	OPERATION
B[7-0]	Same as CLOCK_DIVIDER	0x08	Stores default state for CLOCK_DIVIDER register (0x10) in nonvolatile memory

### EE\_ILIM\_ADJUST Non-Volatile Register (0x31) (Read/Write)

#### Byte 1 (0x31)

BIT(S)	NAME	DEFAULT	OPERATION
B[7-0]	Same as ILIM_ADJUST	96h	Stores default state for ILIM_ADJUST register (0x11) in nonvolatile memory

### Reserved Register (0x32–0x33) (Read Only)

#### Byte 1 (0x32)

BIT(S)	NAME	OPERATION
B[7-0]	Reserved	Always read as 0x00

#### Byte 2 (0x33)

B[7-0]	Reserved	Always read as 0x00
--------	----------	---------------------

### VGPI0 Register (0x34–0x35) (Read/Write)

#### Byte 1 (0x34)

BIT(S)	NAME	OPERATION
B[7-0]	VGPI0_MSB	Stores the MSBs for the most recent VGPI0 measurement result

#### Byte 2 (0x35)

B[7-0]	VGPI0_LSB	Stores the LSBs for the most recent VGPI0 measurement result
--------	-----------	--

### VGPI0\_MIN Register (0x36–0x37) (Read/Write)

#### Byte 1 (0x36)

BIT(S)	NAME	OPERATION
B[7-0]	VGPI0_MIN_MSB	Stores the MSBs for the smallest VGPI0 measurement result

#### Byte 2 (0x37)

B[7-0]	VGPI0_MIN_LSB	Stores the LSBs for the smallest VGPI0 measurement result
--------	---------------	---

### VGPI0\_MAX Register(0x38–0x39) (Read/Write)

#### Byte 1 (0x38)

BIT(S)	NAME	OPERATION
B[7-0]	VGPI0_MAX_MSB	Stores the MSBs for the largest VGPI0 measurement result

#### Byte 2 (0x39)

B[7-0]	VGPI0_MAX_LSB	Stores the LSBs for the largest VGPI0 measurement result
--------	---------------	--

## DETAILED I<sup>2</sup>C COMMAND REGISTER DESCRIPTIONS

### VSOURCE Register (0x3A–0x3B) (Read/Write)

#### Byte 1 (0x3A)

BIT(S)	NAME	OPERATION
B[7-0]	VSOURCE_MSB	Stores the MSBs for the most recent VSOURCE measurement result

#### Byte 2 (0x3B)

B[7-0]	VSOURCE_LSB	Stores the LSBs for the most recent VSOURCE measurement result
--------	-------------	--

### VSOURCE\_MIN Register (0x3C–0x3D) (Read/Write)

#### Byte 1 (0x3C)

BIT(S)	NAME	OPERATION
B[7-0]	VSOURCE_MIN_MSB	Stores the MSBs for the smallest VSOURCE measurement result

#### Byte 2 (0x3D)

B[7-0]	VSOURCE_MIN_LSB	Stores the LSBs for the smallest VSOURCE measurement result
--------	-----------------	---

### VSOURCE\_MAX Register (0x3E–0x3F) (Read/Write)

#### Byte 1 (0x3E)

BIT(S)	NAME	OPERATION
B[7-0]	VSOURCE_MAX_MSB	Stores the MSBs for the largest VSOURCE measurement result

#### Byte 2 (0x3F)

B[7-0]	VSOURCE_MAX_LSB	Stores the LSBs for the largest VSOURCE measurement result
--------	-----------------	--

### VSENSE Register (0x40–0x41) (Read/Write)

#### Byte 1 (0x40)

BIT(S)	NAME	OPERATION
B[7-0]	VSENSE_MSB	Stores the MSBs for the most recent VSENSE measurement result

#### Byte 2 (0x41)

B[7-0]	VSENSE_LSB	Stores the LSBs for the most recent VSENSE measurement result
--------	------------	---

### VSENSE\_MIN Register (0x42–0x43) (Read/Write)

#### Byte 1 (0x42)

BIT(S)	NAME	OPERATION
B[7-0]	VSENSE_MIN_MSB	Stores the MSBs for the smallest VSENSE measurement result

#### Byte 2 (0x43)

B[7-0]	VSENSE_MIN_LSB	Stores the LSBs for the smallest VSENSE measurement result
--------	----------------	--

### VSENSE\_MAX Register (0x44–0x45) (Read/Write)

#### Byte 1 (0x44)

BIT(S)	NAME	OPERATION
B[7-0]	VSENSE_MAX_MSB	Stores the MSBs for the largest VSENSE measurement result

#### Byte 2 (0x45)

B[7-0]	VSENSE_MAX_LSB	Stores the LSBs for the largest VSENSE measurement result
--------	----------------	---

## DETAILED I<sup>2</sup>C COMMAND REGISTER DESCRIPTIONS

### POWER Register (0x46–0x47) (Read/Write)

#### Byte 1 (0x46)

BIT(S)	NAME	OPERATION
B[7-0]	POWER_MSB	Stores the MSBs for the most recent POWER measurement result

#### Byte 2 (0x47)

B[7-0]	POWER_LSB	Stores the LSBs for the most recent POWER measurement result
--------	-----------	--

### POWER\_MIN Register (0x48–0x49) (Read/Write)

#### Byte 1 (0x48)

BIT(S)	NAME	OPERATION
B[7-0]	POWER_MIN_MSB	Stores the MSBs for the smallest POWER measurement result

#### Byte 2 (0x49)

B[7-0]	POWER_MIN_LSB	Stores the LSBs for the smallest POWER measurement result
--------	---------------	---

### POWER\_MAX Register (0x4A–0x4B) (Read/Write)

#### Byte 1 (0x4A)

BIT(S)	NAME	OPERATION
B[7-0]	POWER_MAX_MSB	Stores the MSBs for the largest POWER measurement result

#### Byte 2 (0x4B)

B[7-0]	POWER_MAX_LSB	Stores the LSBs for the largest POWER measurement result
--------	---------------	--

### EE\_SCRATCH\_PAD Non-Volatile Register (0x4C–0x4F) (Read/Write)

#### Byte 1 (0x4C)

BIT(S)	NAME	DEFAULT	OPERATION
B[7-0]	SCRATCH_PAD_1	0x00	Uncommitted nonvolatile memory

#### Byte 2 (0x4D)

B[7-0]	SCRATCH_PAD_2	0x00	Uncommitted nonvolatile memory
--------	---------------	------	--------------------------------

#### Byte 3 (0x4E)

B[7-0]	SCRATCH_PAD_3	0x00	Uncommitted nonvolatile memory
--------	---------------	------	--------------------------------

#### Byte 4 (0x4F)

B[7-0]	SCRATCH_PAD_4	0x00	Uncommitted nonvolatile memory
--------	---------------	------	--------------------------------

## TYPICAL APPLICATIONS

### 12V, 100A Backplane Resident Parallel Application

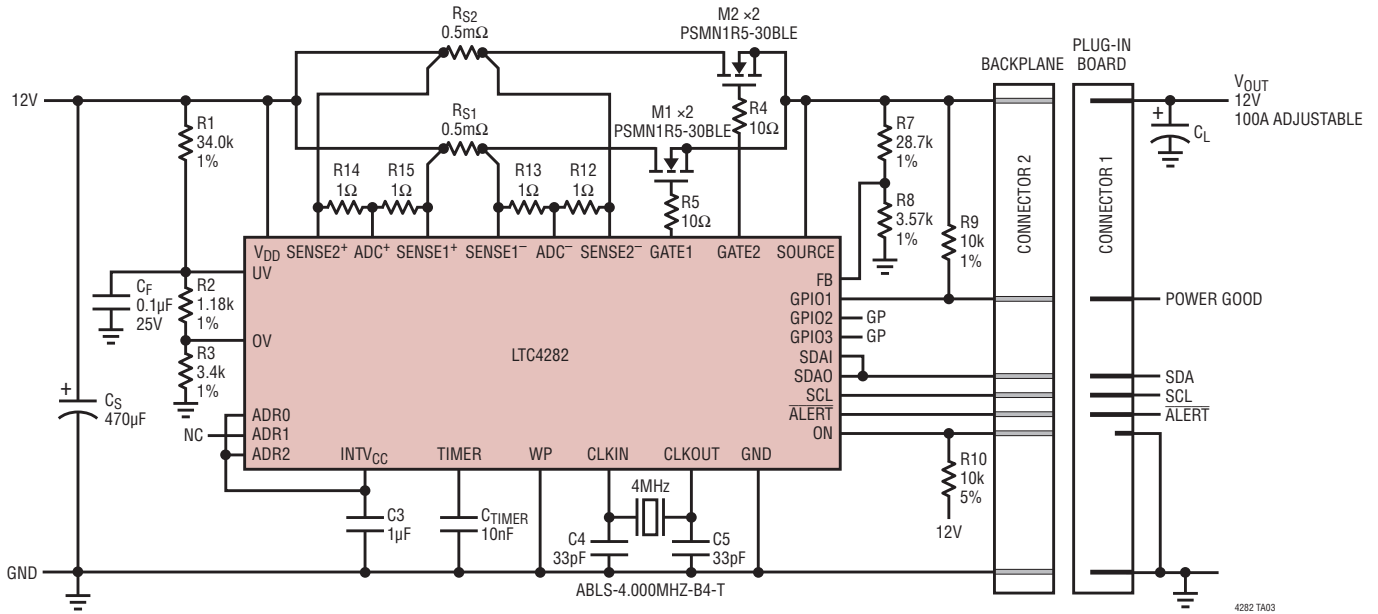

4282 TA03

# TYPICAL APPLICATIONS

200A Low Stress Staged Start Application, See DC2442 for More Information

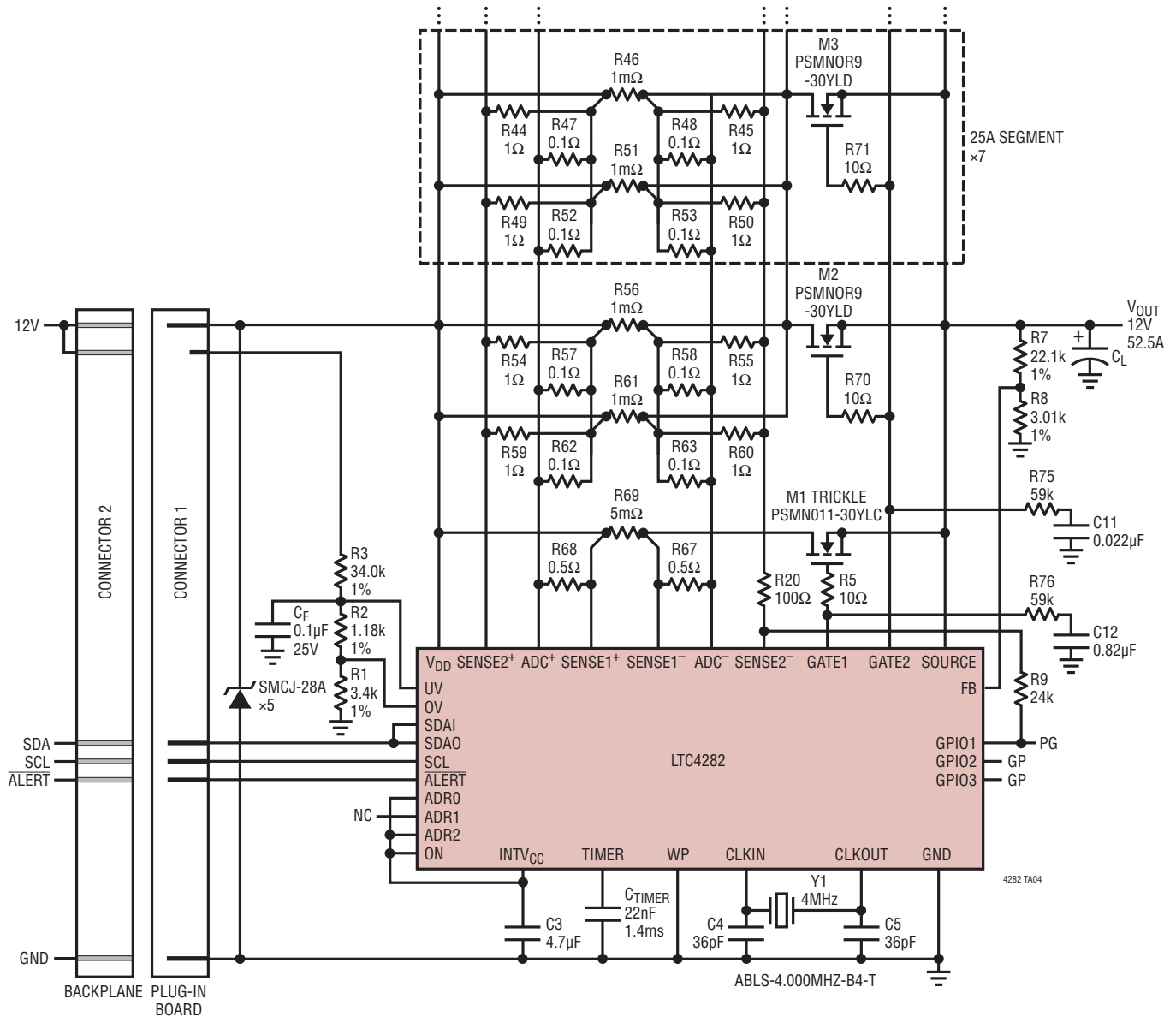

**PACKAGE DESCRIPTION**

**UH Package**  
**32-Lead Plastic QFN (5mm × 5mm)**  
 (Reference LTC DWG # 05-08-1693 Rev D)

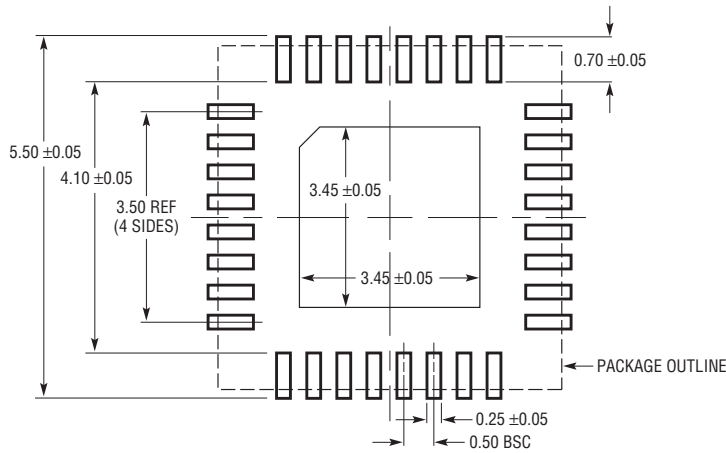

RECOMMENDED SOLDER PAD LAYOUT  
 APPLY SOLDER MASK TO AREAS THAT ARE NOT SOLDERED

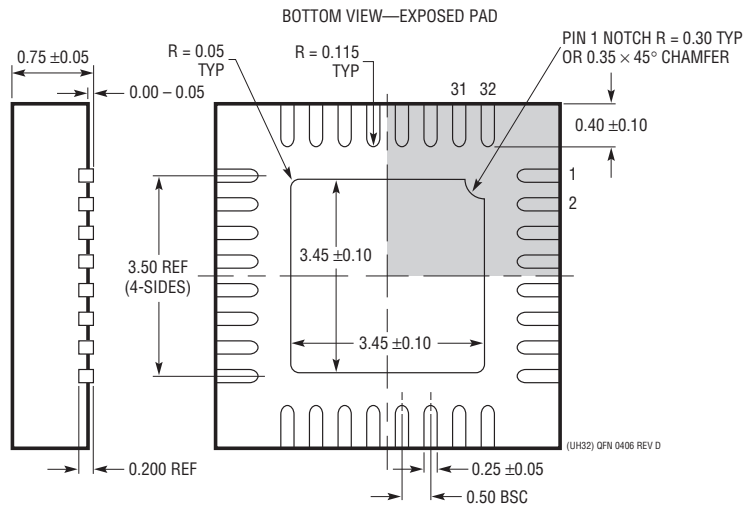
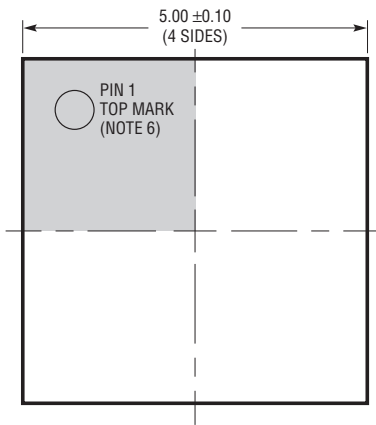

- NOTE:
1. DRAWING PROPOSED TO BE A JEDEC PACKAGE OUTLINE  
 MO-220 VARIATION WHHD-(X) (TO BE APPROVED)
  2. DRAWING NOT TO SCALE
  3. ALL DIMENSIONS ARE IN MILLIMETERS
  4. DIMENSIONS OF EXPOSED PAD ON BOTTOM OF PACKAGE DO NOT INCLUDE  
 MOLD FLASH. MOLD FLASH, IF PRESENT, SHALL NOT EXCEED 0.20mm ON ANY SIDE
  5. EXPOSED PAD SHALL BE SOLDER PLATED
  6. SHADED AREA IS ONLY A REFERENCE FOR PIN 1 LOCATION  
 ON THE TOP AND BOTTOM OF PACKAGE

## REVISION HISTORY

REV	DATE	DESCRIPTION	PAGE NUMBER
A	12/18	Updated graph for MOSFET Power Limit (G05).	7
		Added a section on constant current startup.	15
		Added $D_G$ to Figure 4.	18
		Updated equations to calculate R2, R3, and R7.	27, 28
		Updated sections: Resetting Faults in FAULT_LOG, Layout Considerations, EEPROM, EE_CONTROL register, Typical Application.	23, 28, 31, 41, 46
B	03/20	Added AEC-Q100 qualification and "W" part numbers.	1, 3
		Changed $t_{HD,STA(MIN)}$ unit.	6
		Changed $t_{SU,DAT(MIN)}$ max limit.	6
		Changed Q1 and Q2 to M1 and M2 respectively, and increased quantities to two in Figure 1.	13
		Corrected OVERFLOW_PRESENT bit references.	22
		Corrected data converter 12-/16-bit mode references.	23
C	03/22	Updated ADC TUE value on features section.	1
		Added A-grade part number and removed C-grade and I-grade part numbers from Order Information.	3
		Updated min/max specs for the following parameters: $V_{DD(UVL)-RISING}$ ; $V_{DD(HYST)}$ ; $INTV_{CC(UVL)}$ .	
		Added $V_{DD(UVL)-FALLING}$ specification.	
		Updated min/max specs for the following parameters: $INTV_{CC(HYST)}$ ; $\Delta V_{SENSE}$ ; $\Delta V_{SENSE1} - \Delta V_{SENSE2}$ ; $I_{SENSE+}$ ; $V_{TH-R}$ ; $V_{TH-F}$ ; $V_{HYST}$ ; $V_{TH}$ .	4
		Added specifications: $INTV_{CC}$ ; $V_{TH-F}$ - UV, OV, FB, ON Falling Threshold; $V_{TH-R}$ - WP Threshold Voltage.	
		Updated min/max specs for the following parameters: $V_{HYST}$ ; $I_{OH}$ ; TUE; FSE; INL.	5
		Added specification: $V_{TH-R}$ - GPIO, ALERT, Threshold.	

## TYPICAL APPLICATION

### Low Stress, Staged Start 12V, 50A Application

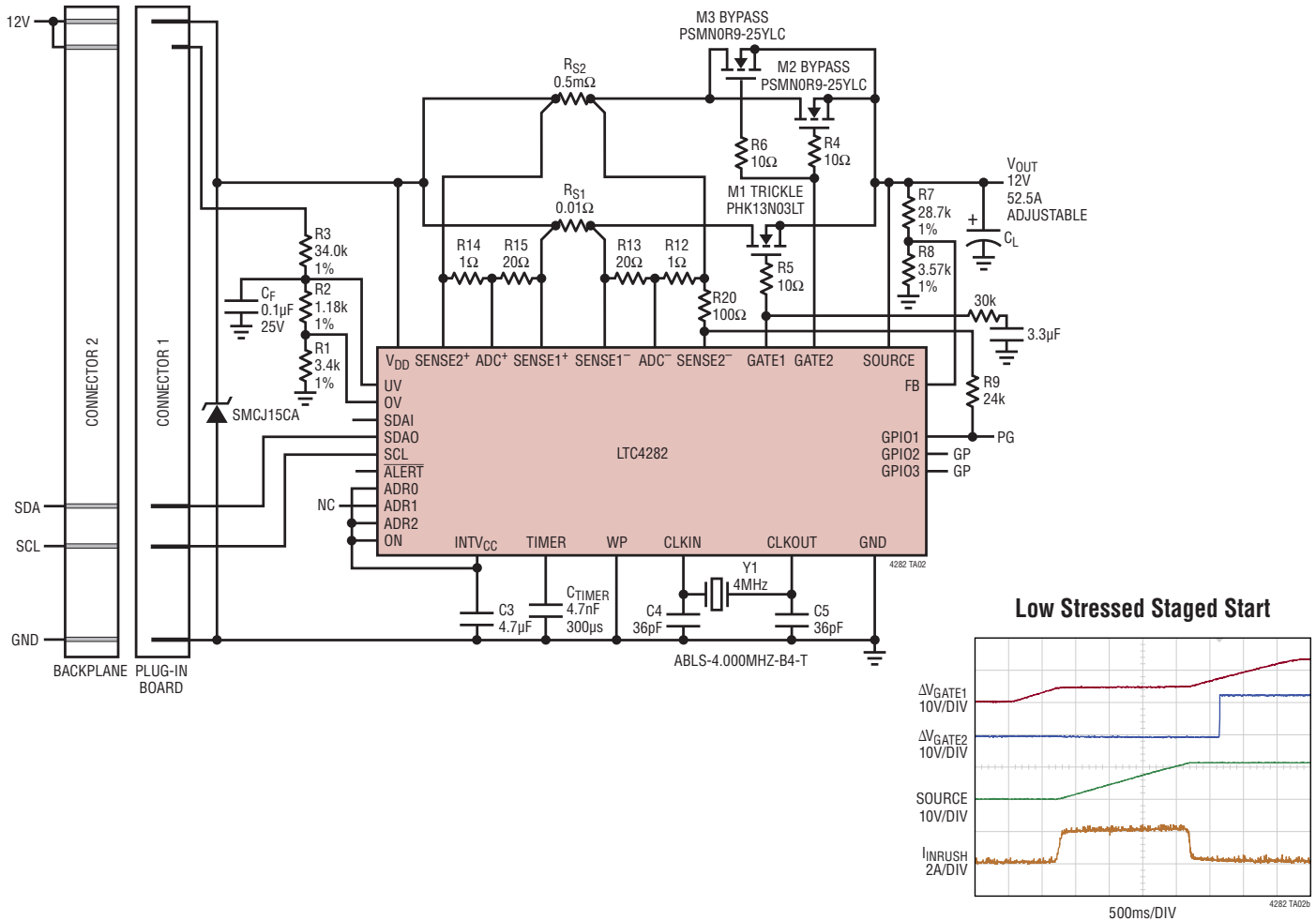

## RELATED PARTS

PART NUMBER	DESCRIPTION	COMMENTS
<a href="#">LTC4151</a>	High Voltage Current and Voltage Monitor with ADC and I <sup>2</sup> C	7V to 80V Single Voltage/Current Monitor with 12-Bit ADC
<a href="#">LTC4210</a>	Hot Swap Controller	Operates from 2.7V to 16.5V, Active Current Limiting, SOT23-6
<a href="#">LTC4211</a>	Hot Swap Controller	Operates from 2.5V to 16.5V, Multifunction Current Control, SO-8, MSOP-8 or MSOP-10
<a href="#">LTC4212</a>	Hot Swap Controller	Operates from 2.5V to 16.5V, Power-Up Timeout, MSOP-10
<a href="#">LTC4215</a>	Hot Swap Controller with I <sup>2</sup> C	Internal 8-Bit ADC, dI/dt Controlled Soft-Start
<a href="#">LTC4216</a>	Hot Swap Controller	Operates from 0V to 6V, MSOP-10 or 12-Lead (4mm × 3mm) DFN
<a href="#">LTC4222</a>	Dual Hot Swap Controller with ADC and I <sup>2</sup> C	2.9V to 29V Dual Controller with 10-Bit ADC, dI/dt Controlled Soft-Start
<a href="#">LTC4245</a>	Multiple Supply CompactPCI or PCI Express Hot Swap Controller with I <sup>2</sup> C	Internal 8-Bit ADC, dI/dt Controlled Soft-Start
<a href="#">LTC4260</a>	High Voltage Hot Swap Controller with ADC and I <sup>2</sup> C	8-Bit ADC Monitoring Current and Voltages, Supplies from 8.5V to 80V
<a href="#">LTC4261</a>	Negative High Voltage Hot Swap Controller with ADC and I <sup>2</sup> C	10-Bit ADC Monitoring Current and Voltages, Supplies from -12V to -100V
<a href="#">LTC4280</a>	Hot Swap Controller with I <sup>2</sup> C	Internal 8-Bit ADC, Adjustable Short-Circuit Filter Time
<a href="#">LTC4281</a>	Hot Swap Controller with I <sup>2</sup> C and EEPROM	2.9V to 33V Operation, 12-/16-bit ADC, Power and Energy Monitoring

## Looking for pricing, stock, or lifecycle information?

Click below to explore more details on WIN SOURCE:

 [View LTC4282IUH#TRPBF on WIN SOURCE](#)

 [Analog Devices Inc. Information](#)

## Optimize Your Supply Chain with WIN SOURCE Solutions

-  Global Sourcing Solution
-  Obsolete Management
-  Cost Control Management
-  Shortage Management
-  Alternative Solution
-  Excess Inventory Management