

PIN CONFIGURATION

48-pin Mini BGA (B) (6mm x 8mm)

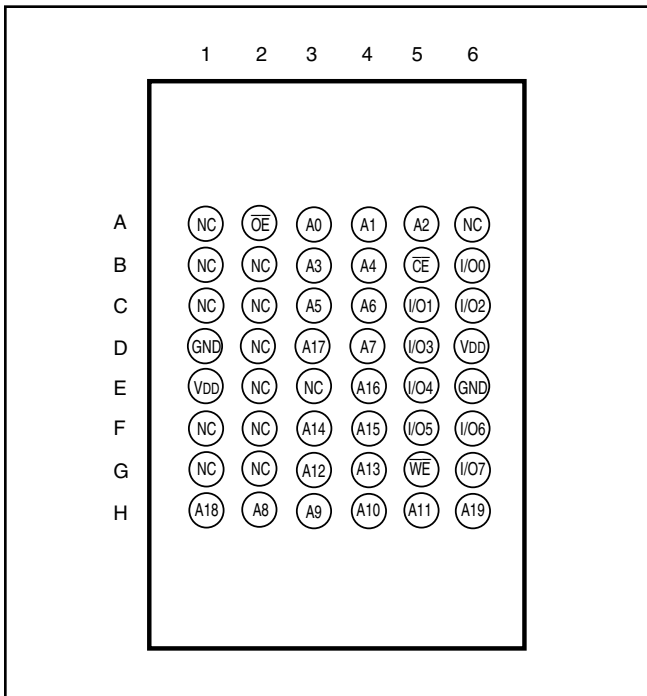

44-pin TSOP (Type II)

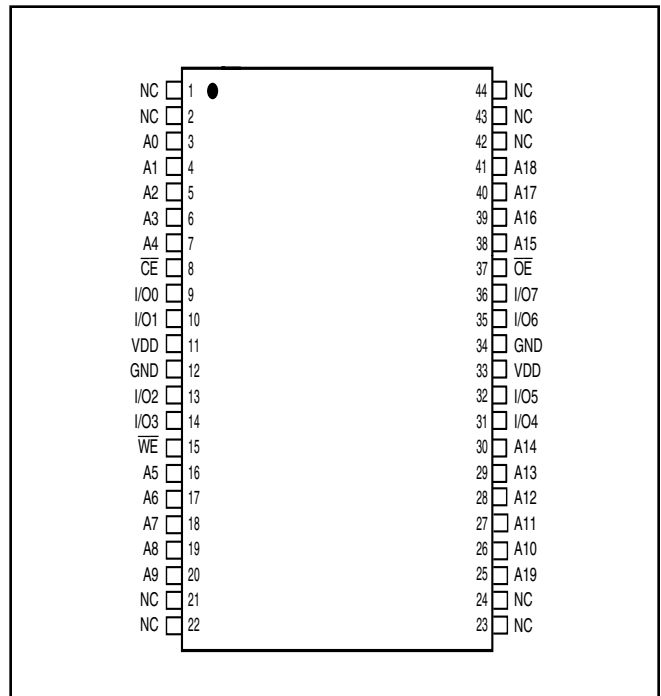

PIN DESCRIPTIONS

A0-A19 Address Inputs

\overline{CE} Chip Enable Input

\overline{OE} Output Enable Input

\overline{WE} Write Enable Input

I/O0-I/O7 Data Input / Output

VDD Power

GND Ground

NC No Connection

TRUTH TABLE

Mode	\overline{WE}	\overline{CE}	\overline{OE}	I/O Operation	V _{DD} Current
Not Selected (Power-down)	X	H	X	High-Z	I _{SB1} , I _{SB2}
Output Disabled	H	L	H	High-Z	I _{CC}
Read	H	L	L	D _{OUT}	I _{CC}
Write	L	L	X	D _{IN}	I _{CC}

ABSOLUTE MAXIMUM RATINGS⁽¹⁾

Symbol	Parameter	Value	Unit
V _{TERM}	Terminal Voltage with Respect to GND	-0.5 to V _{DD} + 0.5	V
V _{DD}	V _{DD} Relates to GND	-0.3 to 4.0	V
T _{STG}	Storage Temperature	-65 to +150	°C
P _T	Power Dissipation	1.0	W

Notes:

1. Stress greater than those listed under ABSOLUTE MAXIMUM RATINGS may cause permanent damage to the device. This is a stress rating only and functional operation of the device at these or any other conditions above those indicated in the operational sections of this specification is not implied. Exposure to absolute maximum rating conditions for extended periods may affect reliability.

CAPACITANCE^(1,2)

Symbol	Parameter	Conditions	Max.	Unit
C _{IN}	Input Capacitance	V _{IN} = 0V	6	pF
C _{I/O}	Input/Output Capacitance	V _{OUT} = 0V	8	pF

Notes:

1. Tested initially and after any design or process changes that may affect these parameters.
2. Test conditions: T_A = 25°C, f = 1 MHz, V_{DD} = 3.3V.

OPERATING RANGE (V_{DD})¹

Range	Ambient Temperature	IS61WV10248EDBLL V _{DD} (8, 10ns)	IS64WV10248EDBLL V _{DD} (10ns)
Industrial	-40°C to +85°C	2.4V-3.6V	—
Automotive (A1)	-40°C to +85°C	—	2.4V-3.6V
Automotive (A3)	-40°C to +125°C	—	2.4V-3.6V

Note:

1. Contact SRAM@issi.com for 1.8V option

ERROR DETECTION AND ERROR CORRECTION

- Independent ECC with hamming code for each byte
- Detect and correct one bit error per byte
- Better reliability than parity code schemes which can only detect an error but not correct an error
- Backward Compatible: Drop in replacement to current in industry standard devices (without ECC)

DC ELECTRICAL CHARACTERISTICS (Over Operating Range)

V_{DD} = 2.4V-3.6V

Symbol	Parameter	Test Conditions	Min.	Max.	Unit
V _{OH}	Output HIGH Voltage	V _{DD} = Min., I _{OH} = -1.0 mA	1.8	—	V
V _{OL}	Output LOW Voltage	V _{DD} = Min., I _{OL} = 1.0 mA	—	0.4	V
V _{IH}	Input HIGH Voltage		2.0	V _{DD} + 0.3	V
V _{IL}	Input LOW Voltage ⁽¹⁾		-0.3	0.8	V
I _{LI}	Input Leakage	GND ≤ V _{IN} ≤ V _{DD}	-1	1	μA
I _{LO}	Output Leakage	GND ≤ V _{OUT} ≤ V _{DD} , Outputs Disabled	-1	1	μA

Note:

- V_{IL} (min.) = -0.3V DC; V_{IL} (min.) = -2.0V AC (pulse width ≤ 2 ns). Not 100% tested.
V_{IH} (max.) = V_{DD} + 0.3V DC; V_{IH} (max.) = V_{DD} + 2.0V AC (pulse width ≤ 2 ns). Not 100% tested.

AC TEST CONDITIONS (HIGH SPEED)

Parameter	Unit (2.4V-3.6V)
Input Pulse Level	0.4V to V _{DD} -0.3V
Input Rise and Fall Times	1.5ns
Input and Output Timing and Reference Level (V _{Ref})	V _{DD} /2
Output Load	See Figures 1 and 2

AC TEST LOADS

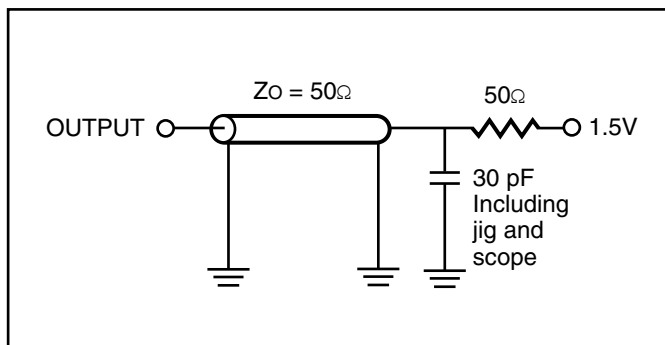

Figure 1.

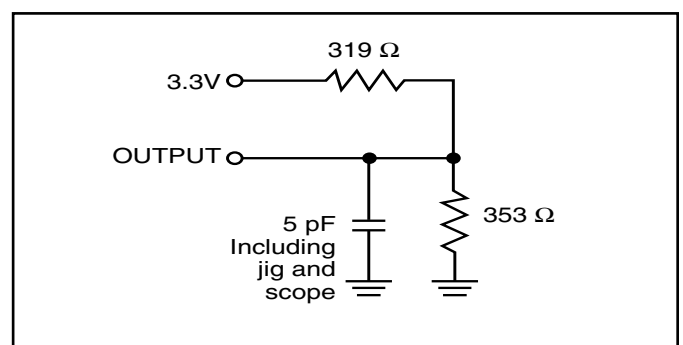

Figure 2.

POWER SUPPLY CHARACTERISTICS⁽¹⁾ (Over Operating Range)

Symbol	Parameter	Test Conditions		-8		-10		-20		Unit
				Min.	Max.	Min.	Max.	Min.	Max.	
I _{CC}	V _{DD} Dynamic Operating Supply Current	V _{DD} = Max., I _{OUT} = 0 mA, f = f _{MAX}	Com.	—	50	—	45	—	35	mA
			Ind.	—	60	—	55	—	45	
			Auto.	—	—	—	65	—	60	
			typ. ⁽²⁾			15				
I _{CC1}	Operating Supply Current	V _{DD} = Max., I _{OUT} = 0 mA, f = 0	Com.	—	20	—	20	—	20	mA
			Ind.	—	25	—	25	—	25	
			Auto.	—	—	—	50	—	50	
I _{SB1}	TTL Standby Current (TTL Inputs)	V _{DD} = Max., V _{IN} = V _{IH} or V _{IL} $\overline{CE} \geq V_{IH}$, f = 0	Com.	—	20	—	20	—	20	mA
			Ind.	—	25	—	25	—	25	
			Auto.	—	—	—	45	—	45	
I _{SB2}	CMOS Standby Current (CMOS Inputs)	V _{DD} = Max., $\overline{CE} \geq V_{DD} - 0.2V$, V _{IN} ≥ V _{DD} - 0.2V, or V _{IN} ≤ 0.2V, f = 0	Com.	—	10	—	10	—	10	mA
			Ind.	—	15	—	15	—	15	
			Auto.	—	—	—	35	—	35	
			typ. ⁽²⁾			2				

Note:

1. At f = f_{MAX}, address and data inputs are cycling at the maximum frequency, f = 0 means no input lines change.
2. Typical values are measured at V_{DD} = 3.0V, T_A = 25°C and not 100% tested.

READ CYCLE SWITCHING CHARACTERISTICS⁽¹⁾ (Over Operating Range)

Symbol	Parameter	-8		-10		Unit
		Min.	Max.	Min.	Max.	
t _{RC}	Read Cycle Time	8	—	10	—	ns
t _{AA}	Address Access Time	—	8	—	10	ns
t _{OHA}	Output Hold Time	2.5	—	2.5	—	ns
t _{ACE}	\overline{CE} Access Time	—	8	—	10	ns
t _{DOE}	\overline{OE} Access Time	—	5.5	—	6.5	ns
t _{HZOE⁽²⁾}	\overline{OE} to High-Z Output	—	3	—	4	ns
t _{LZOE⁽²⁾}	\overline{OE} to Low-Z Output	0	—	0	—	ns
t _{HZCE⁽²⁾}	\overline{CE} to High-Z Output	0	3	0	4	ns
t _{LZCE⁽²⁾}	\overline{CE} to Low-Z Output	3	—	3	—	ns
t _{PU}	Power Up Time	0	—	0	—	ns
t _{PD}	Power Down Time	—	8	—	10	ns

Notes:

1. Test conditions and output loading conditions are specified in the AC Test Conditions and AC Test Loads (Figure 1).
2. Tested with the load in Figure 2. Transition is measured ± 500 mV from steady-state voltage.

READ CYCLE SWITCHING CHARACTERISTICS⁽¹⁾ (Over Operating Range)

Symbol	Parameter	-20 ns		Unit
		Min.	Max.	
t _{RC}	Read Cycle Time	20	—	ns
t _{AA}	Address Access Time	—	20	ns
t _{OHA}	Output Hold Time	2.5	—	ns
t _{ACE}	\overline{CE} Access Time	—	20	ns
t _{DOE}	\overline{OE} Access Time	—	8	ns
t _{HZOE⁽²⁾}	\overline{OE} to High-Z Output	0	8	ns
t _{LZOE⁽²⁾}	\overline{OE} to Low-Z Output	0	—	ns
t _{HZCE⁽²⁾}	\overline{CE} to High-Z Output	0	8	ns
t _{LZCE⁽²⁾}	\overline{CE} to Low-Z Output	3	—	ns
t _{PU}	Power Up Time	0	—	ns
t _{PD}	Power Down Time	—	20	ns

Notes:

1. Test conditions and output loading conditions are specified in the AC Test Conditions and AC Test Loads (Figure 1).
2. Tested with the load in Figure 2. Transition is measured ± 500 mV from steady-state voltage. Not 100% tested.
3. Not 100% tested.

AC WAVEFORMS

READ CYCLE NO. 1^(1,2) (Address Controlled) ($\overline{CE} = \overline{OE} = V_{IL}$)

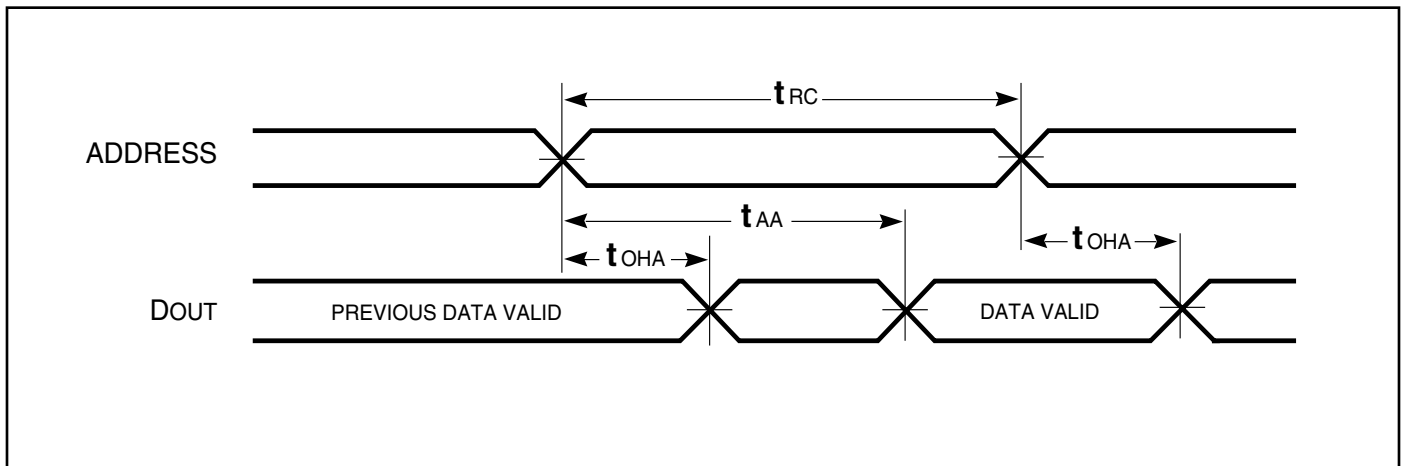

READ CYCLE NO. 2^(1,3) (\overline{CE} and \overline{OE} Controlled)

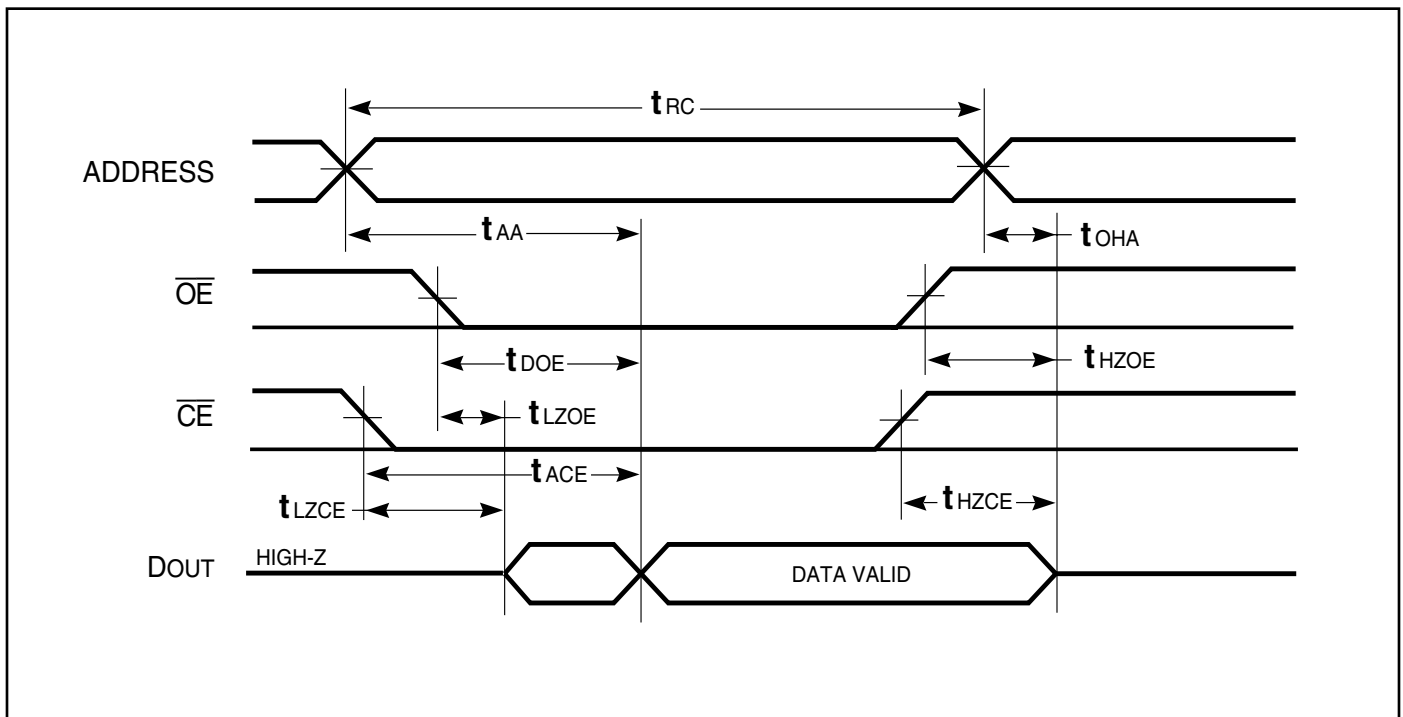

Notes:

1. \overline{WE} is HIGH for a Read Cycle.
2. The device is continuously selected. $\overline{OE}, \overline{CE} = V_{IL}$.
3. Address is valid prior to or coincident with \overline{CE} LOW transitions.

WRITE CYCLE SWITCHING CHARACTERISTICS^(1,3) (Over Operating Range)

Symbol	Parameter	-8		-10		Unit
		Min.	Max.	Min.	Max.	
t _{WC}	Write Cycle Time	8	—	10	—	ns
t _{SCE}	\overline{CE} to Write End	6.5	—	8	—	ns
t _{AW}	Address Setup Time to Write End	6.5	—	8	—	ns
t _{HA}	Address Hold from Write End	0	—	0	—	ns
t _{SA}	Address Setup Time	0	—	0	—	ns
t _{PWE1}	\overline{WE} Pulse Width (\overline{OE} = HIGH)	6.5	—	8	—	ns
t _{PWE2}	\overline{WE} Pulse Width (\overline{OE} = LOW)	8.0	—	10	—	ns
t _{SD}	Data Setup to Write End	5	—	6	—	ns
t _{HD}	Data Hold from Write End	0	—	0	—	ns
t _{HZWE⁽²⁾}	\overline{WE} LOW to High-Z Output	—	3.5	—	5	ns
t _{LZWE⁽²⁾}	\overline{WE} HIGH to Low-Z Output	2	—	2	—	ns

Notes:

1. Test conditions and output loading conditions are specified in the AC Test Conditions and AC Test Loads (Figure 1).
2. Tested with the load in Figure 2. Transition is measured ± 500 mV from steady-state voltage. Not 100% tested.
3. The internal write time is defined by the overlap of \overline{CE} LOW and \overline{WE} LOW. All signals must be in valid states to initiate a Write, but any one can go inactive to terminate the Write. The Data Input Setup and Hold timing are referenced to the rising or falling edge of the signal that terminates the write. Shaded area product in development

WRITE CYCLE SWITCHING CHARACTERISTICS^(1,2) (Over Operating Range)

Symbol	Parameter	-20 ns		Unit
		Min.	Max.	
t _{WC}	Write Cycle Time	20	—	ns
t _{SCE}	\overline{CE} to Write End	12	—	ns
t _{AW}	Address Setup Time to Write End	12	—	ns
t _{HA}	Address Hold from Write End	0	—	ns
t _{SA}	Address Setup Time	0	—	ns
t _{PWE1}	\overline{WE} Pulse Width (\overline{OE} = HIGH)	12	—	ns
t _{PWE2}	\overline{WE} Pulse Width (\overline{OE} = LOW)	17	—	ns
t _{SD}	Data Setup to Write End	9	—	ns
t _{HD}	Data Hold from Write End	0	—	ns
t _{HZWE⁽²⁾}	\overline{WE} LOW to High-Z Output	—	9	ns
t _{LZWE⁽²⁾}	\overline{WE} HIGH to Low-Z Output	3	—	ns

Notes:

1. Test conditions and output loading conditions are specified in the AC Test Conditions and AC Test Loads (Figure 1).
2. Tested with the load in Figure 2. Transition is measured ± 500 mV from steady-state voltage. Not 100% tested.
3. The internal write time is defined by the overlap of \overline{CE} LOW and \overline{WE} LOW. All signals must be in valid states to initiate a Write, but any one can go inactive to terminate the Write. The Data Input Setup and Hold timing are referenced to the rising or falling edge of the signal that terminates the write.

AC WAVEFORMS

WRITE CYCLE NO. 1^(1,2) (\overline{CE} Controlled, \overline{OE} = HIGH or LOW)

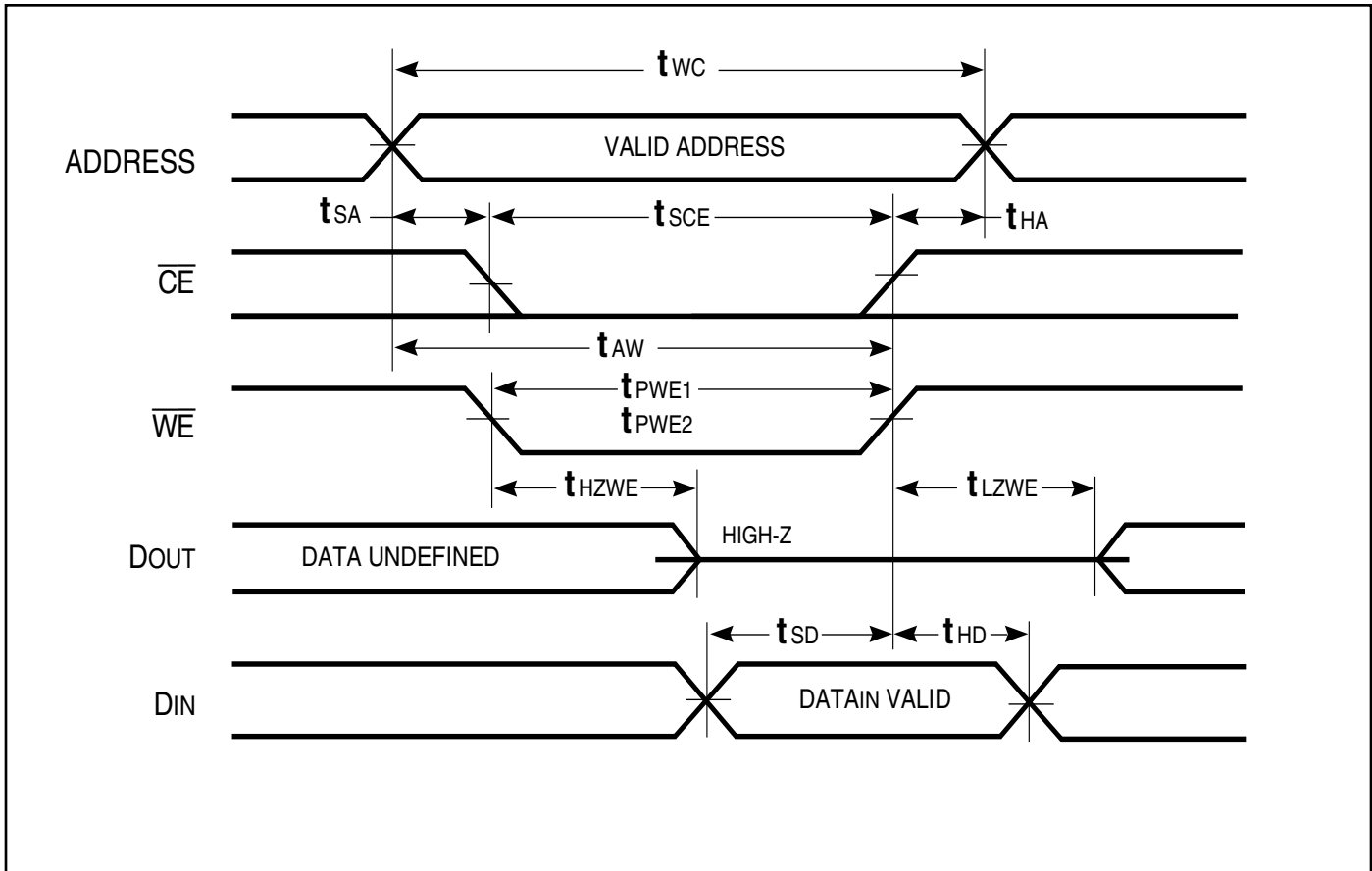

AC WAVEFORMS

WRITE CYCLE NO. 2^(1,2) (\overline{WE} Controlled: \overline{OE} is HIGH During Write Cycle)

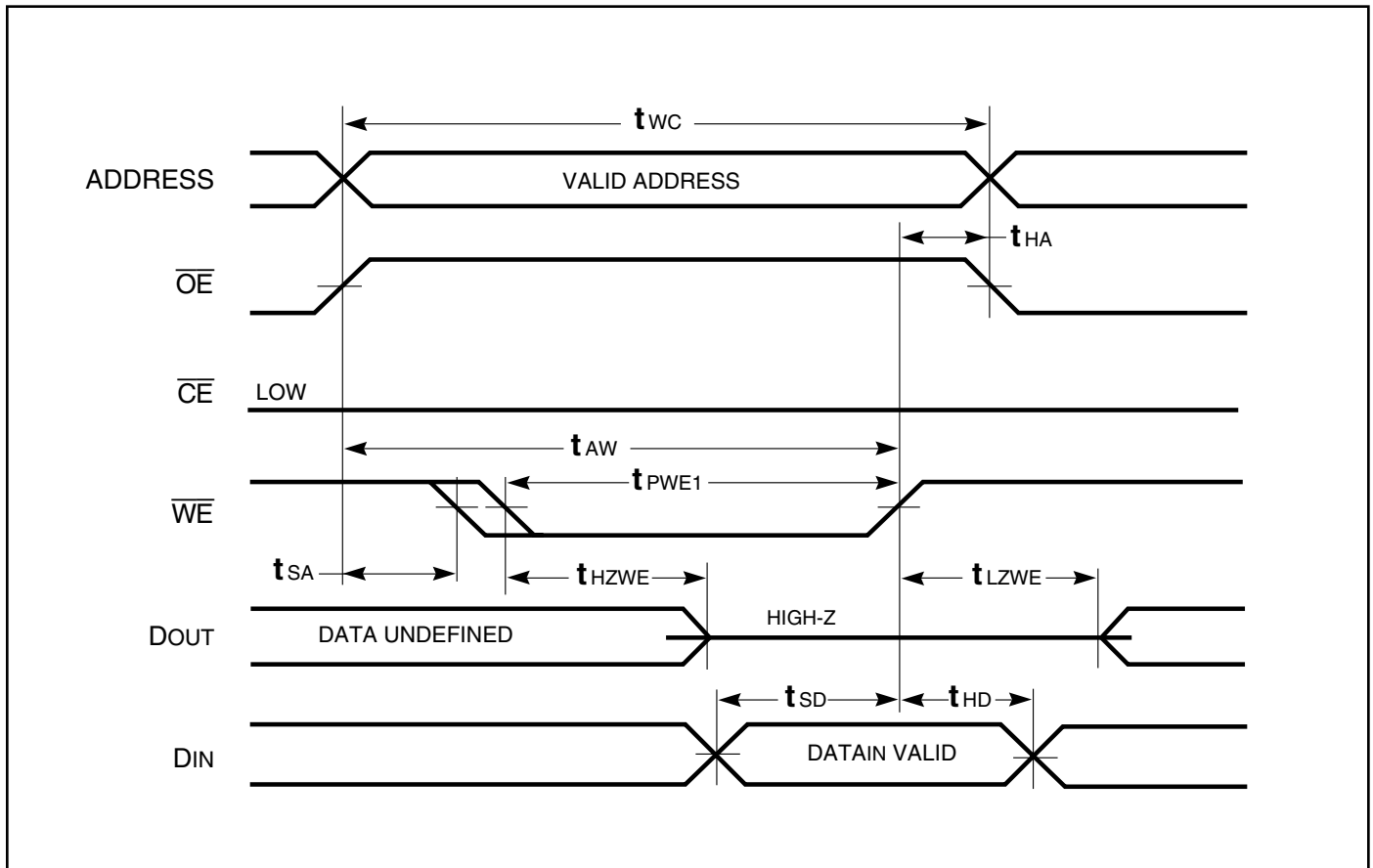

Notes:

1. The internal write time is defined by the overlap of \overline{CE} LOW and \overline{WE} LOW. All signals must be in valid states to initiate a Write, but any one can go inactive to terminate the Write. The Data Input Setup and Hold timing are referenced to the rising or falling edge of the signal that terminates the Write.
2. I/O will assume the High-Z state if $\overline{OE} > V_{IH}$.

AC WAVEFORMS

WRITE CYCLE NO. 3 (\overline{WE} Controlled: \overline{OE} is LOW During Write Cycle)

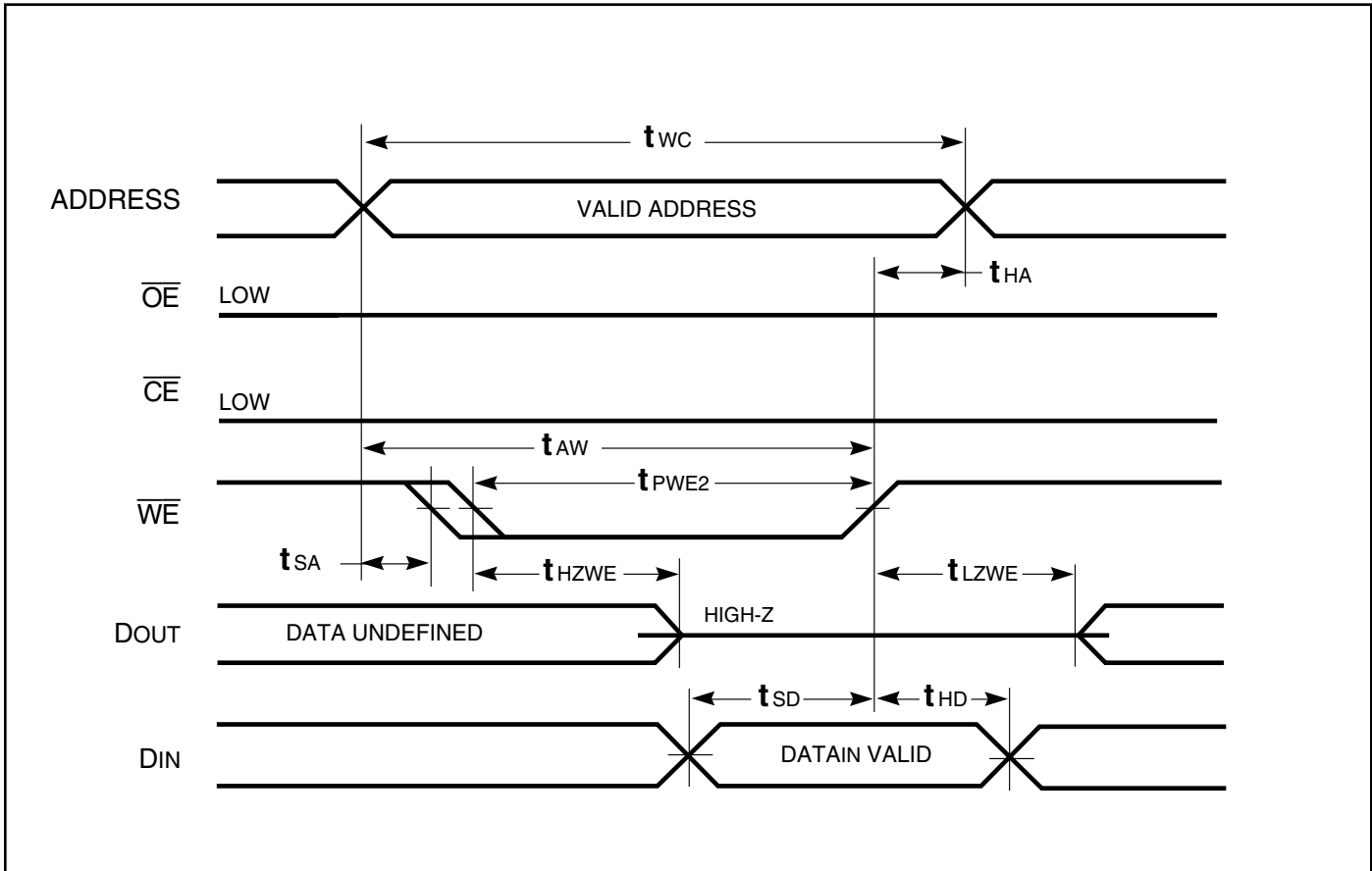

DATA RETENTION SWITCHING CHARACTERISTICS (2.4V-3.6V)

Symbol	Parameter	Test Condition	Options	Min.	Typ. ⁽¹⁾	Max.	Unit
V _{DR}	V _{DD} for Data Retention	See Data Retention Waveform		2.0	—	3.6	V
I _{DR}	Data Retention Current	V _{DD} = 2.0V, $\overline{CE} \geq V_{DD} - 0.2V$	Com. Ind. Auto.	—	2	10 15 35	mA
t _{SDR}	Data Retention Setup Time	See Data Retention Waveform		0	—	—	ns
t _{RDR}	Recovery Time	See Data Retention Waveform		t _{RC}	—	—	ns

Note 1: Typical values are measured at V_{DD} = V_{DR}(min), T_A = 25°C and not 100% tested.

DATA RETENTION WAVEFORM (\overline{CE} Controlled)

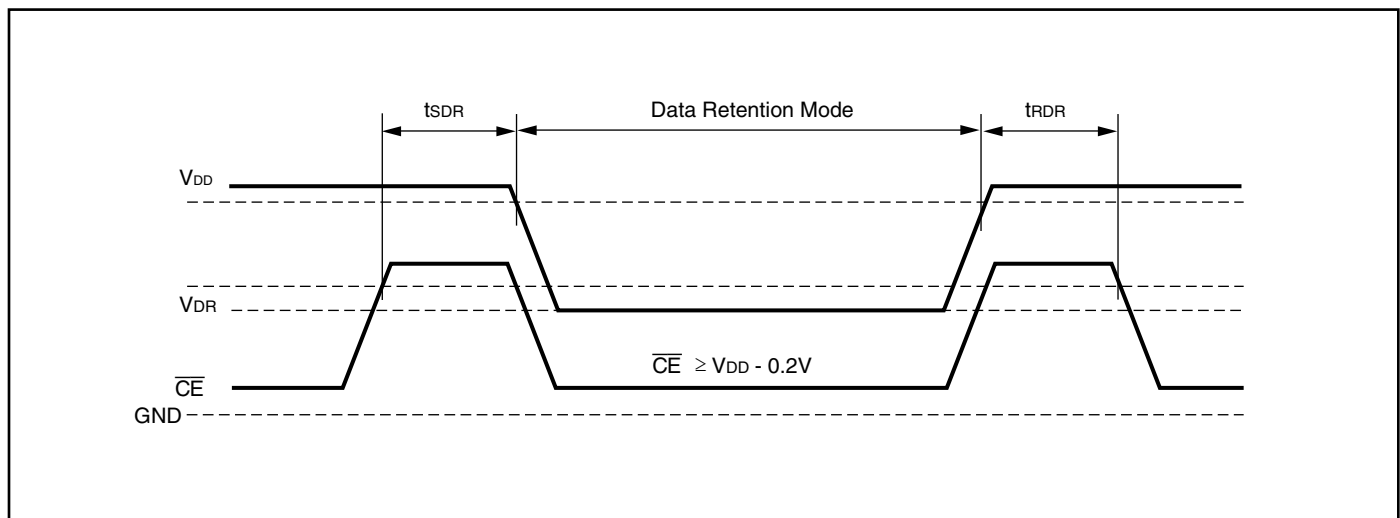

ORDERING INFORMATION

Industrial Range: -40°C to +85°C

Voltage Range: 2.4V to 3.6V

Speed (ns)	Order Part No.	Package
8	IS61WV10248EDBLL-8BLI	48 mini BGA (6mm x 8mm), Lead-free
	IS61WV10248EDBLL-8TLI	TSOP (Type II), Lead-free
10	IS61WV10248EDBLL-10BI	48 mini BGA (6mm x 8mm)
	IS61WV10248EDBLL-10BLI	48 mini BGA (6mm x 8mm), Lead-free
	IS61WV10248EDBLL-10TI	TSOP (Type II)
	IS61WV10248EDBLL-10TLI	TSOP (Type II), Lead-free

Automotive Range: -40°C to +125°C

Voltage Range: 2.4V to 3.6V

Speed (ns)	Order Part No.	Package
10	IS64WV10248EDBLL-10BA3	48 mini BGA (6mm x 8mm)
	IS64WV10248EDBLL-10BLA3	48 mini BGA (6mm x 8mm), Lead-free
	IS64WV10248EDBLL-10CTA3	TSOP (Type II), Copper Leadframe
	IS64WV10248EDBLL-10CTLA3	TSOP (Type II), Lead-free, Copper Leadframe

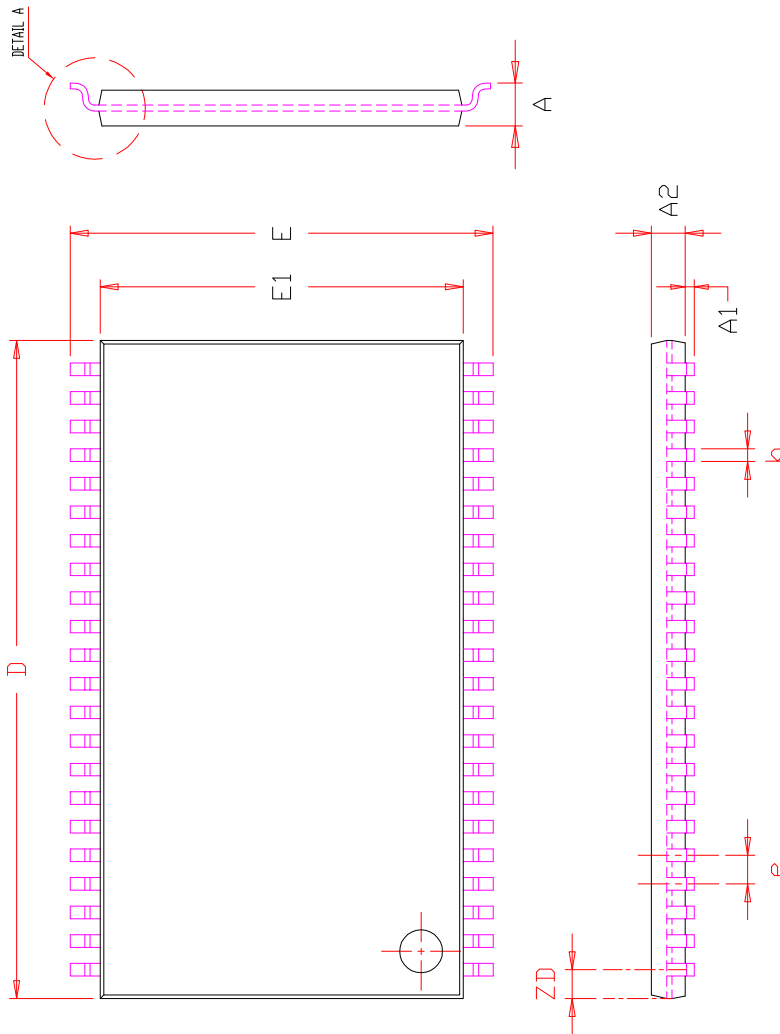

SYMBOL	DIMENSION IN MM			DIMENSION IN INCH		
	MIN.	NOM.	MAX.	MIN.	NOM.	MAX.
A	1.00		1.20	0.039		0.047
A1	0.05		0.15	0.002		0.006
A2	0.95	1.00	1.05	0.037	0.039	0.041
b	0.30		0.45	0.012		0.018
D	18.28	18.41	18.54	0.720	0.725	0.730
E	11.56	11.76	11.96	0.455	0.463	0.471
E1	10.03	10.16	10.29	0.395	0.400	0.405
e		0.80 BSC.			0.031 BSC.	
L	0.40		0.69	0.016		0.027
L1		0.25 BSC.			0.010 BSC.	
ZD		0.805 REF.			0.032 REF.	
⊕	0		8°	0		8°

NOTE :

1. CONTROLLING DIMENSION : MM
2. DIMENSION D AND E1 DO NOT INCLUDE MOLD PROTRUSION.
3. DIMENSION b DOES NOT INCLUDE DAMBAR PROTRUSION/INTRUSION.

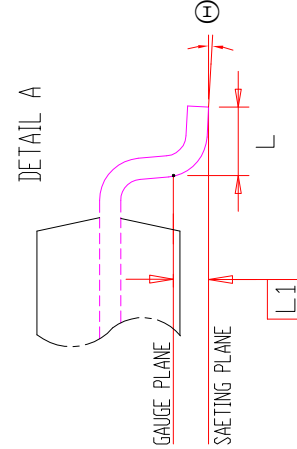

	TITLE	44L 400mil TSOP-2 Package Outline	REV.	F	DATE	06/04/2008

Looking for pricing, stock, or lifecycle information?

Click below to explore more details on WIN SOURCE:

- ⊖ [View IS61WV10248EDBLL-10TLI on WIN SOURCE](#)
- ⊖ [ISSI, Integrated Silicon Solution Inc Information](#)

Optimize Your Supply Chain with WIN SOURCE Solutions

- ✓ Global Sourcing Solution
- ✓ Obsolete Management
- ✓ Cost Control Management
- ✓ Shortage Management
- ✓ Alternative Solution
- ✓ Excess Inventory Management