



**THE DATASHEET OF
BA4558N**



Dual operational amplifier

BA4558 / BA4558F / BA4558N

The BA4558, BA4558F, and BA4558N are monolithic ICs with two operational amplifiers featuring low power consumption and internal phase compensation mounted on a single silicon chip. These products offer high speed, a wide band width, and low noise.

Outstanding thermal characteristics and voltage gain band width make these ICs ideal for use in a wide variety of electronic circuits. The BA4558 comes in an 8-pin DIP package and is compatible with the 4558 operational amplifier. The BA4558F comes in an 8-pin SOP package, and the BA4558N in an 8-pin SIP package.

●Applications

- Active filters
- Audio amplifiers
- VCOs
- Other electronic circuits

●Features

- 1) Low power dissipation of approximately 50mW (typ.).
- 2) Built-in output short-circuit protection circuit.
- 3) Internal phase compensation.
- 4) No latch-up.
- 5) Wide range of common mode and differential voltage.
- 6) High gain and low noise.

●Block diagram

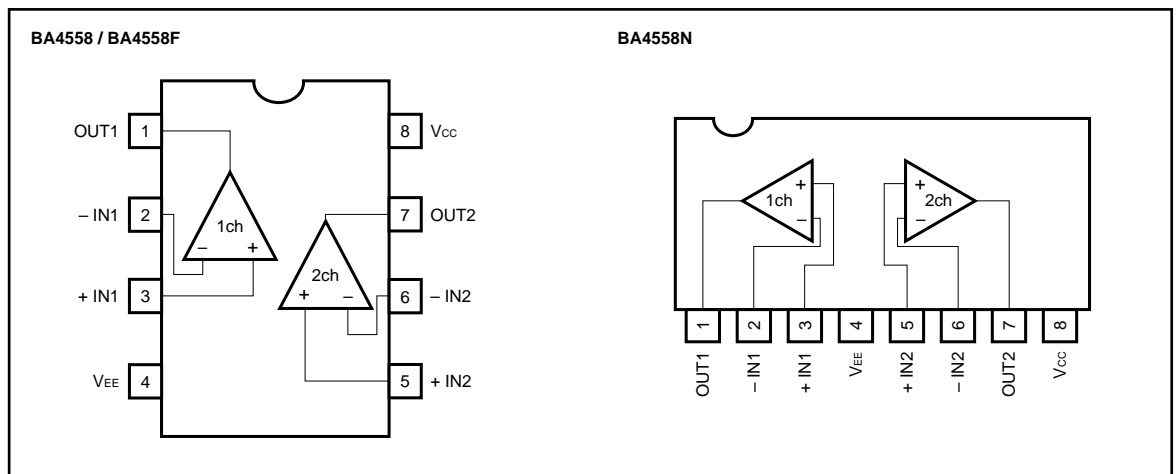

● Internal circuit configuration

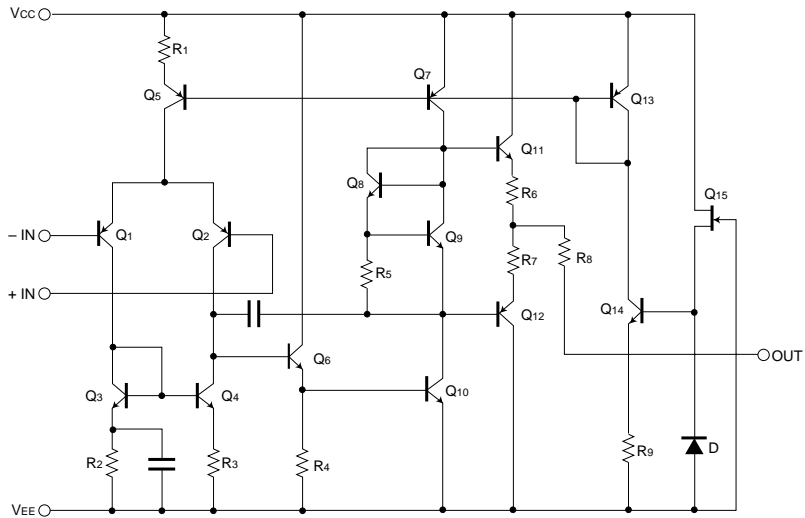

● Absolute maximum ratings (Ta = 25°C)

Parameter	Symbol	Limits			Unit
		BA4558	BA4558F	BA4558N	
Power supply voltage	V _{cc}	± 18	± 18	± 18	V
Power dissipation	P _d	800*	550*	900*	mW
Differential input voltage	V _{ID}	± 30	± 30	± 30	V
Common-mode input voltage	V _I	± 15	± 15	± 15	V
Operating temperature	T _{opr}	- 40 ~ + 85	- 40 ~ + 85	- 40 ~ + 85	°C
Storage temperature	T _{stg}	- 55 ~ + 125	- 55 ~ + 125	- 55 ~ + 125	°C

* Refer to P_d characteristics diagram.

The values for the BA4558F are those when it is mounted on a glass epoxy board (50mm × 50mm × 1.6mm).

●Electrical characteristics (unless otherwise noted, $T_a = 25^\circ\text{C}$, $V_{CC} = +15\text{V}$, $V_{EE} = -15\text{V}$)

Parameter	Symbol	Min.	Typ.	Max.	Unit	Conditions
Input offset voltage	V_{IO}	—	0.5	6.0	mV	$R_s \leq 10\text{k}\Omega$
Input offset current	I_{IO}	—	5	200	nA	
Input bias current	I_B	—	60	500	nA	
High-amplitude voltage gain	A_v	86	100	—	dB	$R_L \cong 2\text{k}\Omega$, $V_O = \pm 10\text{V}$
Common-mode input voltage	V_{ICM}	± 12	± 14	—	V	
Maximum output voltage	V_{OH}	± 12	± 14	—	V	$R_L \cong 10\text{k}\Omega$
Minimum output voltage	V_{OL}	± 10	± 13	—	V	$R_L \cong 2\text{k}\Omega$
Common-mode rejection ratio	CMRR	70	90	—	dB	$R_s \leq 10\text{k}\Omega$
Power supply voltage rejection ratio	PSRR	—	30	150	$\mu\text{V}/\text{V}$	$R_s \leq 10\text{k}\Omega$
Slew rate	S.R.	—	1.0	—	$\text{V}/\mu\text{s}$	$A_v = 1$, $R_L \cong 2\text{k}\Omega$
Channel separation	CS	—	105	—	dB	$f = 1\text{kHz}$

●Electrical characteristic curves

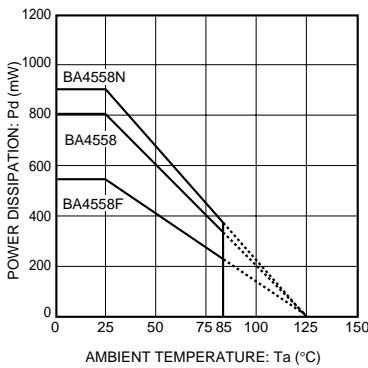

Fig.1 Power dissipation vs. ambient temperature

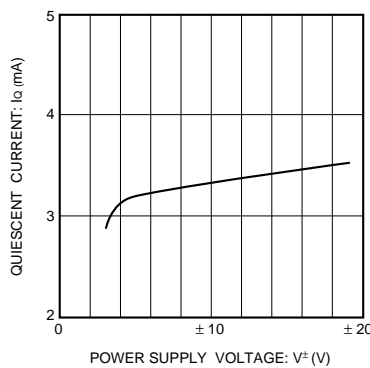

Fig.2 Quiescent current vs. power supply voltage

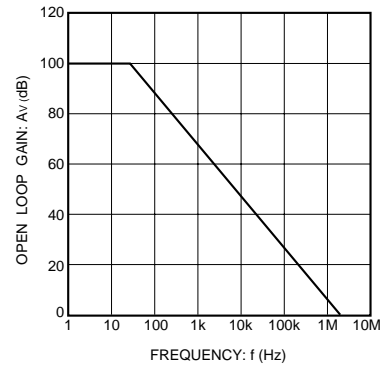

Fig.3 Open loop voltage gain vs. frequency

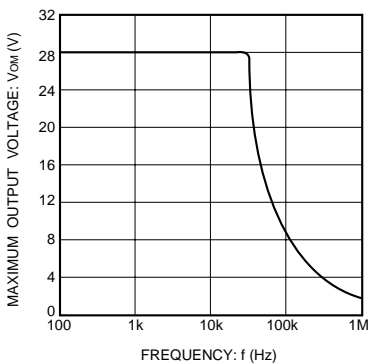

Fig.4 Maximum output voltage vs. frequency

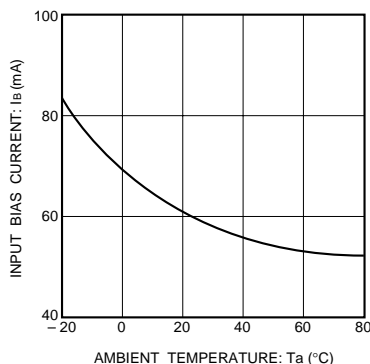

Fig.5 Input bias current vs. ambient temperature

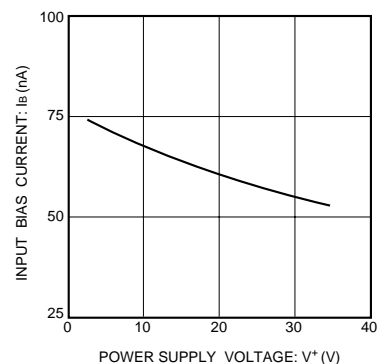

Fig.6 Input bias current vs. power supply voltage

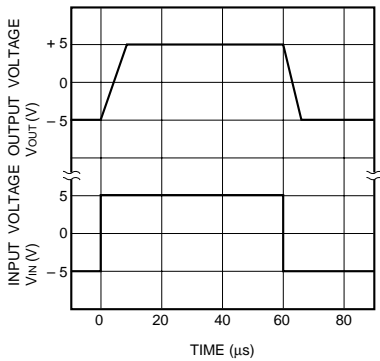

Fig.7 Output response characteristics

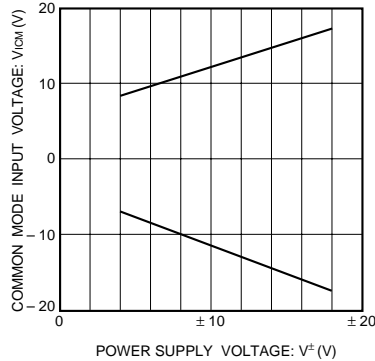

Fig.8 Common mode input voltage vs. power supply voltage

● Operation notes

(1) Unused circuit connections

If there are any circuits which are not being used, we recommend making connections as shown in Figure 9, with the non-inverted input pin connected to the potential within the in-phase input voltage range (V_{icm}).

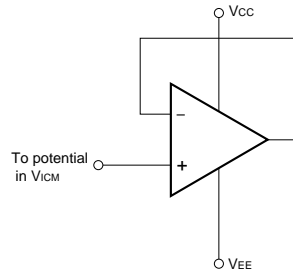
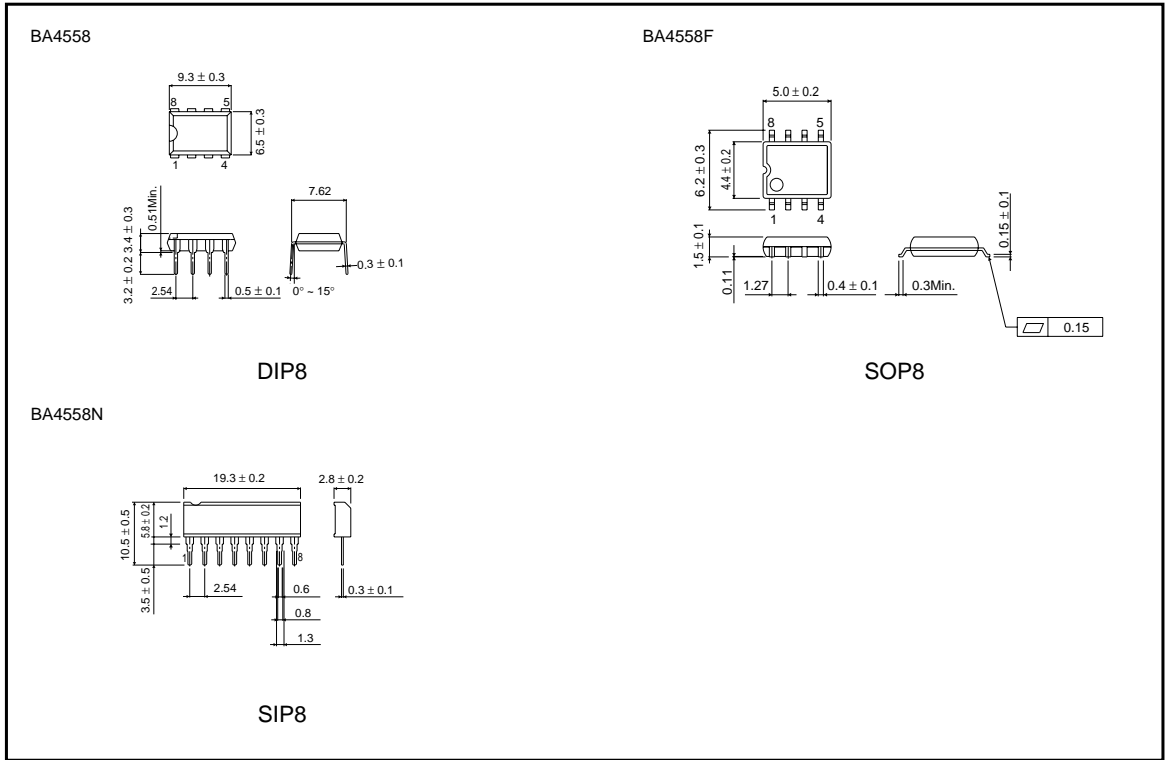



Fig.9 Unused circuit connections

● External dimensions (Units: mm)



Looking for pricing, stock, or lifecycle information?

Click below to explore more details on WIN SOURCE:

-  [View BA4558N on WIN SOURCE](#)
-  [Rohm Semiconductor Information](#)

Optimize Your Supply Chain with WIN SOURCE Solutions

-  Global Sourcing Solution
-  Obsolete Management
-  Cost Control Management
-  Shortage Management
-  Alternative Solution
-  Excess Inventory Management