

Operational Amplifiers Series



Low Noise Operational Amplifiers

BA4510xxx

● **General Description**

BA4510 is dual operational amplifier with high gain. It has good performance of input referred noise voltage ($6\text{ nV}/\sqrt{\text{Hz}}$) and total harmonic distortion (0.007%). These are suitable for Audio applications.

● **Features**

- High voltage gain
- Low input referred noise voltage
- Low distortion
- Wide operating supply voltage

● **Application**

- Audio application
- Consumer electronics

● **Packages**

- SOP8
- SSOP-B8
- TSSOP-B8
- MSOP8

W(Typ.) x D(Typ.) x H(Max.)
5.00mm x 6.20mm x 1.71mm
3.00mm x 6.40mm x 1.35mm
3.00mm x 6.40mm x 1.20mm
2.90mm x 4.00mm x 0.90mm

● **Key Specification**

- Wide Operating Supply Voltage (split supply) : $\pm 1.0\text{V}$ to $\pm 3.5\text{V}$
- Wide Temperature Range: -20°C to $+75^\circ\text{C}$
- High Slew Rate: $5\text{V}/\mu\text{s}$ (Typ.)
- Total Harmonic Distortion: 0.007% (Typ.)
- Input Referred Noise Voltage: $6\text{ nV}/\sqrt{\text{Hz}}$ (Typ.)

● **Block Diagrams**

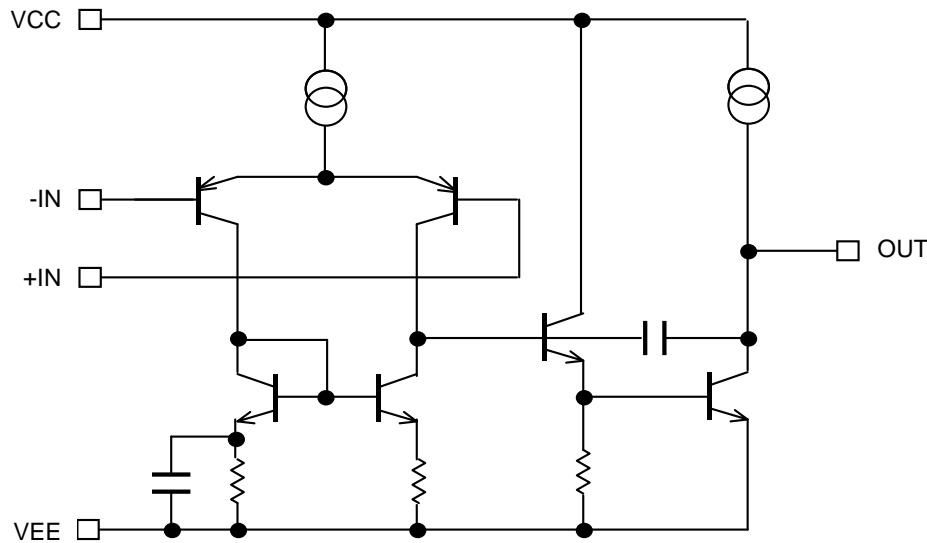
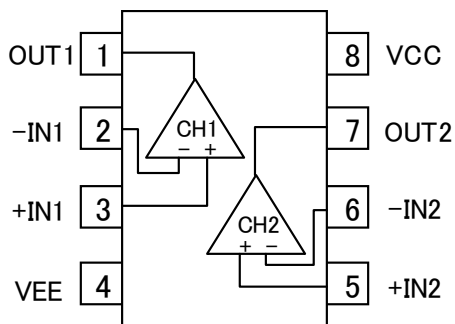

Figure 1. Simplified schematic

○Product structure : Silicon monolithic integrated circuit ○This product is not designed protection against radioactive rays.

●Pin Configuration(TOP VIEW)

SOP8, SSOP-B8, TSSOP-B8, MSOP8



Pin No.	Symbol
1	OUT1
2	-IN1
3	+IN1
4	VEE
5	+IN2
6	-IN2
7	OUT2
8	VCC

Package			
SOP8	SSOP-B8	TSSOP-B8	MSOP8
BA4510F	BA4510FV	BA4510FVT	BA4510FVM

●Ordering Information

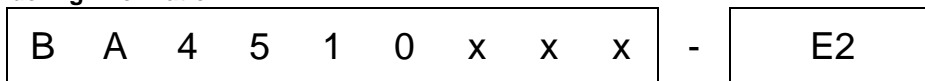

Part Number
BA4510xxx

Package
F : SOP8
FV : SSOP-B8
FVT : TSSOP-B8
FVM : MSOP8

Packaging and forming specification
E2: Embossed tape and reel
(SOP8/SSOP-B8/TSSOP-B8)
TR: Embossed tape and reel
(MSOP8)

●Line-up

Topr	Operating Supply Voltage (split supply)	Supply Current (Typ.)	Slew Rate (Typ.)	Package		Orderable Part Number
-20°C to +75°C	±1.0V to ±3.5V	5mA	5V/μs	SOP8	Reel of 2500	BA4510F-E2
				SSOP-B8	Reel of 2500	BA4510FV-E2
				TSSOP-B8	Reel of 2500	BA4510FVT-E2
				MSOP8	Reel of 3000	BA4510FVM-TR

● Absolute Maximum Ratings (Ta=25°C)

OBA4510

Parameter	Symbol	Ratings	Unit	
Supply Voltage	VCC-VEE	+10	V	
Power dissipation	Pd	SOP8	620 ^{*1,5}	mW
		SSOP-B8	550 ^{*2,5}	
		TSSOP-B8	500 ^{*3,5}	
		MSOP8	470 ^{*4,5}	
Differential Input Voltage ^{*6}	Vid	VCC-VEE	V	
Input Common-mode Voltage Range	Vicm	VEE to VCC	V	
Operating Supply Voltage	Vopr	2 to 7(±1 to ±3.5)	V	
Operating Temperature	Topr	-20 to +75	°C	
Storage Temperature	Tstg	-40 to 125	°C	
Maximum Junction Temperature	Tjmax	+125	°C	

Note: Absolute maximum rating item indicates the condition which must not be exceeded.

Application of voltage in excess of absolute maximum rating or use out absolute maximum rated temperature environment may cause deterioration of characteristics.

*1 To use at temperature above Ta=25°C reduce 6.2mW/°C

*2 To use at temperature above Ta=25°C reduce 5.5mW/°C

*3 To use at temperature above Ta=25°C reduce 5.0mW/°C

*4 To use at temperature above Ta=25°C reduce 4.8mW/°C

*5 Mounted on a FR4 glass epoxy PCB(70mm×70mm×1.6mm).

*6 The voltage difference between inverting input and non-inverting input is the differential input voltage. Then input terminal voltage is set to more than VEE.

● Electrical Characteristics

OBA4510 (Unless otherwise specified VCC=+2.5V, VEE=-2.5V, Ta=25°C)

Parameter	Symbol	Limits			Unit	Condition
		Min.	Typ.	Max.		
Input Offset Voltage ^{*7}	Vio	-	1	6	mV	RS=50Ω
Input Offset Current ^{*7}	Iio	-	2	200	nA	-
Input Bias Current ^{*8}	Ib	-	80	500	nA	-
Supply Current	ICC	2.5	5.0	7.5	mA	RL=∞, All Op-Amps
Maximum Output Voltage(High)	VOH	+2.0	+2.4	-	V	RL=10kΩ
Maximum Output Voltage(Low)	VOL	-	-2.4	-2.0	V	RL=10kΩ
Large Signal Voltage Gain	Av	60	90	-	dB	RL ≥ 10kΩ
Input Common-mode Voltage Range	Vicm	-1.3	-	+1.5	V	-
Common-mode Rejection Ratio	CMRR	60	80	-	dB	-
Power Supply Rejection Ratio	PSRR	60	80	-	dB	RS=50Ω
Slew Rate	SR	-	5.0	-	V/μs	Av=1
Total Harmonic Distortion+ Noise	THD+N	-	0.007	-	%	Av=20dB, RL=10kΩ, VIN=0.05Vrms, f=1kHz DIN-AUDIO
Input Referred Noise Voltage	Vn	-	6	-	nV/√Hz	RS=100Ω, Vi=0V, f=1kHz
		-	0.7	-	μVrms	DIN-AUDIO
Channel Separation	CS	-	-	-	dB	R1=100Ω, f=1kHz

*7 Absolute value

*8 Current direction: Since first input stage is composed with PNP transistor, input bias current flows out of IC.

Description of electrical characteristics

Described here are the terms of electric characteristics used in this datasheet. Items and symbols used are also shown. Note that item name and symbol and their meaning may differ from those on another manufacture's document or general document.

1. Absolute maximum ratings

Absolute maximum rating item indicates the condition which must not be exceeded. Application of voltage in excess of absolute maximum rating or use out of absolute maximum rated temperature environment may cause deterioration of characteristics.

1.1 Power supply voltage (VCC/VEE)

Indicates the maximum voltage that can be applied between the positive power supply terminal and negative power supply terminal without deterioration or destruction of characteristics of internal circuit.

1.2 Differential input voltage (Vid)

Indicates the maximum voltage that can be applied between non-inverting terminal and inverting terminal without deterioration and destruction of characteristics of IC.

1.3 Input common-mode voltage range (Vicm)

Indicates the maximum voltage that can be applied to non-inverting terminal and inverting terminal without deterioration or destruction of characteristics. Input common-mode voltage range of the maximum ratings not assure normal operation of IC. When normal operation of IC is desired, the input common-mode voltage of characteristics item must be followed.

1.4 Power dissipation (Pd)

Indicates the power that can be consumed by specified mounted board at the ambient temperature 25°C(normal temperature). As for package product, Pd is determined by the temperature that can be permitted by IC chip in the package (maximum junction temperature) and thermal resistance of the package.

2. Electrical characteristics item

2.1 Input offset voltage (Vio)

Indicates the voltage difference between non-inverting terminal and inverting terminal. It can be translated into the input voltage difference required for setting the output voltage at 0 V.

2.2 Input offset current (Iio)

Indicates the difference of input bias current between non-inverting terminal and inverting terminal.

2.3 Input bias current (Ib)

Indicates the current that flows into or out of the input terminal. It is defined by the average of input bias current at non-inverting terminal and input bias current at inverting terminal.

2.4 Input common-mode voltage range(Vicm)

Indicates the input voltage range where IC operates normally.

2.5 Large signal voltage gain (Av)

Indicates the amplifying rate (gain) of output voltage against the voltage difference between non-inverting terminal and inverting terminal. It is normally the amplifying rate (gain) with reference to DC voltage.

$$A_v = (\text{Output voltage fluctuation}) / (\text{Input offset fluctuation})$$

2.6 Circuit current (ICC)

Indicates the IC current that flows under specified conditions and no-load steady status.

2.7 Maximum Output Voltage(High) / Maximum Output Voltage(Low) (VOH/VOL)

Indicates the voltage range that can be output by the IC under specified load condition. It is typically divided into maximum output voltage High and low. Maximum output voltage high indicates the upper limit of output voltage. Maximum output voltage low indicates the lower limit.

2.8 Common-mode rejection ratio (CMRR)

Indicates the ratio of fluctuation of input offset voltage when in-phase input voltage is changed. It is normally the fluctuation of DC.

$$CMRR = (\text{Change of Input common-mode voltage}) / (\text{Input offset fluctuation})$$

2.9 Power supply rejection ratio (PSRR)

Indicates the ratio of fluctuation of input offset voltage when supply voltage is changed. It is normally the fluctuation of DC.

$$PSRR = (\text{Change of power supply voltage}) / (\text{Input offset fluctuation})$$

2.10 Slew Rate (SR)

SR is a parameter that shows movement speed of operational amplifier. It indicates rate of variable output voltage as unit time.

2.11 Total harmonic distortion + Noise (THD+N)

Indicates the fluctuation of input offset voltage or that of output voltage with reference to the change of output voltage of driven channel.

2.12 Input referred noise voltage (Vn)

Indicates a noise voltage generated inside the operational amplifier equivalent by ideal voltage source connected in series with input terminal.

2.13 Channel separation (CS)

Indicates the fluctuation of input offset voltage or that of output voltage with reference to the change of output voltage of driven channel.

● Typical Performance Curves

OBA4510

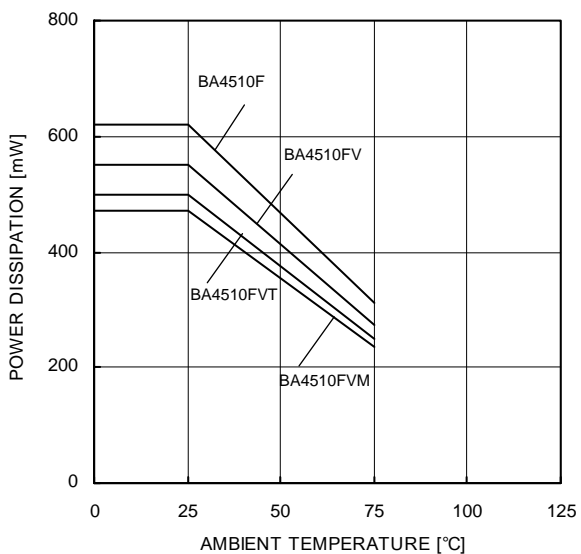

Figure 2.
Derating Curve

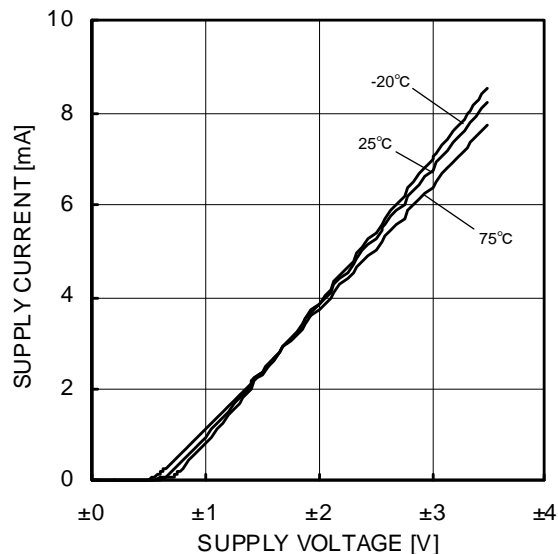

Figure 3.
Supply Current - Supply Voltage

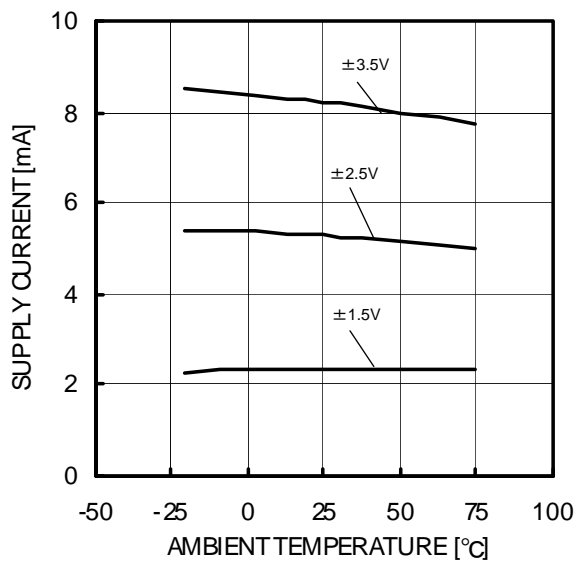

Figure 4.
Supply Current - Ambient Temperature

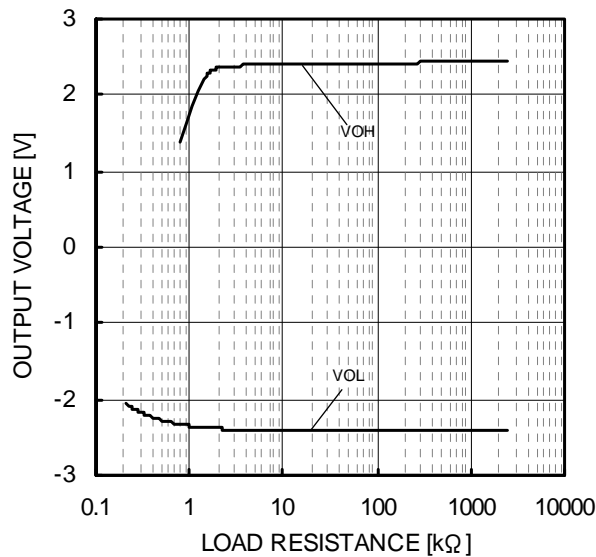

Figure 5.
Maximum Output Voltage Swing
- Load Resistance
(VCC/VEE=2.5V/-2.5V, Ta=25°C)

(*) The above data is measurement value of typical sample, it is not guaranteed.

OBA4510

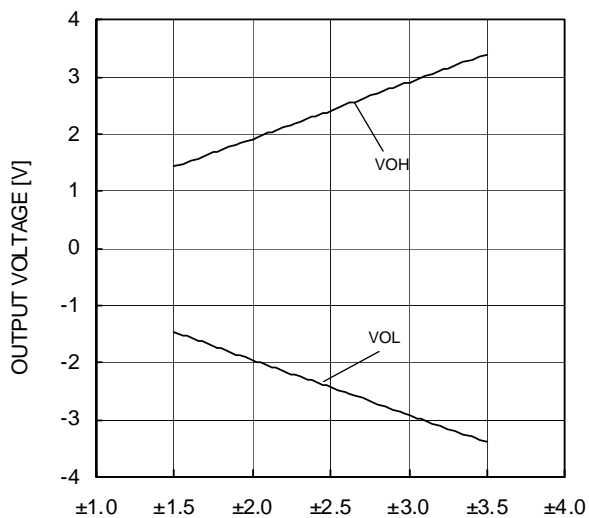

Figure 6.
Maximum Output Voltage
- Supply Voltage
($R_L=10k\Omega$, $T_a=25^\circ C$)

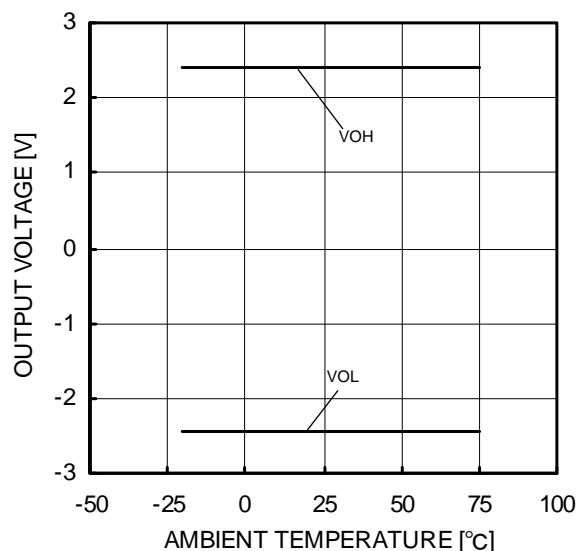

Figure 7.
Maximum Output Voltage
- Ambient Temperature
($V_{CC}/V_{EE}=2.5V/-2.5V$, $R_L=10k\Omega$)

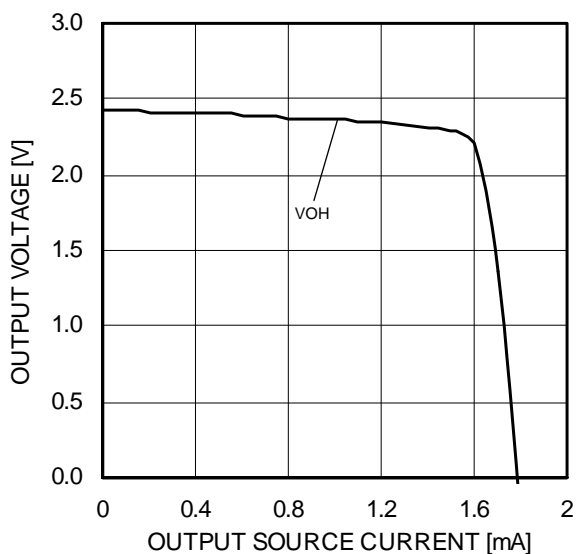

Figure 8.
Maximum Output Voltage
- Output Source Current
($V_{CC}/V_{EE}=2.5V/-2.5V$, $T_a=25^\circ C$)

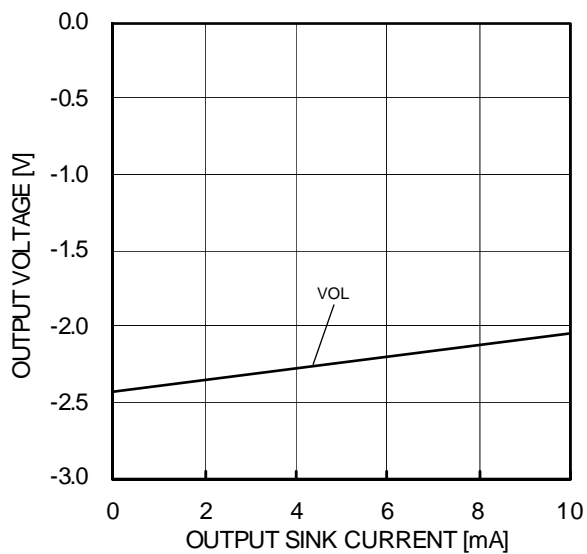

Figure 9.
Maximum Output Voltage
- Output Sink Current
($V_{CC}/V_{EE}=2.5V/-2.5V$, $T_a=25^\circ C$)

(*) The above data is measurement value of typical sample, it is not guaranteed.

OBA4510

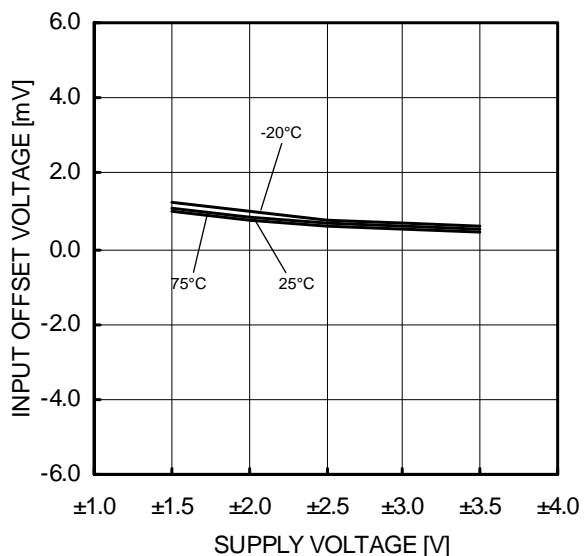

Figure 10.
Input Offset Voltage - Supply Voltage
($V_{icm}=0V$, $V_{out}=0V$)

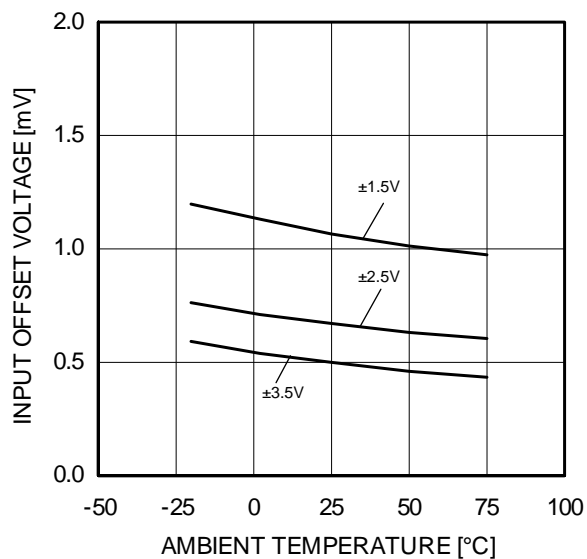

Figure 11.
Input Offset Voltage - Ambient Temperature
($V_{icm}=0V$, $V_{out}=0V$)

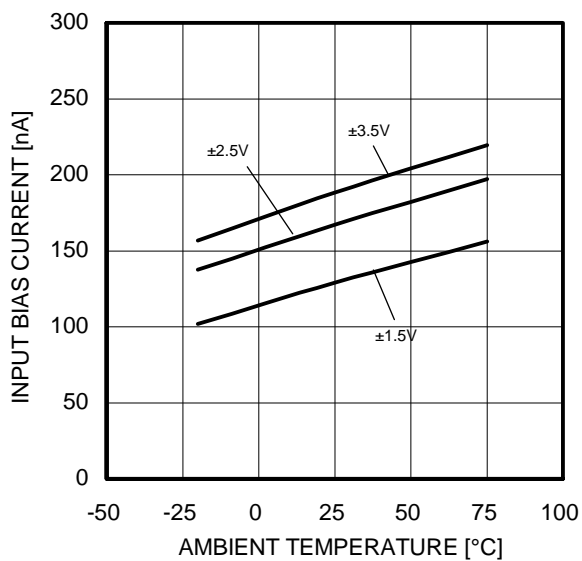

Figure 12.
Input Bias Current - Supply Voltage
($V_{icm}=0V$, $V_{out}=0V$)

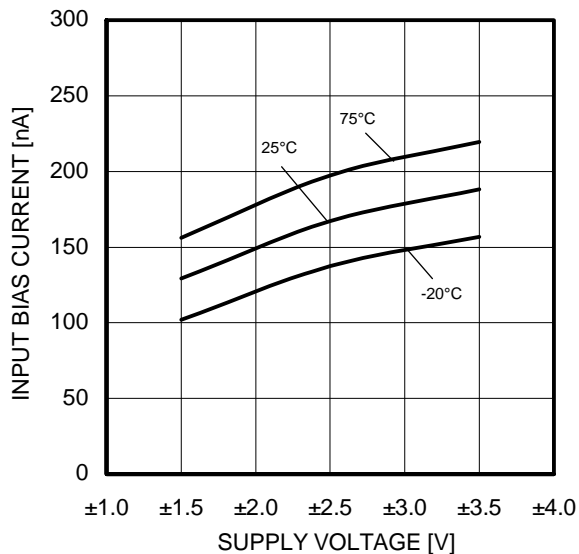

Figure 13.
Input Bias Current - Ambient Temperature
($V_{icm}=0V$, $V_{out}=0V$)

(*) The above data is measurement value of typical sample, it is not guaranteed.

OBA4510

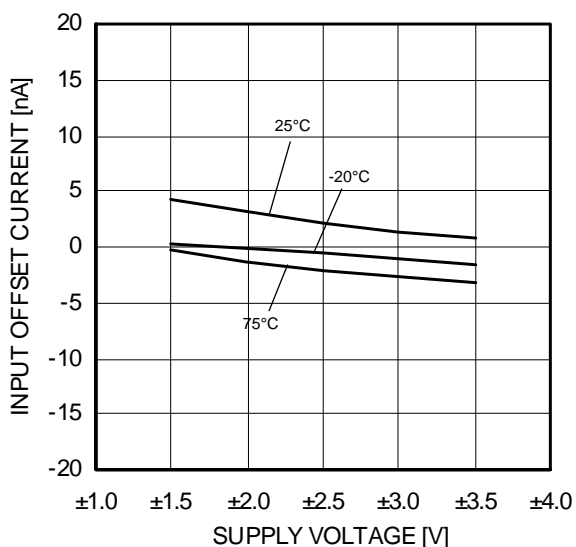

Figure 14.
Input Offset Current - Supply Voltage
(Vicm=0V, Vout=0V)

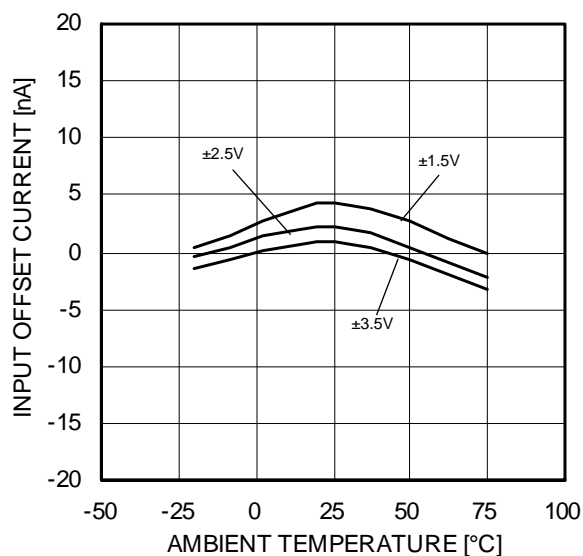

Figure 15.
Input Offset Current - Ambient Temperature
(Vicm=0V, Vout=0V)

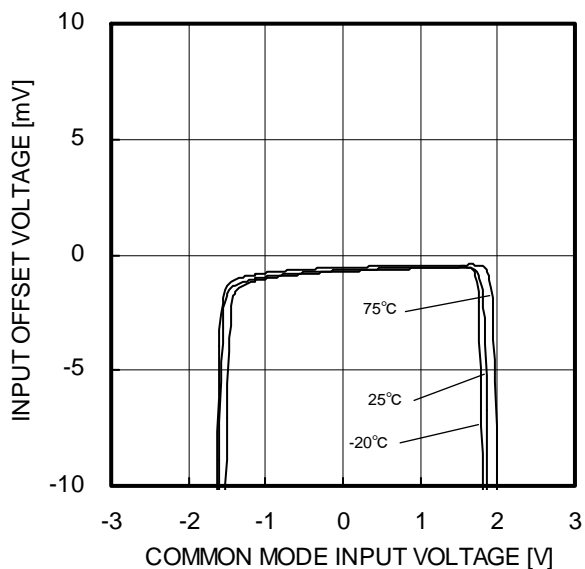

Figure 16.
Input Offset Voltage
- Common Mode Input Voltage
(VCC/VEE=2.5V/-2.5V)

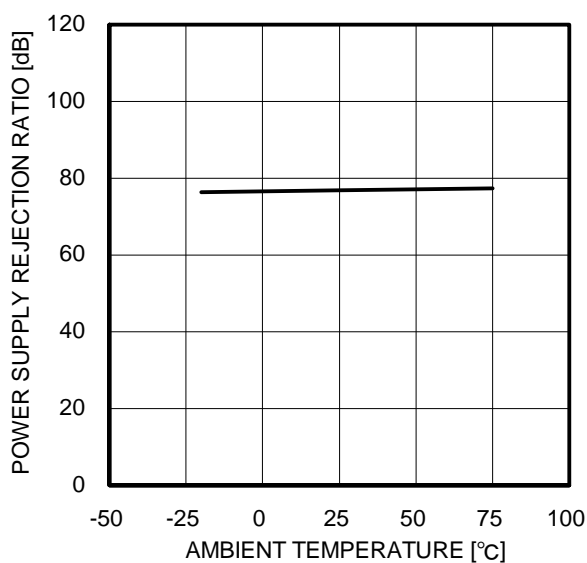

Figure 17.
Large Signal Voltage Gain
- Ambient Temperature

(*) The above data is measurement value of typical sample, it is not guaranteed.

OBA4510

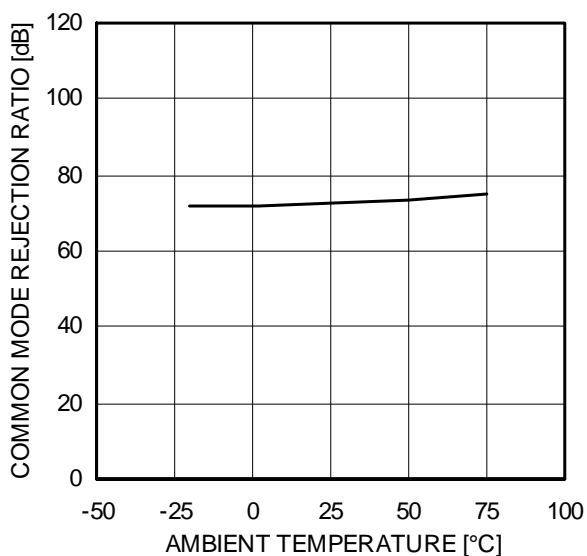

Figure 18.
Common Mode Rejection Ratio
- Ambient Temperature

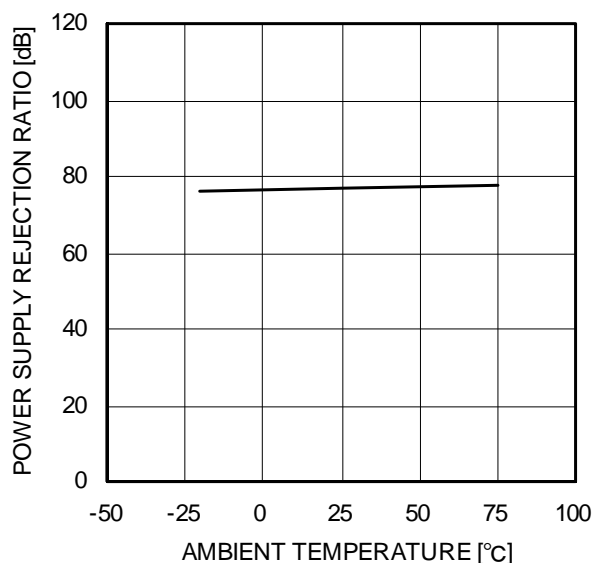

Figure 19.
Power Supply Rejection Ratio
- Ambient Temperature

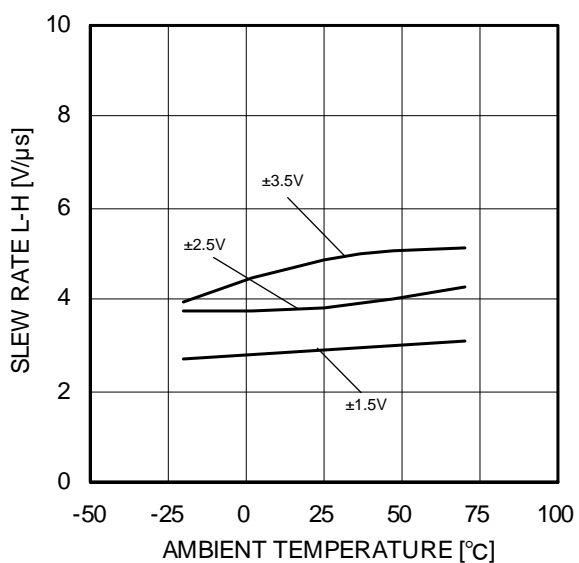

Figure 20.
Slew Rate L-H - Ambient Temperature

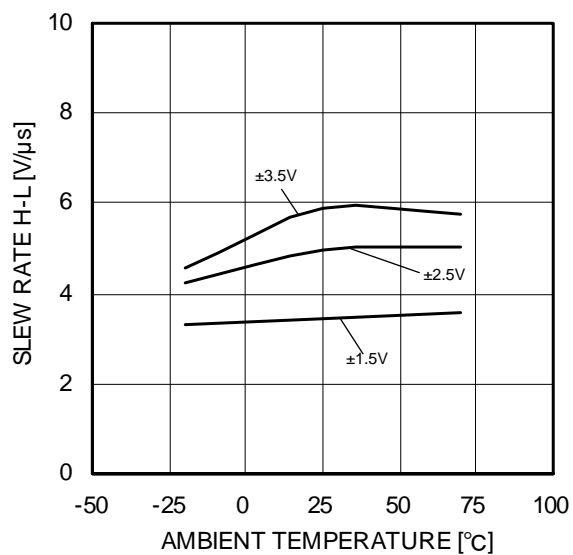

Figure 21.
Slew Rate H-L - Ambient Temperature

(*) The above data is measurement value of typical sample, it is not guaranteed.

OBA4510

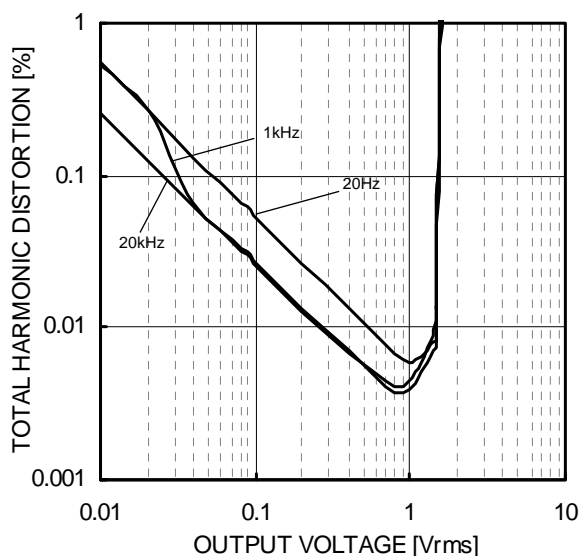

Figure 22.
Total Harmonic Distortion - Output Voltage
(VCC/VEE=2.5V/-2.5V, RL=3kΩ, 80kHz-LPF, Ta=25°C)

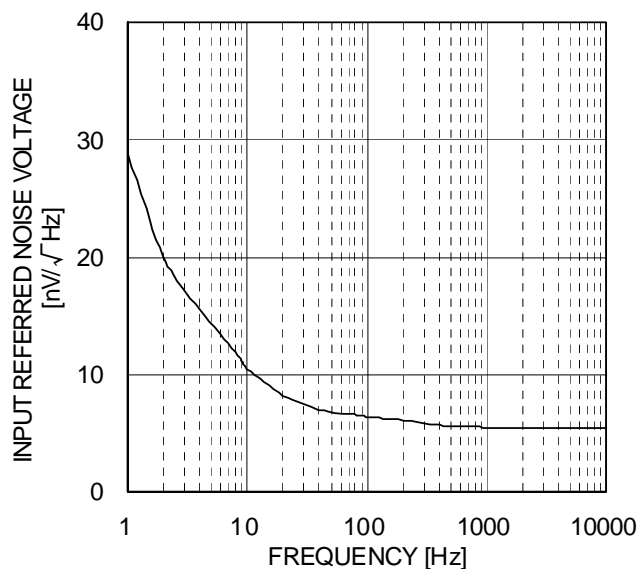

Figure 23.
Equivalent Input Noise Voltage - Frequency
(VCC/VEE=2.5V/-2.5V)

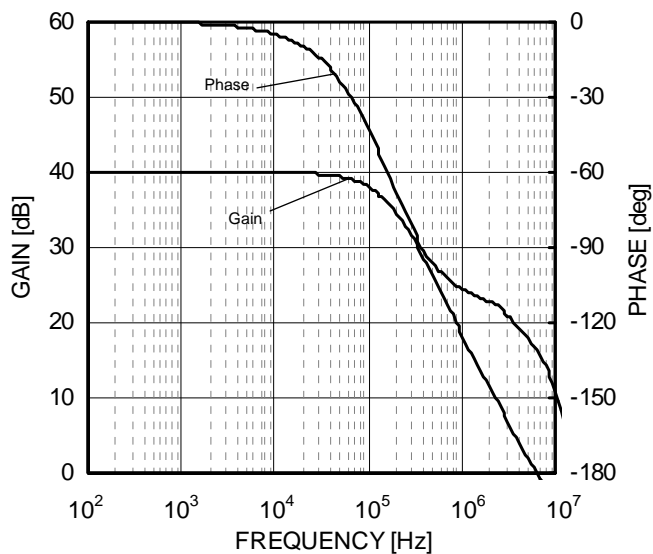

Figure 24.
Voltage Gain • Phase - Frequency
(VCC/VEE=2.5V/-2.5V, Av=40dB, RL=10kΩ)

(*) The above data is measurement value of typical sample, it is not guaranteed.

● Application Information
 NULL method Condition for Test circuit1

VCC, VEE, EK, Vicm Unit: V

Parameter	VF	S1	S2	S3	VCC	VEE	EK	Vicm	calculation
Input Offset Voltage	VF1	ON	ON	OFF	2.5	-2.5	0	0	1
Input Offset Current	VF2	OFF	OFF	OFF	2.5	-2.5	0	0	2
Input Bias Current	VF3	OFF	ON	OFF	2.5	-2.5	0	0	3
	VF4	ON	OFF				0	0	
Large Signal Voltage Gain	VF5	ON	ON	ON	2.5	-2.5	0	0	4
	VF6				2.5	-2.5	0	0	
Common-mode Rejection Ratio (Input common-mode Voltage Range)	VF7	ON	ON	OFF	1	-4	0	0	5
	VF8				3.8	-1.2	0	0	
Power Supply Rejection Ratio	VF9	ON	ON	OFF	1	-1	0	0	6
	VF10				2.5	-2.5	0	0	

-Calculation-

- Input Offset Voltage (Vio)
$$V_{io} = \frac{|VF1|}{1+RF/RS} [V]$$
- Input Offset Current (Iio)
$$I_{io} = \frac{|VF2 - VF1|}{Ri \times (1+RF/RS)} [A]$$
- Input Bias Current (Ib)
$$I_b = \frac{|VF4 - VF3|}{2 \times Ri \times (1+RF/RS)} [A]$$
- Large Signal Voltage Gain (Av)
$$A_v = 20 \times \text{Log} \frac{\Delta EK \times (1+RF/RS)}{|VF5 - VF6|} [dB]$$
- Common-mode Rejection Ration (CMRR)
$$CMRR = 20 \times \text{Log} \frac{\Delta Vicm \times (1+RF/RS)}{|VF8 - VF7|} [dB]$$
- Power supply rejection ratio (PSRR)
$$PSRR = 20 \times \text{Log} \frac{\Delta V_{cc} \times (1+RF/RS)}{|VF10 - VF9|} [dB]$$

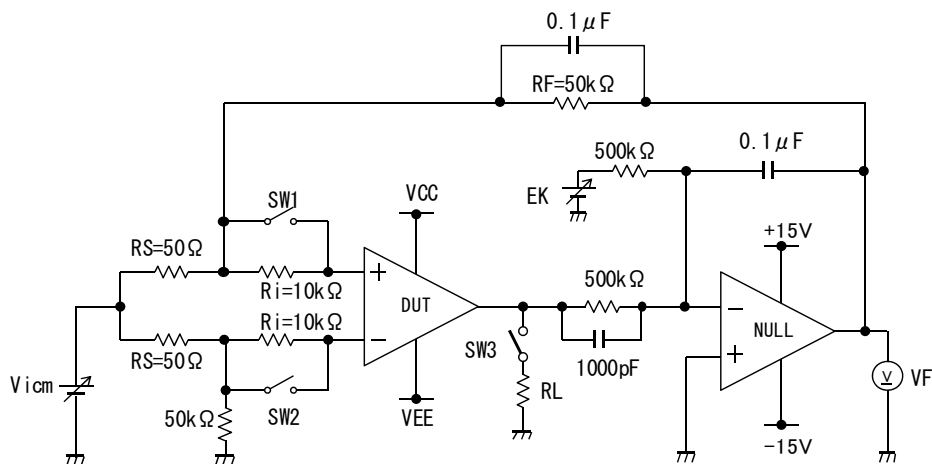

Figure 25. Test circuit1 (one channel only)

Switch Condition for Test Circuit 2

SW No.	SW1	SW2	SW3	SW4	SW5	SW6	SW7	SW8	SW9	SW10	SW11	SW12	SW13	SW14
Supply Current	OFF	OFF	OFF	ON	OFF	ON	OFF	OFF	OFF	OFF	OFF	OFF	OFF	OFF
Maximum Output Voltage(High)	OFF	OFF	ON	OFF	OFF	ON	OFF	OFF	ON	OFF	OFF	OFF	ON	OFF
Maximum Output Voltage(Low)	OFF	OFF	ON	OFF	OFF	ON	OFF	OFF	OFF	OFF	OFF	OFF	ON	OFF
Output Source Current	OFF	OFF	ON	OFF	OFF	ON	OFF	OFF	OFF	OFF	OFF	OFF	OFF	ON
Output Sink Current	OFF	OFF	ON	OFF	OFF	ON	OFF	OFF	OFF	OFF	OFF	OFF	OFF	ON
Slew Rate	OFF	OFF	OFF	ON	OFF	OFF	OFF	ON	ON	ON	OFF	OFF	OFF	OFF
Gain Bandwidth Product	OFF	ON	OFF	OFF	ON	ON	OFF	OFF	ON	ON	OFF	OFF	OFF	OFF
Equivalent Input Noise Voltage	ON	OFF	OFF	OFF	ON	ON	OFF	OFF	OFF	OFF	ON	OFF	OFF	OFF

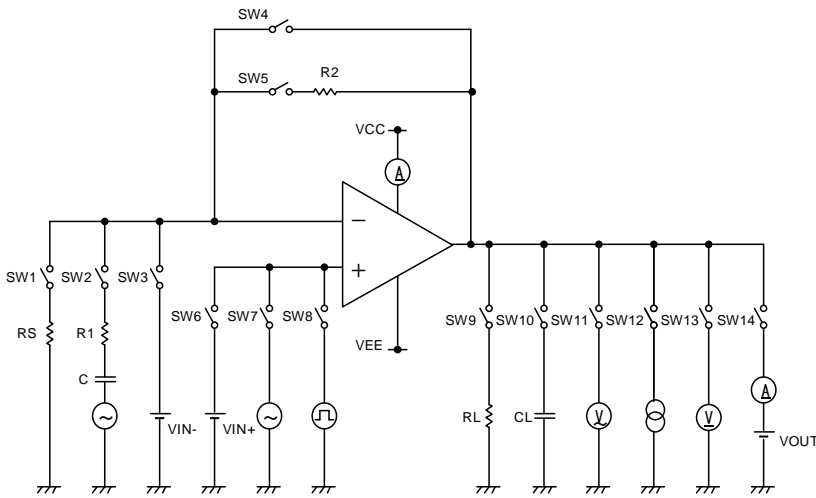

Figure 26. Test Circuit 2 (each Op-Amp)

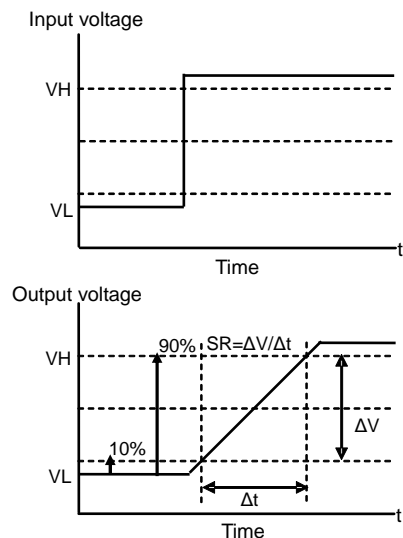
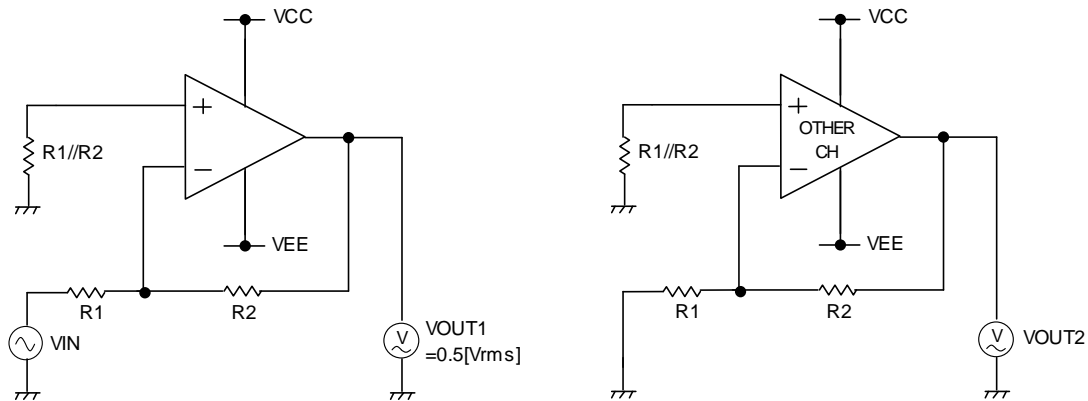

Figure 27. Slew Rate Input Waveform



$$CS = 20 \times \log \frac{100 \times VOUT1}{VOUT2}$$

Figure 28. Test Circuit 3 (Channel Separation)
(VCC=+2.5V, VEE=-2.5V, R1=100Ω, R2=10kΩ)

● Power Dissipation

Power dissipation(total loss) indicates the power that can be consumed by IC at Ta=25°C(normal temperature). IC is heated when it consumed power, and the temperature of IC chip becomes higher than ambient temperature. The temperature that can be accepted by IC chip depends on circuit configuration, manufacturing process, and consumable power is limited. Power dissipation is determined by the temperature allowed in IC chip(maximum junction temperature) and thermal resistance of package(heat dissipation capability). The maximum junction temperature is typically equal to the maximum value in the storage temperature range. Heat generated by consumed power of IC radiates from the mold resin or lead frame of the package. The parameter which indicates this heat dissipation capability(hardness of heat release)is called thermal resistance, represented by the symbol θ_{ja} °C/W. The temperature of IC inside the package can be estimated by this thermal resistance. Figure 29. (a) shows the model of thermal resistance of the package. Thermal resistance θ_{ja} , ambient temperature Ta, maximum junction temperature Tjmax, and power dissipation Pd can be calculated by the equation below:

$$\theta_{ja} = (T_{jmax} - T_a) / P_d \quad \text{°C/W} \quad \dots \dots \dots (I)$$

Derating curve in Figure 29. (b) indicates power that can be consumed by IC with reference to ambient temperature. Power that can be consumed by IC begins to attenuate at certain ambient temperature. This gradient is determined by thermal resistance θ_{ja} . Thermal resistance θ_{ja} depends on chip size, power consumption, package, ambient temperature, package condition, wind velocity, etc even when the same of package is used. Thermal reduction curve indicates a reference value measured at a specified condition. Figure 30. (c) show a derating curve for an example of BA4510.

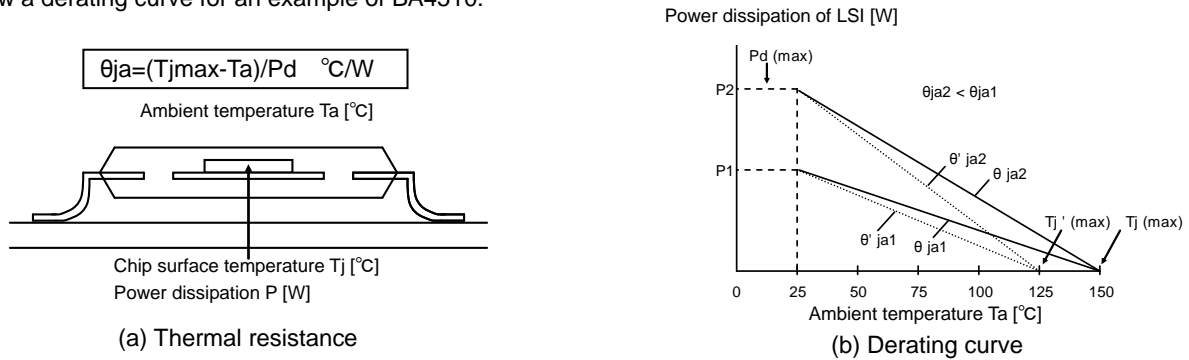
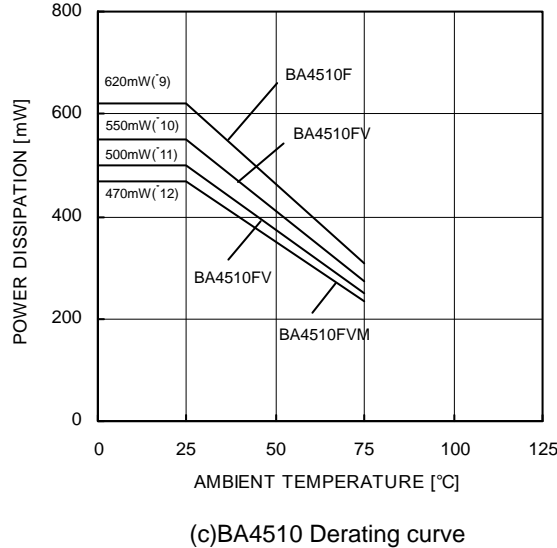

Figure 29. Thermal resistance and derating curve



(c)BA4510 Derating curve

(*9)	(*10)	(*11)	(*12)	Unit
6.2	5.5	5.0	4.8	mW/°C

When using the unit above Ta=25°C, subtract the value above per degree°C. Permissible dissipation is the value. Permissible dissipation is the value when FR4 glass epoxy board 70mm x70mm x1.6mm (cooper foil area below 3%) is mounted.

Figure 30. Derating curve

Application examples

○Voltage follower

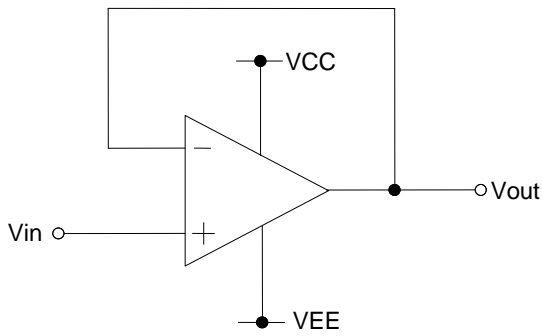

Figure 31. Voltage follower circuit

Voltage gain is 0 dB.
 This circuit controls output voltage (Vout) equal input voltage (Vin), and keeps Vout with stable because of high input impedance and low output impedance.
 Vout is shown next expression.
 $V_{out}=V_{in}$

○Inverting amplifier

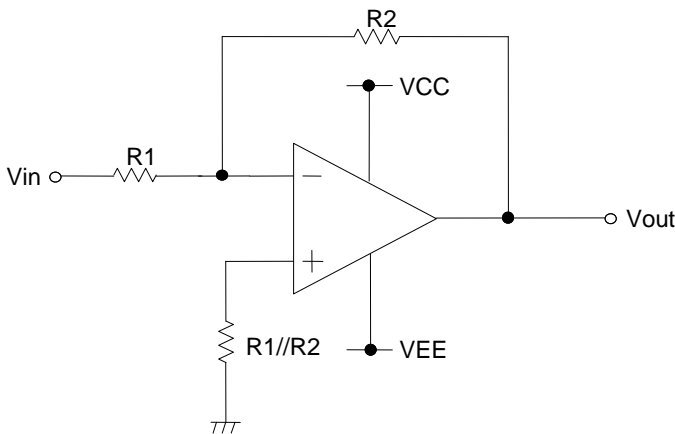

Figure 32. Inverting amplifier circuit

For inverting amplifier, Vin is amplified by voltage gain decided R1 and R2, and phase reversed voltage is output.
 Vout is shown next expression.
 $V_{out}=-\frac{R2}{R1} \cdot V_{in}$
 Input impedance is R1.

○Non-inverting amplifier

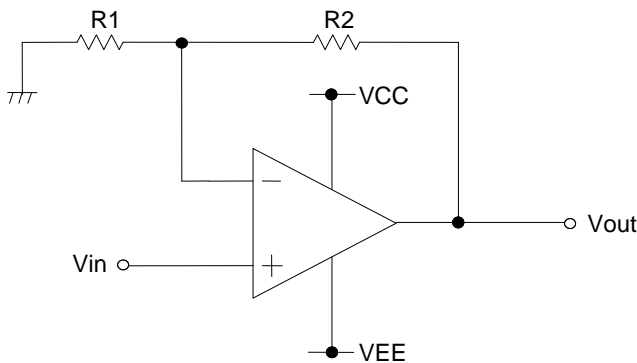

Figure 33. Non-inverting amplifier circuit

For non-inverting amplifier, Vin is amplified by voltage gain decided R1 and R2, and phase is same with Vin.
 Vout is shown next expression.
 $V_{out}=(1 + \frac{R2}{R1}) \cdot V_{in}$
 This circuit performs high input impedance because Input impedance is operational amplifier's input Impedance.

●Operational Notes

- 1) Processing of unused circuit
It is recommended to apply connection (see the Figure 34.) and set the non inverting input terminal at the potential within input common-mode voltage range (Vicm), for any unused circuit.
- 2) Input voltage
Please note that the circuit operates normally only when the input voltage is within the common mode input voltage range of the electric characteristics.
- 3) Maximum output voltage
Because the output voltage range becomes narrow as the output current increases, design the application with margin by considering changes in electrical characteristics and temperature characteristics.
- 4) Short-circuit of output terminal
When output terminal and VCC or VEE terminal are shorted, excessive Output current may flow under some conditions, and heating may destroy IC. It is necessary to connect a resistor as shown in Figure 35. thereby protecting against load shorting.
- 5) Power supply (split supply / single supply) in used
Op-amp operates when specified voltage is applied between VCC and VEE. Therefore, the single supply Op-Amp can be used for double supply Op-Amp as well.
- 6) Power dissipation (Pd)
Use a thermal design that allows for a sufficient margin in light of the power dissipation (Pd) in actual operating conditions.
- 7) Short-circuit between pins and wrong mounting
Pay attention to the assembly direction of the ICs. Wrong mounting direction or shorts between terminals, GND, or other components on the circuits, can damage the IC.
- 8) Use in strong electromagnetic field
Using the ICs in strong electromagnetic field can cause operation malfunction.
- 9) Radiation
This IC is not designed to be radiation-resistant.
- 10) Handling of IC
When stress is applied to IC because of deflection or bend of board, the characteristics may fluctuate due to piezo resistance effects.
- 11) Inspection on set board
During testing, turn on or off the power before mounting or dismantling the board from the test Jig. Do not power up the board without waiting for the output capacitors to discharge. The capacitors in the low output impedance terminal can stress the device. Pay attention to the electro static voltages during IC handling, transportation, and storage.
- 12) Output capacitor
When VCC terminal is shorted to VEE (GND) potential and an electric charge has accumulated on the external capacitor, connected to output terminal, accumulated charge may be discharged VCC terminal via the parasitic element within the circuit or terminal protection element. The element in the circuit may be damaged (thermal destruction). When using this IC for an application circuit where there is oscillation, output capacitor load does not occur, as when using this IC as a voltage comparator. Set the capacitor connected to output terminal below 0.1 μ F in order to prevent damage to IC.

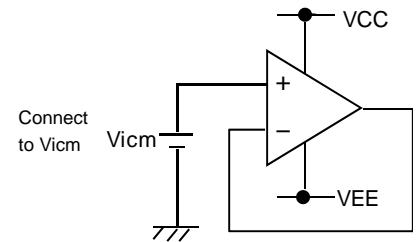

Figure 34. The example of application circuit for unused op-amp

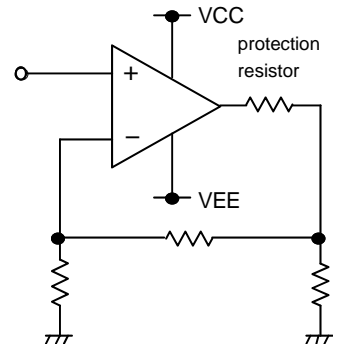

Figure 35. The example of output short protection

Status of this document

The Japanese version of this document is formal specification. A customer may use this translation version only for a reference to help reading the formal version.

If there are any differences in translation version of this document formal version takes priority.

●Physical Dimensions Tape and Reel Information

SOP8

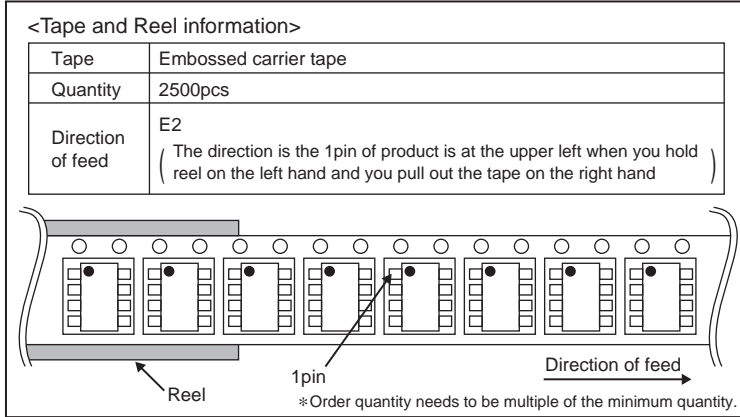
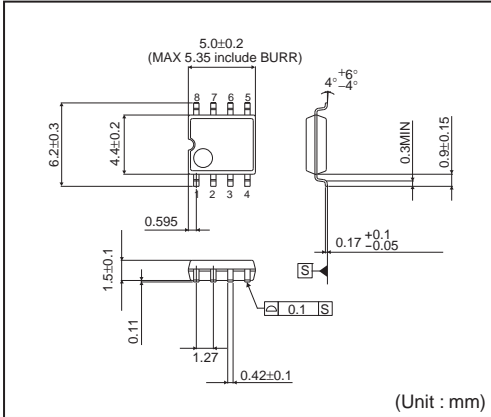

SSOP-B8

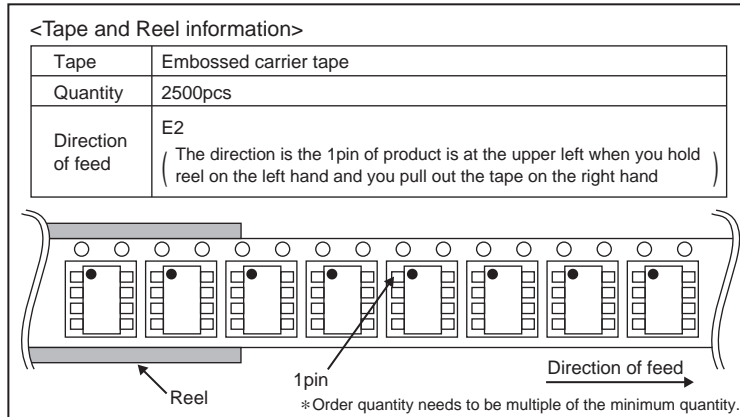
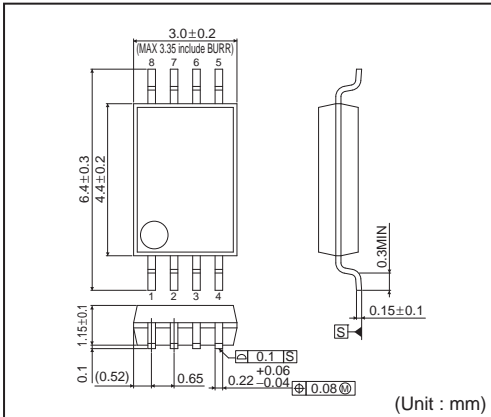

TSSOP-B8

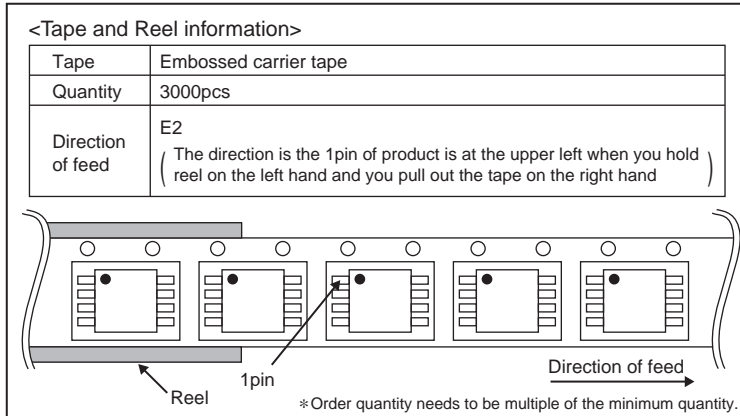
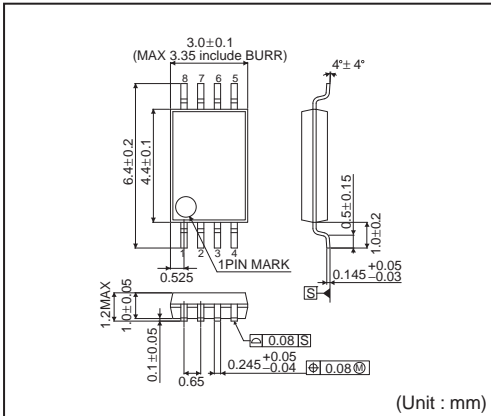

MSOP8

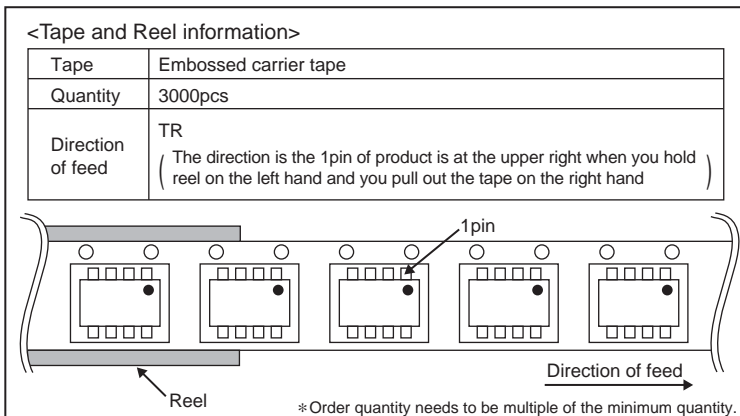
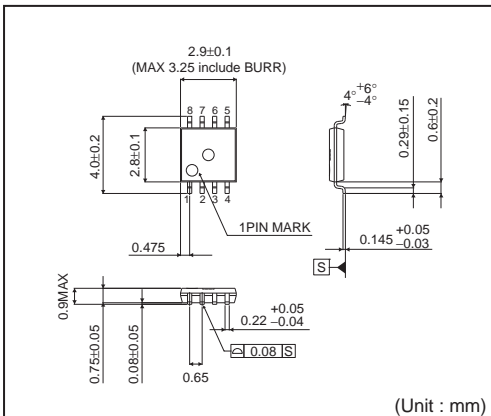

●Marking Diagrams

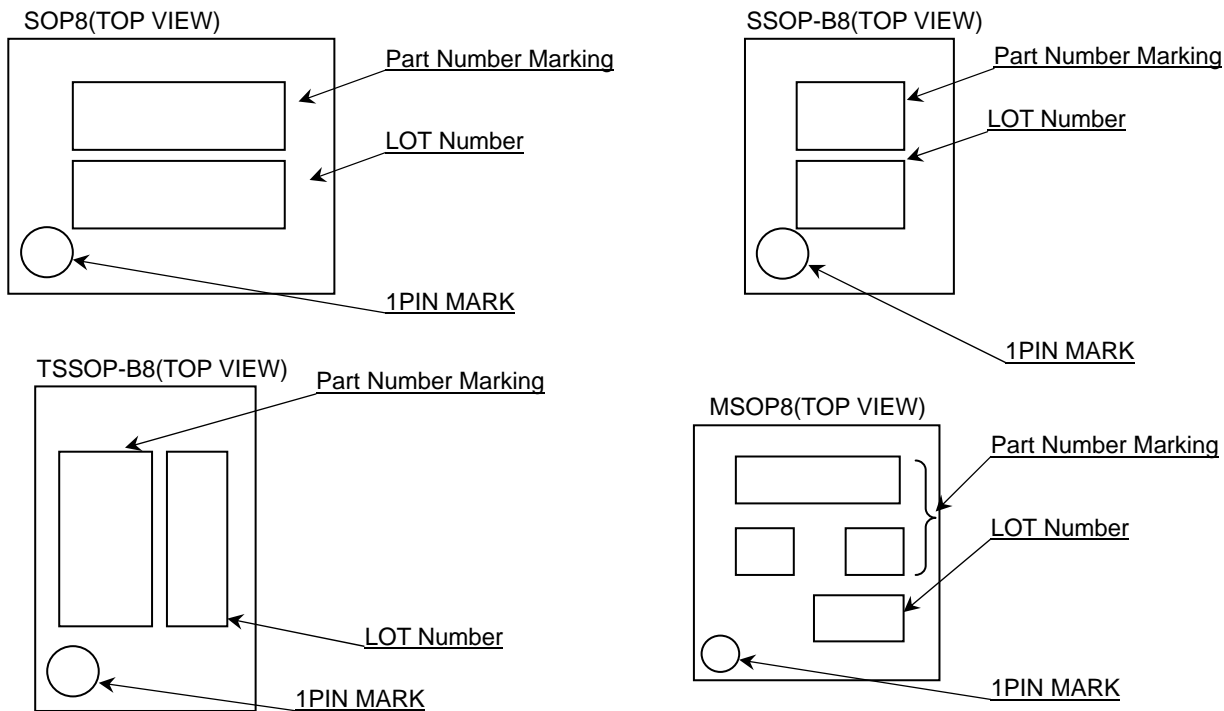

Product Name		Package Type	Marking
BA4510	F	SOP8	4510
	FV	SSOP-B8	
	FVT	TSSOP-B8	
	FVM	MSOP8	

●Land pattern data

all dimensions in mm

PKG	Land pitch e	Land space MIE	Land length $\geq l_2$	Land width b2
SOP8	1.27	4.60	1.10	0.76
SSOP-B8	0.65	4.60	1.20	0.35
TSSOP-B8	0.65	4.60	1.20	0.35
MSOP8	0.65	2.62	0.99	0.35

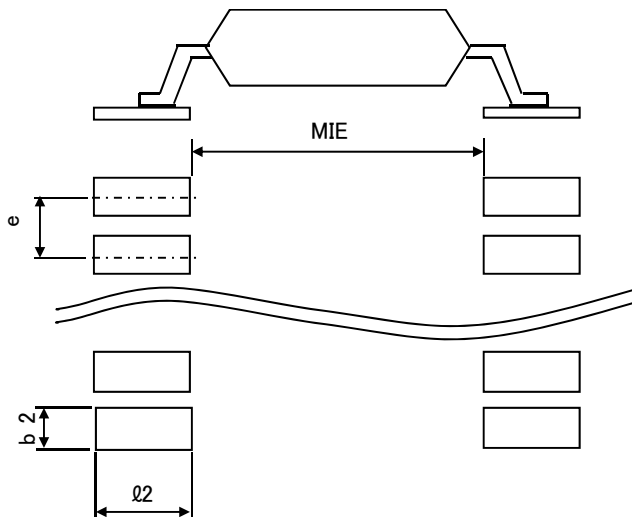

●Revision History

Date	Revision	Changes
2012.11.7	001	New Release

Notice

Precaution on using ROHM Products

- Our Products are designed and manufactured for application in ordinary electronic equipments (such as AV equipment, OA equipment, telecommunication equipment, home electronic appliances, amusement equipment, etc.). If you intend to use our Products in devices requiring extremely high reliability (such as medical equipment ^(Note 1), transport equipment, traffic equipment, aircraft/spacecraft, nuclear power controllers, fuel controllers, car equipment including car accessories, safety devices, etc.) and whose malfunction or failure may cause loss of human life, bodily injury or serious damage to property ("Specific Applications"), please consult with the ROHM sales representative in advance. Unless otherwise agreed in writing by ROHM in advance, ROHM shall not be in any way responsible or liable for any damages, expenses or losses incurred by you or third parties arising from the use of any ROHM's Products for Specific Applications.

(Note1) Medical Equipment Classification of the Specific Applications

JAPAN	USA	EU	CHINA
CLASS III	CLASS III	CLASS II b	CLASS III
CLASS IV		CLASS III	

- ROHM designs and manufactures its Products subject to strict quality control system. However, semiconductor products can fail or malfunction at a certain rate. Please be sure to implement, at your own responsibilities, adequate safety measures including but not limited to fail-safe design against the physical injury, damage to any property, which a failure or malfunction of our Products may cause. The following are examples of safety measures:
 - Installation of protection circuits or other protective devices to improve system safety
 - Installation of redundant circuits to reduce the impact of single or multiple circuit failure
- Our Products are designed and manufactured for use under standard conditions and not under any special or extraordinary environments or conditions, as exemplified below. Accordingly, ROHM shall not be in any way responsible or liable for any damages, expenses or losses arising from the use of any ROHM's Products under any special or extraordinary environments or conditions. If you intend to use our Products under any special or extraordinary environments or conditions (as exemplified below), your independent verification and confirmation of product performance, reliability, etc. prior to use, must be necessary:
 - Use of our Products in any types of liquid, including water, oils, chemicals, and organic solvents
 - Use of our Products outdoors or in places where the Products are exposed to direct sunlight or dust
 - Use of our Products in places where the Products are exposed to sea wind or corrosive gases, including Cl₂, H₂S, NH₃, SO₂, and NO₂
 - Use of our Products in places where the Products are exposed to static electricity or electromagnetic waves
 - Use of our Products in proximity to heat-producing components, plastic cords, or other flammable items
 - Sealing or coating our Products with resin or other coating materials
 - Use of our Products without cleaning residue of flux (even if you use no-clean type fluxes, cleaning residue of flux is recommended); or Washing our Products by using water or water-soluble cleaning agents for cleaning residue after soldering
 - Use of the Products in places subject to dew condensation
- The Products are not subject to radiation-proof design.
- Please verify and confirm characteristics of the final or mounted products in using the Products.
- In particular, if a transient load (a large amount of load applied in a short period of time, such as pulse. is applied, confirmation of performance characteristics after on-board mounting is strongly recommended. Avoid applying power exceeding normal rated power; exceeding the power rating under steady-state loading condition may negatively affect product performance and reliability.
- De-rate Power Dissipation (Pd) depending on Ambient temperature (Ta). When used in sealed area, confirm the actual ambient temperature.
- Confirm that operation temperature is within the specified range described in the product specification.
- ROHM shall not be in any way responsible or liable for failure induced under deviant condition from what is defined in this document.

Precaution for Mounting / Circuit board design

- When a highly active halogenous (chlorine, bromine, etc.) flux is used, the residue of flux may negatively affect product performance and reliability.
- In principle, the reflow soldering method must be used; if flow soldering method is preferred, please consult with the ROHM representative in advance.

For details, please refer to ROHM Mounting specification

Precautions Regarding Application Examples and External Circuits

1. If change is made to the constant of an external circuit, please allow a sufficient margin considering variations of the characteristics of the Products and external components, including transient characteristics, as well as static characteristics.
2. You agree that application notes, reference designs, and associated data and information contained in this document are presented only as guidance for Products use. Therefore, in case you use such information, you are solely responsible for it and you must exercise your own independent verification and judgment in the use of such information contained in this document. ROHM shall not be in any way responsible or liable for any damages, expenses or losses incurred by you or third parties arising from the use of such information.

Precaution for Electrostatic

This Product is electrostatic sensitive product, which may be damaged due to electrostatic discharge. Please take proper caution in your manufacturing process and storage so that voltage exceeding the Products maximum rating will not be applied to Products. Please take special care under dry condition (e.g. Grounding of human body / equipment / solder iron, isolation from charged objects, setting of ionizer, friction prevention and temperature / humidity control).

Precaution for Storage / Transportation

1. Product performance and soldered connections may deteriorate if the Products are stored in the places where:
 - [a] the Products are exposed to sea winds or corrosive gases, including Cl₂, H₂S, NH₃, SO₂, and NO₂
 - [b] the temperature or humidity exceeds those recommended by ROHM
 - [c] the Products are exposed to direct sunshine or condensation
 - [d] the Products are exposed to high Electrostatic
2. Even under ROHM recommended storage condition, solderability of products out of recommended storage time period may be degraded. It is strongly recommended to confirm solderability before using Products of which storage time is exceeding the recommended storage time period.
3. Store / transport cartons in the correct direction, which is indicated on a carton with a symbol. Otherwise bent leads may occur due to excessive stress applied when dropping of a carton.
4. Use Products within the specified time after opening a humidity barrier bag. Baking is required before using Products of which storage time is exceeding the recommended storage time period.

Precaution for Product Label

QR code printed on ROHM Products label is for ROHM's internal use only.

Precaution for Disposition

When disposing Products please dispose them properly using an authorized industry waste company.

Precaution for Foreign Exchange and Foreign Trade act

Since our Products might fall under controlled goods prescribed by the applicable foreign exchange and foreign trade act, please consult with ROHM representative in case of export.

Precaution Regarding Intellectual Property Rights

1. All information and data including but not limited to application example contained in this document is for reference only. ROHM does not warrant that foregoing information or data will not infringe any intellectual property rights or any other rights of any third party regarding such information or data. ROHM shall not be in any way responsible or liable for infringement of any intellectual property rights or other damages arising from use of such information or data.:
2. No license, expressly or implied, is granted hereby under any intellectual property rights or other rights of ROHM or any third parties with respect to the information contained in this document.

Other Precaution



1. This document may not be reprinted or reproduced, in whole or in part, without prior written consent of ROHM.
2. The Products may not be disassembled, converted, modified, reproduced or otherwise changed without prior written consent of ROHM.
3. In no event shall you use in any way whatsoever the Products and the related technical information contained in the Products or this document for any military purposes, including but not limited to, the development of mass-destruction weapons.
4. The proper names of companies or products described in this document are trademarks or registered trademarks of ROHM, its affiliated companies or third parties.

General Precaution

1. Before you use our Products, you are requested to carefully read this document and fully understand its contents. ROHM shall not be in any way responsible or liable for failure, malfunction or accident arising from the use of any ROHM's Products against warning, caution or note contained in this document.
2. All information contained in this document is current as of the issuing date and subject to change without any prior notice. Before purchasing or using ROHM's Products, please confirm the latest information with a ROHM sales representative.
3. The information contained in this document is provided on an "as is" basis and ROHM does not warrant that all information contained in this document is accurate and/or error-free. ROHM shall not be in any way responsible or liable for any damages, expenses or losses incurred by you or third parties resulting from inaccuracy or errors of or concerning such information.

Looking for pricing, stock, or lifecycle information?

Click below to explore more details on WIN SOURCE:

-  [View BA4510F-E2 on WIN SOURCE](#)
-  [Rohm Semiconductor](#) Information

Optimize Your Supply Chain with WIN SOURCE Solutions

-  Global Sourcing Solution
-  Obsolete Management
-  Cost Control Management
-  Shortage Management
-  Alternative Solution
-  Excess Inventory Management