



**THE DATASHEET OF
CY8C29466-24SXIT**





Please note that Cypress is an Infineon Technologies Company.

The document following this cover page is marked as “Cypress” document as this is the company that originally developed the product. Please note that Infineon will continue to offer the product to new and existing customers as part of the Infineon product portfolio.

Continuity of document content

The fact that Infineon offers the following product as part of the Infineon product portfolio does not lead to any changes to this document. Future revisions will occur when appropriate, and any changes will be set out on the document history page.

Continuity of ordering part numbers

Infineon continues to support existing part numbers. Please continue to use the ordering part numbers listed in the datasheet for ordering.

Features

- Powerful Harvard-architecture processor
 - M8C processor speeds to 24 MHz
 - Two 8 × 8 multiply, 32-bit accumulate
 - Low power at high speed
 - Operating voltage: 3.0 V to 5.25 V
 - Operating voltages down to 1.0 V using on-chip switch mode pump (SMP)
 - Industrial temperature range: -40 °C to +85 °C
- Advanced peripherals (PSoC® blocks)
 - 12 rail-to-rail analog PSoC blocks provide:
 - Up to 14-bit analog-to-digital converters (ADCs)
 - Up to 9-bit digital-to-analog converters (DACs)
 - Programmable gain amplifiers (PGAs)
 - Programmable filters and comparators
 - 16 digital PSoC blocks provide:
 - 8- to 32-bit timers and counters, 8- and 16-bit pulse-width modulators (PWMs)
 - Cyclical redundancy check (CRC) and pseudo random sequence (PRS) modules
 - Up to four full-duplex universal asynchronous receiver transmitters (UARTs)
 - Multiple serial peripheral interface (SPI) masters or slaves
 - Can connect to all general-purpose I/O (GPIO) pins
 - Create complex peripherals by combining blocks
- Precision, programmable clocking
 - Internal ±5% [1] 24- / 48-MHz main oscillator
 - 24- / 48-MHz with optional 32.768 kHz crystal
 - Optional external oscillator, up to 24 MHz
 - Internal oscillator for watchdog and sleep
- Flexible on-chip memory
 - 32 KB flash program storage 50,000 erase/write cycles
 - 2 KB static random access memory (SRAM) data storage
 - In-system serial programming (ISSP)
 - Partial flash updates
 - Flexible protection modes
 - Electrically erasable programmable read-only memory (EEPROM) emulation in flash
- Programmable pin configurations
 - 25-mA sink, 10-mA source on all GPIOs
 - Pull-up, pull-down, high Z, strong, or open-drain drive modes on all GPIOs
 - Eight standard analog inputs on GPIOs, plus four additional analog inputs with restricted routing

- Four 40 mA analog outputs on GPIOs
- Configurable interrupt on all GPIOs
- Additional system resources
 - I²C slave, master, and multi-master to 400 kHz
 - Watchdog and sleep timers
 - User-configurable low-voltage detection (LVD)
 - Integrated supervisory circuit
 - On-chip precision voltage reference
- Complete development tools
 - Free development software (PSoC Designer™)
 - Full-featured in-circuit emulator (ICE) and programmer
 - Full-speed emulation
 - Complex breakpoint structure
 - 128 KB trace memory
 - Complex events
 - C compilers, assembler, and linker

Logic Block Diagram

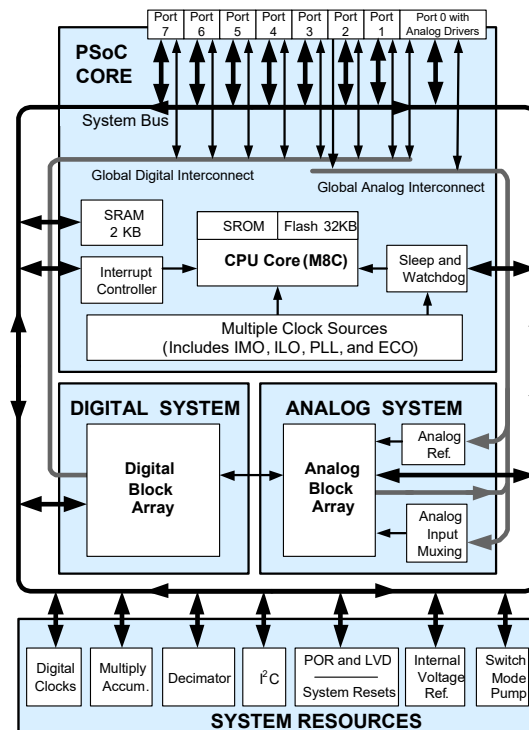

Errata: For information on silicon errata, see "Errata" on page 63. Details include trigger conditions, devices affected, and proposed workaround.

Note

1. Errata: When the device is operated within 0 °C to 70 °C, the frequency tolerance is reduced to ±2.5%, but if operated at extreme temperature (below 0 °C or above 70 °C), frequency tolerance deviates from ±2.5% to ±5%. For more information, see [Errata on page 63](#).

More Information

Cypress provides a wealth of data at www.cypress.com to help you to select the right PSoC device for your design, and to help you to quickly and effectively integrate the device into your design. For a comprehensive list of resources, see the knowledge base article “How to Design with PSoC® 1, PowerPSoC®, and PLC – KBA88292”. Following is an abbreviated list for PSoC 1:

- Overview: PSoC Portfolio, PSoC Roadmap
- Product Selectors: [PSoC 1](#), [PSoC 3](#), [PSoC 4](#), [PSoC 5LP](#)
- In addition, PSoC Designer includes a device selection tool.
- Application notes: Cypress offers a large number of PSoC application notes covering a broad range of topics, from basic to advanced level. Recommended application notes for getting started with PSoC 1 are:
 - [Getting Started with PSoC® 1 – AN75320](#)
 - [PSoC® 1 - Getting Started with GPIO – AN2094](#)
 - [PSoC® 1 Analog Structure and Configuration – AN74170](#)
 - [PSoC® 1 Switched Capacitor Analog Blocks – AN2041](#)
 - [Selecting Analog Ground and Reference – AN2219](#)

Note: For CY8C29X66 devices related Application note please click [here](#).

- Development Kits:
 - [CY3210-PSocEval1](#) supports all PSoC 1 Mixed-Signal Array families, including automotive, except CY8C25/26xxx devices. The kit includes an LCD module, potentiometer, LEDs, and breadboarding space.
 - [CY3214-PSocEvalUSB](#) features a development board for the CY8C24x94 PSoC device. Special features of the board include USB and CapSense development and debugging support.

Note: For CY8C29X66 devices related Development Kits please click [here](#).

The [MiniProg1](#) and [MiniProg3](#) devices provide interfaces for flash programming and debug.

PSoC Designer

[PSoC Designer](#) is a free Windows-based Integrated Design Environment (IDE). Develop your applications using a library of pre-characterized analog and digital peripherals in a drag-and-drop design environment. Then, customize your design leveraging the dynamically generated API libraries of code. [Figure 1](#) shows PSoC Designer windows. **Note:** This is not the default view.

1. **Global Resources** – all device hardware settings.
2. **Parameters** – the parameters of the currently selected User Modules.
3. **Pinout** – information related to device pins.
4. **Chip-Level Editor** – a diagram of the resources available on the selected chip.
5. **Datasheet** – the datasheet for the currently selected UM
6. **User Modules** – all available User Modules for the selected device.
7. **Device Resource Meter** – device resource usage for the current project configuration.
8. **Workspace** – a tree level diagram of files associated with the project.
9. **Output** – output from project build and debug operations.

Note: For detailed information on PSoC Designer, go to PSoC® Designer > Help > Documentation > Designer Specific Documents > IDE User Guide.

Figure 1. PSoC Designer Layout

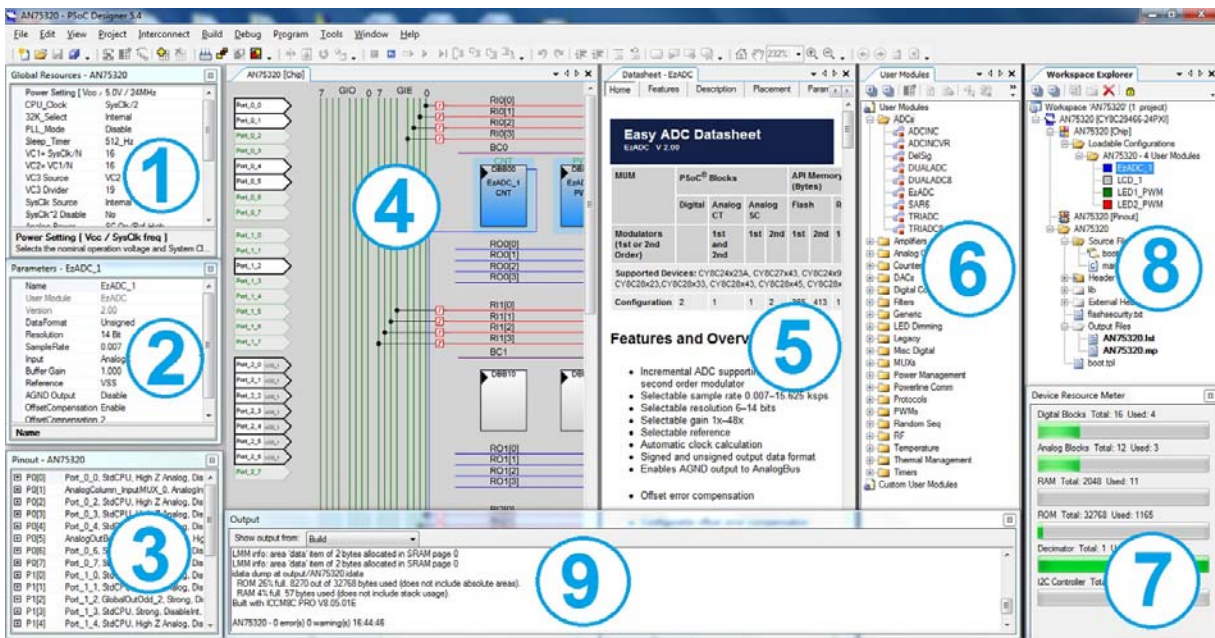

Contents

| | | | |
|---|-----------|--|-----------|
| PSoC Functional Overview | 4 | Thermal Impedances | 51 |
| PSoC Core | 4 | Capacitance on Crystal Pins | 51 |
| Digital System | 4 | Solder Reflow Specifications | 51 |
| Analog System | 5 | Development Tool Selection | 52 |
| Additional System Resources | 6 | Software | 52 |
| PSoC Device Characteristics | 6 | Development Kits | 52 |
| Development Tools | 7 | Evaluation Tools | 52 |
| PSoC Designer Software Subsystems | 7 | Device Programmers | 53 |
| Designing with PSoC Designer | 8 | Accessories (Emulation and Programming) | 53 |
| Select User Modules | 8 | Ordering Information | 54 |
| Configure User Modules | 8 | Ordering Code Definitions | 54 |
| Organize and Connect | 9 | Acronyms | 55 |
| Generate, Verify, and Debug | 9 | Reference Documents | 55 |
| Pinouts | 10 | Document Conventions | 56 |
| 28-Pin Part Pinout | 10 | Units of Measure | 56 |
| 44-Pin Part Pinout | 11 | Numeric Conventions | 56 |
| 48-Pin Part Pinout | 12 | Glossary | 56 |
| 100-Pin Part Pinout | 14 | Errata | 61 |
| 100-Pin Part Pinout (On-Chip Debug) | 16 | Part Numbers Affected | 61 |
| Register Reference | 18 | Qualification Status | 61 |
| Register Conventions | 18 | Errata Summary | 61 |
| Register Mapping Tables | 18 | Document History Page | 63 |
| Electrical Specifications | 21 | Sales, Solutions, and Legal Information | 67 |
| Absolute Maximum Ratings | 21 | Worldwide Sales and Design Support | 67 |
| Operating Temperature | 22 | Products | 67 |
| DC Electrical Characteristics | 22 | PSoC® Solutions | 67 |
| AC Electrical Characteristics | 38 | Cypress Developer Community | 67 |
| Packaging Information | 47 | Technical Support | 67 |
| Packaging Dimensions | 47 | | |

PSoC Functional Overview

The PSoC family consists of many Programmable System-on-Chip controller devices. These devices are designed to replace multiple traditional microcontroller unit (MCU)-based system components with one, low-cost single-chip programmable device. PSoC devices include configurable blocks of analog and digital logic, as well as programmable interconnects. This architecture allows you to create customized peripheral configurations that match the requirements of each individual application. Additionally, a fast central processing unit (CPU), flash program memory, SRAM data memory, and configurable I/O are included in a range of convenient pinouts and packages.

The PSoC architecture, as illustrated in the [Logic Block Diagram on page 1](#), consists of four main areas: PSoC core, digital system, analog system, and system resources. Configurable global busing allows all of the device resources to be combined into a complete custom system. The PSoC CY8C29x66 family can have up to five I/O ports that connect to the global digital and analog interconnects, providing access to 8 digital blocks and 12 analog blocks.

PSoC Core

The PSoC core is a powerful engine that supports a rich feature set. The core includes a CPU, memory, clocks, and configurable GPIOs.

The M8C CPU core is a powerful processor with speeds up to 24 MHz, providing a 4 million instructions per second (MIPS) 8-bit Harvard-architecture microprocessor. The CPU uses an interrupt controller with 17 vectors, to simplify programming of real-time embedded events. Program execution is timed and protected using the included sleep and watchdog timers (WDT).

Memory uses 32 KB of flash for program storage, 2 KB of SRAM for data storage, and up to 2 KB of EEPROM emulated using the flash. Program flash uses four protection levels on blocks of 64 bytes, allowing customized software information protection (IP).

The PSoC device incorporates flexible internal clock generators, including a 24 MHz internal main oscillator (IMO) accurate to 5% [2] over temperature and voltage. The 24 MHz IMO can also be doubled to 48 MHz for use by the digital system. A low-power 32 kHz internal low speed oscillator (ILO) is provided for the sleep timer and WDT. If crystal accuracy is desired, the 32.768 kHz external crystal oscillator (ECO) is available for use as a real-time clock (RTC) and can optionally generate a crystal-accurate 24 MHz system clock using a PLL. The clocks, together with programmable clock dividers (as a system resource), provide the flexibility to integrate almost any timing requirement into the PSoC device.

PSoC GPIOs provide connection to the CPU, and digital and analog resources of the device. Each pin's drive mode may be selected from eight options, allowing great flexibility in external interfacing. Every pin also has the capability to generate a system interrupt on high level, low level, and change from last read.

Digital System

The digital system is composed of 16 digital PSoC blocks. Each block is an 8-bit resource that can be used alone or combined with other blocks to form 8-, 16-, 24-, and 32-bit peripherals, which are called user modules.

Figure 2. Digital System Block Diagram

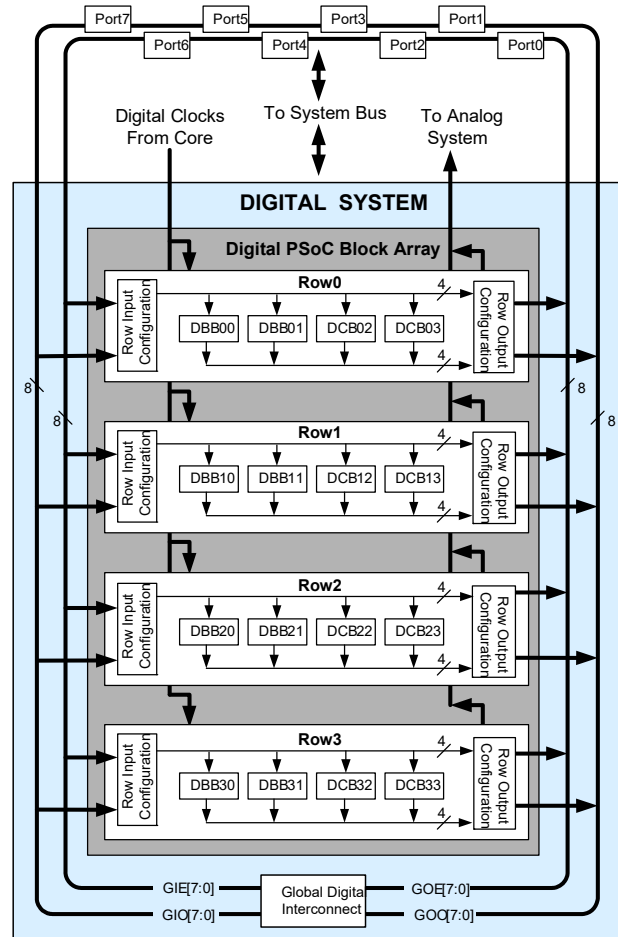

Note

- Errata:** When the device is operated within 0 °C to 70 °C, the frequency tolerance is reduced to ±2.5%, but if operated at extreme temperature (below 0 °C or above 70 °C), frequency tolerance deviates from ±2.5% to ±5%. For more information, see [Errata on page 63](#).

Digital peripheral configurations include:

- PWMs (8- and 16-bit)
- PWMs with dead band (8- and 16-bit)
- Counters (8- to 32-bit)
- Timers (8- to 32-bit)
- UART 8-bit with selectable parity (up to 2)
- SPI slave and master (up to 2)
- I²C slave and multi-master (one available as a system resource)
- CRC generator (8- to 32-bit)
- IrDA (up to 2)
- PRS generators (8- to 32-bit)

The digital blocks can be connected to any GPIO through a series of global buses that can route any signal to any pin. The buses also allow for signal multiplexing and for performing logic operations. This configurability frees your designs from the constraints of a fixed peripheral controller.

Digital blocks are provided in rows of four, where the number of blocks varies by PSoC device family. This allows you the optimum choice of system resources for your application. Family resources are shown in the table titled “PSoC Device Characteristics” on page 6.

Analog System

The analog system is composed of 12 configurable blocks, each containing an opamp circuit that allows the creation of complex analog signal flows. Analog peripherals are very flexible and can be customized to support specific application requirements. Some of the more common PSoC analog functions (most available as user modules) are:

- ADCs (up to 4, with 6- to 14-bit resolution; selectable as incremental, delta sigma, and SAR)
- Filters (2-, 4-, 6-, and 8-pole band pass, low pass, and notch)
- Amplifiers (up to 4, with selectable gain to 48x)
- Instrumentation amplifiers (up to 2, with selectable gain to 93x)
- Comparators (up to 4, with 16 selectable thresholds)
- DACs (up to 4, with 6-bit to 9-bit resolution)
- Multiplying DACs (up to 4, with 6-bit to 9-bit resolution)
- High current output drivers (four with 30-mA drive as a core resource)
- 1.3-V reference (as a system resource)

- DTMF Dialer
- Modulators
- Correlators
- Peak detectors
- Many other topologies possible

Analog blocks are provided in columns of three, which includes one continuous time (CT) and two switched capacitor (SC) blocks, as shown in Figure 3.

Figure 3. Analog System Block Diagram

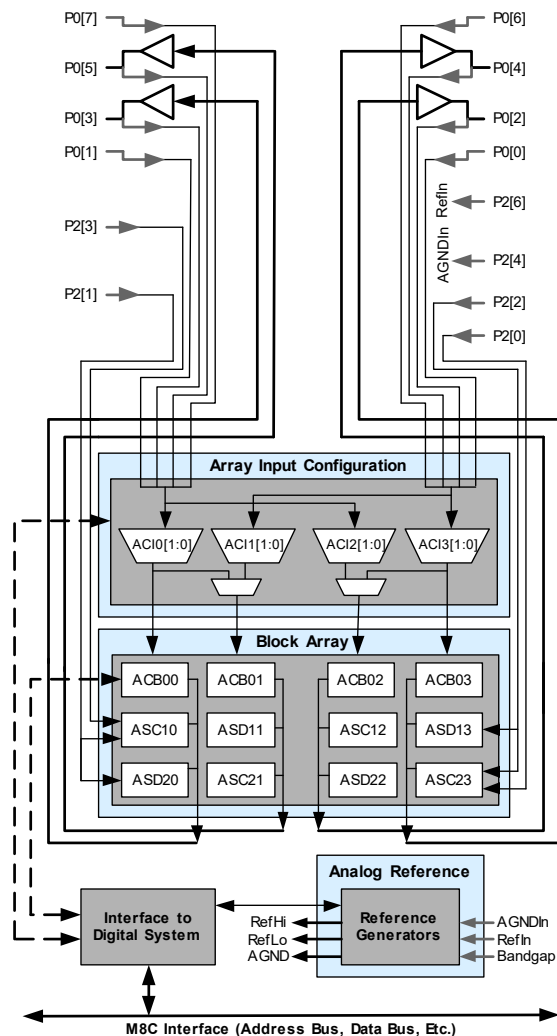

Additional System Resources

System resources, some of which were previously listed, provide additional capability useful to complete systems. Additional resources include a multiplier, decimator, switch mode pump, low-voltage detection, and power-on-reset (POR).

- Digital clock dividers provide three customizable clock frequencies for use in applications. The clocks can be routed to both the digital and analog systems. Additional clocks can be generated using digital PSoC blocks as clock dividers.
- Multiply accumulate (MAC) provides a fast 8-bit multiplier with 32-bit accumulate, to assist in general math and digital filters.
- The decimator provides a custom hardware filter for digital signal processing applications including the creation of delta sigma ADCs.
- The I²C module provides 100 and 400 kHz communication over two wires. Slave, master, and multi-master modes are all supported.
- LVD interrupts can signal the application of falling voltage levels, while the advanced POR circuit eliminates the need for a system supervisor.
- An internal 1.3 V reference provides an absolute reference for the analog system, including ADCs and DACs.
- An integrated switch-mode pump (SMP) generates normal operating voltages from a single 1.2 V battery cell, providing a low cost boost converter.

PSoC Device Characteristics

Depending on your PSoC device characteristics, the digital and analog systems can have 16, 8, or 4 digital blocks and 12, 6, or 4 analog blocks. The following table lists the resources available for specific PSoC device groups. The PSoC device covered by this datasheet is highlighted.

Table 1. PSoC Device Characteristics

| PSoC Part Number | Digital I/O | Digital Rows | Digital Blocks | Analog Inputs | Analog Outputs | Analog Columns | Analog Blocks | SRAM Size | Flash Size |
|------------------|-------------|--------------|----------------|---------------|----------------|----------------|-----------------------------|-----------|------------|
| CY8C29x66 | up to 64 | 4 | 16 | up to 12 | 4 | 4 | 12 | 2 K | 32 K |
| CY8C28xxx | up to 44 | up to 3 | up to 12 | up to 44 | up to 4 | up to 6 | up to 12 + 4 ^[3] | 1 K | 16 K |
| CY8C27x43 | up to 44 | 2 | 8 | up to 12 | 4 | 4 | 12 | 256 | 16 K |
| CY8C24x94 | up to 56 | 1 | 4 | up to 48 | 2 | 2 | 6 | 1 K | 16 K |
| CY8C24x23A | up to 24 | 1 | 4 | up to 12 | 2 | 2 | 6 | 256 | 4 K |
| CY8C23x33 | up to 26 | 1 | 4 | up to 12 | 2 | 2 | 4 | 256 | 8 K |
| CY8C22x45 | up to 38 | 2 | 8 | up to 38 | 0 | 4 | 6 ^[3] | 1 K | 16 K |
| CY8C21x45 | up to 24 | 1 | 4 | up to 24 | 0 | 4 | 6 ^[3] | 512 | 8 K |
| CY8C21x34 | up to 28 | 1 | 4 | up to 28 | 0 | 2 | 4 ^[3] | 512 | 8 K |
| CY8C21x23 | up to 16 | 1 | 4 | up to 8 | 0 | 2 | 4 ^[3] | 256 | 4 K |
| CY8C20x34 | up to 28 | 0 | 0 | up to 28 | 0 | 0 | 3 ^[3,4] | 512 | 8 K |
| CY8C20xx6 | up to 36 | 0 | 0 | up to 36 | 0 | 0 | 3 ^[3,4] | up to 2 K | up to 32 K |

Notes

3. Limited analog functionality.
4. Two analog blocks and one CapSense®.

Development Tools

PSoC Designer™ is the revolutionary Integrated Design Environment (IDE) that you can use to customize PSoC to meet your specific application requirements. PSoC Designer software accelerates system design and time to market. Develop your applications using a library of precharacterized analog and digital peripherals (called user modules) in a drag-and-drop design environment. Then, customize your design by leveraging the dynamically generated application programming interface (API) libraries of code. Finally, debug and test your designs with the integrated debug environment, including in-circuit emulation and standard software debug features. PSoC Designer includes:

- Application editor graphical user interface (GUI) for device and user module configuration and dynamic reconfiguration
- Extensive user module catalog
- Integrated source-code editor (C and assembly)
- Free C compiler with no size restrictions or time limits
- Built-in debugger
- In-circuit emulation
- Built-in support for communication interfaces:
 - Hardware and software I²C slaves and masters
 - Full-speed USB 2.0
 - Up to four full-duplex universal asynchronous receiver/transmitters (UARTs), SPI master and slave, and wireless

PSoC Designer supports the entire library of PSoC 1 devices and runs on Windows XP, Windows Vista, and Windows 7.

PSoC Designer Software Subsystems

Design Entry

In the chip-level view, choose a base device to work with. Then select different onboard analog and digital components that use the PSoC blocks, which are called user modules. Examples of user modules are analog-to-digital converters (ADCs), digital-to-analog converters (DACs), amplifiers, and filters. Configure the user modules for your chosen application and connect them to each other and to the proper pins. Then generate your project. This prepopulates your project with APIs and libraries that you can use to program your application.

The tool also supports easy development of multiple configurations and dynamic reconfiguration. Dynamic reconfiguration makes it possible to change configurations at run time. In essence, this allows you to use more than 100 percent of PSoC's resources for an application.

Code Generation Tools

The code generation tools work seamlessly within the PSoC Designer interface and have been tested with a full range of debugging tools. You can develop your design in C, assembly, or a combination of the two.

Assemblers. The assemblers allow you to merge assembly code seamlessly with C code. Link libraries automatically use absolute addressing or are compiled in relative mode, and linked with other software modules to get absolute addressing.

C Language Compilers. C language compilers are available that support the PSoC family of devices. The products allow you to create complete C programs for the PSoC family devices. The optimizing C compilers provide all of the features of C, tailored to the PSoC architecture. They come complete with embedded libraries providing port and bus operations, standard keypad and display support, and extended math functionality.

Debugger

PSoC Designer has a debug environment that provides hardware in-circuit emulation, allowing you to test the program in a physical system while providing an internal view of the PSoC device. Debugger commands allow you to read and program and read and write data memory, and read and write I/O registers. You can read and write CPU registers, set and clear breakpoints, and provide program run, halt, and step control. The debugger also allows you to create a trace buffer of registers and memory locations of interest.

Online Help System

The online help system displays online, context-sensitive help. Designed for procedural and quick reference, each functional subsystem has its own context-sensitive help. This system also provides tutorials and links to FAQs and an Online Support Forum to aid the designer.

In-Circuit Emulator

A low-cost, high-functionality In-Circuit Emulator (ICE) is available for development support. This hardware can program single devices.

The emulator consists of a base unit that connects to the PC using a USB port. The base unit is universal and operates with all PSoC devices. Emulation pods for each device family are available separately. The emulation pod takes the place of the PSoC device in the target board and performs full-speed (24 MHz) operation.

Designing with PSoC Designer

The development process for the PSoC[®] device differs from that of a traditional fixed function microprocessor. The configurable analog and digital hardware blocks give the PSoC architecture a unique flexibility that pays dividends in managing specification change during development and by lowering inventory costs. These configurable resources, called PSoC Blocks, have the ability to implement a wide variety of user-selectable functions. The PSoC development process is summarized in four steps:

1. Select [User Modules](#).
2. Configure user modules.
3. Organize and connect.
4. Generate, verify, and debug.

Select User Modules

PSoC Designer provides a library of prebuilt, pretested hardware peripheral components called “user modules.” User modules

make selecting and implementing peripheral devices, both analog and digital, simple.

Configure User Modules

Each user module that you select establishes the basic register settings that implement the selected function. They also provide parameters and properties that allow you to tailor their precise configuration to your particular application. For example, a pulse width modulator (PWM) User Module configures one or more digital PSoC blocks, one for each 8 bits of resolution. The user module parameters permit you to establish the pulse width and duty cycle. Configure the parameters and properties to correspond to your chosen application. Enter values directly or by selecting values from drop-down menus. All the user modules are documented in datasheets that may be viewed directly in PSoC Designer or on the Cypress website. These [user module datasheets](#) explain the internal operation of the user module and provide performance specifications. Each datasheet describes the use of each user module parameter, and other information you may need to successfully implement your design.

Organize and Connect

You build signal chains at the chip level by interconnecting user modules to each other and the I/O pins. You perform the selection, configuration, and routing so that you have complete control over all on-chip resources.

Generate, Verify, and Debug

When you are ready to test the hardware configuration or move on to developing code for the project, you perform the “Generate Configuration Files” step. This causes PSoC Designer to generate source code that automatically configures the device to your specification and provides the software for the system. The generated code provides application programming interfaces (APIs) with high-level functions to control and respond to hardware events at run time and interrupt service routines that you can adapt as needed.

A complete code development environment allows you to develop and customize your applications in either C, assembly language, or both.

The last step in the development process takes place inside PSoC Designer’s debugger (access by clicking the Connect icon). PSoC Designer downloads the HEX image to the ICE where it runs at full speed. PSoC Designer debugging capabilities rival those of systems costing many times more. In addition to traditional single-step, run-to-breakpoint and watch-variable features, the debug interface provides a large trace buffer and allows you to define complex breakpoint events that include monitoring address and data bus values, memory locations and external signals.

Pinouts

The CY8C29x66 PSoC device is available in a variety of packages which are listed and illustrated in the following tables. Every port pin (labeled with a "P") is capable of Digital I/O. However, V_{SS} , V_{DD} , SMP, and XRES are not capable of Digital I/O.

28-Pin Part Pinout

Table 2. 28-Pin Part Pinout (PDIP, SSOP, SOIC)

| Pin No. | Type | | Pin Name | Description |
|---------|---------|--------|----------|--|
| | Digital | Analog | | |
| 1 | I/O | I | P0[7] | Analog column mux input |
| 2 | I/O | I/O | P0[5] | Analog column mux input and column output |
| 3 | I/O | I/O | P0[3] | Analog column mux input and column output |
| 4 | I/O | I | P0[1] | Analog column mux input |
| 5 | I/O | | P2[7] | |
| 6 | I/O | | P2[5] | |
| 7 | I/O | I | P2[3] | Direct switched capacitor block input |
| 8 | I/O | I | P2[1] | Direct switched capacitor block input |
| 9 | Power | | SMP | Switch mode pump (SMP) connection to external components required |
| 10 | I/O | | P1[7] | I ² C serial clock (SCL) |
| 11 | I/O | | P1[5] | I ² C serial data (SDA) |
| 12 | I/O | | P1[3] | |
| 13 | I/O | | P1[1] | Crystal (XTALin), I ² C Serial Clock (SCL), ISSP-SCLK ^[5] |
| 14 | Power | | V_{SS} | Ground connection |
| 15 | I/O | | P1[0] | Crystal (XTALout), I ² C Serial Data (SDA), ISSP-SDATA ^[5] |
| 16 | I/O | | P1[2] | |
| 17 | I/O | | P1[4] | Optional external clock input (EXTCLK) |
| 18 | I/O | | P1[6] | |
| 19 | Input | | XRES | Active high external reset with internal pull-down |
| 20 | I/O | I | P2[0] | Direct switched capacitor block input |
| 21 | I/O | I | P2[2] | Direct switched capacitor block input |
| 22 | I/O | | P2[4] | External analog ground (AGND) |
| 23 | I/O | | P2[6] | External voltage reference (VREF) |
| 24 | I/O | I | P0[0] | Analog column mux input |
| 25 | I/O | I/O | P0[2] | Analog column mux input and column output |
| 26 | I/O | I/O | P0[4] | Analog column mux input and column output |
| 27 | I/O | I | P0[6] | Analog column mux input |
| 28 | Power | | V_{DD} | Supply voltage |

LEGEND: A = Analog, I = Input, and O = Output.

Figure 4. CY8C29466 28-Pin PSoC Device

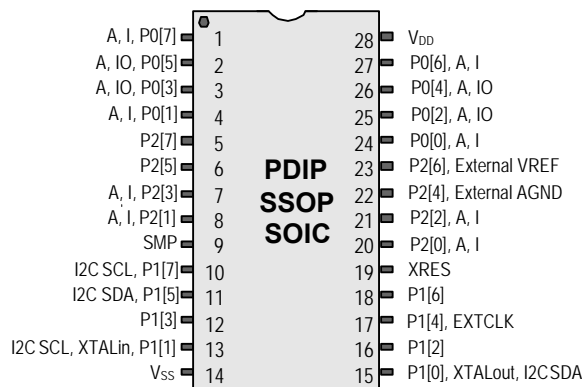

Note

5. These are the ISSP pins, which are not High Z at Power On Reset (POR). See the *PSoC Programmable System-on-Chip Technical Reference Manual* for details.

44-Pin Part Pinout

Table 3. 44-Pin Part Pinout (TQFP)

| Pin No. | Type | | Pin Name | Description |
|---------|---------|--------|-----------------|--|
| | Digital | Analog | | |
| 1 | I/O | | P2[5] | |
| 2 | I/O | I | P2[3] | Direct switched capacitor block input |
| 3 | I/O | I | P2[1] | Direct switched capacitor block input |
| 4 | I/O | | P4[7] | |
| 5 | I/O | | P4[5] | |
| 6 | I/O | | P4[3] | |
| 7 | I/O | | P4[1] | |
| 8 | Power | | SMP | Switch mode pump (SMP) connection to external components required |
| 9 | I/O | | P3[7] | |
| 10 | I/O | | P3[5] | |
| 11 | I/O | | P3[3] | |
| 12 | I/O | | P3[1] | |
| 13 | I/O | | P1[7] | I ² C SCL |
| 14 | I/O | | P1[5] | I ² C SDA |
| 15 | I/O | | P1[3] | |
| 16 | I/O | | P1[1] | Crystal (XTALin), I ² C SCL, ISSP-SCLK ^[6] |
| 17 | Power | | V _{SS} | Ground connection |
| 18 | I/O | | P1[0] | Crystal (XTALout), I ² C SDA, ISSP-SDATA ^[6] |
| 19 | I/O | | P1[2] | |
| 20 | I/O | | P1[4] | Optional EXTCLK |
| 21 | I/O | | P1[6] | |
| 22 | I/O | | P3[0] | |
| 23 | I/O | | P3[2] | |
| 24 | I/O | | P3[4] | |
| 25 | I/O | | P3[6] | |
| 26 | Input | | XRES | Active high external reset with internal pull-down |
| 27 | I/O | | P4[0] | |
| 28 | I/O | | P4[2] | |
| 29 | I/O | | P4[4] | |
| 30 | I/O | | P4[6] | |
| 31 | I/O | I | P2[0] | Direct switched capacitor block input |
| 32 | I/O | I | P2[2] | Direct switched capacitor block input |
| 33 | I/O | | P2[4] | External analog ground (AGND) |
| 34 | I/O | | P2[6] | External voltage reference (VREF) |
| 35 | I/O | I | P0[0] | Analog column mux input |
| 36 | I/O | I/O | P0[2] | Analog column mux input and column output |
| 37 | I/O | I/O | P0[4] | Analog column mux input and column output |
| 38 | I/O | I | P0[6] | Analog column mux input |
| 39 | Power | | V _{DD} | Supply voltage |
| 40 | I/O | I | P0[7] | Analog column mux input |
| 41 | I/O | I/O | P0[5] | Analog column mux input and column output |
| 42 | I/O | I/O | P0[3] | Analog column mux input and column output |
| 43 | I/O | I | P0[1] | Analog column mux input |
| 44 | I/O | | P2[7] | |

LEGEND: A = Analog, I = Input, and O = Output.

Note

6. These are the ISSP pins, which are not High Z at POR. See the *PSoC Programmable System-on-Chip Technical Reference Manual* for details.

Figure 5. CY8C29566 44-Pin PSoC Device

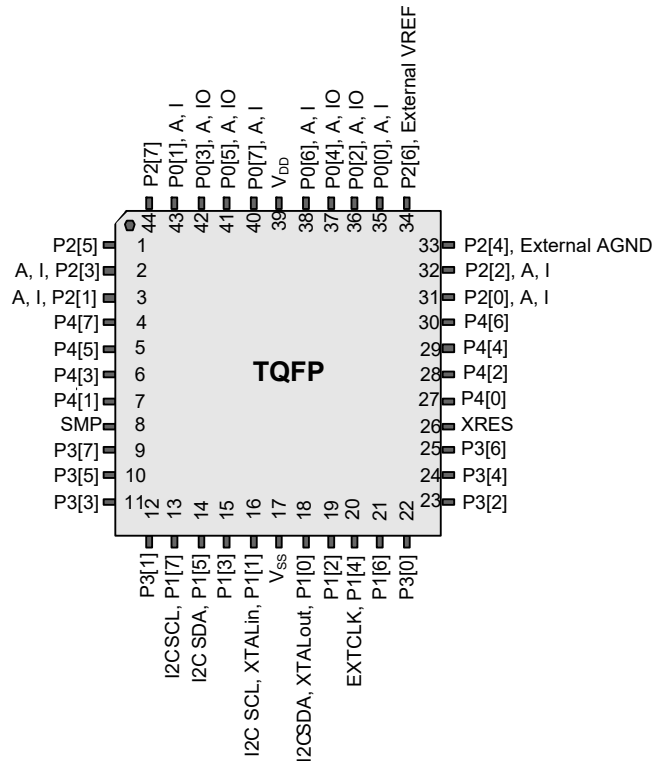

48-Pin Part Pinout

Table 4. 48-Pin Part Pinout (SSOP)

| Pin No. | Type | | Pin Name | Description |
|---------|---------|--------|-----------------|--|
| | Digital | Analog | | |
| 1 | I/O | I | P0[7] | Analog column mux input |
| 2 | I/O | I/O | P0[5] | Analog column mux input and column output |
| 3 | I/O | I/O | P0[3] | Analog column mux input and column output |
| 4 | I/O | I | P0[1] | Analog column mux input |
| 5 | I/O | | P2[7] | |
| 6 | I/O | | P2[5] | |
| 7 | I/O | I | P2[3] | Direct switched capacitor block input |
| 8 | I/O | I | P2[1] | Direct switched capacitor block input |
| 9 | I/O | | P4[7] | |
| 10 | I/O | | P4[5] | |
| 11 | I/O | | P4[3] | |
| 12 | I/O | | P4[1] | |
| 13 | Power | | SMP | Switch mode pump (SMP) connection to external components required |
| 14 | I/O | | P3[7] | |
| 15 | I/O | | P3[5] | |
| 16 | I/O | | P3[3] | |
| 17 | I/O | | P3[1] | |
| 18 | I/O | | P5[3] | |
| 19 | I/O | | P5[1] | |
| 20 | I/O | | P1[7] | I ² C SCL |
| 21 | I/O | | P1[5] | I ² C SDA |
| 22 | I/O | | P1[3] | |
| 23 | I/O | | P1[1] | Crystal (XTALin), I ² C SCL, ISSP-SCLK ^[7] |
| 24 | Power | | V _{SS} | Ground connection |
| 25 | I/O | | P1[0] | Crystal (XTALout), I ² C SDA, ISSP-SDATA ^[7] |
| 26 | I/O | | P1[2] | |
| 27 | I/O | | P1[4] | Optional EXTCLK |
| 28 | I/O | | P1[6] | |
| 29 | I/O | | P5[0] | |
| 30 | I/O | | P5[2] | |
| 31 | I/O | | P3[0] | |
| 32 | I/O | | P3[2] | |
| 33 | I/O | | P3[4] | |
| 34 | I/O | | P3[6] | |
| 35 | Input | | XRES | Active high external reset with internal pull-down |
| 36 | I/O | | P4[0] | |
| 37 | I/O | | P4[2] | |
| 38 | I/O | | P4[4] | |
| 39 | I/O | | P4[6] | |
| 40 | I/O | I | P2[0] | Direct switched capacitor block input |
| 41 | I/O | I | P2[2] | Direct switched capacitor block input |
| 42 | I/O | | P2[4] | External Analog Ground (AGND) |
| 43 | I/O | | P2[6] | External Voltage Reference (VREF) |
| 44 | I/O | I | P0[0] | Analog column mux input |
| 45 | I/O | I/O | P0[2] | Analog column mux input and column output |
| 46 | I/O | I/O | P0[4] | Analog column mux input and column output |
| 47 | I/O | I | P0[6] | Analog column mux input |
| 48 | Power | | V _{DD} | Supply voltage |

LEGEND: A = Analog, I = Input, and O = Output.

Note

7. These are the ISSP pins, which are not High Z at POR. See the *PSoC Programmable System-on-Chip Technical Reference Manual* for details.

Figure 6. CY8C29666 48-Pin PSoC Device

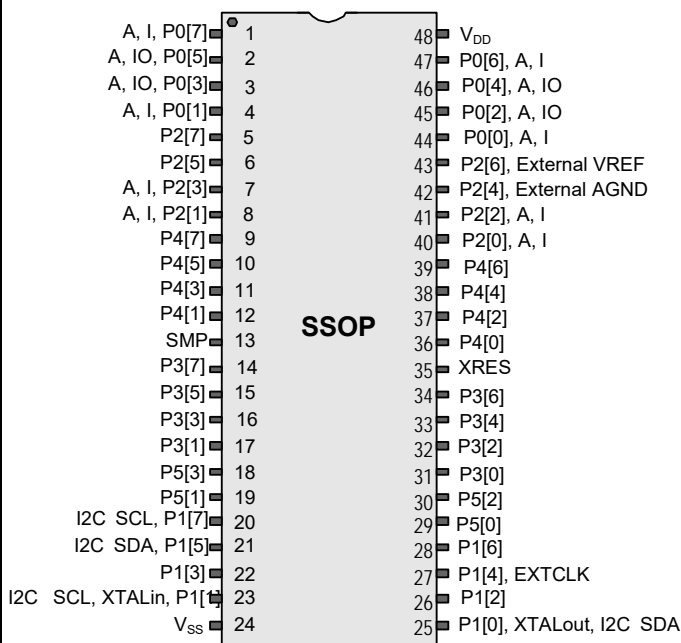

Table 5. 48-Pin Part Pinout (QFN) [9]

| Pin No. | Type | | Pin Name | Description |
|---------|---------|--------|-----------------|---|
| | Digital | Analog | | |
| 1 | I/O | I | P2[3] | Direct switched capacitor block input |
| 2 | I/O | I | P2[1] | Direct switched capacitor block input |
| 3 | I/O | | P4[7] | |
| 4 | I/O | | P4[5] | |
| 5 | I/O | | P4[3] | |
| 6 | I/O | | P4[1] | |
| 7 | Power | | SMP | Switch mode pump (SMP) connection to external components required |
| 8 | I/O | | P3[7] | |
| 9 | I/O | | P3[5] | |
| 10 | I/O | | P3[3] | |
| 11 | I/O | | P3[1] | |
| 12 | I/O | | P5[3] | |
| 13 | I/O | | P5[1] | |
| 14 | I/O | | P1[7] | I ² C SCL |
| 15 | I/O | | P1[5] | I ² C SDA |
| 16 | I/O | | P1[3] | |
| 17 | I/O | | P1[1] | Crystal (XTALin), I ² C SCL, ISSP-SCLK ⁸ |
| 18 | Power | | V _{SS} | Ground connection |
| 19 | I/O | | P1[0] | Crystal (XTALout), I ² C SDA, ISSP-SDATA ⁸ |
| 20 | I/O | | P1[2] | |
| 21 | I/O | | P1[4] | Optional EXTCLK |
| 22 | I/O | | P1[6] | |
| 23 | I/O | | P5[0] | |
| 24 | I/O | | P5[2] | |
| 25 | I/O | | P3[0] | |
| 26 | I/O | | P3[2] | |
| 27 | I/O | | P3[4] | |
| 28 | I/O | | P3[6] | |
| 29 | Input | | XRES | Active high external reset with internal pull-down |
| 30 | I/O | | P4[0] | |
| 31 | I/O | | P4[2] | |
| 32 | I/O | | P4[4] | |
| 33 | I/O | | P4[6] | |
| 34 | I/O | I | P2[0] | Direct switched capacitor block input |
| 35 | I/O | I | P2[2] | Direct switched capacitor block input |
| 36 | I/O | | P2[4] | External analog ground (AGND) |
| 37 | I/O | | P2[6] | External voltage reference (VREF) |
| 38 | I/O | I | P0[0] | Analog column mux input |
| 39 | I/O | I/O | P0[2] | Analog column mux input and column output |
| 40 | I/O | I/O | P0[4] | Analog column mux input and column output |
| 41 | I/O | I | P0[6] | Analog column mux input |
| 42 | Power | | V _{DD} | Supply voltage |
| 43 | I/O | I | P0[7] | Analog column mux input |
| 44 | I/O | I/O | P0[5] | Analog column mux input and column output |
| 45 | I/O | I/O | P0[3] | Analog column mux input and column output |
| 46 | I/O | I | P0[1] | Analog column mux input |
| 47 | I/O | | P2[7] | |
| 48 | I/O | | P2[5] | |

LEGEND: A = Analog, I = Input, and O = Output.

Notes

- These are the ISSP pins, which are not High Z at POR. See the *PSoC Programmable System-on-Chip Technical Reference Manual* for details.
- The QFN package has a center pad that must be connected to ground (V_{SS}).

Figure 7. CY8C29666 48-Pin PSoC Device

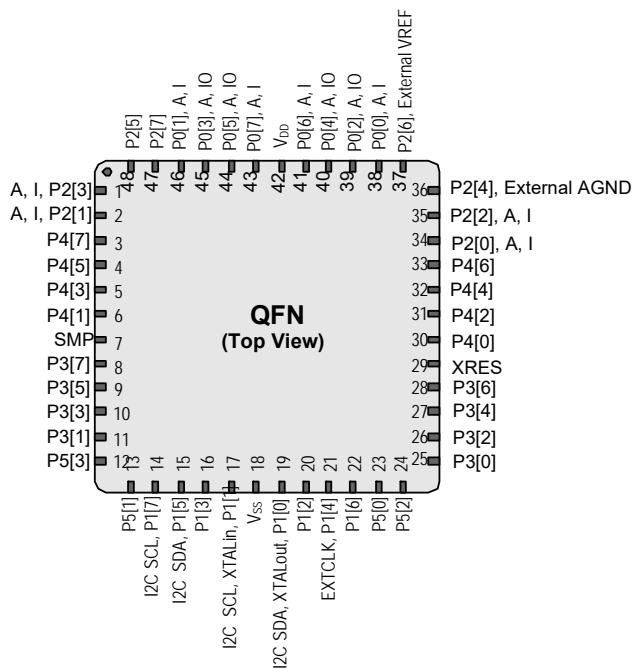

100-Pin Part Pinout

Table 6. 100-Pin Part Pinout (TQFP)

| Pin No. | Type | | Name | Description | Pin No. | Type | | Name | Description |
|---------|---------|--------|-----------------|--|---------|---------|--------|-----------------|--|
| | Digital | Analog | | | | Digital | Analog | | |
| 1 | | | NC | No connection. Pin must be left floating | 51 | | | NC | No connection. Pin must be left floating |
| 2 | | | NC | No connection. Pin must be left floating | 52 | I/O | | P5[0] | |
| 3 | I/O | I | P0[1] | Analog column mux input | 53 | I/O | | P5[2] | |
| 4 | I/O | | P2[7] | | 54 | I/O | | P5[4] | |
| 5 | I/O | | P2[5] | | 55 | I/O | | P5[6] | |
| 6 | I/O | I | P2[3] | Direct switched capacitor block input | 56 | I/O | | P3[0] | |
| 7 | I/O | I | P2[1] | Direct switched capacitor block input | 57 | I/O | | P3[2] | |
| 8 | I/O | | P4[7] | | 58 | I/O | | P3[4] | |
| 9 | I/O | | P4[5] | | 59 | I/O | | P3[6] | |
| 10 | I/O | | P4[3] | | 60 | | | NC | No connection. Pin must be left floating |
| 11 | I/O | | P4[1] | | 61 | | | NC | No connection. Pin must be left floating |
| 12 | | | NC | No connection. Pin must be left floating | 62 | | Input | XRES | Active high external reset with internal pull-down |
| 13 | | | NC | No connection. Pin must be left floating | 63 | I/O | | P4[0] | |
| 14 | | Power | SMP | Switch mode pump (SMP) connection to external components required | 64 | I/O | | P4[2] | |
| 15 | | Power | V _{SS} | Ground connection ^[10] | 65 | | Power | V _{SS} | Ground connection ^[10] |
| 16 | I/O | | P3[7] | | 66 | I/O | | P4[4] | |
| 17 | I/O | | P3[5] | | 67 | I/O | | P4[6] | |
| 18 | I/O | | P3[3] | | 68 | I/O | I | P2[0] | Direct switched capacitor block input |
| 19 | I/O | | P3[1] | | 69 | I/O | I | P2[2] | Direct switched capacitor block input |
| 20 | I/O | | P5[7] | | 70 | I/O | | P2[4] | External Analog Ground (AGND) |
| 21 | I/O | | P5[5] | | 71 | | | NC | No connection. Pin must be left floating |
| 22 | I/O | | P5[3] | | 72 | I/O | | P2[6] | External Voltage Reference (VREF) |
| 23 | I/O | | P5[1] | | 73 | | | NC | No connection. Pin must be left floating |
| 24 | I/O | | P1[7] | I ² C SCL | 74 | I/O | I | P0[0] | Analog column mux input |
| 25 | | | NC | No connection. Pin must be left floating | 75 | | | NC | No connection. Pin must be left floating |
| 26 | | | NC | No connection. Pin must be left floating | 76 | | | NC | No connection. Pin must be left floating |
| 27 | | | NC | No connection. Pin must be left floating | 77 | I/O | I/O | P0[2] | Analog column mux input and column output |
| 28 | I/O | | P1[5] | I ² C SDA | 78 | | | NC | No connection. Pin must be left floating |
| 29 | I/O | | P1[3] | | 79 | I/O | I/O | P0[4] | Analog column mux input and column output |
| 30 | I/O | | P1[1] | Crystal (XTAL _{in}), I ² C Serial Clock (SCL), ISSP-SCLK ^[11] | 80 | | | NC | No connection. Pin must be left floating |
| 31 | | | NC | No connection. Pin must be left floating | 81 | I/O | I | P0[6] | Analog column mux input |
| 32 | | Power | V _{DD} | Supply voltage | 82 | | Power | V _{DD} | Supply voltage |
| 33 | | | NC | No connection. Pin must be left floating | 83 | | Power | V _{DD} | Supply voltage |
| 34 | | Power | V _{SS} | Ground connection ^[10] | 84 | | Power | V _{SS} | Ground connection ^[10] |
| 35 | | | NC | No connection. Pin must be left floating | 85 | | Power | V _{SS} | Ground connection ^[10] |
| 36 | I/O | | P7[7] | | 86 | I/O | | P6[0] | |
| 37 | I/O | | P7[6] | | 87 | I/O | | P6[1] | |
| 38 | I/O | | P7[5] | | 88 | I/O | | P6[2] | |
| 39 | I/O | | P7[4] | | 89 | I/O | | P6[3] | |
| 40 | I/O | | P7[3] | | 90 | I/O | | P6[4] | |
| 41 | I/O | | P7[2] | | 91 | I/O | | P6[5] | |
| 42 | I/O | | P7[1] | | 92 | I/O | | P6[6] | |
| 43 | I/O | | P7[0] | | 93 | I/O | | P6[7] | |
| 44 | I/O | | P1[0] | Crystal (XTAL _{out}), I ² C Serial Data (SDA), ISSP-SDATA ^[11] | 94 | | | NC | No connection. Pin must be left floating |
| 45 | I/O | | P1[2] | | 95 | I/O | I | P0[7] | Analog column mux input |
| 46 | I/O | | P1[4] | Optional EXTCLK | 96 | | | NC | No connection. Pin must be left floating |
| 47 | I/O | | P1[6] | | 97 | I/O | I/O | P0[5] | Analog column mux input and column output |
| 48 | | | NC | No connection. Pin must be left floating | 98 | | | NC | No connection. Pin must be left floating |
| 49 | | | NC | No connection. Pin must be left floating | 99 | I/O | I/O | P0[3] | Analog column mux input and column output |
| 50 | | | NC | No connection. Pin must be left floating | 100 | | | NC | No connection. Pin must be left floating |

LEGEND: A = Analog, I = Input, and O = Output.

Notes

10. All V_{SS} pins should be brought out to one common GND plane.

11. These are the ISSP pins, which are not High Z at POR. See the *PSoC Programmable System-on-Chip Technical Reference Manual* for details.

Figure 8. CY8C29866 100-Pin PSoC Device

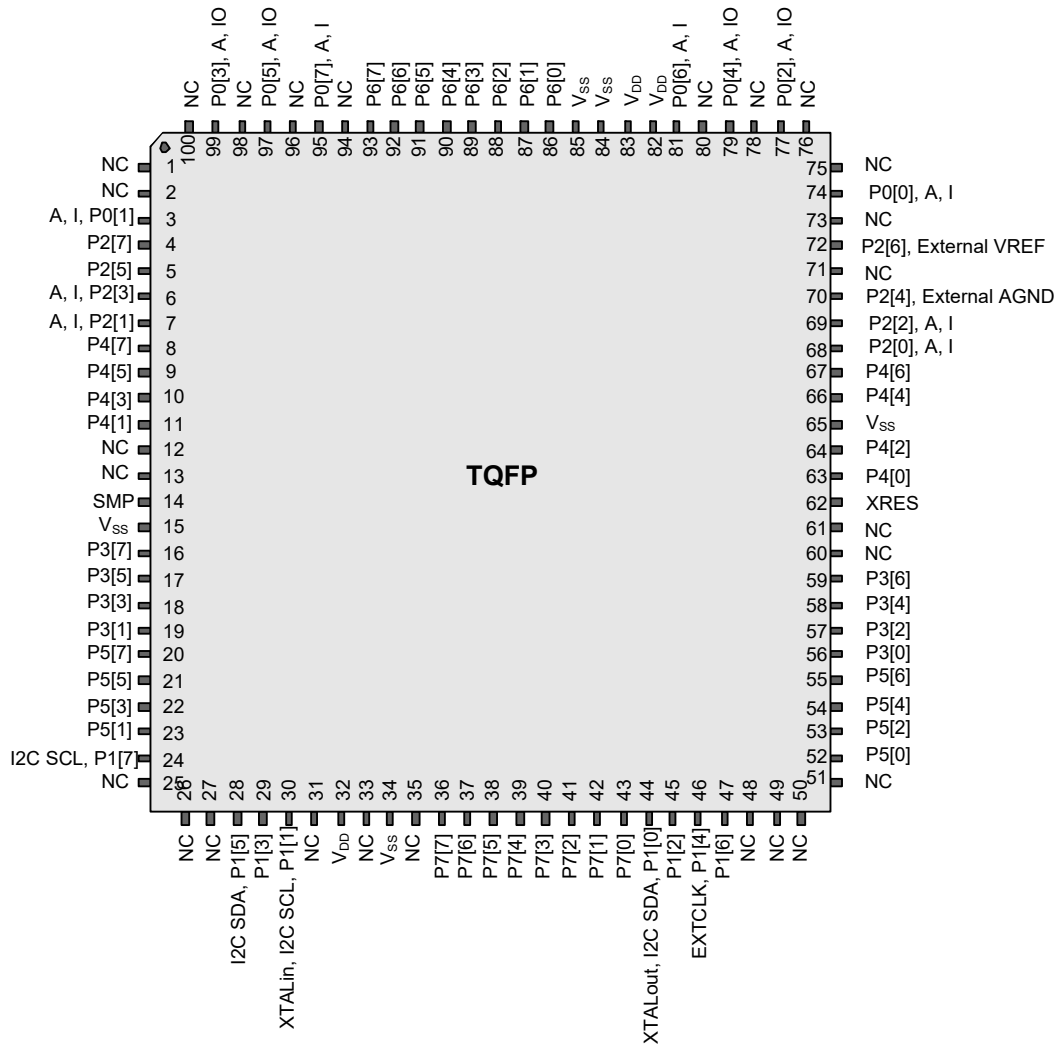

100-Pin Part Pinout (On-Chip Debug)

The 100-pin TQFP part is for the CY8C29000 On-Chip Debug (OCD) PSoC device.

Note OCD parts are only used for in-circuit debugging. OCD parts are NOT available for production.

Table 7. 100-Pin OCD Part Pinout (TQFP)

| Pin No. | Digital | Analog | Name | Description | Pin No. | Digital | Analog | Name | Description |
|---------|---------|--------|-----------------------|---|---------|---------|--------|-----------------|---|
| 1 | | | NC | No internal connection | 51 | | | NC | No internal connection |
| 2 | | | NC | No internal connection | 52 | I/O | | P5[0] | |
| 3 | I/O | I | P0[1] | Analog column mux input | 53 | I/O | | P5[2] | |
| 4 | I/O | | P2[7] | | 54 | I/O | | P5[4] | |
| 5 | I/O | | P2[5] | | 55 | I/O | | P5[6] | |
| 6 | I/O | I | P2[3] | Direct switched capacitor block input | 56 | I/O | | P3[0] | |
| 7 | I/O | I | P2[1] | Direct switched capacitor block input | 57 | I/O | | P3[2] | |
| 8 | I/O | | P4[7] | | 58 | I/O | | P3[4] | |
| 9 | I/O | | P4[5] | | 59 | I/O | | P3[6] | |
| 10 | I/O | | P4[3] | | 60 | | | HCLK | OCD high speed clock output |
| 11 | I/O | | P4[1] | | 61 | | | CCLK | OCD CPU clock output |
| 12 | | | OCDE | OCD even data I/O | 62 | Input | | XRES | Active high pin reset with internal pull-down |
| 13 | | | OCDO | OCD odd data output | 63 | I/O | | P4[0] | |
| 14 | Power | | SMP | Switch Mode Pump (SMP) connection to required external components | 64 | I/O | | P4[2] | |
| 15 | Power | | V _{SS} | Ground connection ^[12] | 65 | Power | | V _{SS} | Ground connection ^[12] |
| 16 | I/O | | P3[7] | | 66 | I/O | | P4[4] | |
| 17 | I/O | | P3[5] | | 67 | I/O | | P4[6] | |
| 18 | I/O | | P3[3] | | 68 | I/O | I | P2[0] | Direct switched capacitor block input |
| 19 | I/O | | P3[1] | | 69 | I/O | I | P2[2] | Direct switched capacitor block input |
| 20 | I/O | | P5[7] | | 70 | I/O | | P2[4] | External Analog Ground (AGND) input |
| 21 | I/O | | P5[5] | | 71 | | | NC | No internal connection |
| 22 | I/O | | P5[3] | | 72 | I/O | | P2[6] | External Voltage Reference (VREF) input |
| 23 | I/O | | P5[1] | | 73 | | | NC | No internal connection |
| 24 | I/O | | P1[7] | I ² C SCL | 74 | I/O | I | P0[0] | Analog column mux input |
| 25 | | | NC | No internal connection | 75 | | | NC | No internal connection |
| 26 | | | NC | No internal connection | 76 | | | NC | No internal connection |
| 27 | | | NC | No internal connection | 77 | I/O | I/O | P0[2] | Analog column mux input and column output |
| 28 | I/O | | P1[5] | I ² C SDA | 78 | | | NC | No internal connection |
| 29 | I/O | | P1[3] | I _{FMTEST} | 79 | I/O | I/O | P0[4] | Analog column mux input and column output, V _{REF} |
| 30 | I/O | | P1[1] ^[13] | Crystal (XTALin), I ² C SCL, TC SCLK. | 80 | | | NC | No internal connection |
| 31 | | | NC | No internal connection | 81 | I/O | I | P0[6] | Analog column mux input |
| 32 | Power | | V _{DD} | Supply voltage | 82 | Power | | V _{DD} | Supply voltage |
| 33 | | | NC | No internal connection | 83 | Power | | V _{DD} | Supply voltage |
| 34 | Power | | V _{SS} | Ground connection ^[12] | 84 | Power | | V _{SS} | Ground connection ^[12] |
| 35 | | | NC | No internal connection | 85 | Power | | V _{SS} | Ground connection ^[12] |
| 36 | I/O | | P7[7] | | 86 | I/O | | P6[0] | |
| 37 | I/O | | P7[6] | | 87 | I/O | | P6[1] | |
| 38 | I/O | | P7[5] | | 88 | I/O | | P6[2] | |
| 39 | I/O | | P7[4] | | 89 | I/O | | P6[3] | |
| 40 | I/O | | P7[3] | | 90 | I/O | | P6[4] | |
| 41 | I/O | | P7[2] | | 91 | I/O | | P6[5] | |
| 42 | I/O | | P7[1] | | 92 | I/O | | P6[6] | |
| 43 | I/O | | P7[0] | | 93 | I/O | | P6[7] | |
| 44 | I/O | | P1[0]* | Crystal (XTALout), I ² C SDA, TC SDA | 94 | | | NC | No internal connection |
| 45 | I/O | | P1[2] | V _{FMTEST} | 95 | I/O | I | P0[7] | Analog column mux input |
| 46 | I/O | | P1[4] | Optional External Clock Input (EXTCLK) | 96 | | | NC | No internal connection |
| 47 | I/O | | P1[6] | | 97 | I/O | I/O | P0[5] | Analog column mux input and column output |
| 48 | | | NC | No internal connection | 98 | | | NC | No internal connection |
| 49 | | | NC | No internal connection | 99 | I/O | I/O | P0[3] | Analog column mux input and column output |
| 50 | | | NC | No internal connection | 100 | | | NC | No internal connection |

LEGEND A = Analog, I = Input, O = Output, NC = No connection. Pin must be left floating, TC/TM: Test.

Notes

- 12. All V_{SS} pins should be brought out to one common GND plane.
- 13. ISSP pin which is not High-Z at POR.

Figure 9. CY8C29000 OCD (Not for Production)

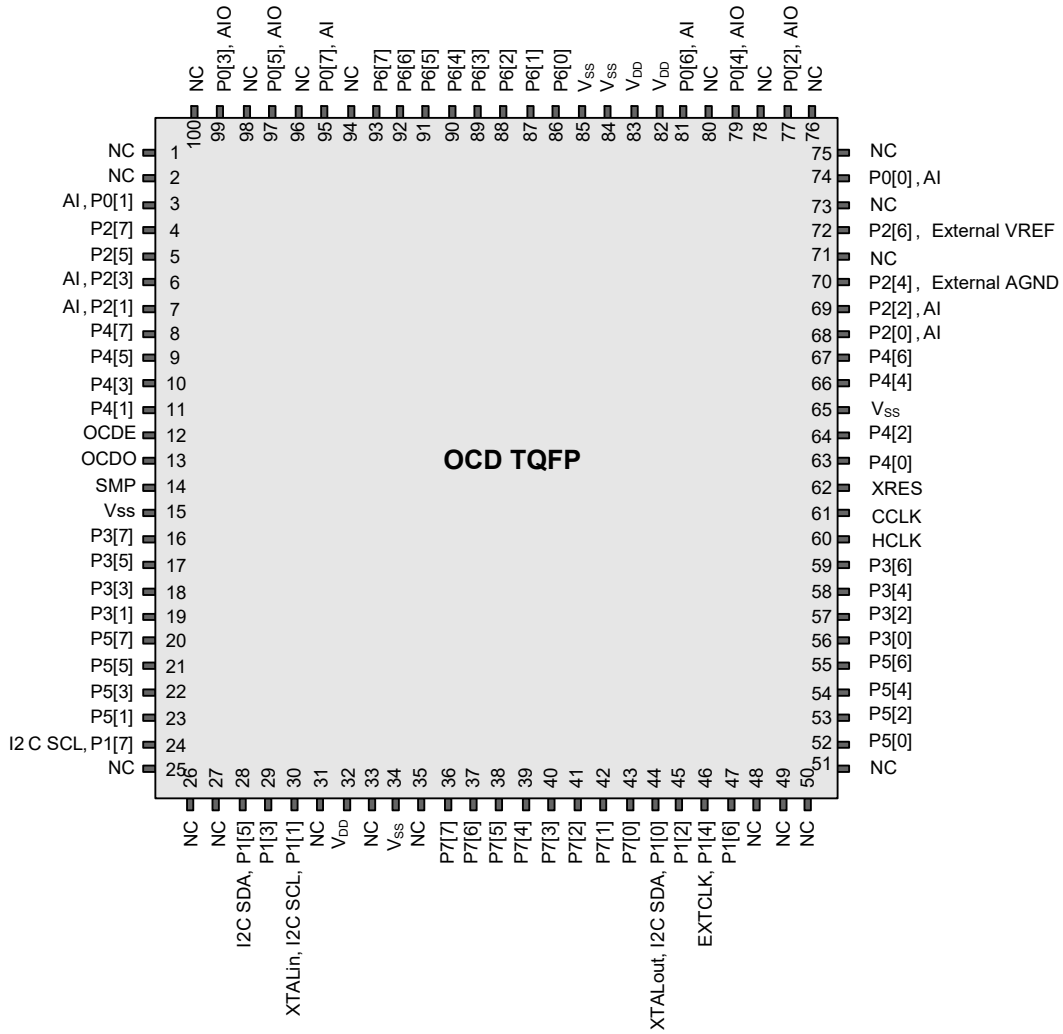

Register Reference

This section lists the registers of the CY8C29x66 PSoC device. For detailed register information, refer to the *PSoC Programmable System-on-Chip Technical Reference Manual*.

Register Conventions

The register conventions specific to this section are listed in [Table 8](#).

Table 8. Register Conventions

| Convention | Description |
|------------|------------------------------|
| R | Read register or bit(s) |
| W | Write register or bit(s) |
| L | Logical register or bit(s) |
| C | Clearable register or bit(s) |
| # | Access is bit specific |

Register Mapping Tables

The PSoC device has a total register address space of 512 bytes. The register space is referred to as I/O space and is divided into two banks. The XO1 bit in the flag register (CPU_F) determines which bank the user is currently in. When the XO1 bit is set the user is in Bank 1.

Note In the register mapping tables, blank fields are reserved and should not be accessed.

Table 9. Register Map Bank 0 Table: User Space

| Name | Addr (0,Hex) | Access | Name | Addr (0,Hex) | Access | Name | Addr (0,Hex) | Access | Name | Addr (0,Hex) | Access |
|----------|--------------|--------|----------|--------------|--------|----------|--------------|--------|----------|--------------|--------|
| PRT0DR | 00 | RW | DBB20DR0 | 40 | # | ASC10CR0 | 80 | RW | RD12RI | C0 | RW |
| PRT0IE | 01 | RW | DBB20DR1 | 41 | W | ASC10CR1 | 81 | RW | RD12SYN | C1 | RW |
| PRT0GS | 02 | RW | DBB20DR2 | 42 | RW | ASC10CR2 | 82 | RW | RD12IS | C2 | RW |
| PRT0DM2 | 03 | RW | DBB20CR0 | 43 | # | ASC10CR3 | 83 | RW | RD12LT0 | C3 | RW |
| PRT1DR | 04 | RW | DBB21DR0 | 44 | # | ASD11CR0 | 84 | RW | RD12LT1 | C4 | RW |
| PRT1IE | 05 | RW | DBB21DR1 | 45 | W | ASD11CR1 | 85 | RW | RD12RO0 | C5 | RW |
| PRT1GS | 06 | RW | DBB21DR2 | 46 | RW | ASD11CR2 | 86 | RW | RD12RO1 | C6 | RW |
| PRT1DM2 | 07 | RW | DBB21CR0 | 47 | # | ASD11CR3 | 87 | RW | | C7 | |
| PRT2DR | 08 | RW | DCB22DR0 | 48 | # | ASC12CR0 | 88 | RW | RD13RI | C8 | RW |
| PRT2IE | 09 | RW | DCB22DR1 | 49 | W | ASC12CR1 | 89 | RW | RD13SYN | C9 | RW |
| PRT2GS | 0A | RW | DCB22DR2 | 4A | RW | ASC12CR2 | 8A | RW | RD13IS | CA | RW |
| PRT2DM2 | 0B | RW | DCB22CR0 | 4B | # | ASC12CR3 | 8B | RW | RD13LT0 | CB | RW |
| PRT3DR | 0C | RW | DCB23DR0 | 4C | # | ASD13CR0 | 8C | RW | RD13LT1 | CC | RW |
| PRT3IE | 0D | RW | DCB23DR1 | 4D | W | ASD13CR1 | 8D | RW | RD13RO0 | CD | RW |
| PRT3GS | 0E | RW | DCB23DR2 | 4E | RW | ASD13CR2 | 8E | RW | RD13RO1 | CE | RW |
| PRT3DM2 | 0F | RW | DCB23CR0 | 4F | # | ASD13CR3 | 8F | RW | | CF | |
| PRT4DR | 10 | RW | DBB30DR0 | 50 | # | ASD20CR0 | 90 | RW | CUR_PP | D0 | RW |
| PRT4IE | 11 | RW | DBB30DR1 | 51 | W | ASD20CR1 | 91 | RW | STK_PP | D1 | RW |
| PRT4GS | 12 | RW | DBB30DR2 | 52 | RW | ASD20CR2 | 92 | RW | | D2 | |
| PRT4DM2 | 13 | RW | DBB30CR0 | 53 | # | ASD20CR3 | 93 | RW | IDX_PP | D3 | RW |
| PRT5DR | 14 | RW | DBB31DR0 | 54 | # | ASC21CR0 | 94 | RW | MVR_PP | D4 | RW |
| PRT5IE | 15 | RW | DBB31DR1 | 55 | W | ASC21CR1 | 95 | RW | MVW_PP | D5 | RW |
| PRT5GS | 16 | RW | DBB31DR2 | 56 | RW | ASC21CR2 | 96 | RW | I2C_CFG | D6 | RW |
| PRT5DM2 | 17 | RW | DBB31CR0 | 57 | # | ASC21CR3 | 97 | RW | I2C_SCR | D7 | # |
| PRT6DR | 18 | RW | DCB32DR0 | 58 | # | ASD22CR0 | 98 | RW | I2C_DR | D8 | RW |
| PRT6IE | 19 | RW | DCB32DR1 | 59 | W | ASD22CR1 | 99 | RW | I2C_MSCR | D9 | # |
| PRT6GS | 1A | RW | DCB32DR2 | 5A | RW | ASD22CR2 | 9A | RW | INT_CLR0 | DA | RW |
| PRT6DM2 | 1B | RW | DCB32CR0 | 5B | # | ASD22CR3 | 9B | RW | INT_CLR1 | DB | RW |
| PRT7DR | 1C | RW | DCB33DR0 | 5C | # | ASC23CR0 | 9C | RW | INT_CLR2 | DC | RW |
| PRT7IE | 1D | RW | DCB33DR1 | 5D | W | ASC23CR1 | 9D | RW | INT_CLR3 | DD | RW |
| PRT7GS | 1E | RW | DCB33DR2 | 5E | RW | ASC23CR2 | 9E | RW | INT_MSK3 | DE | RW |
| PRT7DM2 | 1F | RW | DCB33CR0 | 5F | # | ASC23CR3 | 9F | RW | INT_MSK2 | DF | RW |
| DBB00DR0 | 20 | # | AMX_IN | 60 | RW | | A0 | | INT_MSK0 | E0 | RW |
| DBB00DR1 | 21 | W | | 61 | | | A1 | | INT_MSK1 | E1 | RW |
| DBB00DR2 | 22 | RW | | 62 | | | A2 | | INT_VC | E2 | RC |
| DBB00CR0 | 23 | # | ARF_CR | 63 | RW | | A3 | | RES_WDT | E3 | W |
| DBB01DR0 | 24 | # | CMP_CR0 | 64 | # | | A4 | | DEC_DH | E4 | RC |
| DBB01DR1 | 25 | W | ASY_CR | 65 | # | | A5 | | DEC_DL | E5 | RC |
| DBB01DR2 | 26 | RW | CMP_CR1 | 66 | RW | | A6 | | DEC_CR0 | E6 | RW |
| DBB01CR0 | 27 | # | | 67 | | | A7 | | DEC_CR1 | E7 | RW |
| DCB02DR0 | 28 | # | | 68 | | MUL1_X | A8 | W | MULO_X | E8 | W |
| DCB02DR1 | 29 | W | | 69 | | MUL1_Y | A9 | W | MULO_Y | E9 | W |
| DCB02DR2 | 2A | RW | | 6A | | MUL1_DH | AA | R | MULO_DH | EA | R |
| DCB02CR0 | 2B | # | | 6B | | MUL1_DL | AB | R | MULO_DL | EB | R |
| DCB03DR0 | 2C | # | TMP_DR0 | 6C | RW | ACC1_DR1 | AC | RW | ACC0_DR1 | EC | RW |
| DCB03DR1 | 2D | W | TMP_DR1 | 6D | RW | ACC1_DR0 | AD | RW | ACC0_DR0 | ED | RW |
| DCB03DR2 | 2E | RW | TMP_DR2 | 6E | RW | ACC1_DR3 | AE | RW | ACC0_DR3 | EE | RW |
| DCB03CR0 | 2F | # | TMP_DR3 | 6F | RW | ACC1_DR2 | AF | RW | ACC0_DR2 | EF | RW |
| DBB10DR0 | 30 | # | ACB00CR3 | 70 | RW | RD10RI | B0 | RW | | F0 | |
| DBB10DR1 | 31 | W | ACB00CR0 | 71 | RW | RD10SYN | B1 | RW | | F1 | |
| DBB10DR2 | 32 | RW | ACB00CR1 | 72 | RW | RD10IS | B2 | RW | | F2 | |
| DBB10CR0 | 33 | # | ACB00CR2 | 73 | RW | RD10LT0 | B3 | RW | | F3 | |
| DBB11DR0 | 34 | # | ACB01CR3 | 74 | RW | RD10LT1 | B4 | RW | | F4 | |
| DBB11DR1 | 35 | W | ACB01CR0 | 75 | RW | RD10RO0 | B5 | RW | | F5 | |
| DBB11DR2 | 36 | RW | ACB01CR1 | 76 | RW | RD10RO1 | B6 | RW | | F6 | |
| DBB11CR0 | 37 | # | ACB01CR2 | 77 | RW | | B7 | | CPU_F | F7 | RL |
| DCB12DR0 | 38 | # | ACB02CR3 | 78 | RW | RD11RI | B8 | RW | | F8 | |
| DCB12DR1 | 39 | W | ACB02CR0 | 79 | RW | RD11SYN | B9 | RW | | F9 | |
| DCB12DR2 | 3A | RW | ACB02CR1 | 7A | RW | RD11IS | BA | RW | | FA | |
| DCB12CR0 | 3B | # | ACB02CR2 | 7B | RW | RD11LT0 | BB | RW | | FB | |
| DCB13DR0 | 3C | # | ACB03CR3 | 7C | RW | RD11LT1 | BC | RW | | FC | |
| DCB13DR1 | 3D | W | ACB03CR0 | 7D | RW | RD11RO0 | BD | RW | | FD | |
| DCB13DR2 | 3E | RW | ACB03CR1 | 7E | RW | RD11RO1 | BE | RW | CPU_SCR1 | FE | # |
| DCB13CR0 | 3F | # | ACB03CR2 | 7F | RW | | BF | | CPU_SCR0 | FF | # |

Blank fields are Reserved and should not be accessed.

Access is bit specific.

Table 10. Register Map Bank 1 Table: Configuration Space

| Name | Addr (1,Hex) | Access | Name | Addr (1,Hex) | Access | Name | Addr (1,Hex) | Access | Name | Addr (1,Hex) | Access |
|---------|--------------|--------|----------|--------------|--------|----------|--------------|--------|-----------|--------------|--------|
| PRT0DM0 | 00 | RW | DBB20FN | 40 | RW | ASC10CR0 | 80 | RW | RDI2RI | C0 | RW |
| PRT0DM1 | 01 | RW | DBB20IN | 41 | RW | ASC10CR1 | 81 | RW | RDI2SYN | C1 | RW |
| PRT0IC0 | 02 | RW | DBB20OU | 42 | RW | ASC10CR2 | 82 | RW | RDI2IS | C2 | RW |
| PRT0IC1 | 03 | RW | | 43 | | ASC10CR3 | 83 | RW | RDI2LT0 | C3 | RW |
| PRT1DM0 | 04 | RW | DBB21FN | 44 | RW | ASD11CR0 | 84 | RW | RDI2LT1 | C4 | RW |
| PRT1DM1 | 05 | RW | DBB21IN | 45 | RW | ASD11CR1 | 85 | RW | RDI2RO0 | C5 | RW |
| PRT1IC0 | 06 | RW | DBB21OU | 46 | RW | ASD11CR2 | 86 | RW | RDI2RO1 | C6 | RW |
| PRT1IC1 | 07 | RW | | 47 | | ASD11CR3 | 87 | RW | | C7 | |
| PRT2DM0 | 08 | RW | DCB22FN | 48 | RW | ASC12CR0 | 88 | RW | RDI3RI | C8 | RW |
| PRT2DM1 | 09 | RW | DCB22IN | 49 | RW | ASC12CR1 | 89 | RW | RDI3SYN | C9 | RW |
| PRT2IC0 | 0A | RW | DCB22OU | 4A | RW | ASC12CR2 | 8A | RW | RDI3IS | CA | RW |
| PRT2IC1 | 0B | RW | | 4B | | ASC12CR3 | 8B | RW | RDI3LT0 | CB | RW |
| PRT3DM0 | 0C | RW | DCB23FN | 4C | RW | ASD13CR0 | 8C | RW | RDI3LT1 | CC | RW |
| PRT3DM1 | 0D | RW | DCB23IN | 4D | RW | ASD13CR1 | 8D | RW | RDI3RO0 | CD | RW |
| PRT3IC0 | 0E | RW | DCB23OU | 4E | RW | ASD13CR2 | 8E | RW | RDI3RO1 | CE | RW |
| PRT3IC1 | 0F | RW | | 4F | | ASD13CR3 | 8F | RW | | CF | |
| PRT4DM0 | 10 | RW | DBB30FN | 50 | RW | ASD20CR0 | 90 | RW | GDI_O_IN | D0 | RW |
| PRT4DM1 | 11 | RW | DBB30IN | 51 | RW | ASD20CR1 | 91 | RW | GDI_E_IN | D1 | RW |
| PRT4IC0 | 12 | RW | DBB30OU | 52 | RW | ASD20CR2 | 92 | RW | GDI_O_OU | D2 | RW |
| PRT4IC1 | 13 | RW | | 53 | | ASD20CR3 | 93 | RW | GDI_E_OU | D3 | RW |
| PRT5DM0 | 14 | RW | DBB31FN | 54 | RW | ASC21CR0 | 94 | RW | | D4 | |
| PRT5DM1 | 15 | RW | DBB31IN | 55 | RW | ASC21CR1 | 95 | RW | | D5 | |
| PRT5IC0 | 16 | RW | DBB31OU | 56 | RW | ASC21CR2 | 96 | RW | | D6 | |
| PRT5IC1 | 17 | RW | | 57 | | ASC21CR3 | 97 | RW | | D7 | |
| PRT6DM0 | 18 | RW | DCB32FN | 58 | RW | ASD22CR0 | 98 | RW | | D8 | |
| PRT6DM1 | 19 | RW | DCB32IN | 59 | RW | ASD22CR1 | 99 | RW | | D9 | |
| PRT6IC0 | 1A | RW | DCB32OU | 5A | RW | ASD22CR2 | 9A | RW | | DA | |
| PRT6IC1 | 1B | RW | | 5B | | ASD22CR3 | 9B | RW | | DB | |
| PRT7DM0 | 1C | RW | DCB33FN | 5C | RW | ASC23CR0 | 9C | RW | | DC | |
| PRT7DM1 | 1D | RW | DCB33IN | 5D | RW | ASC23CR1 | 9D | RW | OSC_GO_EN | DD | RW |
| PRT7IC0 | 1E | RW | DCB33OU | 5E | RW | ASC23CR2 | 9E | RW | OSC_CR4 | DE | RW |
| PRT7IC1 | 1F | RW | | 5F | | ASC23CR3 | 9F | RW | OSC_CR3 | DF | RW |
| DBB00FN | 20 | RW | CLK_CR0 | 60 | RW | | A0 | | OSC_CR0 | E0 | RW |
| DBB00IN | 21 | RW | CLK_CR1 | 61 | RW | | A1 | | OSC_CR1 | E1 | RW |
| DBB00OU | 22 | RW | ABF_CR0 | 62 | RW | | A2 | | OSC_CR2 | E2 | RW |
| | 23 | | AMD_CR0 | 63 | RW | | A3 | | VLT_CR | E3 | RW |
| DBB01FN | 24 | RW | | 64 | | | A4 | | VLT_CMP | E4 | R |
| DBB01IN | 25 | RW | | 65 | | | A5 | | | E5 | |
| DBB01OU | 26 | RW | AMD_CR1 | 66 | RW | | A6 | | | E6 | |
| | 27 | | ALT_CR0 | 67 | RW | | A7 | | DEC_CR2 | E7 | RW |
| DCB02FN | 28 | RW | ALT_CR1 | 68 | RW | | A8 | | IMO_TR | E8 | W |
| DCB02IN | 29 | RW | CLK_CR2 | 69 | RW | | A9 | | ILO_TR | E9 | W |
| DCB02OU | 2A | RW | | 6A | | | AA | | BDG_TR | EA | RW |
| | 2B | | | 6B | | | AB | | ECO_TR | EB | W |
| DCB03FN | 2C | RW | TMP_DR0 | 6C | RW | | AC | | | EC | |
| DCB03IN | 2D | RW | TMP_DR1 | 6D | RW | | AD | | | ED | |
| DCB03OU | 2E | RW | TMP_DR2 | 6E | RW | | AE | | | EE | |
| | 2F | | TMP_DR3 | 6F | RW | | AF | | | EF | |
| DBB10FN | 30 | RW | ACB00CR3 | 70 | RW | RDI0RI | B0 | RW | | F0 | |
| DBB10IN | 31 | RW | ACB00CR0 | 71 | RW | RDI0SYN | B1 | RW | | F1 | |
| DBB10OU | 32 | RW | ACB00CR1 | 72 | RW | RDI0IS | B2 | RW | | F2 | |
| | 33 | | ACB00CR2 | 73 | RW | RDI0LT0 | B3 | RW | | F3 | |
| DBB11FN | 34 | RW | ACB01CR3 | 74 | RW | RDI0LT1 | B4 | RW | | F4 | |
| DBB11IN | 35 | RW | ACB01CR0 | 75 | RW | RDI0RO0 | B5 | RW | | F5 | |
| DBB11OU | 36 | RW | ACB01CR1 | 76 | RW | RDI0RO1 | B6 | RW | | F6 | |
| | 37 | | ACB01CR2 | 77 | RW | | B7 | | CPU_F | F7 | RL |
| DCB12FN | 38 | RW | ACB02CR3 | 78 | RW | RDI1RI | B8 | RW | | F8 | |
| DCB12IN | 39 | RW | ACB02CR0 | 79 | RW | RDI1SYN | B9 | RW | | F9 | |
| DCB12OU | 3A | RW | ACB02CR1 | 7A | RW | RDI1IS | BA | RW | FLS_PR1 | FA | RW |
| | 3B | | ACB02CR2 | 7B | RW | RDI1LT0 | BB | RW | | FB | |
| DCB13FN | 3C | RW | ACB03CR3 | 7C | RW | RDI1LT1 | BC | RW | | FC | |
| DCB13IN | 3D | RW | ACB03CR0 | 7D | RW | RDI1RO0 | BD | RW | | FD | |
| DCB13OU | 3E | RW | ACB03CR1 | 7E | RW | RDI1RO1 | BE | RW | CPU_SCR1 | FE | # |
| | 3F | | ACB03CR2 | 7F | RW | | BF | | CPU_SCR0 | FF | # |

Blank fields are Reserved and should not be accessed.

Access is bit specific.

Electrical Specifications

This section presents the DC and AC electrical specifications of the CY8C29x66 PSoC device. For the most up-to-date electrical specifications, confirm that you have the most recent datasheet by going to the web at <http://www.cypress.com>.

Specifications are valid for $-40\text{ }^{\circ}\text{C} \leq T_A \leq 85\text{ }^{\circ}\text{C}$ and $T_J \leq 100\text{ }^{\circ}\text{C}$, except where noted. Refer to Table 29 for the electrical specifications on the internal main oscillator (IMO) using SLIMO mode.

Figure 10. Voltage versus CPU Frequency

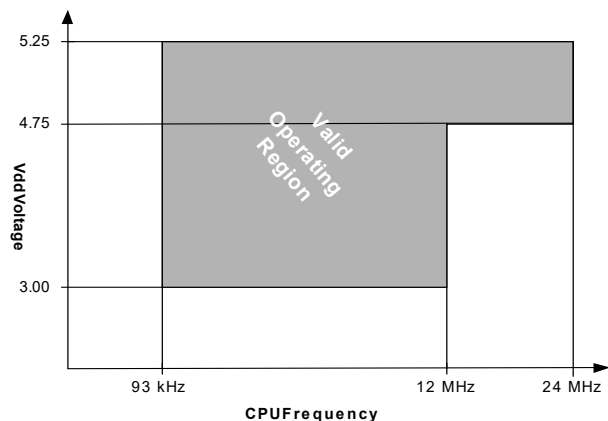
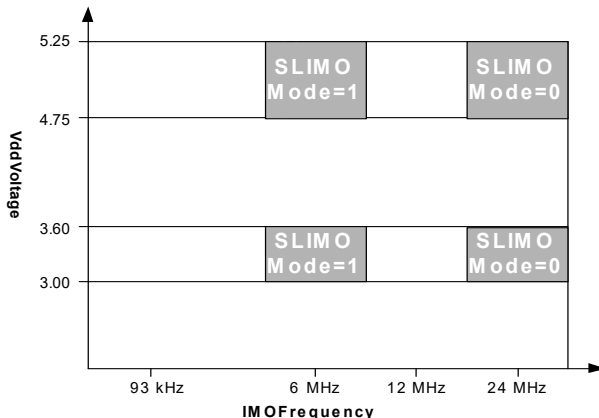

Figure 11. IMO Frequency Options



Absolute Maximum Ratings

Exceeding maximum ratings may shorten the useful life of the device. User guidelines are not tested.

Table 11. Absolute Maximum Ratings

| Symbol | Description | Min | Typ | Max | Unit | Notes |
|----------------|---|-------------------|-----|-------------------|--------------------|--|
| T_{STG} | Storage temperature | -55 | 25 | +100 | $^{\circ}\text{C}$ | Higher storage temperatures reduce data retention time. Recommended storage temperature is $+25\text{ }^{\circ}\text{C} \pm 25\text{ }^{\circ}\text{C}$. Extended duration storage temperatures higher than $65\text{ }^{\circ}\text{C}$ degrade reliability. |
| $T_{BAKETEMP}$ | Bake temperature | - | 125 | See package label | $^{\circ}\text{C}$ | |
| $T_{BAKETIME}$ | Bake time | See package label | - | 72 | Hours | |
| T_A | Ambient temperature with power applied | -40 | - | +85 | $^{\circ}\text{C}$ | |
| V_{DD} | Supply voltage on V_{DD} relative to V_{SS} | -0.5 | - | +6.0 | V | |
| V_{IO} | DC input voltage | $V_{SS} - 0.5$ | - | $V_{DD} + 0.5$ | V | |
| V_{IOZ} | DC voltage applied to tristate | $V_{SS} - 0.5$ | - | $V_{DD} + 0.5$ | V | |
| I_{MIO} | Maximum current into any port pin | -25 | - | +50 | mA | |
| I_{MAIO} | Maximum current into any port pin configured as analog driver | -50 | - | +50 | mA | |
| ESD | Electrostatic discharge voltage | 2000 | - | - | V | Human body model ESD. |
| LU | Latch-up current | - | - | 200 | mA | |

Operating Temperature

Table 12. Operating Temperature

| Symbol | Description | Min | Typ | Max | Unit | Notes |
|--------|----------------------|-----|-----|------|------|---|
| T_A | Ambient temperature | -40 | - | +85 | °C | |
| T_J | Junction temperature | -40 | - | +100 | °C | The temperature rise from ambient to junction is package specific. See “Thermal Impedances” on page 53. You must limit the power consumption to comply with this requirement. |

DC Electrical Characteristics

DC Chip-Level Specifications

Table 13 lists guaranteed maximum and minimum specifications for the voltage and temperature ranges: 4.75 V to 5.25 V and $-40\text{ °C} \leq T_A \leq 85\text{ °C}$, or 3.0 V to 3.6 V and $-40\text{ °C} \leq T_A \leq 85\text{ °C}$, respectively. Typical parameters apply to 5 V and 3.3 V at 25 °C and are for design guidance only.

Table 13. DC Chip-Level Specifications

| Symbol | Description | Min | Typ | Max | Units | Notes |
|-----------------|---|------|-----|------|-------|--|
| $V_{DD}^{[14]}$ | Supply voltage | 3.00 | - | 5.25 | V | See DC POR, SMP, and LVD Specifications on page 38. |
| I_{DD} | Supply current | - | 8 | 14 | mA | Conditions are 5.0 V, $T_A = 25\text{ °C}$, CPU = 3 MHz, SYSCLK doubler disabled, VC1 = 1.5 MHz, VC2 = 93.75 kHz, VC3 = 0.366 kHz. |
| I_{DD3} | Supply current | - | 5 | 9 | mA | Conditions are $V_{DD} = 3.3\text{ V}$, $T_A = 25\text{ °C}$, CPU = 3 MHz, SYSCLK doubler disabled, VC1 = 1.5 MHz, VC2 = 93.75 kHz, VC3 = 0.366 kHz. |
| I_{DDP} | Supply current when IMO = 6 MHz using SLIMO mode. | - | 2 | 3 | mA | Conditions are $V_{DD} = 3.3\text{ V}$, $T_A = 25\text{ °C}$, CPU = 0.75 MHz, SYSCLK doubler disabled, VC1 = 0.375 MHz, VC2 = 23.44 kHz, VC3 = 0.09 kHz. |
| I_{SB} | Sleep (Mode) current with POR, LVD, sleep timer, WDT, and internal slow oscillator active. | - | 3 | 10 | μA | Conditions are with internal slow speed oscillator, $V_{DD} = 3.3\text{ V}$, $-40\text{ °C} \leq T_A \leq 55\text{ °C}$. |
| I_{SBH} | Sleep (Mode) current with POR, LVD, sleep timer, WDT, and internal slow oscillator active. | - | 4 | 25 | μA | Conditions are with internal slow speed oscillator, $V_{DD} = 3.3\text{ V}$, $55\text{ °C} < T_A \leq 85\text{ °C}$. |
| I_{SBXTL} | Sleep (Mode) current with POR, LVD, sleep timer, WDT, internal slow oscillator, and 32 kHz crystal oscillator active. | - | 4 | 12 | μA | Conditions are with properly loaded, 1 μW max, 32.768 kHz crystal. $V_{DD} = 3.3\text{ V}$, $-40\text{ °C} \leq T_A \leq 55\text{ °C}$. |
| I_{SBXTLH} | Sleep (Mode) current with POR, LVD, sleep timer, WDT, and 32 kHz crystal oscillator active. | - | 5 | 27 | μA | Conditions are with properly loaded, 1 μW max, 32.768 kHz crystal. $V_{DD} = 3.3\text{ V}$, $55\text{ °C} < T_A \leq 85\text{ °C}$. |
| V_{REF} | Reference voltage (Bandgap) | 1.28 | 1.3 | 1.32 | V | Trimmed for appropriate V_{DD} . |

Note

14. Errata: When V_{DD} of the device is pulled below ground just before power-on; the first read from each 8K Flash bank may be corrupted apart from flash bank 0. This can be solved by doing a dummy read from each flash bank prior to use of the Flash banks. For more information, see [Errata on page 63](#).

DC GPIO Specifications

Table 14 lists guaranteed maximum and minimum specifications for the voltage and temperature ranges: 4.75 V to 5.25 V and $-40\text{ }^{\circ}\text{C} \leq T_A \leq 85\text{ }^{\circ}\text{C}$, or 3.0 V to 3.6 V and $-40\text{ }^{\circ}\text{C} \leq T_A \leq 85\text{ }^{\circ}\text{C}$, respectively. Typical parameters apply to 5 V and 3.3 V at 25 °C and are for design guidance only.

Table 14. DC GPIO Specifications

| Symbol | Description | Min | Typ | Max | Unit | Notes |
|------------------|-----------------------------------|-----------------------|-----|------|------|---|
| R _{PU} | Pull-up resistor | 4 | 5.6 | 8 | kΩ | |
| R _{PD} | Pull-down resistor | 4 | 5.6 | 8 | kΩ | |
| V _{OH} | High output level | V _{DD} - 1.0 | – | – | V | I _{OH} = 10 mA, V _{DD} = 4.75 to 5.25 V (8 total loads, 4 on even port pins (for example, P0[2], P1[4]), 4 on odd port pins (for example, P0[3], P1[5])). 80 mA maximum combined I _{OH} budget. |
| V _{OL} | Low output level | – | – | 0.75 | V | I _{OL} = 25 mA, V _{DD} = 4.75 to 5.25 V (8 total loads, 4 on even port pins (for example, P0[2], P1[4]), 4 on odd port pins (for example, P0[3], P1[5])). 150 mA maximum combined I _{OL} budget. |
| I _{OH} | High level source current | 10 | – | – | mA | V _{OH} = V _{DD} - 1.0 V, see the limitations of the total current in the note for V _{OH} |
| I _{OL} | Low level sink current | 25 | – | – | mA | V _{OL} = 0.75 V, see the limitations of the total current in the note for V _{OL} |
| V _{IL} | Input low level | – | – | 0.8 | V | V _{DD} = 3.0 to 5.25 |
| V _{IH} | Input high level | 2.1 | – | – | V | V _{DD} = 3.0 to 5.25 |
| V _H | Input hysteresis | – | 60 | – | mV | |
| I _{IL} | Input leakage (absolute value) | – | 1 | – | nA | Gross tested to 1 μA. |
| C _{IN} | Capacitive load on pins as input | – | 3.5 | 10 | pF | Package and pin dependent. Temp = 25 °C. |
| C _{OUT} | Capacitive load on pins as output | – | 3.5 | 10 | pF | Package and pin dependent. Temp = 25 °C. |

DC Operational Amplifier Specifications

Table 15 and Table 16 list guaranteed maximum and minimum specifications for the voltage and temperature ranges: 4.75 V to 5.25 V and $-40\text{ }^{\circ}\text{C} \leq T_A \leq 85\text{ }^{\circ}\text{C}$, or 3.0 V to 3.6 V and $-40\text{ }^{\circ}\text{C} \leq T_A \leq 85\text{ }^{\circ}\text{C}$, respectively. Typical parameters apply to 5 V and 3.3 V at 25 °C and are for design guidance only.

The Operational Amplifier is a component of both the Analog Continuous Time PSoC blocks and the Analog Switched Cap PSoC blocks. The guaranteed specifications are measured in the Analog Continuous Time PSoC block. Typical parameters apply to 5 V at 25 °C and are for design guidance only.

Table 15. 5-V DC Operational Amplifier Specifications

| Symbol | Description | Min | Typ | Max | Unit | Notes |
|---------------------|---|------------------------|------|-----------------------|-------|--|
| V _{OSOA} | Input offset voltage (absolute value) | | | | | |
| | Power = Low, Opamp bias = Low | – | 1.6 | 10 | mV | |
| | Power = Low, Opamp bias = High | – | 1.6 | 10 | mV | |
| | Power = Medium, Opamp bias = Low | – | 1.6 | 10 | mV | |
| | Power = Medium, Opamp bias = High | – | 1.6 | 10 | mV | |
| | Power = High, Opamp bias = Low | – | 1.6 | 10 | mV | |
| | Power = High, Opamp bias = High | – | 1.6 | 10 | mV | |
| TCV _{OSOA} | Average input offset voltage drift | – | 4 | 23 | μV/°C | |
| I _{EBOA} | Input leakage current (port 0 analog pins) | – | 200 | – | pA | Gross tested to 1 μA |
| C _{INOA} | Input capacitance (port 0 analog pins) | – | 4.5 | 9.5 | pF | Package and pin dependent. Temp = 25 °C |
| V _{CMOA} | Common mode voltage range (All cases, except Power = High, Opamp bias = High) | 0 | – | V _{DD} | V | The common-mode input voltage range is measured through an analog output buffer. |
| | Common mode voltage range (Power = High, Opamp bias = High) | 0.5 | – | V _{DD} – 0.5 | V | The specification includes the limitations imposed by the characteristics of the analog output buffer. |
| CMR-ROA | Common mode rejection ratio | 60 | – | – | dB | |
| GOLOA | Open loop gain | 80 | – | – | dB | |
| VOHIG-HOA | High output voltage swing (internal signals) | V _{DD} – 0.01 | – | – | V | |
| VOLOWOA | Low output voltage swing (internal signals) | – | – | 0.1 | V | |
| ISOA | Supply current (including associated AGND buffer) | | | | | |
| | Power = Low, Opamp bias = Low | – | 150 | 200 | μA | |
| | Power = Low, Opamp bias = High | – | 300 | 400 | μA | |
| | Power = Medium, Opamp bias = Low | – | 600 | 800 | μA | |
| | Power = Medium, Opamp bias = High | – | 1200 | 1600 | μA | |
| | Power = High, Opamp bias = Low | – | 2400 | 3200 | μA | |
| | Power = High, Opamp bias = High | – | 4600 | 6400 | μA | |
| PSR-ROA | Supply voltage rejection ratio | 67 | 80 | – | dB | V _{SS} ≤ V _{IN} ≤ (V _{DD} – 2.25) or (V _{DD} – 1.25 V) ≤ V _{IN} ≤ V _{DD} . |

Table 16. 3.3-V DC Operational Amplifier Specifications

| Symbol | Description | Min | Typ | Max | Unit | Notes |
|---------------------------------|---|------------------------|------|-----------------|-------|--|
| V _{OSOA} | Input offset voltage (absolute value) | – | 1.4 | 10 | mV | Power = High, Opamp bias = High setting is not allowed for 3.3 V V _{DD} operation. |
| | Power = Low, Opamp bias = Low | – | 1.4 | 10 | mV | |
| | Power = Low, Opamp bias = High | – | 1.4 | 10 | mV | |
| | Power = Medium, Opamp bias = Low | – | 1.4 | 10 | mV | |
| | Power = Medium, Opamp bias = High | – | 1.4 | 10 | mV | |
| | Power = High, Opamp bias = Low | – | 1.4 | 10 | mV | |
| Power = High, Opamp bias = High | – | – | – | – | mV | |
| TCV _{OSOA} | Average input offset voltage drift | – | 7 | 40 | μV/°C | |
| I _{EBOA} | Input leakage current (port 0 analog pins) | – | 200 | – | pA | Gross tested to 1 μA. |
| C _{INOA} | Input capacitance (port 0 analog pins) | – | 4.5 | 9.5 | pF | Package and pin dependent. Temp = 25 °C |
| V _{CMOA} | Common mode voltage range | 0 | – | V _{DD} | V | The common-mode input voltage range is measured through an analog output buffer. The specification includes the limitations imposed by the characteristics of the analog output buffer. |
| CMRR _{OA} | Common mode rejection ratio | 60 | – | – | dB | |
| G _{OLOA} | Open loop gain | 80 | – | – | dB | |
| V _{OHIGHOA} | High output voltage swing (internal signals) | V _{DD} – 0.01 | – | – | V | |
| V _{OLOWOA} | Low output voltage swing (internal signals) | – | – | 0.01 | V | |
| I _{SOA} | Supply current (including associated AGND buffer) | – | – | – | – | Power = High, Opamp bias = High setting is not allowed for 3.3 V V _{DD} operation. |
| | Power = Low, Opamp bias = Low | – | 150 | 200 | μA | |
| | Power = Low, Opamp bias = High | – | 300 | 400 | μA | |
| | Power = Medium, Opamp bias = Low | – | 600 | 800 | μA | |
| | Power = Medium, Opamp bias = High | – | 1200 | 1600 | μA | |
| | Power = High, Opamp bias = Low | – | 2400 | 3200 | μA | |
| Power = High, Opamp bias = High | – | – | – | – | μA | |
| PSRR _{OA} | Supply voltage rejection ratio | 54 | 80 | – | dB | V _{SS} ≤ V _{IN} ≤ (V _{DD} – 2.25) or (V _{DD} – 1.25 V) ≤ V _{IN} ≤ V _{DD} |

DC Low-Power Comparator Specifications

Table 17 lists guaranteed maximum and minimum specifications for the voltage and temperature ranges: 4.75 V to 5.25 V and –40 °C ≤ T_A ≤ 85 °C, 3.0 V to 3.6 V and –40 °C ≤ T_A ≤ 85 °C, or 2.4 V to 3.0 V and –40 °C ≤ T_A ≤ 85 °C, respectively. Typical parameters apply to 5 V at 25 °C and are for design guidance only.

Table 17. DC Low-Power Comparator Specifications

| Symbol | Description | Min | Typ | Max | Unit |
|---------------------|--|-----|-----|---------------------|------|
| V _{REFLPC} | Low-power comparator (LPC) reference voltage range | 0.2 | – | V _{DD} – 1 | V |
| I _{SLPC} | LPC supply current | – | 10 | 40 | μA |
| V _{OSSLPC} | LPC voltage offset | – | 2.5 | 30 | mV |

DC Analog Output Buffer Specifications

Table 18 and Table 19 list guaranteed maximum and minimum specifications for the voltage and temperature ranges: 4.75 V to 5.25 V and $-40\text{ }^{\circ}\text{C} \leq T_A \leq 85\text{ }^{\circ}\text{C}$, or 3.0 V to 3.6 V and $-40\text{ }^{\circ}\text{C} \leq T_A \leq 85\text{ }^{\circ}\text{C}$, respectively. Typical parameters apply to 5 V and 3.3 V at 25 °C and are for design guidance only.

Table 18. 5-V DC Analog Output Buffer Specifications

| Symbol | Description | Min | Typ | Max | Unit | Notes |
|---------------|--|---------------------------|-----|---------------------------|--------------------------------|--|
| V_{OSOB} | Input offset voltage (absolute value) | | | | | |
| | Power = Low, Opamp bias = Low | – | 3.2 | 18 | mV | |
| | Power = Low, Opamp bias = High | – | 3.2 | 18 | mV | |
| | Power = High, Opamp bias = Low | – | 3.2 | 18 | mV | |
| | Power = High, Opamp bias = High | – | 3.2 | 18 | mV | |
| TCV_{OSOB} | Average input offset voltage drift | – | 5.5 | 26 | $\mu\text{V}/^{\circ}\text{C}$ | |
| V_{CMOB} | Common-mode input voltage range | 0.5 | – | $V_{DD} - 1.0$ | V | |
| R_{OUTOB} | Output resistance | | | | | |
| | Power = Low | – | – | 1 | Ω | |
| | Power = High | – | – | 1 | Ω | |
| $V_{OHIGHOB}$ | High output voltage swing (Load = 32 ohms to $V_{DD}/2$) | | | | | |
| | Power = Low | $0.5 \times V_{DD} + 1.3$ | – | – | V | |
| | Power = High | $0.5 \times V_{DD} + 1.3$ | – | – | V | |
| V_{OLOWOB} | Low output voltage swing (Load = 32 ohms to $V_{DD}/2$) | | | | | |
| | Power = Low | – | – | $0.5 \times V_{DD} - 1.3$ | V | |
| | Power = High | – | – | $0.5 \times V_{DD} - 1.3$ | V | |
| I_{SOB} | Supply current including bias cell (no load) | | | | | |
| | Power = Low | – | 1.1 | 2 | mA | |
| | Power = High | – | 2.6 | 5 | mA | |
| $PSRR_{OB}$ | Supply voltage rejection ratio | 40 | 64 | | dB | |
| C_L | Load capacitance | – | – | 200 | pF | This specification applies to the external circuit driven by the analog output buffer. |

Table 19. 3.3-V DC Analog Output Buffer Specifications

| Symbol | Description | Min | Typ | Max | Unit | Notes |
|----------------------|---|--------------|-----------------------------|-----------------------------|-------|--|
| V _{OSOB} | Input offset voltage (absolute value) | | | | | High power setting is not recommended. |
| | Power = Low, Opamp bias = Low | – | 3.2 | 20 | mV | |
| | Power = Low, Opamp bias = High | – | 3.2 | 20 | mV | |
| | Power = High, Opamp bias = Low | – | 6 | 25 | mV | |
| TCV _{OSOB} | Average input offset voltage drift | | | | | High power setting is not recommended. |
| | Power = Low, Opamp bias = Low | – | 8 | 32 | μV/°C | |
| | Power = Low, Opamp bias = High | – | 8 | 32 | μV/°C | |
| | Power = High, Opamp bias = Low | – | 12 | 41 | μV/°C | |
| V _{CMOB} | Common-mode input voltage range | 0.5 | – | V _{DD} – 1.0 | V | |
| | | | | | | |
| R _{OUTOB} | Output resistance | Power = Low | – | 10 | Ω | |
| | | Power = High | – | 10 | Ω | |
| V _{OHIGHOB} | High output voltage swing (Load = 32 ohms to V _{DD} /2) | Power = Low | 0.5 × V _{DD} + 1.0 | – | V | |
| | | Power = High | 0.5 × V _{DD} + 1.0 | – | V | |
| V _{LOWOB} | Low output voltage swing (Load = 32 ohms to V _{DD} /2) | Power = Low | – | 0.5 × V _{DD} – 1.0 | V | |
| | | Power = High | – | 0.5 × V _{DD} – 1.0 | V | |
| I _{SOB} | Supply current including bias cell (no load) | Power = Low | – | 0.8 | mA | |
| | | Power = High | – | 2.0 | 5 | mA |
| PSRR _{OB} | Supply voltage rejection ratio | 60 | 64 | – | dB | |
| C _L | Load capacitance | – | – | 200 | pF | This specification applies to the external circuit driven by the analog output buffer. |

DC Switch Mode Pump Specifications

Table 20 lists guaranteed maximum and minimum specifications for the voltage and temperature ranges: 4.75 V to 5.25 V and $-40\text{ }^{\circ}\text{C} \leq T_A \leq 85\text{ }^{\circ}\text{C}$, or 3.0 V to 3.6 V and $-40\text{ }^{\circ}\text{C} \leq T_A \leq 85\text{ }^{\circ}\text{C}$, respectively. Typical parameters apply to 5 V and 3.3 V at 25 °C and are for design guidance only.

Table 20. DC Switch Mode Pump (SMP) Specifications

| Symbol | Description | Min | Typ | Max | Unit | Notes |
|----------------------------------|---|--------|--------|--------|------------------|--|
| $V_{\text{PUMP } 5\text{ V}}$ | 5 V output voltage at V_{DD} from pump | 4.75 | 5.0 | 5.25 | V | Configured as in Note 15. Average, neglecting ripple. SMP trip voltage is set to 5.0 V |
| $V_{\text{PUMP } 3\text{ V}}$ | 3 V output voltage at V_{DD} from pump | 3.00 | 3.25 | 3.60 | V | Configured as in Note 15. Average, neglecting ripple. SMP trip voltage is set to 3.25 V |
| I_{PUMP} | Available output current $V_{\text{BAT}} = 1.5\text{ V}$, $V_{\text{PUMP}} = 3.25\text{ V}$ $V_{\text{BAT}} = 1.8\text{ V}$, $V_{\text{PUMP}} = 5.0\text{ V}$ | 8 5 | – – | – – | mA mA | Configured as in Note 15 SMP trip voltage is set to 3.25 V SMP trip voltage is set to 5.0 V |
| $V_{\text{BAT}5\text{ V}}$ | Input voltage range from battery | 1.8 | – | 5.0 | V | Configured as in Note 15. SMP trip voltage is set to 5.0 V |
| $V_{\text{BAT}3\text{ V}}$ | Input voltage range from battery | 1.0 | – | 3.3 | V | Configured as in Note 15. SMP trip voltage is set to 3.25 V |
| V_{BATSTART} | Minimum input voltage from battery to start pump | 1.2 | – | – | V | Configured as in Note 15. $15.0\text{ }^{\circ}\text{C} \leq T_A \leq 100$. 1.25 V at $T_A = -40\text{ }^{\circ}\text{C}$ |
| $\Delta V_{\text{PUMP_Line}}$ | Line regulation (over V_{BAT} range) | – | 5 | – | % V_{O} | Configured as in Note 15. V_{O} is the “ V_{DD} Value for PUMP Trip” specified by the VM[2:0] setting in the DC POR and LVD Specification, Table 26, “DC POR, SMP, and LVD Specifications,” on page 38 |
| $\Delta V_{\text{PUMP_Load}}$ | Load regulation | – | 5 | – | % V_{O} | Configured as in Note 15. V_{O} is the “ V_{DD} Value for PUMP Trip” specified by the VM[2:0] setting in Table 26, “DC POR, SMP, and LVD Specifications,” on page 38 |
| $\Delta V_{\text{PUMP_Ripple}}$ | Output voltage ripple (depends on capacitor/load) | – | 100 | – | mVpp | Configured as in Note 15. Load is 5 mA |
| E_3 | Efficiency | 35 | 50 | – | % | Configured as in Note 15. Load is 5 mA. SMP trip voltage is set to 3.25 V |
| F_{PUMP} | Switching frequency | – | 1.4 | – | MHz | |
| DC_{PUMP} | Switching duty cycle | – | 50 | – | % | |

Note

15. $L_1 = 2\text{ }\mu\text{H}$ inductor, $C_1 = 10\text{ }\mu\text{F}$ capacitor, $D_1 =$ Schottky diode. See Figure 12.

Figure 12. Basic Switch Mode Pump Circuit

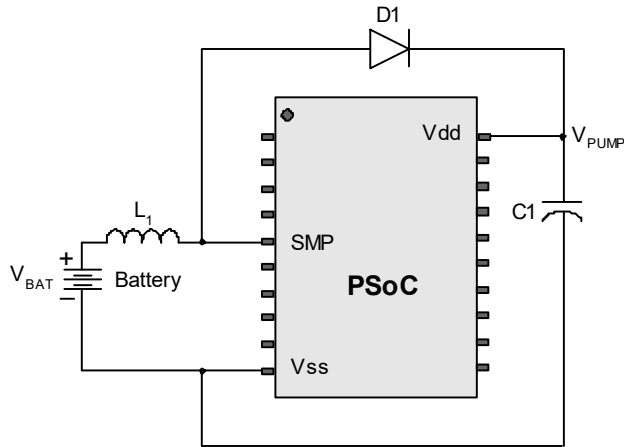

DC Analog Reference Specifications

The following tables list guaranteed maximum and minimum specifications for the voltage and temperature ranges: 4.75 V to 5.25 V and $-40\text{ }^{\circ}\text{C} \leq T_A \leq 85\text{ }^{\circ}\text{C}$, or 3.0 V to 3.6 V and $-40\text{ }^{\circ}\text{C} \leq T_A \leq 85\text{ }^{\circ}\text{C}$, respectively. Typical parameters apply to 5 V and 3.3 V at 25 $^{\circ}\text{C}$ and are for design guidance only.

The guaranteed specifications for RefHI and RefLO are measured through the analog continuous time PSoC blocks. The power levels for RefHI and RefLO refer to the analog reference control register. AGND is measured at P2[4] in AGND bypass mode. Each analog continuous time PSoC block adds a maximum of 10 mV additional offset error to guaranteed AGND specifications from the local AGND buffer. Reference control power can be set to medium or high unless otherwise noted.

Note Avoid using P2[4] for digital signaling when using an analog resource that depends on the analog reference. Some coupling of the digital signal may appear on the AGND.

Table 21. 5-V DC Analog Reference Specifications

| Reference ARF_CR[5:3] | Reference Power Settings | Symbol | Reference | Description | Min | Typ | Max | Unit |
|-----------------------|--------------------------------------|--------------------|-----------|------------------------------|----------------------------|----------------------------|----------------------------|------|
| 0b000 | RefPower = High Opamp bias = High | V _{REFHI} | Ref High | V _{DD} /2 + Bandgap | V _{DD} /2 + 1.228 | V _{DD} /2 + 1.290 | V _{DD} /2 + 1.352 | V |
| | | V _{AGND} | AGND | V _{DD} /2 | V _{DD} /2 - 0.078 | V _{DD} /2 - 0.007 | V _{DD} /2 + 0.063 | V |
| | | V _{REFLO} | Ref Low | V _{DD} /2 - Bandgap | V _{DD} /2 - 1.336 | V _{DD} /2 - 1.295 | V _{DD} /2 - 1.250 | V |
| | RefPower = High Opamp bias = Low | V _{REFHI} | Ref High | V _{DD} /2 + Bandgap | V _{DD} /2 + 1.224 | V _{DD} /2 + 1.293 | V _{DD} /2 + 1.356 | V |
| | | V _{AGND} | AGND | V _{DD} /2 | V _{DD} /2 - 0.056 | V _{DD} /2 - 0.005 | V _{DD} /2 + 0.043 | V |
| | | V _{REFLO} | Ref Low | V _{DD} /2 - Bandgap | V _{DD} /2 - 1.338 | V _{DD} /2 - 1.298 | V _{DD} /2 - 1.255 | V |
| | RefPower = Med Opamp bias = High | V _{REFHI} | Ref High | V _{DD} /2 + Bandgap | V _{DD} /2 + 1.226 | V _{DD} /2 + 1.293 | V _{DD} /2 + 1.356 | V |
| | | V _{AGND} | AGND | V _{DD} /2 | V _{DD} /2 - 0.057 | V _{DD} /2 - 0.006 | V _{DD} /2 + 0.044 | V |
| | | V _{REFLO} | Ref Low | V _{DD} /2 - Bandgap | V _{DD} /2 - 1.337 | V _{DD} /2 - 1.298 | V _{DD} /2 - 1.256 | V |
| | RefPower = Med Opamp bias = Low | V _{REFHI} | Ref High | V _{DD} /2 + Bandgap | V _{DD} /2 + 1.226 | V _{DD} /2 + 1.294 | V _{DD} /2 + 1.359 | V |
| | | V _{AGND} | AGND | V _{DD} /2 | V _{DD} /2 - 0.047 | V _{DD} /2 - 0.004 | V _{DD} /2 + 0.035 | V |
| | | V _{REFLO} | Ref Low | V _{DD} /2 - Bandgap | V _{DD} /2 - 1.338 | V _{DD} /2 - 1.299 | V _{DD} /2 - 1.258 | V |

Table 21. 5-V DC Analog Reference Specifications (continued)

| Reference ARF_CR[5:3] | Reference Power Settings | Symbol | Reference | Description | Min | Typ | Max | Unit |
|-----------------------|--------------------------------------|--------------------|-----------|---|----------------------------|----------------------------|----------------------------|------|
| 0b001 | RefPower = High Opamp bias = High | V _{REFHI} | Ref High | P2[4] + P2[6] (P2[4] = V _{DD} /2, P2[6] = 1.3 V) | P2[4] + P2[6] – 0.085 | P2[4] + P2[6] – 0.016 | P2[4] + P2[6] + 0.044 | V |
| | | V _{AGND} | AGND | P2[4] | P2[4] | P2[4] | P2[4] | – |
| | | V _{REFLO} | Ref Low | P2[4] – P2[6] (P2[4] = V _{DD} /2, P2[6] = 1.3 V) | P2[4] – P2[6] – 0.022 | P2[4] – P2[6] + 0.010 | P2[4] – P2[6] + 0.055 | V |
| | RefPower = High Opamp bias = Low | V _{REFHI} | Ref High | P2[4] + P2[6] (P2[4] = V _{DD} /2, P2[6] = 1.3 V) | P2[4] + P2[6] – 0.077 | P2[4] + P2[6] – 0.010 | P2[4] + P2[6] + 0.051 | V |
| | | V _{AGND} | AGND | P2[4] | P2[4] | P2[4] | P2[4] | – |
| | | V _{REFLO} | Ref Low | P2[4] – P2[6] (P2[4] = V _{DD} /2, P2[6] = 1.3 V) | P2[4] – P2[6] – 0.022 | P2[4] – P2[6] + 0.005 | P2[4] – P2[6] + 0.039 | V |
| | RefPower = Med Opamp bias = High | V _{REFHI} | Ref High | P2[4] + P2[6] (P2[4] = V _{DD} /2, P2[6] = 1.3 V) | P2[4] + P2[6] – 0.070 | P2[4] + P2[6] – 0.010 | P2[4] + P2[6] + 0.050 | V |
| | | V _{AGND} | AGND | P2[4] | P2[4] | P2[4] | P2[4] | – |
| | | V _{REFLO} | Ref Low | P2[4] – P2[6] (P2[4] = V _{DD} /2, P2[6] = 1.3 V) | P2[4] – P2[6] – 0.022 | P2[4] – P2[6] + 0.005 | P2[4] – P2[6] + 0.039 | V |
| | RefPower = Med Opamp bias = Low | V _{REFHI} | Ref High | P2[4] + P2[6] (P2[4] = V _{DD} /2, P2[6] = 1.3 V) | P2[4] + P2[6] – 0.070 | P2[4] + P2[6] – 0.007 | P2[4] + P2[6] + 0.054 | V |
| | | V _{AGND} | AGND | P2[4] | P2[4] | P2[4] | P2[4] | – |
| | | V _{REFLO} | Ref Low | P2[4] – P2[6] (P2[4] = V _{DD} /2, P2[6] = 1.3 V) | P2[4] – P2[6] – 0.022 | P2[4] – P2[6] + 0.002 | P2[4] – P2[6] + 0.032 | V |
| 0b010 | RefPower = High Opamp bias = High | V _{REFHI} | Ref High | V _{DD} | V _{DD} – 0.037 | V _{DD} – 0.009 | V _{DD} | V |
| | | V _{AGND} | AGND | V _{DD} /2 | V _{DD} /2 – 0.061 | V _{DD} /2 – 0.006 | V _{DD} /2 + 0.047 | V |
| | | V _{REFLO} | Ref Low | V _{SS} | V _{SS} | V _{SS} + 0.007 | V _{SS} + 0.028 | V |
| | RefPower = High Opamp bias = Low | V _{REFHI} | Ref High | V _{DD} | V _{DD} – 0.039 | V _{DD} – 0.006 | V _{DD} | V |
| | | V _{AGND} | AGND | V _{DD} /2 | V _{DD} /2 – 0.049 | V _{DD} /2 – 0.005 | V _{DD} /2 + 0.036 | V |
| | | V _{REFLO} | Ref Low | V _{SS} | V _{SS} | V _{SS} + 0.005 | V _{SS} + 0.019 | V |
| | RefPower = Med Opamp bias = High | V _{REFHI} | Ref High | V _{DD} | V _{DD} – 0.037 | V _{DD} – 0.007 | V _{DD} | V |
| | | V _{AGND} | AGND | V _{DD} /2 | V _{DD} /2 – 0.054 | V _{DD} /2 – 0.005 | V _{DD} /2 + 0.041 | V |
| | | V _{REFLO} | Ref Low | V _{SS} | V _{SS} | V _{SS} + 0.006 | V _{SS} + 0.024 | V |
| | RefPower = Med Opamp bias = Low | V _{REFHI} | Ref High | V _{DD} | V _{DD} – 0.042 | V _{DD} – 0.005 | V _{DD} | V |
| | | V _{AGND} | AGND | V _{DD} /2 | V _{DD} /2 – 0.046 | V _{DD} /2 – 0.004 | V _{DD} /2 + 0.034 | V |
| | | V _{REFLO} | Ref Low | V _{SS} | V _{SS} | V _{SS} + 0.004 | V _{SS} + 0.017 | V |

Table 21. 5-V DC Analog Reference Specifications (continued)

| Reference ARF_CR[5:3] | Reference Power Settings | Symbol | Reference | Description | Min | Typ | Max | Unit |
|-----------------------|--------------------------------------|--------------------|-----------|-------------------------------------|---------------|---------------|---------------|------|
| 0b011 | RefPower = High Opamp bias = High | V _{REFHI} | Ref High | 3 × Bandgap | 3.788 | 3.891 | 3.986 | V |
| | | V _{AGND} | AGND | 2 × Bandgap | 2.500 | 2.604 | 2.699 | V |
| | | V _{REFLO} | Ref Low | Bandgap | 1.257 | 1.306 | 1.359 | V |
| | RefPower = High Opamp bias = Low | V _{REFHI} | Ref High | 3 × Bandgap | 3.792 | 3.893 | 3.982 | V |
| | | V _{AGND} | AGND | 2 × Bandgap | 2.518 | 2.602 | 2.692 | V |
| | | V _{REFLO} | Ref Low | Bandgap | 1.256 | 1.302 | 1.354 | V |
| | RefPower = Med Opamp bias = High | V _{REFHI} | Ref High | 3 × Bandgap | 3.795 | 3.894 | 3.993 | V |
| | | V _{AGND} | AGND | 2 × Bandgap | 2.516 | 2.603 | 2.698 | V |
| | | V _{REFLO} | Ref Low | Bandgap | 1.256 | 1.303 | 1.353 | V |
| | RefPower = Med Opamp bias = Low | V _{REFHI} | Ref High | 3 × Bandgap | 3.792 | 3.895 | 3.986 | V |
| | | V _{AGND} | AGND | 2 × Bandgap | 2.522 | 2.602 | 2.685 | V |
| | | V _{REFLO} | Ref Low | Bandgap | 1.255 | 1.301 | 1.350 | V |
| 0b100 | RefPower = High Opamp bias = High | V _{REFHI} | Ref High | 2 × Bandgap + P2[6] (P2[6] = 1.3 V) | 2.495 + P2[6] | 2.586 + P2[6] | 2.657 + P2[6] | V |
| | | V _{AGND} | AGND | 2 × Bandgap | 2.502 | 2.604 | 2.719 | V |
| | | V _{REFLO} | Ref Low | 2 × Bandgap – P2[6] (P2[6] = 1.3 V) | 2.531 – P2[6] | 2.611 – P2[6] | 2.681 – P2[6] | V |
| | RefPower = High Opamp bias = Low | V _{REFHI} | Ref High | 2 × Bandgap + P2[6] (P2[6] = 1.3 V) | 2.500 + P2[6] | 2.591 + P2[6] | 2.662 + P2[6] | V |
| | | V _{AGND} | AGND | 2 × Bandgap | 2.519 | 2.602 | 2.693 | V |
| | | V _{REFLO} | Ref Low | 2 × Bandgap – P2[6] (P2[6] = 1.3 V) | 2.530 – P2[6] | 2.605 – P2[6] | 2.666 – P2[6] | V |
| | RefPower = Med Opamp bias = High | V _{REFHI} | Ref High | 2 × Bandgap + P2[6] (P2[6] = 1.3 V) | 2.503 + P2[6] | 2.592 + P2[6] | 2.662 + P2[6] | V |
| | | V _{AGND} | AGND | 2 × Bandgap | 2.517 | 2.603 | 2.698 | V |
| | | V _{REFLO} | Ref Low | 2 × Bandgap – P2[6] (P2[6] = 1.3 V) | 2.529 – P2[6] | 2.606 – P2[6] | 2.665 – P2[6] | V |
| | RefPower = Med Opamp bias = Low | V _{REFHI} | Ref High | 2 × Bandgap + P2[6] (P2[6] = 1.3 V) | 2.505 + P2[6] | 2.594 + P2[6] | 2.665 + P2[6] | V |
| | | V _{AGND} | AGND | 2 × Bandgap | 2.525 | 2.602 | 2.685 | V |
| | | V _{REFLO} | Ref Low | 2 × Bandgap – P2[6] (P2[6] = 1.3 V) | 2.528 – P2[6] | 2.603 – P2[6] | 2.661 – P2[6] | V |

Table 21. 5-V DC Analog Reference Specifications (continued)

| Reference ARF_CR[5:3] | Reference Power Settings | Symbol | Reference | Description | Min | Typ | Max | Unit |
|-----------------------|--------------------------------------|--------------------|-----------|---|-----------------|-------------------------|-------------------------|------|
| 0b101 | RefPower = High Opamp bias = High | V _{REFHI} | Ref High | P2[4] + Bandgap (P2[4] = V _{DD} /2) | P2[4] + 1.222 | P2[4] + 1.290 | P2[4] + 1.343 | V |
| | | V _{AGND} | AGND | P2[4] | P2[4] | P2[4] | P2[4] | – |
| | | V _{REFLO} | Ref Low | P2[4] – Bandgap (P2[4] = V _{DD} /2) | P2[4] – 1.331 | P2[4] – 1.295 | P2[4] – 1.254 | V |
| | RefPower = High Opamp bias = Low | V _{REFHI} | Ref High | P2[4] + Bandgap (P2[4] = V _{DD} /2) | P2[4] + 1.226 | P2[4] + 1.293 | P2[4] + 1.347 | V |
| | | V _{AGND} | AGND | P2[4] | P2[4] | P2[4] | P2[4] | – |
| | | V _{REFLO} | Ref Low | P2[4] – Bandgap (P2[4] = V _{DD} /2) | P2[4] – 1.331 | P2[4] – 1.298 | P2[4] – 1.259 | V |
| | RefPower = Med Opamp bias = High | V _{REFHI} | Ref High | P2[4] + Bandgap (P2[4] = V _{DD} /2) | P2[4] + 1.227 | P2[4] + 1.294 | P2[4] + 1.347 | V |
| | | V _{AGND} | AGND | P2[4] | P2[4] | P2[4] | P2[4] | – |
| | | V _{REFLO} | Ref Low | P2[4] – Bandgap (P2[4] = V _{DD} /2) | P2[4] – 1.331 | P2[4] – 1.298 | P2[4] – 1.259 | V |
| | RefPower = Med Opamp bias = Low | V _{REFHI} | Ref High | P2[4] + Bandgap (P2[4] = V _{DD} /2) | P2[4] + 1.228 | P2[4] + 1.295 | P2[4] + 1.349 | V |
| | | V _{AGND} | AGND | P2[4] | P2[4] | P2[4] | P2[4] | – |
| | | V _{REFLO} | Ref Low | P2[4] – Bandgap (P2[4] = V _{DD} /2) | P2[4] – 1.332 | P2[4] – 1.299 | P2[4] – 1.260 | V |
| 0b110 | RefPower = High Opamp bias = High | V _{REFHI} | Ref High | 2 × Bandgap | 2.535 | 2.598 | 2.644 | V |
| | | V _{AGND} | AGND | Bandgap | 1.227 | 1.305 | 1.398 | V |
| | | V _{REFLO} | Ref Low | V _{SS} | V _{SS} | V _{SS} + 0.009 | V _{SS} + 0.038 | V |
| | RefPower = High Opamp bias = Low | V _{REFHI} | Ref High | 2 × Bandgap | 2.530 | 2.598 | 2.643 | V |
| | | V _{AGND} | AGND | Bandgap | 1.244 | 1.303 | 1.370 | V |
| | | V _{REFLO} | Ref Low | V _{SS} | V _{SS} | V _{SS} + 0.005 | V _{SS} + 0.024 | V |
| | RefPower = Med Opamp bias = High | V _{REFHI} | Ref High | 2 × Bandgap | 2.532 | 2.598 | 2.644 | V |
| | | V _{AGND} | AGND | Bandgap | 1.239 | 1.304 | 1.380 | V |
| | | V _{REFLO} | Ref Low | V _{SS} | V _{SS} | V _{SS} + 0.006 | V _{SS} + 0.026 | V |
| | RefPower = Med Opamp bias = Low | V _{REFHI} | Ref High | 2 × Bandgap | 2.528 | 2.598 | 2.645 | V |
| | | V _{AGND} | AGND | Bandgap | 1.249 | 1.302 | 1.362 | V |
| | | V _{REFLO} | Ref Low | V _{SS} | V _{SS} | V _{SS} + 0.004 | V _{SS} + 0.018 | V |
| 0b111 | RefPower = High Opamp bias = High | V _{REFHI} | Ref High | 3.2 × Bandgap | 4.041 | 4.155 | 4.234 | V |
| | | V _{AGND} | AGND | 1.6 × Bandgap | 1.998 | 2.083 | 2.183 | V |
| | | V _{REFLO} | Ref Low | V _{SS} | V _{SS} | V _{SS} + 0.010 | V _{SS} + 0.038 | V |
| | RefPower = High Opamp bias = Low | V _{REFHI} | Ref High | 3.2 × Bandgap | 4.047 | 4.153 | 4.236 | V |
| | | V _{AGND} | AGND | 1.6 × Bandgap | 2.012 | 2.082 | 2.157 | V |
| | | V _{REFLO} | Ref Low | V _{SS} | V _{SS} | V _{SS} + 0.006 | V _{SS} + 0.024 | V |
| | RefPower = Med Opamp bias = High | V _{REFHI} | Ref High | 3.2 × Bandgap | 4.049 | 4.154 | 4.238 | V |
| | | V _{AGND} | AGND | 1.6 × Bandgap | 2.008 | 2.083 | 2.165 | V |
| | | V _{REFLO} | Ref Low | V _{SS} | V _{SS} | V _{SS} + 0.006 | V _{SS} + 0.026 | V |
| | RefPower = Med Opamp bias = Low | V _{REFHI} | Ref High | 3.2 × Bandgap | 4.047 | 4.154 | 4.238 | V |
| | | V _{AGND} | AGND | 1.6 × Bandgap | 2.016 | 2.081 | 2.150 | V |
| | | V _{REFLO} | Ref Low | V _{SS} | V _{SS} | V _{SS} + 0.004 | V _{SS} + 0.018 | V |

Table 22. 3.3-V DC Analog Reference Specifications

| Reference ARF_CR[5:3] | Reference Power Settings | Symbol | Reference | Description | Min | Typ | Max | Unit |
|-----------------------|--------------------------------------|--------------------|-----------|-------------------------------|-------------------------------|-------------------------------|-------------------------------|------|
| 0b000 | RefPower = High Opamp bias = High | V _{REFHI} | Ref High | V _{DD} /2 + Band-Gap | V _{DD} /2 + 1.225 | V _{DD} /2 + 1.292 | V _{DD} /2 + 1.361 | V |
| | | V _{AGND} | AGND | V _{DD} /2 | V _{DD} /2 – 0.067 | V _{DD} /2 – 0.002 | V _{DD} /2 + 0.063 | V |
| | | V _{REFLO} | Ref Low | V _{DD} /2 – Band-Gap | V _{DD} /2 – 1.35 | V _{DD} /2 – 1.293 | V _{DD} /2 – 1.210 | V |
| | RefPower = High Opamp bias = Low | V _{REFHI} | Ref High | V _{DD} /2 + Band-Gap | V _{DD} /2 + 1.218 | V _{DD} /2 + 1.294 | V _{DD} /2 + 1.370 | V |
| | | V _{AGND} | AGND | V _{DD} /2 | V _{DD} /2 – 0.038 | V _{DD} /2 – 0.001 | V _{DD} /2 + 0.035 | V |
| | | V _{REFLO} | Ref Low | V _{DD} /2 – Band-Gap | V _{DD} /2 – 1.329 | V _{DD} /2 – 1.296 | V _{DD} /2 – 1.259 | V |
| | RefPower = Med Opamp bias = High | V _{REFHI} | Ref High | V _{DD} /2 + Band-Gap | V _{DD} /2 + 1.221 | V _{DD} /2 + 1.294 | V _{DD} /2 + 1.366 | V |
| | | V _{AGND} | AGND | V _{DD} /2 | V _{DD} /2 – 0.050 | V _{DD} /2 – 0.002 | V _{DD} /2 + 0.046 | V |
| | | V _{REFLO} | Ref Low | V _{DD} /2 – Band-Gap | V _{DD} /2 – 1.331 | V _{DD} /2 – 1.296 | V _{DD} /2 – 1.260 | V |
| | RefPower = Med Opamp bias = Low | V _{REFHI} | Ref High | V _{DD} /2 + Band-Gap | V _{DD} /2 + 1.226 | V _{DD} /2 + 1.295 | V _{DD} /2 + 1.365 | V |
| | | V _{AGND} | AGND | V _{DD} /2 | V _{DD} /2 – 0.028 | V _{DD} /2 – 0.001 | V _{DD} /2 + 0.025 | V |
| | | V _{REFLO} | Ref Low | V _{DD} /2 – Band-Gap | V _{DD} /2 – 1.329 | V _{DD} /2 – 1.297 | V _{DD} /2 – 1.262 | V |

Table 22. 3.3-V DC Analog Reference Specifications (continued)

| Reference ARF_CR[5:3] | Reference Power Settings | Symbol | Reference | Description | Min | Typ | Max | Unit |
|-----------------------|--------------------------------------|--------------------|-----------|--|-----------------------------|-----------------------------|-----------------------------|------|
| 0b001 | RefPower = High Opamp bias = High | V _{REFHI} | Ref High | P2[4]+P2[6] (P2[4] = V _{DD} /2, P2[6] = 0.5 V) | P2[4] + P2[6] – 0.098 | P2[4] + P2[6] – 0.018 | P2[4] + P2[6] + 0.055 | V |
| | | V _{AGND} | AGND | P2[4] | P2[4] | P2[4] | P2[4] | – |
| | | V _{REFLO} | Ref Low | P2[4] – P2[6] (P2[4] = V _{DD} /2, P2[6] = 0.5 V) | P2[4] – P2[6] – 0.055 | P2[4] – P2[6] + 0.013 | P2[4] – P2[6] + 0.086 | V |
| | RefPower = High Opamp bias = Low | V _{REFHI} | Ref High | P2[4] + P2[6] (P2[4] = V _{DD} /2, P2[6] = 0.5 V) | P2[4] + P2[6] – 0.082 | P2[4] + P2[6] – 0.011 | P2[4] + P2[6] + 0.050 | V |
| | | V _{AGND} | AGND | P2[4] | P2[4] | P2[4] | P2[4] | – |
| | | V _{REFLO} | Ref Low | P2[4] – P2[6] (P2[4] = V _{DD} /2, P2[6] = 0.5 V) | P2[4] – P2[6] – 0.037 | P2[4] – P2[6] + 0.006 | P2[4] – P2[6] + 0.054 | V |
| | RefPower = Med Opamp bias = High | V _{REFHI} | Ref High | P2[4] + P2[6] (P2[4] = V _{DD} /2, P2[6] = 0.5 V) | P2[4] + P2[6] – 0.079 | P2[4] + P2[6] – 0.012 | P2[4] + P2[6] + 0.047 | V |
| | | V _{AGND} | AGND | P2[4] | P2[4] | P2[4] | P2[4] | – |
| | | V _{REFLO} | Ref Low | P2[4]–P2[6] (P2[4] = V _{DD} /2, P2[6] = 0.5 V) | P2[4] – P2[6] – 0.038 | P2[4] – P2[6] + 0.006 | P2[4] – P2[6] + 0.057 | V |
| | RefPower = Med Opamp bias = Low | V _{REFHI} | Ref High | P2[4]+P2[6] (P2[4] = V _{DD} /2, P2[6] = 0.5 V) | P2[4] + P2[6] – 0.080 | P2[4] + P2[6] – 0.008 | P2[4] + P2[6] + 0.055 | V |
| | | V _{AGND} | AGND | P2[4] | P2[4] | P2[4] | P2[4] | – |
| | | V _{REFLO} | Ref Low | P2[4]–P2[6] (P2[4] = V _{DD} /2, P2[6] = 0.5 V) | P2[4] – P2[6] – 0.032 | P2[4] – P2[6] + 0.003 | P2[4] – P2[6] + 0.042 | V |

Table 22. 3.3-V DC Analog Reference Specifications (continued)

| Reference ARF_CR[5:3] | Reference Power Settings | Symbol | Reference | Description | Min | Typ | Max | Unit |
|-----------------------|--|--------------------|-----------|--------------------|----------------------------|----------------------------|----------------------------|------|
| 0b010 | RefPower = High Opamp bias = High | V _{REFHI} | Ref High | V _{DD} | V _{DD} - 0.06 | V _{DD} - 0.010 | V _{DD} | V |
| | | V _{AGND} | AGND | V _{DD} /2 | V _{DD} /2 - 0.05 | V _{DD} /2 - 0.002 | V _{DD} /2 + 0.040 | V |
| | | V _{REFLO} | Ref Low | V _{SS} | V _{SS} | V _{SS} + 0.009 | V _{SS} + 0.056 | V |
| | RefPower = High Opamp bias = Low | V _{REFHI} | Ref High | V _{DD} | V _{DD} - 0.060 | V _{DD} - 0.006 | V _{DD} | V |
| | | V _{AGND} | AGND | V _{DD} /2 | V _{DD} /2 - 0.028 | V _{DD} /2 - 0.001 | V _{DD} /2 + 0.025 | V |
| | | V _{REFLO} | Ref Low | V _{SS} | V _{SS} | V _{SS} + 0.005 | V _{SS} + 0.034 | V |
| | RefPower = Med Opamp bias = High | V _{REFHI} | Ref High | V _{DD} | V _{DD} - 0.058 | V _{DD} - 0.008 | V _{DD} | V |
| | | V _{AGND} | AGND | V _{DD} /2 | V _{DD} /2 - 0.037 | V _{DD} /2 - 0.002 | V _{DD} /2 + 0.033 | V |
| | | V _{REFLO} | Ref Low | V _{SS} | V _{SS} | V _{SS} + 0.007 | V _{SS} + 0.046 | V |
| | RefPower = Med Opamp bias = Low | V _{REFHI} | Ref High | V _{DD} | V _{DD} - 0.057 | V _{DD} - 0.006 | V _{DD} | V |
| | | V _{AGND} | AGND | V _{DD} /2 | V _{DD} /2 - 0.025 | V _{DD} /2 - 0.001 | V _{DD} /2 + 0.022 | V |
| | | V _{REFLO} | Ref Low | V _{SS} | V _{SS} | V _{SS} + 0.004 | V _{SS} + 0.030 | V |
| 0b011 | All power settings. Not allowed for 3.3 V | - | - | - | - | - | - | |
| 0b100 | All power settings. Not allowed for 3.3 V | - | - | - | - | - | - | |

Table 22. 3.3-V DC Analog Reference Specifications (continued)

| Reference ARF_CR[5:3] | Reference Power Settings | Symbol | Reference | Description | Min | Typ | Max | Unit |
|-----------------------|---|--------------------|-----------|---|-----------------|-------------------------|-------------------------|------|
| 0b101 | RefPower = High Opamp bias = High | V _{REFHI} | Ref High | P2[4] + Band-Gap (P2[4] = V _{DD} /2) | P2[4] + 1.213 | P2[4] + 1.291 | P2[4] + 1.367 | V |
| | | V _{AGND} | AGND | P2[4] | P2[4] | P2[4] | P2[4] | V |
| | | V _{REFLO} | Ref Low | P2[4] – Band-Gap (P2[4] = V _{DD} /2) | P2[4] – 1.333 | P2[4] – 1.294 | P2[4] – 1.208 | V |
| | RefPower = High Opamp bias = Low | V _{REFHI} | Ref High | P2[4] + Band-Gap (P2[4] = V _{DD} /2) | P2[4] + 1.217 | P2[4] + 1.294 | P2[4] + 1.368 | V |
| | | V _{AGND} | AGND | P2[4] | P2[4] | P2[4] | P2[4] | V |
| | | V _{REFLO} | Ref Low | P2[4] – Band-Gap (P2[4] = V _{DD} /2) | P2[4] – 1.320 | P2[4] – 1.296 | P2[4] – 1.261 | V |
| | RefPower = Med Opamp bias = High | V _{REFHI} | Ref High | P2[4] + Band-Gap (P2[4] = V _{DD} /2) | P2[4] + 1.217 | P2[4] + 1.294 | P2[4] + 1.369 | V |
| | | V _{AGND} | AGND | P2[4] | P2[4] | P2[4] | P2[4] | V |
| | | V _{REFLO} | Ref Low | P2[4] – Band-Gap (P2[4] = V _{DD} /2) | P2[4] – 1.322 | P2[4] – 1.297 | P2[4] – 1.262 | V |
| | RefPower = Med Opamp bias = Low | V _{REFHI} | Ref High | P2[4] + Band-Gap (P2[4] = V _{DD} /2) | P2[4] + 1.219 | P2[4] + 1.295 | P2[4] + 1.37 | V |
| | | V _{AGND} | AGND | P2[4] | P2[4] | P2[4] | P2[4] | V |
| | | V _{REFLO} | Ref Low | P2[4] – Band-Gap (P2[4] = V _{DD} /2) | P2[4] – 1.324 | P2[4] – 1.297 | P2[4] – 1.262 | V |
| 0b110 | RefPower = High Opamp bias = High | V _{REFHI} | Ref High | 2 × BandGap | 2.507 | 2.598 | 2.698 | V |
| | | V _{AGND} | AGND | BandGap | 1.203 | 1.307 | 1.424 | V |
| | | V _{REFLO} | Ref Low | V _{ss} | V _{ss} | V _{ss} + 0.012 | V _{ss} + 0.067 | V |
| | RefPower = High Opamp bias = Low | V _{REFHI} | Ref High | 2 × BandGap | 2.516 | 2.598 | 2.683 | V |
| | | V _{AGND} | AGND | BandGap | 1.241 | 1.303 | 1.376 | V |
| | | V _{REFLO} | Ref Low | V _{ss} | V _{ss} | V _{ss} + 0.007 | V _{ss} + 0.040 | V |
| | RefPower = Med Opamp bias = High | V _{REFHI} | Ref High | 2 × BandGap | 2.510 | 2.599 | 2.693 | V |
| | | V _{AGND} | AGND | BandGap | 1.240 | 1.305 | 1.374 | V |
| | | V _{REFLO} | Ref Low | V _{ss} | V _{ss} | V _{ss} + 0.008 | V _{ss} + 0.048 | V |
| | RefPower = Med Opamp bias = Low | V _{REFHI} | Ref High | 2 × BandGap | 2.515 | 2.598 | 2.683 | V |
| | | V _{AGND} | AGND | BandGap | 1.258 | 1.302 | 1.355 | V |
| | | V _{REFLO} | Ref Low | V _{ss} | V _{ss} | V _{ss} + 0.005 | V _{ss} + 0.03 | V |
| 0b111 | All power settings. Not allowed for 3.3 V. | – | – | – | – | – | – | |

DC Analog External Reference Specifications

The following table lists guaranteed maximum and minimum specifications for the voltage and temperature ranges: 4.75 V to 5.25 V and $-40\text{ }^{\circ}\text{C} \leq T_A \leq 85\text{ }^{\circ}\text{C}$, or 3.0 V to 3.6 V and $-40\text{ }^{\circ}\text{C} \leq T_A \leq 85\text{ }^{\circ}\text{C}$, respectively. Typical parameters apply to 5 V and 3.3 V at 25 °C and are for design guidance only.

Table 23. 5-V DC Analog External Reference Specifications

| Reference | Description | Min | Typ | Max | Unit |
|-----------|--|-------|-------|-------|------|
| Ref Low | Ref Low = P2[4] – P2[6] (P2[4] = $V_{CC}/2$, P2[6] = 1.3 V) | 1.12 | 1.221 | 1.28 | V |
| AGND | AGND = P2[4] (P2[4] = $V_{CC}/2$) | 2.487 | 2.499 | 2.513 | V |
| Ref High | Ref Low = P2[4] + P2[6] (P2[4] = $V_{CC}/2$, P2[6] = 1.3 V) | 3.67 | 3.759 | 3.93 | V |

Table 24. 3.3-V DC Analog External Reference Specifications

| Reference | Description | Min | Typ | Max | Unit |
|-----------|--|-------|-------|-------|------|
| Ref Low | Ref Low = P2[4] – P2[6] (P2[4] = $V_{CC}/2$, P2[6] = 1.3 V) | 0.29 | 0.371 | 0.41 | V |
| AGND | AGND = P2[4] (P2[4] = $V_{CC}/2$) | 1.642 | 1.649 | 1.658 | V |
| Ref High | Ref Low = P2[4] + P2[6] (P2[4] = $V_{CC}/2$, P2[6] = 1.3 V) | – | 2.916 | – | V |

DC Analog PSoC Block Specifications

The following table lists guaranteed maximum and minimum specifications for the voltage and temperature ranges: 4.75 V to 5.25 V and $-40\text{ }^{\circ}\text{C} \leq T_A \leq 85\text{ }^{\circ}\text{C}$, or 3.0 V to 3.6 V and $-40\text{ }^{\circ}\text{C} \leq T_A \leq 85\text{ }^{\circ}\text{C}$, respectively. Typical parameters apply to 5 V and 3.3 V at 25 °C and are for design guidance only.

Table 25. DC Analog PSoC Block Specifications

| Symbol | Description | Min | Typ | Max | Unit | Notes |
|----------|---------------------------------------|-----|------|-----|------------|-------|
| R_{CT} | Resistor unit value (continuous time) | – | 12.2 | – | k Ω | |
| C_{SC} | Capacitor unit value (switch cap) | – | 80 | – | fF | |

DC POR, SMP, and LVD Specifications

The following table lists guaranteed maximum and minimum specifications for the voltage and temperature ranges: 4.75 V to 5.25 V and $-40\text{ }^{\circ}\text{C} \leq T_A \leq 85\text{ }^{\circ}\text{C}$, or 3.0

V to 3.6 V and $-40\text{ }^{\circ}\text{C} \leq T_A \leq 85\text{ }^{\circ}\text{C}$, respectively. Typical parameters apply to 5 V and 3.3 V at 25 °C and are for design guidance only.

Table 26. DC POR, SMP, and LVD Specifications

| Symbol | Description | Min | Typ | Max | Units | Notes |
|--------------|---|------|------|----------------------|-------|-------|
| V_{PPOR0R} | V_{DD} value for PPOR trip (positive ramp) PORLEV[1:0] = 00b | | 2.91 | | V | |
| V_{PPOR1R} | PORLEV[1:0] = 01b | – | 4.39 | – | V | |
| V_{PPOR2R} | PORLEV[1:0] = 10b | | 4.55 | | V | |
| V_{PPOR0} | V_{DD} value for PPOR trip (negative ramp) PORLEV[1:0] = 00b | | 2.82 | | V | |
| V_{PPOR1} | PORLEV[1:0] = 01b | – | 4.39 | – | V | |
| V_{PPOR2} | PORLEV[1:0] = 10b | | 4.55 | | V | |
| V_{PH0} | PPOR hysteresis PORLEV[1:0] = 00b | – | 92 | – | mV | |
| V_{PH1} | PORLEV[1:0] = 01b | – | 0 | – | mV | |
| V_{PH2} | PORLEV[1:0] = 10b | – | 0 | – | mV | |
| V_{LVD0} | V_{DD} value for LVD trip VM[2:0] = 000b | 2.86 | 2.92 | 2.98 ^[16] | V | |
| V_{LVD1} | VM[2:0] = 001b | 2.96 | 3.02 | 3.08 | V | |
| V_{LVD2} | VM[2:0] = 010b | 3.07 | 3.13 | 3.20 | V | |
| V_{LVD3} | VM[2:0] = 011b | 3.92 | 4.00 | 4.08 | V | |
| V_{LVD4} | VM[2:0] = 100b | 4.39 | 4.48 | 4.57 | V | |
| V_{LVD5} | VM[2:0] = 101b | 4.55 | 4.64 | 4.74 ^[17] | V | |
| V_{LVD6} | VM[2:0] = 110b | 4.63 | 4.73 | 4.82 | V | |
| V_{LVD7} | VM[2:0] = 111b | 4.72 | 4.81 | 4.91 | V | |
| V_{PUMP0} | V_{DD} value for SMP trip VM[2:0] = 000b | 2.96 | 3.02 | 3.08 | V | |
| V_{PUMP1} | VM[2:0] = 001b | 3.03 | 3.10 | 3.16 | V | |
| V_{PUMP2} | VM[2:0] = 010b | 3.18 | 3.25 | 3.32 | V | |
| V_{PUMP3} | VM[2:0] = 011b | 4.11 | 4.19 | 4.28 | V | |
| V_{PUMP4} | VM[2:0] = 100b | 4.55 | 4.64 | 4.74 | V | |
| V_{PUMP5} | VM[2:0] = 101b | 4.63 | 4.73 | 4.82 | V | |
| V_{PUMP6} | VM[2:0] = 110b | 4.72 | 4.82 | 4.91 | V | |
| V_{PUMP7} | VM[2:0] = 111b | 4.90 | 5.00 | 5.10 | V | |

Notes

16. Always greater than 50 mV above PPOR (PORLEV = 00) for falling supply.
 17. Always greater than 50 mV above PPOR (PORLEV = 10) for falling supply.

DC Programming Specifications

The following table lists guaranteed maximum and minimum specifications for the voltage and temperature ranges: 4.75 V to 5.25 V and $-40\text{ }^{\circ}\text{C} \leq T_A \leq 85\text{ }^{\circ}\text{C}$, or 3.0 V to 3.6 V and $-40\text{ }^{\circ}\text{C} \leq T_A \leq 85\text{ }^{\circ}\text{C}$, respectively. Typical parameters apply to 5 V and 3.3 V at 25 °C and are for design guidance only.

Table 27. DC Programming Specifications

| Symbol | Description | Min | Typ | Max | Units | Notes |
|-----------------------|---|------------------------|-----|------------------------|-------|---|
| V _{DDP} | V _{DD} for programming and erase | 4.5 | 5 | 5.5 | V | This specification applies to the functional requirements of external programmer tools. |
| V _{DDL} | Low V _{DD} for verify | 3 | 3.1 | 3.2 | V | This specification applies to the functional requirements of external programmer tools. |
| V _{DDHV} | High V _{DD} for verify | 5.1 | 5.2 | 5.3 | V | This specification applies to the functional requirements of external programmer tools. |
| V _{DDIWRITE} | Supply voltage for flash write operation | 3.15 | | 5.25 | V | This specification applies to this device when it is executing internal flash writes. |
| I _{DDP} | Supply current during programming or verify | – | 10 | 30 | mA | |
| V _{ILP} | Input low voltage during programming or verify | – | – | 0.8 | V | |
| V _{IHP} | Input high voltage during programming or verify | 2.2 | – | – | V | |
| I _{ILP} | Input current when applying V _{ilp} to P1[0] or P1[1] during programming or verify | – | – | 0.2 | mA | Driving internal pull-down resistor |
| I _{IHP} | Input current when applying V _{ihp} to P1[0] or P1[1] during programming or verify | – | – | 1.5 | mA | Driving internal pull-down resistor |
| V _{OLV} | Output low voltage during programming or verify | – | – | V _{SS} + 0.75 | V | |
| V _{OHV} | Output high voltage during programming or verify | V _{DD} – 1.0 | – | V _{DD} | V | |
| Flash _{ENPB} | Flash endurance (per block) | 50,000 ^[18] | – | – | – | Erase/write cycles per block |
| Flash _{ENT} | Flash endurance (total) ^[19] | 1,800,000 | – | – | – | Erase/write cycles |
| Flash _{DR} | Flash data retention | 10 | – | – | Years | |

DC I²C Specifications

The following table lists guaranteed maximum and minimum specifications for the voltage and temperature ranges: 4.75 V to 5.25 V and $-40\text{ }^{\circ}\text{C} \leq T_A \leq 85\text{ }^{\circ}\text{C}$, or 3.0 V to 3.6 V and $-40\text{ }^{\circ}\text{C} \leq T_A \leq 85\text{ }^{\circ}\text{C}$, respectively. Typical parameters apply to 5 V and 3.3 V at 25 °C and are for design guidance only.

Table 28. DC I²C Specifications

| Parameter | Description | Min | Typ | Max | Units | Notes |
|------------------------------------|------------------|-----------------------|-----|------------------------|-------|-----------------------------------|
| V _{IL12C} ^[20] | Input low level | – | – | 0.3 × V _{DD} | V | 3.0 V ≤ V _{DD} ≤ 3.6 V |
| | | – | – | 0.25 × V _{DD} | V | 4.75 V ≤ V _{DD} ≤ 5.25 V |
| V _{IH12C} ^[20] | Input high level | 0.7 × V _{DD} | – | – | V | 3.0 V ≤ V _{DD} ≤ 5.25 V |
| V _{OL12C} | Output low level | – | – | 0.4 | V | at sink current of 3 mA |
| | | – | – | 0.6 | V | at sink current of 6 mA |

Notes

18. The 50,000 cycle flash endurance per block is only guaranteed if the flash is operating within one voltage range. Voltage ranges are 3.0 V to 3.6 V and 4.75 V to 5.25 V.

19. A maximum of 36 × 50,000 block endurance cycles is allowed. This may be balanced between operations on 36 × 1 blocks of 50,000 maximum cycles each, 36 × 2 blocks of 25,000 maximum cycles each, or 36 × 4 blocks of 12,500 maximum cycles each (to limit the total number of cycles to 36 × 50,000 and that no single block ever sees more than 50,000 cycles).

For the full industrial range, the user must employ a temperature sensor user module (FlashTemp) and feed the result to the temperature argument before writing. Refer to the Flash APIs application note [Design Aids – Reading and Writing PSoC® Flash – AN2015](#) for more information.

20. All GPIOs meet the DC GPIO V_{IL} and V_{IH} specifications found in the DC GPIO specifications sections. The I²C GPIO pins also meet the mentioned specs.

AC Electrical Characteristics

AC Chip-Level Specifications

The following table lists guaranteed maximum and minimum specifications for the voltage and temperature ranges: 4.75 V to 5.25 V and $-40\text{ }^{\circ}\text{C} \leq T_A \leq 85\text{ }^{\circ}\text{C}$, or 3.0 V to 3.6 V and $-40\text{ }^{\circ}\text{C} \leq T_A \leq 85\text{ }^{\circ}\text{C}$, respectively. Typical parameters apply to 5 V and 3.3 V at 25 °C and are for design guidance only.

Note See the individual user module datasheets for information on maximum frequencies for user modules.

Table 29. AC Chip-Level Specifications

| Symbol | Description | Min | Typ | Max | Units | Notes |
|------------------------------------|---|--------|--------|--------------------------|-------|---|
| F _{IMO24} ^[21] | Internal main oscillator (IMO) frequency for 24 MHz | 22.8 | 24 | 25.2 ^[22,23] | MHz | Trimmed for 5 V or 3.3 V operation using factory trim values. See Figure 11 on page 21 . SLIMO Mode = 0. |
| F _{IMO6} | IMO frequency for 6 MHz | 5.5 | 6 | 6.5 ^[22,23] | MHz | Trimmed for 5 V or 3.3 V operation using factory trim values. See Figure 11 on page 21 . SLIMO Mode = 1. |
| F _{CPU1} | CPU frequency (5 V Nominal) | 0.0914 | 24 | 25.2 ^[22] | MHz | SLIMO Mode = 0. |
| F _{CPU2} | CPU frequency (3.3 V Nominal) | 0.0914 | 12 | 12.6 ^[23] | MHz | SLIMO Mode = 0. |
| F _{48M} | Digital PSoC block frequency | 0 | 48 | 50.4 ^[22,24] | MHz | Refer to AC Digital Block Specifications on page 45 . |
| F _{24M} | Digital PSoC block frequency | 0 | 24 | 25.2 ^[24] | MHz | |
| F _{32K1} | Internal low speed oscillator frequency | 15 | 32 | 64 | kHz | |
| F _{32K2} | External crystal oscillator | – | 32.768 | – | kHz | Accuracy is capacitor and crystal dependent. 50% duty cycle |
| F _{32K_U} | Internal low speed oscillator (ILO) untrimmed frequency | 5 | – | 100 | kHz | After a reset and before the M8C starts to run, the ILO is not trimmed. See the System Resets section of the PSoC Technical Reference Manual for details on this timing |
| F _{PLL} | PLL frequency | – | 23.986 | – | MHz | A multiple (x732) of crystal frequency |
| T _{PLLSLEW} | PLL lock time | 0.5 | – | 10 | ms | |
| T _{PLLSLEWLOW} | PLL lock time for low gain setting | 0.5 | – | 50 | ms | |
| T _{OS} | External crystal oscillator startup to 1% | – | 250 | 500 | ms | |
| T _{OSACC} | External crystal oscillator startup to 100 ppm | – | 300 | 600 | ms | The crystal oscillator frequency is within 100 ppm of its final value by the end of the T _{OSACC} period. Correct operation assumes a properly loaded 1 μW maximum drive level 32.768 kHz crystal. 3.0 V ≤ V _{DD} ≤ 5.5 V, $-40\text{ }^{\circ}\text{C} \leq T_A \leq 85\text{ }^{\circ}\text{C}$. |
| T _{XRST} | External reset pulse width | 10 | – | – | μs | |
| DC _{24M} | 24 MHz duty cycle | 40 | 50 | 60 | % | |
| DC _{ILO} | Internal low speed oscillator duty cycle | 20 | 50 | 80 | % | |
| Step _{24M} | 24 MHz trim step size | – | 50 | – | kHz | |
| F _{out48M} | 48 MHz output frequency | 45.6 | 48.0 | 50.4 ^[22, 23] | MHz | Trimmed. Using factory trim values |
| F _{MAX} | Maximum frequency of signal on row input or row output. | – | – | 12.3 | MHz | |

Notes

21. **Errata:** When the device is operated within 0 °C to 70 °C, the frequency tolerance is reduced to ±2.5%, but if operated at extreme temperature (below 0 °C or above 70 °C), frequency tolerance deviates from ±2.5% to ±5%. For more information, see [Errata on page 63](#).

22. 4.75 V < V_{DD} < 5.25 V.

23. 3.0 V < V_{DD} < 3.6 V. See application note [Adjusting PSoC® Trims for 3.3 V and 2.7 V Operation – AN2012](#) for information on trimming for operation at 3.3 V.

24. See the individual user module datasheets for information on maximum frequencies for user modules

Table 29. AC Chip-Level Specifications (continued)

| Symbol | Description | Min | Typ | Max | Units | Notes |
|---------------------------|--|-----|-----|------|-------|---|
| SR _{POWER_UP} | Power supply slew rate | – | – | 250 | V/ms | V _{DD} slew rate during power-up |
| T _{POWERUP} [25] | Time from end of POR to CPU executing code | – | 16 | 100 | ms | Power-up from 0 V. See the System Resets section of the PSoC Technical Reference Manual |
| tjit_IMO [26] | 24 MHz IMO cycle-to-cycle jitter (RMS) | – | 200 | 700 | ps | N = 32 |
| | 24 MHz IMO long term N cycle-to-cycle jitter (RMS) | – | 300 | 900 | | |
| | 24 MHz IMO period jitter (RMS) | – | 100 | 400 | | |
| tjit_PLL [26] | 24 MHz IMO cycle-to-cycle jitter (RMS) | – | 200 | 800 | ps | N = 32 |
| | 24 MHz IMO long term N cycle-to-cycle jitter (RMS) | – | 300 | 1200 | | |
| | 24 MHz IMO period jitter (RMS) | – | 100 | 700 | | |

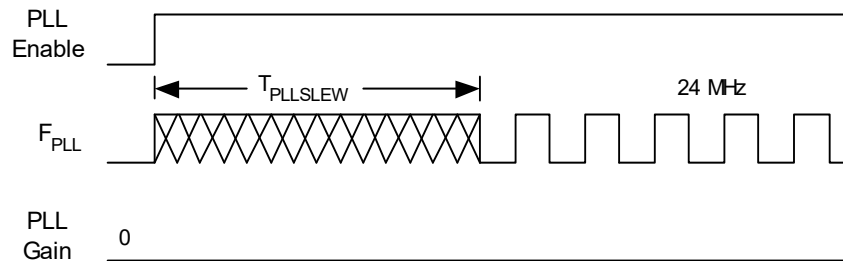
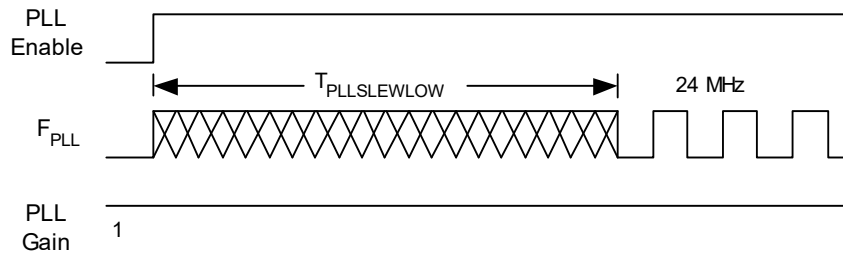
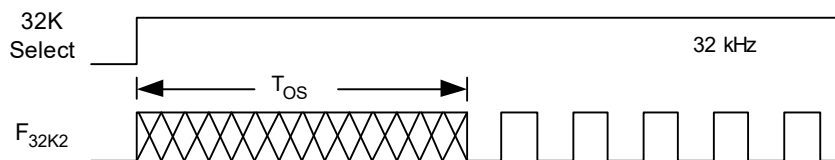
Figure 13. PLL Lock Timing Diagram

Figure 14. PLL Lock for Low Gain Setting Timing Diagram

Figure 15. External Crystal Oscillator Startup Timing Diagram

Notes

25. **Errata:** When V_{DD} of the device is pulled below ground just before power-on; the first read from each 8K Flash bank may be corrupted apart from Flash bank 0. This can be solved by doing a dummy read from each Flash bank prior to use of the Flash banks. For more information, see [Errata on page 63](#).

26. Refer to Cypress Jitter Specifications application note, [Understanding Datasheet Jitter Specifications for Cypress Timing Products – AN5054](#) for more information.

AC General Purpose I/O Specifications

The following table lists guaranteed maximum and minimum specifications for the voltage and temperature ranges: 4.75 V to 5.25 V and $-40\text{ }^{\circ}\text{C} \leq T_A \leq 85\text{ }^{\circ}\text{C}$, or 3.0 V to 3.6 V and $-40\text{ }^{\circ}\text{C} \leq T_A \leq 85\text{ }^{\circ}\text{C}$, respectively. Typical parameters apply to 5 V and 3.3 V at 25 $^{\circ}\text{C}$ and are for design guidance only.

Table 30. AC GPIO Specifications

| Symbol | Description | Min | Typ | Max | Unit | Notes |
|--------------------|---|-----|-----|------|------|---|
| F_{GPIO} | GPIO operating frequency | 0 | – | 12.3 | MHz | Normal strong mode |
| t_{RiseF} | Rise time, normal strong mode, $C_{\text{load}} = 50\text{ pF}$ | 3 | – | 18 | ns | $V_{\text{DD}} = 4.75\text{ to }5.25\text{ V}$, 10% to 90% |
| t_{FallF} | Fall time, normal strong mode, $C_{\text{load}} = 50\text{ pF}$ | 2 | – | 18 | ns | $V_{\text{DD}} = 4.75\text{ to }5.25\text{ V}$, 10% to 90% |
| t_{RiseS} | Rise time, slow strong mode, $C_{\text{load}} = 50\text{ pF}$ | 10 | 27 | – | ns | $V_{\text{DD}} = 3\text{ to }5.25\text{ V}$, 10% to 90% |
| t_{FallS} | Fall time, slow strong mode, $C_{\text{load}} = 50\text{ pF}$ | 10 | 22 | – | ns | $V_{\text{DD}} = 3\text{ to }5.25\text{ V}$, 10% to 90% |

Figure 16. GPIO Timing Diagram

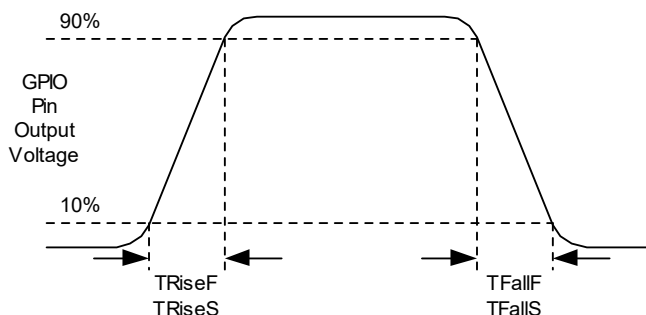

AC Operational Amplifier Specifications

The following tables list guaranteed maximum and minimum specifications for the voltage and temperature ranges: 4.75 V to 5.25 V and $-40\text{ }^{\circ}\text{C} \leq T_A \leq 85\text{ }^{\circ}\text{C}$, or 3.0 V to 3.6 V and $-40\text{ }^{\circ}\text{C} \leq T_A \leq 85\text{ }^{\circ}\text{C}$, respectively. Typical parameters apply to 5 V and 3.3 V at 25 $^{\circ}\text{C}$ and are for design guidance only.

Settling times, slew rates, and gain bandwidth are based on the analog continuous time PSoC block.

Power = High and Opamp bias = High is not supported at 3.3 V.

Table 31. 5-V AC Operational Amplifier Specifications

| Symbol | Description | Min | Typ | Max | Unit |
|--------------------------|--|--------------------|-------------|---------------------|--|
| t_{ROA} | Rising settling time to 0.1% for a 1 V step (10 pF load, unity gain) Power = Low, Opamp bias = Low Power = Medium, Opamp bias = High Power = High, Opamp bias = High | – – – | – – – | 3.9 0.72 0.62 | μs μs μs |
| t_{SOA} | Falling settling time to 0.1% for a 1 V step (10 pF load, unity gain) Power = Low, Opamp bias = Low Power = Medium, Opamp bias = High Power = High, Opamp bias = High | – – – | – – – | 5.9 0.92 0.72 | μs μs μs |
| SR_{ROA} | Rising slew rate (20% to 80%) of a 1 V step (10 pF load, unity gain) Power = Low, Opamp bias = Low Power = Medium, Opamp bias = High Power = High, Opamp bias = High | 0.15 1.7 6.5 | – – – | – – – | $\text{V}/\mu\text{s}$ $\text{V}/\mu\text{s}$ $\text{V}/\mu\text{s}$ |
| SR_{FOA} | Falling slew rate (20% to 80%) of a 1 V step (10 pF load, unity gain) Power = Low, Opamp bias = Low Power = Medium, Opamp bias = High Power = High, Opamp bias = High | 0.01 0.5 4.0 | – – – | – – – | $\text{V}/\mu\text{s}$ $\text{V}/\mu\text{s}$ $\text{V}/\mu\text{s}$ |
| BW_{OA} | Gain bandwidth product Power = Low, Opamp bias = Low Power = Medium, Opamp bias = High Power = High, Opamp bias = High | 0.75 3.1 5.4 | – – – | – – – | MHz MHz MHz |
| E_{NOA} | Noise at 1 kHz (Power = Medium, Opamp bias = High) | – | 100 | – | nV/rt-Hz |

Table 32. 3.3-V AC Operational Amplifier Specifications

| Symbol | Description | Min | Typ | Max | Units |
|------------|---|-------------|--------|--------------|--|
| t_{ROA} | Rising settling time to 0.1% of a 1 V Step (10 pF load, unity gain) Power = Low, Opamp bias = Low Power = Medium, Opamp bias = High | – – | – – | 3.92 0.72 | μs μs |
| t_{SOA} | Falling settling time to 0.1% of a 1 V Step (10 pF load, unity gain) Power = Low, Opamp bias = Low Power = Medium, Opamp bias = High | – – | – – | 5.41 0.72 | μs μs |
| SR_{ROA} | Rising slew rate (20% to 80%) of a 1 V Step (10 pF load, unity gain) Power = Low, Opamp bias = Low Power = Medium, Opamp bias = High | 0.31 2.7 | – – | – – | $\text{V}/\mu\text{s}$ $\text{V}/\mu\text{s}$ |
| SR_{FOA} | Falling slew rate (20% to 80%) of a 1 V Step (10 pF load, unity gain) Power = Low, Opamp bias = Low Power = Medium, Opamp bias = High | 0.24 1.8 | – – | – – | $\text{V}/\mu\text{s}$ $\text{V}/\mu\text{s}$ |
| BW_{OA} | Gain bandwidth product Power = Low, Opamp bias = Low Power = Medium, Opamp bias = High | 0.67 2.8 | – – | – – | MHz MHz |
| E_{NOA} | Noise at 1 kHz (Power = Medium, Opamp bias = High) | – | 100 | – | $\text{nV}/\text{rt-Hz}$ |

Figure 17. Typical Opamp Noise

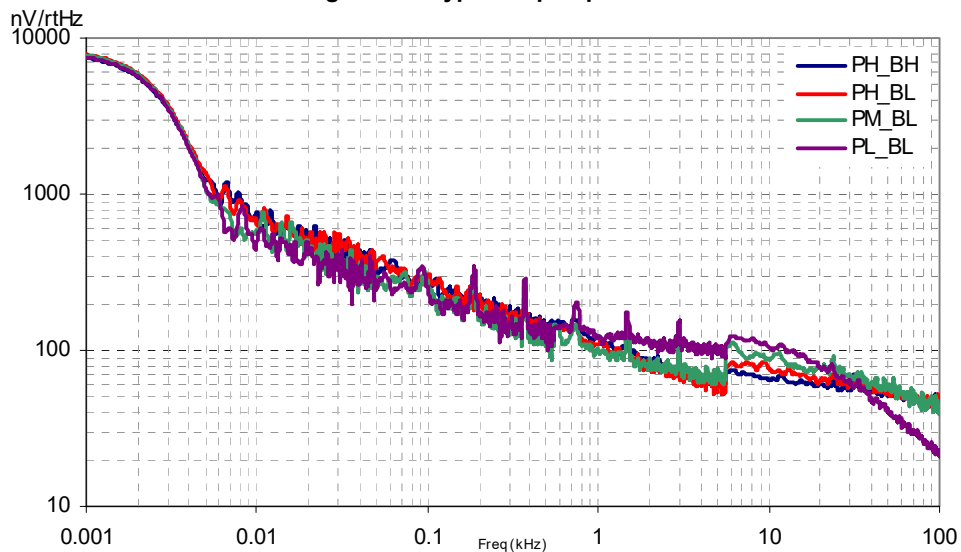

Analog Reference Noise spectrum:

When bypassed by a capacitor on P2[4], the noise of the analog ground signal distributed to each block is reduced by a factor of up to 5 (14 dB). This is at frequencies above the corner frequency defined by the on-chip 8.1 K resistance and the external capacitor.

Figure 18. Typical AGND Noise with P2[4] Bypass
AGND = 1.6 × V_{bg}

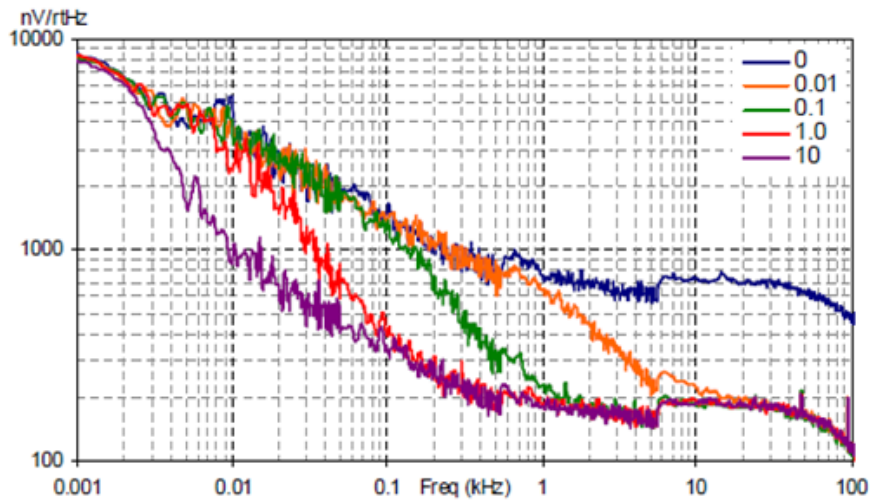

At low frequencies, the opamp noise is proportional to $1/f$, power independent, and determined by device geometry. At high frequencies, increased power level reduces the noise spectrum level.

Note: The capacitor values shown in Figure 18 are in μF .

AC Low-Power Comparator Specifications

The following table lists guaranteed maximum and minimum specifications for the voltage and temperature ranges: 4.75 V to 5.25 V and $-40\text{ }^{\circ}\text{C} \leq T_A \leq 85\text{ }^{\circ}\text{C}$, 3.0 V to 3.6 V and $-40\text{ }^{\circ}\text{C} \leq T_A \leq 85\text{ }^{\circ}\text{C}$, or 2.4 V to 3.0 V and $-40\text{ }^{\circ}\text{C} \leq T_A \leq 85\text{ }^{\circ}\text{C}$, respectively. Typical parameters apply to 5 V at 25 $^{\circ}\text{C}$ and are for design guidance only.

Table 33. AC Low-Power Comparator Specifications

| Symbol | Description | Min | Typ | Max | Unit | Notes |
|-------------------|-------------------|-----|-----|-----|---------------|---|
| t_{RLPC} | LPC response time | – | – | 50 | μs | $\geq 50\text{ mV}$ overdrive comparator reference set within V_{REFLPC} |

AC Digital Block Specifications

The following table lists guaranteed maximum and minimum specifications for the voltage and temperature ranges: 4.75 V to 5.25 V and $-40\text{ }^{\circ}\text{C} \leq T_A \leq 85\text{ }^{\circ}\text{C}$, or 3.0 V to 3.6 V and $-40\text{ }^{\circ}\text{C} \leq T_A \leq 85\text{ }^{\circ}\text{C}$, respectively. Typical parameters apply to 5 V and 3.3 V at 25 °C and are for design guidance only.

Table 34. AC Digital Block Specifications

| Function | Description | Min | Typ | Max | Unit | Notes |
|-------------------|--|--------------------|-----|------|------|--|
| All functions | Block input clock frequency | | | | | |
| | $V_{DD} \geq 4.75\text{ V}$ | – | – | 50.4 | MHz | |
| | $V_{DD} < 4.75\text{ V}$ | – | – | 25.2 | MHz | |
| Timer | Input clock frequency | | | | | |
| | No capture, $V_{DD} \geq 4.75\text{ V}$ | – | – | 50.4 | MHz | |
| | No capture, $V_{DD} < 4.75\text{ V}$ | – | – | 25.2 | MHz | |
| | With capture | – | – | 25.2 | MHz | |
| | Capture pulse width | 50 ^[27] | – | – | ns | |
| Counter | Input clock frequency | | | | | |
| | No enable input, $V_{DD} \geq 4.75\text{ V}$ | – | – | 50.4 | MHz | |
| | No enable input, $V_{DD} < 4.75\text{ V}$ | – | – | 25.2 | MHz | |
| | With enable input | – | – | 25.2 | MHz | |
| | Enable input pulse width | 50 ^[27] | – | – | ns | |
| Dead Band | Kill pulse width | | | | | |
| | Asynchronous restart mode | 20 | – | – | ns | |
| | Synchronous restart mode | 50 ^[27] | – | – | ns | |
| | Disable mode | 50 ^[27] | – | – | ns | |
| | Input clock frequency | | | | | |
| | $V_{DD} \geq 4.75\text{ V}$ | – | – | 50.4 | MHz | |
| | $V_{DD} < 4.75\text{ V}$ | – | – | 25.2 | MHz | |
| CRCPRS (PRS Mode) | Input clock frequency | | | | | |
| | $V_{DD} \geq 4.75\text{ V}$ | – | – | 50.4 | MHz | |
| | $V_{DD} < 4.75\text{ V}$ | – | – | 25.2 | MHz | |
| CRCPRS (CRC Mode) | Input clock frequency | – | – | 25.2 | MHz | |
| SPIM | Input clock frequency | – | – | 8.2 | MHz | The SPI serial clock (SCLK) frequency is equal to the input clock frequency divided by 2 |
| SPIS | Input clock (SCLK) frequency | – | – | 4.1 | MHz | The input clock is the SPI SCLK in SPIS mode |
| | Width of SS_negated between transmissions | 50 ^[27] | – | – | ns | |
| Transmitter | Input clock frequency | | | | | The baud rate is equal to the input clock frequency divided by 8 |
| | $V_{DD} \geq 4.75\text{ V}$, 2 stop bits | – | – | 50.4 | MHz | |
| | $V_{DD} \geq 4.75\text{ V}$, 1 stop bit | – | – | 25.2 | MHz | |
| | $V_{DD} < 4.75\text{ V}$ | – | – | 25.2 | MHz | |
| Receiver | Input clock frequency | | | | | The baud rate is equal to the input clock frequency divided by 8 |
| | $V_{DD} \geq 4.75\text{ V}$, 2 stop bits | – | – | 50.4 | MHz | |
| | $V_{DD} \geq 4.75\text{ V}$, 1 stop bit | – | – | 25.2 | MHz | |
| | $V_{DD} < 4.75\text{ V}$ | – | – | 25.2 | MHz | |

Note

27. 50 ns minimum input pulse width is based on the input synchronizers running at 24 MHz (42 ns nominal period).

AC Analog Output Buffer Specifications

The following tables list guaranteed maximum and minimum specifications for the voltage and temperature ranges: 4.75 V to 5.25 V and $-40\text{ }^{\circ}\text{C} \leq T_A \leq 85\text{ }^{\circ}\text{C}$, or 3.0 V to 3.6 V and $-40\text{ }^{\circ}\text{C} \leq T_A \leq 85\text{ }^{\circ}\text{C}$, respectively. Typical parameters apply to 5 V and 3.3 V at 25 °C and are for design guidance only.

Table 35. 5-V AC Analog Output Buffer Specifications

| Symbol | Description | Min | Typ | Max | Unit |
|------------|---|------|-----|-----|------------------|
| t_{ROB} | Rising settling time to 0.1%, 1 V Step, 100 pF load Power = Low Power = High | – | – | 4 | μs |
| | | – | – | 4 | μs |
| t_{SOB} | Falling settling time to 0.1%, 1 V step, 100 pF load Power = Low Power = High | – | – | 3.4 | μs |
| | | – | – | 3.4 | μs |
| SR_{ROB} | Rising slew rate (20% to 80%), 1 V step, 100 pF load Power = Low Power = High | 0.5 | – | – | V/ μs |
| | | 0.5 | – | – | V/ μs |
| SR_{FOB} | Falling slew rate (80% to 20%), 1 V step, 100 pF load Power = Low Power = High | 0.55 | – | – | V/ μs |
| | | 0.55 | – | – | V/ μs |
| BW_{OB} | Small signal bandwidth, 20 mV _{pp} , 3 dB BW, 100 pF load Power = Low Power = High | 0.8 | – | – | MHz |
| | | 0.8 | – | – | MHz |
| BW_{OB} | Large signal bandwidth, 1 V _{pp} , 3 dB BW, 100 pF load Power = Low Power = High | 300 | – | – | kHz |
| | | 300 | – | – | kHz |

Table 36. 3.3-V AC Analog Output Buffer Specifications

| Symbol | Description | Min | Typ | Max | Unit |
|------------|---|------|-----|-----|------------------|
| t_{ROB} | Rising settling time to 0.1%, 1 V Step, 100 pF load Power = Low Power = High | – | – | 4.7 | μs |
| | | – | – | 4.7 | μs |
| t_{SOB} | Falling settling time to 0.1%, 1 V Step, 100 pF load Power = Low Power = High | – | – | 4 | μs |
| | | – | – | 4 | μs |
| SR_{ROB} | Rising slew rate (20% to 80%), 1 V Step, 100 pF load Power = Low Power = High | 0.36 | – | – | V/ μs |
| | | 0.36 | – | – | V/ μs |
| SR_{FOB} | Falling slew rate (80% to 20%), 1 V Step, 100 pF load Power = Low Power = High | 0.40 | – | – | V/ μs |
| | | 0.40 | – | – | V/ μs |
| BW_{OB} | Small signal bandwidth, 20 mV _{pp} , 3 dB BW, 100 pF load Power = Low Power = High | 0.7 | – | – | MHz |
| | | 0.7 | – | – | MHz |
| BW_{OB} | Large signal bandwidth, 1 V _{pp} , 3 dB BW, 100 pF load Power = Low Power = High | 200 | – | – | kHz |
| | | 200 | – | – | kHz |

AC External Clock Specifications

The following tables list guaranteed maximum and minimum specifications for the voltage and temperature ranges: 4.75 V to 5.25 V and $-40\text{ }^{\circ}\text{C} \leq T_A \leq 85\text{ }^{\circ}\text{C}$, or 3.0 V to 3.6 V and $-40\text{ }^{\circ}\text{C} \leq T_A \leq 85\text{ }^{\circ}\text{C}$, respectively. Typical parameters apply to 5 V and 3.3 V at 25 °C and are for design guidance only.

Table 37. 5-V AC External Clock Specifications

| Symbol | Description | Min | Typ | Max | Unit |
|--------------|------------------------|-------|-----|------|---------------|
| F_{OSCEXT} | Frequency | 0.093 | – | 24.6 | MHz |
| – | High period | 20.6 | – | 5300 | ns |
| – | Low period | 20.6 | – | – | ns |
| – | Power-up IMO to switch | 150 | – | – | μs |

Table 38. 3.3-V AC External Clock Specifications

| Symbol | Description | Min | Typ | Max | Unit |
|---------------------|---|-------|-----|------|------|
| F _{OSCEXT} | Frequency with CPU clock divide by 1 | 0.093 | – | 12.3 | MHz |
| F _{OSCEXT} | Frequency with CPU clock divide by 2 or greater | 0.186 | – | 24.6 | MHz |
| – | High period with CPU clock divide by 1 | 41.7 | – | 5300 | ns |
| – | Low period with CPU clock divide by 1 | 41.7 | – | – | ns |
| – | Power-up IMO to switch | 150 | – | – | µs |

AC Programming Specifications

The following table lists guaranteed maximum and minimum specifications for the voltage and temperature ranges: 4.75 V to 5.25 V and $-40\text{ }^{\circ}\text{C} \leq T_A \leq 85\text{ }^{\circ}\text{C}$, or 3.0 V to 3.6 V and $-40\text{ }^{\circ}\text{C} \leq T_A \leq 85\text{ }^{\circ}\text{C}$, respectively. Typical parameters apply to 5 V and 3.3 V at 25 °C and are for design guidance only.

Table 39. AC Programming Specifications

| Symbol | Description | Min | Typ | Max | Unit | Notes |
|---------------------------|--|-----|-----|---------------------|------|--|
| t _{RSCLK} | Rise time of SCLK | 1 | – | 20 | ns | – |
| t _{FSCLK} | Fall time of SCLK | 1 | – | 20 | ns | – |
| t _{SSCLK} | Data setup time to falling edge of SCLK | 40 | – | – | ns | – |
| t _{HSCLK} | Data hold time from falling edge of SCLK | 40 | – | – | ns | – |
| F _{SCLK} | Frequency of SCLK | 0 | – | 8 | MHz | – |
| t _{ERASEB} | Flash erase time (block) | – | 10 | – | ms | – |
| t _{WRITE} | Flash block write time | – | 40 | – | ms | – |
| t _{DSCLK} | Data out delay from falling edge of SCLK | – | – | 45 | ns | V _{DD} > 3.6 |
| t _{DSCLK3} | Data out delay from falling edge of SCLK | – | – | 50 | ns | 3.0 ≤ V _{DD} ≤ 3.6 |
| t _{ERASEALL} | Flash erase time (Bulk) | – | 80 | – | ms | Erase all blocks and protection fields at once |
| t _{PROGRAM_HOT} | Flash block erase + Flash block write time | – | – | 100 ^[28] | ms | 0 °C ≤ T _j ≤ 100 °C |
| t _{PROGRAM_COLD} | Flash block erase + Flash block write time | – | – | 200 ^[28] | ms | –40 °C ≤ T _j ≤ 0 °C |

Note

28. For the full industrial range, you must employ a temperature sensor user module (FlashTemp) and feed the result to the temperature argument before writing. Refer to the Flash APIs application note [Design Aids – Reading and Writing PSoC® Flash – AN2015](#) for more information.

AC I²C Specifications

The following table lists guaranteed maximum and minimum specifications for the voltage and temperature ranges: 4.75 V to 5.25 V and $-40\text{ }^{\circ}\text{C} \leq T_A \leq 85\text{ }^{\circ}\text{C}$, or 3.0 V to 3.6 V and $-40\text{ }^{\circ}\text{C} \leq T_A \leq 85\text{ }^{\circ}\text{C}$, respectively. Typical parameters apply to 5 V and 3.3 V at 25 °C and are for design guidance only.

Table 40. AC Characteristics of the I²C SDA and SCL Pins

| Symbol | Description | Standard Mode | | Fast Mode | | Unit |
|-----------------------|--|---------------|-----|---------------------|-----|------|
| | | Min | Max | Min | Max | |
| F _{SCL I2C} | SCL clock frequency | 0 | 100 | 0 | 400 | kHz |
| T _{HDSTAI2C} | Hold time (repeated) START condition. After this period, the first clock pulse is generated. | 4.0 | – | 0.6 | – | μs |
| T _{LOWI2C} | LOW period of the SCL clock | 4.7 | – | 1.3 | – | μs |
| T _{HIGHI2C} | HIGH period of the SCL clock | 4.0 | – | 0.6 | – | μs |
| T _{SUSTAI2C} | Setup time for a repeated START condition | 4.7 | – | 0.6 | – | μs |
| T _{HDDATI2C} | Data hold time | 0 | – | 0 | – | μs |
| T _{SUDATI2C} | Data setup time | 250 | – | 100 ^[29] | – | ns |
| T _{SUSTOI2C} | Setup time for STOP condition | 4.0 | – | 0.6 | – | μs |
| T _{BUFI2C} | Bus free time between a STOP and START condition | 4.7 | – | 1.3 | – | μs |
| T _{SPI2C} | Pulse width of spikes are suppressed by the input filter. | – | – | 0 | 50 | ns |

Figure 19. Definition for Timing for Fast/Standard Mode on the I²C Bus

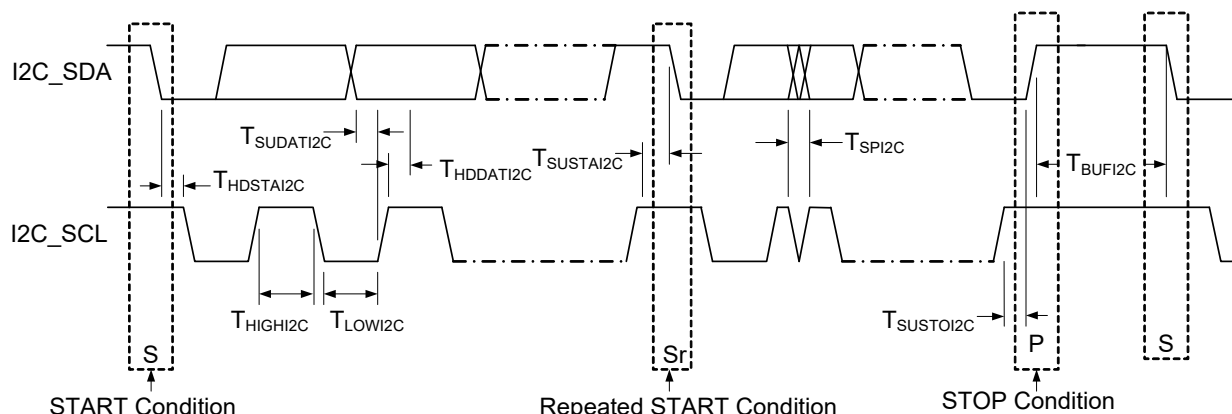

Note

29. A fast-mode I²C-bus device can be used in a standard-mode I²C-bus system, but the requirement $t_{SU,DAT} \geq 250\text{ ns}$ must then be met. This is the automatic case if the device does not stretch the LOW period of the SCL signal. If such device does stretch the LOW period of the SCL signal, it must output the next data bit to the SDA line $t_{rmax} + t_{SU,DAT} = 1000 + 250 = 1250\text{ ns}$ (according to the standard-mode I²C-bus specification) before the SCL line is released.

Packaging Information

This section illustrates the packaging specifications for the CY8C29x66 PSoC device, along with the thermal impedances for each package and the typical package capacitance on crystal pins.

Important Note Emulation tools may require a larger area on the target PCB than the chip's footprint. For a detailed description of the emulation tools' dimensions, refer to the emulator pod drawings at <http://www.cypress.com>.

Packaging Dimensions

Figure 20. 28-pin PDIP (300 Mils) Package Outline, 51-85014

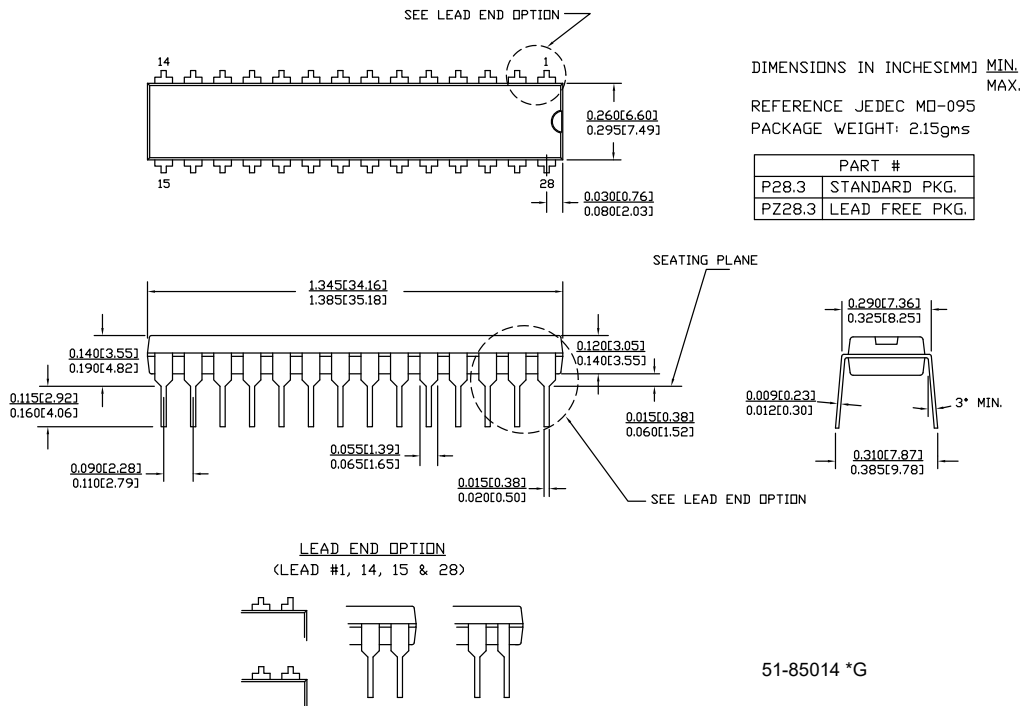

Figure 23. 44-pin TQFP (10 × 10 × 1.4 mm) Package Outline, 51-85064

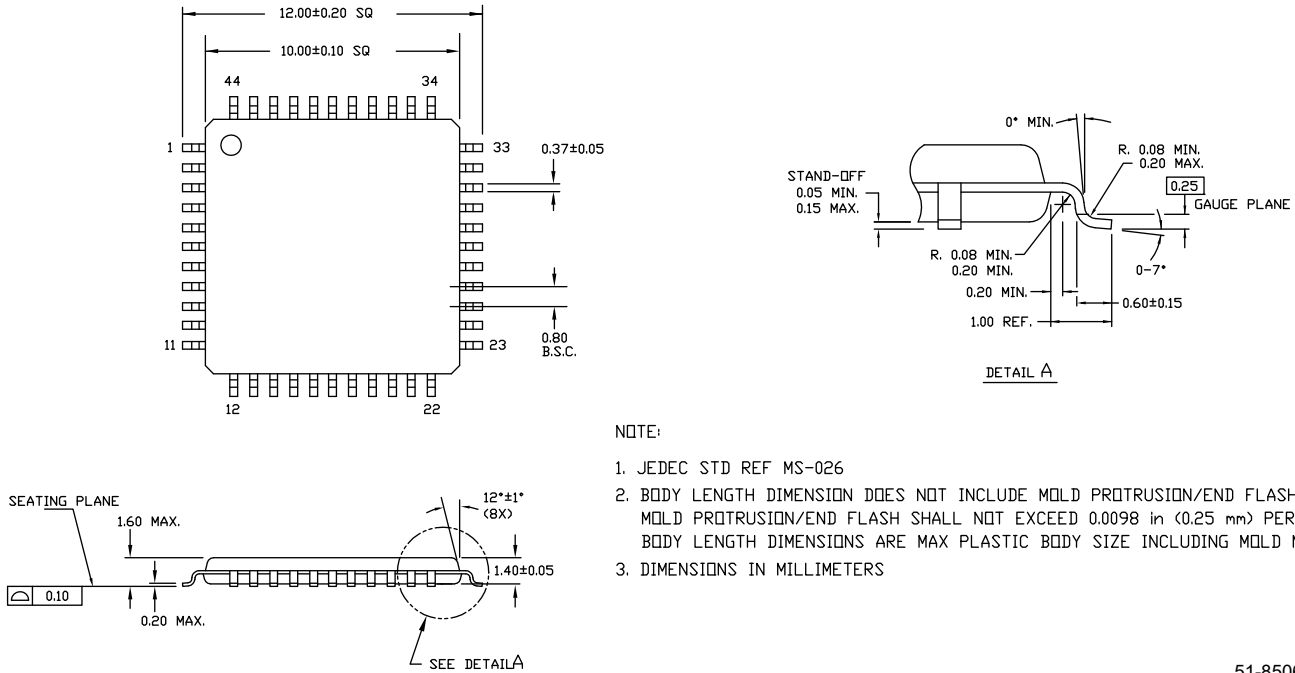

Figure 24. 48-pin SSOP (300 Mils) Package Outline, 51-85061

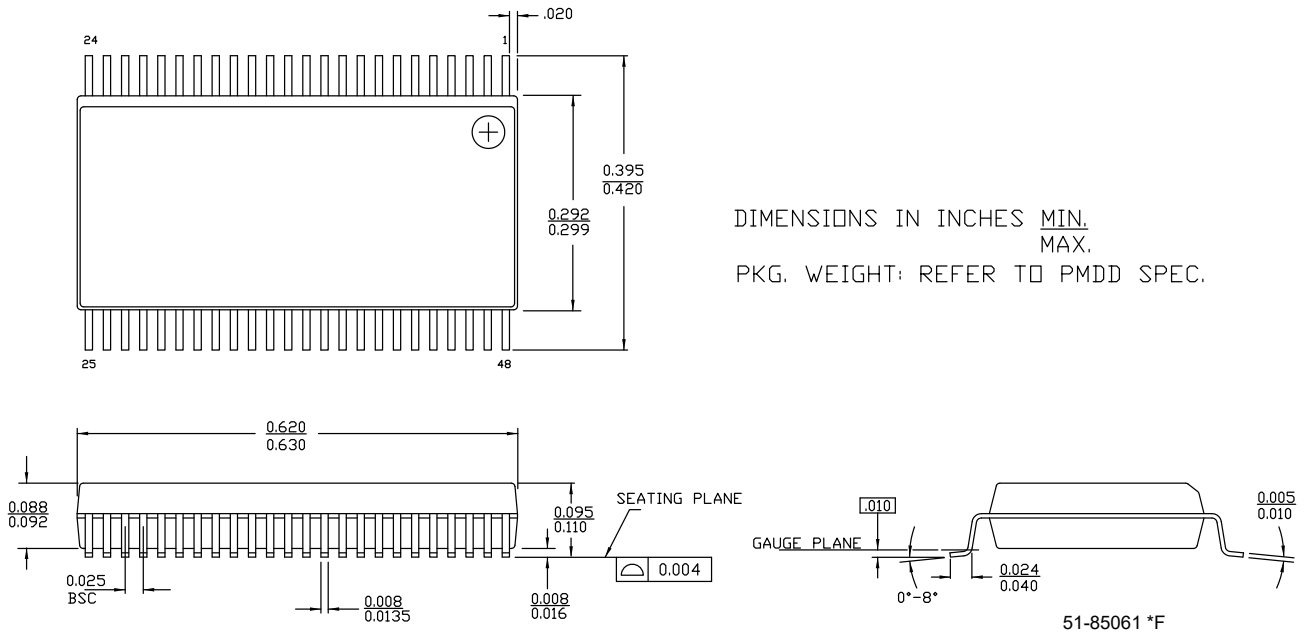
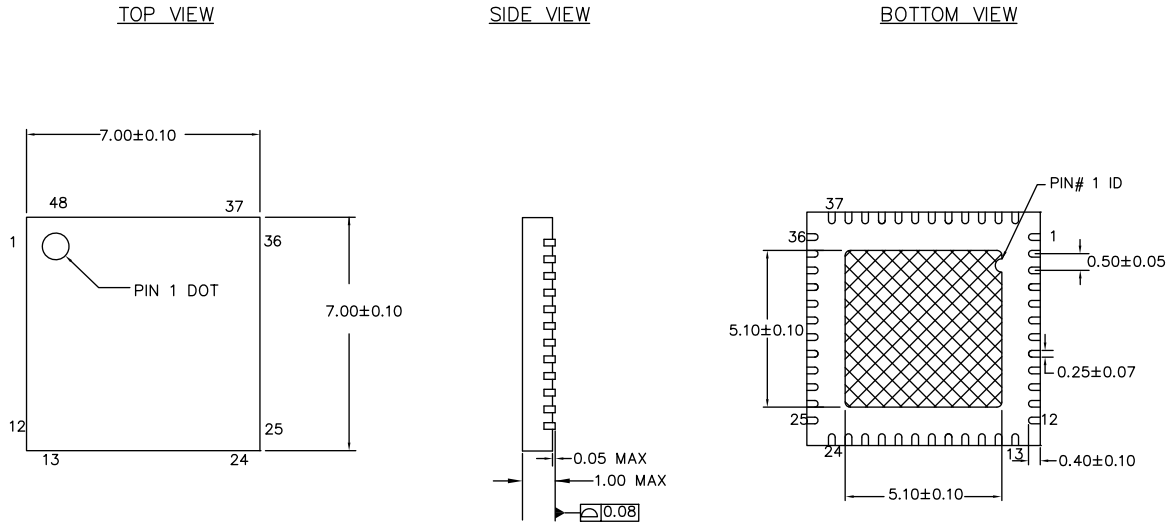

Figure 25. 48-pin QFN (7 × 7 × 1.0 mm) 5.1 × 5.1 E-Pad (Sawn) Package Outline, 001-13191



NOTES:

1. HATCH AREA IS SOLDERABLE EXPOSED METAL.
2. REFERENCE JEDEC#: MO-220
3. PACKAGE WEIGHT: 13 ± 1 mg

001-13191 *H

Figure 26. 100-pin TQFP (14 × 14 × 1.4 mm) Package Outline, 51-85048

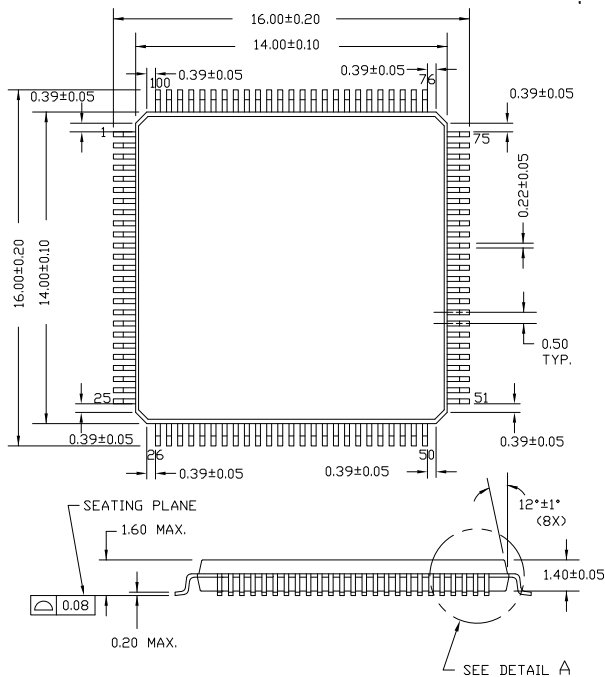

NOTE:

1. JEDEC STD REF MS-026
2. BODY LENGTH DIMENSION DOES NOT INCLUDE MOLD PROTRUSION/END FLASH
MOLD PROTRUSION/END FLASH SHALL NOT EXCEED 0.0098 in (0.25 mm) PER SIDE
BODY LENGTH DIMENSIONS ARE MAX PLASTIC BODY SIZE INCLUDING MOLD MISMATCH
3. DIMENSIONS IN MILLIMETERS

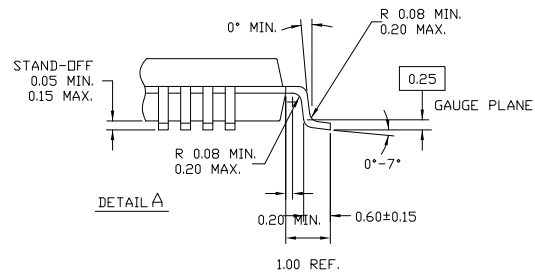

NOTE: PKG. CAN HAVE

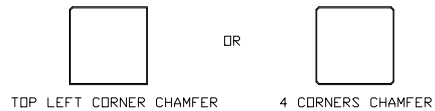

51-85048 *K

Important Note For information on the preferred dimensions for mounting the QFN packages, see the application note *Design Guidelines for Cypress Quad Flat No Extended Lead (QFN) Packaged Devices – AN72845* available at <http://www.cypress.com>.

Important Note Pinned vias for thermal conduction are not required for the low-power PSoC device.

Thermal Impedances

Table 41. Thermal Impedances per Package

| Package | Typical θ_{JA} ^[30] |
|----------------------------|---------------------------------------|
| 28-pin PDIP | 69 °C/W |
| 28-pin SSOP | 94 °C/W |
| 28-pin SOIC | 67 °C/W |
| 44-pin TQFP | 60 °C/W |
| 48-pin SSOP | 69 °C/W |
| 48-pin QFN ^[31] | 28 °C/W |
| 100-pin TQFP | 50 °C/W |

Capacitance on Crystal Pins

Table 42. Typical Package Capacitance on Crystal Pins

| Package | Package Capacitance |
|--------------|---------------------|
| 28-pin PDIP | 3.5 pF |
| 28-pin SSOP | 2.8 pF |
| 28-pin SOIC | 2.7 pF |
| 44-pin TQFP | 2.6 pF |
| 48-pin SSOP | 3.3 pF |
| 48-pin QFN | 1.8 pF |
| 100-pin TQFP | 3.1 pF |

Solder Reflow Specifications

Table 43 shows the solder reflow temperature limits that must not be exceeded.

Table 43. Solder Reflow Specifications

| Package | Maximum Peak Temperature (T _C) | Maximum Time above T _C – 5 °C |
|--------------|--|--|
| 28-pin PDIP | 260 °C | 30 seconds |
| 28-pin SSOP | 260 °C | 30 seconds |
| 28-pin SOIC | 260 °C | 30 seconds |
| 44-pin TQFP | 260 °C | 30 seconds |
| 48-pin SSOP | 260 °C | 30 seconds |
| 48-pin QFN | 260 °C | 30 seconds |
| 100-pin TQFP | 260 °C | 30 seconds |

Notes

30. $T_J = T_A + \text{POWER} \times \theta_{JA}$

31. To achieve the thermal impedance specified for the QFN package, refer to the application note *Design Guidelines for Cypress Quad Flat No Extended Lead (QFN) Packaged Devices – AN72845* available at <http://www.cypress.com>.

Development Tool Selection

This section presents the development tools available for all current PSoC device families including the CY8C29x66 family.

Software

PSoC Designer™

At the core of the PSoC development software suite is PSoC Designer, used to generate PSoC firmware applications. PSoC Designer is available free of charge at <http://www.cypress.com> and includes a free C compiler.

PSoC Programmer

Flexible enough to be used on the bench in development, yet suitable for factory programming, PSoC Programmer works either as a standalone programming application or it can operate directly from PSoC Designer or PSoC Express. PSoC Programmer software is compatible with both PSoC ICE-Cube In-Circuit Emulator and PSoC MiniProg. PSoC programmer is available free of charge at <http://www.cypress.com>.

Development Kits

All development kits can be purchased from the Cypress Online Store.

CY3215-DK Basic Development Kit

The **CY3215-DK** is for prototyping and development with PSoC Designer. This kit supports in-circuit emulation and the software interface allows users to run, halt, and single step the processor and view the content of specific memory locations. Advance emulation features also supported through PSoC Designer. The kit includes:

- PSoC Designer software CD
- ICE-Cube In-Circuit Emulator
- ICE Flex-Pod for CY8C29x66 family
- Cat-5 adapter
- Mini-Eval programming board
- 110 ~ 240 V power supply, Euro-Plug adapter
- iMAGEcraft C compiler
- ISSP cable
- USB 2.0 cable and Blue Cat-5 cable

Evaluation Tools

All evaluation tools can be purchased from the Cypress online store.

CY3210-MiniProg1

The **CY3210-MiniProg1** kit allows a user to program PSoC devices via the MiniProg1 programming unit. The MiniProg is a small, compact prototyping programmer that connects to the PC via a provided USB 2.0 cable. The kit includes:

- MiniProg programming unit
- MiniEval socket programming and evaluation board
- 28-pin CY8C27443-24PXI PDIP PSoC device sample
- PSoC Designer software CD
- Getting Started guide
- USB 2.0 cable

CY3210-PSoCEval1

The **CY3210-PSoCEval1** kit features an evaluation board and the MiniProg1 programming unit. The evaluation board includes an LCD module, potentiometer, LEDs, and plenty of bread-boarding space to meet all of your evaluation needs. The kit includes:

- Evaluation board with LCD module
- MiniProg programming unit
- PSoC Designer software CD
- Getting Started guide
- USB 2.0 cable

CY3214-PSoCEvalUSB

The **CY3214-PSoCEvalUSB** evaluation kit features a development board for the CY8C24794-24LFXI PSoC device. Special features of the board include both USB and capacitive sensing development and debugging support. This evaluation board also includes an LCD module, potentiometer, LEDs, an enunciator and plenty of bread boarding space to meet all of your evaluation needs. The kit includes:

- PSoCEvalUSB board
- LCD module
- MiniProg programming unit
- Mini USB cable
- PSoC Designer and example projects CD
- Getting Started guide
- Wire pack

Device Programmers

All device programmers can be purchased from the Cypress Online Store.

CY3216 Modular Programmer

The [CY3216 Modular Programmer kit](#) features a modular programmer and the MiniProg1 programming unit. The modular programmer includes three programming module cards and supports multiple Cypress products. The kit includes:

- Modular programmer base
- Three programming module cards
- MiniProg programming unit
- PSoC Designer software CD
- Getting Started guide
- USB 2.0 cable

CY3207ISSP In-System Serial Programmer (ISSP)

The [CY3207ISSP](#) is a production programmer. It includes protection circuitry and an industrial case that is more robust than the MiniProg in a production-programming environment.

Note CY3207ISSP needs special software and is not compatible with PSoC Programmer. The kit includes:

- CY3207 programmer unit
- PSoC ISSP software CD
- 110 ~ 240 V power supply, Euro-Plug adapter
- USB 2.0 cable

Accessories (Emulation and Programming)

Table 44. Emulation and Programming Accessories

| Part # | Pin Package | Flex-Pod Kit ^[32] | Foot Kit ^[33] | Adapter ^[34] |
|------------------|--------------|------------------------------|--------------------------|--|
| CY8C29466-24PVXI | 28-pin SSOP | CY3250-29XXX | CY3250-28SSOP-FK | Adapters can be found at http://www.emulation.com . |
| CY8C29466-24SXI | 28-pin SOIC | CY3250-29XXX | CY3250-28SOIC-FK | |
| CY8C29566-24AXI | 44-pin TQFP | CY3250-29XXX | CY3250-44TQFP-FK | |
| CY8C29666-24PVXI | 48-pin SSOP | CY3250-29XXX | CY3250-48SSOP-FK | |
| CY8C29666-24LTXI | 48-pin QFN | CY3250-29XXXQFN | CY3250-48QFN-FK | |
| CY8C29866-24AXI | 100-pin TQFP | CY3250-29XXX | CY3250-100TQFP-FK | |

Notes

32. Flex-Pod kit includes a practice flex-pod and a practice PCB, in addition to two flex-pods.

33. Foot kit includes surface mount feet that can be soldered to the target PCB.

34. Programming adapter converts non-DIP package to DIP footprint. Specific details and ordering information for each of the adapters can be found at <http://www.emulation.com>

Ordering Information

The following table lists the CY8C29x66 PSoC device's key package features and ordering codes.

| Package | Ordering Code | Flash (KB) | RAM (KB) | Switch Mode Pump | Temperature Range | Digital PSoC Blocks | Analog PSoC Blocks | Digital I/O Pins | Analog Inputs | Analog Outputs | XRES Pin |
|---------------------------------------|-------------------|------------|----------|------------------|-------------------|---------------------|--------------------|------------------|---------------|----------------|----------|
| 28-pin (210-mil) SSOP (Tape and Reel) | CY8C29466-24PVXIT | 32 | 2 | Yes | -40 °C to +85 °C | 16 | 12 | 24 | 12 | 4 | Yes |
| 28-pin (300-mil) SOIC | CY8C29466-24SXI | 32 | 2 | Yes | -40 °C to +85 °C | 16 | 12 | 24 | 12 | 4 | Yes |
| 28-pin (300-mil) SOIC (Tape and Reel) | CY8C29466-24SXIT | 32 | 2 | Yes | -40 °C to +85 °C | 16 | 12 | 24 | 12 | 4 | Yes |
| 44-pin TQFP | CY8C29566-24AXI | 32 | 2 | Yes | -40 °C to +85 °C | 16 | 12 | 40 | 12 | 4 | Yes |
| 44-pin TQFP (Tape and Reel) | CY8C29566-24AXIT | 32 | 2 | Yes | -40 °C to +85 °C | 16 | 12 | 40 | 12 | 4 | Yes |
| 48-pin (300-mil) SSOP | CY8C29666-24PVXI | 32 | 2 | Yes | -40 °C to +85 °C | 16 | 12 | 44 | 12 | 4 | Yes |
| 48-pin (300-mil) SSOP (Tape and Reel) | CY8C29666-24PVXIT | 32 | 2 | Yes | -40 °C to +85 °C | 16 | 12 | 44 | 12 | 4 | Yes |
| 100-Pin OCD TQFP ^[35] | CY8C29000-24AXI | 32 | 2 | Yes | -40 °C to +85 °C | 16 | 12 | 64 | 12 | 4 | Yes |
| 48-Pin (7 × 7 × 1.0 mm) QFN (Sawn) | CY8C29666-24LTXI | 32 | 2 | Yes | -40 °C to +85 °C | 16 | 12 | 44 | 12 | 4 | Yes |
| 48-Pin (7 × 7 × 1.0 mm) QFN (Sawn) | CY8C29666-24LTXIT | 32 | 2 | Yes | -40 °C to +85 °C | 16 | 12 | 44 | 12 | 4 | Yes |

Note For Die sales information, contact a local Cypress sales office or field applications engineer (FAE).

Ordering Code Definitions

CY 8 C 29 xxx-SPxx

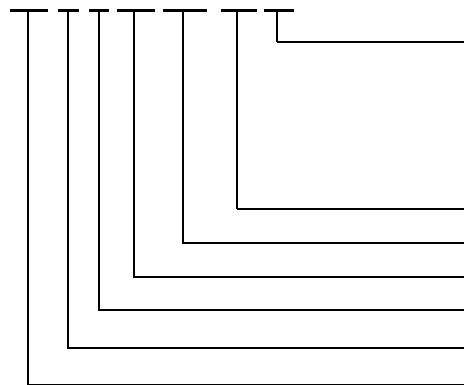

Package Type: Thermal Rating:
 PX = PDIP Pb-free C = Commercial
 SX = SOIC Pb-free I = Industrial
 PVX = SSOP Pb-free E = Extended
 LFX/LKX/LTX/LQX/LCX = QFN Pb-free
 AX = TQFP Pb-free
 Speed: 24 MHz
 Part Number
 Family Code
 Technology Code: C = CMOS
 Marketing Code: 8 = Cypress PSoC
 Company ID: CY = Cypress

Note

35. This part may be used for in-circuit debugging. It is NOT available for production.

Acronyms

Table 45 lists the acronyms that are used in this document.

Table 45. Acronyms Used in this Datasheet

| Acronym | Description | Acronym | Description |
|---------|---|-------------------|---|
| AC | alternating current | MIPS | million instructions per second |
| ADC | analog-to-digital converter | OCD | on-chip debug |
| API | application programming interface | PCB | printed circuit board |
| CMOS | complementary metal oxide semiconductor | PDIP | plastic dual-in-line package |
| CPU | central processing unit | PGA | programmable gain amplifier |
| CRC | cyclic redundancy check | PLL | phase-locked loop |
| CT | continuous time | POR | power on reset |
| DAC | digital-to-analog converter | PPOR | precision power on reset |
| DC | direct current | PRS | pseudo-random sequence |
| DTMF | dual-tone multi-frequency | PSoC [®] | Programmable System-on-Chip |
| ECO | external crystal oscillator | PWM | pulse width modulator |
| EEPROM | electrically erasable programmable read-only memory | QFN | quad flat no leads |
| GPIO | general purpose I/O | RTC | real time clock |
| ICE | in-circuit emulator | SAR | successive approximation |
| IDE | integrated development environment | SC | switched capacitor |
| ILO | internal low speed oscillator | SMP | switch mode pump |
| IMO | internal main oscillator | SOIC | small-outline integrated circuit |
| I/O | input/output | SPI | serial peripheral interface |
| IrDA | infrared data association | SRAM | static random access memory |
| ISSP | in-system serial programming | SROM | supervisory read only memory |
| LCD | liquid crystal display | SSOP | shrink small-outline package |
| LED | light-emitting diode | TQFP | thin quad flat pack |
| LPC | low power comparator | UART | universal asynchronous receiver / transmitter |
| LVD | low voltage detect | USB | universal serial bus |
| MAC | multiply-accumulate | WDT | watchdog timer |
| MCU | microcontroller unit | XRES | external reset |

Reference Documents

CY8CPLC20, CY8CLED16P01, CY8C29x66, CY8C27x43, CY8C24x94, CY8C24x23, CY8C24x23A, CY8C22x13, CY8C21x34, CY8C21x23, CY7C64215, CY7C603xx, CY8CNP1xx, and CYWUSB6953 PSoC[®] Programmable System-on-Chip Technical Reference Manual (TRM) (001-14463)

Design Aids – Reading and Writing PSoC[®] Flash - AN2015 (001-40459)

Design Guidelines for Cypress Quad Flat No Extended Lead (QFN) Packaged Devices – AN72845 available at <http://www.cypress.com>.

Document Conventions

Units of Measure

Table 46 lists the unit of measures.

Table 46. Units of Measure

| Symbol | Unit of Measure | Symbol | Unit of Measure |
|--------|-----------------|--------|-------------------------|
| dB | decibels | ms | millisecond |
| °C | degree Celsius | ns | nanosecond |
| fF | femto farad | ps | picosecond |
| pF | picofarad | μV | microvolts |
| kHz | kilohertz | mV | millivolts |
| MHz | megahertz | mVpp | millivolts peak-to-peak |
| rt-Hz | root hertz | nV | nanovolts |
| kΩ | kilohm | V | volts |
| Ω | ohm | μW | microwatts |
| μA | microampere | W | watt |
| mA | milliampere | mm | millimeter |
| nA | nanoampere | ppm | parts per million |
| pA | pikoampere | % | percent |
| μs | microsecond | | |

Numeric Conventions

Hexadecimal numbers are represented with all letters in uppercase with an appended lowercase 'h' (for example, '14h' or '3Ah'). Hexadecimal numbers may also be represented by a '0x' prefix, the C coding convention. Binary numbers have an appended lowercase 'b' (for example, '01010100b' or '01000011b'). Numbers not indicated by an 'h', 'b', or 0x are decimals.

Glossary

| | |
|---|---|
| active high | <ol style="list-style-type: none"> 1. A logic signal having its asserted state as the logic 1 state. 2. A logic signal having the logic 1 state as the higher voltage of the two states. |
| analog blocks | The basic programmable opamp circuits. These are SC (switched capacitor) and CT (continuous time) blocks. These blocks can be interconnected to provide ADCs, DACs, multi-pole filters, gain stages, and much more. |
| analog-to-digital (ADC) | A device that changes an analog signal to a digital signal of corresponding magnitude. Typically, an ADC converts a voltage to a digital number. The digital-to-analog (DAC) converter performs the reverse operation. |
| Application programming interface (API) | A series of software routines that comprise an interface between a computer application and lower level services and functions (for example, user modules and libraries). APIs serve as building blocks for programmers that create software applications. |
| asynchronous | A signal whose data is acknowledged or acted upon immediately, irrespective of any clock signal. |
| bandgap reference | A stable voltage reference design that matches the positive temperature coefficient of V_T with the negative temperature coefficient of V_{BE} , to produce a zero temperature coefficient (ideally) reference. |
| bandwidth | <ol style="list-style-type: none"> 1. The frequency range of a message or information processing system measured in hertz. 2. The width of the spectral region over which an amplifier (or absorber) has substantial gain (or loss); it is sometimes represented more specifically as, for example, full width at half maximum. |

Glossary (continued)

| | |
|-------------------------------|--|
| bias | <ol style="list-style-type: none">1. A systematic deviation of a value from a reference value.2. The amount by which the average of a set of values departs from a reference value.3. The electrical, mechanical, magnetic, or other force (field) applied to a device to establish a reference level to operate the device. |
| block | <ol style="list-style-type: none">1. A functional unit that performs a single function, such as an oscillator.2. A functional unit that may be configured to perform one of several functions, such as a digital PSoC block or an analog PSoC block. |
| buffer | <ol style="list-style-type: none">1. A storage area for data that is used to compensate for a speed difference, when transferring data from one device to another. Usually refers to an area reserved for IO operations, into which data is read, or from which data is written.2. A portion of memory set aside to store data, often before it is sent to an external device or as it is received from an external device.3. An amplifier used to lower the output impedance of a system. |
| bus | <ol style="list-style-type: none">1. A named connection of nets. Bundling nets together in a bus makes it easier to route nets with similar routing patterns.2. A set of signals performing a common function and carrying similar data. Typically represented using vector notation; for example, address[7:0].3. One or more conductors that serve as a common connection for a group of related devices. |
| clock | The device that generates a periodic signal with a fixed frequency and duty cycle. A clock is sometimes used to synchronize different logic blocks. |
| comparator | An electronic circuit that produces an output voltage or current whenever two input levels simultaneously satisfy predetermined amplitude requirements. |
| compiler | A program that translates a high level language, such as C, into machine language. |
| configuration space | In PSoC devices, the register space accessed when the XIO bit, in the CPU_F register, is set to '1'. |
| crystal oscillator | An oscillator in which the frequency is controlled by a piezoelectric crystal. Typically a piezoelectric crystal is less sensitive to ambient temperature than other circuit components. |
| cyclic redundancy check (CRC) | A calculation used to detect errors in data communications, typically performed using a linear feedback shift register. Similar calculations may be used for a variety of other purposes such as data compression. |
| data bus | A bi-directional set of signals used by a computer to convey information from a memory location to the central processing unit and vice versa. More generally, a set of signals used to convey data between digital functions. |
| debugger | A hardware and software system that allows you to analyze the operation of the system under development. A debugger usually allows the developer to step through the firmware one step at a time, set break points, and analyze memory. |
| dead band | A period of time when neither of two or more signals are in their active state or in transition. |
| digital blocks | The 8-bit logic blocks that can act as a counter, timer, serial receiver, serial transmitter, CRC generator, pseudo-random number generator, or SPI. |
| digital-to-analog (DAC) | A device that changes a digital signal to an analog signal of corresponding magnitude. The analog-to-digital (ADC) converter performs the reverse operation. |

Glossary (continued)

| | |
|---------------------------------|---|
| duty cycle | The relationship of a clock period high time to its low time, expressed as a percent. |
| emulator | Duplicates (provides an emulation of) the functions of one system with a different system, so that the second system appears to behave like the first system. |
| External Reset (XRES) | An active high signal that is driven into the PSoC device. It causes all operation of the CPU and blocks to stop and return to a pre-defined state. |
| Flash | An electrically programmable and erasable, non-volatile technology that provides you the programmability and data storage of EPROMs, plus in-system erasability. Non-volatile means that the data is retained when power is OFF. |
| Flash block | The smallest amount of Flash ROM space that may be programmed at one time and the smallest amount of Flash space that may be protected. A Flash block holds 64 bytes. |
| frequency | The number of cycles or events per unit of time, for a periodic function. |
| gain | The ratio of output current, voltage, or power to input current, voltage, or power, respectively. Gain is usually expressed in dB. |
| I ² C | A two-wire serial computer bus by Philips Semiconductors (now NXP Semiconductors). I ² C is an Inter-Integrated Circuit. It is used to connect low-speed peripherals in an embedded system. The original system was created in the early 1980s as a battery control interface, but it was later used as a simple internal bus system for building control electronics. I ² C uses only two bi-directional pins, clock and data, both running at +5 V and pulled high with resistors. The bus operates at 100 kbits/second in standard mode and 400 kbits/second in fast mode. |
| ICE | The in-circuit emulator that allows you to test the project in a hardware environment, while viewing the debugging device activity in a software environment (PSoC Designer). |
| input/output (I/O) | A device that introduces data into or extracts data from a system. |
| interrupt | A suspension of a process, such as the execution of a computer program, caused by an event external to that process, and performed in such a way that the process can be resumed. |
| interrupt service routine (ISR) | A block of code that normal code execution is diverted to when the M8C receives a hardware interrupt. Many interrupt sources may each exist with its own priority and individual ISR code block. Each ISR code block ends with the RETI instruction, returning the device to the point in the program where it left normal program execution. |
| jitter | <ol style="list-style-type: none">1. A misplacement of the timing of a transition from its ideal position. A typical form of corruption that occurs on serial data streams.2. The abrupt and unwanted variations of one or more signal characteristics, such as the interval between successive pulses, the amplitude of successive cycles, or the frequency or phase of successive cycles. |
| low-voltage detect (LVD) | A circuit that senses V_{DD} and provides an interrupt to the system when V_{DD} falls lower than a selected threshold. |
| M8C | An 8-bit Harvard-architecture microprocessor. The microprocessor coordinates all activity inside a PSoC by interfacing to the Flash, SRAM, and register space. |
| master device | A device that controls the timing for data exchanges between two devices. Or when devices are cascaded in width, the master device is the one that controls the timing for data exchanges between the cascaded devices and an external interface. The controlled device is called the slave device . |

Glossary (continued)

| | |
|-----------------------------|---|
| microcontroller | An integrated circuit chip that is designed primarily for control systems and products. In addition to a CPU, a microcontroller typically includes memory, timing circuits, and IO circuitry. The reason for this is to permit the realization of a controller with a minimal quantity of chips, thus achieving maximal possible miniaturization. This in turn, reduces the volume and the cost of the controller. The microcontroller is normally not used for general-purpose computation as is a microprocessor. |
| mixed-signal | The reference to a circuit containing both analog and digital techniques and components. |
| modulator | A device that imposes a signal on a carrier. |
| noise | <ol style="list-style-type: none">1. A disturbance that affects a signal and that may distort the information carried by the signal.2. The random variations of one or more characteristics of any entity such as voltage, current, or data. |
| oscillator | A circuit that may be crystal controlled and is used to generate a clock frequency. |
| parity | A technique for testing transmitting data. Typically, a binary digit is added to the data to make the sum of all the digits of the binary data either always even (even parity) or always odd (odd parity). |
| Phase-locked loop (PLL) | An electronic circuit that controls an oscillator so that it maintains a constant phase angle relative to a reference signal. |
| pinouts | The pin number assignment: the relation between the logical inputs and outputs of the PSoC device and their physical counterparts in the printed circuit board (PCB) package. Pinouts involve pin numbers as a link between schematic and PCB design (both being computer generated files) and may also involve pin names. |
| port | A group of pins, usually eight. |
| Power on reset (POR) | A circuit that forces the PSoC device to reset when the voltage is lower than a pre-set level. This is a type of hardware reset. |
| PSoC® | Cypress Semiconductor's PSoC® is a registered trademark and Programmable System-on-Chip™ is a trademark of Cypress. |
| PSoC Designer™ | The software for Cypress' Programmable System-on-Chip technology. |
| pulse width modulator (PWM) | An output in the form of duty cycle which varies as a function of the applied measurand |
| RAM | An acronym for random access memory. A data-storage device from which data can be read out and new data can be written in. |
| register | A storage device with a specific capacity, such as a bit or byte. |
| reset | A means of bringing a system back to a know state. See hardware reset and software reset. |
| ROM | An acronym for read only memory. A data-storage device from which data can be read out, but new data cannot be written in. |
| serial | <ol style="list-style-type: none">1. Pertaining to a process in which all events occur one after the other.2. Pertaining to the sequential or consecutive occurrence of two or more related activities in a single device or channel. |
| settling time | The time it takes for an output signal or value to stabilize after the input has changed from one value to another. |

Glossary (continued)

| | |
|----------------|---|
| shift register | A memory storage device that sequentially shifts a word either left or right to output a stream of serial data. |
| slave device | A device that allows another device to control the timing for data exchanges between two devices. Or when devices are cascaded in width, the slave device is the one that allows another device to control the timing of data exchanges between the cascaded devices and an external interface. The controlling device is called the master device. |
| SRAM | An acronym for static random access memory. A memory device where you can store and retrieve data at a high rate of speed. The term static is used because, after a value is loaded into an SRAM cell, it remains unchanged until it is explicitly altered or until power is removed from the device. |
| SROM | An acronym for supervisory read only memory. The SROM holds code that is used to boot the device, calibrate circuitry, and perform Flash operations. The functions of the SROM may be accessed in normal user code, operating from Flash. |
| stop bit | A signal following a character or block that prepares the receiving device to receive the next character or block. |
| synchronous | <ol style="list-style-type: none">1. A signal whose data is not acknowledged or acted upon until the next active edge of a clock signal.2. A system whose operation is synchronized by a clock signal. |
| tri-state | A function whose output can adopt three states: 0, 1, and Z (high-impedance). The function does not drive any value in the Z state and, in many respects, may be considered to be disconnected from the rest of the circuit, allowing another output to drive the same net. |
| UART | A UART or universal asynchronous receiver-transmitter translates between parallel bits of data and serial bits. |
| user modules | Pre-build, pre-tested hardware/firmware peripheral functions that take care of managing and configuring the lower level Analog and Digital PSoC Blocks. User Modules also provide high level API (Application Programming Interface) for the peripheral function. |
| user space | The bank 0 space of the register map. The registers in this bank are more likely to be modified during normal program execution and not just during initialization. Registers in bank 1 are most likely to be modified only during the initialization phase of the program. |
| V_{DD} | A name for a power net meaning “voltage drain.” The most positive power supply signal. Usually 5 V or 3.3 V. |
| V_{SS} | A name for a power net meaning “voltage source.” The most negative power supply signal. |
| watchdog timer | A timer that must be serviced periodically. If it is not serviced, the CPU resets after a specified period of time. |

Errata

This section describes the errata for the PSoC Programmable System-on-Chip, CY8C29xxx family of devices. Details include errata trigger conditions, scope of impact, available workaround, and silicon revision applicability. Contact your local Cypress Sales Representative if you have questions.

Part Numbers Affected

| Part Number | Ordering Information |
|-------------|----------------------|
| CY8C29xxx | CY8C29466-24PVXI |
| | CY8C29466-24PVXIT |
| | CY8C29466-24SXI |
| | CY8C29466-24SXIT |
| | CY8C29566-24AXI |
| | CY8C29566-24AXIT |
| | CY8C29666-24PVXI |
| | CY8C29666-24PVXIT |
| | CY8C29666-24LFXI |
| | CY8C29866-24AXI |
| | CY8C29000-24AXI |

Qualification Status

Product Status: In Production

Errata Summary

The following table defines the errata applicability to available CY8C29xxx family devices.

| Items | Part Number | Silicon Revision | Fix Status |
|--|-------------|------------------|--|
| [1]. Invalid Flash reads may occur if VDD is pulled to -0.5 V just before power-on | CY8C29xxx | A | No silicon fix is planned. Workaround is required. |
| [2]. Internal main oscillator (IMO) tolerance deviation at temperature extremes | CY8C29xxx | A | No silicon fix planned. Workaround is required. |

1. Invalid Flash reads may occur if VDD is pulled to -0.5 V just before power-on

■ Problem Definition

When V_{DD} of the device is pulled below ground just before power-on; the first read from each 8 K Flash bank may be corrupted. This issue does not affect Flash bank 0 because it is the selected bank upon reset.

■ Parameters Affected

When VDD is pulled below ground prior to power-on, an internal Flash reference may deviate from its nominal voltage. The reference deviation tends to result in the first Flash read from that bank returning 0xFF. During the first read from each bank, the reference is reset resulting in all future reads returning the correct value. A short delay of 5 μ s before the first real read provides time for the reference voltage to stabilize. When V_{DD} of the device is pulled below ground just before power-on; the first read from each 8K Flash bank may be corrupted apart from Flash bank 0. This can be solved by doing a dummy read from each Flash bank prior to use of the Flash banks.

■ Workaround

To prevent an invalid Flash read, a dummy read from each Flash bank must occur prior to use of the Flash banks. A delay of 5 μ s must occur after the dummy read and before a real read. The dummy reads should occur as soon as possible and must be located in Flash bank 0 prior to a read from any other Flash bank. An example for reading a byte of memory from each Flash bank is listed below and should be placed in boot.tpl and boot.asm immediately after the 'start:' label.

```
// dummy read from each 8 K Flash bank
```

```
// bank 1
mov A, 0x20    // MSB
mov X, 0x00    // LSB
romx
// bank 2
mov A, 0x40    // MSB
mov X, 0x00    // LSB
romx
// bank 3
mov A, 0x60    // MSB
mov X, 0x00    // LSB
romx
// wait at least 5 µs
mov X, 14
loop1:
dec X
jnz loop1
```

2. Internal main oscillator (IMO) tolerance deviation at temperature extremes

■ Problem Definition

Asynchronous digital communications interfaces may fail framing beyond 0 to 70 °C. This problem does not affect end-product usage between 0 and 70 °C.

■ Parameters Affected

The IMO frequency tolerance. The worst case deviation when operated below 0 °C and above +70 °C and within the upper and lower datasheet temperature range is ±5%.

■ Trigger Condition(S)

The asynchronous Rx/Tx clock source IMO frequency tolerance may deviate beyond the data sheet limit of ±2.5% when operated beyond the temperature range of 0 to +70 °C.

■ Scope of Impact

This problem may affect UART, IrDA, and FSK implementations.

■ Workaround

Implement a quartz crystal stabilized clock source on at least one end of the asynchronous digital communications interface.

■ Fix Status

Silicon fix is not planned. The workaround mentioned above should be used.

Document History Page

| Document Title: CY8C29466/CY8C29566/CY8C29666/CY8C29866, PSoC [®] Programmable System-on-Chip™ Document Number: 38-12013 | | | |
|--|---------|-----------------|--|
| Revision | ECN | Submission Date | Description of Change |
| ** | 131151 | 11/13/2003 | New document (Revision **). |
| *A | 132848 | 01/21/2004 | New information. First edition of preliminary datasheet. |
| *B | 133205 | 01/27/2004 | Changed part numbers, increased SRAM data storage to 2 K bytes. |
| *C | 133656 | 02/09/2004 | Changed part numbers and removed a 28-pin SOIC. |
| *D | 227240 | 06/10/04 | Changes to Overview section, 48-pin MLF pinout, and significant changes to the Electrical Specs. |
| *E | 240108 | See ECN | Added a 28-lead (300 mil) SOIC part. |
| *F | 247492 | See ECN | New information added to the Electrical Specifications chapter. |
| *G | 288849 | See ECN | Add DS standards, update device table, fine-tune pinouts, add Reflow Peak Temp. table. Finalize. |
| *H | 722736 | See ECN | Add QFN package clarifications. Add new QFN diagram. Add Low Power Comparator (LPC) AC/DC electrical spec. tables. Add CY8C20x34 to PSoC Device Characteristics table. Update emulation pod/feet kit part numbers. Add OCD non-production pinouts and package diagrams. Add ISSP note to pinout tables. Update package diagram revisions. Update typical and recommended Storage Temperature per industrial specs. Update CY branding and QFN convention. Add new Dev. Tool section. Update copyright and trademarks. |
| *I | 2503350 | See ECN | Pinout for CY8C29000 OCD wrongly included details of CY8C24X94. The correct pinout for CY8C29000 is included in this version. Added note on digital signaling in "DC Analog Reference Specifications" section. |
| *J | 2545030 | 07/29/08 | Added note to Ordering Information |
| *K | 2708295 | 04/22/2009 | Changed title from "CY8C29466, CY8C29566, CY8C29666, and CY8C29866 PSoC Mixed Signal Array Final datasheet" to "CY8C29466, CY8C29566, CY8C29666, and CY8C29866 PSoC [®] Programmable System-on-Chip™" Updated to datasheet template Added 48-Pin QFN (Sawn) package diagram and CY8C29666-24LTXI and CY8C29666-24LTXIT part details in the Ordering Information table Updated DC GPIO, AC Chip-Level, and AC Programming Specifications as follows: Modified F _{IMO6} (page 27), T _{WRITE} specifications (page 34) Added I _{OH} (page 21), I _{OL} (page 21), DC _{ILO} (page 28), F _{32K U} (page 27), T _{POWERUP} (page 28), T _{ERASEALL} (page 34), T _{PROGRAM_HOT} (page 34), and T _{PROGRAM_COLD} (page 34) specifications |
| *L | 2761941 | 09/10/2009 | Added SR _{POWER_UP} parameter in AC specs table. |
| *M | 2842762 | 01/08/2010 | Corrected Notes for V _{DD} parameter in Table 13, "DC Chip-Level Specifications," on page 22. Added "Contents" on page 3. Updated links in Sales, Solutions, and Legal Information. |
| *N | 2902396 | 03/30/2010 | Updated and content in Digital System Updated Cypress website links. Removed reference to PSoC Designer 4.4 in PSoC Designer Software Subsystems Added T _{BAKETEMP} and T _{BAKETIME} parameters in Absolute Maximum Ratings Updated AC Chip-Level Specifications Changed unit for SPIS function to ns in AC Digital Block Specifications Updated notes in Packaging Information and package diagrams. Updated Solder Reflow Specifications Updated Emulation and Programming Accessories Removed Third Party Tools and Build a PSoC Emulator into Your Board. Updated Ordering Information and Ordering Code Definitions. |

Document History Page (continued)

| Document Title: CY8C29466/CY8C29566/CY8C29666/CY8C29866, PSoC [®] Programmable System-on-Chip™ | | | |
|---|---------|-----------------|---|
| Document Number: 38-12013 | | | |
| Revision | ECN | Submission Date | Description of Change |
| *O | 2940410 | 05/31/2010 | Updated content to match current style guide and datasheet template. No technical updates. |
| *P | 3044869 | 10/01/2010 | Added PSoC Device Characteristics table . Added DC I ² C Specifications table. Added F _{32K_U} max limit. Added T _{jitter} IMO specification, removed existing jitter specifications. Updated Analog reference tables. Updated Units of Measure, Acronyms, Glossary, and References sections. Updated solder reflow specifications. No specific changes were made to AC Digital Block Specifications table and I ² C Timing Diagram. They were updated for clearer understanding. Updated Figure 13 since the labelling for y-axis was incorrect. Template and styles update. Removed footnote reference for “Solder Reflow Peak Temperature” table. |
| *Q | 3017427 | 11/08/10 | Removed the pruned part “CY8C29666-24LFXI” from the Ordering Information and Accessories (Emulation and Programming) . |
| *R | 3263978 | 05/23/11 | Updated Logic Block Diagram . Updated Solder Reflow Specifications . |
| *S | 3301676 | 07/04/11 | Fixed page numbering error on footer. |
| *T | 3358177 | 09/26/11 | Updated max value for '0b011' under Table 22 on page 33 . Updated V _{REFHI} values for '0b100' under Table 21 on page 29 . Incorrect flash/SRAM size mentioned under section PSoC Core on page 4 . Changed paragraph “Memory uses 16 KB of flash for program storage, 256 bytes of SRAM for data storage, and up to 2 KB of EEPROM emulated using the flash. Program flash uses four protection levels on blocks of 64 bytes, allowing customized software information protection (IP)” to “Memory uses 16 KB of flash for program storage, 256 bytes of SRAM for data storage, and up to 2 KB of EEPROM emulated using the flash. Program flash uses four protection levels on blocks of 64 bytes, allowing customized software information protection (IP)”. Removed package diagram spec 001-12919 as there is no MPN mapped to this package. The text “Pin must be left floating” is included under Description of NC pin in Table 6 on page 14 . |
| *U | 3598291 | 04/24/2012 | Changed the PWM description string from “8- to 32-bit” to “8- and 16-bit”. Updated package diagrams 001-13191 and 51-85048. |
| *V | 3991993 | 05/08/2013 | Updated Packaging Information : spec 51-85014 – Changed revision from *F to *G. spec 51-85061 – Changed revision from *E to *F. spec 001-13191 – Changed revision from *F to *G. Updated Reference Documents (Removed 001-17397 spec, 001-14503 spec related information). Added Errata . |

Document History Page (continued)

| Document Title: CY8C29466/CY8C29566/CY8C29666/CY8C29866, PSoC [®] Programmable System-on-Chip™ | | | |
|---|---------|-----------------|---|
| Document Number: 38-12013 | | | |
| Revision | ECN | Submission Date | Description of Change |
| *W | 4081641 | 07/31/2013 | <p>Added Errata footnotes (Note 1, 2, 14, 21, 25).</p> <p>Updated Features: Replaced “±2.5%” with “±5%”. Added Note 1 and referred the same note in ±5% under “Precision, programmable clocking”.</p> <p>Updated PSoC Functional Overview: Updated PSoC Core: Replaced “2.5%” with “5%” in 4th paragraph. Added Note 2 and referred the same note in 5%.</p> <p>Updated Electrical Specifications: Updated DC Electrical Characteristics: Updated DC Chip-Level Specifications: Added Note 14 and referred the same note in V_{DD} parameter. Updated AC Electrical Characteristics: Updated AC Chip-Level Specifications: Added Note 21 and referred the same note in F_{IMO24} parameter in Table 29. Replaced all instances of “24.6” with “25.2” in Table 29. Replaced all instances of “23.4” with “22.8” in Table 29. Replaced all instances of “49.2” with “50.4” in Table 29. Replaced “12.3” with “12.6” for maximum value of F_{CPU2} parameter in Table 29. Replaced “46.8” with “45.6” for minimum value of F_{out48M} parameter in Table 29. Added Note 25 and referred the same note in T_{POWERUP} parameter in Table 29. Updated AC Digital Block Specifications: Replaced all instances of “49.2” with “50.4” in Table 34. Replaced all instances of “24.6” with “25.2” in Table 34.</p> <p>Updated Packaging Information: spec 51-85026 – Changed revision from *F to *G. spec 51-85048 – Changed revision from *G to *H.</p> <p>Updated Errata.</p> <p>Updated in new template.</p> |
| *X | 4378144 | 05/13/2014 | <p>Updated Electrical Specifications: Updated AC Electrical Characteristics: Updated AC External Clock Specifications: Updated Table 37: Changed unit from “ms” to “µs” corresponding to “Power-up IMO to switch”.</p> <p>Updated Packaging Information: spec 51-85026 – Changed revision from *G to *H. spec 51-85064 – Changed revision from *E to *F. spec 51-85048 – Changed revision from *H to *I.</p> <p>Completing Sunset Review.</p> |

Document History Page (continued)

| Document Title: CY8C29466/CY8C29566/CY8C29666/CY8C29866, PSoC [®] Programmable System-on-Chip™ | | | |
|---|---------|-----------------|--|
| Document Number: 38-12013 | | | |
| Revision | ECN | Submission Date | Description of Change |
| *Y | 4461247 | 07/30/2014 | <p>Replaced references of “Application Notes for Surface Mount Assembly of Amkor’s MicroLeadFrame (MLF) Packages” with “Design Guidelines for Cypress Quad Flat No Extended Lead (QFN) Packaged Devices – AN72845” in all instances across the document.</p> <p>Added More Information.</p> <p>Added PSoC Designer.</p> <p>Removed “Getting Started”.</p> <p>Updated Electrical Specifications: Updated DC Electrical Characteristics: Updated DC I2C Specifications: Updated Table 28: Replaced V_{OH12C} with V_{OL12C}.</p> |
| *Z | 4479512 | 09/03/2014 | <p>Updated Electrical Specifications: Updated DC Electrical Characteristics: Added DC Analog External Reference Specifications. Updated AC Electrical Characteristics: Updated AC Operational Amplifier Specifications: Updated description. Updated Figure 18.</p> <p>Updated Errata: Updated Errata Summary: Updated details in “Fix Status” column in the table. Updated details in “Fix Status” bulleted point below the table.</p> |
| AA | 4622517 | 01/13/2015 | <p>Updated Pinouts: Updated 100-Pin Part Pinout: Updated Table 6: Added Note 10 and referred the same note in description of pin 15, pin 34, pin 65, pin 84 and pin 85. Updated 100-Pin Part Pinout (On-Chip Debug): Updated Table 7: Added Note 12 and referred the same note in description of pin 15, pin 34, pin 65, pin 84 and pin 85.</p> <p>Updated Packaging Information: spec 51-85079 – Changed revision from *E to *F.</p> |
| AB | 4882080 | 08/12/2015 | <p>Replaced “Flash pages” with “Flash banks” in all instances across the document. Updated Packaging Information: spec 001-13191 – Changed revision from *G to *H.</p> |
| AC | 5702069 | 04/19/2017 | <p>Updated Cypress logo. Updated Copyright. Updated the following Packaging Information: Figure 23 (spec 51-85064 *F to *G) Figure 26 (spec 51-85048 *I to *J)</p> |
| AD | 6882394 | 5/15/2020 | <p>Removed the MPN CY8C29466-24PXI, as this Part number is in EOL-Obsolete status in Oracle PLM.</p> <p>Updated Packaging Information: spec 51-85048– Changed revision from *J to *K.</p> |

Sales, Solutions, and Legal Information

Worldwide Sales and Design Support

Cypress maintains a worldwide network of offices, solution centers, manufacturer's representatives, and distributors. To find the office closest to you, visit us at [Cypress Locations](#).

Products

| | |
|---|--|
| Arm [®] Cortex [®] Microcontrollers | cypress.com/arm |
| Automotive | cypress.com/automotive |
| Clocks & Buffers | cyprmmess.com/clocks |
| Interface | cypress.com/interface |
| Internet of Things | cypress.com/iot |
| Memory | cypress.com/memory |
| Microcontrollers | cypress.com/mcu |
| PSoC | cypress.com/psoc |
| Power Management ICs | cypress.com/pmic |
| Touch Sensing | cypress.com/touch |
| USB Controllers | cypress.com/usb |
| Wireless Connectivity | cypress.com/wireless |

PSoC[®] Solutions

[PSoC 1](#) | [PSoC 3](#) | [PSoC 4](#) | [PSoC 5LP](#) | [PSoC 6 MCU](#)

Cypress Developer Community

[Community](#) | [Code Examples](#) | [Projects](#) | [Video](#) | [Blogs](#) | [Training](#) | [Components](#)

Technical Support

cypress.com/support

© Cypress Semiconductor Corporation, 2003-2020. This document is the property of Cypress Semiconductor Corporation and its subsidiaries ("Cypress"). This document, including any software or firmware included or referenced in this document ("Software"), is owned by Cypress under the intellectual property laws and treaties of the United States and other countries worldwide. Cypress reserves all rights under such laws and treaties and does not, except as specifically stated in this paragraph, grant any license under its patents, copyrights, trademarks, or other intellectual property rights. If the Software is not accompanied by a license agreement and you do not otherwise have a written agreement with Cypress governing the use of the Software, then Cypress hereby grants you a personal, non-exclusive, nontransferable license (without the right to sublicense) (1) under its copyright rights in the Software (a) for Software provided in source code form, to modify and reproduce the Software solely for use with Cypress hardware products, only internally within your organization, and (b) to distribute the Software in binary code form externally to end users (either directly or indirectly through resellers and distributors), solely for use on Cypress hardware product units, and (2) under those claims of Cypress's patents that are infringed by the Software (as provided by Cypress, unmodified) to make, use, distribute, and import the Software solely for use with Cypress hardware products. Any other use, reproduction, modification, translation, or compilation of the Software is prohibited.

TO THE EXTENT PERMITTED BY APPLICABLE LAW, CYPRESS MAKES NO WARRANTY OF ANY KIND, EXPRESS OR IMPLIED, WITH REGARD TO THIS DOCUMENT OR ANY SOFTWARE OR ACCOMPANYING HARDWARE, INCLUDING, BUT NOT LIMITED TO, THE IMPLIED WARRANTIES OF MERCHANTABILITY AND FITNESS FOR A PARTICULAR PURPOSE. No computing device can be absolutely secure. Therefore, despite security measures implemented in Cypress hardware or software products, Cypress shall have no liability arising out of any security breach, such as unauthorized access to or use of a Cypress product. CYPRESS DOES NOT REPRESENT, WARRANT, OR GUARANTEE THAT CYPRESS PRODUCTS, OR SYSTEMS CREATED USING CYPRESS PRODUCTS, WILL BE FREE FROM CORRUPTION, ATTACK, VIRUSES, INTERFERENCE, HACKING, DATA LOSS OR THEFT, OR OTHER SECURITY INTRUSION (collectively, "Security Breach"). Cypress disclaims any liability relating to any Security Breach, and you shall and hereby do release Cypress from any claim, damage, or other liability arising from any Security Breach. In addition, the products described in these materials may contain design defects or errors known as errata which may cause the product to deviate from published specifications. To the extent permitted by applicable law, Cypress reserves the right to make changes to this document without further notice. Cypress does not assume any liability arising out of the application or use of any product or circuit described in this document. Any information provided in this document, including any sample design information or programming code, is provided only for reference purposes. It is the responsibility of the user of this document to properly design, program, and test the functionality and safety of any application made of this information and any resulting product. "High-Risk Device" means any device or system whose failure could cause personal injury, death, or property damage. Examples of High-Risk Devices are weapons, nuclear installations, surgical implants, and other medical devices. "Critical Component" means any component of a High-Risk Device whose failure to perform can be reasonably expected to cause, directly or indirectly, the failure of the High-Risk Device, or to affect its safety or effectiveness. Cypress is not liable, in whole or in part, and you shall and hereby do release Cypress from any claim, damage, or other liability arising from any use of a Cypress product as a Critical Component in a High-Risk Device. You shall indemnify and hold Cypress, its directors, officers, employees, agents, affiliates, distributors, and assigns harmless from and against all claims, costs, damages, and expenses, arising out of any claim, including claims for product liability, personal injury or death, or property damage arising from any use of a Cypress product as a Critical Component in a High-Risk Device. Cypress products are not intended or authorized for use as a Critical Component in any High-Risk Device except to the limited extent that (i) Cypress's published data sheet for the product explicitly states Cypress has qualified the product for use in a specific High-Risk Device, or (ii) Cypress has given you advance written authorization to use the product as a Critical Component in the specific High-Risk Device and you have signed a separate indemnification agreement.

Cypress, the Cypress logo, Spansion, the Spansion logo, and combinations thereof, WICED, PSoC, CapSense, EZ-USB, F-RAM, and Traveo are trademarks or registered trademarks of Cypress in the United States and other countries. For a more complete list of Cypress trademarks, visit cypress.com. Other names and brands may be claimed as property of their respective owners.

Looking for pricing, stock, or lifecycle information?

Click below to explore more details on WIN SOURCE:

 [View CY8C29466-24SXIT on WIN SOURCE](#)

 [Infineon Technologies](#) Information

Optimize Your Supply Chain with WIN SOURCE Solutions

-  Global Sourcing Solution
-  Obsolete Management
-  Cost Control Management
-  Shortage Management
-  Alternative Solution
-  Excess Inventory Management