



**THE DATASHEET OF  
TP4057**



## Description

TP4057 is an excellent linear charger with constant current and constant voltage for single lithium ion battery. TP4057 is packaged in SOT23-6 package with less peripheral components, which makes it very suitable for portable products, and suitable for power supply of USB power supply and adapter power supply.

Based on the special internal MOSFET architecture and anti reverse charging circuit, TP4057 does not need external detection resistor and isolation diode. When the external environment temperature is too high or in high power applications, the thermal feedback can adjust the charging current to reduce the chip temperature. The charging voltage is fixed at 4.24 V, while the charging current can be set externally through a resistor. When the charging current drops to 1 / 10 of the set value after reaching the final floating charge voltage, the chip will terminate the charging cycle.

When the input voltage is disconnected, TP4057 will enter sleep state, and the battery leakage current will drop below 1uA. The TP4057 can be set to stop mode, when the static current of the chip drops to 25uA.

TP4057 also includes other features: battery temperature monitoring, undervoltage locking, automatic recharging and two status pins to show charging and charging termination.

## Features

- Programmable charging current 500mA
- No need for external MOSFET, resistance detection and isolation diode
- Complete linear charger with SOT23-6 package for single lithium battery
- Constant current / constant voltage operation with thermal regulation to maximize charging rate without risk of overheating.
- The accuracy reaches 4.24V precharge voltage with accuracy of  $\pm 1\%$
- Output of charging current monitor for battery power detection
- Automatic recharging
- Dual output of charging state, no battery and fault status display
- Charge termination of C / 10
- The static current in standby mode is 25ua
- 2.9v trickle charging
- Soft start current limiting

## Applications

- Mobile phone, PDA
- MP3 and MP4 players
- Charger
- Digital camera
- Electronic dictionary
- Bluetooth, GPS navigator
- Portable equipment

TP4057 is packaged with SOT23-6

## Typical applications

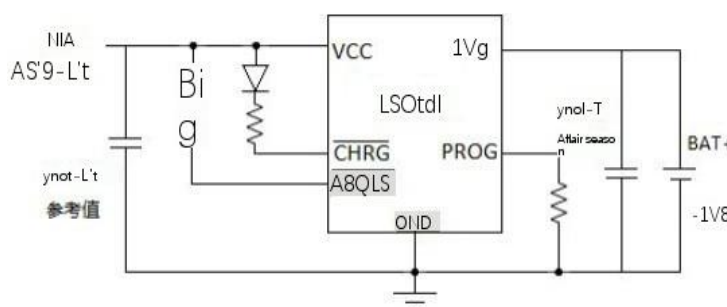

## Distribution of pin

### SOT23-6

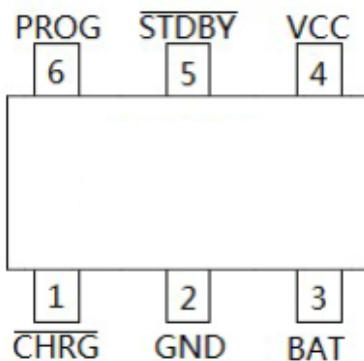

## Pin Description

Pin number	Pin name	describe
1	CHRG	Battery charging indicating terminal
2	GND	The end of the earth
3	BAT	Battery end
4	VCC	Power supply terminal
5	STDBY	Battery charging completion indicator
6	PROG	Programmable constant current charging current setting terminal

**Maximum rating (note)**

Parameter	Range	Company
VCC terminal voltage	-0.3 to 6.5	V
Prog terminal voltage	-0.3 to 6.5	V
Bat terminal voltage	-0.3 to 6.5	V
CHRG terminal voltage	-0.3 to 8	V
Stdby terminal voltage	-0.3 to 8	V
Bat terminal current	500 mA	mA
Prog terminal current	800 uA	uA
Maximum power consumption	400	mW
	800 (increase PCB heat dissipation) <sup>(1)</sup>	
Working environment temperature	-40 ~ 85	°C
Minimum / maximum storage temperature Tstg	-65 to 125	°C

Note (1) : The additon of PCB heat dissipation parameters is for teference only.

**ESD and Latch-up level**

ESD level of mannequin	4000V
ESD level of machine model	400 V
Latch-up level	400mA

Structure diagram

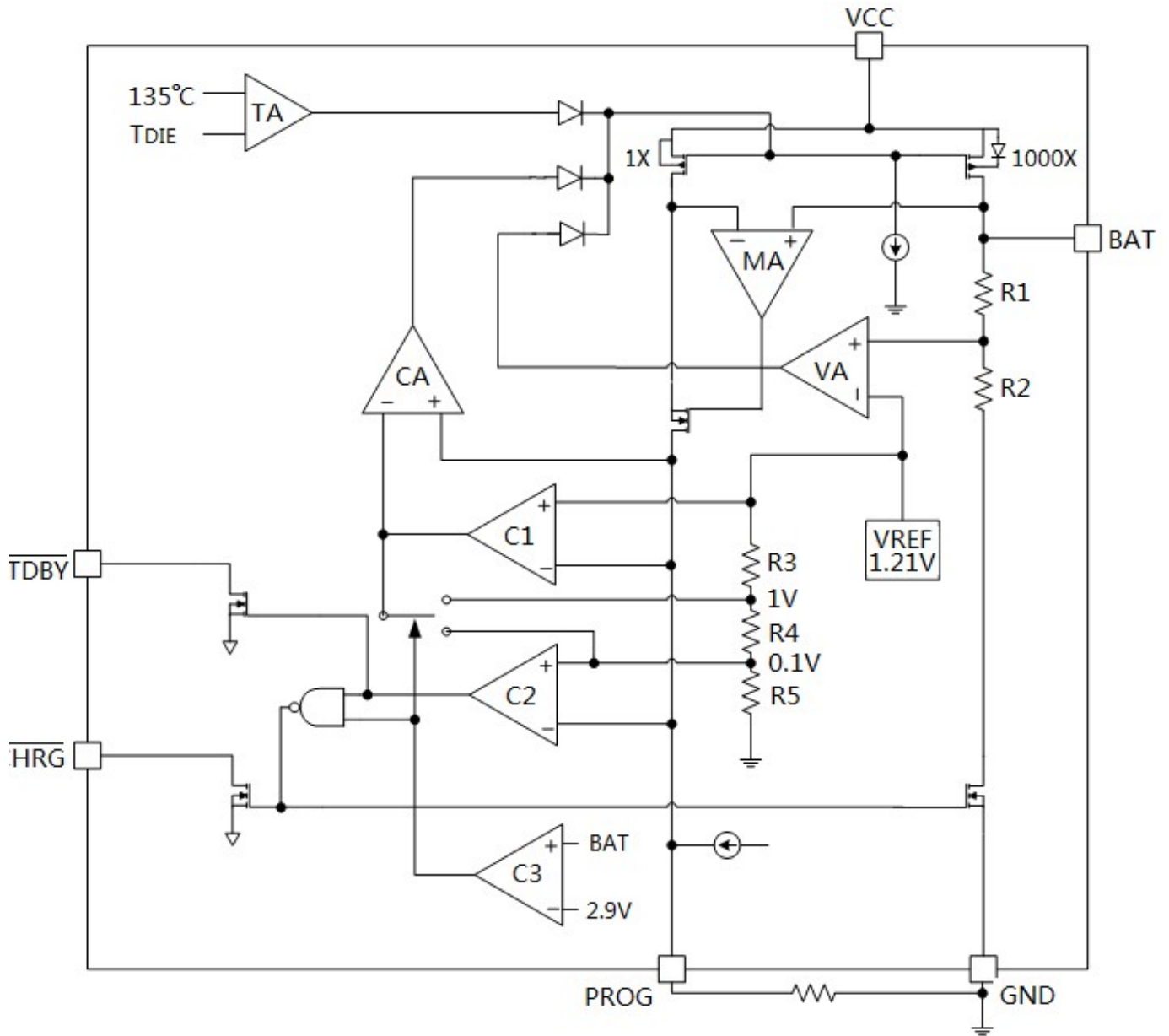

### Electrical characteristics

(if not specified, ambient temperature = 25 °C, input voltage = 5V)

Symbol	parameter	Test conditions	Min	Typical values	Max	Company
VCC	Input power voltage		4.0		6.5	V
ICC	Input power current	Charging mode (rprog = 10K) <sup>(1)</sup>		240	500	uA
		Standby mode (charging termination)		45	90	uA
		Shutdown mode (rprog not connected, VCC < Vbat, VCC < vuvlo)		25	50	uA
VFLOAT	Output floating charge voltage	0°C ≤ T ≤ 85°C, IBAT = 40mA	4.198	4.24	4.282	V
IBAT	Bat charging current	Constant current mode, rprog = 10K	93	100	107	mA
		Constant current mode, rprog = 2K	465	500	535	mA
		Standby mode, Vbat = 4.2V	0	-2.5	-6	uA
		Stop mode		1	2	uA
		Battery reverse mode, Vbat = -4V		0.7		mA
		VCC = 0V, sleep mode		0	1	uA
ITRIKL	trickle charge current	VBAT? VTRIKL, RPROG=2K	40	50	60	mA
VTRIKL	Trickle charging threshold voltage	Vbat up	2.7	2.9	3.1	V
VTRHYS	Trickle charge hysteresis voltage	Vbat decreased	60	80	100	mV
VUVLO	VCC undervoltage locking voltage	VCC rises	3.6	3.8	4.0	V
VUVHYS	VCC undervoltage locking hysteresis voltage	VCC decreased	150	200	300	mV
VMSD	Manual turn off threshold voltage	Vprog up	1.15	1.21	1.30	V
		Vprog decreased	0.9	1.0	1.1	V
VASD	VCC - Vbat locking voltage	VCC rises	70	100	140	mV
		VCC decreased	5	30	50	mV
ITERM	termination current threshold (m222) <sup>(2)</sup>	RPROG = 10K	0.085	0.10	0.115	mA/mA
		RPROG = 2K	0.085	0.10	0.115	mA/mA
VPROG	Prog pin voltage	Constant current mode, rprog = 10K	0.93	1.0	1.07	V
VCHRG	CHRG output low level	I CHRG = 5mA		0.35	0.6	V
VSTDBY	Stdby output low level	I STDBY = 5mA		0.35	0.6	V
ΔVRECHG	Threshold voltage of rechargeable battery	VFLOAT - VRECHG		100	200	mV
tRECHG	Recharging delay time	Vbat from high to low	0.8	1.8	4	ms
tTERM	Charging termination delay time	IBAT drops below ICHG / 10	0.63	1.4	3	ms
I PROG	Pull up current at prog terminal			2.0		uA

Note (1): It is in charging state, ICC = Ivcc - IBAT

(2) Here C / 10 termination current threshold refers to the ratio of termination current to constant current charging current

### Instructions

TP4057 is a linear charger specially designed for lithium-ion batteries. It uses the power MOSFET inside the chip to charge the battery at constant current / constant voltage. The charging current can be determined by external resistance programming, and the maximum charging current can reach 500 mA. TP4057 has two status indication outputs with open drain, CHRG and stbby. The power transistor circuit in the chip automatically reduces the charging current when the junction temperature of the chip exceeds 135°C. This function enables users to make full use of the chip for charging, without worrying about the chip overheating and damaging the chip or external components.

### Working principle

When the input voltage is higher than TP4057, the input voltage can be detected. If the battery voltage is lower than 2.9V, the charger will pre charge the battery with a small current. When the battery voltage exceeds 2.9V, the charger uses constant current mode to charge the battery, and the charging current is determined by the resistance between prog terminal and GND terminal. When the battery voltage is close to 4.2V, the charging current decreases gradually and TP4057 enters constant voltage charging mode. When the charging current decreases to the charging end threshold, the charging cycle ends.

The end of charge threshold is 1 / 10 of the constant current charging current. When the battery voltage drops below the recharging threshold, a new charging cycle will start automatically. The high-precision voltage reference, error amplifier and resistance divider network ensure that the accuracy of bat modulation voltage is less than 1%, which meets the requirements of lithium-ion and lithium polymer batteries. When the input voltage loses power or the input voltage is lower than the battery voltage, the charger enters the shutdown mode, and the current consumed by the battery terminal is less than 2ua, thus increasing the standby time.

### ● Charging termination

When the charging current drops to 1 / 10 of the set value after reaching the final floating charge voltage, the charging cycle is terminated. This condition is detected by using an internal filter comparator to monitor the prog terminal. When the prog terminal voltage drops below 100mV for more than 1.8ms, the charging is terminated and TP4057 enters the standby mode. At this time, the input power supply current drops to about 45ua.

When charging, the transient load on bat terminal will make the voltage of prog terminal drop below 100mV when DC charging current drops to 1 / 10 of the set value. The 1.8ms delay time of comparator ensures that transient load of this nature will not lead to premature termination of charging cycle. Once the average charging current falls below 1 / 10 of the set value, the TP4057 centralized charging cycle stops providing any current through the bat terminal. In this state, all loads on the bat end must be powered by batteries.

### ● Charging status indication

TP4057 has two drain open state indication outputs CHRG and stbby. When the charger is in charging state, CHRG is pulled to low level, and in other states, CHRG is in high resistance state; When the battery charging is finished, the stbby is pulled to the low level. In other states, the stbby is in the high resistance state.

When the battery is not connected to the charger, CHRГ flashes to indicate that no battery is installed.

State of charge	CHRG	STDBY
Charging	bright	Extinguish
Charging complete	Extinguish	bright
Bat end connected with 1uF capacitor, no battery	Flicker (frequency about 20Hz)	bright

## ● Thermal limits

An internal thermal feedback loop will reduce the set charging current if the chip temperature rises above 135 °C. This function prevents the TP4057 from overheating and allows users to increase the upper limit of the power processing capacity of a given circuit board and reduce the risk of damage to the tp4057.

## Under voltage locking

TP4057 has an internal undervoltage locking circuit to monitor the input voltage and keep the chip in shutdown mode before the VCC rises to the under voltage locking threshold voltage. When the VCC voltage increases to 3.8V, the chip exits UVLO and starts to work normally. The UVLO hysteresis voltage is 200mV when the VCC drops.

## Automatic charging cycle

When the battery voltage reaches the floating charge voltage, TP4057 monitors the bat terminal voltage immediately after the charging cycle is terminated. When the bat terminal voltage is lower than 4.1V, the charging cycle starts again. It ensures that the battery is maintained in a state of near full charge, and eliminates the need for periodic charging cycle start-up.

**Package description: SOT23-6**

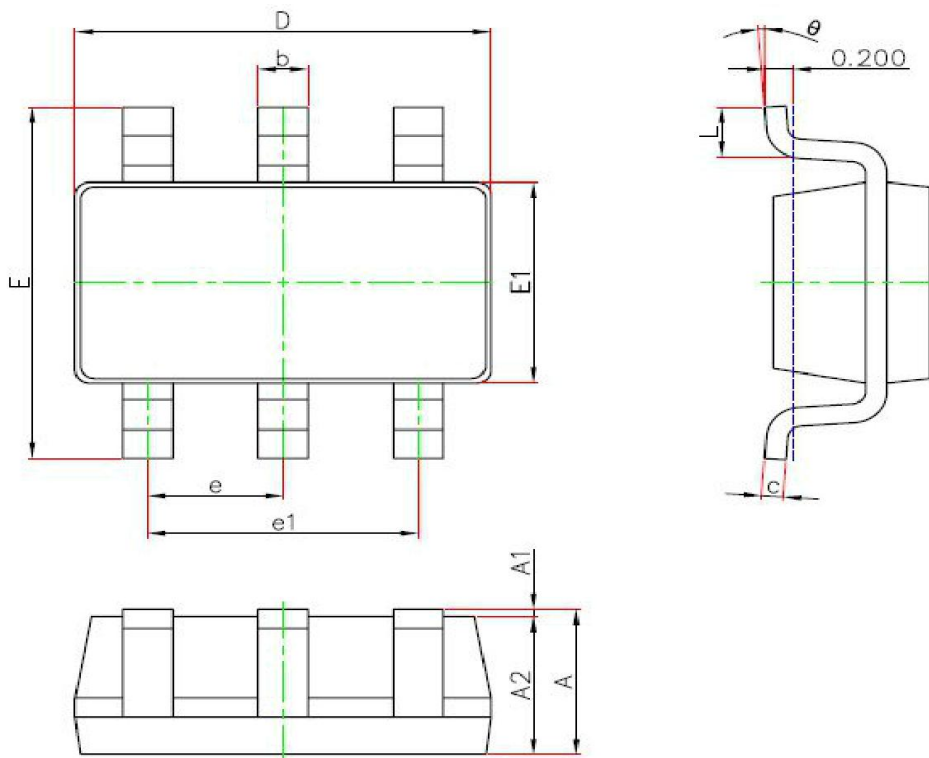



Symbol	Dimensions In Millimeters		Dimensions In Inches	
	Min.	Max.	Min.	Max.
A	1.050	1.250	0.041	0.049
A1	0.000	0.100	0.000	0.004
A2	1.050	1.150	0.041	0.045
b	0.300	0.500	0.012	0.020
c	0.100	0.200	0.004	0.008
D	2.820	3.020	0.111	0.119
E1	1.500	1.700	0.059	0.067
E	2.650	2.950	0.104	0.116
e	0.950(BSC)		0.037(BSC)	
e1	1.800	2.000	0.071	0.079
L	0.300	0.600	0.012	0.024
$\theta$	0°	8°	0°	8°

**Ordering information**







Order code	Package	Baseqty	Delivery mode
UMW TP4057	SOT-23-6	3000	Tape and reel

## Looking for pricing, stock, or lifecycle information?

Click below to explore more details on WIN SOURCE:

-  [View TP4057 on WIN SOURCE](#)
-  [NXP / Nexperia Information](#)

## Optimize Your Supply Chain with WIN SOURCE Solutions

-  Global Sourcing Solution
-  Obsolete Management
-  Cost Control Management
-  Shortage Management
-  Alternative Solution
-  Excess Inventory Management