



**THE DATASHEET OF  
SKY13456-11**



DATA SHEET

# SKY13456-11: 0.6 to 2.7 GHz DP14T Switch with MIPI® RFFE Interface

## Applications

- 2G/3G/4G multimode cellular handsets (LTE, UMTS, CDMA2000, EDGE, GSM)
- Embedded data cards
- Carrier aggregation (low band/high band)

## Features

- Broadband frequency range: 0.6 to 2.7 GHz
- Low insertion loss
- High isolation and linearity
- Integrated GSM harmonic filter
- Integrated, programmable MIPI interface using separate registers for low and high bands
- Twelve TRX ports, one GSM low band transmit port, and one GSM high band transmit port
- Integrated B17 3<sup>rd</sup> harmonic filter on TRx10 port designed for ultra-high linearity
- Small MCM (26-pin, 2.8 x 3.2 mm) package (MSL3, 260 °C per JEDEC J-STD-020)



Skyworks Green™ products are compliant with all applicable legislation and are halogen-free. For additional information, refer to *Skyworks Definition of Green™*, document number SQ04-0074.

## Description

The SKY13456-11 is a double-pole, fourteen-throw (DP14T) antenna switch. The device maintains low insertion loss and high isolation for both transmit and receive switching paths. The high linearity performance and low insertion loss makes the SKY13456-11 an ideal choice for carrier aggregation applications.

The device contains two single-pole, seven-throw (SP7T) switches that can accommodate UMTS, CDMA2000, EDGE, GSM, and LTE applications. Switching is controlled by the MIPI decoder. There is an external MIPI select pin that enables how the switch responds to power mode triggers. When this pin is grounded, the switch responds to any of the power mode triggers. When this pin

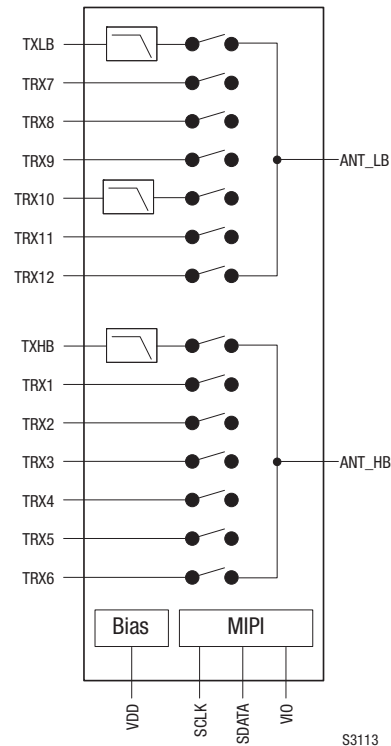

Figure 1. SKY13456-11 Block Diagram

is left open, the switch responds to individual power mode triggers.

The high-band and low-band SP7T switch bank can be independently controlled with two separate registers. Register 0 controls the high bands (pin signals TRX1 to TRX6) and Register 1 controls the low bands (pin signals TRX7 to TRX12). No external DC blocking capacitors are required on the RF path as long as no DC voltage is applied. There is an integrated B17 3<sup>rd</sup> harmonic filter on the TRx10 port.

The switch also provides an excellent triple beat ratio and second/third order intermodulation distortion (IMD2/IMD3) performance. The SKY13456-11 is manufactured in a small, 2.8 x 3.2 mm, 26-pin Multi-Chip Module (MCM) package.

A functional block diagram is shown in Figure 1. The pin configuration and package are shown in Figure 2. Signal pin assignments and functional pin descriptions are provided in Table 1.

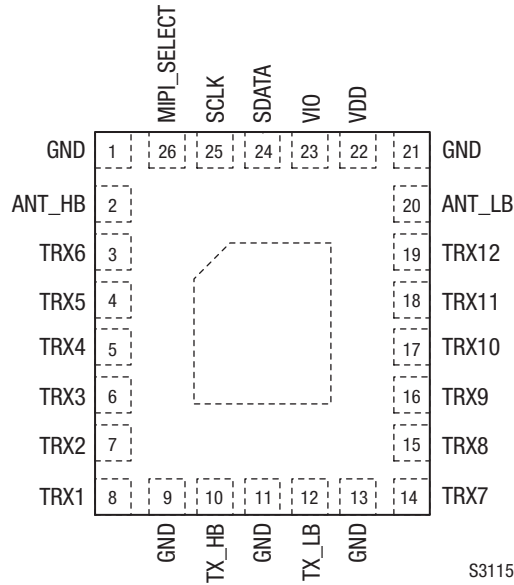

**Figure 2. SKY13456-11 Pinout (Top View)**

**Table 1. SKY13456-11 Signal Descriptions<sup>1</sup>**

Pin	Name	Description	Pin	Name	Description
1	GND	Ground	14	TRX7	RF input/output port 7
2	ANT_HB	High band antenna RF port	15	TRX8	RF input/output port 8
3	TRX6	RF input/output port 6	16	TRX9	RF input/output port 9
4	TRX5	RF input/output port 5	17	TRX10	RF input/output port 10. Designed for Band 17 transmit.
5	TRX4	RF input/output port 4	18	TRX11	RF input/output port 11
6	TRX3	RF input/output port 3	19	TRX12	RF input/output port 12
7	TRX2	RF input/output port 2	20	ANT_LB	Low band antenna RF port
8	TRX1	RF input/output port 1	21	GND	Ground
9	GND	Ground	22	VDD	DC power supply
10	TX_HB	GSM high band transmit RF input port with integrated harmonic filter	23	VIO	Interface supply voltage
11	GND	Ground	24	SDATA	Data
12	TX_LB	GSM low band transmit RF input port with integrated harmonic filter	25	SCLK	Clock
13	GND	Ground	26	MIPI_SELECT	MIPI interface select. When this pin is grounded, the switch responds to any of the power mode triggers. When this pin is left open, the switch is RFFE MIPI compliant and responds to individual power mode triggers.

<sup>1</sup> Bottom ground paddles must be connected to ground.

## Electrical and Mechanical Specifications

The absolute maximum ratings of the SKY13456-11 are provided in Table 2. Electrical specifications are provided in Table 3.

IMD2 and IMD3 test conditions for various frequencies are listed in Tables 4, 5, and 6. Triple beat ratio (TBR) frequencies and power levels are noted in Table 7.

Figure 3 illustrates the typical test setup used to measure intermodulation products. This industry standardized test is used to simulate the WCDMA Band 1 linearity of the antenna switch. A +20 dBm continuous wave (CW) signal,  $f_{\text{FUND}}$ , is sequentially applied to the TRX1 through TRX12 ports, while a -15 dBm CW blocker signal,  $f_{\text{BLK}}$ , is applied to the ANT\_LB port.

The resulting third order intermodulation distortion (IMD3),  $f_{\text{RX}}$ , is measured over all phases of  $f_{\text{FUND}}$ . The SKY13456-11 exhibits exceptional performance for all TRXx ports.

Table 8 shows the isolation matrix for "Ant" to "Off" arms for the Low Band. Table 9 shows the isolation matrix for "On" arms to "Off" arms for the Low Band. Table 10 shows the isolation matrix for "Ant" to "Off" arms for the High Band. Table 11 shows the isolation matrix for "On" Arms to "Off" arms for the High Band.

Table 12 describes the register content and programming read/write sequences. Refer to the *MIPI Alliance Specification for RF Front-End Control Interface (RFFE)*, v1.10 (26 July 2011) for additional information on MIPI programming sequences and MIPI bus specifications.

Figures 4 and 5 provide the timing diagrams for register write commands and read commands, respectively.

Table 13 provides the Register 0 logic and Table 14 provides the logic for Register 1. Table 15 describes the register parameters and bit values.

**Table 2. SKY13456-11 Absolute Maximum Ratings<sup>1</sup>**

Parameter	Symbol	Minimum	Maximum	Units
Power supply	V <sub>DD</sub>	2.5	5.0	V
Digital control signal	V <sub>IO</sub>		2	V
RF input power:	P <sub>IN</sub>			
TX_LB pin			+36	dBm
TX_HB pin			+34	dBm
All TRXx pins			+31	dBm
Storage temperature	T <sub>STG</sub>	-55	+150	°C
Operating temperature	T <sub>OP</sub>	-30	+90	°C

<sup>1</sup> Exposure to maximum rating conditions for extended periods may reduce device reliability. There is no damage to device with only one parameter set at the limit and all other parameters set at or below their nominal value. Exceeding any of the limits listed here may result in permanent damage to the device.

---

**ESD HANDLING:** *Although this device is designed to be as robust as possible, electrostatic discharge (ESD) can damage this device. This device must be protected at all times from ESD when handling or transporting. Static charges may easily produce potentials of several kilovolts on the human body or equipment, which can discharge without detection. Industry-standard ESD handling precautions should be used at all times.*

---

**Table 3. SKY13456-11 Electrical Specifications<sup>1</sup> (1 of 2)**  
**(V<sub>DD</sub> = 2.85 V, T<sub>OP</sub> = +25 °C, Characteristic Impedance [Z<sub>0</sub>] = 50 Ω, Unless Otherwise Noted)**

Parameter	Symbol	Test Condition	Min	Typ	Max	Units
<b>RF Specifications</b>						
Operating frequency	f		0.6		2.7	GHz
Insertion loss	IL	TXLB to ANT_LB, 824 to 915 MHz		1.25	1.50	dB
		TRX7, 8, 9, 11, 12 to ANT_LB, 600 to 960 MHz		0.50	0.80	dB
		TRX10 to ANT_LB, 704 to 716 MHz (band 17 transmit)		0.85	0.95	dB
		TXHB to ANT_HB, 1710 to 1910 MHz		1.25	1.5	dB
		TRX1/6 to ANT_HB, 1710 to 1990 MHz		0.55	0.8	dB
		TRX1/6 to ANT_HB, up to 2690 MHz		0.75	1.0	dB
GSM harmonic attenuation	H2LB	Transmit low band to ANT_LB, 2fo 1648 to 1830 MHz	23	28		dB
	H3LB	Transmit low band to ANT_LB, 3fo 2472 to 2745 MHz	23	28		dB
	past 3fo	Transmit low band to ANT_LB, past 3fo to 12.75 GHz		17		dB
	H2HB	Transmit high band to ANT_HB, 2fo 3420 to 3820 MHz	23	28		dB
	H3HB	Transmit high band to ANT_HB, 3fo 5130 to 5730 MHz	23	28		dB
	H past 3fo	Transmit high band to ANT_HB, past 3fo to 12.75 GHz		17		dB
Isolation: TRx to any “off” TRx port (non-adjacent ports)	Iso	Up to 960 MHz	32	35		dB
		Up to 2170 MHz	27	30		dB
		Up to 2690 MHz	23	26		dB
Isolation: TRx to any “off” TRx port (adjacent ports)	Iso	Up to 960 MHz	27	30		dB
		Up to 2170 MHz	22	25		dB
		Up to 2690 MHz	17	22		dB
Isolation: TXLB to TRX7/12	Iso	824 to 915 MHz	31	36		dB
Isolation: TXHB to TRX1/6	Iso	1710 to 1910 MHz	31	29		dB
Isolation: opposite side TRx ports (TRX1/6 to TRX7/12)	Iso	Up to 2690 MHz	28	37		dB
Isolation: ANT_LB to ANT_HB port	Iso	Up to 2690 MHz		25		dB
“On” state match	VSWR	Up to 2.7 GHz			1.5:1	-

**Table 3. SKY13456-11 Electrical Specifications<sup>1</sup> (2 of 2)**  
**(V<sub>DD</sub> = 2.85 V, T<sub>OP</sub> = +25 °C, Characteristic Impedance [Z<sub>0</sub>] = 50 Ω, Unless Otherwise Noted)**

Parameter	Symbol	Test Condition	Min	Typ	Max	Units
<b>RF Specifications (continued)</b>						
Low band GSM harmonics	2fo, 3fo	PIN = +35 dBm, 50 Ω		-55	-45	dBm
		PIN = +35 dBm, 5:1 VSWR		-43	-36	dBm
High band GSM harmonics	2fo, 3fo	PIN = +33 dBm, 50 Ω		-55	-45	dBm
		PIN = +33 dBm, 5:1 VSWR		-47	-40	dBm
Band 13 harmonics with no external filter	2fo	TRX7/12 ports to ANT_LB port @ 786.5 MHz, PIN <+25 dBm, VSWR = 1:1		-78		dBm
Low band TRx harmonics	2fo, 3fo	TRX7/12 ports to ANT_LB port, PIN =+26 dBm		-62	-55	dBm
High band TRx harmonics	2fo, 3fo	TRX1/6 ports to ANT_LB port, PIN =+26 dBm		-62	-55	dBm
Band 17 harmonics	3fo	TRX10 port to ANT_LB port @ 710 MHz, PIN = +25 dBm, VSWR = 2:1, all phases		-92		dBm
Second order input intercept point	IIP2	AWS, PCS, IMT, CDMA2000 modes (see Table 4)	+95.5			dBm
		Cellular (see Table 4)	+113.5			dBm
		UMTS mode (see Table 6)	+102.0			dBm
Third order input intercept point	IIP3	UMTS mode (see Table 5)	+61			dBm
Triple beat ratio	TBR	See Table 7	+81	+87		dBc
Turn-on time	ton	From application of V <sub>DD</sub> and V <sub>IO</sub>			20	μs
Wake-up time	tw	From isolation state		2	5	μs
Switching speed	ts	Port-to-port, 50% V <sub>CTL</sub> to final RF power ±1 dB		2	5	μs
<b>DC Specifications</b>						
Supply voltage	V <sub>DD</sub>		2.50	2.85	3.30	V
Supply current: GSM850/EGSM900/DCS1800/ PCS1900 transmit WCDMA/CDMA2000 transmit/receive	I <sub>DD</sub>			50	100	μA
				50	100	μA
Digital data and clock signals: High Low Current	SDATA, SCLK		0.8 × V <sub>IO</sub> 0		V <sub>IO</sub> 0.2 × V <sub>IO</sub> 5	V V μA
Interface supply voltage level	V <sub>IO</sub>		1.65	1.80	1.95	V
Supply ripple					20	mVp-p

<sup>1</sup> Performance is guaranteed only under the conditions listed in this table.

**Table 4. CDMA2000 IIP2 Test Conditions**

Band	Temperature (°C)	In-Band (MHz)	CW Tone 1 (MHz)	CW Tone 1 (dBm)	CW Tone 2 (MHz)	CW Tone 2 (dBm)
Cellular	25	869.28	824.28	+26	1693.56	-20
	0, 25, 90	881.61	836.61	+26	1718.22	-20
	25	893.31	848.31	+26	1741.62	-20
PCS	25	1930.05	1850.05	+26	3780.10	-20
	0, 25, 90	1965.00	1885.00	+26	3850.00	-20
	25	1989.95	1909.95	+26	3899.90	-20
AWS	25	2110.00	1710.00	+26	3820.00	-20
	0, 25, 90	2132.50	1732.50	+26	3865.00	-20
	25	2155.00	1755.00	+26	3910.00	-20

**Table 5. IIP3 Test Conditions (UMTS Linearity)<sup>1</sup>**

Band	CW Tone 1 (MHz)	CW Tone 1 (dBm)	CW Tone 2 (MHz)	CW Tone 2 (dBm)
2600 MHz	2535	+20	2415	-15
IMT	1950	+20	1760	-15
PCS	1880	+20	1800	-15
DCS	1745	+20	1650	-15
PDC	1440	+20	1392	-15
900 MHz	892	+20	847	-15
US cellular	835	+20	790	-15

<sup>1</sup> Power levels are referenced to the antenna port and may be increased to facilitate measurement.

**Table 6. IIP2 Test Conditions (UMTS Linearity)**

Band	CW Tone 1 (MHz)	CW Tone 1 (dBm)	CW Tone 2 (MHz)	CW Tone 2 (dBm)
2600 MHz	2535	+20	120	-15
IMT	1950	+20	190	-15
PCS	1880	+20	80	-15
DCS	1745	+20	95	-15
PDC	1440	+20	48	-15
900 MHz	892	+20	45	-15
US cellular	835	+20	45	-15

<sup>1</sup> Power levels are referenced to the antenna port and may be increased to facilitate measurement.

**Table 7. Triple Beat Ratio Frequencies and Power Levels**

Band	Transmit Frequency 1 (MHz)	Transmit Power 1 (dBm)	Transmit Frequency 2 (MHz)	Transmit Power 2 (dBm)	Frequency Blocker ANT (MHz)	Power Blocker (dBm)	Triple Beat Product Frequency (MHz)
2	1880.0	+21.5	1881.0	+21.5	1960.0	-30	1960.0 ± 1
5	836.5	+21.5	837.5	+21.5	881.5	-30	881.5 ± 1

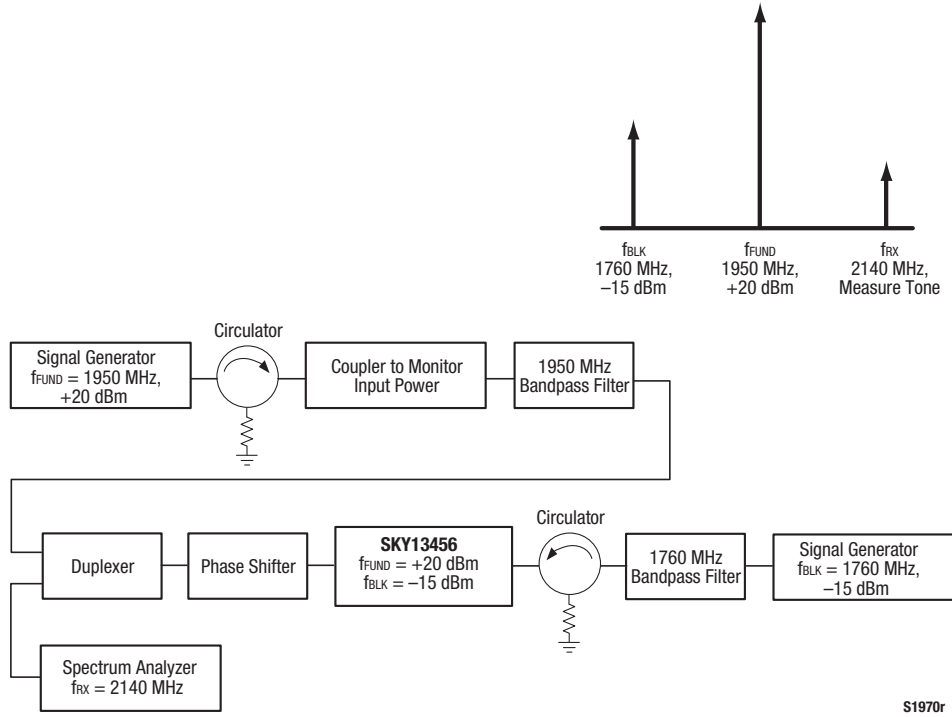

Figure 3. Typical Third Order Intermodulation Test Setup

Table 8. SKY13456-11 Isolation Matrix “ON” Arms to “OFF” Arms

ON_Throw	Freq (GHz)	Isolation (dB)						
		TRx12	TRx11	TRx10	TRx9	TRx8	TRx7	TxLB
TxLB	0.915	-36	-43	-34	-40	-38	-36	
TRx7	0.915	-37	-44	-36	-37	-24		-31
TRx8	0.915	-37	-43	-33	-32		-27	-32
TRx9	0.915	-38	-38	-26		-28	-36	-32
TRx10	0.915	-35	-26		-26	-36	-41	-24
TRx11	0.915	-29		-25	-37	-40	-45	-32
TRx12	0.915		-29	-32	-41	-40	-44	-32

Table 9. SKY13456-11 Isolation Matrix “ANT” to “OFF” Arms

ON_Throw	Freq (GHz)	Isolation (dB)						
		TRx12	TRx11	TRx10	TRx9	TRx8	TRx7	TxLB
TxLB	0.915	-28	-37	-31	-35	-36	-39	
TRx7	0.915	-28	-40	-44	-35	-37		-31
TRx8	0.915	-28	-41	-49	-37		-37	-31
TRx9	0.915	-28	-41	-37		-36	-36	-32
TRx10	0.915	-25	-36		-35	-40	-41	-24
TRx11	0.915	-27		-43	-44	-41	-43	-32
TRx12	0.915		-39	-34	-44	-41	-44	-32

**Table 10. SKY13456-11 Isolation Matrix “ON” Arms to “OFF” Arms**

ON_Throw	Freq (GHz)	Isolation (dB)						
		TRx6	TRx5	TRx4	TRx3	TRx2	TRx1	TxHB
TRx1	1.910	-30	-37	-38	-27	-19		-32
TRx1	2.170	-28	-35	-36	-26	-18		-34
TRx1	2.700	-26	-32	-34	-24	-16		-39
TRx2	1.910	-30	-35	-35	-22		-20	-39
TRx2	2.170	-29	-33	-34	-21		-18	-38
TRx2	2.700	-26	-30	-32	-20		-17	-36
TRx3	1.910	-30	-31	-26		-25	-32	-39
TRx3	2.170	-29	-29	-25		-23	-30	-40
TRx3	2.700	-26	-27	-23		-21	-28	-43
TRx4	1.910	-30	-20		-25	-34	-37	-39
TRx4	2.170	-29	-19		-24	-33	-36	-40
TRx4	2.700	-25	-17		-23	-31	-33	-45
TRx5	1.910	-25		-21	-33	-37	-38	-37
TRx5	2.170	-23		-20	-31	-36	-37	-38
TRx5	2.700	-20		-8	-30	-33	-34	-41
TRx6	1.910		-24	-29	-37	-38	-38	-36
TRx6	2.170		-23	-27	-35	-37	-37	-36
TRx6	2.700		-20	-25	-33	-34	-33	-39
TxHB	1.910	-29	-38	-39	-40	-35	-30	
TxHB	2.170	-28	-37	-38	-40	-35	-31	
TxHB	2.700	-29	-38	-39	-47	-35	-32	

**Table 11. SKY13456-11 Isoaltion Matrix “ANT” Arms to “OFF” Arms**

ON_Throw	Freq (GHz)	Isolation (dB)						
		TRx6	TRx5	TRx4	TRx3	TRx2	TRx1	TxHB
TRx1	1.910	-23	-35	-33	-36	-27		-31
TRx1	2.170	-22	-34	-32	-35	-25		-29
TRx1	2.700	-21	-32	-29	-32	-22		-28
TRx2	1.910	-23	-36	-33	-32		-28	-28
TRx2	2.170	-22	-34	-31	-31		-27	-28
TRx2	2.700	-21	-33	-28	-28		-24	-28
TRx3	1.910	-23	-37	-34		-31	-28	-30
TRx3	2.170	-22	-35	-33		-30	-26	-30
TRx3	2.700	-20	-33	-30		-27	-24	-31
TRx4	1.910	-21	-31		-35	-39	-38	-34
TRx4	2.170	-20	-29		-34	-38	-36	-34
TRx4	2.700	-18	-26		-31	-35	-33	-36
TRx5	1.910	-23		-31	-36	-39	-38	-34
TRx5	2.170	-21		-30	-34	-37	-36	-34
TRx5	2.700	-19		-27	-31	-35	-33	-37
TRx6	1.910		-32	-32	-8	-39	-38	-35
TRx6	2.170		-31	-31	-37	-37	-36	-34
TRx6	2.700		-28	-28	-34	-34	-33	-37
TxHB	1.910	-23	-33	-33	-38	-36	-37	
TxHB	2.170	-21	-31	-31	-36	-34	-35	
TxHB	2.700	-18	-28	-28	-34	-34	-32	

**Table 12. Command Sequence Bit Definitions**

Type	SSC	C11-C8	C7	C6-C5	C4	C3-C0	Parity Bits	BPC	Extended Operation					
									DA7(1)-DA0(1)	Parity Bits	BPC	DA7(n)-DA0(n)	Parity Bits	BPC
Reg 0 Write	Y	SA[3:0]	1	Data[6:5]	Data[4]	Data[3:0]	Y	Y	-	-	-	-	-	-
Reg Write	Y	SA[3:0]	0	10	Addr[4]	Addr[3:0]	Y	-	Data[7:0]	-	-	-	Y	Y
Reg Read	Y	SA[3:0]	0	11	Addr[4]	Addr[3:0]	Y	Y	Data[7:0]	-	-	-	Y	Y

**Legend:**

SSC = Sequence start command      DA = Data/address frame bits      BC = Byte count (# of consecutive addresses)  
 C = Command frame bits      BPC = Bus park cycle

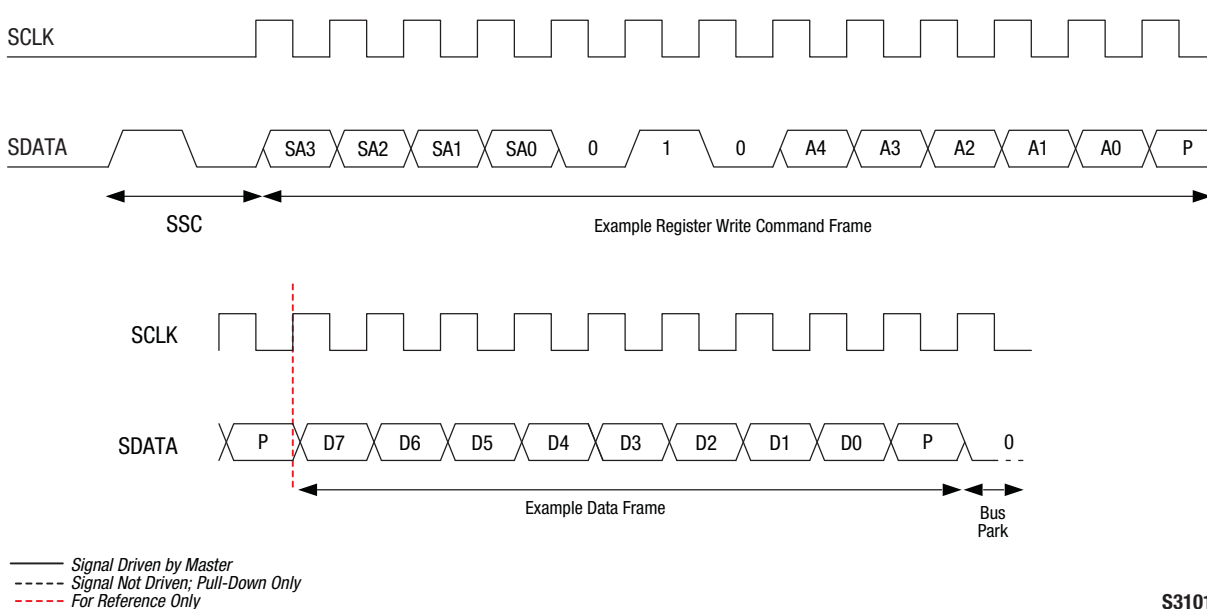

S3101

Figure 4. Register Write Command Timing Diagram

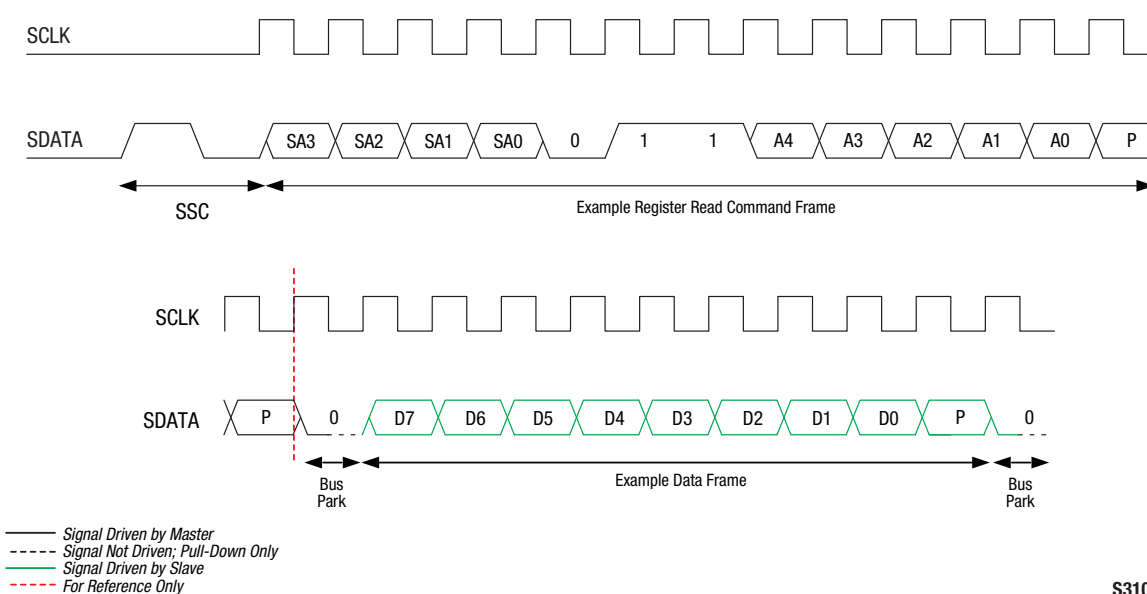

S3102

Figure 5. Register Read Command Timing Diagram

**Table 13. Register 0 Truth Table**

State	Mode	Register Bits							
		D7	D6	D5	D4	D3	D2	D1	D0
1	Isolation (default)	N/U	N/U	N/U	N/U	N/U	0	0	0
2	ANT_HB to TRX1	N/U	N/U	N/U	N/U	N/U	0	0	1
3	ANT_HB to TRX2	N/U	N/U	N/U	N/U	N/U	0	1	0
4	ANT_HB to TRX3	N/U	N/U	N/U	N/U	N/U	0	1	1
5	ANT_HB to TRX4	N/U	N/U	N/U	N/U	N/U	1	0	0
6	ANT_HB to TRX5	N/U	N/U	N/U	N/U	N/U	1	0	1
7	ANT_HB to TRX6	N/U	N/U	N/U	N/U	N/U	1	1	0
8	ANT_HB to TXHB	N/U	N/U	N/U	N/U	N/U	1	1	1

Note: N/U = Not used

**Table 14. Register 1 Truth Table**

State	Mode	Register Bits							
		D7	D6	D5	D4	D3	D2	D1	D0
1	Isolation (default)	N/U	N/U	N/U	N/U	N/U	0	0	0
2	ANT_LB to TRX7	N/U	N/U	N/U	N/U	N/U	0	0	1
3	ANT_LB to TRX8	N/U	N/U	N/U	N/U	N/U	0	1	0
4	ANT_LB to TRX9	N/U	N/U	N/U	N/U	N/U	0	1	1
5	ANT_LB to TRX10	N/U	N/U	N/U	N/U	N/U	1	0	0
6	ANT_LB to TXLB	N/U	N/U	N/U	N/U	N/U	1	0	1
7	ANT_LB to TRX11	N/U	N/U	N/U	N/U	N/U	1	1	0
8	ANT_LB to TRX12	N/U	N/U	N/U	N/U	N/U	1	1	1

Note: N/U = Not used

**Table 15. Register Description and Programming<sup>1</sup> (1 of 2)**

Register		Parameter	Description	Default (Binary)
Name	Address (Hex)			
Register 0	00000	MODE_CTRL	Bits[7:0]: Switch control. See Table 9 for Register 0 logic	-
Register 1	00001	MODE_CTRL	Bits[7:0]: Switch control. See Table 10 for Register 1 logic	-
RFFE_STATUS	001A	SOFTWARE RESET	Bit[7]: Resets all data to default values except for USID, GSID, or the contents of the PM_TRIG Register. 0 = Normal operation 1 = Software reset	0
		COMMAND_FRAME_PARITY_ERR	Bit[6]: Command sequence received with parity error - discard command.	0
		COMMAND_LENGTH_ERR	Bit[5]: Command length error.	0
		ADDRESS_FRAME_PARITY_ERR	Bit[4]: Address frame parity error = 1.	0
		DATA_FRAME_PARITY_ERR	Bit[3]: Data frame with parity error.	0
		READ_UNUSED_REG	Bit[2]: Read command to an invalid address.	0
		WRITE_UNUSED_REG	Bit[1]: Write command to an invalid address.	0
		BID_GID_ERR	Bit[0]: Read command with a BROADCAST_ID (refer to the <i>MIPI Alliance Specification</i> ) or GSID.	0
GROUP_SID	001B	Reserved	Bits[7:4]: Reserved	0000
		GSID	Bits[3:0]: Group slave ID	0000

**Table 15. Register Description and Programming (2 of 2)**

Register		Parameter	Description	Default (Binary)
Name	Address (Hex)			
PM_TRIG (Note 1)	001C	PWR_MODE	Bits[7:6]: 00 = Normal operation (active) 01 = Default settings (startup) 10 = Low power (low power) 11 = Reserved	00
		Trigger_Mask_2	Bit[5]: If this bit is set, trigger 2 is disabled. When all triggers are disabled, if writing to a register that is associated with trigger 2, the data goes directly to the destination register.	0
		Trigger_Mask_1	Bit[4]: If this bit is set, trigger 1 is disabled. When all triggers are disabled, if writing to a register that is associated with trigger 1, the data goes directly to the destination register.	0
		Trigger_Mask_0	Bit[3]: If this bit is set, trigger 0 is disabled. When all triggers are disabled, if writing to a register that is associated with trigger 0, the data goes directly to the destination register.	0
		Trigger_2	Bit[2]: If this bit is set, data is loaded into the trigger 2 registers.	0
		Trigger_1	Bit[1]: If this bit is set, data is loaded into the trigger 1 registers.	0
		Trigger_0	Bit[0]: If this bit is set, data is loaded into the trigger 0 registers.	0
PRODUCT_ID	001D	PRODUCT_ID	Bits[7:0]: This is a read-only register. However, during the programming of the Unique Slave Identifier (USID), a write command sequence is performed on this register but the value is not changed.	01000100
MANUFACTURER_ID	001E	MANUFACTURER_ID	Bits[7:0]: Read-only register	10100101
MAN_USID	001F	Reserved	Bits[7:6]: Reserved	00
		MANUFACTURER_ID	Bits[5:4]: Read-only register	01
		USID	Bits[3:0]: Programmable USID. A write to these bits programs the USID.	1011

<sup>1</sup> Unlike the complete independence between triggers 0, 1, and 2, and also between the associated trigger masks 0, 1, and 2, respectively, as described in the MIPI RFFE Specification, this device uses additional interactions between the provided trigger functions.

The delayed application of updated data to all triggerable registers in this device may be accomplished using any of the three triggers (0, 1, or 2), provided that the particular trigger used is not currently masked off. If multiple triggers are enabled, any or all of those are sufficient to cause the data to be transferred from shadow registers to destination registers for all triggerable registers in the device.

It is also necessary to disable all three triggers (i.e., set all three trigger masks) to ensure that data written to any triggerable register will immediately be written to the destination register at the conclusion of the RFFE command sequence where the data is written.

### Evaluation Board Description

The SKY13456-11 Evaluation Board is used to test the performance of the SKY13456-11 DP14T Switch. An Evaluation Board schematic diagram is provided in Figure 6.

A recommended ESD protection circuit diagram is provided in Figure 7. An assembly drawing for the Evaluation Board is shown in Figure 8.

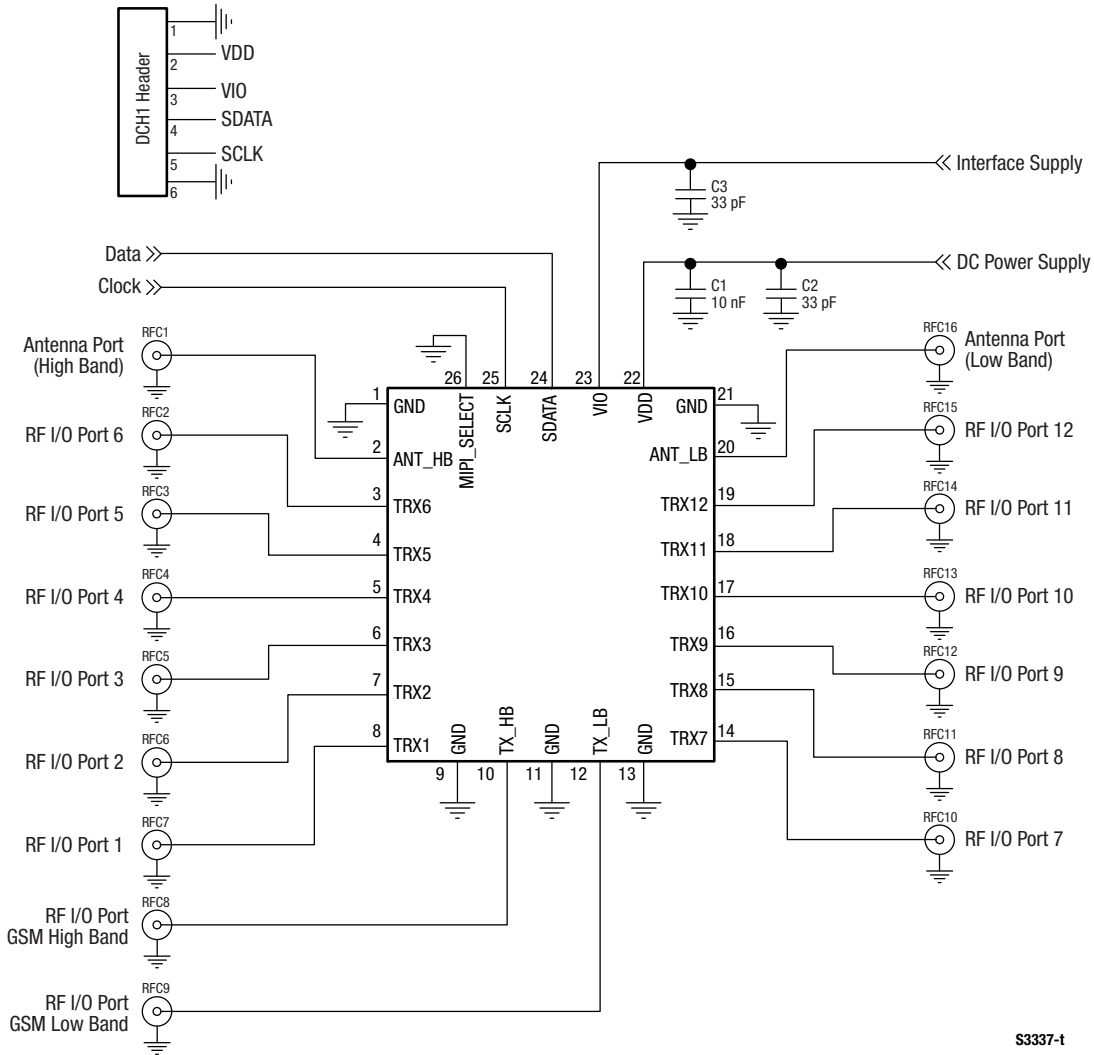

**Figure 6. SKY13456-11 Evaluation Board Schematic**

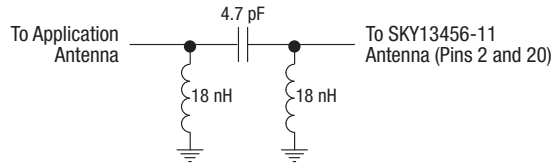

ESD Circuit 1

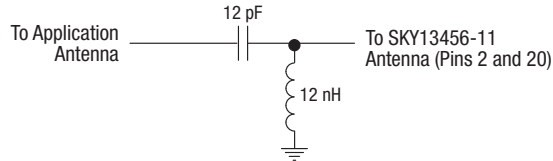

ESD Circuit 2

S2520m

Figure 7. SKY13456-11 Recommended ESD Protection Circuits

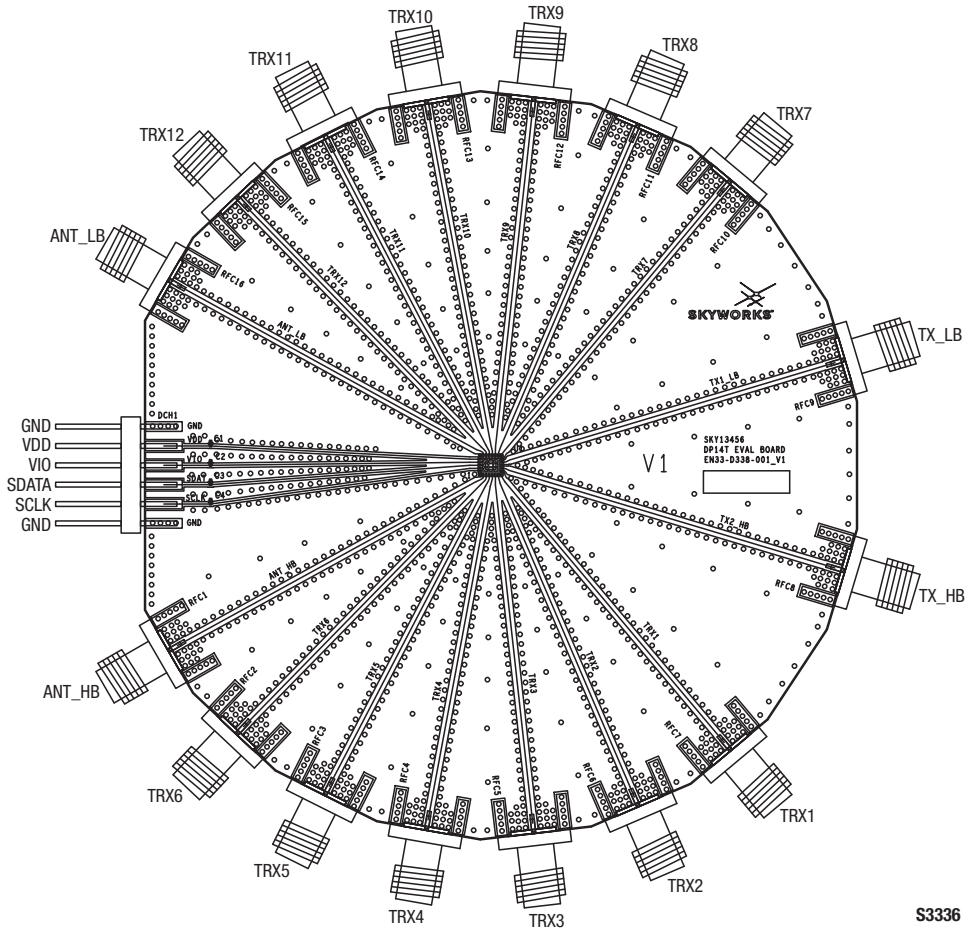

S3336

Figure 8. SKY13456-11 Evaluation Board Assembly Diagram

## Package Dimensions

The PCB layout footprint for the SKY13456-11 is provided in Figure 9. Typical part markings are shown in Figure 10. Package dimensions are shown in Figure 11, and tape and reel dimensions are provided in Figure 12.

## Package and Handling Information

Since the device package is sensitive to moisture absorption, it is baked and vacuum packed before shipping. Instructions on the shipping container label regarding exposure to moisture after the container seal is broken must be followed. Otherwise, problems related to moisture absorption may occur when the part is subjected to high temperature during solder assembly.

The SKY13456-11 is rated to Moisture Sensitivity Level 3 (MSL3) at 260 °C. It can be used for lead or lead-free soldering. For additional information, refer to the Skyworks Application Note, *PCB Design and SMT Assembly/Rework Guidelines for MCM-L Packages*, document number 101752.

Care must be taken when attaching this product, whether it is done manually or in a production solder reflow environment. Production quantities of this product are shipped in a standard tape and reel format.

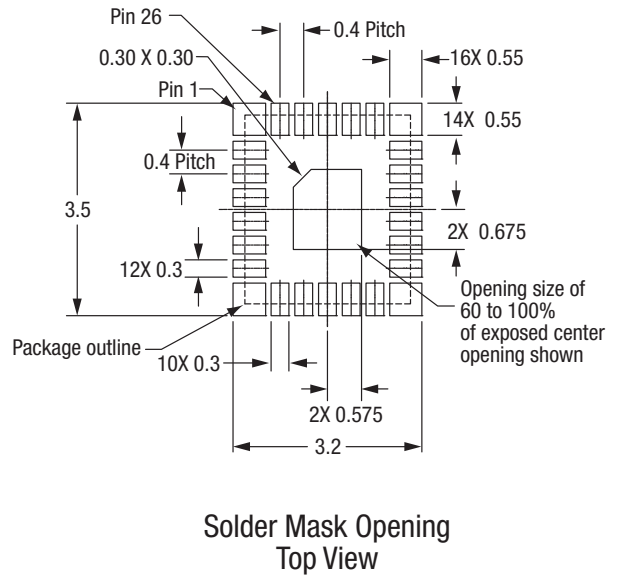
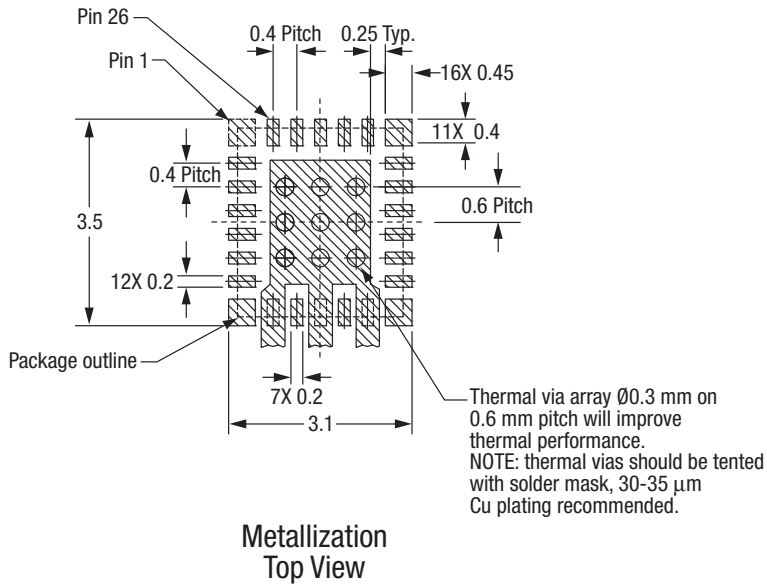
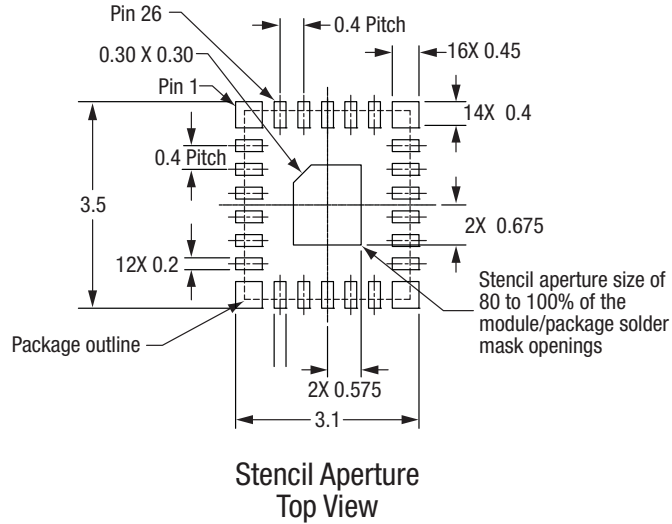

All dimensions are in millimeters

S3116

Figure 9. SKY13456-11 PCB Layout Footprint (Top View)

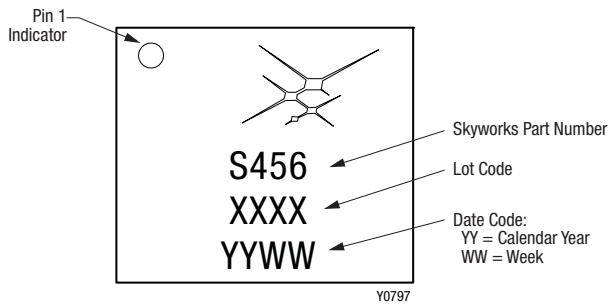

**Figure 10. Typical Part Markings (Top View)**

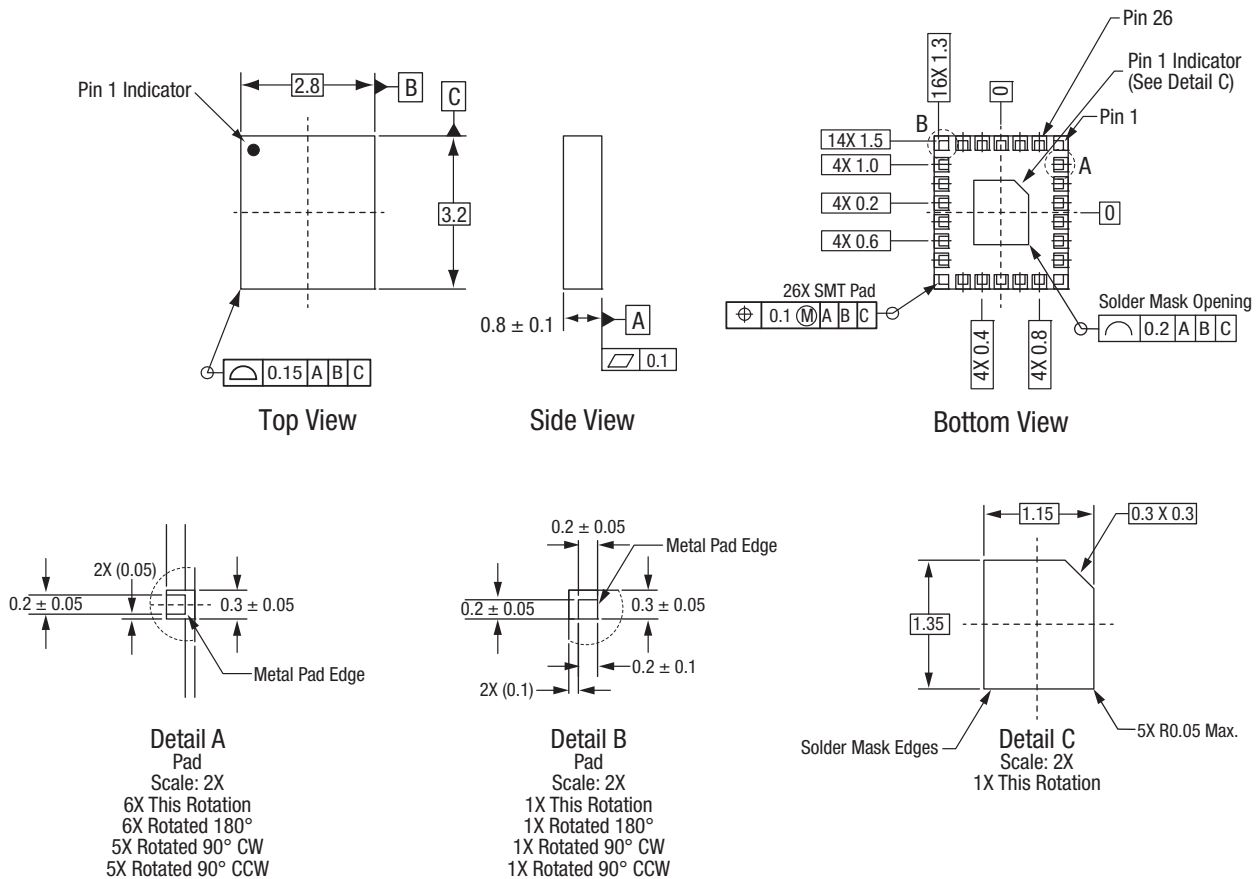

All measurements are in millimeters

Dimensioning and tolerancing according to ASME Y14.5M-1994

S3114

**Figure 11. SKY13456-11 Package Dimensions**

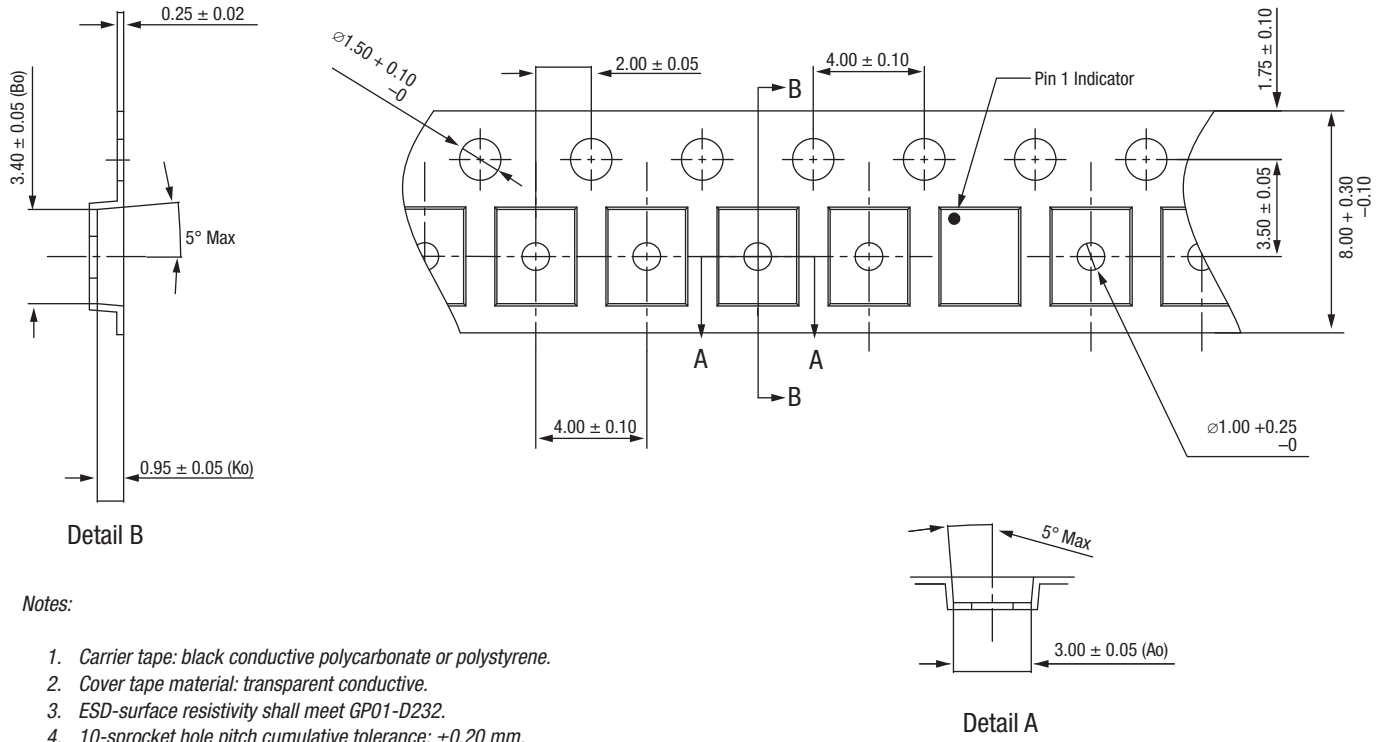

Notes:

1. Carrier tape: black conductive polycarbonate or polystyrene.
2. Cover tape material: transparent conductive.
3. ESD-surface resistivity shall meet GP01-D232.
4. 10-sprocket hole pitch cumulative tolerance: ±0.20 mm.
5. Ao and Bo measurement point to be 0.30 mm from bottom pocket.
6. All dimensions are in millimeters.

Figure 12. SKY13456-11 Tape and Reel Dimensions

Y0799

## Ordering Information

Product Description	Product Part Number	Evaluation Board Part Number
SKY13456-11: 0.6 to 2.7 GHz DP14T Switch with MIPI RFFE Interface	SKY13456-11	SKY13456-11-EVB

Copyright © 2012-2014, 2017 Skyworks Solutions, Inc. All Rights Reserved.

Information in this document is provided in connection with Skyworks Solutions, Inc. (“Skyworks”) products or services. These materials, including the information contained herein, are provided by Skyworks as a service to its customers and may be used for informational purposes only by the customer. Skyworks assumes no responsibility for errors or omissions in these materials or the information contained herein. Skyworks may change its documentation, products, services, specifications or product descriptions at any time, without notice. Skyworks makes no commitment to update the materials or information and shall have no responsibility whatsoever for conflicts, incompatibilities, or other difficulties arising from any future changes.

No license, whether express, implied, by estoppel or otherwise, is granted to any intellectual property rights by this document. Skyworks assumes no liability for any materials, products or information provided hereunder, including the sale, distribution, reproduction or use of Skyworks products, information or materials, except as may be provided in Skyworks Terms and Conditions of Sale.

THE MATERIALS, PRODUCTS AND INFORMATION ARE PROVIDED “AS IS” WITHOUT WARRANTY OF ANY KIND, WHETHER EXPRESS, IMPLIED, STATUTORY, OR OTHERWISE, INCLUDING FITNESS FOR A PARTICULAR PURPOSE OR USE, MERCHANTABILITY, PERFORMANCE, QUALITY OR NON-INFRINGEMENT OF ANY INTELLECTUAL PROPERTY RIGHT; ALL SUCH WARRANTIES ARE HEREBY EXPRESSLY DISCLAIMED. SKYWORKS DOES NOT WARRANT THE ACCURACY OR COMPLETENESS OF THE INFORMATION, TEXT, GRAPHICS OR OTHER ITEMS CONTAINED WITHIN THESE MATERIALS. SKYWORKS SHALL NOT BE LIABLE FOR ANY DAMAGES, INCLUDING BUT NOT LIMITED TO ANY SPECIAL, INDIRECT, INCIDENTAL, STATUTORY, OR CONSEQUENTIAL DAMAGES, INCLUDING WITHOUT LIMITATION, LOST REVENUES OR LOST PROFITS THAT MAY RESULT FROM THE USE OF THE MATERIALS OR INFORMATION, WHETHER OR NOT THE RECIPIENT OF MATERIALS HAS BEEN ADVISED OF THE POSSIBILITY OF SUCH DAMAGE.



Skyworks products are not intended for use in medical, lifesaving or life-sustaining applications, or other equipment in which the failure of the Skyworks products could lead to personal injury, death, physical or environmental damage. Skyworks customers using or selling Skyworks products for use in such applications do so at their own risk and agree to fully indemnify Skyworks for any damages resulting from such improper use or sale.

Customers are responsible for their products and applications using Skyworks products, which may deviate from published specifications as a result of design defects, errors, or operation of products outside of published parameters or design specifications. Customers should include design and operating safeguards to minimize these and other risks. Skyworks assumes no liability for applications assistance, customer product design, or damage to any equipment resulting from the use of Skyworks products outside of stated published specifications or parameters.

Skyworks and the Skyworks symbol are trademarks or registered trademarks of Skyworks Solutions, Inc. or its subsidiaries in the United States and other countries. Third-party brands and names are for identification purposes only, and are the property of their respective owners. Additional information, including relevant terms and conditions, posted at [www.skyworksinc.com](http://www.skyworksinc.com), are incorporated by reference.

## Looking for pricing, stock, or lifecycle information?

Click below to explore more details on WIN SOURCE:

-  [View SKY13456-11 on WIN SOURCE](#)
-  [Skyworks Solutions Inc. Information](#)

## Optimize Your Supply Chain with WIN SOURCE Solutions

-  Global Sourcing Solution
-  Obsolete Management
-  Cost Control Management
-  Shortage Management
-  Alternative Solution
-  Excess Inventory Management