



**THE DATASHEET OF  
RT9610CGQW**



## High Voltage Synchronous Rectified Buck MOSFET Driver for Notebook Computer

### General Description

The RT9610C is a high frequency, dual MOSFET driver specifically designed to drive two power N-MOSFETS in a synchronous-rectified buck converter topology. It is especially suited for mobile computing applications that require high efficiency and excellent thermal performance. This driver, combined with Richtek's series of multi-phase Buck PWM controllers, provides a complete core voltage regulator solution for advanced microprocessors.

The drivers are capable of driving a 3nF load with fast rising/falling time and fast propagation delay. This device implements bootstrapping on the upper gates with only a single external capacitor. This reduces implementation complexity and allows the use of higher performance, cost effective, N-MOSFETS. Adaptive shoot through protection is integrated to prevent both MOSFETS from conducting simultaneously.

The RT9610C is available in WDFN-8L 2x2 Package.

### Marking Information

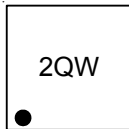

2Q : Product Code  
W : Date Code

### Features

- Drives Two N-MOSFETS
- Adaptive Shoot-Through Protection
- 0.5Ω On-Resistance, 4A Sink Current Capability
- Supports High Switching Frequency
- Tri-State PWM Input for Power Stage Shutdown
- Output Disable Function
- Integrated Boost Switch
- Low Bias Supply Current
- VCC POR Feature Integrated

### Applications

- Core Voltage Supplies for Intel® / AMD® Mobile Microprocessors
- High Frequency Low Profile DC/DC Converters
- High Current Low Output Voltage DC/DC Converters
- High Input Voltage DC/DC Converters

### Ordering Information

- RT9610C □ □
- Package Type  
QW : WDFN-8L 2x2 (W-Type)
  - Lead Plating System  
G : Green (Halogen Free and Pb Free)

Note :

Richtek products are :

- ▶ RoHS compliant and compatible with the current requirements of IPC/JEDEC J-STD-020.
- ▶ Suitable for use in SnPb or Pb-free soldering processes.

### Simplified Application Circuit

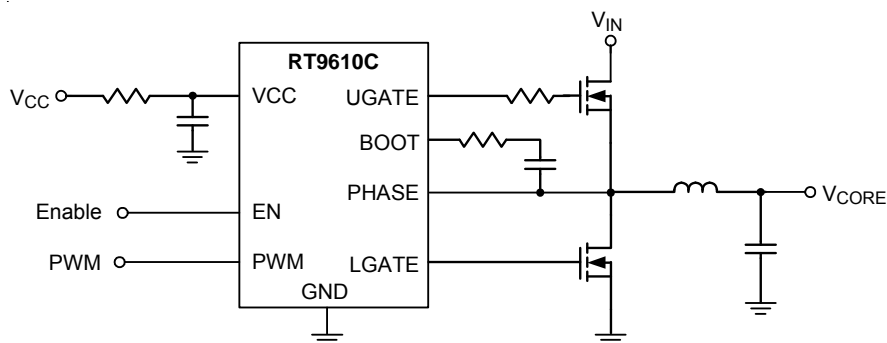

Pin Configurations

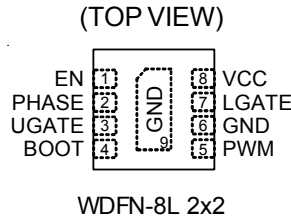

Functional Pin Description

Pin No.	Pin Name	Pin Function
1	EN	Enable Pin. When low, both UGATE and LGATE are driven low and the normal operation is disabled.
2	PHASE	Switch Node. Connect this pin to the source of the upper MOSFET and the drain of the lower MOSFET. This pin provides a return path for the upper gate driver.
3	UGATE	Upper Gate Drive Output. Connect to the gate of high side power N-MOSFET.
4	BOOT	Floating Bootstrap Supply Pin for Upper Gate Drive. Connect the bootstrap capacitor between this pin and the PHASE pin. The bootstrap capacitor provides the charge to turn on the upper MOSFET.
5	PWM	Control Input for Driver. The PWM signal can enter three distinct states during operation. Connect this pin to the PWM output of the controller.
6, 9 (Exposed Pad)	GND	Ground. The exposed pad must be soldered to a large PCB and connected to GND for maximum power dissipation.
7	LGATE	Lower Gate Drive Output. Connect to the gate of the low side power N-MOSFET.
8	VCC	Input Supply Pin. Connect this pin to a 5V bias supply. It is recommended adding RC filter (R = 2.2Ω/0603, C = 1μF/6.3V/0603/X5R) for noise suppression.

## Functional Block Diagram

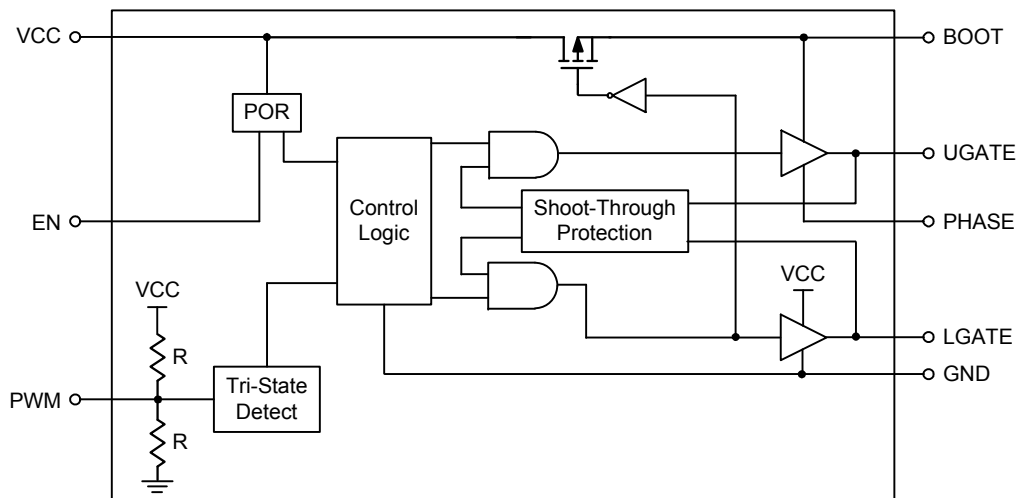

## Operation

### POR (Power On Reset)

POR block detects the voltage at the VCC pin. When the VCC pin voltage is higher than POR rising threshold, the POR pin output voltage (POR output) is high. POR output is low when VCC is not higher than POR rising threshold. When the POR pin voltage is high, UGATE and LGATE can be controlled by PWM input voltage. If the POR pin voltage is low, both UGATE and LGATE will be pulled to low.

### Tri-State Detect

When both POR output and EN pin voltages are high, UGATE and LGATE can be controlled by PWM input. There are three PWM input modes which are high, low, and shutdown state. If PWM input is within the shutdown window, both UGATE and LGATE outputs are low. When PWM input is higher than its rising threshold, UGATE is high and LGATE is low. When PWM input is lower than its falling threshold, UGATE is low and LGATE is high.

### Control Logic

Control logic block detects whether high side MOSFET is turned off by monitoring (UGATE - PHASE) voltages below 1.1V or PHASE voltage below 2V. To prevent the overlap of the gate drives during the UGATE pulls low and the LGATE pulls high, low side MOSFET can be turned on only after high side MOSFET is effectively turned off.

### Shoot-Through Protection

Shoot-through protection block implements the dead-time when both high side and low side MOSFETs are turned off. With shoot-through protection block, high side and low side MOSFETs are never turned on simultaneously. Thus, shoot-through between high side and low side MOSFETs is prevented.

## Absolute Maximum Ratings (Note 1)

- Supply Voltage, VCC ----- -0.3V to 6V
- BOOT to PHASE ----- -0.3V to 6V
- PHASE to GND
  - DC ----- -0.3V to 32V
  - < 20ns ----- -8V to 38V
- UGATE to PHASE
  - DC ----- -0.3V to 6V
  - < 20ns ----- -5V to 7.5V
- LGATE to GND
  - DC ----- -0.3V to 6V
  - < 20ns ----- -2.5V to 7.5V
- PWM, EN to GND ----- -0.3V to 6V
- Power Dissipation, P<sub>D</sub> @ T<sub>A</sub> = 25°C
  - WDFN-8L 2x2 ----- 2.19W
- Package Thermal Resistance (Note 2)
  - WDFN-8L 2x2, θ<sub>JA</sub> ----- 45.5°C/W
  - WDFN-8L 2x2, θ<sub>JC</sub> ----- 11.5°C/W
- Junction Temperature ----- 150°C
- Lead Temperature (Soldering, 10 sec.) ----- 260°C
- Storage Temperature Range ----- -65°C to 150°C
- ESD Susceptibility (Note 3)
  - HBM (Human Body Model) ----- 2kV

## Recommended Operating Conditions (Note 4)

- Input Voltage, V<sub>IN</sub> ----- 4.5V to 26V
- Control Voltage, VCC ----- 4.5V to 5.5V
- Ambient Temperature Range ----- -40°C to 85°C
- Junction Temperature Range ----- -40°C to 125°C

## Electrical Characteristics

(V<sub>CC</sub> = 5V, T<sub>A</sub> = 25°C, unless otherwise specified)

Parameter	Symbol	Test Conditions	Min	Typ	Max	Unit
<b>VCC Supply Current</b>						
Quiescent Current	I <sub>Q</sub>	PWM Pin Floating, V <sub>EN</sub> = 3.3V	--	80	--	μA
Shutdown Current	I <sub>SHDN</sub>	V <sub>EN</sub> = 0V, PWM = 0V, V <sub>CC</sub> = 5V	--	0	5	μA
VCC Power On Reset (POR)	V <sub>PORH</sub>	VCC POR Rising	--	4.2	4.5	V
	V <sub>PORL</sub>	VCC POR Falling	3.5	3.84	--	V
	V <sub>PORHYS</sub>	Hysteresis	--	360	--	mV
<b>Internal BOOT Switch</b>						
Internal Boost Switch On Resistance	R <sub>BOOT</sub>	VCC to BOOT, 10mA	--	--	80	Ω

Parameter	Symbol	Test Conditions	Min	Typ	Max	Unit	
<b>PWM Input</b>							
Input Current	IPWM	V <sub>PWM</sub> = 5V	--	174	--	μA	
		V <sub>PWM</sub> = 0V	--	-174	--		
PWM Tri-State Rising Threshold	V <sub>PWMH</sub>	V <sub>CC</sub> = 5V	3.5	3.8	4.1	V	
PWM Tri-State Falling Threshold	V <sub>PWML</sub>	V <sub>CC</sub> = 5V	0.7	1	1.3	V	
<b>EN Input</b>							
EN Input Voltage	Logic-High	V <sub>ENH</sub>	V <sub>CC</sub> = 5V	1.4	--	--	V
	Logic-Low	V <sub>ENL</sub>	V <sub>CC</sub> = 5V	--	--	0.48	
<b>Switching Time</b>							
UGATE Rise Time	t <sub>UGATEr</sub>	V <sub>CC</sub> = 5V, 3nF Load	--	8	--	ns	
UGATE Fall Time	t <sub>UGATEf</sub>	V <sub>CC</sub> = 5V, 3nF Load	--	8	--	ns	
LGATE Rise Time	t <sub>LGATEr</sub>	V <sub>CC</sub> = 5V, 3nF Load	--	8	--	ns	
LGATE Fall Time	t <sub>LGATEf</sub>	V <sub>CC</sub> = 5V, 3nF Load	--	4	--	ns	
UGATE Turn-Off Propagation Delay	t <sub>PDLU</sub>	V <sub>CC</sub> = 5V, Outputs Unloaded	--	35	--	ns	
LGATE Turn-Off Propagation Delay	t <sub>PDLL</sub>	V <sub>CC</sub> = 5V, Outputs Unloaded	--	35	--	ns	
UGATE Turn-On Propagation Delay	t <sub>PDHU</sub>	V <sub>CC</sub> = 5V, Outputs Unloaded	--	20	--	ns	
LGATE Turn-On Propagation Delay	t <sub>PDHL</sub>	V <sub>CC</sub> = 5V, Outputs Unloaded	--	20	--	ns	
UGATE/LGATE Tri-State Propagation Delay	t <sub>PTS</sub>	V <sub>CC</sub> = 5V, Outputs Unloaded	--	35	--	ns	
<b>Output</b>							
UGATE Driver Source Resistance	R <sub>UGATEsr</sub>	100mA Source Current	--	1	--	Ω	
UGATE Driver Source Current	I <sub>UGATEsr</sub>	V <sub>UGATE</sub> - V <sub>PHASE</sub> = 2.5V	--	2	--	A	
UGATE Driver Sink Resistance	R <sub>UGATEsk</sub>	100mA Sink Current	--	1	--	Ω	
UGATE Driver Sink Current	I <sub>UGATEsk</sub>	V <sub>UGATE</sub> - V <sub>PHASE</sub> = 2.5V	--	2	--	A	
LGATE Driver Source Resistance	R <sub>LGATEsr</sub>	100mA Source Current	--	1	--	Ω	
LGATE Driver Source Current	I <sub>LGATEsr</sub>	V <sub>LGATE</sub> = 2.5V	--	2	--	A	
LGATE Driver Sink Resistance	R <sub>LGATEsk</sub>	100mA Sink Current	--	0.5	--	Ω	
LGATE Driver Sink Current	I <sub>LGATEsk</sub>	V <sub>LGATE</sub> = 2.5V	--	4	--	A	

**Note 1.** Stresses beyond those listed “Absolute Maximum Ratings” may cause permanent damage to the device. These are stress ratings only, and functional operation of the device at these or any other conditions beyond those indicated in the operational sections of the specifications is not implied. Exposure to absolute maximum rating conditions may affect device reliability.

**Note 2.** θ<sub>JA</sub> is measured at T<sub>A</sub> = 25°C on a high effective thermal conductivity four-layer test board per JEDEC 51-7. θ<sub>JC</sub> is measured at the exposed pad of the package.

**Note 3.** Devices are ESD sensitive. Handling precautions are recommended. The human body mode is a 100pF capacitor is charged through a 1.5kΩ resistor into each pin.

**Note 4.** The device is not guaranteed to function outside its operating conditions.

## Typical Application Circuit

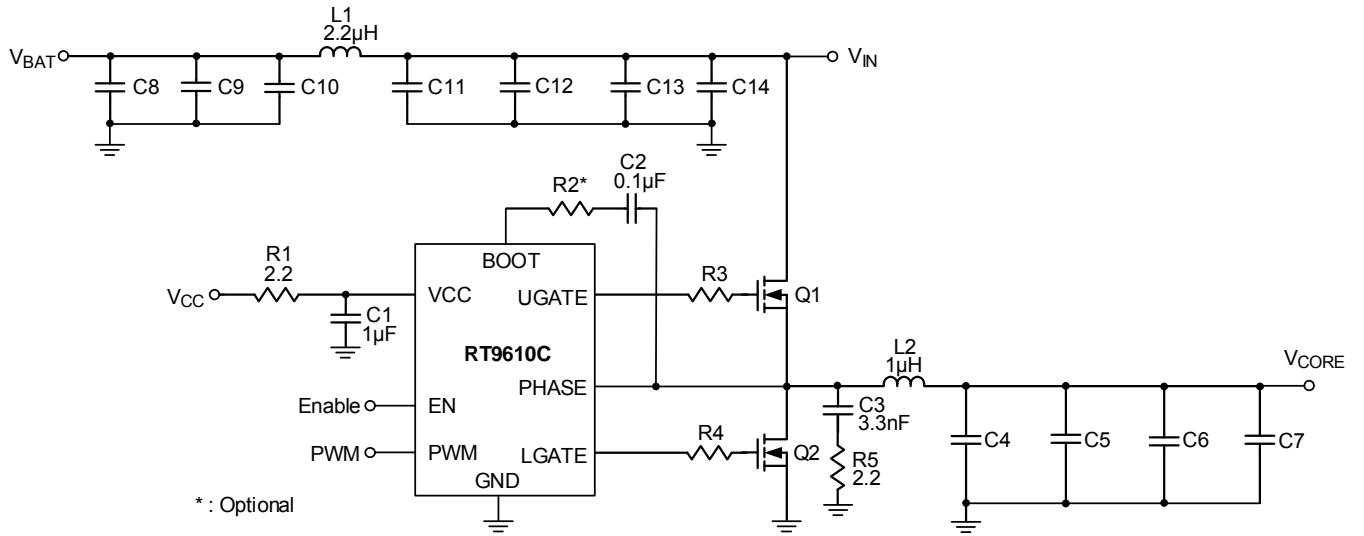

## Timing Diagram

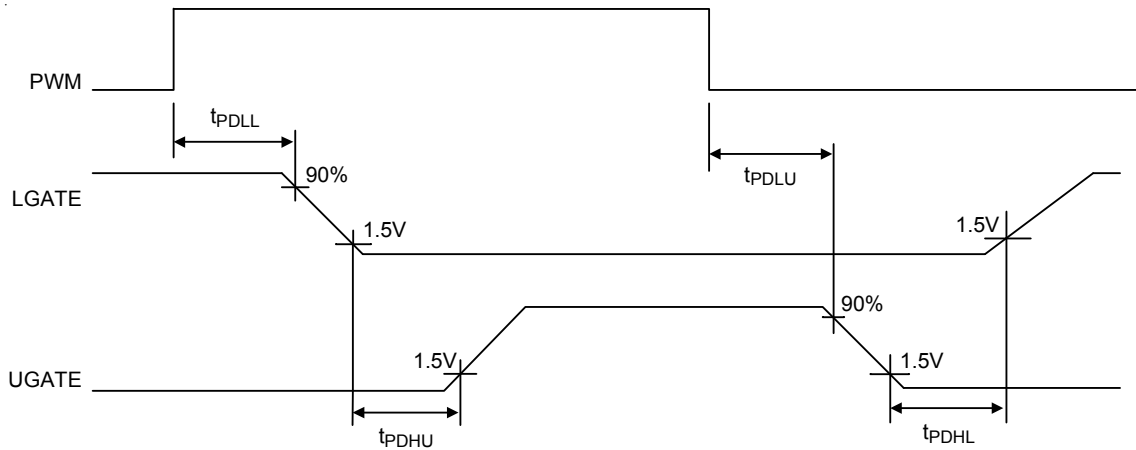

**Typical Operating Characteristics**

**Driver Enable**

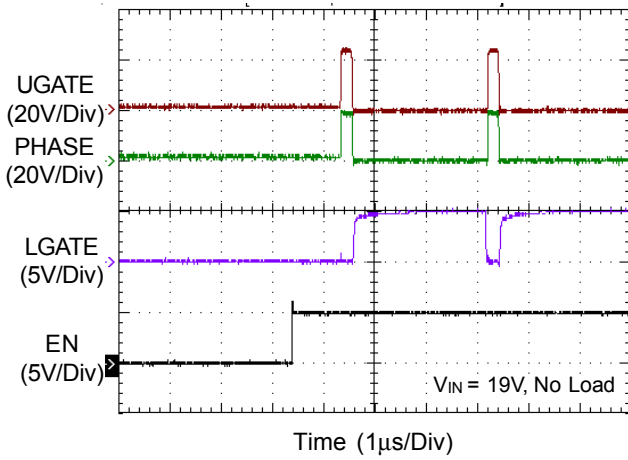

**Driver Disable**

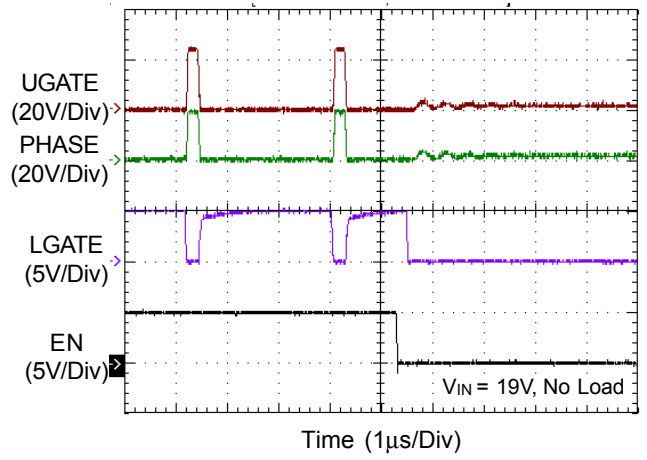

**PWM Rising Edge**

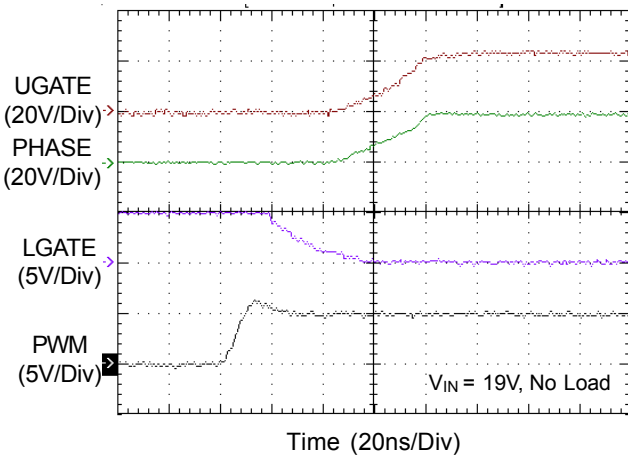

**PWM Falling Edge**

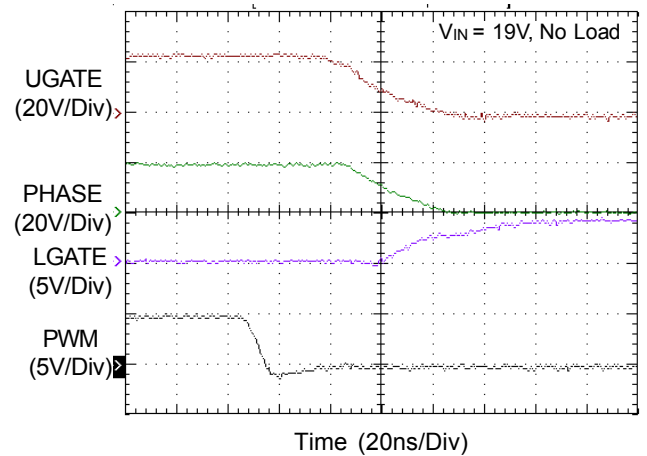

**Dead Time**

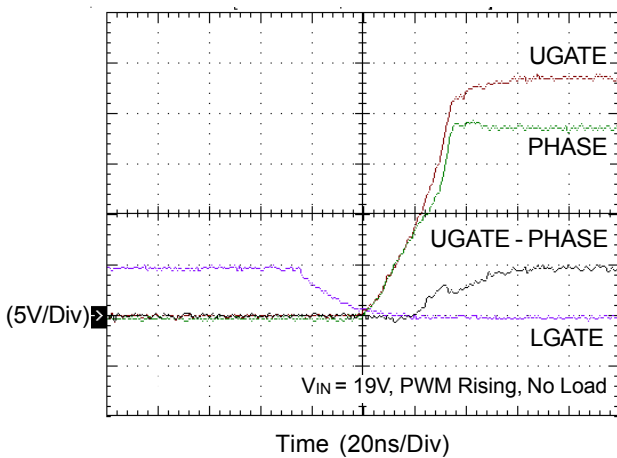

**Dead Time**

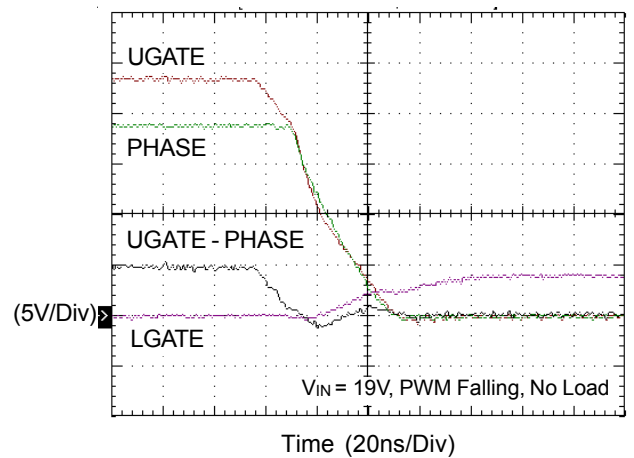

Dead Time

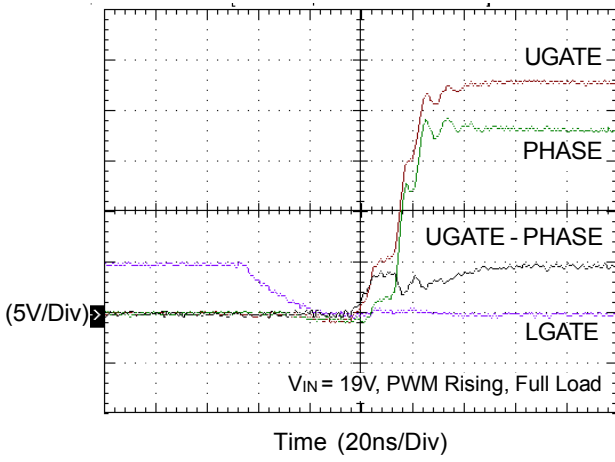

Dead Time

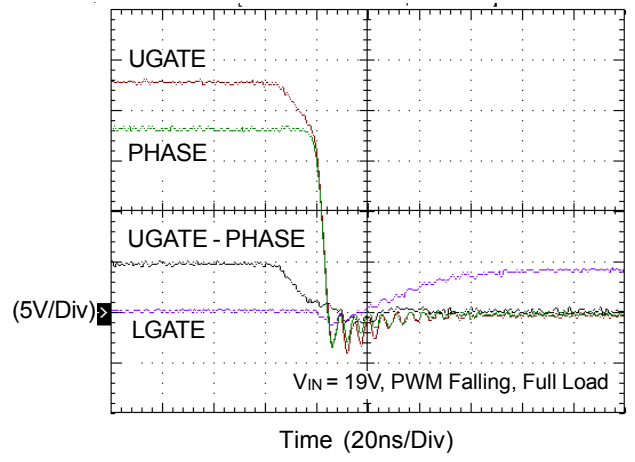

Short Pulse

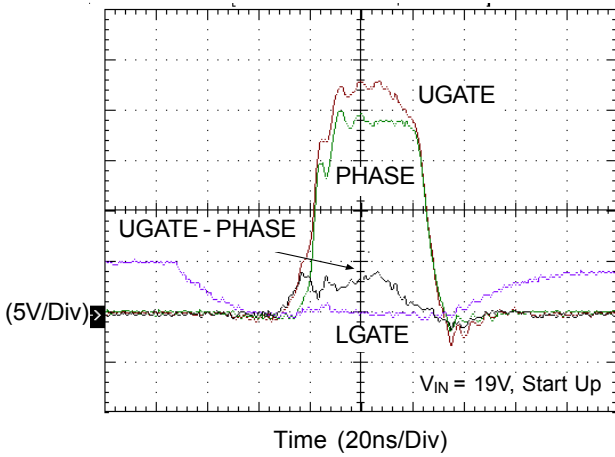

## Application Information

### Supply Voltage and Power On Reset

The RT9610C is designed to drive both high side and low side N-MOSFETs through an externally input PWM control signal. Connect 5V to VCC to power on the RT9610C. A minimum 1μF ceramic capacitor is recommended to bypass the supply voltage. Place the bypassing capacitor physically near the IC. The power on reset (POR) circuit monitors the supply voltage at the VCC pin. If VCC exceeds the POR rising threshold voltage, the controller resets and prepares for operation. UGATE and LGATE are held low before VCC is above the POR rising threshold.

### Enable and Disable

The RT9610C includes an EN pin for sequence control. When the EN pin rises above the  $V_{ENH}$  trip point, the RT9610C begins a new initialization and follows the PWM command to control the UGATE and LGATE. When the EN pin falls below the  $V_{ENL}$  trip point, the RT9610C shuts down and keeps UGATE and LGATE low.

### Three State PWM Input

After initialization, the PWM signal takes over the control. The rising PWM signal first forces the LGATE signal low and then allows the UGATE signal to go high right after a non-overlapping time to avoid shoot through current. In contrast, the falling PWM signal first forces UGATE to go low. When the UGATE or PHASE signal reach a predetermined low level, LGATE signal is then allowed to go high.

### Non-overlap Control

To prevent the overlap of the gate drives during the UGATE pull low and the LGATE pull high, the non-overlap circuit monitors the voltages at the PHASE node and high side gate drive (UGATE-PHASE). When the PWM input signal goes low, UGATE begins to pull low (after propagation delay). Before LGATE can pull high, the non-overlap protection circuit ensures that the monitored (UGATE-PHASE) voltages have gone below 1.1V or phase voltage is below 2V. Once the monitored voltages fall below the threshold, LGATE begins to turn high. By waiting for the voltages of the PHASE pin and high side gate drive to fall

below their threshold, the non-overlap protection circuit ensures that UGATE is low before LGATE pulls high.

Also to prevent the overlap of the gate drives during LGATE pull low and UGATE pull high, the non-overlap circuit monitors the LGATE voltage. When LGATE go below 1.1V, UGATE is allowed to go high.

### Driving Power MOSFETs

The DC input impedance of the power MOSFET is extremely high. The gate draws the current only for few nano-amperes. Thus once the gate has been driven up to "ON" level, the current could be negligible.

However, the capacitance at the gate to source terminal should be considered. It requires relatively large currents to drive the gate up and down rapidly. It is also required to switch drain current on and off with the required speed. The required gate drive currents are calculated as follows.

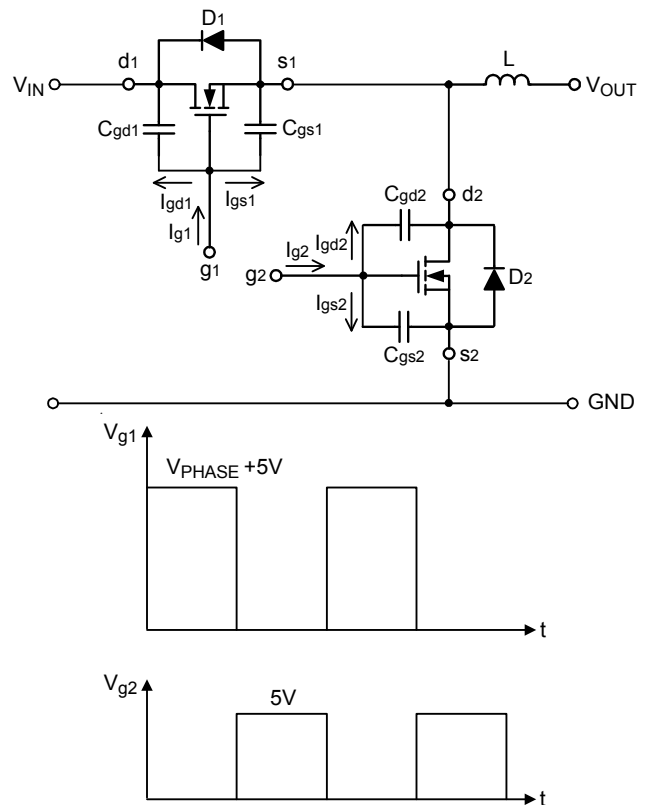

Figure1. Equivalent Circuit and Associated Waveforms

In Figure 1, the current  $I_{g1}$  and  $I_{g2}$  are required to move the gate up to 5V. The operation consists of charging  $C_{gd1}$ ,  $C_{gd2}$ ,  $C_{gs1}$  and  $C_{gs2}$ .  $C_{gs1}$  and  $C_{gs2}$  are the capacitors from gate to source of the high side and the low side power MOSFETs, respectively. In general data sheets, the  $C_{gs1}$  and  $C_{gs2}$  are referred as " $C_{iss}$ " which are the input capacitors.  $C_{gd1}$  and  $C_{gd2}$  are the capacitors from gate to drain of the high side and the low side power MOSFETs, respectively and referred to the data sheets as " $C_{rss}$ " the reverse transfer capacitance. For example,  $t_{r1}$  and  $t_{r2}$  are the rising time of the high side and the low side power MOSFETs respectively, the required current  $I_{gs1}$  and  $I_{gs2}$ , are shown as below :

$$I_{gs1} = C_{gs1} \frac{dV_{g1}}{dt} = \frac{C_{gs1} \times 5}{t_{r1}} \quad (1)$$

$$I_{gs2} = C_{gs2} \frac{dV_{g2}}{dt} = \frac{C_{gs2} \times 5}{t_{r2}} \quad (2)$$

Before driving the gate of the high side MOSFET up to 5V, the low side MOSFET has to be off; and the high side MOSFET is turned off before the low side is turned on. From Figure 1, the body diode " $D_2$ " had been turned on before high side MOSFETs turned on.

$$I_{gd1} = C_{gd1} \frac{dV}{dt} = C_{gd1} \frac{5}{t_{r1}} \quad (3)$$

Before the low side MOSFET is turned on, the  $C_{gd2}$  have been charged to  $V_{IN}$ . Thus, as  $C_{gd2}$  reverses its polarity and  $g_2$  is charged up to 5V, the required current is :

$$I_{gd2} = C_{gd2} \frac{dV}{dt} = C_{gd2} \frac{V_i + 5}{t_{r2}} \quad (4)$$

It is helpful to calculate these currents in a typical case. Assume a synchronous rectified buck converter, input voltage  $V_{IN} = 12V$ ,  $V_{g1} = V_{g2} = 5V$ . The high side MOSFET is PHB83N03LT whose  $C_{iss} = 1660pF$ ,  $C_{rss} = 380pF$ , and  $t_r = 14ns$ . The low side MOSFET is PHB95N03LT whose  $C_{iss} = 2200pF$ ,  $C_{rss} = 500pF$  and  $t_r = 30ns$ , from the equation (1) and (2) we can obtain :

$$I_{gs1} = \frac{1660 \times 10^{-12} \times 5}{14 \times 10^{-9}} = 0.593 \quad (A) \quad (5)$$

$$I_{gs2} = \frac{2200 \times 10^{-12} \times 5}{30 \times 10^{-9}} = 0.367 \quad (A) \quad (6)$$

from equation. (3) and (4)

$$I_{gd1} = \frac{380 \times 10^{-12} \times 5}{14 \times 10^{-9}} = 0.136 \quad (A) \quad (7)$$

$$I_{gd2} = \frac{500 \times 10^{-12} \times (12+5)}{30 \times 10^{-9}} = 0.283 \quad (A) \quad (8)$$

the total current required from the gate driving source can be calculated as following equations :

$$I_{g1} = I_{gs1} + I_{gd1} = (0.593 + 0.136) = 0.729 \quad (A) \quad (9)$$

$$I_{g2} = I_{gs2} + I_{gd2} = (0.367 + 0.283) = 0.65 \quad (A) \quad (10)$$

By a similar calculation, we can also get the sink current required from the turned off MOSFET.

### Bootstrap Circuit Component Selection

For saving more power consumption, the transitional bootstrap circuit is replaced by FET switch which is integrated to RT9610C for more space saving. Now, only connect an external capacitor ( $C_{BOOT}$ ) between BOOT and PHASE. For effectively turning the high-side MOSFET on, the storage energy in  $C_{BOOT}$  needs to greater than the total gate charge of high-side MOSFET.

Figure 2 shows part of the bootstrap circuit of the RT9610C. As can be seen from Figure 2, the gate charge of high-side and low-side MOSFETs are defined as  $Q_{gH}$  and  $Q_{gL}$ , respectively. For charging the  $C_{BOOT}$ , internal bootstrap switch and low-side MOSFET are turned on simultaneously to build the charging path from VCC, and the sum of  $C_{BOOT}$  charging current and low-side MOSFET driving current is defined as  $I_{VCC}$ . As result, the voltage  $V_{CBOOT}$  on  $C_{BOOT}$  can be represented as

$$V_{CBOOT} = V_{DRV} \frac{V_{IN} f_{sw}}{V_{IN} - V_{OUT}} \left[ (Q_{gH} + Q_{gL}) R_1 + Q_{gH} (R_{BOOT(max)} + R_{BOOT_ext}) \right]$$

Where

$V_{IN}$  : Input voltage

$V_{OUT}$  : Output voltage

$V_{DRV}$  : Supply voltage to VCC

$f_{sw}$  : Switching frequency

$R_{BOOT(max)}$  : Internal boost switch on resistance

$R_{BOOT_ext}$  : External bootstrap resistor

Calculating  $V_{CBOOT}$  is essential to ensure MOSFET safe operation in ohmic region. As result,  $V_{CBOOT}$  must be larger enough to avoid high-side MOSFET being incomplete turned on.

The value of bootstrap capacitor is defined by :

$$C_{BOOT} \geq \frac{Q_{gH}}{\Delta V_{CBOOT}}$$

Where

$\Delta V_{CBOOT}$  : Maximum allowable voltage drop on bootstrap capacitor.

In practice, a low value capacitor  $C_{BOOT}$  will lead to the over charging that could damage the IC. Therefore, to minimize the risk of overcharging and to reduce the ripple on  $C_{BOOT}$ , the bootstrap capacitor should not be smaller than 0.1 $\mu$ F. At least one low-ESR capacitor should be used to provide good local de-coupling. It is recommended to adopt a ceramic or tantalum capacitor. Furthermore, the  $C_{BOOT}$  is more important to be considered because the less  $C_{BOOT}$  charging time is occurred in fast VID change and fast soft-start application. The  $C_{BOOT}$  charging time is regarding to the inductor, the output capacitor and different operation frequency. For selecting the suitable value of  $C_{BOOT}$  in these applications, please contact our sales representative directly or through a Richtek distributor located in your area.

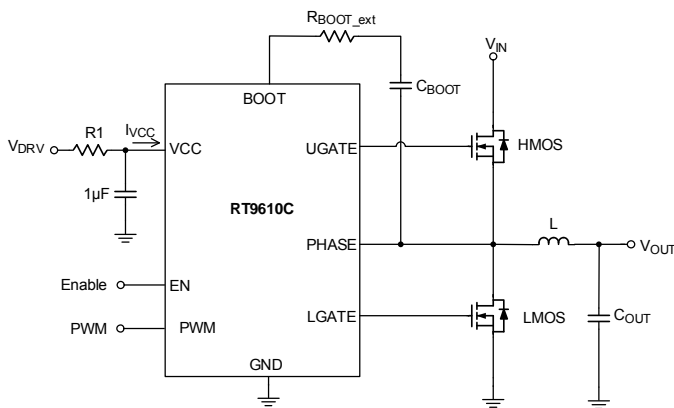

Figure 2. Part of Bootstrap Circuit of RT9610C

**Thermal Considerations**

For continuous operation, do not exceed absolute maximum junction temperature. The maximum power dissipation depends on the thermal resistance of the IC package, PCB layout, rate of surrounding airflow, and difference between junction and ambient temperature. The maximum power dissipation can be calculated by the following formula :

$$P_{D(MAX)} = (T_{J(MAX)} - T_A) / \theta_{JA}$$

where  $T_{J(MAX)}$  is the maximum junction temperature,  $T_A$  is the ambient temperature, and  $\theta_{JA}$  is the junction to ambient thermal resistance.

For recommended operating condition specifications, the maximum junction temperature is 125°C. The junction to ambient thermal resistance,  $\theta_{JA}$ , is layout dependent. For WDFN-8L 2x2 packages, the thermal resistance,  $\theta_{JA}$ , is 45.5°C/W on a standard JEDEC 51-7 four-layer thermal test board. The maximum power dissipation at  $T_A = 25^\circ\text{C}$  can be calculated by the following formula :

$$P_{D(MAX)} = (125^\circ\text{C} - 25^\circ\text{C}) / (45.5^\circ\text{C/W}) = 2.19\text{W for WDFN-8L 2x2 package}$$

The maximum power dissipation depends on the operating ambient temperature for fixed  $T_{J(MAX)}$  and thermal resistance,  $\theta_{JA}$ . The derating curves in Figure 3 allow the designer to see the effect of rising ambient temperature on the maximum power dissipation.

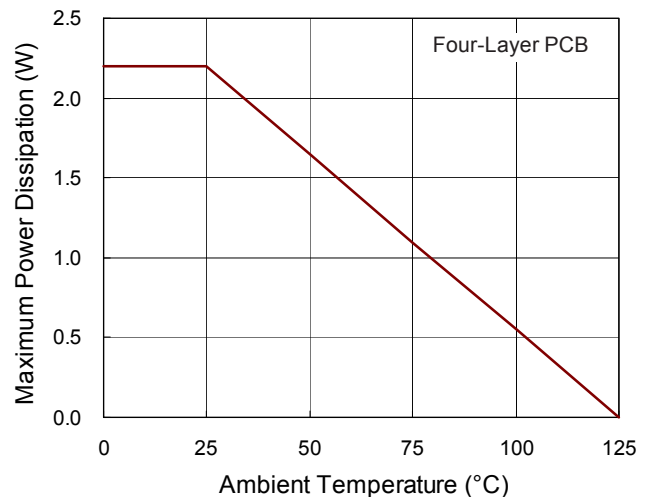

Figure 3. Derating Curve of Maximum Power Dissipation

## Layout Considerations

Figure 4 shows the schematic circuit of a synchronous buck converter to implement the RT9610C.

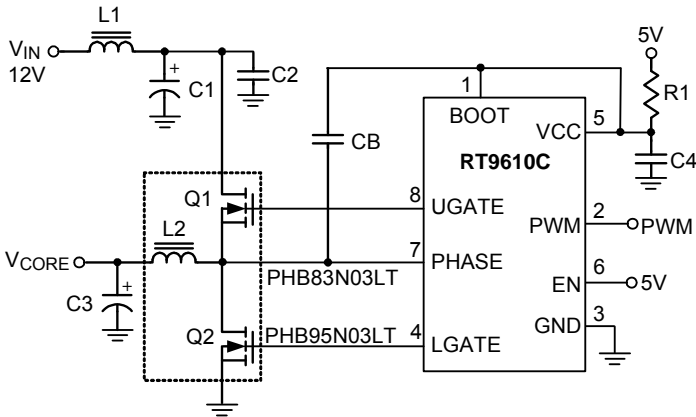
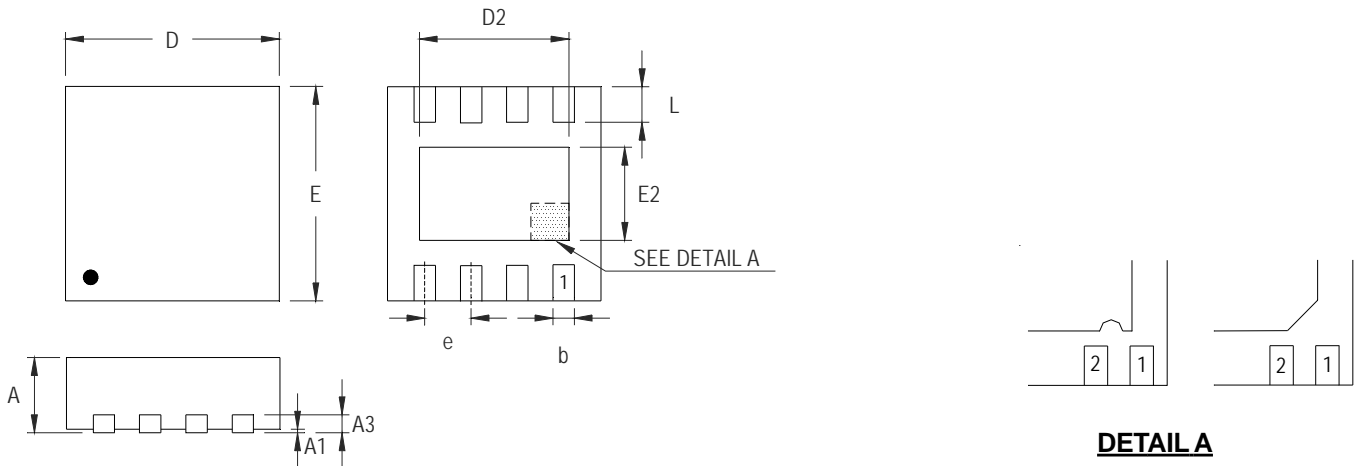

Figure 4. Synchronous Buck Converter Circuit

When layout the PCB, it should be very careful. The power circuit section is the most critical one. If not configured properly, it will generate a large amount of EMI. The junction of Q1, Q2, L2 should be very close.

Next, the trace from UGATE, and LGATE should also be short to decrease the noise of the driver output signals. PHASE signals from the junction of the power MOSFET, carrying the large gate drive current pulses, should be as heavy as the gate drive trace. The bypass capacitor C4 should be connected to GND directly. Furthermore, the bootstrap capacitors (C<sub>B</sub>) should always be placed as close to the pins of the IC as possible.

**Outline Dimension**



**DETAIL A**

Pin #1 ID and Tie Bar Mark Options

Note : The configuration of the Pin #1 identifier is optional, but must be located within the zone indicated.

Symbol	Dimensions In Millimeters		Dimensions In Inches	
	Min	Max	Min	Max
A	0.700	0.800	0.028	0.031
A1	0.000	0.050	0.000	0.002
A3	0.175	0.250	0.007	0.010
b	0.200	0.300	0.008	0.012
D	1.950	2.050	0.077	0.081
D2	1.000	1.250	0.039	0.049
E	1.950	2.050	0.077	0.081
E2	0.400	0.650	0.016	0.026
e	0.500		0.020	
L	0.300	0.400	0.012	0.016

**W-Type 8L DFN 2x2 Package**

**Richtek Technology Corporation**

14F, No. 8, Tai Yuen 1<sup>st</sup> Street, Chupei City  
 Hsinchu, Taiwan, R.O.C.  
 Tel: (8863)5526789

## Looking for pricing, stock, or lifecycle information?

Click below to explore more details on WIN SOURCE:

 [View RT9610CGQW on WIN SOURCE](#)

 [Richtek USA Inc. Information](#)

## Optimize Your Supply Chain with WIN SOURCE Solutions

-  Global Sourcing Solution
-  Obsolete Management
-  Cost Control Management
-  Shortage Management
-  Alternative Solution
-  Excess Inventory Management