



THE DATASHEET OF P6KE200A-AP



	E480232
---	----------------

Features

- Economical Series
- Available in Both Unidirectional and Bidirectional construction and Suffix "C" Designates Bidirectional Type
- Halogen Free Available Upon Request By Adding Suffix "-HF"
- Epoxy Meets UL 94 V-0 Flammability Rating
- Lead Free Finish/RoHS Compliant ("P" Suffix Designates RoHS Compliant. See Ordering Information)

Mechanical Data

- Weight: 0.4 Gram(Appx.).
- Mounting Position: Any.
- Polarity: Banded Denotes Cathode. Bidirectional Not Marked.

Application

- Use in Sensitive Electronics Protection Against Voltage Transients Induced by Inductive Load Switching and Lighting on ICs, MOSFET, Signal Lines of Sensor Units for Consumer, Computer, Industrial, Automotive and Telecommunication.

Maximum Ratings

- 3/8" Lead Length
- Operating Junction Temperature Range: -55°C to +175°C
- Storage Temperature Range: -55°C to +175°C

Peak Pulse Power Dissipation	P _{PP}	600W	T _A =25°C
Steady State Power Dissipation	P _D	5.0 W	T _L =75°C
t _{clamping} (0 Volts to V _(BR) Min)	Unidirectional 1×10^{-12} Seconds;		
	Bidirectional 5×10^{-9} Seconds		

1.High Temperature Solder Exemption Applied, see EU Directive Annex 7a.

**600WATTS TVS
6.8 to 600 VOLTS**

DO-15

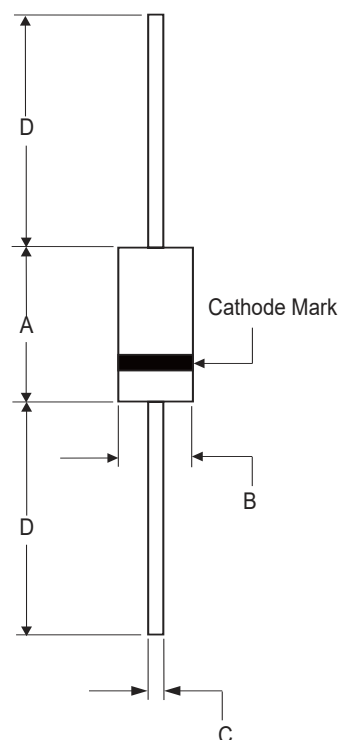

DIM	INCHES		MM		NOTE
	MIN	MAX	MIN	MAX	
A	0.230	0.300	5.80	7.60	
B	0.104	0.140	2.60	3.60	
C	0.026	0.035	0.70	0.90	
D	1.000	-----	25.40	-----	

MCC PART NUMBER	BREAKDOWN VOLTAGE $V_{(BR)} @ I_T$ (VOLTS)			TEST CURRENT I_T	RATED STANDOFF VOLTAGE V_{WM}	MAXIMUM REVERSE LEAKAGE $I_D @ V_{WM}$	MAXIMUM CLAMPING VOLTAGE $V_C @ I_{PP}$	MAXIMUM PEAK PULSE CURRENT I_{PP}	MAX. TEMP COEFFICIENT OF VBR $V_{(BR)} (TA)$ -55°C TO 100°C
	MIN	NOM	MAX						
P6KE6.8	6.12	6.8	7.48	10	5.5	1000	10.8	56	0.057
P6KE6.8A	6.45	6.8	7.14	10	5.8	1000	10.5	57	0.057
P6KE7.5	6.75	7.5	8.25	10	6.05	500	11.7	51	0.061
P6KE7.5A	7.13	7.5	7.88	10	6.4	500	11.3	53	0.061
P6KE8.2	7.38	8.2	9.02	10	6.63	200	12.5	48	0.065
P6KE8.2A	7.79	8.2	8.61	10	7.02	200	12.1	50	0.065
P6KE9.1	8.19	9.1	10	1	7.37	50	13.8	44	0.068
P6KE9.1A	8.65	9.1	9.55	1	7.78	50	13.4	45	0.068
P6KE10	9.0	10	11	1	8.1	10	15	40	0.073
P6KE10A	9.5	10	10.5	1	8.55	10	14.5	41	0.073
P6KE11	9.9	11	12.1	1	8.92	5	16.2	37	0.075
P6KE11A	10.5	11	11.6	1	9.4	5	15.6	38	0.075
P6KE12	10.8	12	13.2	1	9.72	5	17.3	35	0.078
P6KE12A	11.4	12	12.6	1	10.2	5	16.7	36	0.078
P6KE13	11.7	13	14.3	1	10.5	1	19	32	0.081
P6KE13A	12.4	13	13.7	1	11.1	1	18.2	33	0.081
P6KE15	13.5	15	16.5	1	12.1	1	22	27	0.084
P6KE15A	14.3	15	15.8	1	12.8	1	21.2	28	0.084
P6KE16	14.4	16	17.6	1	12.9	1	23.5	26	0.086
P6KE16A	15.2	16	16.8	1	13.6	1	22.5	27	0.086
P6KE18	16.2	18	19.8	1	14.5	1	26.5	23	0.088
P6KE18A	17.1	18	18.9	1	15.3	1	25.2	24	0.088
P6KE20	18	20	22	1	16.2	1	29.1	21	0.090
P6KE20A	19	20	21	1	17.1	1	27.7	22	0.090
P6KE22	19.8	22	24.2	1	17.8	1	31.9	19	0.092
P6KE22A	20.9	22	23.1	1	18.8	1	30.6	20	0.092
P6KE24	21.6	24	26.4	1	19.4	1	34.7	17	0.094
P6KE24A	22.8	24	25.2	1	20.5	1	33.2	18	0.094
P6KE27	24.3	27	29.7	1	21.8	1	39.1	15	0.096
P6KE27A	25.7	27	28.4	1	23.1	1	37.5	16	0.096
P6KE30	27	30	33	1	24.3	1	43.5	14	0.097
P6KE30A	28.5	30	31.5	1	25.6	1	41.4	14.4	0.097
P6KE33	29.7	33	36.3	1	26.8	1	47.7	12.6	0.098
P6KE33A	31.4	33	34.7	1	28.2	1	45.7	13.2	0.098
P6KE36	32.4	36	39.6	1	29.1	1	52	11.6	0.099
P6KE36A	34.2	36	37.8	1	30.8	1	49.9	12	0.099
P6KE39	35.1	39	42.9	1	31.6	1	56.4	10.6	0.100
P6KE39A	37.1	39	41	1	33.3	1	53.9	11.2	0.100
P6KE43	38.7	43	47.3	1	34.8	1	61.9	9.6	0.101
P6KE43A	40.9	43	45.2	1	36.8	1	59.3	10.1	0.101
P6KE47	42.3	47	51.7	1	38.1	1	67.8	8.9	0.101
P6KE47A	44.7	47	49.4	1	40.2	1	64.8	9.3	0.101
P6KE51	45.9	51	56.1	1	41.3	1	73.5	8.2	0.102
P6KE51A	48.5	51	53.6	1	43.6	1	70.1	8.6	0.102
P6KE56	50.4	56	61.6	1	45.4	1	80.5	7.4	0.103
P6KE56A	53.2	56	58.8	1	47.8	1	77	7.8	0.103
P6KE62	55.8	62	68.2	1	50.2	1	89	6.8	0.104

MCC PART NUMBER	BREAKDOWN VOLTAGE $V_{(BR)} @ I_T$ (VOLTS)			TEST CURRENT I_T mADC	RATED STANDOFF VOLTAGE V_{WM} V	MAXIMUM REVERSE LEAKAGE $I_D @ V_{WM}$ (μ A)	MAXIMUM CLAMPING VOLTAGE $V_C @ I_{PP}$ V	MAXIMUM PEAK PULSE CURRENT I_{PP} A	MAX. TEMP COEFFICIENT OF VBR $V_{(BR)} (TA)$ -55°C TO 100°C % / °C
	MIN	NOM	MAX						
P6KE62A	58.9	62	65.1	1	53	1	85	7.1	0.104
P6KE68	61.2	68	74.8	1	55.1	1	98	6.1	0.104
P6KE68A	64.6	68	71.4	1	58.1	1	92	6.5	0.104
P6KE75	67.5	75	82.5	1	60.7	1	108	5.5	0.105
P6KE75A	71.3	75	78.8	1	64.1	1	103	5.8	0.105
P6KE82	73.8	82	90.2	1	66.4	1	118	5.1	0.105
P6KE82A	77.9	82	86.1	1	70.1	1	113	5.3	0.105
P6KE91	81.9	91	100	1	73.7	1	131	4.5	0.106
P6KE91A	86.5	91	95.5	1	77.8	1	125	4.8	0.106
P6KE100	90	100	110	1	81	1	144	4.2	0.106
P6KE100A	95	100	105	1	85.5	1	137	4.4	0.106
P6KE110	99	110	121	1	89.2	1	158	3.8	0.107
P6KE110A	105	110	116	1	94	1	152	4.0	0.107
P6KE120	108	120	132	1	97.2	1	173	3.5	0.107
P6KE120A	114	120	126	1	102	1	165	3.6	0.107
P6KE130	117	130	143	1	105	1	187	3.2	0.108
P6KE130A	124	130	137	1	111	1	179	3.3	0.108
P6KE150	135	150	165	1	121	1	215	2.8	0.108
P6KE150A	143	150	158	1	128	1	207	2.9	0.108
P6KE160	144	160	176	1	130	1	230	2.6	0.108
P6KE160A	152	160	168	1	136	1	219	2.7	0.108
P6KE170	153	170	187	1	138	1	244	2.5	0.108
P6KE170A	161	170	179	1	145	1	234	2.6	0.108
P6KE180	162	180	198	1	146	1	258	2.3	0.108
P6KE180A	171	180	189	1	154	1	246	2.4	0.108
P6KE200	180	200	220	1	162	1	287	2.1	0.108
P6KE200A	190	200	210	1	171	1	274	2.2	0.108
P6KE220	198	220	242	1	175	1	344	1.8	0.108
P6KE220A	209	220	231	1	185	1	328	1.9	0.108
P6KE250	225	250	275	1	202	1	360	1.7	0.110
P6KE250A	237	250	263	1	214	1	344	1.8	0.110
P6KE300	270	300	330	1	243	1	430	1.4	0.110
P6KE300A	285	300	315	1	256	1	414	1.5	0.110
P6KE350	315	350	385	1	284	1	504	1.2	0.110
P6KE350A	332	350	368	1	300	1	482	1.3	0.110
P6KE400	360	400	440	1	324	1	574	1.05	0.110
P6KE400A	380	400	420	1	342	1	548	1.1	0.110
P6KE440	396	440	484	1	356	1	631	0.99	0.110
P6KE440A	418	440	462	1	376	1	600	1.04	0.110
P6KE480	432	480	528	1	389	1	686	0.88	0.110
P6KE480A	456	480	504	1	408	1	658	0.91	0.110
P6KE510	459	510	561	1	413	1	729	0.82	0.110
P6KE510A	485	510	535	1	434	1	698	0.86	0.110
P6KE540	486	540	594	1	437	1	772	0.78	0.110
P6KE540A	513	540	567	1	459	1	740	0.81	0.110
P6KE600	540	600	660	1	480	1	870	0.69	0.110
P6KE600A	570	600	630	1	512	1	828	0.75	0.110

For bidirectional type having V_{WM} of 10 volts and less, the I_R limit is double.
For parts without A, the VBR is $\pm 10\%$

MCC PART NUMBER	BREAKDOWN VOLTAGE $V_{(BR)} @ I_T$ (VOLTS)			TEST CURRENT I_T	RATED STANDOFF VOLTAGE V_{WM}	MAXIMUM REVERSE LEAKAGE $I_D @ V_{WM}$	MAXIMUM CLAMPING VOLTAGE $V_C @ I_{PP}$	MAXIMUM PEAK PULSE CURRENT I_{PP}	MAX. TEMP COEFFICIENT OF VBR $V_{(BR)} (TA)$ -55°C TO 100°C
	MIN	NOM	MAX						
P6KE6.8C	6.12	6.8	7.48	10	5.5	1000	10.8	56	0.057
P6KE6.8CA	6.45	6.8	7.14	10	5.8	1000	10.5	57	0.057
P6KE7.5C	6.75	7.5	8.25	10	6.05	500	11.7	51	0.061
P6KE7.5AC	7.13	7.5	7.88	10	6.4	500	11.3	53	0.061
P6KE8.2C	7.38	8.2	9.02	10	6.63	200	12.5	48	0.065
P6KE8.2CA	7.79	8.2	8.61	10	7.02	200	12.1	50	0.065
P6KE9.1C	8.19	9.1	10	1	7.37	50	13.8	44	0.068
P6KE9.1CA	8.65	9.1	9.55	1	7.78	50	13.4	45	0.068
P6KE10C	9.0	10	11	1	8.1	10	15	40	0.073
P6KE10CA	9.5	10	10.5	1	8.55	10	14.5	41	0.073
P6KE11C	9.9	11	12.1	1	8.92	5	16.2	37	0.075
P6KE11CA	10.5	11	11.6	1	9.4	5	15.6	38	0.075
P6KE12C	10.8	12	13.2	1	9.72	5	17.3	35	0.078
P6KE12CA	11.4	12	12.6	1	10.2	5	16.7	36	0.078
P6KE13C	11.7	13	14.3	1	10.5	1	19	32	0.081
P6KE13CA	12.4	13	13.7	1	11.1	1	18.2	33	0.081
P6KE15C	13.5	15	16.5	1	12.1	1	22	27	0.084
P6KE15CA	14.3	15	15.8	1	12.8	1	21.2	28	0.084
P6KE16C	14.4	16	17.6	1	12.9	1	23.5	26	0.086
P6KE16CA	15.2	16	16.8	1	13.6	1	22.5	27	0.086
P6KE18C	16.2	18	19.8	1	14.5	1	26.5	23	0.088
P6KE18CA	17.1	18	18.9	1	15.3	1	25.2	24	0.088
P6KE20C	18	20	22	1	16.2	1	29.1	21	0.090
P6KE20CA	19	20	21	1	17.1	1	27.7	22	0.090
P6KE22C	19.8	22	24.2	1	17.8	1	31.9	19	0.092
P6KE22CA	20.9	22	23.1	1	18.8	1	30.6	20	0.092
P6KE24C	21.6	24	26.4	1	19.4	1	34.7	17	0.094
P6KE24CA	22.8	24	25.2	1	20.5	1	33.2	18	0.094
P6KE27C	24.3	27	29.7	1	21.8	1	39.1	15	0.096
P6KE27CA	25.7	27	28.4	1	23.1	1	37.5	16	0.096
P6KE30C	27	30	33	1	24.3	1	43.5	14	0.097
P6KE30CA	28.5	30	31.5	1	25.6	1	41.4	14.4	0.097
P6KE33C	29.7	33	36.3	1	26.8	1	47.7	12.6	0.098
P6KE33CA	31.4	33	34.7	1	28.2	1	45.7	13.2	0.098
P6KE36C	32.4	36	39.6	1	29.1	1	52	11.6	0.099
P6KE36CA	34.2	36	37.8	1	30.8	1	49.9	12	0.099
P6KE39C	35.1	39	42.9	1	31.6	1	56.4	10.6	0.100
P6KE39CA	37.1	39	41	1	33.3	1	53.9	11.2	0.100
P6KE43C	38.7	43	47.3	1	34.8	1	61.9	9.6	0.101
P6KE43CA	40.9	43	45.2	1	36.8	1	59.3	10.1	0.101
P6KE47C	42.3	47	51.7	1	38.1	1	67.8	8.9	0.101
P6KE47CA	44.7	47	49.4	1	40.2	1	64.8	9.3	0.101
P6KE51C	45.9	51	56.1	1	41.3	1	73.5	8.2	0.102
P6KE51CA	48.5	51	53.6	1	43.6	1	70.1	8.6	0.102
P6KE56C	50.4	56	61.6	1	45.4	1	80.5	7.4	0.103
P6KE56CA	53.2	56	58.8	1	47.8	1	77	7.8	0.103
P6KE62C	55.8	62	68.2	1	50.2	1	89	6.8	0.104

MCC PART NUMBER	BREAKDOWN VOLTAGE $V_{(BR)} @ I_T$ (VOLTS)			TEST CURRENT I_T mADC	RATED STANDOFF VOLTAGE V_{WM} V	MAXIMUM REVERSE LEAKAGE $I_D @ V_{WM}$ (μ A)	MAXIMUM CLAMPING VOLTAGE $V_C @ I_{PP}$ V	MAXIMUM PEAK PULSE CURRENT I_{PP} A	MAX. TEMP COEFFICIENT OF VBR $V_{(BR)} (TA)$ -55°C TO 100°C % / °C
	MIN	NOM	MAX						
P6KE62CA	58.9	62	65.1	1	53	1	85	7.1	0.104
P6KE68C	61.2	68	74.8	1	55.1	1	98	6.1	0.104
P6KE68CA	64.6	68	71.4	1	58.1	1	92	6.5	0.104
P6KE75C	67.5	75	82.5	1	60.7	1	108	5.5	0.105
P6KE75CA	71.3	75	78.8	1	64.1	1	103	5.8	0.105
P6KE82C	73.8	82	90.2	1	66.4	1	118	5.1	0.105
P6KE82CA	77.9	82	86.1	1	70.1	1	113	5.3	0.105
P6KE91C	81.9	91	100	1	73.7	1	131	4.5	0.106
P6KE91CA	86.5	91	95.5	1	77.8	1	125	4.8	0.106
P6KE100C	90	100	110	1	81	1	144	4.2	0.106
P6KE100CA	95	100	105	1	85.5	1	137	4.4	0.106
P6KE110C	99	110	121	1	89.2	1	158	3.8	0.107
P6KE110CA	105	110	116	1	94	1	152	4.0	0.107
P6KE120C	108	120	132	1	97.2	1	173	3.5	0.107
P6KE120CA	114	120	126	1	102	1	165	3.6	0.107
P6KE130C	117	130	143	1	105	1	187	3.2	0.108
P6KE130CA	124	130	137	1	111	1	179	3.3	0.108
P6KE150C	135	150	165	1	121	1	215	2.8	0.108
P6KE150CA	143	150	158	1	128	1	207	2.9	0.108
P6KE160C	144	160	176	1	130	1	230	2.6	0.108
P6KE160CA	152	160	168	1	136	1	219	2.7	0.108
P6KE170C	153	170	187	1	138	1	244	2.5	0.108
P6KE170CA	161	170	179	1	145	1	234	2.6	0.108
P6KE180C	162	180	198	1	146	1	258	2.3	0.108
P6KE180CA	171	180	189	1	154	1	246	2.4	0.108
P6KE200C	180	200	220	1	162	1	287	2.1	0.108
P6KE200CA	190	200	210	1	171	1	274	2.2	0.108
P6KE220C	198	220	242	1	175	1	344	1.8	0.108
P6KE220CA	209	220	231	1	185	1	328	1.9	0.108
P6KE250C	225	250	275	1	202	1	360	1.7	0.110
P6KE250CA	237	250	263	1	214	1	344	1.8	0.110
P6KE300C	270	300	330	1	243	1	430	1.4	0.110
P6KE300CA	285	300	315	1	256	1	414	1.5	0.110
P6KE350C	315	350	385	1	284	1	504	1.2	0.110
P6KE350CA	332	350	368	1	300	1	482	1.3	0.110
P6KE400C	360	400	440	1	324	1	574	1.05	0.110
P6KE400CA	380	400	420	1	342	1	548	1.1	0.110
P6KE440C	396	440	484	1	356	1	631	0.99	0.110
P6KE440CA	418	440	462	1	376	1	600	1.04	0.110
P6KE480C	432	480	528	1	389	1	686	0.88	0.110
P6KE480CA	456	480	504	1	408	1	658	0.91	0.110
P6KE510C	459	510	561	1	413	1	729	0.82	0.110
P6KE510CA	485	510	535	1	434	1	698	0.86	0.110
P6KE540C	486	540	594	1	437	1	772	0.78	0.110
P6KE540CA	513	540	567	1	459	1	740	0.81	0.110
P6KE600C	540	600	660	1	480	1	870	0.69	0.110
P6KE600CA	570	600	630	1	512	1	828	0.75	0.110

For bidirectional type having V_{WM} of 10 volts and less, the I_R limit is double.
For parts without A, the VBR is $\pm 10\%$

Curve Characteristics

Fig. 1 - Peak Pulse Power Rating Curve

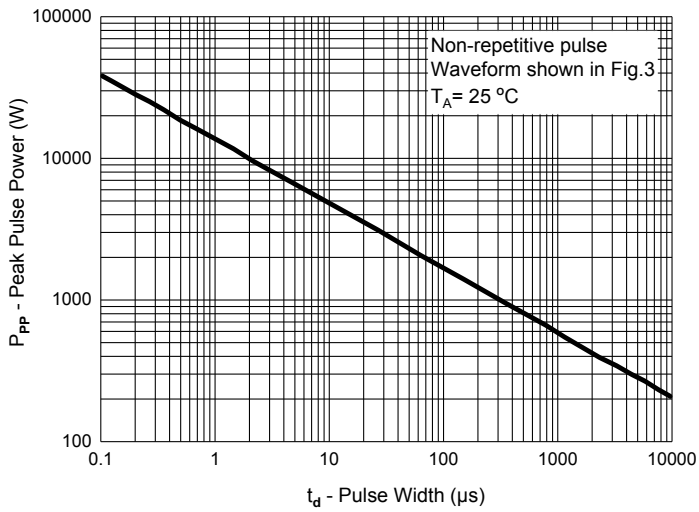

Fig. 2 - Typical Junction Capacitance

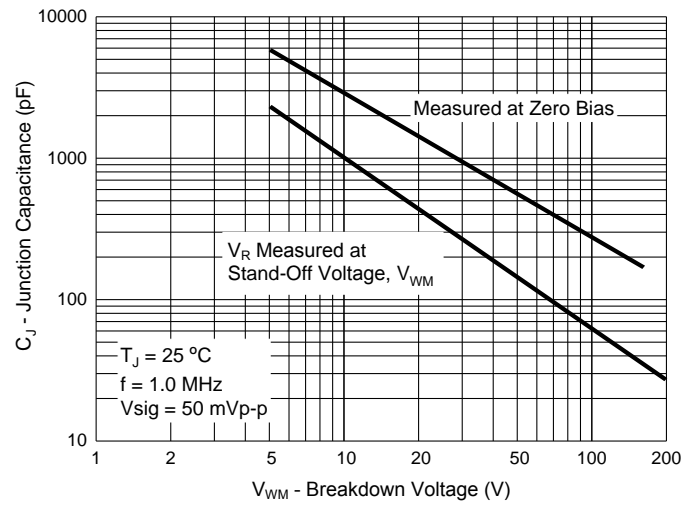

Fig. 3 - Pulse Waveform

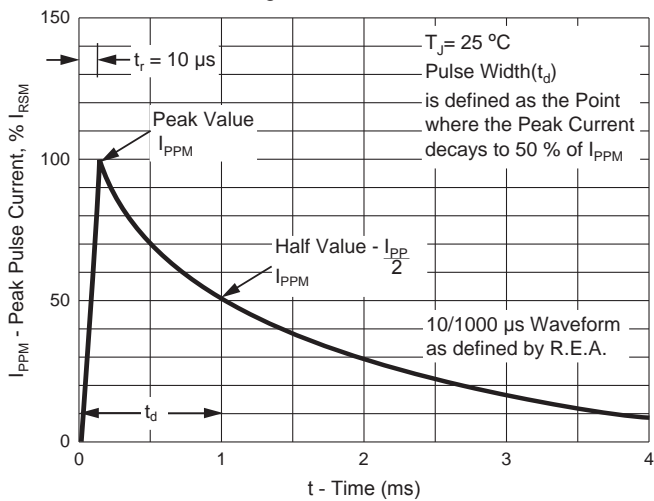
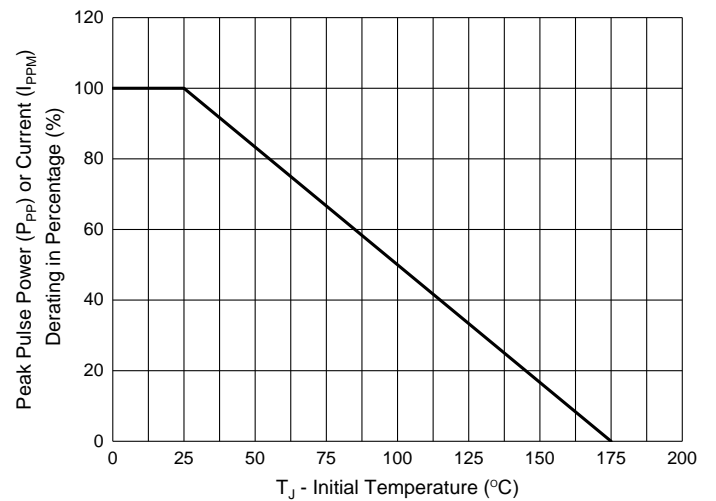

Fig. 4 - Pulse Derating Curve



Ordering Information

Device	Packing
(Part Number)-TP	Tape&Reel: 4Kpcs/Reel
(Part Number)-AP	Ammo Packing: 3Kpcs/Ammo Box
(Part Number)-BP	Bulk:500pcs/Box,25Kpcs/Carton

Note : Adding "-HF" Suffix For Halogen Free, eg. Part Number-TP-HF

IMPORTANT NOTICE

Micro Commercial Components Corp. reserves the right to make changes without further notice to any product herein to make corrections, modifications , enhancements , improvements , or other changes . **Micro Commercial Components Corp .** does not assume any liability arising out of the application or use of any product described herein; neither does it convey any license under its patent rights ,nor the rights of others . The user of products in such applications shall assume all risks of such use and will agree to hold **Micro Commercial Components Corp .** and all the companies whose products are represented on our website, harmless against all damages. **Micro Commercial Components Corp.** products are sold subject to the general terms and conditions of commercial sale, as published at <https://www.mccsemi.com/Home/TermsAndConditions>.

LIFE SUPPORT

MCC's products are not authorized for use as critical components in life support devices or systems without the express written approval of Micro Commercial Components Corporation.

CUSTOMER AWARENESS

Counterfeiting of semiconductor parts is a growing problem in the industry. Micro Commercial Components (MCC) is taking strong measures to protect ourselves and our customers from the proliferation of counterfeit parts. MCC strongly encourages customers to purchase MCC parts either directly from MCC or from Authorized MCC Distributors who are listed by country on our web page cited below. Products customers buy either from MCC directly or from Authorized MCC Distributors are genuine parts, have full traceability, meet MCC's quality standards for handling and storage. **MCC will not provide any warranty coverage or other assistance for parts bought from Unauthorized Sources.** MCC is committed to combat this global problem and encourage our customers to do their part in stopping this practice by buying direct or from authorized distributors.

Looking for pricing, stock, or lifecycle information?

Click below to explore more details on WIN SOURCE:

- [View P6KE200A-AP on WIN SOURCE](#)
- [Micro Commercial Co Information](#)

Optimize Your Supply Chain with WIN SOURCE Solutions

- ✓ Global Sourcing Solution
- ✓ Obsolete Management
- ✓ Cost Control Management
- ✓ Shortage Management
- ✓ Alternative Solution
- ✓ Excess Inventory Management