

LAN Modules

Series/Type: B78477P1*A*14**

The following products presented in this data sheet are being withdrawn.

Ordering Code	Substitute Product	Date of Withdrawal	Deadline Last Orders	Last Shipments
B78477P1007A114		2014-04-25	2014-07-31	2014-10-31
B78477P1006A114		2014-04-25	2014-07-31	2014-10-31
B78477P1005A314		2014-04-25	2014-07-31	2014-10-31

© EPCOS AG 2015. Reproduction, publication and dissemination of this publication, enclosures hereto and the information contained therein without EPCOS' prior express consent is prohibited.

EPCOS AG is a TDK Group Company.



Ordering Code	Substitute Product	Date of Withdrawal	Deadline Last Orders	Last Shipments
B78477P1004A314		2014-04-25	2014-07-31	2014-10-31
B78477P1003A014		2014-04-25	2014-07-31	2014-10-31
B78477P1002A014		2014-04-25	2014-07-31	2014-10-31
B78477P1001A314		2014-04-25	2014-07-31	2014-10-31

For further information please contact your nearest EPCOS sales office, which will also support you in selecting a suitable substitute. The addresses of our worldwide sales network are presented at www.epcos.com/sales.

Applications

- Local Area Networks using Ethernet protocol
- Hubs, switches, routers
- ADSL modems
- Industrial automation equipment using Ethernet protocol for communication

Features

- Fully compliant with IEEE 802.3, IEEE 802.3af (B78477P1001A314)
- With EMI fingers for shielding
- High electrical performance and EMI suppression
- Optimized for all major transceiver ICs
- Industry standard footprint
- RoHS-compatible

Construction

- Housing: Thermoplastic, UL 94 V-0
- Shield: Ni plated on copper alloy
- Contact: Phosphor bronze, 1.27 μm (50 $\mu\text{''}$) Ni underplating, 0.4 μm (15 $\mu\text{''}$) selective gold plating
- Connector dimensions comply with TIA-968 (FCC 68.5) dimension requirements

Marking

- EPCOS, middle block of ordering code, date code

Delivery mode and packing unit

- Blister trays in carton box
- Packing unit: 512 pcs. per carton box (8 trays), B78477P1001A314: 640 pcs.

Overview and ordering codes

Operating temperature range	LED (left - right)	Ordering code
0 °C ... +70 °C	Green - yellow	B78477P1004A314
	Green - yellow	B78477P1005A314
	Yellow - green	B78477P1006A114
	Yellow - green	B78477P1007A114
	–	B78477P1003A014
–40 °C ... +85 °C	Green - yellow	B78477P1001A314
	–	B78477P1002A014

Mechanical characteristics

Insertion force	20 N max.
Retention force	75 N min.
Durability	750 mating cycles min.

LED specification

LED colour	Wave length	Forward voltage	
		Max.	Typical
Green	565 nm	2.6 V	2.2 V
Yellow	585 nm	2.6 V	2.1 V

Characteristics

B78477P1001A314

(electrical specifications at +25 °C)

Turns ratio (primary : secondary)	1.414 : 1 ±3%	
Inductance L	350 μH min.	100 kHz, 100 mV, 8 mA DC bias
Voltage test V_{test} (primary : secondary) (primary : shield)	1500 V_{RMS} 1500 V_{RMS}	0.5 mA, 50 Hz, 1 min ¹⁾ 0.5 mA, 50 Hz, 1 min ¹⁾
DCR (1/2 winding)	0.6 Ω max.	
DCR Balance	±0.065 Ω max.	center tap symmetry
Insertion loss	-1.2 dB max.	0.1 MHz
Return loss	-16 dB min. -10+20log(f/60) dB min. -10 dB min.	0.1 MHz ... 30 MHz 30 MHz ... 60 MHz 60 MHz ... 80 MHz
Crosstalk	-50 dB min. -50+17log(f/10) dB min.	1 MHz 10 MHz ... 100 MHz
Common-mode rejection	-50 dB typ. -15+17log(f/200) dB typ.	2 MHz 30 MHz ... 200 MHz
Weight	Approx. 5.7 g	

 1) On mass manufacture will be 2 s to HV_{test}

Characteristics

B78477P1002A014, B78477P1003A014,
 B78477P1004A314, B78477P1006A114,
 B78477P1007A114

(electrical specifications at +25 °C)

Turns ratio (primary : secondary)	1CT : 1CT ±3%	
Inductance L	350 µH min.	100 kHz, 100 mV, 8 mA DC bias
Voltage test V_{test} (primary : secondary)	1500 V AC	50 Hz, 1 min
Insertion loss	-1.0 dB max.	1 MHz ... 100 MHz
Return loss	-18 dB min. -14 dB min. -12 dB min. -10 dB min.	1 MHz ... 40 MHz 60 MHz 80 MHz 100 MHz
Crosstalk	-33 dB min.	1 MHz ... 100 MHz
Common-mode rejection	-30 dB typ.	1 MHz ... 100 MHz
Weight	Approx. 5.7 g	

Characteristics

B78477P1005A314

(electrical specifications at +25 °C)

Turns ratio (primary : secondary)	1CT : 1 ±3%	
Inductance L	350 µH min.	100 kHz, 100 mV, 8 mA DC bias
Voltage test V_{test} (primary : secondary)	1500 V AC	50 Hz, 1 min
Insertion loss	-1.0 dB max.	1 MHz ... 100 MHz
Return loss	-18 dB min. -14 dB min. -12 dB min. -10 dB min.	1 MHz ... 40 MHz 60 MHz 80 MHz 100 MHz
Crosstalk	-33 dB min.	1 MHz ... 100 MHz
Common-mode rejection	-30 dB typ.	1 MHz ... 100 MHz
Weight	Approx. 5.7 g	

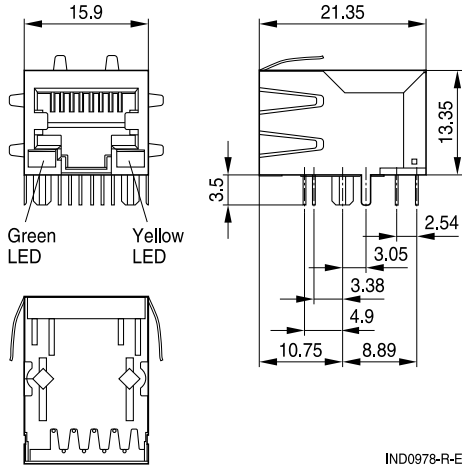
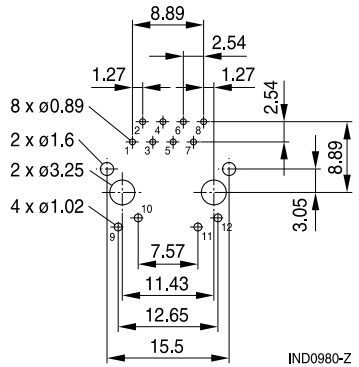
Dimensional drawing for B78477P1001A314

Layout recommendation (top view)

Dimensions in mm

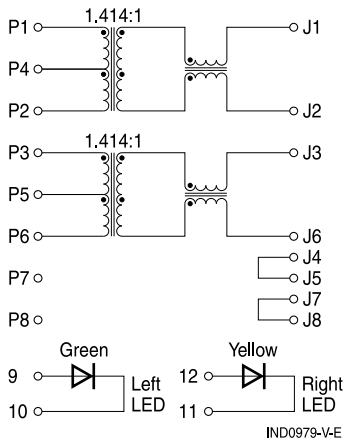
Values without tolerances are nominal values for reference.

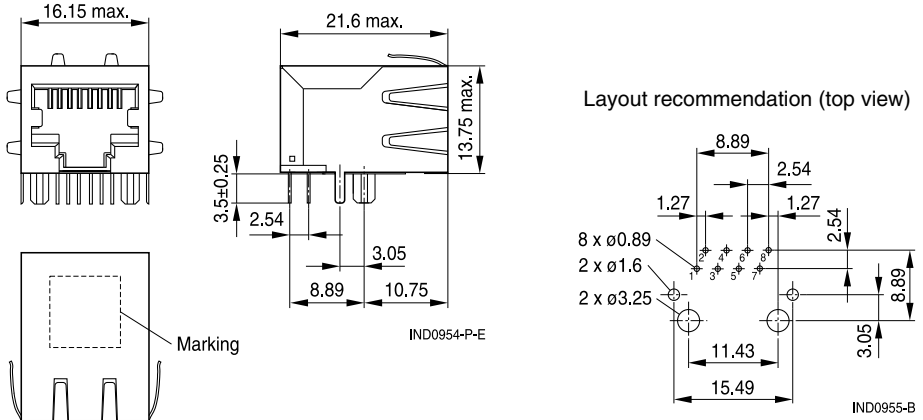
Pinning

Dimensional drawing for B78477P1002A014 and B78477P1003A014

Dimensions in mm

Values without tolerances are nominal values for reference.

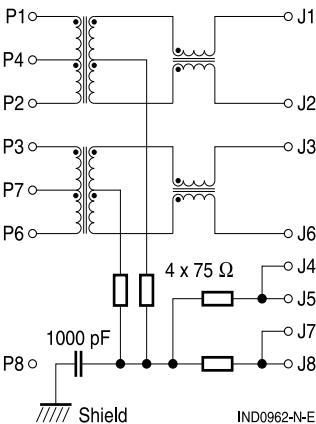
Pinnings
B78477P1002A014

IND0962-N-E

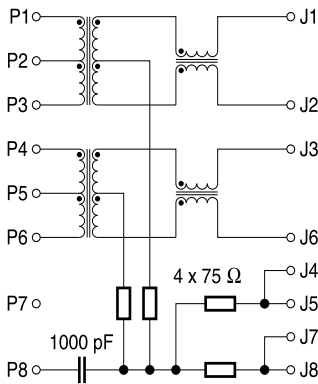
B78477P1003A014

IND0956-R

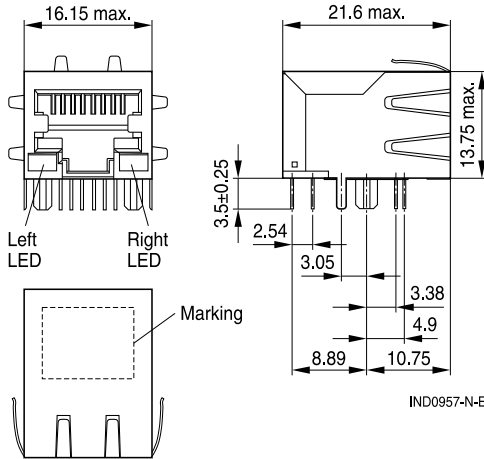
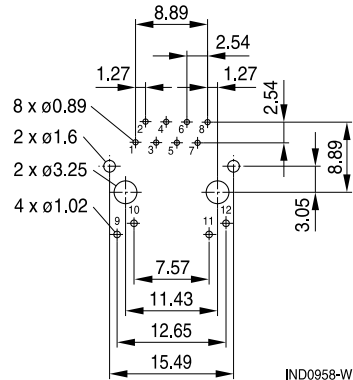
Dimensional drawing for B78477P100A314 and B78477P1005A314

Layout recommendation (top view)

Dimensions in mm

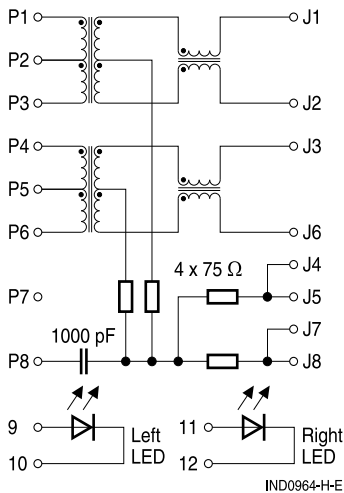
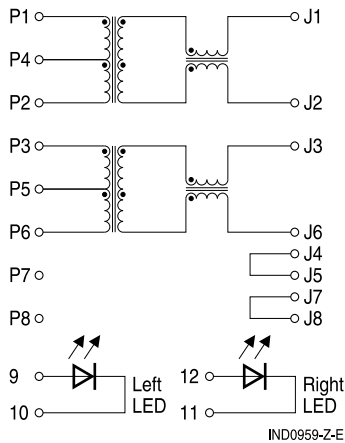
Values without tolerances are nominal values for reference.

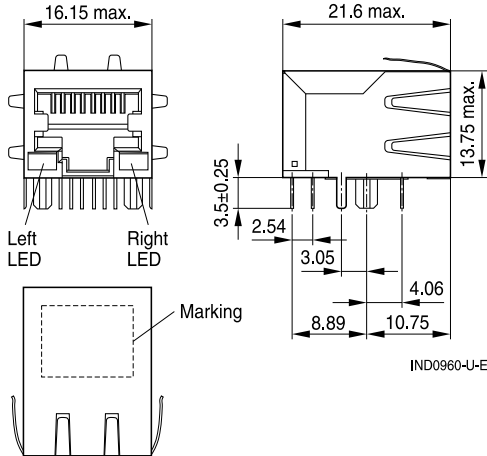
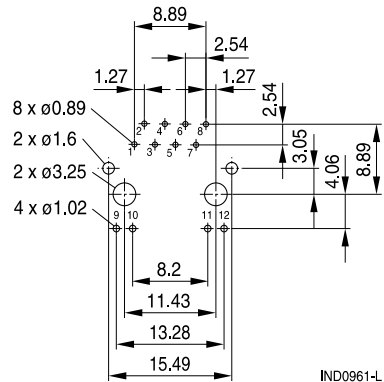
Pinnings
B78477P100A314

B78477P1005A314

Dimensional drawing for B78477P1006A114 and B78477P1007A114

Layout recommendation (top view)

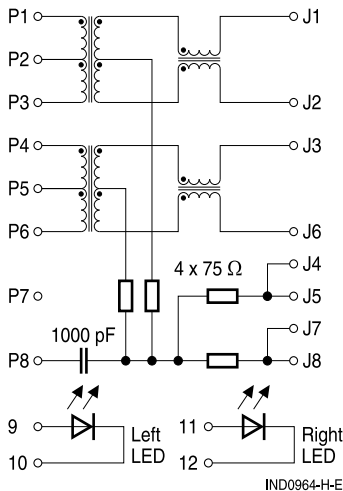
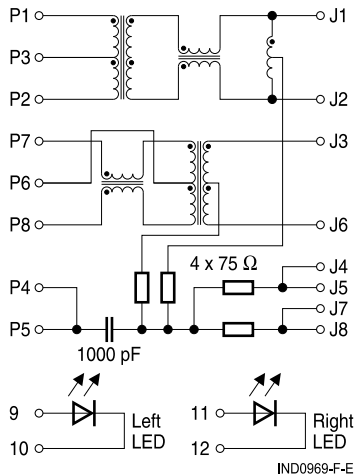
Dimensions in mm

Values without tolerances are nominal values for reference.

Pinnings
B78477P1006A114

B78477P1007A114

Cautions and warnings

- If the components are to be washed varnished it is necessary to check whether the washing varnish agent that is used has a negative effect on the wire insulation, any plastics that are used, or on glued joints. In particular, it is possible for washing varnish agent residues to have a negative effect in the long-term on wire insulation.
- The following points must be observed if the components are potted in customer applications:
 - Many potting materials shrink as they harden. They therefore exert a pressure on the plastic housing or core. This pressure can have a deleterious effect on electrical properties, and in extreme cases can damage the core or plastic housing mechanically.
 - It is necessary to check whether the potting material used attacks or destroys the wire insulation, plastics or glue.
 - The effect of the potting material can change the high-frequency behaviour of the components.
- Ferrites are sensitive to direct impact. This can cause the core material to flake, or lead to breakage of the core.
- Even for customer-specific products, conclusive validation of the component in the circuit can only be carried out by the customer.

Important notes



The following applies to all products named in this publication:

1. Some parts of this publication contain **statements about the suitability of our products for certain areas of application**. These statements are based on our knowledge of typical requirements that are often placed on our products in the areas of application concerned. We nevertheless expressly point out **that such statements cannot be regarded as binding statements about the suitability of our products for a particular customer application**. As a rule we are either unfamiliar with individual customer applications or less familiar with them than the customers themselves. For these reasons, it is always ultimately incumbent on the customer to check and decide whether a product with the properties described in the product specification is suitable for use in a particular customer application.
2. We also point out that **in individual cases, a malfunction of electronic components or failure before the end of their usual service life cannot be completely ruled out in the current state of the art, even if they are operated as specified**. In customer applications requiring a very high level of operational safety and especially in customer applications in which the malfunction or failure of an electronic component could endanger human life or health (e.g. in accident prevention or life-saving systems), it must therefore be ensured by means of suitable design of the customer application or other action taken by the customer (e.g. installation of protective circuitry or redundancy) that no injury or damage is sustained by third parties in the event of malfunction or failure of an electronic component.
3. **The warnings, cautions and product-specific notes must be observed.**
4. In order to satisfy certain technical requirements, **some of the products described in this publication may contain substances subject to restrictions in certain jurisdictions (e.g. because they are classed as hazardous)**. Useful information on this will be found in our Material Data Sheets on the Internet (www.tdk-electronics.tdk.com/material). Should you have any more detailed questions, please contact our sales offices.
5. We constantly strive to improve our products. Consequently, **the products described in this publication may change from time to time**. The same is true of the corresponding product specifications. Please check therefore to what extent product descriptions and specifications contained in this publication are still applicable before or when you place an order.







We also **reserve the right to discontinue production and delivery of products**. Consequently, we cannot guarantee that all products named in this publication will always be available. The aforementioned does not apply in the case of individual agreements deviating from the foregoing for customer-specific products.
6. Unless otherwise agreed in individual contracts, **all orders are subject to our General Terms and Conditions of Supply**.
7. **Our manufacturing sites serving the automotive business apply the IATF 16949 standard**. The IATF certifications confirm our compliance with requirements regarding the quality management system in the automotive industry. Referring to customer requirements and customer specific requirements ("CSR") TDK always has and will continue to have the policy of respecting individual agreements. Even if IATF 16949 may appear to support the acceptance of unilateral requirements, we hereby like to emphasize that **only requirements mutually agreed upon can and will be implemented in our Quality Management System**. For clarification purposes we like to point out that obligations from IATF 16949 shall only become legally binding if individually agreed upon.
8. The trade names EPCOS, CeraCharge, CeraDiode, CeraLink, CeraPad, CeraPlas, CSMP, CTVS, DeltaCap, DigiSiMic, ExoCore, FilterCap, FormFit, LeaXield, MiniBlue, MiniCell, MKD, MKK, MotorCap, PCC, PhaseCap, PhaseCube, PhaseMod, PhiCap, PowerHap, PQSine, PQvar, SIFERRIT, SIFI, SIKOREL, SilverCap, SIMDAD, SiMic, SIMID, SineFormer, SIOV, ThermoFuse, WindCap are **trademarks registered or pending** in Europe and in other countries. Further information will be found on the Internet at www.tdk-electronics.tdk.com/trademarks.

Looking for pricing, stock, or lifecycle information?

Click below to explore more details on WIN SOURCE:

-  [View B7847 on WIN SOURCE](#)
-  [EPCOS \(TDK\) Information](#)

Optimize Your Supply Chain with WIN SOURCE Sol

-  Global Sourcing Solution
-  Obsolete Management
-  Cost Control Management
-  Shortage Management
-  Alternative Solution
-  Excess Inventory Management