



**THE DATASHEET OF
GVA-93+**





FLAT GAIN, ULTRA-WIDEBAND

Monolithic Amplifier

GVA-93+

50Ω 0.01 to 9 GHz

THE BIG DEAL

- Ultra broadband performance
- Excellent Gain Flatness, ± 0.7 dB, 0.05-8 GHz
- Broadband without external matching components
- Suitable for low phase noise applications
- Excellent return loss, 20 dB typ., 2 GHz

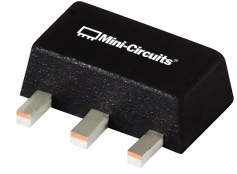

Generic photo used for illustration purposes only

CASE STYLE: DF782

+RoHS Compliant

The +Suffix identifies RoHS Compliance. See our web site for RoHS Compliance methodologies and qualifications

APPLICATIONS

- Base station infrastructure
- Test instruments
- MMDS & Wireless LAN
- LTE
- Satellite communication
- Avionics

PRODUCT OVERVIEW

GVA-93+ (RoHS compliant) is an advanced ultra-wideband amplifier fabricated using GaAs HBT technology and offers excellent gain flatness over a broad frequency range. In addition, the GVA-93+ has good input and output return loss over this frequency range without the need for external matching components. It has repeatable performance from lot to lot and is enclosed in a SOT-89 package for very good thermal performance.

KEY FEATURES

Feature	Advantages
Ultra Broad Band: 0.01 to 9 GHz	Broadband covering primary wireless communications bands: Cellular, PCS, LTE, WiMAX in a single amplifier.
Ultra Flat Gain ± 0.7 dB typ: 0.05 - 8 GHz	Ultra Flat Gain, eliminates need for compensation networks to achieve published results
No External Matching Components Required	GVA-93+ provides good Input and Output Return Loss of 12-28 dB over 0.05 - 6 GHz without the need for any external matching components
Excellent ESD HBM: class 1C (1000 to <2000V) MM: class M2 (100 to <200V)	Simplifies ESD handling.
Low additive phase noise, typically -169 dBc/Hz @10 KHz offset	Ideal for low phase noise synthesizer applications

REV. B
ECO-010563
GVA-93+
TH/RS/CP
111121





ELECTRICAL SPECIFICATIONS AT 25°C AND VCC=5V, R= 16.5Ω UNLESS NOTED

Parameter	Condition (GHz)	Min.	Typ.	Max.	Units
Frequency Range		0.01		9.0	GHz
Gain	0.05	—	16.2	—	dB
	0.85	—	17.2	—	
	2.0	15.2	16.9	18.6	
	6.0	—	16.4	—	
	8.0	—	16.3	—	
	9.0	—	15.2	—	
Gain Flatness	0.05-8		±0.7		dB
Input Return Loss	0.05	—	12.7	—	dB
	0.85	—	24.9	—	
	2.0	16.0	23.8	—	
	6.0	—	22.2	—	
	8.0	—	9.2	—	
	9.0	—	7.1	—	
Output Return Loss	0.05		14.4		dB
	0.85		31.0		
	2.0		23.5		
	6.0		15.5		
	8.0		9.2		
	9.0		7.0		
Reverse Isolation	6.0		20.7		dB
Output Power at 1dB Compression	0.05		15.9		dBm
	0.85		16.3		
	2.0		16.2		
	6.0		13.4		
	8.0		10.3		
	9.0		9.0		
Output IP3	0.2		30.2		dBm
	0.85		31.1		
	2.0		29.9		
	6.0		24.5		
	8.0		21.8		
	9.0		20.3		
Noise Figure	0.2		3.8		dB
	0.85		3.9		
	2.0		4.0		
	6.0		4.4		
	8.0		4.9		
	9.0		5.3		
Additive Phase Noise 2 GHz, 10 KHz offset			-169		dBc/Hz
Supply Operating Voltage (Vcc)		4.8	5.0	5.2	V
Device Operating Current			52	57	mA
Device Current Variation vs. Temperature ²			56		μA/°C
Device Current Variation vs. Voltage			0.020		mA/mW
Thermal Resistance, junction-to-ground lead			156		°C/W

(1) Measured on Mini-Circuits Characterization test board TB-665+. See Characterization Test Circuit (Fig. 1)

(2) (Current at 85°C — Current at -45°C)/130



ABSOLUTE MAXIMUM RATINGS⁽³⁾

Parameter	Ratings
Operating Temperature (ground lead)	-40°C to 85°C
Storage Temperature	-65°C to 150°C
Operating Current at 5V (Vcc) & 16.5Ω resistor	100 mA
Power Dissipation	0.34 W
Input Power (CW)	28 dBm (5 min max.) 11 dBm (continuous)
DC Voltage on Pin 3	6 V

(3) Permanent damage may occur if any of these limits are exceeded.
Electrical maximum ratings are not intended for continuous normal operation.

SIMPLIFIED SCHEMATIC AND PIN DESCRIPTION

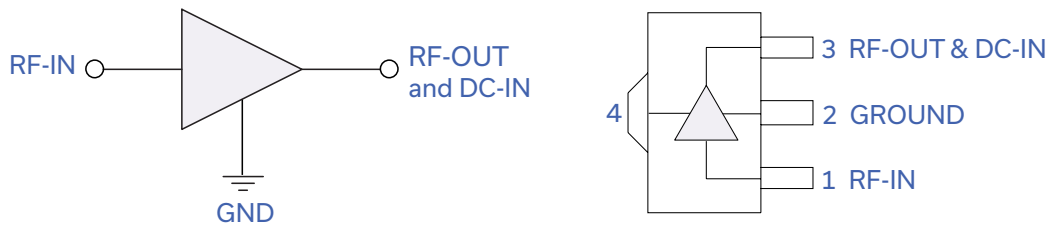

Function	Pin Number	Description
RF IN	1	RF input pin. This pin requires the use of an external DC blocking capacitor chosen for the frequency of operation.
RF-OUT and DC-IN	3	RF output and bias pin. DC voltage is present on this pin; therefore a DC blocking capacitor is necessary for proper operation. An RF choke is needed to feed DC bias without loss of RF signal due to the bias connection, as shown in "Recommended Application Circuit", Fig. 2
GND	2,4	Connections to ground. Use via holes as shown in "Suggested Layout for PCB Design" to reduce ground path inductance for best performance.



CHARACTERIZATION TEST CIRCUIT

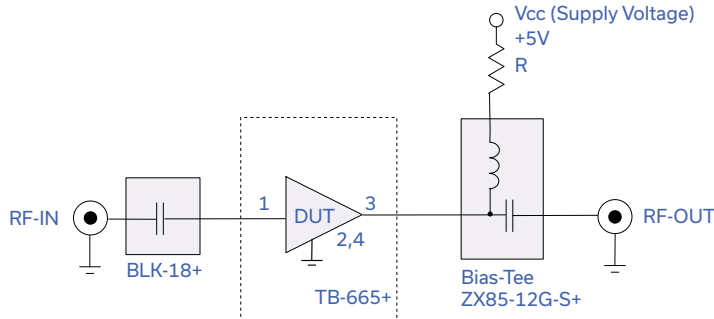

Fig 1. Block Diagram of Test Circuit used for characterization. (DUT soldered on Mini-Circuits Characterization test board TB-665+) Gain, Return loss, Output power at 1dB compression (P1 dB) , output IP3 (OIP3) and noise figure measured using Agilent's N5242A PNA-X microwave network analyzer. (R=16.5Ω)

Conditions:

1. Gain and Return loss: Pin= -25dBm
2. Output IP3 (OIP3): Two tones, spaced 1 MHz apart, 0 dBm/tone at output.

RECOMMENDED APPLICATION CIRCUIT

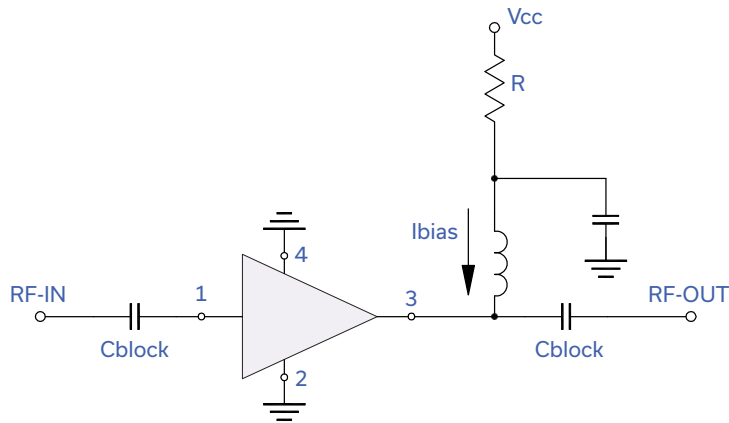
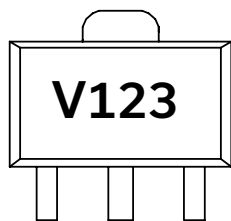

Fig 2. Test Board includes case, connectors, and components soldered to PCB (Cblock=0.001 μF, Cbypass=0.1 μF, R=16.5Ω)

PRODUCT MARKING



Marking may contain other features or characters for internal lot control



Monolithic Amplifier

ADDITIONAL DETAILED TECHNICAL INFORMATION IS AVAILABLE ON OUR DASH BOARD. TO ACCESS [CLICK HERE](#)

Performance Data	Data Table
	Swept Graphs
	S-Parameter (S2P Files) Data Set (.zip file)
Case Style	DF782 (SOT 89) Plastic package, exposed paddle lead finish: Matte-tin
Tape & Reel Standard quantities available on reel	F55 7" reels with 20, 50, 100, 200, 500 or 1K devices
Suggested Layout for PCB Design	PL-370
Evaluation Board	TB-781-1+
Environmental Ratings	ENV08T1

ESD RATING

Human Body Model (HBM): Class 1C (1000 to <2000V) in accordance with ANSI/ESD STM 5.1 - 2001

MSL RATING

Moisture Sensitivity: MSL1 in accordance with IPC/JEDEC J-STD-020D

MSL TEST FLOW CHART

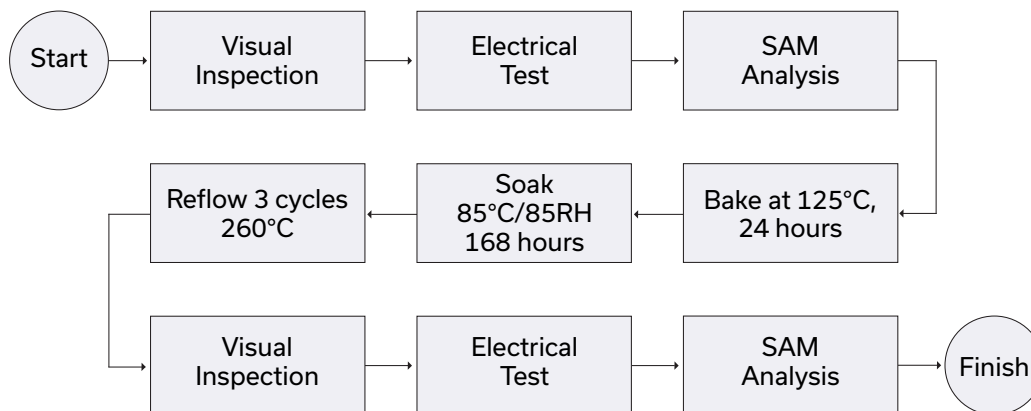

- NOTES**
- A. Performance and quality attributes and conditions not expressly stated in this specification document are intended to be excluded and do not form a part of this specification document.
 - B. Electrical specifications and performance data contained in this specification document are based on Mini-Circuit's applicable established test performance criteria and measurement instructions.
 - C. The parts covered by this specification document are subject to Mini-Circuits standard limited warranty and terms and conditions (collectively, "Standard Terms"); Purchasers of this part are entitled to the rights and benefits contained therein. For a full statement of the standard. Terms and the exclusive rights and remedies thereunder, please visit Mini-Circuits' website at www.minicircuits.com/MCLStore/terms.jsp

Looking for pricing, stock, or lifecycle information?

Click below to explore more details on WIN SOURCE:

 [View GVA-93+](#) on WIN SOURCE

 [Mini-Circuits](#) Information

Optimize Your Supply Chain with WIN SOURCE Solutions

-  Global Sourcing Solution
-  Obsolete Management
-  Cost Control Management
-  Shortage Management
-  Alternative Solution
-  Excess Inventory Management