



**THE DATASHEET OF
DS2182QN**



GENERAL DESCRIPTION

The DS2182A T1 line monitor chip is a monolithic CMOS device designed to monitor real-time performance on T1 lines. The DS2182A frames to the data on the line, counts errors, and supplies detailed information about the status and condition of the line. Large on-board counters allow the accumulation of errors for extended periods, which permits a single CPU to monitor many T1 lines. Output clocks that are synchronized to the incoming data stream are provided for easy extraction of S-bits, FDL bits, signaling bits, and channel data. The DS2182A meets the requirements of ANSI T1.231.

ORDERING INFORMATION

PART	TEMP RANGE	PIN-PACKAGE
DS2182	0°C to +70°C	28 DIP
DS2182N	-40°C to +85°C	28 DIP
DS2182Q	0°C to +70°C	28 PLCC
DS2182QN	-40°C to +85°C	28 PLCC

PIN CONFIGURATION

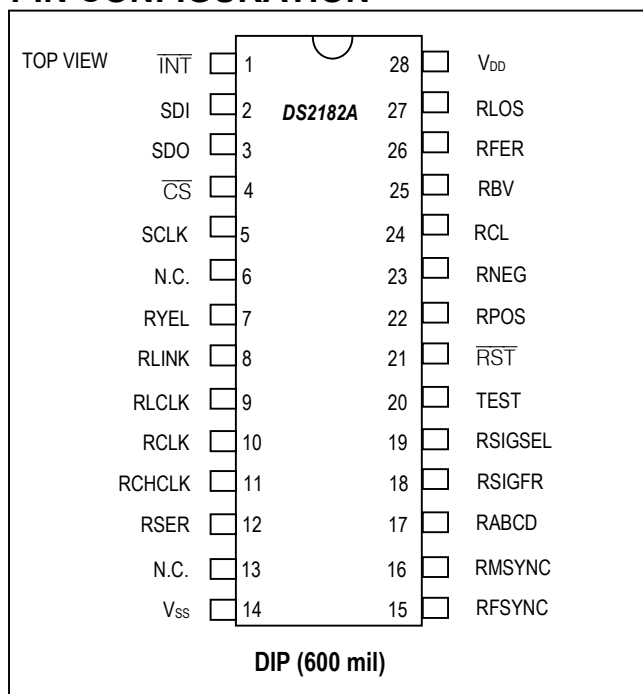

FEATURES

- Performs Framing and Monitoring Functions
- Supports Superframe and Extended Superframe Formats
- Four On-Board Error Counters:
 - 16-Bit Bipolar Violation
 - 8-Bit CRC
 - 8-Bit OOF
 - 8-Bit Frame Bit Error
- Indication of the Following:
 - Yellow and Blue Alarms
 - Incoming B8ZS Codewords
 - 8 and 16 Zero Strings
 - Change-of-Frame Alignment
 - Loss of Sync
 - Carrier Loss
- Simple Serial Interface Used for Configuration, Control, and Status Monitoring
- Burst Mode Allows Quick Access to Counters for Status Updates
- Automatic Counter Reset Feature
- Single 5V Supply; Low-Power CMOS Technology
- Available in 28-Pin DIP and 28-Pin PLCC
- Upward-Compatible from the Original DS2182

The DS2182A includes the following changes from the original DS2182:

- Ability to Count Excessive Zeros
- Severely Errored-Framing-Event Indication
- Updated AIS Detection
- Updated RCL Detection
- AIS and RCL Alarm Clear Indications

Note: Some revisions of this device may incorporate deviations from published specifications known as errata. Multiple revisions of any device may be simultaneously available through various sales channels. For information about device errata, click here: www.maxim-ic.com/errata.

Table 1. Pin Description

PIN	NAME	TYPE	FUNCTION
1	$\overline{\text{INT}}$	O	Receive Alarm Interrupt. Flags host controller during alarm conditions. Active low; open-drain output.
2	SDI	I	Serial Data In. Data for on-board registers. Sampled on rising edge of SCLK.
3	SDO	O	Serial Data Out. Control and status information from on-board registers. Updated on falling edge of SCLK; tri-stated during serial port write or when CS is high.
4	$\overline{\text{CS}}$	I	Chip Select. Must be low to read or write the serial port.
5	SCLK	I	Serial Data Clock. Used to read or write the serial port registers.
6, 13	N.C.	—	No Connect. No internal connection. This pin can be connected to either V_{SS} or V_{DD} , or it can be floated.
7	RYEL	O	Receive Yellow Alarm. Transitions high when a yellow alarm detected; goes low when the alarm clears.
8	RLINK	O	Receive Link Data. Updated with extracted FDL data one RCLK before start of odd frames (193E) and held until next update. Updated with extracted S-bit data one RCLK before start of even frames (193S) and held until next update.
9	RLCLK	O	Receive Link Clock. 4kHz demand clock for RLINK
10	RCLK	I	Receive Clock. 1.544MHz primary clock
11	RCHCLK	O	Receive Channel Clock. 192kHz clock; identifies timeslot (channel) boundaries
12	RSER	O	Receive Serial Data. Received NRZ serial data; updated on rising edges of RCLK
15	RFSYNC	O	Receive Frame Sync. Extracted 8kHz clock, one RCLK wide; F-bit position in each frame
16	RMSYNC	O	Receive Multiframe Sync. Extracted multiframe sync; positive-going edge indicates start of multiframe; 50% duty cycle
17	RABCD	O	Receive ABCD Signaling. Extracted signaling data output; valid for each channel in signaling frames. In non-signaling frames, RABCD outputs the LSB of each channel word.
18	RSIGFR	O	Receive Signaling Frame. High during signaling frames; low during non-signaling frames (and during resync)
19	RSIGSEL	O	Receive Signaling Select. In 193E framing, a .667kHz clock that identifies signaling frames A and C; a 1.33kHz clock in 193S
21	$\overline{\text{RST}}$	I	Reset. A high-low transition clears all internal registers and resets counters. A high-low-high transition initiates a resync.
22	RPOS	I	Receive Bipolar Data Inputs. Sampled on falling of RCLK. Connect together to receive NRZ data and disable bipolar violation monitoring circuitry.
23	RNEG		
24	RCL	O	Receive Carrier Loss. High if 192 consecutive 0's appear at RPOS and RNEG; goes low upon seeing 12.5% 1's density.
25	RBV	O	Receive Bipolar Violation. High during accused bit time at RSER. If bipolar violation detected, low otherwise.
26	RFER	O	Receive Frame Error. High during F-bit time when FT or FS errors occur (193S), or when FPS or CRC errors occur (193E). Low during resync.
27	RLOS	O	Receive Loss-of-Sync. Indicates sync status; high when internal resync is in progress, low otherwise.

Table 2. Power and Test Pin Description

PIN	NAME	TYPE	FUNCTION
14	V _{SS}	—	Signal Ground. 0V
20	TEST	I	Test Mode. Connect to V _{SS} for normal operation.
28	V _{DD}	—	Positive Supply. 5.0V

Table 3. Register Summary

REGISTER	ADDRESS	FUNCTION
BVCR2	0000	Bipolar Violation Count Register 2. LSW of a 16-bit presetable counter that records individual bipolar violations.
BVCR1	0001	Bipolar Violation Count Register 1. MSW of a 16-bit presetable counter that records individual bipolar violations.
CRCCR	0010	CRC Error Count Register. 8-bit presetable counter that records CRC6 errored words in the 193E frame mode.
OOFCR	0011	OOFCR Count Register. 8-bit presetable counter that records OOF events. OOF events are defined by RCR1.5 and RCR1.6.
FEER	0100	Frame Error Count Register. 8-bit presetable counter that records individual bit errors in the framing pattern.
RSR1	0101	Receive Status Register 1. Reports alarm conditions.
RIMR1	0110	Receive Interrupt Mask Register 1. Allows masking of individual alarm-generated interrupts from RSR1.
RSR2	0111	Receive Status Register 2. Reports alarm conditions.
RIMR2	1000	Receive Interrupt Mask Register 2. Allows masking of individual alarm-generated interrupts from RSR2.
RCR1	1001	Receive Control Register 1. Programs device operating characteristics.
RCR2	1010	Receive Control Register 2. Programs device operating characteristics.

Figure 1. Block Diagram

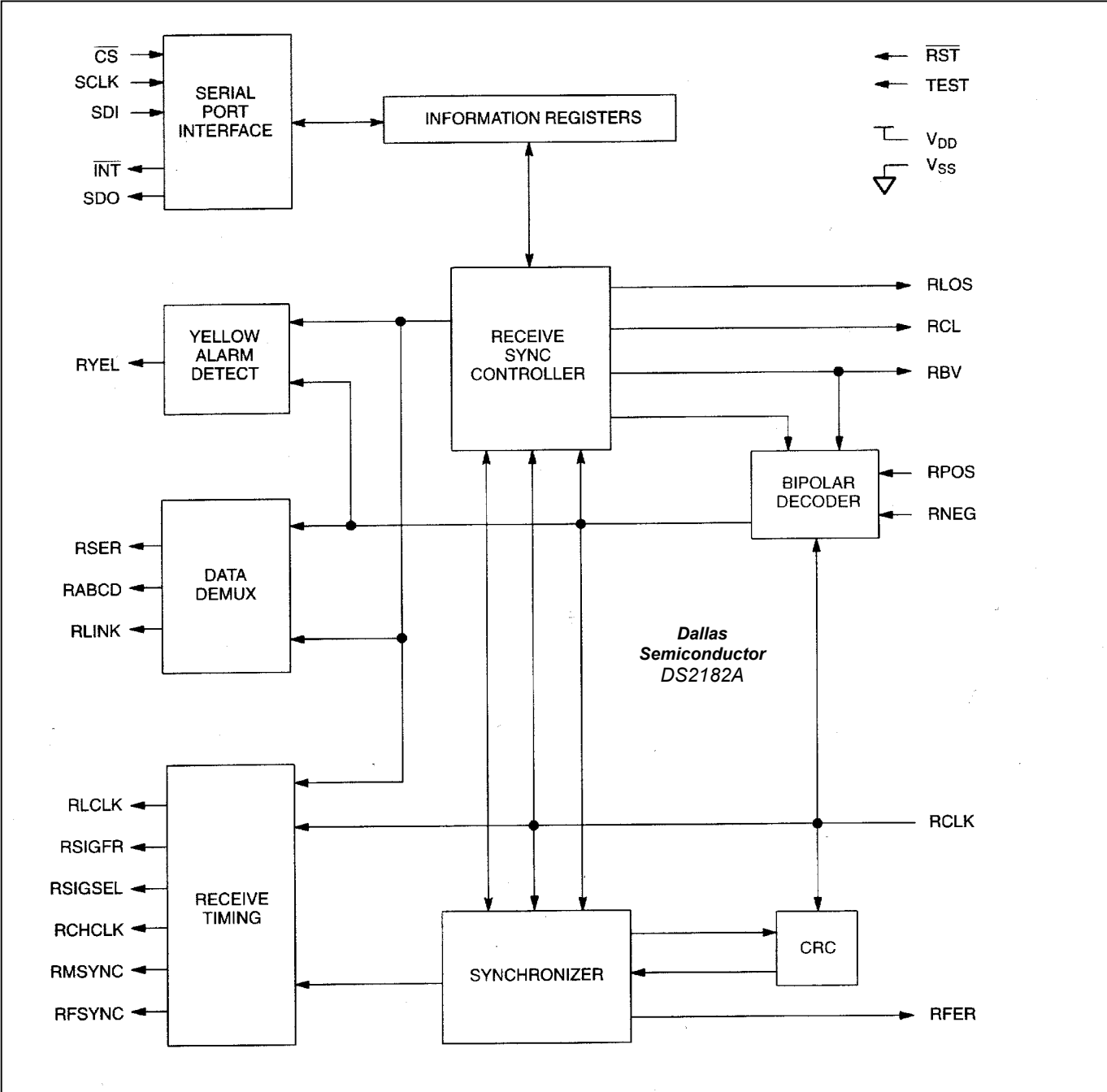

SERIAL PORT INTERFACE

The port pins of the DS2182A serve as a microprocessor/microcontroller-compatible serial port. Eleven on-board registers allow the user to update operational characteristics and monitor device status through a host controller, minimizing hardware interfaces. The port on the DS2182A can be read from or written to at any time. Serial port reads and writes are independent of T1 line timing signals RCLK, RPOS, and RNEG. However, RCLK is needed to clear RSR1 and RSR2 after reads.

ADDRESS/COMMAND

Reading or writing the control, configuration, or status registers requires writing one address/command byte prior to transferring register data. The first bit written (LSB) of the address/command word specifies register read or write. The following four bits identify the register address. The next two bits are reserved and must be set to 0 for proper operation. The last bit of the address/ command word enables burst mode when set. The burst mode causes all registers to be consecutively read or written to. Data is read and written to the DS2182A LSB first.

CHIP SELECT AND CLOCK CONTROL

All data transfers are initiated by driving the \overline{CS} input low. Input data is latched on the rising edge of SCLK and must be valid during the previous low period of SCLK to prevent momentary corruption of register data during writes. Data is output on the falling edge of SCLK and held to the next falling edge. All data transfers are terminated if the \overline{CS} input transitions high. Port control logic is disabled and SDO is tri-stated when \overline{CS} is high.

DATA I/O

Following the eight SCLK cycles that input an address/command byte to write, a data byte is strobed into the addressed register on the rising edge of the next eight SCLK cycles. Following an address/command word to read, contents of the selected register are output on the falling edges of the next eight SCLK cycles. The SDO pin is tri-stated during device write and can be connected to SDI in applications where the host processor has a bidirectional I/O pin.

BURST MODE

The burst mode allows all on-board registers to be consecutively written to or read by the host processor. A burst read is used to poll all registers. RSR1 and RSR2 contents are unaffected. This feature minimizes device initialization time on system power-up or reset. Burst mode is initiated when ACB.7 is set and the address is 0000. A burst is terminated by a low-high transition on \overline{CS} .

ACB: Address Command Byte

MSB

LSB

BM	—	—	ADD3	ADD2	ADD1	ADD0	R/ \overline{W}
----	---	---	------	------	------	------	-------------------

NAME	POSITION	FUNCTION
BM	ACB.7	Burst Mode. If set (and register address is 0000), burst read or write is enabled.
—	ACB.6	Reserved; must be 0 for operation
—	ACB.5	Reserved; must be 0 for operation
ADD3	ACB.4	MSB of register address
ADD0	ACB.1	LSB of register address
R/ \overline{W}	ACB.0	Read/Write Select 0 = write addressed register 1 = read addressed register

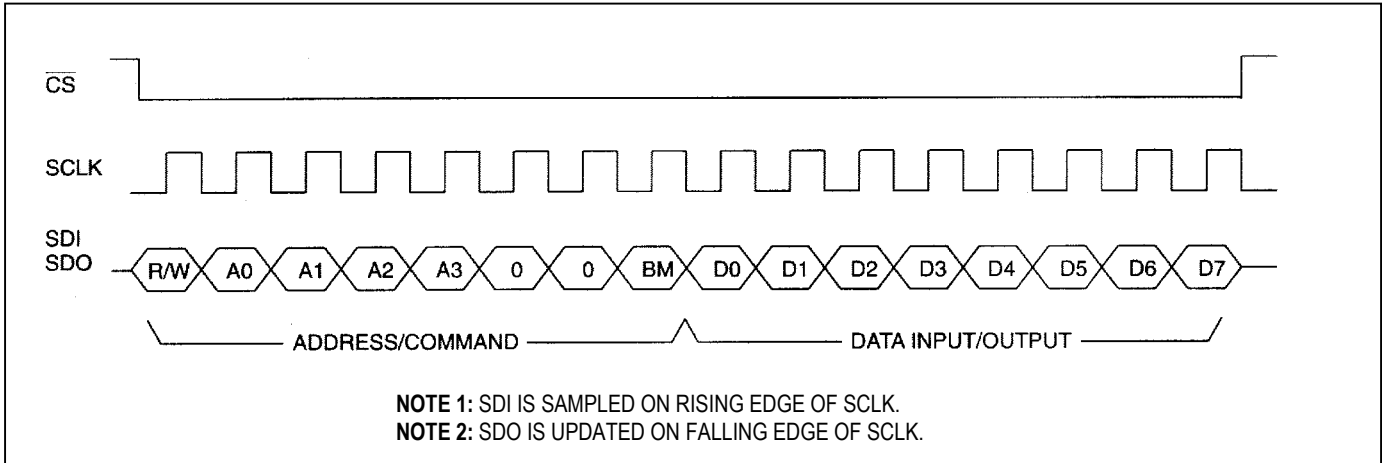
Figure 2. Serial Port Read/Write

OPERATION OF THE COUNTERS

All four of the counters in the DS2182A can be preset by the user to establish an event-count interrupt threshold. The counters count up from the preset value until they reach saturation. At saturation, each additional event occurrence sets the appropriate bit in RSR2 and generates an interrupt if enabled by RIMR2.

The DS2182A contains an auto-counter reset feature in the burst read mode. If RCR1.4 is set, then the user can burst read the four counters (five registers), and all four counters are automatically reset to 0 after the read takes place. Since the burst mode can be terminated at any time by taking \overline{CS} high, the user has the option of reading all of the registers or only the counters. If RCR1.4 is set, then any read of the registers, burst mode or not, clears the count in all four counters. If the user wishes to read the port and not clear the counters, then RCR1.4 must be cleared first.

The counter registers can be read or written to at any time with the serial port, which operates totally asynchronously with the monitoring of the T1 line. Reading a register does not affect the count as long as RCR1.4 is cleared. The dual buffer architecture of the DS2182A ensures that no error events are missed while the serial port is being accessed for reads.

BVCR1: Bipolar Violation Count Register 1; BVCR2: Bipolar Violation Counter Register 2

MSB

LSB

BV7	BV6	BV5	BV4	BV3	BV2	BV1	BV0
-----	-----	-----	-----	-----	-----	-----	-----

NAME	POSITION	FUNCTION
BV7	BVCR.7	MSB of bipolar violation count
BV0	BVCR.0	LSB of bipolar violation count

Bipolar violation count register 1 (BVCR1) is the most significant word and BVCR2 is the least significant word of a presettable 16-bit counter that records individual bipolar violations. If the B8ZS mode is enabled (RCR2.2 = 1), then B8ZS codewords are not counted. The BVCR can also be programmed to count excessive 0's by setting the RCR2.5 bit. In this mode, the BVCR counts occurrences of eight consecutive 0's when B8ZS is enabled or 16 consecutive 0's when B8ZS is disabled. This counter increments at all times and is not disabled by a loss-of-sync condition (RLOS = 1). The counter saturates at 65,535 and generates an interrupt for each occurrence after saturation if RIMR2.0 is set.

Note: To properly preset the bipolar violation count register, BVCR2 must be written to before BVCR1 is written to.

CRCCR: CRC Count Register 2**MSB****LSB**

CRC7	CRC6	CRC5	CRC4	CRC3	CRC2	CRC1	CRC0
------	------	------	------	------	------	------	------

NAME	POSITION	FUNCTION
CRC7	CRCCR.7	MSB of CRC6 word error count
CRC0	CRCCR.0	LSB of CRC6 word error count

The CRC count register (CRCCR) is an 8-bit presettable counter that records word errors in the cyclic redundancy check (CRC). This 8-bit binary counter saturates at 255 and generates an interrupt for each occurrence after saturation if RIMR2.1 is set. The count in this register is only valid in the 193E-framing mode (RCR2.4 = 1), and is reset and disabled in the 193S-framing mode (RCR2.4 = 0). The count is disabled during a loss-of-sync condition (RLOS = 1).

OOF CR: OOF Count Register**MSB****LSB**

OOF7	OOF6	OOF5	OOF4	OOF3	OOF2	OOF1	OOF0
------	------	------	------	------	------	------	------

NAME	POSITION	FUNCTION
OOF7	OOF CR.7	MSB of OOF event count
OOF0	OOF CR.0	LSB of OOF of event count

The OOF count register (OOF CR) is an 8-bit presettable counter that records out-of-frame (OOF) events. OOF events are defined by RCR1.5 and RCR1.6. This 8-bit counter saturates at 255 and generates an interrupt for each occurrence after saturation if RIMR2.2 is set. The count is disabled during a loss-of-sync condition (RLOS = 1).

FE CR: Frame Error Count Register**MSB****LSB**

FE7	FE6	FE5	FE4	FE3	FE2	FE1	FE0
-----	-----	-----	-----	-----	-----	-----	-----

NAME	POSITION	FUNCTION
FE7	FE CR.7	MSB of frame error count
FE0	FE CR.0	LSB of frame error count

The frame error count register (FE CR) is an 8-bit presettable counter that records individual frame-bit errors. In the 193E mode (RCR2.4 = 1), the FE CR records bit errors in the FPS framing pattern (001011). In the 193S mode (RCR2.4 = 0), the FE CR records bit errors in both the FT (101010) and FS (001110) framing patterns if RCR1.3 is set. If RCR1.3 is cleared, then the FE CR only records bit errors in the FT pattern. This 8-bit counter saturates at 255 and generates an interrupt for each occurrence after saturation if RIMR2.3 is set. The count is disabled during a loss-of-sync condition (RLOS = 1).

RSR1: Receive Status Register 1**MSB****LSB**

8ZD	16ZD	RCL	RYEL	RLOS	B8ZSD	RBL	COFA
-----	------	-----	------	------	-------	-----	------

NAME	POSITION	FUNCTION
8ZD	RSR1.7	8 Zero Detect. Set when a string of eight consecutive 0's has been received at RPOS and RNEG.
16ZD	RSR1.6	16 Zero Detect. Set when a string of 16 consecutive 0's has been received at RPOS and RNEG.
RCL	RSR1.5	Receive Carrier Loss. Set when a string of 192 consecutive 0's has been received at RPOS and RNEG. Cleared when 14 or more 1's out of 112 possible bit positions are received.
RYEL	RSR1.4	Receive Yellow Alarm. Set when yellow alarm is detected. The format of yellow alarm is determined by RCR2.3 and RCR2.4.
RLOS	RSR1.3	Receive Loss-of-Sync. Set when resync is in progress.
B8ZSD	RSR1.2	B8ZS Codeword Detect. Set when a B8ZS codeword is received at RPOS and RNEG independent of whether the B8ZS mode is enabled or not (RCR2.2).
RBL	RSR1.1	Receive Blue Alarm. Set when over a 3ms window, five or fewer 0's are received. Cleared when over a 3ms window, six or more 0's are received.
COFA	RSR1.0	Change-of-Frame Alignment. Set when the last resync resulted in a change-of-frame or multiframe alignment.

Note: Alarm 8ZD and 16ZD are cleared on the next occurrence of a 1 at RPOS and RNEG.

RECEIVE STATUS REGISTERS

The receive status registers (RSR1 and RSR2) can be used in either a polled or an interrupt configuration. In a polled configuration, the user reads the RSR at regular intervals to check for alarms. In an interrupt configuration, the user monitors the $\overline{\text{INT}}$ pin. When the $\overline{\text{INT}}$ pin goes low, an alarm condition has occurred and has been reported in one of the RSRs. The processor can then read the RSRs to find which bits have been set. All the bits in the receive status registers operate in a latched fashion. That is, once set, they remain set until read. The bits in the RSR are cleared when read unless the read was performed in the burst mode or the alarm condition still exists.

Yellow Alarm

193S Bit 2

If RCR2.4 = 0 and RCR2.3 = 0, then the DS2182A examines bit 2 of all incoming channels for the presence of a yellow alarm. If bit 2 is set to 0 in 256 consecutive channels, then the reception of a yellow alarm is declared. The alarm is considered cleared when the first channel with bit 2 set to a 1 is received.

193S S-Bit

If RCR2.4 = 0 and RCR2.3 = 1, then the DS2182A examines the S-bit position of frame 12 for the presence of a yellow alarm. The DS2182A declares the presence of a yellow alarm on the first occurrence of the S-bit in frame 12 being set to 1. The alarm is considered cleared when this S-bit returns to 0.

193E FDL

If RCR2.4 = 1, then the DS2182A examines the FDL for a repeating 00FF pattern. If this pattern is received in the FDL 16 consecutive times without error, then a yellow alarm is declared. The alarm is considered cleared as soon as any pattern other than 00FF is received.

RIMR1: Receive Interrupt Mask Register 1**MSB****LSB**

8ZD	16ZD	RCL	RYEL	RLOS	B8ZSD	RBL	COFA
-----	------	-----	------	------	-------	-----	------

NAME	POSITION	FUNCTION
8ZD	RIMR1.7	8 Zero Detect Mask 1 = interrupt enabled 0 = interrupt masked
16ZD	RIMR1.6	16 Zero Detect Mask 1 = interrupt enabled 0 = interrupt masked
RCL	RIMR1.5	Receive Carrier Loss Mask 1 = interrupt enabled 0 = interrupt masked
RYEL	RIMR1.4	Receive Yellow Alarm Mask 1 = interrupt enabled 0 = interrupt masked
RLOS	RIMR1.3	Receive Loss-of-Sync Mask 1 = interrupt enabled 0 = interrupt masked
B8ZSD	RIMR1.2	B8ZS Codeword Detect Mask 1 = interrupt enabled 0 = interrupt masked
RBL	RIMR1.1	Receive Blue Alarm Mask 1 = interrupt enabled 0 = interrupt masked
COFA	RIMR1.0	Change-of-Frame Alignment Mask 1 = interrupt enabled 0 = interrupt masked

RSR2: Receive Status Register 2**MSB****LSB**

SEFE	RCLC	RBLC	FERR	FECS	OOFCS	CRCCS	BPVCS
------	------	------	------	------	-------	-------	-------

NAME	POSITION	FUNCTION
SEFE	RSR2.7	Severely Errored Framing Event. Set when two out of six framing bits (Ft or FPS) are received in error.
RCLC	RSR2.6	Receive Carrier Loss Clear. Set when the carrier signal is restored; remains set until read.
RBLC	RSR2.5	Receive Blue Alarm Clear. Set when the Blue Alarm (AIS) is no longer detected; remains set until read.
FERR	RSR2.4	Frame Bit Error. Set when FT (193S) or FPS (193E) bit errors occur.
FECS	RSR2.3	Frame Error-Count Saturation. Set on the next frame error event after the 8-bit frame error-count register (FECE) saturates at 255.
OOFCS	RSR2.2	Out-of-Frame Count Saturation. Set on the next OOF event after the 8-bit OOF Count Register (OOFCE) saturates at 255.
CRCCS	RSR2.1	CRC Count Saturation. Set on the next CRC error event after the 8-bit CRC Count Register (CRCE) saturates at 255.
BPVCS	RSR2.0	Bipolar Violation Count Saturation. Set on the next BPV error event after the 16-bit Bipolar Violation Count Register (BVCE) saturates at 65,535.

RIMR2: Receive Interrupt Mask Register 2**MSB****LSB**

SEFE	RCLC	RBLC	FERR	FECS	OOFCS	CRCCS	BPVCS
------	------	------	------	------	-------	-------	-------

NAME	POSITION	FUNCTION
SEFE	RIMR2.7	Severely Errored Framing-Event Mask 0 = interrupt masked 1 = interrupt enabled
RCLC	RIMR2.6	Receive Carrier Loss Clear Mask 0 = interrupt masked 1 = interrupt enabled
RBLC	RIMR2.5	Receive Blue Alarm Clear Mask 0 = interrupt masked 1 = interrupt enabled
FERR	RIMR2.4	Frame Bit Error Mask 1 = interrupt enabled 0 = interrupt masked
FECS	RIMR2.3	Frame Error-Count Saturation Mask 1 = interrupt enabled 0 = interrupt masked
OOFCS	RIMR2.2	Out-of-Frame Count Saturation Mask 1 = interrupt enabled 0 = interrupt masked
CRCCS	RIMR2.1	CRC Count Saturation Mask 1 = interrupt enabled 0 = interrupt masked
BPVCS	RIMR2.0	Bipolar Violation Count Saturation Mask 1 = interrupt enabled 0 = interrupt masked

RCR1: Receive Control Register 1**MSB****LSB**

ARC	OOF1	OOF2	ACR	SYNCC	SYNCT	SYNCE	RESYNC
-----	------	------	-----	-------	-------	-------	--------

NAME	POSITION	FUNCTION
ARC	RCR1.7	Auto Resync Criteria 1 = resync on OOF event only 0 = resync on OOF event or Receive Carrier Loss (RCL)
OOF1	RCR1.6	Out-of-Frame 1. OOF event description. Valid when RCR1.5 is cleared. 1 = 2 out of 5 frame bits (FT or FPS) in error 0 = 2 out of 4 frame bits (FT or FPS) in error
OOF2	RCR1.5	Out-of-Frame 2. OOF event description. 1 = 2 out of 6 frame bits (FT or FPS) in error 0 = follow OOF event described in RCR1.6
ACR	RCR1.4	Auto Counter Reset. When set, all four of the counters are reset to 0 when read.
SYNCC	RCR1.3	Sync Criteria. Determines the type of algorithm used by the receive synchronizer; differs for each frame mode. 193S Framing (RCR2.4 = 0) 0 = synchronize to frame boundaries using FT pattern, then search for multiframe by using FS 1 = cross couple FT and FS patterns in sync algorithm 193E Framing (RCR2.4 = 1) 0 = normal sync (uses FPS only) 1 = validate new alignment with CRC before declaring sync
SYNCT	RCR1.2	Sync Time 1 = validate 24 consecutive F-bits before declaring sync 0 = validate 10 consecutive F-bits before declaring sync
SYNCE	RCR1.1	Sync Enable. If clear, the DS2182A automatically begins a resync if the conditions described in RCR1.7 are met. If set, no auto resync occurs.
RESYNC	RCR1.0	Resync. When toggled low to high, the DS2182A initiates a resync immediately. The bit must be cleared and set again for subsequent resyncs.

SYNCHRONIZER

The heart of the monitor is the receive synchronizer. This circuit serves two purposes: it monitors the incoming data stream for loss-of-frame or multiframe alignment, and it searches for a new frame alignment pattern when sync loss is detected. When sync loss is detected, the synchronizer begins an off-line search for the new alignment. All output timing signals remain at the old alignment with the exception of RSIGFR, which is forced low during resync. When one and only one candidate is qualified, the output timing moves to the new alignment at the beginning of the next multiframe. One frame later, RLOS transitions low, indicating valid sync and the resumption of the normal sync-monitoring mode. Several bits in the RCR1 allow tailoring of the resync algorithm by the user. These bits are described below.

Sync Criteria (RCR1.3)

193E

Bit RCR1.3 determines which sync algorithm is used when resync is in progress (RLOS = 1). In 193E framing, when RCR1.3 = 0, the synchronizer locks only to the FPS pattern and moves to the new frame and multiframe alignment after the framing candidate is qualified. RLOS goes low one frame after the move to the new alignment. When RCR1.3 = 1, the new alignment is further tested by a CRC6 code match. RLOS transitions low after a CRC6 match occurs. If no CRC6 match occurs in three attempts (three multiframes), the algorithm resets and a new search for the FPS pattern begins. It takes 9ms for the synchronizer to check the first CRC6 code after the new FPS alignment has been loaded. Each additional CRC6 test takes 3ms. Regardless of the state of RCR1.3, if more than one candidate exists after 24ms, the synchronizer begins eliminating emulators by testing their CRC6 codes in order to find the true framing candidate.

193S

In 193S framing, when RCR1.3 = 1, the synchronizer crosschecks the FT pattern with the FS pattern to help eliminate false-framing candidates such as digital milliwatts. The FS patterns are compared to the repeating pattern ...001111000111000...(001111x0 if RCR2.3 = 1). In this mode, FT and FS must be correctly identified by the synchronizer before sync is declared. Clearing RCR1.3 causes the synchronizer to search for the FT pattern (101010...) without cross-coupling the FS pattern. Frame sync is established using the FT information, while multiframe sync is established only if valid FS information is present. If no valid FS pattern is identified, the synchronizer moves to the FT alignment, RLOS goes low, and a false multiframe position can be indicated by RMSYNC. RFER indicates when the received S-bit pattern does not match the assumed internal multiframe alignment. This mode is used in applications where nonstandard S-bit patterns exist. In such applications, multiframe alignment information can be decoded externally by using the S-bits present at RLINK.

Sync Time (RCR1.2)

Bit RCR1.2 determines the number of consecutive framing pattern bits to be qualified before SYNC is declared. If RCR1.2 = 1, the algorithm validates 24 bits; if RCR1.2 = 0, 10 bits are validated. Validating 24 bits results in superior false-framing protection while 10-bit testing minimizes reframe time. In either case, the synchronizer only establishes resync when one and only one candidate is found (Table 4).

Table 4. Average Reframe Time

FRAME MODE	RCR1.2 = 0			RCR1.2 = 1		
	MIN	AVG	MAX	MIN	AVG	MAX
193S	3.0ms	3.75ms	4.5ms	6.5ms	7.25ms	8.0ms
193E	6.0ms	7.5ms	9.0ms	13.0ms	14.5ms	16.0ms

Note: Average reframe time is defined here as the average time it takes from the start of resync (rising edge of RLOS) to the actual loading of the new alignment (on a multiframe edge) into the output receive timing.

Sync Enable (RCR1.1)

When RCR1.1 is cleared, the receiver initiates automatic resync if an OOF event occurs or if carrier loss (192 consecutive 0's) occurs (depends on RCR1.7). When RCR1.1 is set, the automatic resync circuitry is disabled. In this case, resync can only be initiated by setting RCR1.0 to 1 or externally transitioning \overline{RST} from low to high. Note that using \overline{RST} to initiate a resync resets the output timing while \overline{RST} is low; use of RCR1.1 does not affect the output timing until the new alignment is located.

Resync (RCR1.0)

A 0-to-1 transition of RCR1.0 causes the synchronizer to search for the framing pattern sequence immediately, regardless of the internal sync status. To initiate another resync command, this bit must be cleared and then set again.

RCR2: Receive Control Register 2

MSB

LSB

—	—	BVCRF	FM	SFYEL	B8ZS	—	—
---	---	-------	----	-------	------	---	---

NAME	POSITION	FUNCTION
—	RCR2.7	Reserved ; must be 0 for proper operation
—	RCR2.6	Reserved ; must be 0 for proper operation
BVCRF	RCR2.5	Bipolar Violation Count Register Function Select 0 = do not count excessive 0's 1 = count excessive 0's
FM	RCR2.4	Frame Mode 1 = Extended Superframe (193E, 24 frames per Superframe) 0 = Superframe (193S or D4, 12 frames per Superframe)
SFYEL	RCR2.3	SF Yellow Mode Select 1 = 1 in the S-bit position of frame 12 0 = 0 in bit 2 of all channels
B8ZS	RCR2.2	Bipolar Eight-Zero Substitution 1 = B8ZS enabled 0 = B8ZS disabled
—	RCR2.1	Reserved ; must be 0 for proper operation
—	RCR2.10	Reserved ; must be 0 for proper operation

Figure 3. 193S Receive Multiframe Timing

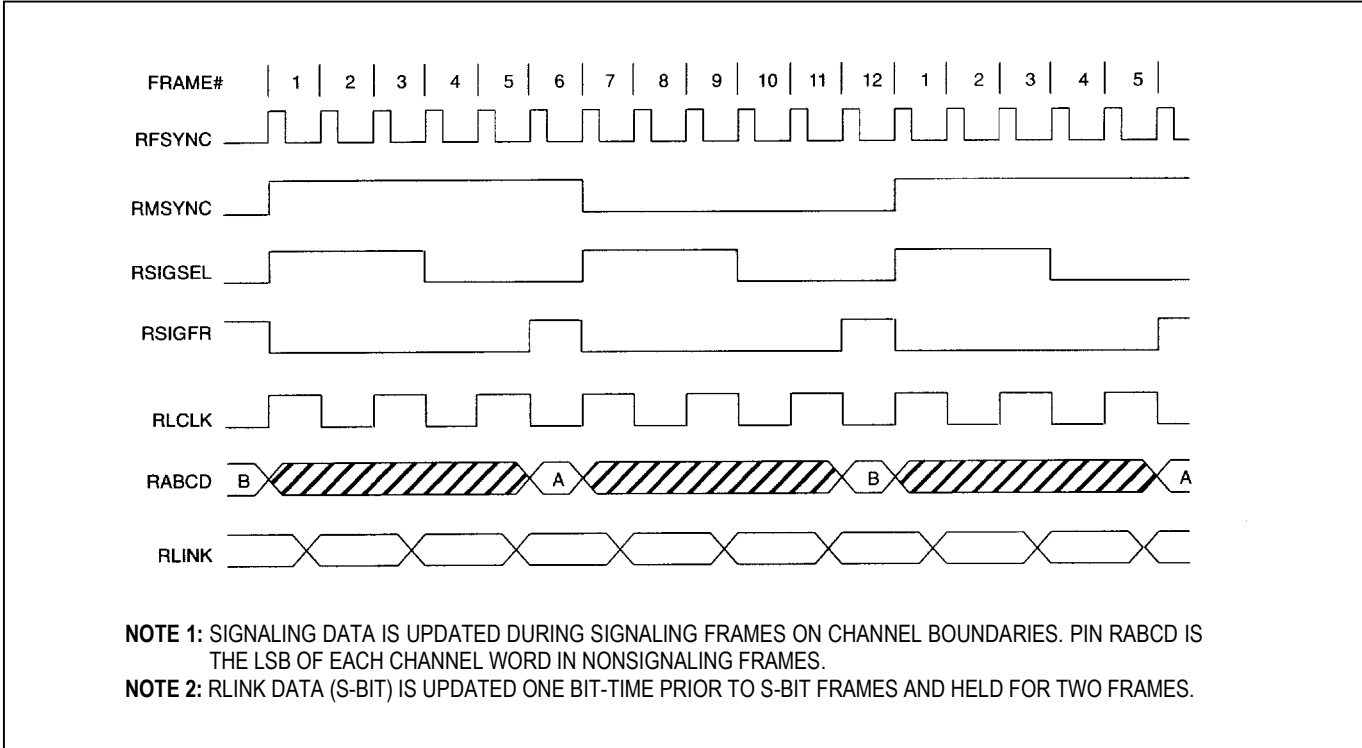

Figure 4. 193E Receive Multiframe Timing

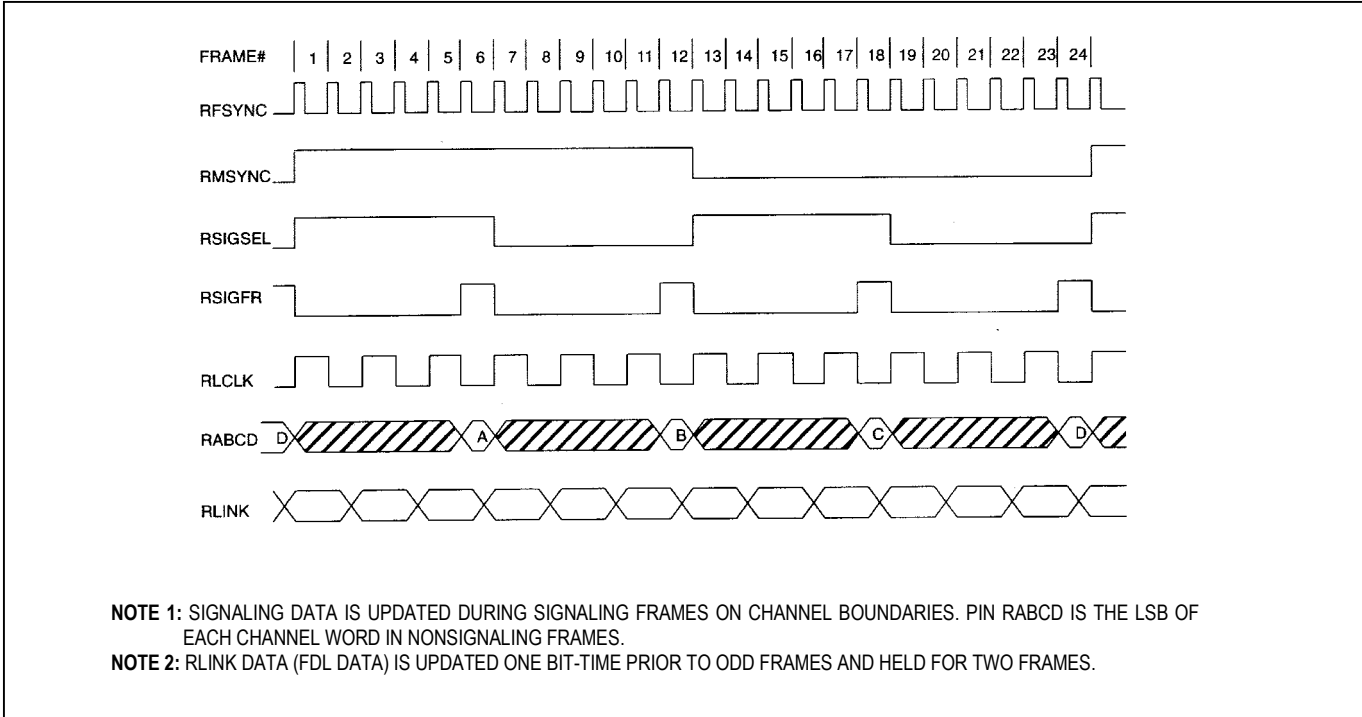
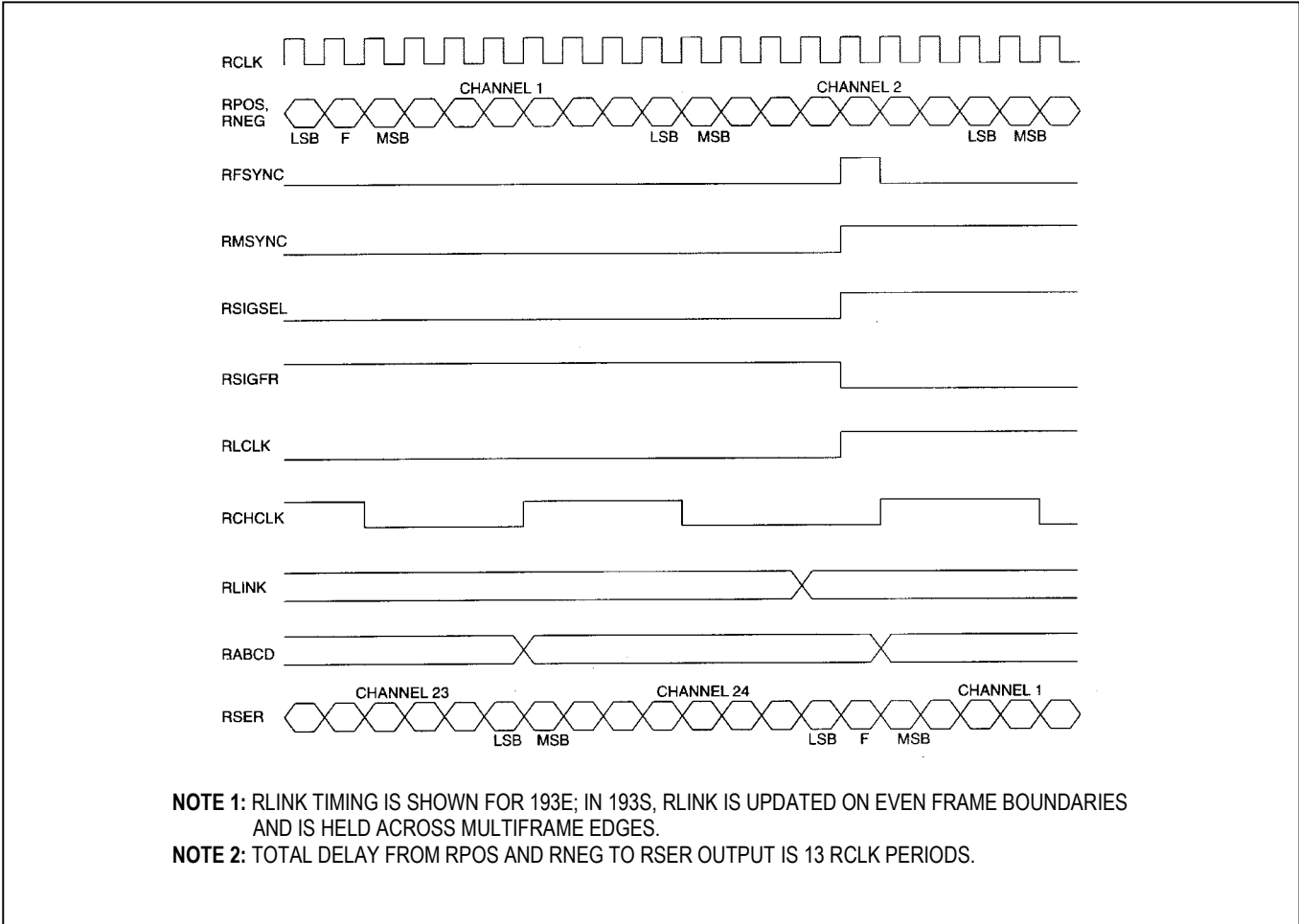

Figure 5. Receive Multiframed Boundary Timing



ALARM OUTPUTS

The transceiver also provides direct alarm outputs for applications when additional decoding and demuxing are required to supplement the on-board alarm logic.

RLOS Output

The receive loss-of-sync output indicates the status of the receiver synchronizer circuitry. When high, an off-line resynchronization is in progress and a high-low transition indicates that resync is complete. The RLOS bit (RSR1.3) is a latched version of the RLOS output. If the auto-resync mode is selected (RCR1.1 = 0), RLOS is a real-time indication of a carrier loss or OOF event occurrence.

RYEL Output

The yellow alarm output transitions high when a yellow alarm is detected. A high-low transition indicates the alarm condition has been cleared. The RYEL bit (RSR1.4) is a latched version of the RYEL output.

RBV Output

The bipolar violation output transitions high when the accused bit emerges at RSER. RBV goes low at the next bit time if no additional violations are detected.

RFER Output

The receive frame-error output transitions high at the F-bit time and is held high for 2-bit periods when a frame bit error occurs. In 193S, framing FT and FS patterns are tested. The FPS pattern is tested in 193E framing. Additionally, in 193E framing, RFER reports CRC6 codeword errors by a low-high-low transition (1-bit period-wide) one-half RCLK period before a low-high transition on RMSYNC ([Figure 6](#)).

Reset ($\overline{\text{RST}}$)

A high-low transition on $\overline{\text{RST}}$ clears all registers and forces an immediate resync when $\overline{\text{RST}}$ returns high. $\overline{\text{RST}}$ must be held low on system power-up to ensure proper initialization of the counters and registers. Following reset, the host processor should restore all control modes by writing appropriate registers with control data.

Figure 6. Alarm Output Timing

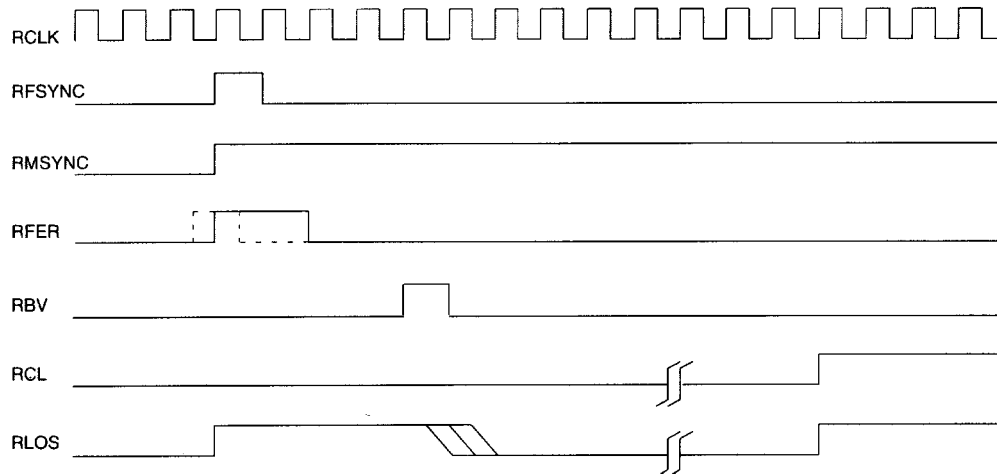

- NOTE 1:** RFER TRANSITIONS HIGH DURING F-BIT TIME IF RECEIVED FRAMING PATTERN BIT IS IN ERROR. (FRAME 12 F-BITS IN 193S ARE IGNORED IF RCR2.3 = 1.) ALSO, IN 193E, RFER TRANSITIONS HIGH ONE-HALF BIT-TIME BEFORE RISING EDGE OF RMSYNC TO INDICATE A CRC6 ERROR FOR THE PREVIOUS MULTIFRAME.
- NOTE 2:** RBV INDICATES RECEIVED BIPOLAR VIOLATION AND TRANSITIONS HIGH WHEN ACCUSED BIT EMERGES FROM RSER. IF B8ZS IS ENABLED, RBV DOES NOT REPORT THE ZERO REPLACEMENT CODE.
- NOTE 3:** RCL TRANSITIONS HIGH WHEN 192 CONSECUTIVE BITS ARE 0; RCL TRANSITIONS LOW UPON RECEPTION OF 12.5% 1'S DENSITY.
- NOTE 4:** RLOS TRANSITIONS HIGH DURING F-BIT TIME THAT CAUSED AN OOF EVENT IF AUTO-RESYNC IS ENABLED (RCR1.1 = 0). RESYNC ALSO OCCURS WHEN LOSS-OF-CARRIER IS DETECTED (RCL = 1) IF RCR1.7 = 0. WHEN RCR1.1 = 1, RLOS REMAINS LOW UNTIL RESYNC OCCURS, REGARDLESS OF OOF OR CARRIER LOSS FLAGS. IN THIS SITUATION, RESYNC IS INITIATED ONLY WHEN RCR1.0 TRANSITIONS LOW-TO-HIGH OR THE $\overline{\text{RST}}$ PIN TRANSITIONS HIGH-LOW-HIGH.

ABSOLUTE MAXIMUM RATINGS

Voltage Range on Any Pin Relative to Ground.....	-0.1V to +7.0V
Operating Temperature Range.....	0°C to +70°C
Storage Temperature Range.....	-55°C to +125°C
Soldering Temperature.....	See IPC/JEDEC J-STD-020A

Stresses beyond those listed under "Absolute Maximum Ratings" may cause permanent damage to the device. These are stress ratings only, and functional operation of the device at these or any other conditions beyond those indicated in the operational sections of the specifications is not implied. Exposure to the absolute maximum rating conditions for extended periods may affect device.

RECOMMENDED DC OPERATING CONDITIONS

($T_A = 0^\circ\text{C}$ to $+70^\circ\text{C}$)

PARAMETER	SYMBOL	MIN	TYP	MAX	UNITS	NOTES
Input Logic 1	V_{IH}	2.0		$V_{CC} + 0.3$	V	1
Input Logic 0	V_{IL}	-0.3		+0.8	V	
Supply	V_{DD}	4.50		5.50	V	

DC ELECTRICAL CHARACTERISTICS

($V_{DD} = 5V \pm 10\%$, $T_A = 0^\circ\text{C}$ to $+70^\circ\text{C}$.)

PARAMETER	SYMBOL	MIN	TYP	MAX	UNITS	NOTES
Supply Current	I_{DD}		3		mA	2, 3
Input Leakage	I_L	-1.0		+1.0	μA	4
Output Current (2.4V)	I_{OH}	-1.0			mA	5
Output Current (0.4V)	I_{OL}	+4.0			mA	6
Output Leakage	I_{LO}	-1.0		+1.0	μA	7

CAPACITANCE

($T_A = +25^\circ\text{C}$)

PARAMETER	SYMBOL	MIN	TYP	MAX	UNITS	NOTES
Input Capacitance	C_{IN}			5	pF	
Output Capacitance	C_{OUT}			7	pF	

Note 1: RCLK, SCLK, and RST $V_{IH(MIN)} = 2.4V$.

Note 2: RCLK = 1.544MHz

Note 3: Outputs open.

Note 4: $0V < V_{IN} < V_{DD}$

Note 5: All outputs except \overline{INT} , which is open-collector.

Note 6: All outputs.

Note 7: Applies to SDO when tri-stated.

CHARACTERISTICS—SERIAL PORT(V_{DD} = 5V ±10%, T_A = 0°C to +70°C.) (Notes 1 and 2) (See [Figure 7](#) and [Figure 8](#))

PARAMETER	SYMBOL	MIN	TYP	MAX	UNITS
SDI to SCLK Setup	t _{DC}	50			ns
SCLK to SDI Hold	t _{CHD}	50			ns
SDI to SCLK Falling Edge	t _{CD}	50			ns
SCLK Low Time	t _{CL}	250			ns
SCLK High Time	t _{CH}	250			ns
SCLK Rise and Fall Times	t _R , t _F			100	ns
$\overline{\text{CS}}$ to SCLK Setup	t _{CC}	50			ns
SCLK to $\overline{\text{CS}}$ Hold	t _{CCH}	50			ns
$\overline{\text{CS}}$ Inactive Time	t _{CWH}	2.5			μs
SCLK to SDO Valid	t _{CDV}			200	ns
$\overline{\text{CS}}$ to SDO High-Z	t _{CDZ}			75	ns

Note 1: Measured at V_{IH} = 2.0 or V_{IL} = 0.8 and 10ns maximum rise and fall time.**Note 2:** Output load capacitance = 100pF.

AC ELECTRICAL CHARACTERISTICS—RECEIVE(V_{DD} = 5.0V ±10%, T_A = 0°C to +70°C) (Notes 1 and 2) (See [Figure 9](#))

PARAMETER	SYMBOL	MIN	TYP	MAX	UNITS
Propagation Delay RCLK to RMSYNC, RFSYNC, RSISEL, RSIGFR, RLCLK, RCHCLK	t _{PRS}			75	ns
Propagation Delay RCLK to RSER, RABCD, RLINK	t _{PRD}			75	ns
Transition Time, All Outputs	t _{TTR}			20	ns
RCLK Period	t _P		648		ns
RCLK Pulse Width	t _R , t _F		324		ns
RCLK Rise and Fall Times	t _{CCH}		20		ns
RPOS, RNEG Setup to RCLK Falling	t _{SRD}	50			ns
RPOS, RNEG Hold to RCLK Falling	t _{HRD}	50			ns
Propagation Delay RCLK to RLOS, RYEL, RBV, RCL, RFER	t _{PRA}			75	ns
Minimum $\overline{\text{RST}}$ Pulse Width	t _{RST}	1			μs

Note 1: Measured at V_{IH} = 2.0 or V_{IL} = 0.8 and 10ns maximum rise and fall time.**Note 2:** Output load capacitance = 100pF.

Figure 7. Serial Port Write AC Timing Diagram

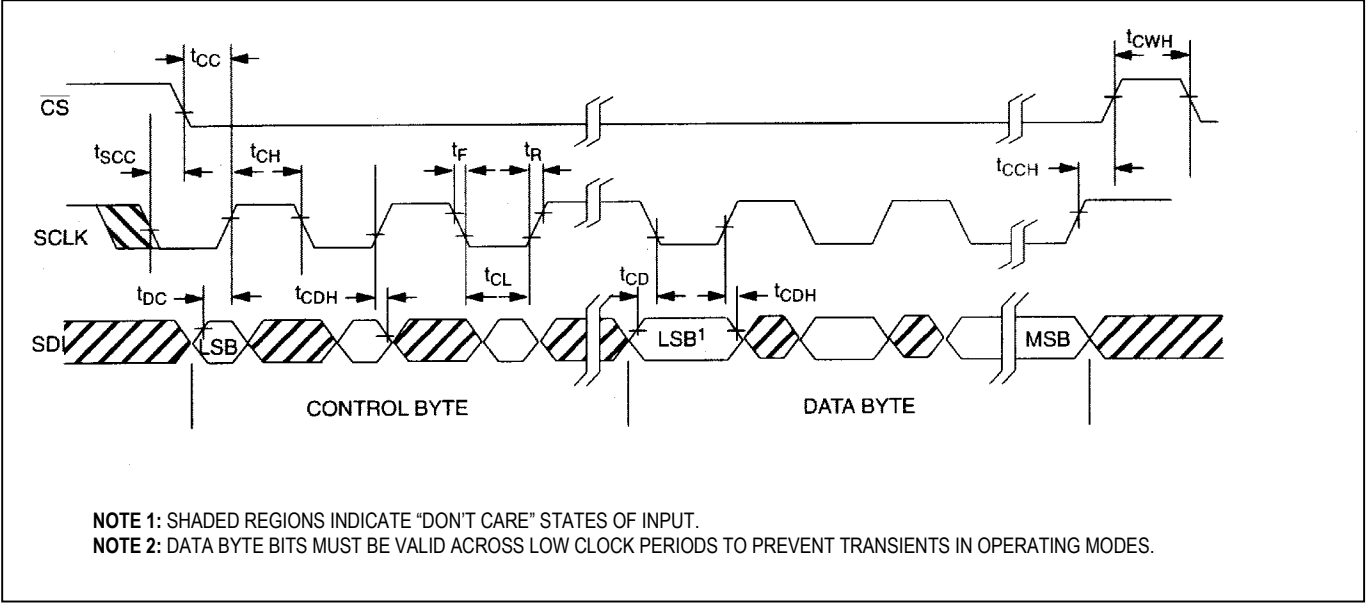

Figure 8. Serial Port Read AC Timing Diagram

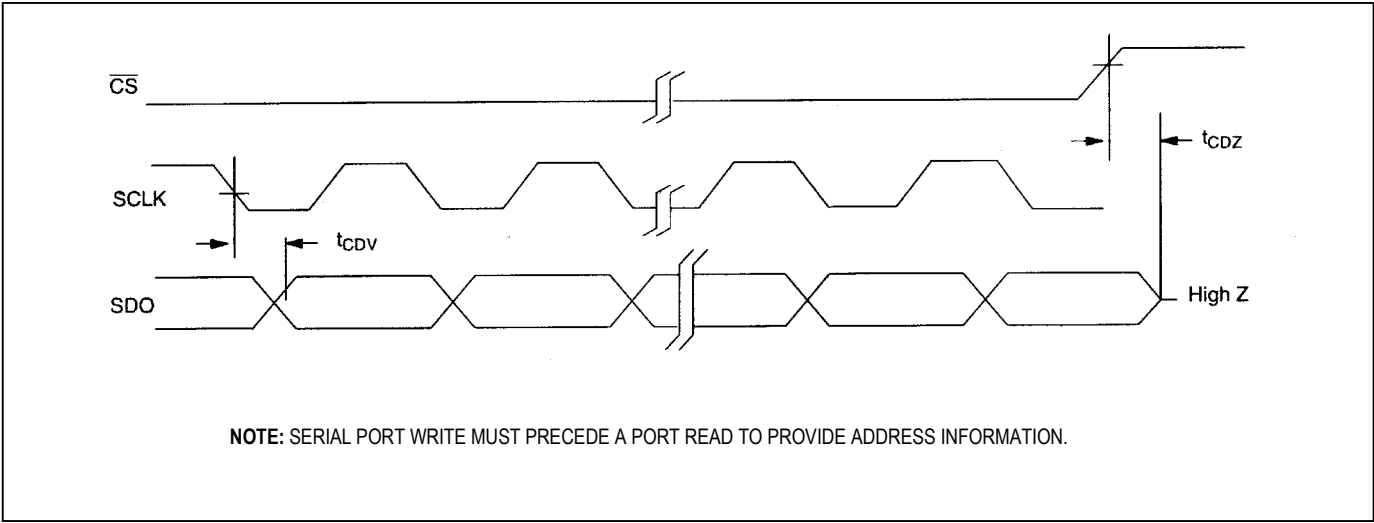
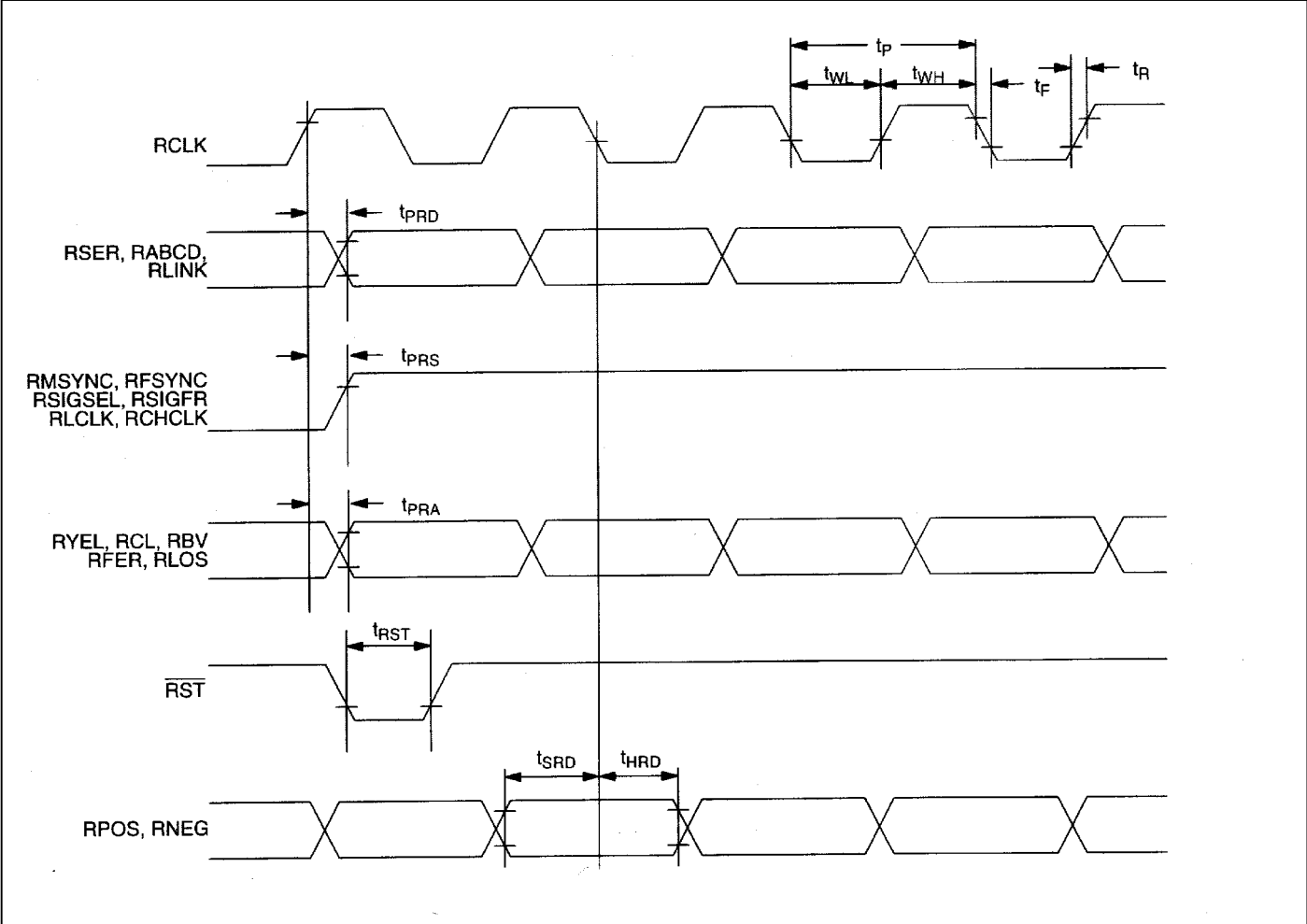

Figure 9. Receive AC Timing Diagram



REVISION HISTORY

DATE	DESCRIPTION
092299	Original release.
080802	Changed typo in <i>Pin Description</i> for ESIGRF to RSIGFR. Added Note 1 to Input Logic 1, V_{IH} spec in the <i>Recommended DC Operating Characteristics</i> table. [Note 1: RCLK, SCLK, and RST $V_{IH(MIN)} = 2.4V$.] Note was added to match the device characterization. No changes were made to fit, form, or function of production units.
120103	Changed ordering information.

PACKAGE INFORMATION

(The package drawing(s) in this data sheet may not reflect the most current specifications. For the latest package outline information, go to www.maxim-ic.com/DallasPackInfo.)

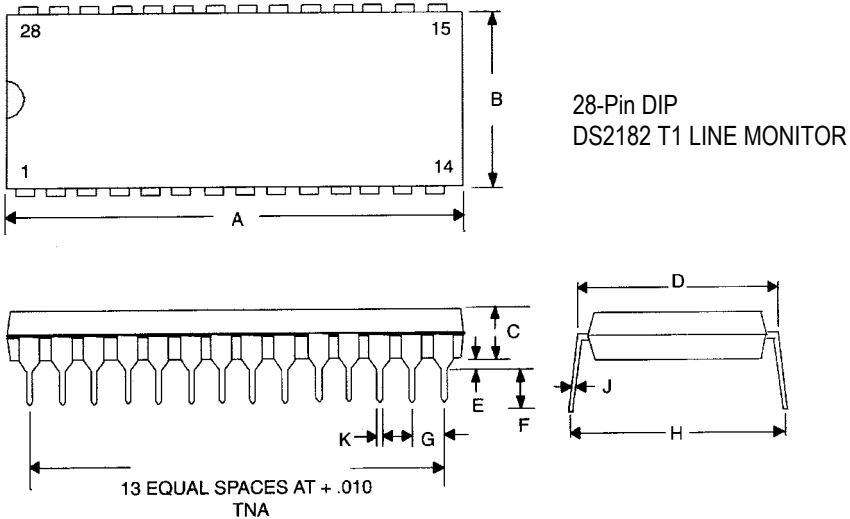

DIM	INCHES	
	MIN	MAX
A	1.445	1.470
B	0.530	0.550
C	0.140	0.160
D	0.600	0.625
E	0.015	0.040
F	0.120	0.145
G	0.090	0.110
H	0.600	0.680
J	0.008	0.012
K	0.015	0.022

PACKAGE INFORMATION (continued)

(The package drawing(s) in this data sheet may not reflect the most current specifications. For the latest package outline information, go to www.maxim-ic.com/DallasPackInfo.)

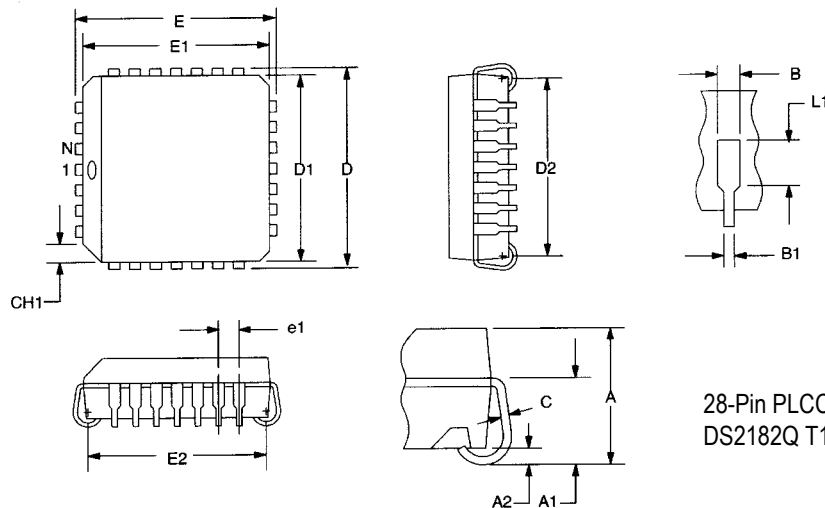

28-Pin PLCC
DS2182Q T1 LINE MONITOR

DIM	INCHES	
	MIN	MAX
A	0.165	0.180
A1	0.090	0.120
A2	0.020	—
B	0.026	0.033
B1	0.013	0.021
C	0.009	0.012
D	0.485	0.495
D1	0.450	0.456
D2	0.390	0.430
E	0.485	0.495
E1	0.450	0.456
E2	0.390	0.430
L1	0.060	—
N	28	—
e1	0.050 BSC	
CH1	0.042	0.048

Maxim/Dallas Semiconductor cannot assume responsibility for use of any circuitry other than circuitry entirely embodied in a Maxim/Dallas Semiconductor product. No circuit patent licenses are implied. Maxim/Dallas Semiconductor reserves the right to change the circuitry and specifications without notice at any time.

Maxim Integrated Products, 120 San Gabriel Drive, Sunnyvale, CA 94086 408-737-7600

© 2003 Maxim Integrated Products • Printed USA

Looking for pricing, stock, or lifecycle information?

Click below to explore more details on WIN SOURCE:

 [View DS2182QN](#) on WIN SOURCE

 [Maxim Integrated](#) Information

Optimize Your Supply Chain with WIN SOURCE Solutions

-  Global Sourcing Solution
-  Obsolete Management
-  Cost Control Management
-  Shortage Management
-  Alternative Solution
-  Excess Inventory Management