



**THE DATASHEET OF
BFCG-162W+**



Ceramic Bandpass Filter

50Ω 950 to 2200 MHz

BFCG-162W+



Generic photo used for illustration purposes only

CASE STYLE: GE0805C-3

Features

- Extremely wide passband, 950-2200 MHz
- Small size 0805(2.0 x 1.25 mm)
- Temperature stable
- LTCC construction

+RoHS Compliant

The +Suffix identifies RoHS Compliance. See our web site for RoHS Compliance methodologies and qualifications

Applications

- Wireless communication
- Harmonic Rejection
- Transmitters / receivers

Electrical Specifications^{1,2} at 25°C

Parameter	F#	Frequency (MHz)	Min.	Typ.	Max.	Unit	
Pass Band	Center Frequency	—	—	1575	—	dB	
	Insertion Loss	F1 - F2	950 - 2200	—	1.8	3.0	dB
	VSWR	F1 - F2	950 - 2200	—	2.0	—	:1
Stop Band, Lower	Insertion Loss	DC - F3	DC - 770	20	25	—	dB
Stop Band, Upper	Insertion Loss	F4 - F5	3000 - 5000	20	30	—	dB

1. Measured on Mini-Circuits Characterization Test Board TB-703+.

2. This filter is not intended for use as a DC Blocking circuit element. In Application where DC voltage is present at either input or output ports, blocking capacitors are required at the corresponding RF port.

Functional Schematic

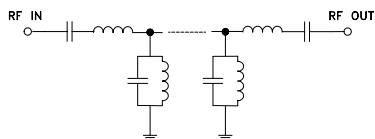

Maximum Ratings

Operating Temperature	-55°C to 125°C
Storage Temperature ³	-55°C to 125°C
RF Power Input ⁴	0.5W at 25°C

3. 12 months max.

4. Passband rating, derate linearly to 0.25W at 100°C ambient. Permanent damage may occur if any of these limits are exceeded.

Typical Frequency Response

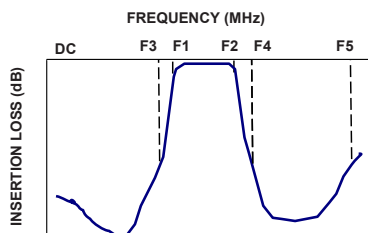

Typical Performance Data at 25°C

Frequency (MHz)	Insertion Loss (dB)	VSWR (:1)
10	53.73	168.77
100	36.66	233.22
500	52.27	29.38
800	27.55	4.05
900	3.72	1.20
1500	0.91	1.20
2200	1.77	1.37
2300	2.55	1.64
2500	9.79	6.26
3000	38.08	42.51
3300	38.31	60.19
3500	40.81	68.65
4000	47.71	72.79
4500	54.61	66.32
5000	37.41	30.84

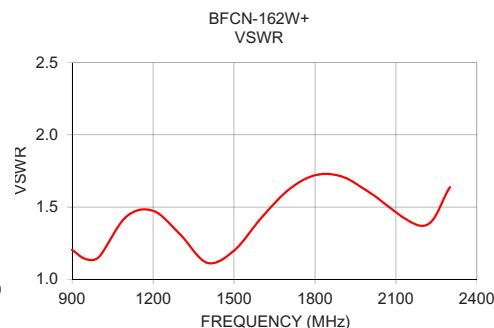
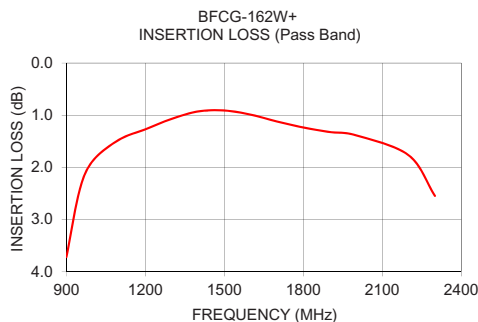
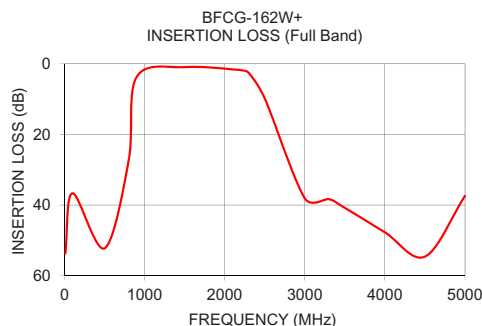

Notes

A. Performance and quality attributes and conditions not expressly stated in this specification document are intended to be excluded and do not form a part of this specification document.

B. Electrical specifications and performance data contained in this specification document are based on Mini-Circuit's applicable established test performance criteria and measurement instructions.

C. The parts covered by this specification document are subject to Mini-Circuits standard limited warranty and terms and conditions (collectively, "Standard Terms"); Purchasers of this part are entitled to the rights and benefits contained therein. For a full statement of the Standard Terms and the exclusive rights and remedies thereunder, please visit Mini-Circuits' website at www.minicircuits.com/MCLStore/terms.jsp



www.minicircuits.com P.O. Box 350166, Brooklyn, NY 11235-0003 (718) 934-4500 sales@minicircuits.com

REV. A
M151107
ED-16419/9
BFCG-162W+
MY/CP/AM
200611

Pad Connections

INPUT	1
OUTPUT	3
GROUND	2,4

Product Marking: N/A

Evaluation Board MCL P/N: TB-703+
Suggested PCB Layout (PL-397)

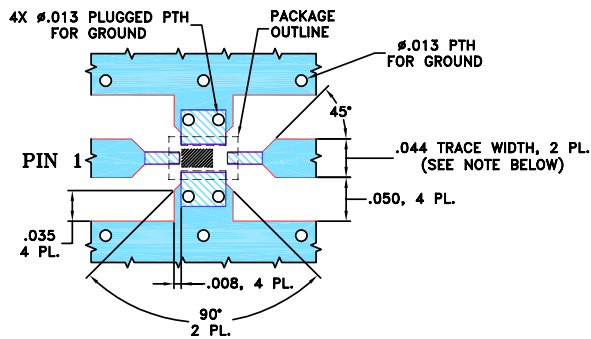

NOTES:

- TRACE WIDTH IS SHOWN FOR ROGERS R04350B WITH DIELECTRIC THICKNESS $.020 \pm .0015$ ". COPPER: 1/2 OZ. EACH SIDE. FOR OTHER MATERIALS TRACE WIDTH AND GAP MAY NEED TO BE MODIFIED.
- BOTTOM SIDE OF THE PCB IS CONTINUOUS GROUND PLANE.

DENOTES PCB COPPER LAYOUT WITH SMOBC (SOLDER MASK OVER BARE COPPER).

DENOTES COPPER LAND PATTERN FREE OF SOLDER MASK.

Outline Drawing

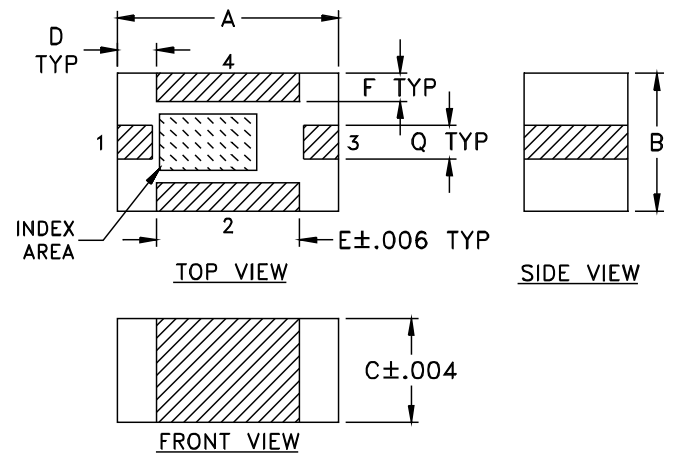

Outline Dimensions (inch/mm)

A	B	C	D	E	F	Q	wt
.079	.049	.037	.014	.051	.010	.012	grams
2.01	1.24	0.94	0.36	1.30	0.25	0.30	.020

Notes

- Performance and quality attributes and conditions not expressly stated in this specification document are intended to be excluded and do not form a part of this specification document.
- Electrical specifications and performance data contained in this specification document are based on Mini-Circuit's applicable established test performance criteria and measurement instructions.
- The parts covered by this specification document are subject to Mini-Circuits' standard limited warranty and terms and conditions (collectively, "Standard Terms"); Purchasers of this part are entitled to the rights and benefits contained therein. For a full statement of the Standard Terms and the exclusive rights and remedies thereunder, please visit Mini-Circuits' website at www.minicircuits.com/MCLStore/terms.jsp

Looking for pricing, stock, or lifecycle information?

Click below to explore more details on WIN SOURCE:

 [View BFCG-162W+](#) on WIN SOURCE

 [Mini-Circuits](#) Information

Optimize Your Supply Chain with WIN SOURCE Solutions

-  Global Sourcing Solution
-  Obsolete Management
-  Cost Control Management
-  Shortage Management
-  Alternative Solution
-  Excess Inventory Management