



**THE DATASHEET OF
AS3701A-BWLM-50**



AS3701

Micro-PMIC

General Description

The AS3701 is a small compact PMU for small size and low power applications.

AS3701 features one 500mA DCDC buck converter operating from 1MHz up to 4MHz, two 200mA LDOs, two 40mA current sinks and offers additional GPIO functions. Further, the device contains an integrated linear battery charger with constant current and constant voltage operation. The wide charging current range going from 11mA up to 500mA and the integrated battery temperature monitoring with selectable NTC beta values make this device suitable for a great variety of applications.

The single supply voltage may vary from 2.7V to 5.5V and all functionalities of AS3701 can be controlled via the I²C interface.

[Ordering Information](#) and [Content Guide](#) appear at end of *datasheet*.

Key Benefits & Features

The benefits and features of AS3701, Micro-PMIC are listed below:

Figure 1:
Added Value of Using AS3701

| Benefits | Features |
|--|--|
| <ul style="list-style-type: none"> Multiple rails in a compact design for low power applications | <ul style="list-style-type: none"> 2 x 200mA universal LDO (1.2V to 3.3V) 500mA Step-down DCDC (0.6125V to 3.35V) 2 programmable current sources up to 40mA Possible external PWM dimming input |
| <ul style="list-style-type: none"> Self-contained Li-Ion battery charger with power path | <ul style="list-style-type: none"> Linear charger with internal transistor 500mA max charging current Trickle-, constant current and constant voltage operation (3.82V to 4.44V) Charger timeout and temperature supervision NTC beta selection |
| <ul style="list-style-type: none"> Flexible multi-purpose IOs for general control tasks and for standalone operation without I²C interface | <ul style="list-style-type: none"> Wake-up / Stand-by / Power-down input PWM input/output Interrupt input/output Low battery and Power Good output Charging and USB current setting input Charger control input/output |

| Benefits | Features |
|---|---|
| <ul style="list-style-type: none"> • Flexible and fast adaptation to different processors/applications | <ul style="list-style-type: none"> • OTP programmable boot sequence |
| <ul style="list-style-type: none"> • Power saving control according to the processor's needs | <ul style="list-style-type: none"> • Stand-by function with programmable voltages |
| <ul style="list-style-type: none"> • Self-contained start-up and safety shutdown feature | <ul style="list-style-type: none"> • I²C control interface • ON-key with 4/8s emergency power-down • POR with Reset I/O |
| <ul style="list-style-type: none"> • Cost effective, small package optimized for PCB cost or size | <ul style="list-style-type: none"> • 17-balls WL-CSP with 0.4mm pitch • 20-balls WL-CSP with 0.4mm pitch |

Applications

The device is a PMU for low power applications like sport watches, smart watches, handheld GPS devices, mobile phones and any other 1-cell Li+ powered devices.

Block Diagram

The functional blocks of this device are shown below:

Figure 2:
Functional Blocks of AS3701A

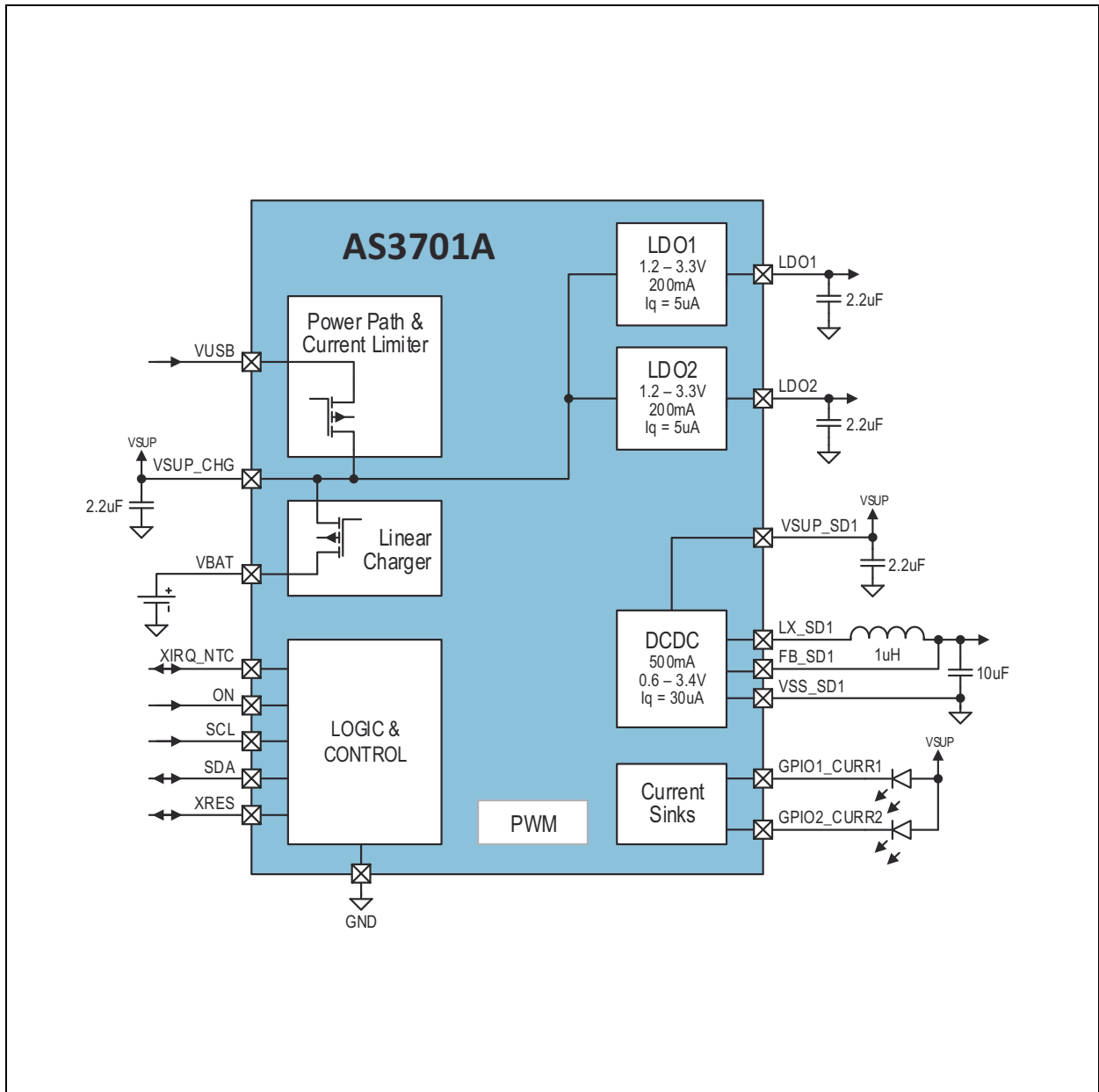

Block Diagram: This figure shows the block diagram of the AS3701A

Figure 3:
Functional Blocks of AS3701B

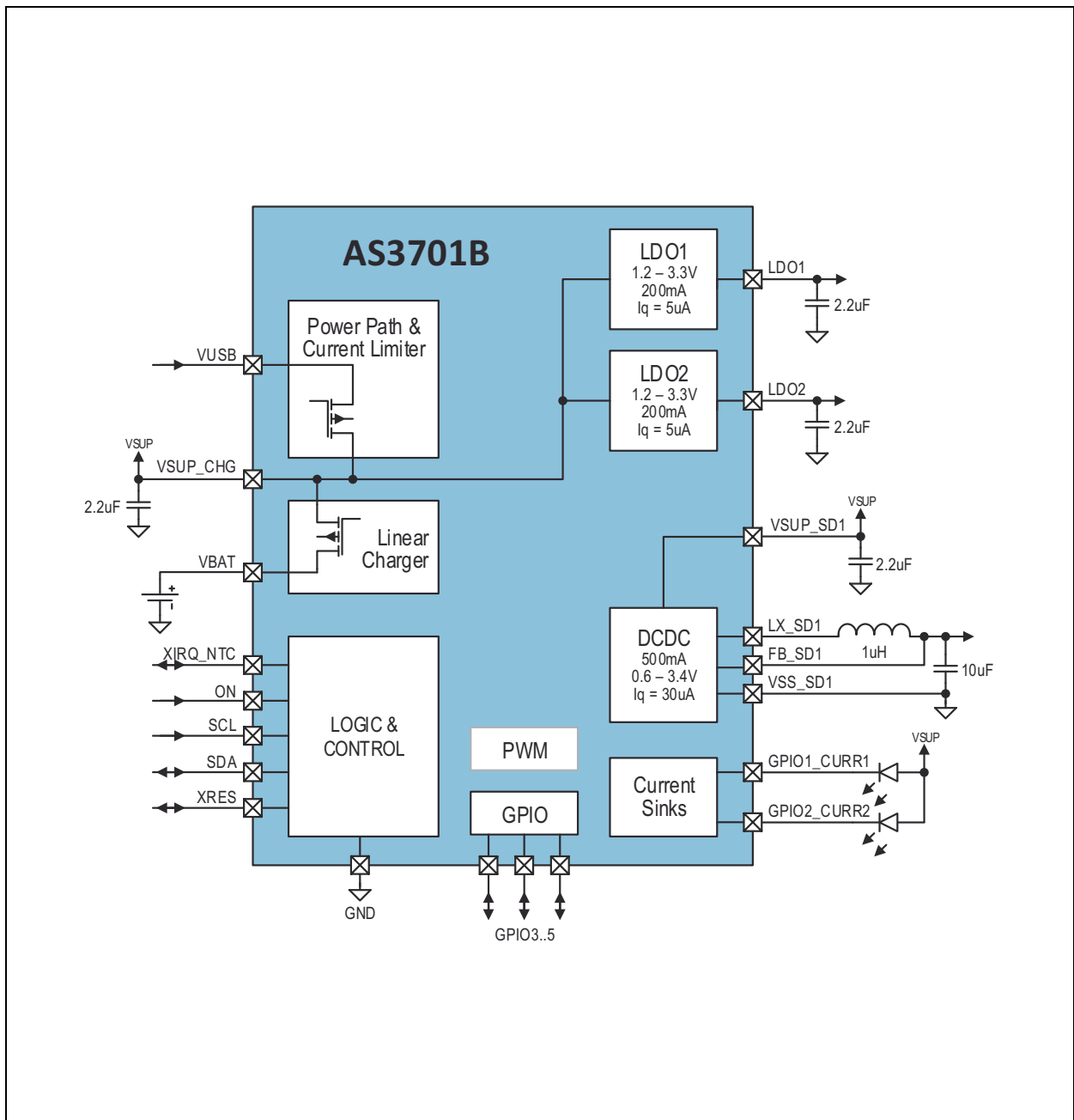

Block Diagram: This figure shows the block diagram of the AS3701B

Pin Assignments

Figure 4:
17-balls WL-CSP Pin Assignment for AS3701A

Pin Assignments: Shows the top view pin assignment of the AS3701A

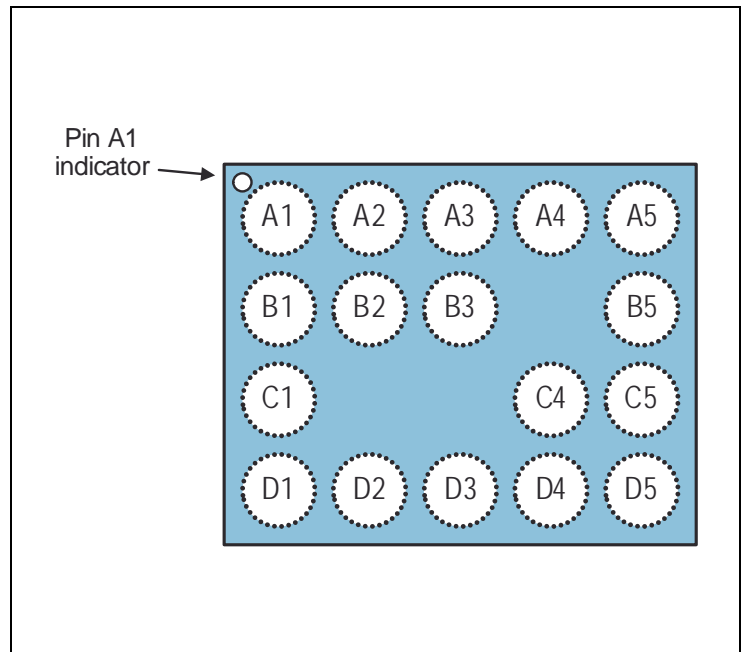

Figure 5:
20-balls WL-CSP Pin Assignment for AS3701B

Pin Assignments: Shows the top view pin assignment of the AS3701B

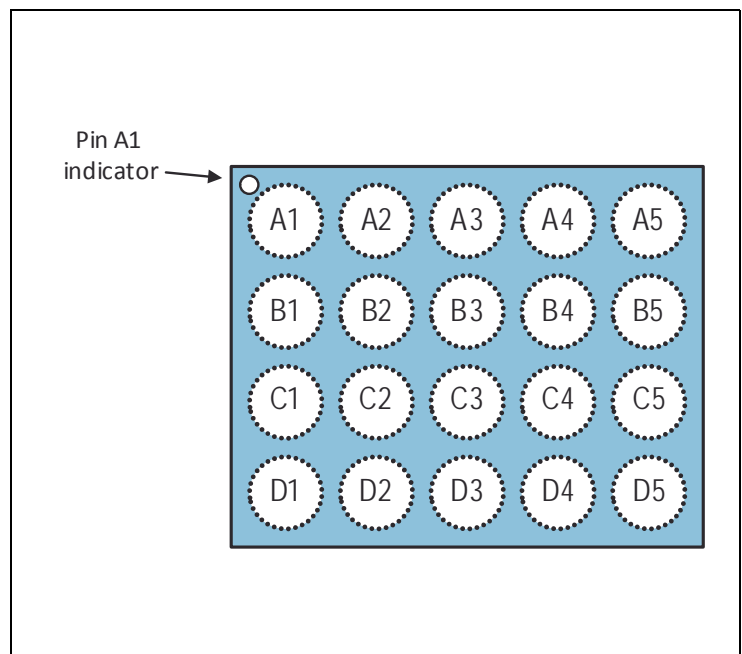

Figure 6:
Pin Description

| Pin Number | | Pin Name | I/O | Description | Max. Voltage | If Not Used |
|------------|----------|-------------|-----|--|--------------|------------------|
| 17 Balls | 20 Balls | | | | | |
| A2 | A2 | VUSB | S | Wall adapter or USB Bus Power input (before protection) | 5.5V | Pull-down to GND |
| A1 | A1 | VSUP_CHG | SIO | Current limiter output, LDO1 & LDO2 pos. supply terminal | VSUP | Mandatory |
| D2 | D2 | VSUP_SD1 | S | DCDC pos. supply terminal | VSUP | Mandatory |
| B1 | B1 | VBAT | S | Li-Ion Battery Terminal | 5.5V | Open |
| A5 | A5 | GND | AIO | Reference GND | - | Mandatory |
| A4 | A4 | LDO1 | AO | LDO1 Output | 3.3V | Open |
| A3 | A3 | LDO2 | AO | LDO2 Output | 3.3V | Open |
| D1 | D1 | LX_SD1 | AIO | DCDC Step Down Switch Output to Coil | 5.5V | Open |
| B2 | B2 | FB_SD1 | AI | DCDC Step Down Feedback Pin | 3.6V | Open |
| D4 | D4 | XRES | DIO | Reset IO | VSUP | Pull-up to VSUP |
| D3 | D3 | ON | DI | Power Up Input | 5.5V | Open |
| B3 | B3 | XIRQ_NTC | AIO | Interrupt Output or NTC Input | VSUP | Open |
| D5 | D5 | SCL | DI | 2-wire Serial IF Clock Input | VSUP | Pull-up to VSUP |
| C4 | C4 | SDA | DIO | 2-wire Serial IF Data I/O | VSUP | Pull-up to VSUP |
| C5 | C5 | GPIO1_CURR1 | DIO | General Purpose IO1 or LED Channel 1 | VSUP | Open |
| B5 | B5 | GPIO2_CURR2 | DIO | General Purpose IO2 or LED Channel 2 | VSUP | Open |
| - | B4 | GPIO3 | DIO | General Purpose IO3 | VSUP | Open |
| - | C2 | GPIO4 | DIO | General Purpose IO4 | VSUP | Open |
| - | C3 | GPIO5 | DIO | General Purpose IO5 | VSUP | Open |
| C1 | C1 | VSS_SD1 | AIO | GND connector of DCDC | - | Mandatory |

Absolute Maximum Ratings

Stresses beyond those listed under [Absolute Maximum Ratings](#) may cause permanent damage to the device. These are stress ratings only. Functional operation of the device at these or any other conditions beyond those indicated under [Electrical Characteristics](#) is not implied. Exposure to absolute maximum rating conditions for extended periods may affect device reliability.

Figure 7:
Absolute Maximum Ratings

| Symbol | Parameter | Min | Max | Units | Comments |
|---|---|------|---------|-------|---|
| Electrical Parameters | | | | | |
| V_{GND} | Supply voltage to ground 5V pins | -0.5 | 7.0 | V | Applicable for pins VSUP_CHG, VSUP_SD1, VBAT, VUSB, LX_SD1, SCL, SDA, ON, XRES, XIRQ_NTC, GPIO3, GPIO4, GPIO5, GPIO1_CURR1, GPIO2_CURR2 |
| V_{GND} | Supply voltage to ground 3V pins | -0.5 | 5.0 | V | Applicable for pins LDO1, LDO2, FB_SD1 |
| | Voltage difference between ground terminals | -0.5 | 0.5 | V | Applicable for pins GND, VSS_SD1 |
| I_{SCR} | Input current (latch-up immunity) | -100 | 100 | mA | JEDEC JESD78 |
| Continuous Power Dissipation ($T_A = 70^\circ\text{C}$) | | | | | |
| P_T | Continuous power dissipation | | 0.96 | W | $P_T^{(1)}$ for WL-CSP20 ($R_{THJA} \sim 57\text{K/W}$) |
| Electrostatic Discharge | | | | | |
| ESD_{HBM} | Electrostatic discharge (human body model) | | ± 2 | kV | JEDEC JESD22-A114F |

| Symbol | Parameter | Min | Max | Units | Comments |
|--|--|-----|-----|-------|---|
| Temperature Ranges and Storage Conditions | | | | | |
| T_A | Operating temperature | -40 | 85 | °C | |
| R_{THJA} | Junction to ambient thermal resistance | | | °C/W | R_{THJA} typ. 57K/W |
| T_J | Junction temperature | | 125 | °C | |
| T_{STRG} | Storage temperature range | -55 | 125 | °C | |
| T_{BODY} | Package body temperature | | 260 | °C | IPC/JEDEC J-STD-020 ⁽²⁾ |
| RH_{NC} | Relative humidity (non-condensing) | 5 | 85 | % | |
| MSL | Moisture sensitivity level | 1 | | | Represents an unlimited floor life time |

Note(s):

1. Depending on actual PCB layout and PCB used
2. The reflow peak soldering temperature (body temperature) is specified according IPC/JEDEC J-STD-020 "Moisture/Reflow Sensitivity Classification for Non hermetic Solid State Surface Mount Devices"

Electrical Characteristics

All limits are guaranteed. The parameters with min and max values are guaranteed with production tests or SQC (Statistical Quality Control) methods.

Figure 8:
Electrical Characteristics

| Symbol | Parameter | Conditions | Min | Typ | Max | Unit |
|-------------------|-------------------------------|---|-----|------|-----|---------|
| V_{IN} | Input voltage range | Pin VSUP | 2.7 | | 5.5 | V |
| I_{Q_ACTIVE} | Active mode quiescent current | Normal operating current | | 26 | | μA |
| $I_{Q_STAND-BY}$ | Stand-by quiescent current | Normal operating current (Oscillator ON) | | 26 | | |
| | | Normal operating current (Oscillator OFF) | | 11.5 | | |
| $I_{POWEROFF}$ | Shutdown current | $power_off = 1$ | | 1.2 | | |

Electrical Characteristics: $V_{SUP} = 3.7V$, $V_{OUT} < V_{IN} - 0.5V$, $T_{AMB} = -40^{\circ}C$ to $85^{\circ}C$, typ. values @ $T_{AMB} = 25^{\circ}C$ (unless otherwise specified)

Detailed Description – Power Management Functions

Step Down Converter

The step-down converter is a high-efficiency fixed frequency current mode regulator. By using low resistance internal PMOS and NMOS switches, efficiency up to 95% can be achieved. The fast switching frequency allows using small inductors, without increasing the current ripple. The unique feedback and regulation circuit guarantees optimum load and line regulation over the whole output voltage range, up to the maximum output current, with an output capacitor of only 10µF. The implemented current limitation protects the DCDC Converter and the coil during overload condition.

Figure 9:
DCDC Step-Down Converter Block Diagram

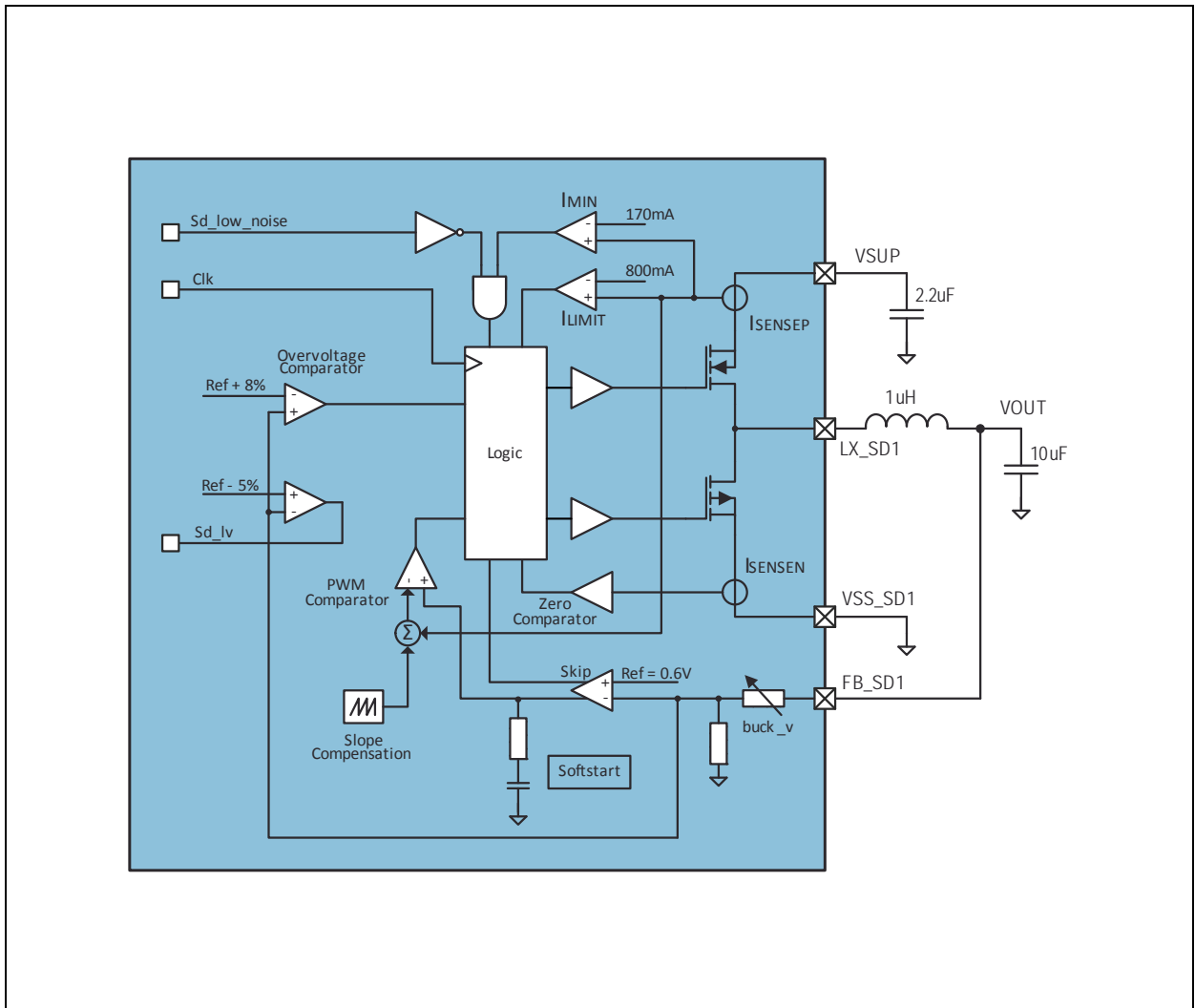

Mode Settings

To allow optimized performance in different applications, there are bit settings possible, to get the best compromise between high efficiency and low input/output ripple.

Figure 10:
DCDC Step-Down Converter Mode Settings

Mode Setting: This graph shows the difference of the efficiency curves for high efficiency and low noise mode setting. $V_{SUP} = 3.7V$, $V_{OUT} = 2.5V$, $f_{SW} = 3MHz$, $T_{AMB} = 25^{\circ}C$.

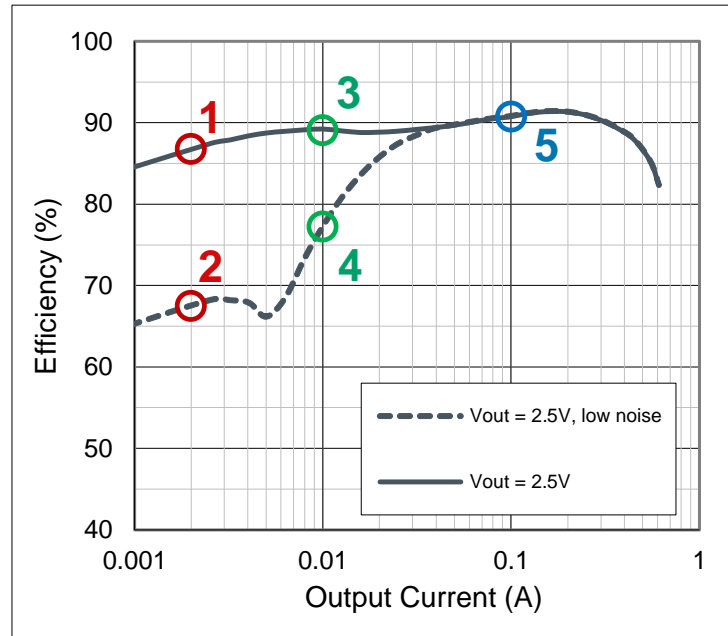

Low-Ripple, Low-Noise Operation

Low-ripple, low-noise operation can be enabled by setting the bit *sd_low_noise [SD_control1]* to 1.

In this mode there is no minimum coil current necessary before switching OFF the PMOS. As long as the load current is superior to the ripple current, the device operates in continuous mode. When the load current gets lower, the discontinuous mode is triggered. Resultant the auto-zero comparator stops the NMOS conduction to avoid load discharger and the duty cycle is reduced down to t_{MIN_ON} to keep the regulation loop stable. This results in a very low ripple and noise, but decreased efficiency at light loads, especially at low input to output voltage differences.

Figure 11:
Switching Behavior at Operating Point 4

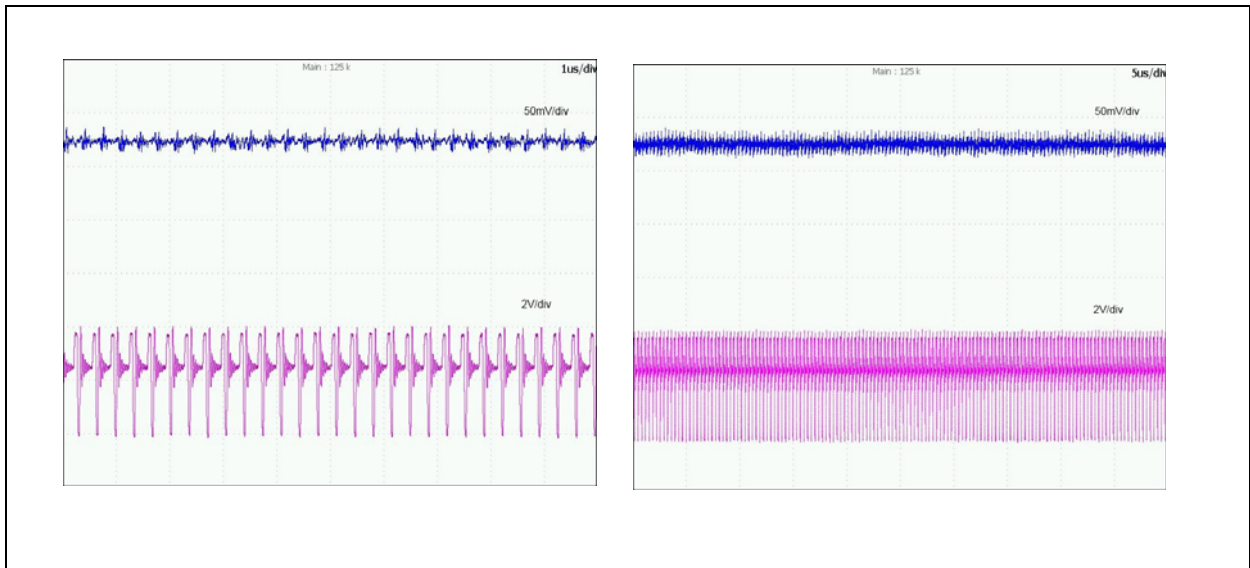

Operating Point 4: These graphs show the switching behavior referring to the operating point 4 from figure 10. Here the mode is set to low noise/low ripple operation and the DCDC is continuously switching at 10mA load current.

Only in the case the load current gets so small, that less than the minimum on time of the PMOS would be needed to keep the loop in regulation, the regulator will enter low power mode operation.

Figure 12:
Switching Behavior at Operating Point 2

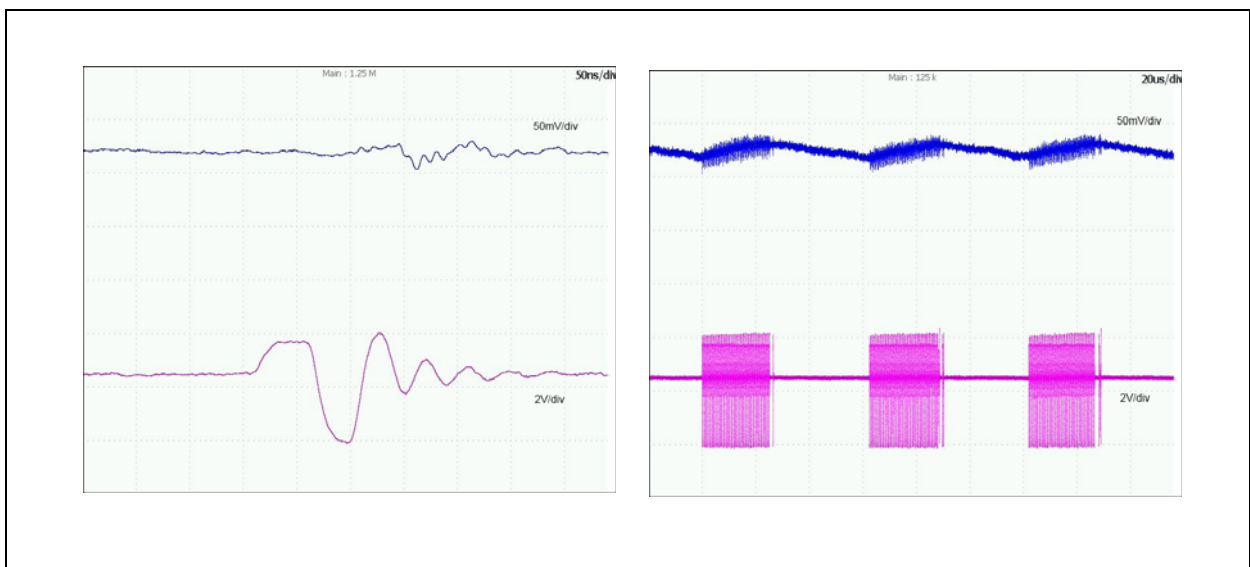

Operating Point 2: These graphs show the switching behavior referring to the operating point 2 from figure 10. Here the mode is set to low noise/low ripple operation and the DCDC has already started to skip pulses, as the minimum PMOS ON time of 40ns has been reached and the load current is further decreasing down to 2mA.

High-Efficiency Operation (Default Setting)

High-efficiency operation is enabled by setting the bit `sd_low_noise` [`SD_control1`] to 0.

In this mode there is a minimum coil current necessary before switching OFF the PMOS. Resultant there are less pulses necessary at low output loads, and therefore the efficiency increases. As drawback, this mode increases the ripple up to a higher output current.

Figure 13:
Switching Behavior at Operating Point 1

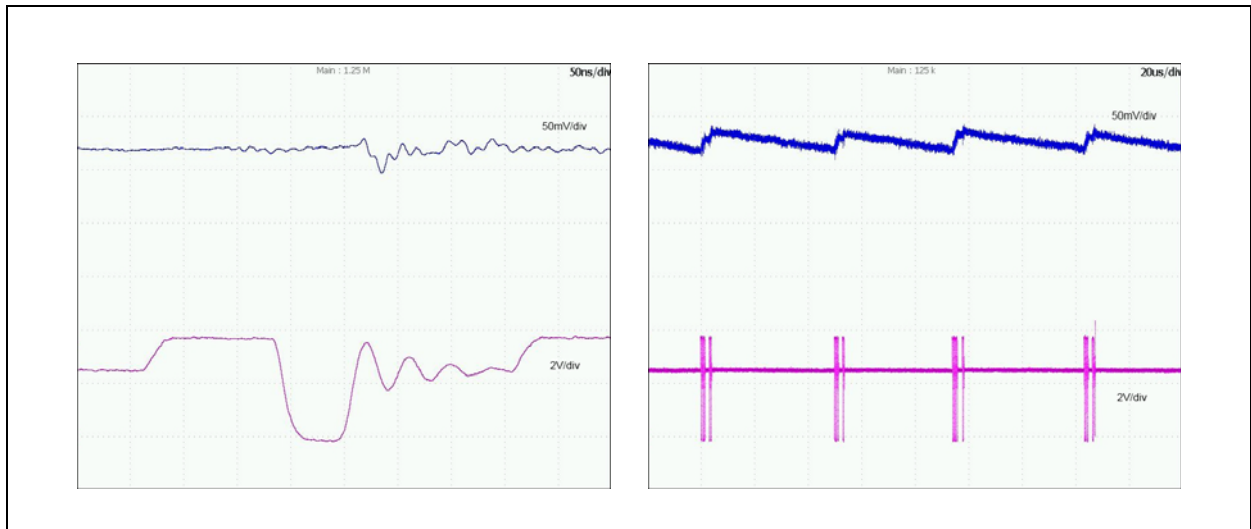

Operating Point 1: These graphs show the switching behavior referring to the operating point 1 from figure 10. Here the mode is set to high efficiency operation and the DCDC is in skipping mode at 2mA load current. Here a minimum coil current during the PMOS ON time is needed, hence more energy can be stored, the duration between the bursts is longer and the efficiency increases.

Figure 14:
Output Voltage Ripple Measurement at Operating Point 3

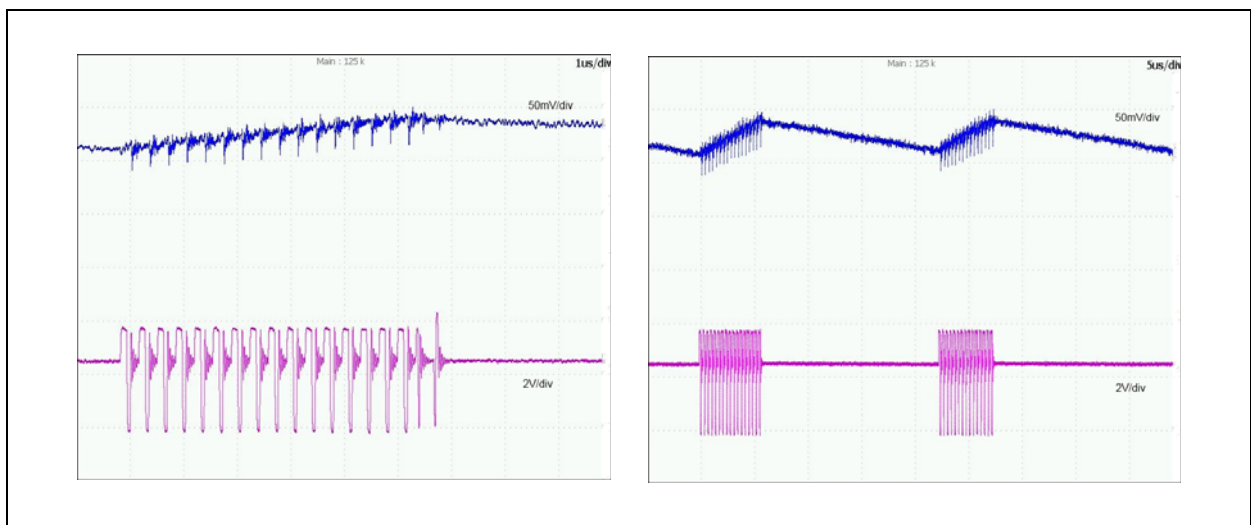

Operating Point 3: These graphs show the switching behavior referring to the operating point 3 from figure 10. Here the mode is set to high efficiency operation and comparing to operating point 4 the DCDC is still in skipping mode at 10mA load current and keeps the efficiency higher.

Figure 15:
Output Voltage Ripple Measurement at Operating Point 5

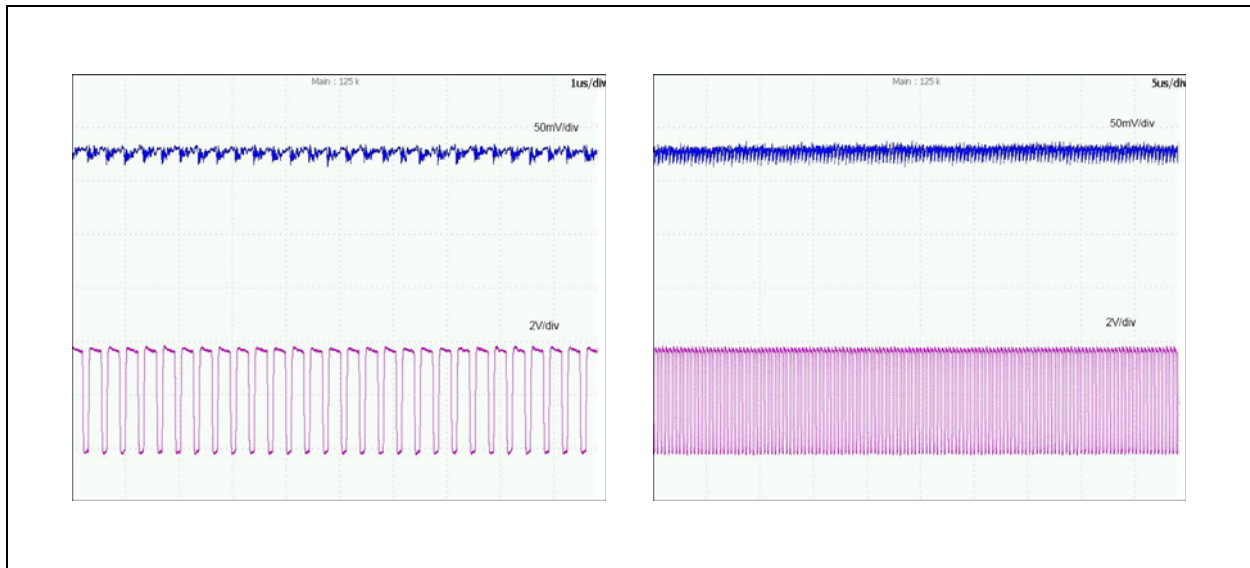

Operating Point 5: These graphs show the switching behavior referring to the operating point 5 from figure 10. Here the load current is 100mA and high enough to keep the DCDC always in a continuous switching operation regardless of the mode setting.

Low Power Mode Operation (Automatically Controlled)

As soon as the output voltage stays above the desired target value for a certain time, some internal blocks will be powered down leaving the output floating to lower the power consumption. Normal operation starts as soon as the output drops below the target value for a similar amount of time. To minimize the accuracy error some internal circuits are kept powered to assure a minimized output voltage ripple.

Two addition guard bands, based on comparators, are set at $\pm 5\%$ of the target value to react quickly on large over/undershoots by immediately turning ON the output drivers without the normal time delays. This ensures a minimized ripple also in very extreme load conditions.

Dynamic Voltage Management

To minimize the over-/undershoot during a change of the output voltage, the DVM can be enabled with `dvm_enable [SD_control2]`. With DVM the output voltage will ramp up/down with a selectable slope after the new value was written to the registers. The DVM time can be chosen between $8\mu\text{s}$ and $16\mu\text{s}$ by setting the bit `dvm_time [SD_control2]`. Without DVM the slew rate of the output voltage is only determined by external components like the coil and load capacitor as well as the load current.

Fast Regulation Mode

This mode can be used to react faster on sudden load changes and thus minimize the over-/undershoot of the output voltage. This mode needs a 22 μ F output capacitor instead the 10 μ F one to guarantee the stability of the regulator.

The mode is enabled by setting the bit *sd_fast* [*SD_control1*] to 1.

Selectable Frequency Operation

Especially for very low load conditions, e.g. during a sleep mode of a processor, the switching frequency can be reduced to achieve a higher efficiency. The frequency can be set to 1, 2, 3 or 4MHz and this mode is selected by setting *sd1_freq* [*SD1Voltage*] and *sd1_fsel* [*SD_control1*] to the appropriate values.

Parameters

Figure 16:
DCDC Step-Down Converter Electrical Characteristics

| Symbol | Parameter | Note | Min | Typ | Max | Unit |
|-----------------|--------------------------|--------------------------------|--------|------|------|----------|
| V_{IN} | Input Voltage | Pin VSUP | 2.7 | | 5.5 | V |
| V_{OUT} | Regulated Output Voltage | | 0.6125 | | 3.35 | V |
| V_{OUT_TOL} | Output Voltage Tolerance | min. 40mV | -3 | | +3 | % |
| I_{LIMIT} | Current Limit | | | 800 | | mA |
| R_{PMOS} | P-switch ON resistance | | | 0.36 | 1 | Ω |
| R_{NMOS} | N-switch ON resistance | | | 0.33 | 1 | Ω |
| f_{SW} | Switching Frequency | | 1 | 3 | 4 | MHz |
| I_{LOAD} | Load Current | | | 500 | | mA |
| I_{SUP_DCDC} | Current Consumption | Operating Current without Load | | 27 | | μ A |
| | | Shutdown Current | | 0.1 | | |
| t_{MIN_ON} | Minimum ON Time | | | 40 | | ns |

Figure 17:
DCDC Step-Down Converter External Components

| Symbol | Parameter | Note | Min | Typ | Max | Unit |
|-----------------|------------------|--------------------|-----|-----|-----|---------------|
| C_{FB_SD1} | Output Capacitor | Ceramic X5R or X7R | 8 | 10 | | μF |
| C_{VSUP_SD1} | Input Capacitor | Ceramic X5R or X7R | | 2.2 | | μF |
| L_{SD1} | Inductor | 4MHz operation | | 1 | | μH |
| | | 3MHz operation | | 1 | | |
| | | 2MHz operation | | 1 | | |
| | | 1MHz operation | | 2.2 | | |

Figure 18:
DCDC Step Down Converter Efficiency vs. Load Current at 1MHz

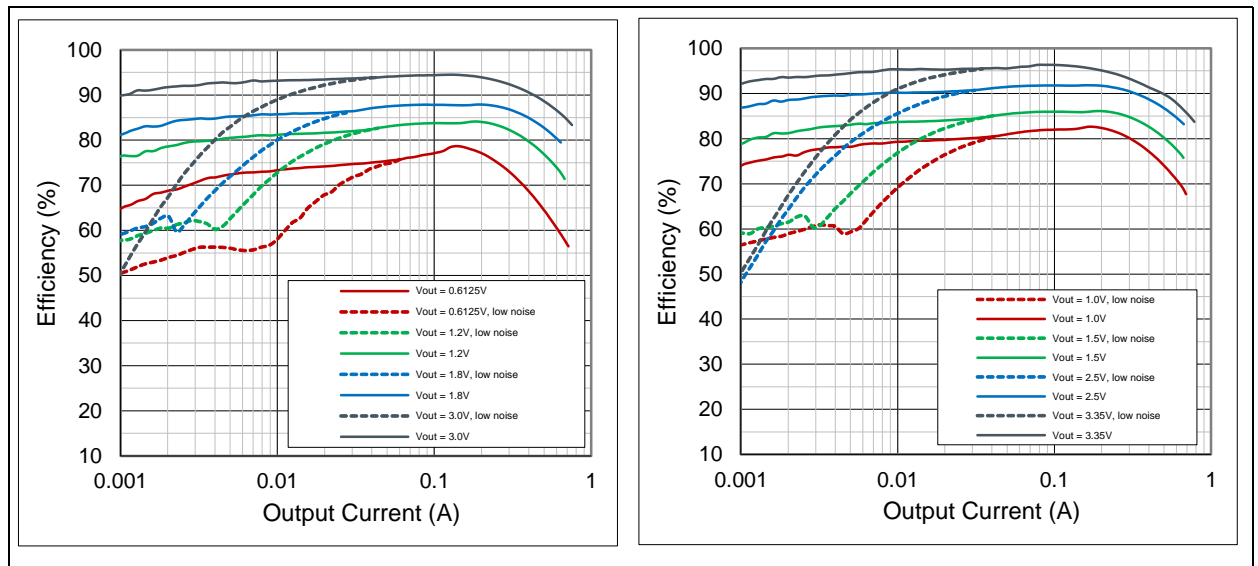

DCDC Efficiency vs. Output Current: $V_{SUP} = 3.7\text{V}$, $f_{SW} = 1\text{MHz}$, Murata LQM2HPN2R2MG0L 2.2 μH coil, $T_{AMB} = 25^\circ\text{C}$.

Figure 19:
DCDC Step Down Converter Efficiency vs. Load Current at 2MHz

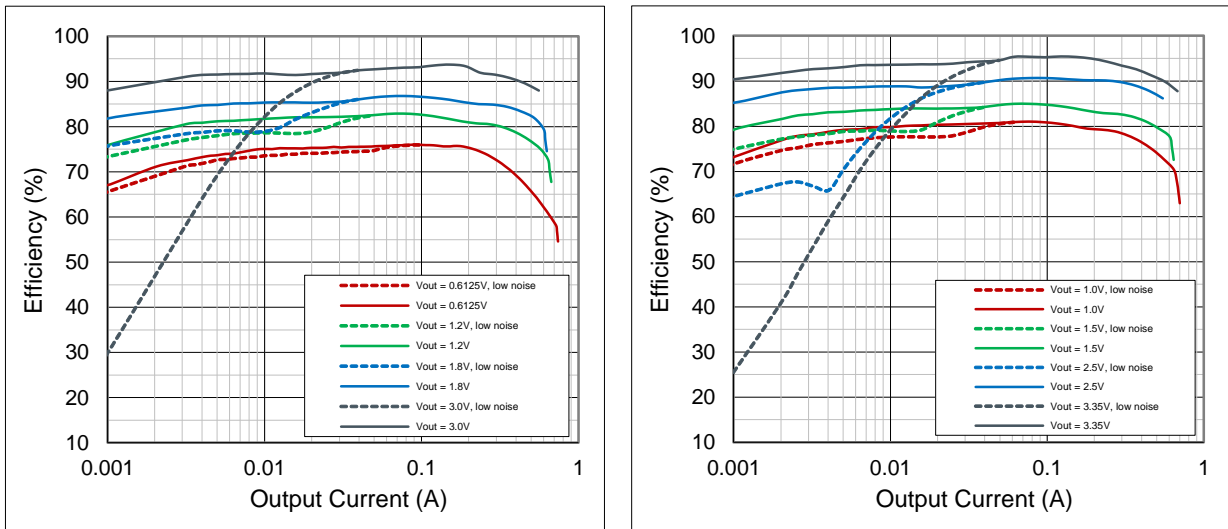

DCDC Efficiency vs. Output Current: $V_{SUP} = 3.7V$, $f_{SW} = 2MHz$, Murata LQM2HPN1R0MG0L 1 μ H coil, $T_{AMB} = 25^{\circ}C$.

Figure 20:
DCDC Step Down Converter Efficiency vs. Load Current at 3MHz

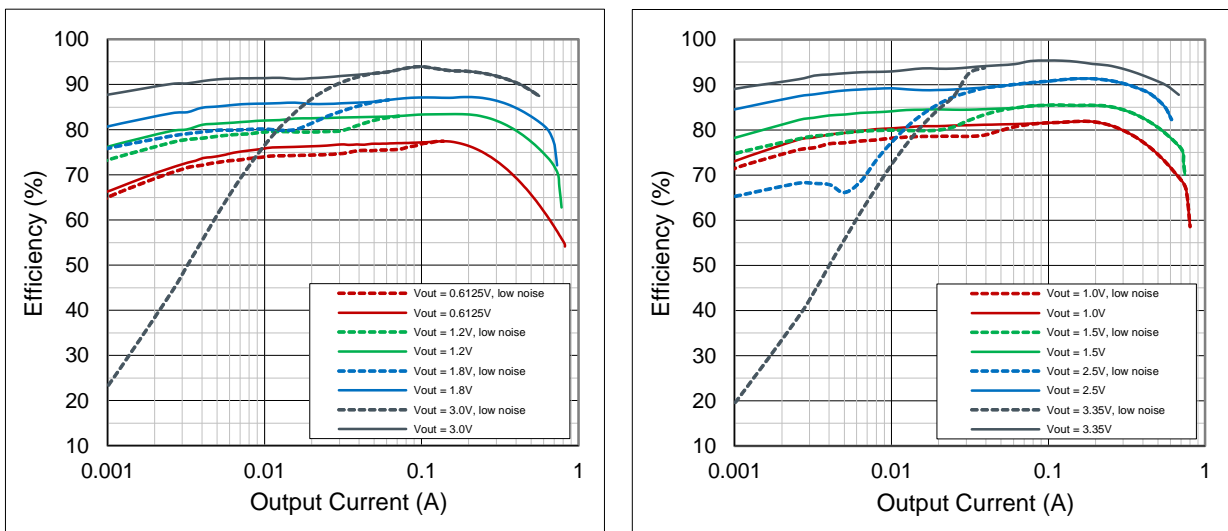

DCDC Efficiency vs. Output Current: $V_{SUP} = 3.7V$, $f_{SW} = 3MHz$, Murata LQM2HPN1R0MG0L 1 μ H coil, $T_{AMB} = 25^{\circ}C$.

Figure 21:
DCDC Step Down Converter Efficiency vs. Load Current at 4MHz

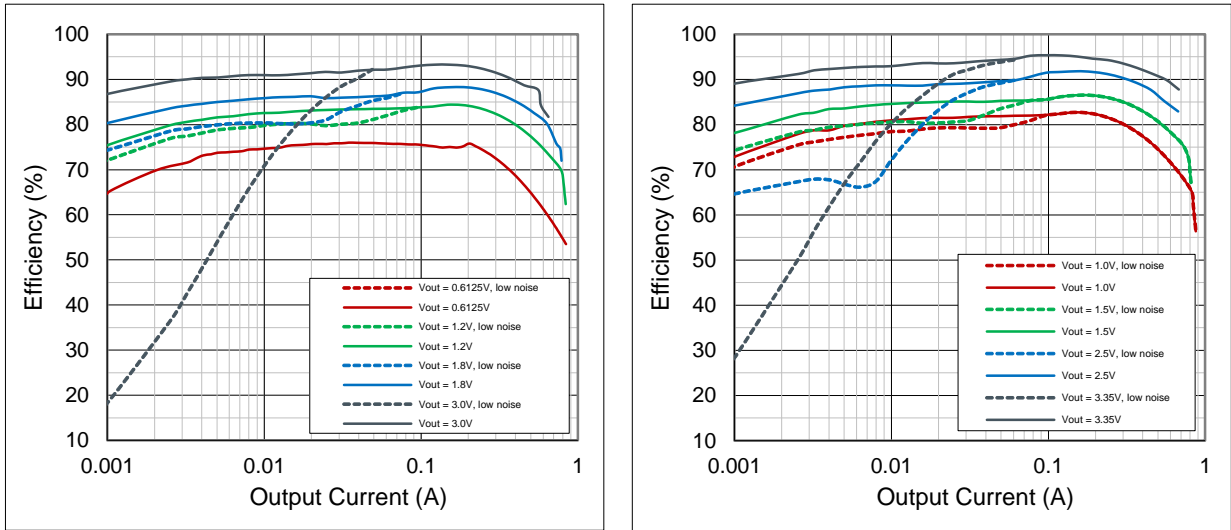

DCDC Efficiency vs. Output Current: $V_{SUP} = 3.7V$, $f_{SW} = 4MHz$, Murata LQM2HPN1R0MG0L $1\mu H$ coil, $T_{AMB} = 25^{\circ}C$.

Universal IO LDO Regulator

This LDO is a low-power and low-quiescent current linear-regulator specifically designed for space-limited applications. This device can supply loads up to 200mA and consist of an error amplifier, and a P-channel MOSFET pass transistor.

Figure 22:
Universal IO LDO Regulator Block Diagram

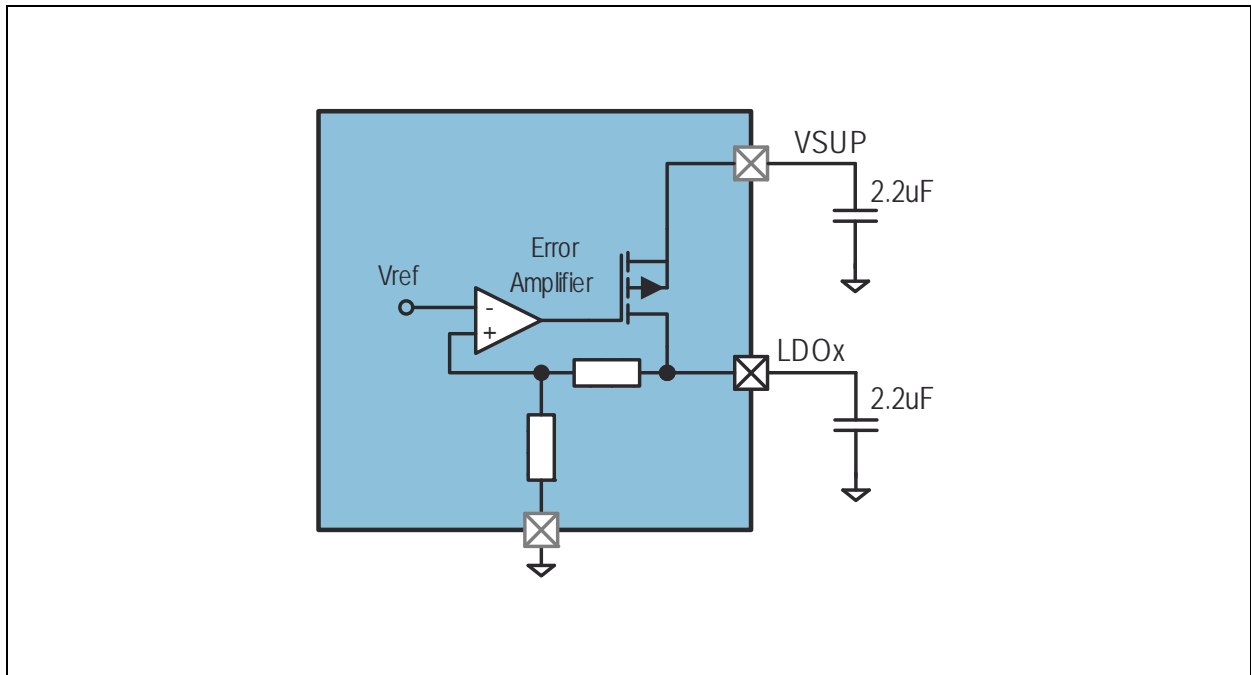

Parameters

Figure 23:
Universal IO LDO Regulator Electrical Characteristics

| Symbol | Parameter | Note | Min | Typ | Max | Unit |
|------------------|-------------------------|--|------|-----|------|------|
| V_{IN} | Input voltage | Pin VSUP | 2.7 | | 5.5 | V |
| ΔV_{OUT} | Output voltage accuracy | $I_{OUT} = 1\text{mA}, V_{OUT} > 2\text{V}$ $T_{AMB} = 25^\circ\text{C}$ Guaranteed by design | -2.5 | | +2.5 | % |
| | | $I_{OUT} = 100\mu\text{A to } 200\text{mA}$ $V_{OUT} > 2\text{V}$ | -3 | | +3 | |
| | | $I_{OUT} = 1\text{mA}, V_{OUT} \leq 2\text{V}$ $T_{AMB} = 25^\circ\text{C}$ Guaranteed by design | -20 | | +20 | mV |
| | | $I_{OUT} = 100\mu\text{A to } 200\text{mA}$ $V_{OUT} \leq 2\text{V}$ | -50 | | +50 | |

| Symbol | Parameter | Note | Min | Typ | Max | Unit |
|----------------|-------------------------|---|-----|-------|-----|---------------|
| V_{OUT} | Output voltage range | | 1.2 | | 3.3 | V |
| V_{LNR} | Line regulation static | $V_{IN} = 2.7V$ to $5.5V$ $I_{OUT} = 1mA$ | | 0.07 | | %/V |
| | Line regulation dynamic | $V_{IN} = 2.7V$ to $5.5V$ within $15\mu s$ $I_{OUT} = 1mA$ | | 20 | | mV |
| V_{LDR} | Load regulation static | $I_{OUT} = 100\mu A$ to $200mA$ | | 0.014 | | %/mA |
| | Load regulation dynamic | $I_{OUT} = 100\mu A$ to $200mA$ within $15\mu s$ | | 30 | | mV |
| R_{ON} | ON resistance | | | 0.5 | 1 | Ω |
| I_{OUT} | Guaranteed load current | RMS | 200 | | | mA |
| I_{LIMIT} | Short-circuit | $V_{OUT} = 0V$ | | 230 | | mA |
| I_Q | Quiescent current | No Load | | 5 | | μA |
| | | $I_{OUT} = 100\mu A$ | | 5 | | |
| | | $I_{OUT} = 200mA$ | | 15 | | |
| I_{OFF} | Shutdown supply current | LDO disabled | | 0.1 | 1 | μA |
| eN | Output noise | BW = 10Hz to 100Hz; $V_{OUT} = 1.2V$; $I_{OUT} = 1mA$; $C_{OUT} = 2.2\mu F$ | | 112 | | μV_{rms} |
| | | BW = 10Hz to 100Hz; $V_{OUT} = 3.3V$; $I_{OUT} = 1mA$; $C_{OUT} = 2.2\mu F$ | | 205 | | |
| t_{START} | Startup time | | | 750 | | μs |
| $t_{SHUTDOWN}$ | Shutdown time | | | 500 | | μs |

Figure 24:
Universal IO LDO Regulator External Components

| Symbol | Parameter | Note | Min | Typ | Max | Unit |
|------------|------------------|--------------------|-----|-----|-----|---------|
| C_{LDOx} | Output capacitor | Ceramic X5R or X7R | 2.2 | 4.7 | | μF |

Figure 25:
LDO Output Voltage vs. Output Current 1/2

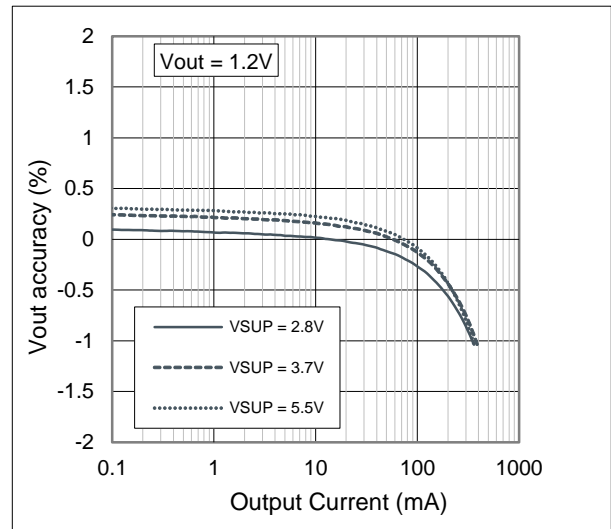
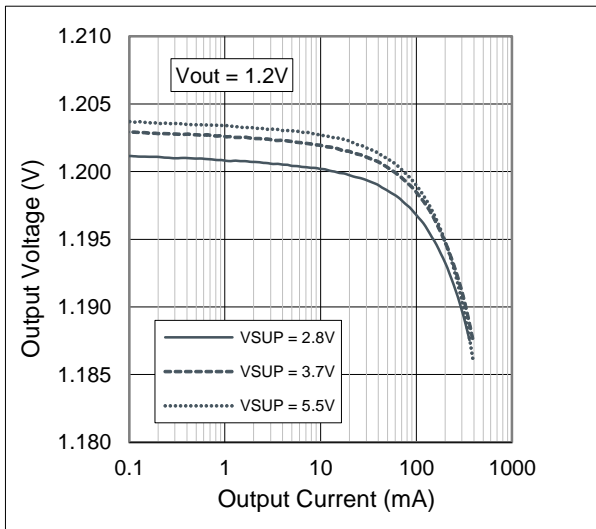

LDO Output Voltage vs. Output Current: $V_{OUT} = 1.2V$, $T_{AMB} = 25^{\circ}C$.

Figure 26:
LDO Output Voltage vs. Output Current 2/2

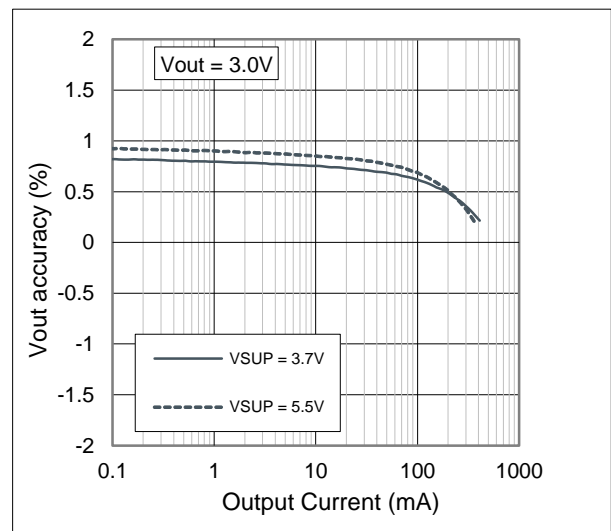
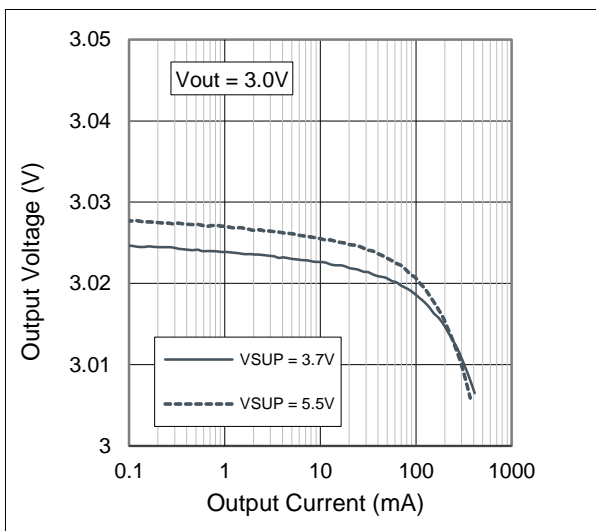

LDO Output Voltage vs. Output Current: $V_{OUT} = 3.0V$, $T_{AMB} = 25^{\circ}C$.

Figure 27:
LDO Load Transient Response 1/2

LDO Load Transient Response:

$V_{SUP} = 3.7V$, $V_{OUT} = 1.2V$, $t_{RISE} = 15\mu s$,
 $I_{OUT} = 100\mu A$ to $200mA$, $T_{AMB} = 25^{\circ}C$.
 (Blue channel: V_{OUT} ; Red channel: I_{OUT})

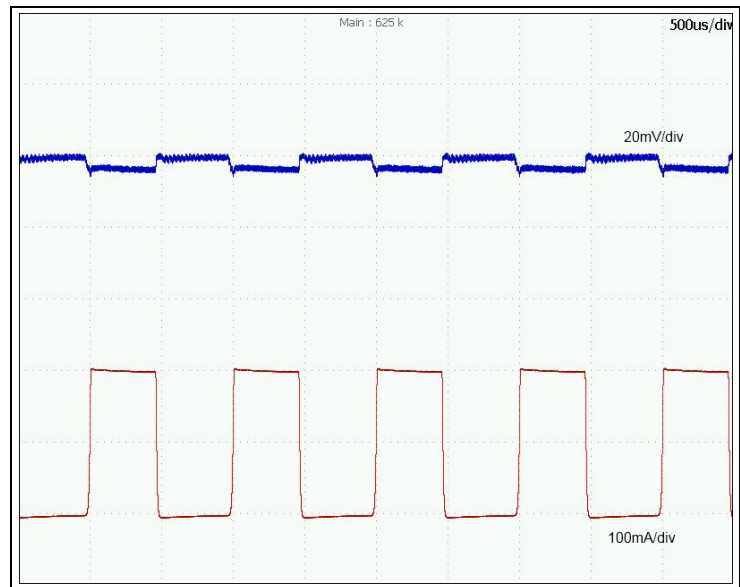
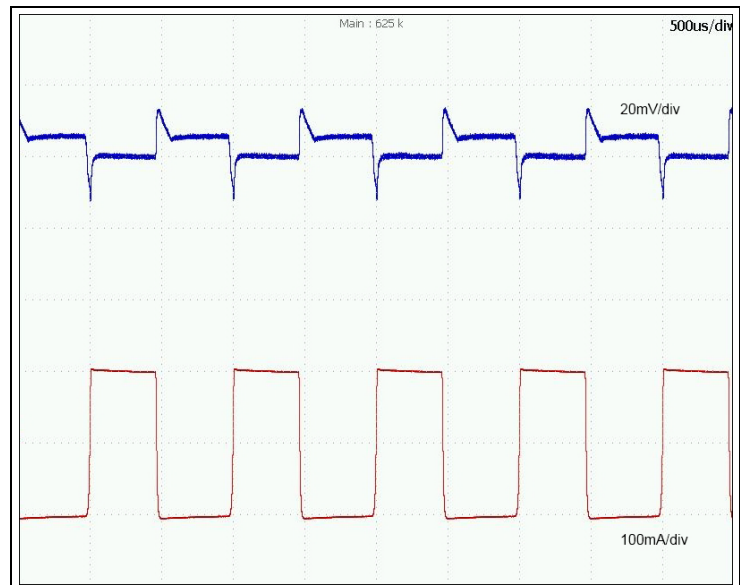

Figure 28:
LDO Load Transient Response 2/2

LDO Load Transient Response:

$V_{SUP} = 3.7V$, $V_{OUT} = 3.0V$, $t_{RISE} = 15\mu s$,
 $I_{OUT} = 100\mu A$ to $200mA$, $T_{AMB} = 25^{\circ}C$.
 (Blue channel: V_{OUT} ; Red channel: I_{OUT})



Linear Charger

This block can be used to charge Li-Ion batteries. Requiring less external components, a full-featured battery charger with a high degree of flexibility can easily be realized. The main features of the controller are:

- Charge adapter detection
- Power Path management for dead battery startup
- Low current Trickle charging
- Constant current charging
- Constant voltage charging
- Operation without battery
- Battery presence indication
- NTC temperature supervision
- Input current limitation

Figure 29:
Linear Charger Block Diagram

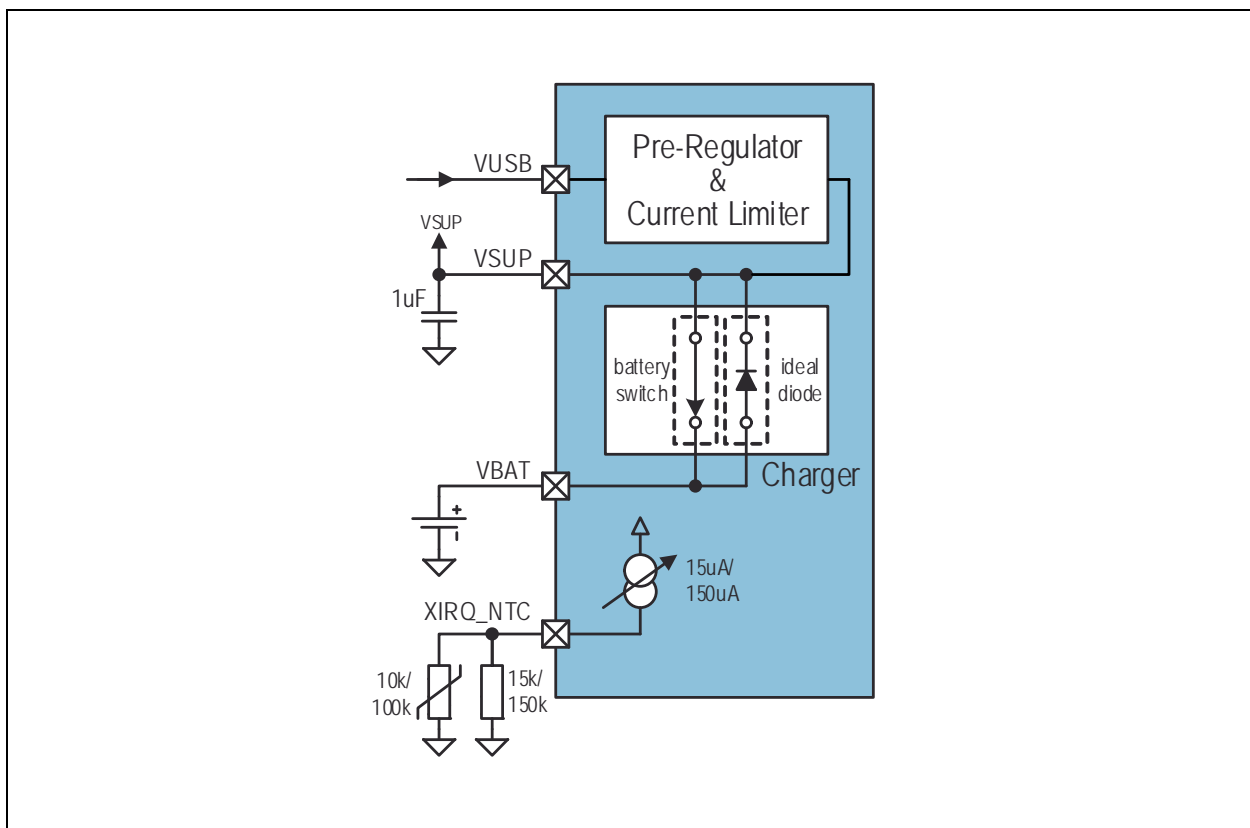
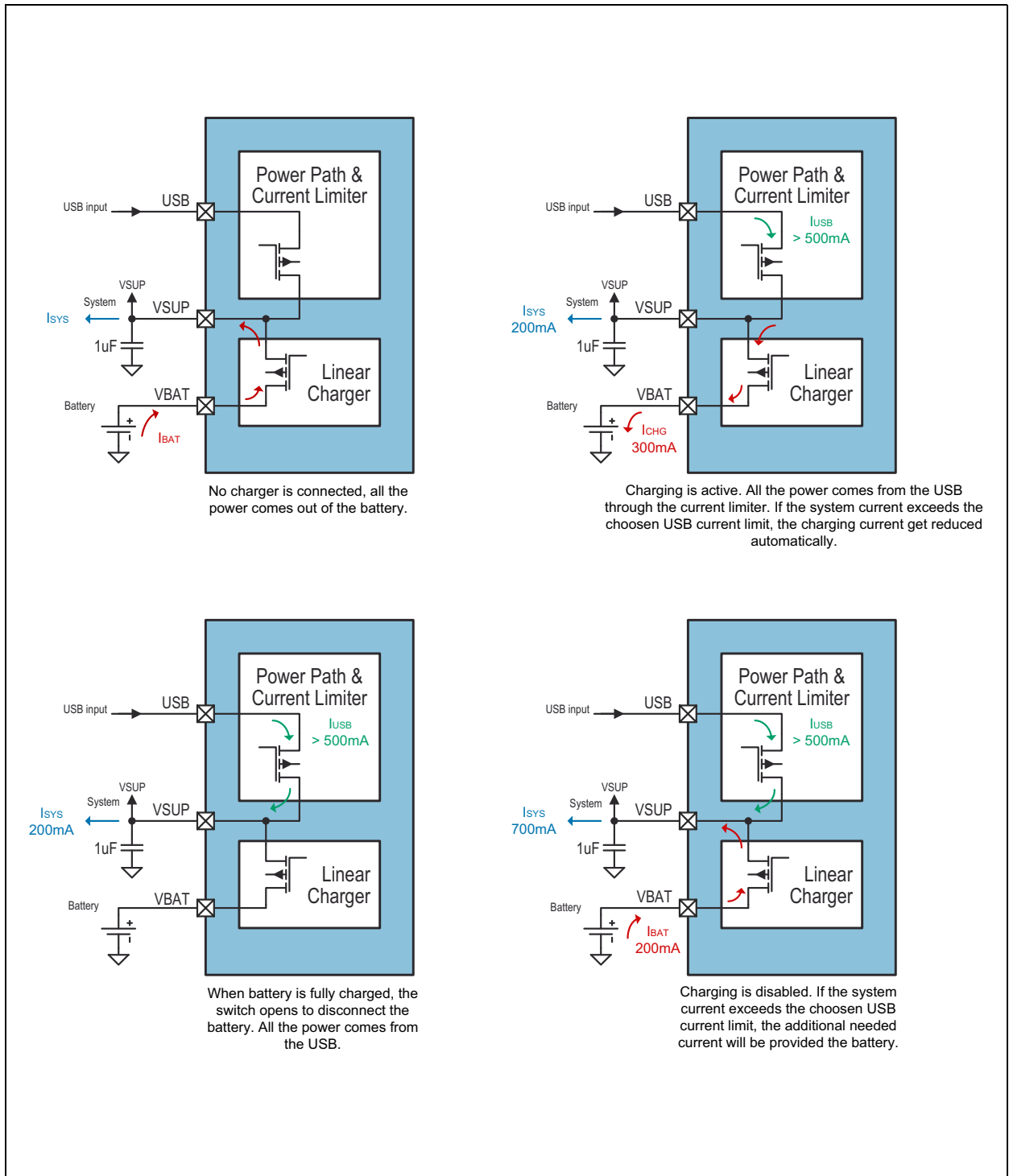

Figure 30:
Linear Charger Modes



Charging Modes: This figure describes the 4 different charger modes.

Charging Cycle Description

Charge Adapter Detection

The charge controller uses an integrated detection circuit to determine if an external charge adapter has been applied to the VUSB pin. If the adapter voltage exceeds the battery voltage at pin VBAT by V_{CHDET} the *ChDet* [*ChargerStatus2*] will be set. The detection circuit will reset the charge controller (bit *ChDet* is cleared) as soon as the voltage at the VUSB pin drops to only V_{CHMIN} above the battery voltage. In case the AS3701 device is reset the charge controller will also be reset, even if a charge adapter is applied to the VUSB pin. The Charger detection can be disabled by setting the bit *chdet_off* [*ChargerStatus2*] to “1”, which results in a further decrease of internal power consumption.

Low Current (Trickle) Charging

Trickle charge mode is started when an external charge adapter has been detected, the bit *bat_charging_enable* [*ChargerControl*] is set and the battery voltage at pin VBAT is below the $V_{TRICKLE}$ threshold; bits *ChDet* and *Trickle* [*ChargerStatus1*] will be set. In this mode the charge current will be limited to *TrickleCurrent* [*ChargerCurrentControl*] to prevent undue stress in case of deeply discharged batteries. Once $V_{TRICKLE}$ has been exceeded, the charger will change over to constant current charging (*Trickle* is cleared).

Constant Current Charging

Constant current charging is initiated when *bat_charging_enable* [*ChargerControl*] and the battery voltage at pin VBAT is above the $V_{TRICKLE}$ and below V_{CHOFF} . The bit *CCM* [*ChargerStatus1*] is set when the charger has started, and the charge current will be limited by the battery charge controller. The current for the Constant Current Charging can be selected out of the range defined in *ConstantCurrent* [*ChargerCurrentControl*] if the bit *cc_range_select* [*ChargerControl*] is set to “0” or out of the range defined in *TrickleCurrent* [*ChargerCurrentControl*] if the bit *cc_range_select* [*ChargerControl*] is set to “1”. When the battery approaches full charge, its voltage will reach the charge termination threshold V_{CHOFF} . V_{CHOFF} depends on the *ChVoltEOC* [*ChargerVoltageControl*] bits settings. Top-OFF charge will be started and the bit *CVM* [*ChargerStatus1*] will be set.

Constant Voltage Charging

Constant voltage charge mode is initiated and the bit *CVM* [*ChargerStatus1*] will be set when the V_{CHOFF} threshold has been reached. The charge current is monitored during constant voltage charging. It will be decreasing from its initial value during constant current charging and eventually drops below 5% or 50% of the Constant Current value (depends on the

setting of the bit *eoc_current* [*ChargerCurrentControl*]). If the measured charge current is less than or equal to *eoc_current*, the charging cycle is terminated and *EOC* [*ChargerStatus1*] is set.

Resume

If EOC is reached and the bit *AutoResume* [*ChargerControl*] is set, the charging will immediately start again, if the battery voltage falls below the specified resume voltage *ChVoltResume* [*ChargerConfig1*]. This voltage can be set either to 3.33% or 5.56% of *ChVoltEOC* [*ChargerVoltageControl*].

Figure 31:
Resume Voltage Levels

| ChVoltResume | ChVoltEOC | | | | | | |
|--------------|-----------|-------|-----|-------|-----|-------|-------|
| | 3.82V | 3.84V | ... | 4.20V | ... | 4.42V | 4.44V |
| 3.33% | 127mV | 128mV | ... | 140mV | ... | 147mV | 148mV |
| 5.56% | 212mV | 213mV | ... | 233mV | ... | 246mV | 247mV |

Figure 32:
Linear Charger States

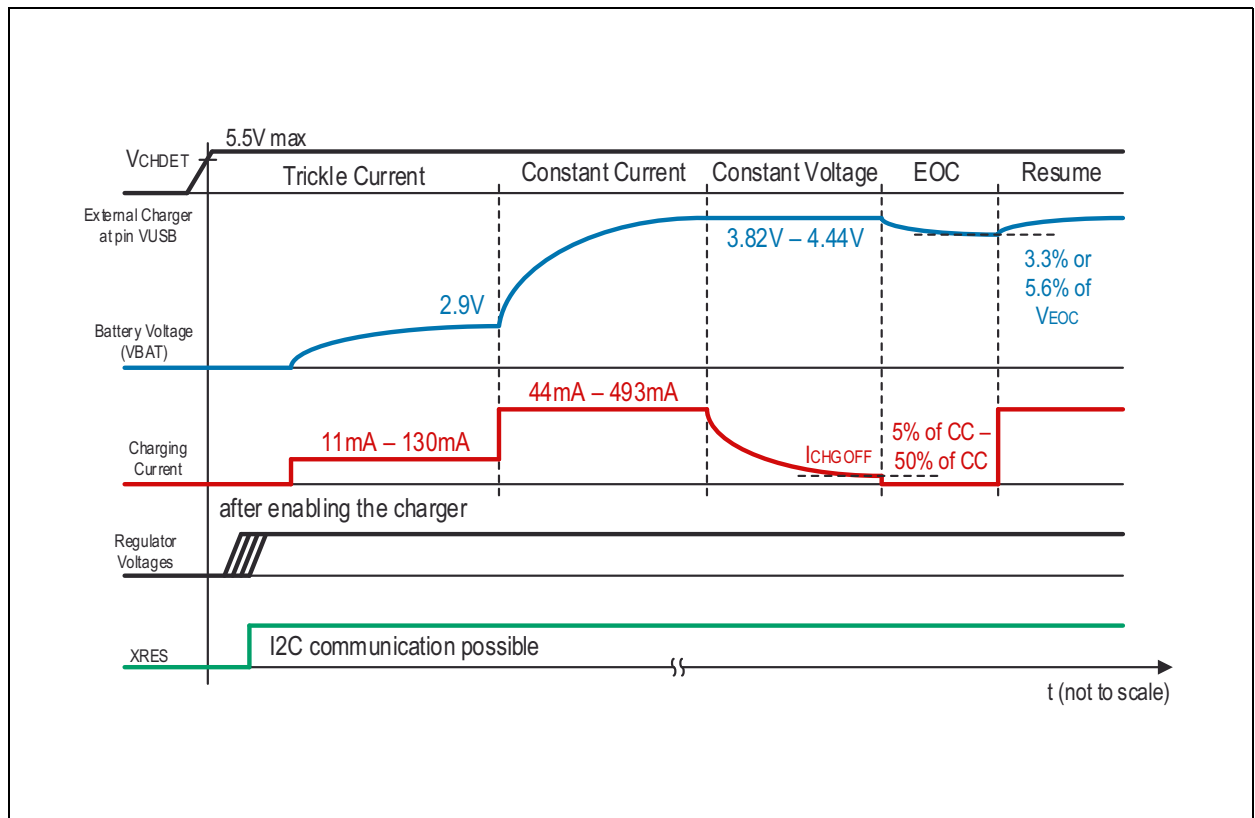

Charging States: This figure describes the characteristics of the charging current and the battery voltage for each different charging state.

Stop Charging Conditions

There are multiple safety features implemented triggering a stop_charging condition.

These are the following:

- Battery temperature is too high: If *ntc_high_on* [*ChargerSupervision*] = 1 and the voltage at pin NTC (GPIO3, GPIO4 or XIRQ_NTC) is below $V_{BATTEMP}$.
- Battery temperature is too low: If *ntc_low_on* [*ChargerSupervision*] = 1 and the voltage at pin NTC (GPIO3, GPIO4 or XIRQ_NTC) is above $V_{BATTEMP}$.
- Charging timeout timer expired: If *ch_timeout* [*ChargerConfig2*] > 0 and charging time has been exceeded. (Can be reset by unplugging the charger, setting *bat_charging_enable* [*ChargerControl*] = 0 or writing *charging_tmax* [*ChargerConfig2*] = 0)
- Die temperature > 140°C (*ov_temp_140* [*OvertemperatureControl*] is set)
- Reset is initiated (each Reset reason forces a stopping of the charging)

Battery Presence Indication

After EOC state is reached, a timer for NOBAT detection is started. If there is no battery present, the VBAT voltage will drop to VRESUME. Depending on the load on VBAT and the capacitor on VBAT this might take some milliseconds to 1 second. If *AutoResume* [*ChargerControl*] is enabled, the charger will restart charging (Constant Current Charging) after 100ms delay.

The 100ms dead time is necessary to get a battery oscillation frequency below 10Hz, if there is no battery present.

If the NOBAT detection timer is below 2 seconds after reaching the EOC state, and this happens 2 times in serial, the bit *NoBat* [*ChargerStatus1*] is set. If a battery is inserted, the bit will be reset after the timer exceeds the 2 seconds.

NTC Supervision

Configuration

The AS3701 also features a supply for an external NTC resistor to measure the battery temperature while charging. For AS3701A, the pin XIRQ_NTC can be used as the NTC input pin, whilst AS3701B additionally offers the GPIO3 and GPIO4. With the bit *NTC_input* [*ChargerSupervision*] the NTC Supervision can be configured.

Figure 33:
NTC Supervision Configuration

| NTC_input | | NTC Supervision Configuration |
|-----------|---|-----------------------------------|
| 0 | 0 | No NTC supervision ⁽¹⁾ |
| 0 | 1 | XIRQ_NTC pin |
| 1 | 0 | GPIO3 pin ⁽²⁾ |
| 1 | 1 | GPIO4 pin ⁽²⁾ |

Note(s):

1. If no NTC supervision is selected, all NTC relevant bits are ineffective
2. AS3701B only

NTC Resistor

Depending on the used resistor value of the NTC (10k or 100k) the internal NTC current (150µA for 10k or 15µA for 100k) can be selected via *ntc_10k* [*ChargerSupervision*].

High/Low Temperature

The battery high temperature supervision is controlled with the bit *ntc_high_on* [*ChargerSupervision*] and this feature is enabled per default. If the temperature is higher than 45°C or 60°C (depending on *ntc_mode* [*ChargerSupervision*]) the flag *temp_cond* [*ChargerStatus1*] will be set and the charger will stop operation. When the battery temperature drops and the voltage on NTC pin rises above $V_{BATTEMP_HIGH_OFF}$, the flag *temp_cond* will be reset and the charger will continue with the charging again.

The battery low temperature supervision is controlled with the bit *ntc_low_on* [*ChargerSupervision*] and this feature is disabled per default. If the temperature is lower than 0°C the flag *temp_cond* [*ChargerStatus1*] will be set and the charger will stop operation. When the battery temperature rises and the voltage on NTC pin falls below $V_{BATTEMP_LOW_OFF}$, the flag *temp_cond* will be reset and the charger will continue with the charging again.

The detection of a high or low battery temperature can also be indicated with a dedicated interrupt mask bit *bat_temp_m* [*InterruptMask2*].

For the high and low temperature supervision, a temperature hysteresis is included to avoid an oscillation of the charger.

The supply for the NTC will be on when either the *ntc_high_on* or the *ntc_low_on* bit is set, no matter if a charger is detected or not. Therefore the battery temperature supervision can be used for charging mode and also for discharging mode.

NTC β -Correction

To keep the voltage drop over the whole temperature range inside of the comparator threshold voltage range, a 15k (150k) parallel resistor to the 10k (100k) NTC is needed. With the bit *ntc_beta* [ChargerSupervision] 4 different β -values depending on the used NTC resistor can be selected.

Figure 34:
NTC β Influence Over Temperature

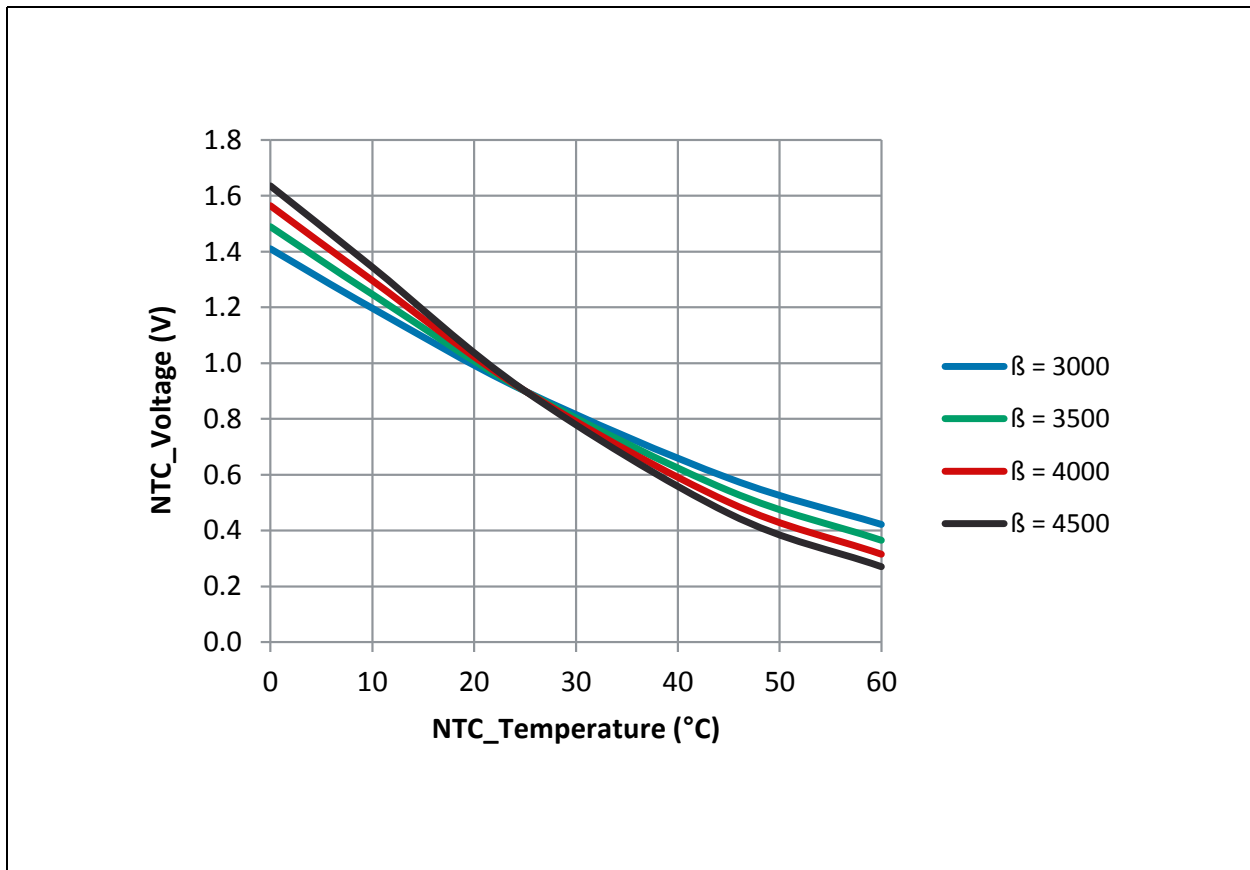

NTC β Influence Diagram: Shows the voltage drop over the NTC resistor depending on the temperature for 4 different β values using $R_{NTC}=10k\Omega$, $R_p=15k\Omega$ and $I_{NTC}=150\mu A$.

Figure 35:
NTC Threshold Voltages

| Temperature | | β | | | | Unit |
|------------------|------|---------|------|------|------|------|
| | | 3000 | 3500 | 4000 | 4500 | |
| Low temperature | 0°C | 1.41 | 1.49 | 1.56 | 1.63 | V |
| High temperature | 45°C | 0.59 | 0.54 | 0.50 | 0.46 | V |
| | 60°C | 0.42 | 0.37 | 0.31 | 0.27 | V |

NTC Supervision: Comparator threshold voltages for different temperatures and β using $R_{NTC}=10k\Omega$, $R_p=15k\Omega$ and $I_{NTC}=150\mu A$.

Charger High/Low Temperature Supervision

Figure 36:
High/Low Temperature Supervision

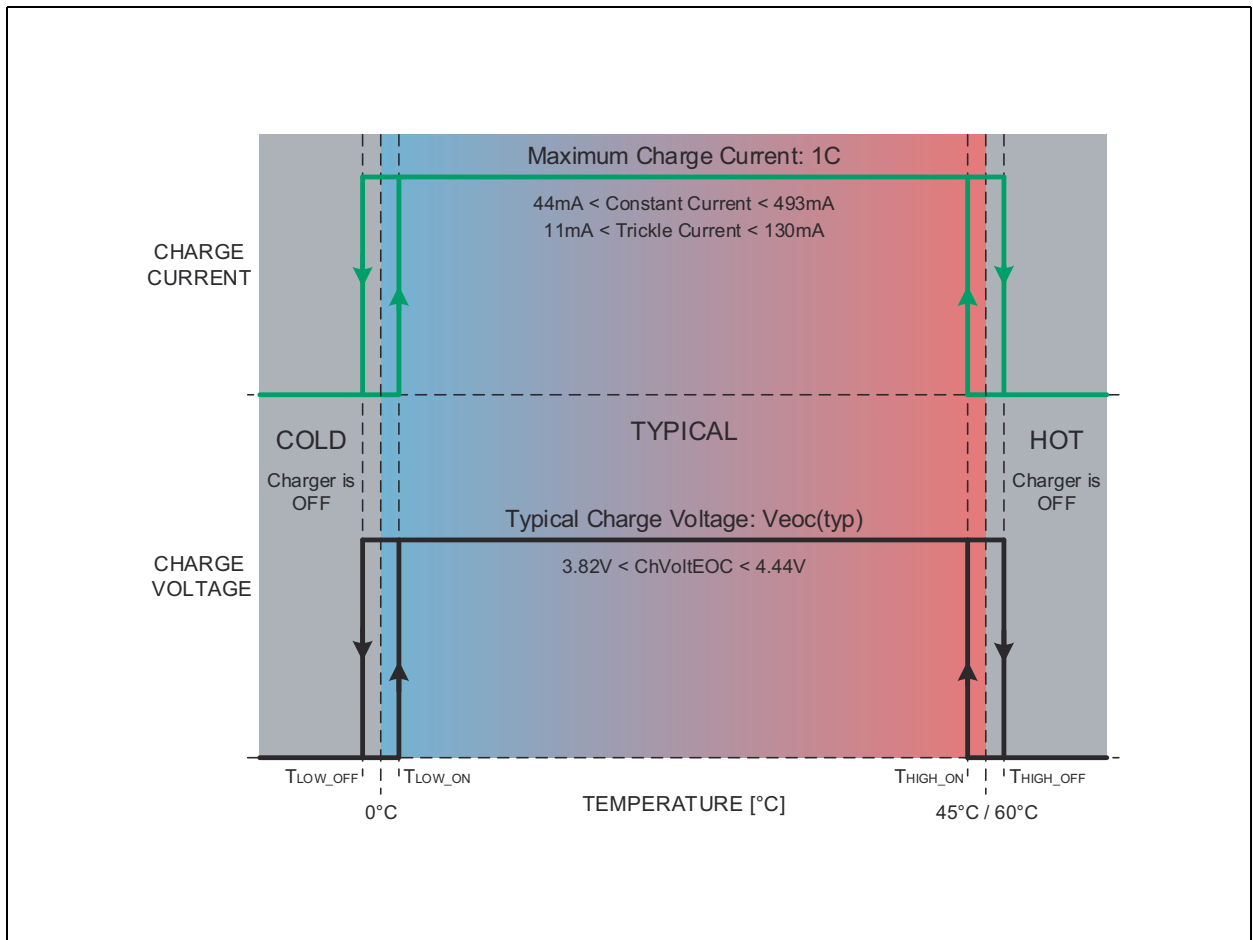

Temperature Supervision Diagram: Shows the voltage and current settings for the high and low temperature supervision.

Parameters

Figure 37:
Linear Charger Electrical Characteristics

| Symbol | Parameter | Note | Min | Typ | Max | Unit |
|-------------------|--|--|------|----------------|------|----------|
| $I_{TRICKLE}$ | Trickle current | 11 steps programmable | | 11.. 130 | | mA |
| $V_{TRICKLE}$ | Trickle to constant current threshold | V_{BAT} rising | | 2.9 | | V |
| I_{CHG} | Constant current | $cc_range_select = 0$ | | 44.. 493 | | mA |
| | | $cc_range_select = 1$ | | 11.. 130 | | mA |
| | | @ 70mA | -8% | 70 | +8% | mA |
| V_{EOC} | Charge termination threshold | Programmable in 20mV steps | | 3.82.. 4.44 | | V |
| | | end of charge is true | 4.15 | 4.2 | 4.25 | V |
| I_{EOC} | EOC current level | referring to I_{CHG} ($V_{SUP} > 3V$) | | 5.. 50 | | % |
| I_{USB_limit} | VUSB input current limit | @470mA | 420 | 470 | 500 | mA |
| V_{SUP_prereg} | Voltage supplied from Preregulator | Depending on the bit $vsup_voltage$ | | 4.4.. 5.5 | | V |
| V_{RESUME} | Resume Voltage limit to start charger | V_{BAT} falling threshold referring to V_{EOC} (depending on bit $ChVoltResume$) | | 3.3 5.6 | | % |
| V_{SUP_MIN} | VSUP level for charging current reduction, to avoid voltage drop on VSUP | Trickle or constant current will be regulated down, if VSUP drops below this threshold | -6% | 3.9 | +3% | V |
| | | | | 4.2 | | |
| | | | | 4.5 | | |
| | | | | 4.7 | | |
| V_{CHDET} | Charger detection hysteresis | $V_{USB} - V_{BAT}$ Hysteresis is > 40mV | 50 | 75 | 105 | mV |
| V_{CHMIN} | | | 0 | 20 | 35 | mV |
| I_{REV_OFF} | Reverse current shut down | $V_{SUP} = 5V$, V_{USB} open | | <1 | | uA |
| R_{ON_BATSW} | Battery switch ON-resistance | | | 0.4 | | Ω |

Figure 38:
Capacitor Selection for VUSB, VSUP_CHG and VBAT

| Symbol | Parameter | Note | Min | Typ | Max | Unit |
|-----------------|------------------|--------------------|-----|-----|-----|---------------|
| C_{VUSB} | Input capacitor | Ceramic X5R or X7R | | 10 | | μF |
| C_{VSUP_CHG} | Output capacitor | Ceramic X5R or X7R | | 10 | | μF |
| C_{VBAT} | Output capacitor | Ceramic X5R or X7R | | 10 | | μF |

Selection of Bypass Capacitors for the Pins VUSB, VSUP_CHG and VBAT

In most applications using the ideal capacitance values shown in the table and the application schematic are recommended. After evaluation of the voltage signals on these pins with real system operational conditions at the user's application circuit, the user can determine if this ideal capacitance values needs to be adjusted.

It must be kept in mind that the capacitance value depends strongly on the rated voltage, therefore a selection of the appropriate nominal capacitor value related to the capacitor size is mandatory to achieve best performance under the specific operational voltage and load current condition of the application system.

Current Sinks

The following description of the Current Sinks refers only to the pins GPIO1_CURR1 and GPIO2_CURR2. Hence the suffix "X" stands either for 1 or for 2.

The AS3701 contains 2 GPIO pins (GPIO1_CURR1 and GPIO2_CURR2), providing general purpose current sinks when the register *gpioX_mode* [GPIOXcontrol] is set to CURRx input. Next to this setting, the register *gpioX_iosf* [GPIOXcontrol] must be set to one of the GPIO output functions (please see the GPIO section in the following chapter "Detailed Description – System Functions").

Parameters**Figure 39:**
Current Sinks Electrical Characteristics

| Symbol | Parameter | Note | Min | Typ | Max | Unit |
|------------------|---|--|------|-----|-----------------------|------|
| I_{CURRx} | CURR1_current = 01h – FFh CURR2_current = 01h – FFh | Resolution = 156.86 μ A | 0.16 | | 40 | mA |
| I_{CURRx_TOL} | CURR current accuracy | CURRx_current = 40h | 9.3 | 10 | 10.7 | mA |
| V_{CURRx} | Voltage compliance | During normal operation | 0.5 | | 5.5 | V |
| $V_{PROTECT}$ | Maximum voltage at pin CURRx to protect driver transistor | $I_{SINK} > 20\text{mA}$ guaranteed by design | | | $V_{BAT} + 2\text{V}$ | V |

Detailed Description – System Functions

Start-Up

Normal Start-Up

The following gives a brief description on a start-up from scratch (battery or charger insertion). More details can be found in the start-up flow chart.

A start-up can be activated from 5 different sources:

- Battery insertion from scratch
- Charger insertion from scratch ($V_{BAT} < ResVoltFall$)
- ON-key has been pulled high in power_off mode
- Reset cycle
- $ResVoltRise$ level was reached

During a normal reset cycle a normal startup happens:

- Setting USB current limit and $ResVoltRise$
- Startup State machine reads out the internal Boot-OTP. The start-up sequence of SD Converter, LDOs and GPIOs are controlled by the Boot-OTP
- Reset-Timer is set by the Boot-OTP
- The reset is released when the Reset Timer expires (external pin XRES)

Parameter

Figure 40:
Start-Up Condition

| Symbol | Parameter | Note | Min | Typ | Max | Unit |
|--------------------|--------------------|------------------------------------|-------------|-----|-------------|---------|
| V_{ON_IL} | Low level voltage | ON pin | | | 20% of VSUP | V |
| V_{ON_IH} | High level voltage | ON pin | 60% of VSUP | | | V |
| $I_{ON_PD}^{(1)}$ | Pull down current | Bit $on_invert = 0$ (active high) | 4 | 12 | | μA |

Note(s):

1. The internal pull-down resistor is just active if the bit on_invert is set to "0" (active high configuration). If the ON-key works active low ($on_invert = 1$) the internal pull-down resistor is deactivated and an external pull-up resistor is needed in push-button configuration!

Figure 41:
Start-Up Flowchart

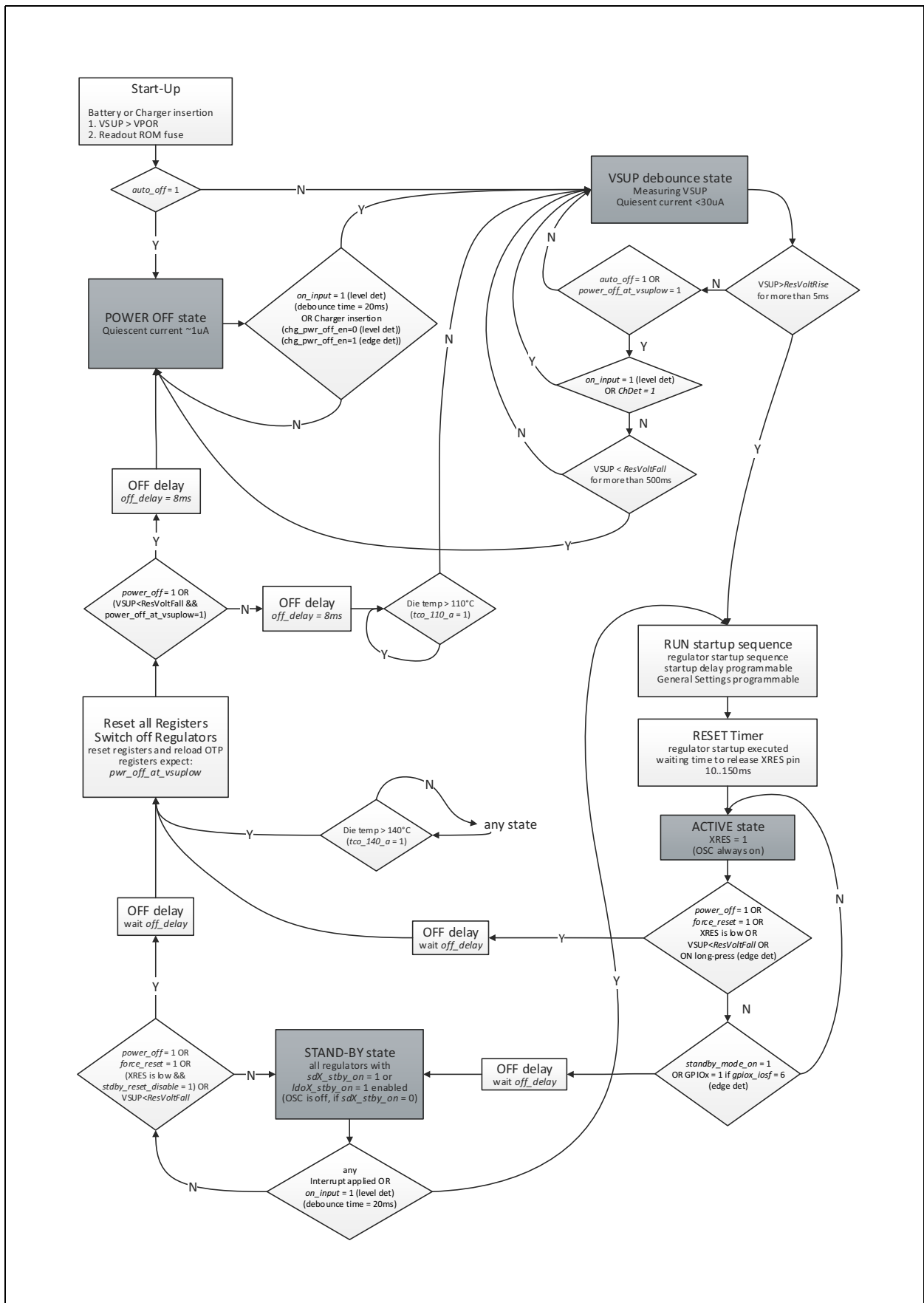
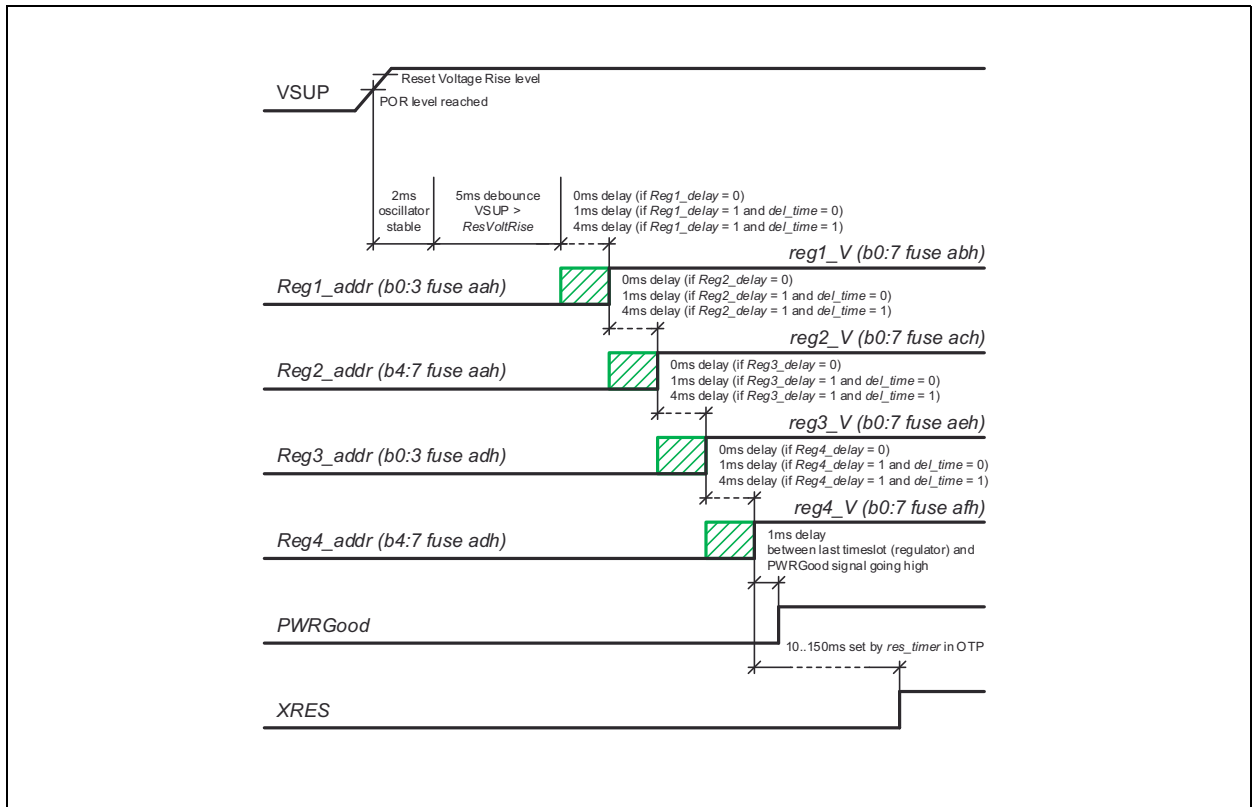
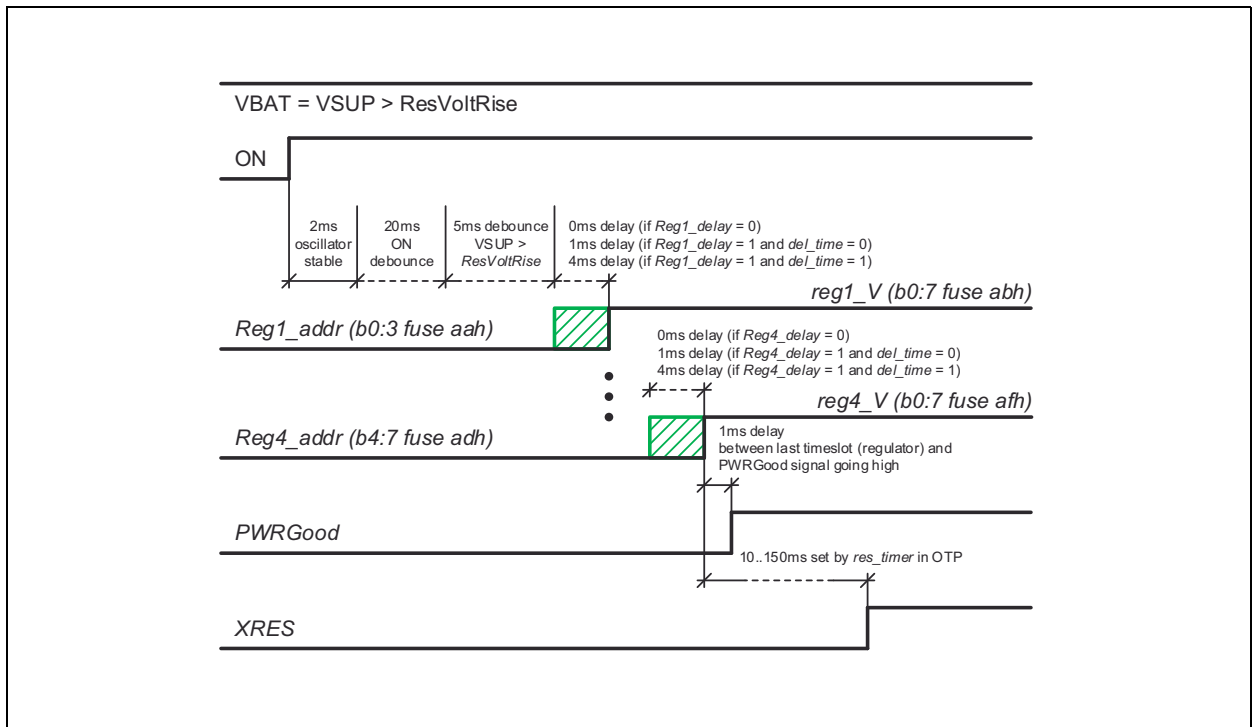

Figure 42:
Start-Up Sequence Diagram 1/5



Start-Up Sequence: This diagram shows the timing of a startup from scratch (battery or charger insertion)

Figure 43:
Start-Up Sequence Diagram 2/5



Start-Up Sequence: This diagram shows the timing of a startup from power-off mode via ON key press (battery connected, VSUP > ResVoltRise)

Figure 44:
Start-Up Sequence Diagram 3/5

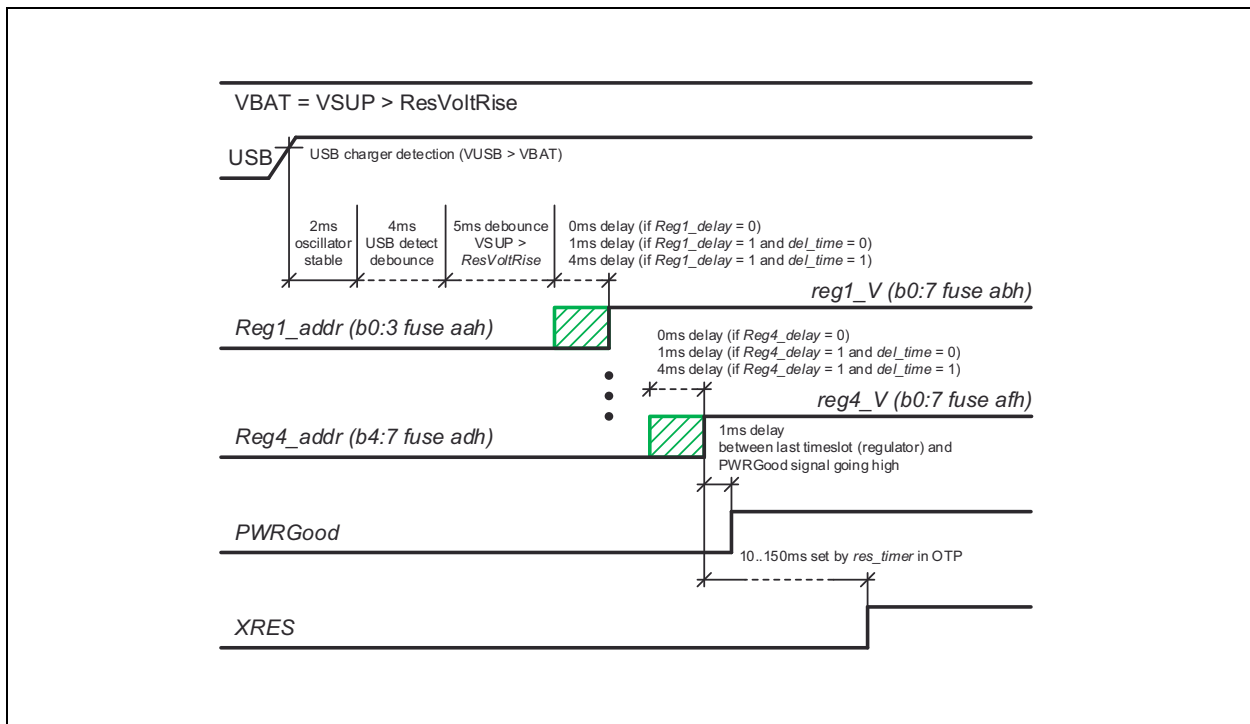

Start-Up Sequence: This diagram shows the timing of a startup from power-off mode via USB charger detection event (battery connected, $VSUP > ResVoltRise$)

Figure 45:
Start-Up Sequence Diagram 4/5

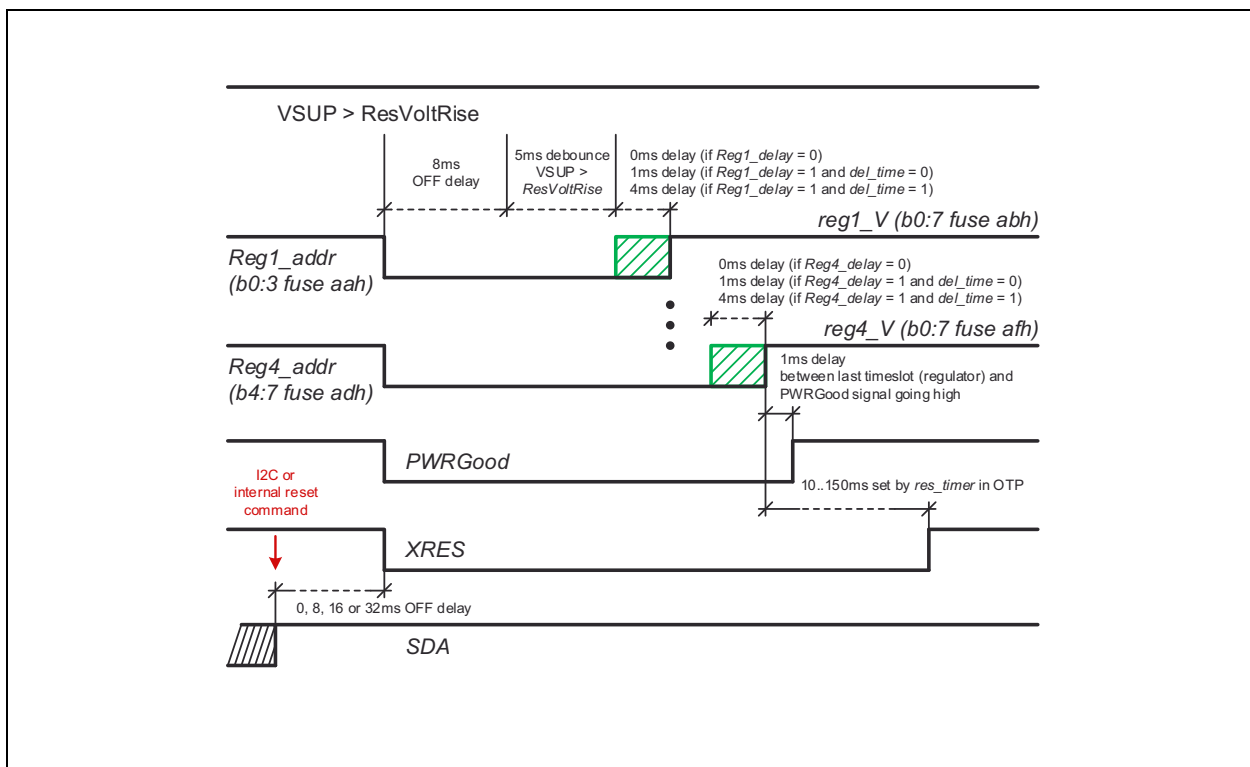

Start-Up Sequence: This diagram shows the timing of a I2C or internal initiated reset command followed by a startup (battery and/or USB charger adapter connected, $VSUP > ResVoltRise$)

Figure 46:
Start-Up Sequence Diagram 5/5

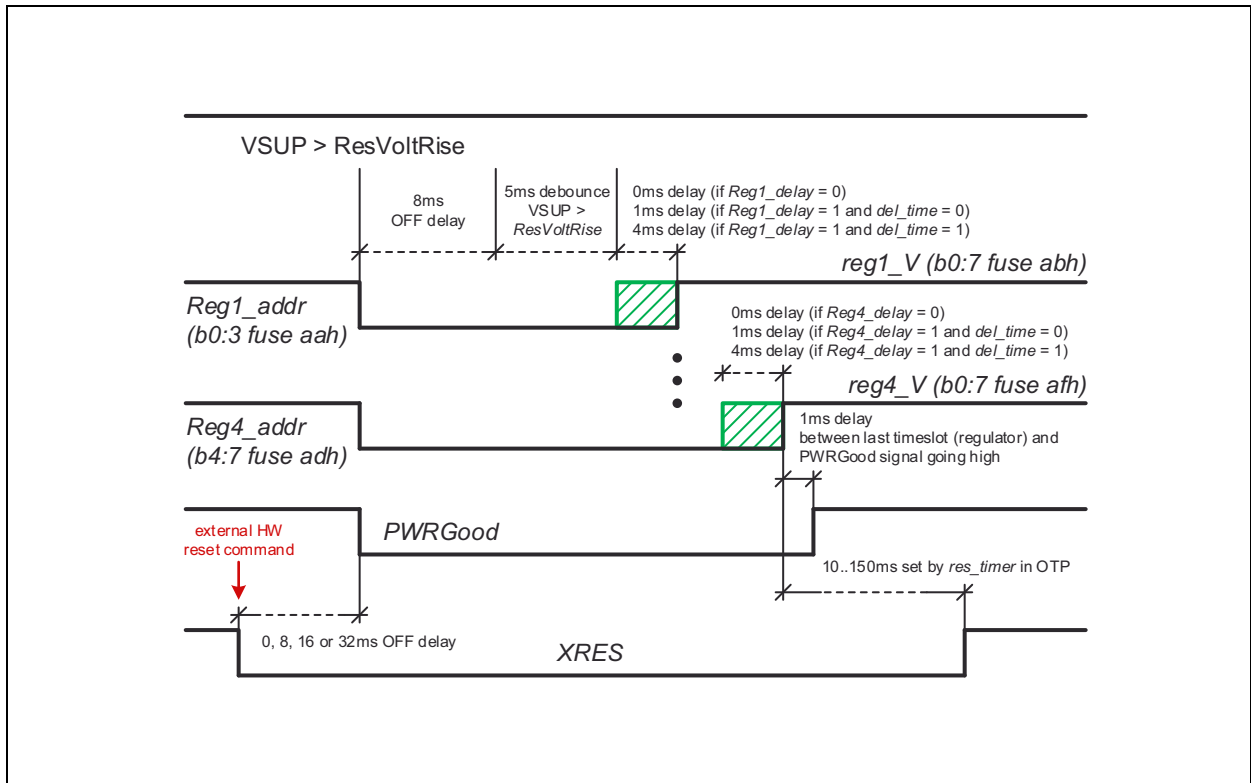

Start-Up Sequence: This diagram shows the timing of an external initiated reset command (forcing XRES to low) followed by a startup (battery and/or USB charger adapter connected, VSUP > ResVoltRise)

Reset

XRES is a low active bi-directional pin. An external pull-up to the peripheral supply has to be added. During each reset cycle the following states are controlled by the AS3701:

- Pin XRES is forced to GND
- Normal startup with programmable power-ON sequence and regulator voltages
- Reset is active until the programmable reset timer (set by res_timer [ResetTimer]) expires
- All registers are set to their default values after power-ON, except the reset control- and status-registers.
- XRES is pulled high by the external resistor and the whole system is leaving the reset state

Note(s): Programming is controlled by the internal Boot-OTP

RESET Reasons

Reset can be activated from the below mentioned different sources:

- VPOR has been reached (VSUP rising from the scratch)
- ResVoltFall was reached (VSUP < ResVoltFall [Battery_voltage_monitor])
- Software forced reset (*force_reset* [ResetControl] = 1)
- XRES is pulled to low
- ON-key long press (on_tast_sw is set to "0")
- Overtemperature

Voltage Detection

A Reset gets initiated, if VSUP rises from scratch and reaches the V_{POR} level. The pin XRES is only released if VSUP is above *ResVoltRise*.

V_{XRES_fall} is only accepted if the reset condition is longer than V_{XRES_mask} . This guard time is used to avoid a complete reset of the system in case of short drops of VSUP.

Figure 47:
Voltage Detection Reset

| SupResEn | <i>power_off_at_vsuplow = 0</i> |
|----------|--|
| 0 | A reset is initiated, if VSUP < 2.7V. If enabled, an interrupt is executed at <i>ResVoltFall</i> . Automatic restart, if VSUP > <i>ResVoltRise</i> . |
| 1 | A reset is initiated, if VSUP < <i>ResVoltFall</i> . Automatic restart, if VSUP > <i>ResVoltRise</i> . |

Software Forced Reset

Writing "1" into the register bit *force_reset* [ResetControl] immediately starts a reset cycle. The bit *force_reset* is automatically cleared by this reset.

External Triggered Reset

If the pin XRES is pulled from high to low by an external source (e.g. microprocessor or button) a reset cycle is started as well.

Long ON-Key Press

For a reset initiated with a long ON-key press, this feature must be enabled by setting the bit *onkey_lpress_en* [ResetControl] to "1". When applying a high level on the ON input pin for 4s/8s (depending on *on_lpress_delay* [ReferenceControl]) a reset gets initiated, if the bit *onkey_lpress_reset* [ReferenceControl] is set to "1". This is thought as a safety feature when the SW hangs up. A long ON key reset is just possible, if the ON key works as a push-button (*on_tast_sw* [ReferenceControl] is set to "0")

Figure 48:
ON-Key Long Press RESET Behavior

| onkey_lpress_en | onkey_lpress_reset | on_lpress_delay | on_tast_sw | Long Press Behavior |
|-----------------|--------------------|-----------------|------------|--|
| 0 | X | X | X | No ON-key long press reset possible |
| 1 | 1 | 0 | 0 | 8s long press on the ON-push-button forces a reset |
| 1 | 1 | 1 | 0 | 4s long press on the ON-push-button forces a reset |
| 1 | 1 | X | 1 | No reset possible, if ON-key works as a switch |

Overtemperature Reset

A reset cycle is getting started, if the overtemperature threshold is reached and the bit *ov_temp_140* [OvertemperatureControl] is set.

Parameter

Figure 49:
XRES Input Characteristics

| Symbol | Parameter | Note | Min | Typ | Max | Unit |
|----------------------|--------------------------|------|-----|-----|-----|------|
| V _{XRES_IL} | RESET low level voltage | | | | 0.4 | V |
| V _{XRES_IH} | RESET high level voltage | | 1.4 | | | V |

Figure 50:
Reset Levels

| Symbol | Parameter | Note | Min | Typ | Max | Unit |
|------------------|---|---|-----|-----------------------------|-----|---------|
| V_{POR} | Overall power on reset | Monitor on VSUP power ON reset for all internal functions | 1.5 | 2.0 | 2.3 | V |
| V_{XRES_rise} | RESET level for V_{SUP} rising | Monitor voltage on VSUP rising level | | ResVolt Rise ⁽¹⁾ | | V |
| V_{XRES_fall} | RESET Level for V_{SUP} falling | Monitor voltage on VSUP falling level | | 2.7 | | V |
| | | if $SupResEn = 1$ only | | ResVolt Fall ⁽²⁾ | | V |
| V_{XRES_mask} | Mask time for V_{XRES_fall} Duration for $V_{BAT} < ResVoltFall$ until a reset cycle is started ⁽³⁾ | $FastResEn = 0$ | | 3 | | ms |
| | | $FastResEn = 1$ | | 64 | | μ s |

Note(s):

1. The selection of the range and level is done via OTP. It's recommended to set the ResVoltRise level 200mV above the ResVoltFall level to have a hysteresis
2. 2.7V is the default value, other levels can be set via SW
3. XRES signal is debounced with the specific mask time for rising- and falling slope of V_{BAT}

Stand-By

Stand-by allows shutting down all rails or just a selected number and can be achieved by one of the following cases:

Enter Via GPIO

To enter the Stand-by mode via GPIO command, the following settings have to be done:

- Enable just these interrupt sources which should lead to leave the stand-by mode
- Make sure that the specified interrupt is inactive (clear the Register *[InterruptStatus]* by register reading)
- Set the *gpioX_mode [GPIOxcontrol]* to input and the *gpioX_iosf [GPIOxcontrol]* should be set to Stand-by + vselect input (*gpioX_iosf = 6*)
- Set *RegX_select [Reg_Control]* and *RegX_voltage [RegX_Voltage]* if another voltage is needed during stand-by for up to 2 regulators
- Define which regulators should be kept powered during Stand-by mode (*sdX_stby_on* and *ldoX_stby_on [Reg_standby_mod1]*)
- Set the *off_delay [Startup_Control]* for going into stand-by after the GPIO command
- Activate the selected GPIO

Enter Via SW

To enter the Stand-by mode via I²C command, the following settings have to be done:

- Enable just these interrupt sources which should lead to leave the stand-by mode
- Make sure that the specified interrupt is inactive (clear the Register *[InterruptStatus]* by register reading)
- Define which regulators should be kept powered during Stand-by mode (*sdX_stby_on* and *ldoX_stby_on [Reg_standby_mod1]*)
- Set the *off_delay [Startup_Control]* for going into stand-by after the I²C command
- Set *standby_mode_on [ReferenceControl]* to 1

During Stand-by all regulators are switched OFF, except those, which are selected either with *RegX_select [Reg_Control]* or with *sdX_stby_on* and *ldoX_stby_on [Reg_standby_mod1]*. XRES goes active (can be disabled with *standby_reset_disable [Startup_Control]*) and *pwr_good* goes inactive. Furthermore, to save power especially in this mode, the internal oscillator is just working, when it is needed.

Leaving Stand-By

Stand-by can be terminated by:

- Any kind of interrupt (if it was defined right before going into Stand-by)
- ON-key push-button press (*on_tast_sw* is set to "0")
- Reset
- Power OFF
- Overtemperature

Power OFF

During power OFF state all circuits are shut-OFF. Thus the current consumption of AS3701 is reduced to about 1µA. Except the reset control registers, all other registers are set to their default value after power-ON.

The chip stays in power OFF mode until

- The external pin ON is pulled high
- The charger is inserted or
- The VPOR level is touched to start a complete reset cycle.

The AS3701 can be set into Power OFF if one of the following conditions occur:

- *ResVoltFall* was reached ($VSUP < ResVoltFall [Battery_voltage_monitor]$)
- Software forced power OFF ($power_off [ResetControl] = 1$)
- ON-key long press
- *auto_off [Startup_Control]* is enabled ($VSUP$ rising from the scratch)

Voltage Detection

If $VSUP$ falls below *ResVoltFall* for longer than 500ms and the bit *power_off_at_vsuplow [Startup_Control]* is set to "1", the PMIC enters the Power Off mode.

Figure 51:
Voltage Detection Power OFF

| SupResEn | <i>power_off_at_vsuplow = 1</i> |
|----------|--|
| 0 | A power-down is initiated, if $VSUP < 2.7V$. If enabled, an interrupt is executed at <i>ResVoltFall</i> . Restart only possible with ON key or charger insertion, if $VSUP > ResVoltRise$. |
| 1 | A power-down is initiated, if $VSUP < ResVoltFall$. Restart only possible with ON key or charger insertion, if $VSUP > ResVoltRise$. |

Software Forced Power OFF

To put the chip into power off mode, write '1' into *power_off [ResetControl]*. In ON-key-switch configuration the AS3701 will startup immediately again, if the switch is in ON position.

The bit *power_off* bit is automatically cleared by a startup and its associated reset cycle.

Long ON-Key Press

For a power OFF asserted with a long ON-key press, this feature must be enabled by setting the bit *onkey_lpress_en* [ResetControl] to "1". When applying a high level on the ON input pin for 4s/8s (depending on *on_lpress_delay* [ReferenceControl]) a power off gets initiated, if the bit *onkey_lpress_reset* [ReferenceControl] is set to "0". A long ON key power off is possible, if the ON key works as a push-button or as a switch.

Figure 52:
ON-Key Long Press Power OFF Behavior

| onkey_lpress_en | onkey_lpress_reset | on_reset_delay | on_tast_sw | Long Press Behavior |
|-----------------|--------------------|----------------|------------|---|
| 0 | X | X | X | No ON-key long press power OFF is possible |
| 1 | 0 | 0 | 0 | 8s long press on the ON-push-button forces a power OFF ⁽¹⁾ |
| 1 | 0 | 1 | 0 | 4s long press on the ON-push-button forces a power OFF ⁽¹⁾ |
| 1 | 0 | 0 | 1 | Forces a power OFF after 8s, if ON-switch is set to OFF position ⁽²⁾ |
| 1 | 0 | 1 | 1 | Forces a power OFF after 4s, if ON-switch is set to OFF position ⁽²⁾ |

Note(s):

1. If a USB charger adapter is connected, the ON-key push-button long press would only force a power-off, if the bit *chg_pwr_off_en* is set to "1"!
2. If a USB charger adapter is connected and the bit *chg_pwr_off_en* is set to "0" (level detection), the ON-key-switch OFF position has no influence. The PMIC will stay in Activemode as long as the USB adapter is present! If a USB adapter is connected and the bit *chg_pwr_off_en* is set to "1" (edge detection), the PMIC can be set into Power-OFF via I²C, if the ON-key switch is also in OFF position!

Auto-OFF

If VSUP is rising from the scratch and the bit *auto_off* [StartupControl] is set to "1", the PMIC enters immediately the Power-OFF mode right after VSUP reaches the *ResVoltRise*. If the ON-key is in switch configuration the Auto-OFF feature only works, when the switch is in OFF position during VSUP rising from scratch!

Internal References

Description

The internal 2.0V reference and the oscillator are powered either via the VUSB input pin or via the VBAT input pin, depending on which level is higher. The internal oscillator is used for PWM, SD frequency and all timings, which are needed for the charger, the startup sequence and reset delays.

Parameter

Figure 53:
Reference Parameter

| Symbol | Parameter | Conditions | Min | Typ | Max | Unit |
|-----------|--------------------------------------|--|-----|-----------|-----|------|
| f_{CLK} | Accuracy of internal reference clock | Adjustable by serial interface register <i>clk_int</i> | -12 | f_{CLK} | +12 | % |

Reference Parameter: Shows the key electrical parameter of the on-chip oscillator

GPIO Pins

AS3701A contains 2 GPIO pins and AS3701B offers 5 GPIO pins. Each of the pins can be configured as digital input, digital input (with pull-up or pull-down), push-pull output or open drain output (with or without pull-up). When configured as output the output source can be a register bit, or the PWM generator.

Additional the GPIO1 and GPIO2 can be configured as a Current sink and the GPIO3 and GPIO4 (only available in AS3701B) can offer an input to connect a NTC for supervising the battery temperature.

The polarity of the input and output signals can be inverted with the corresponding *gpioX_invert* [GPIOXcontrol] bit, all further descriptions refer to normal (non-inverted) mode.

Figure 54:
GPIO Block Diagram

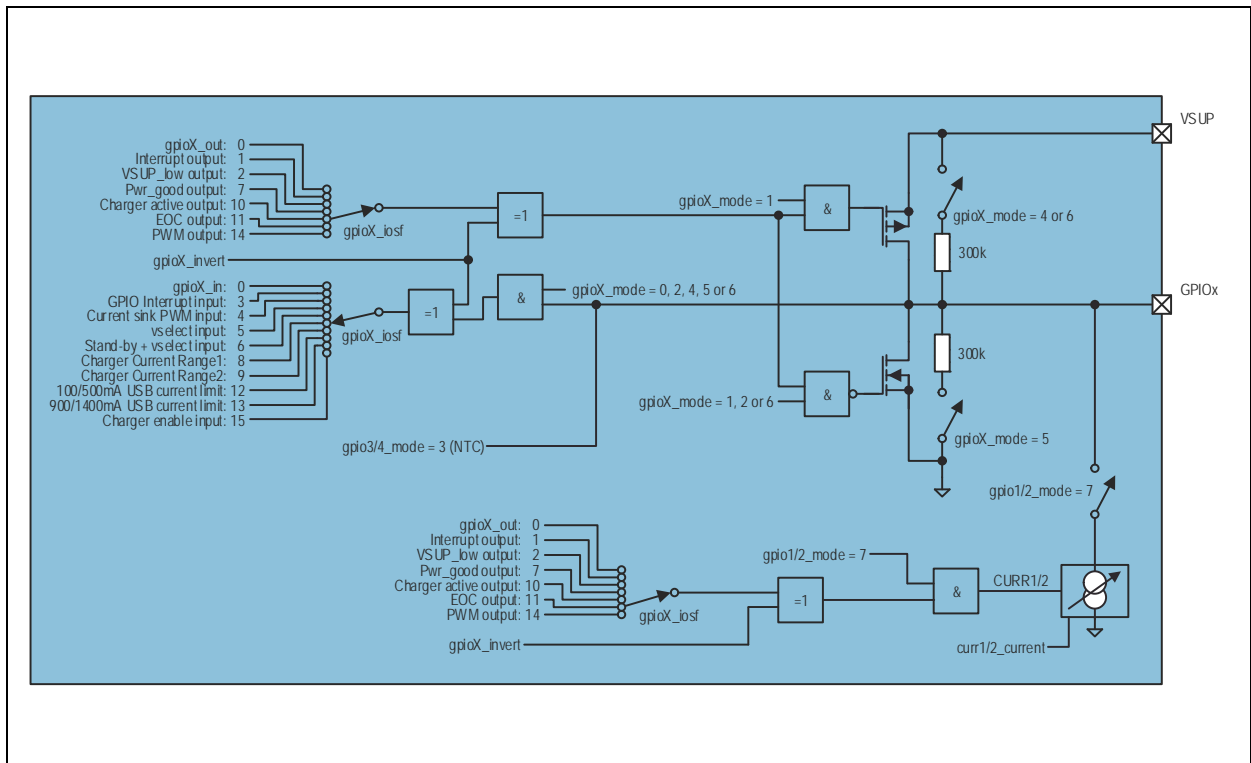

GPIO Block Diagram: Shows the internal structure of the IO pads

Figure 55:
GPIO Pin Characteristics

| Symbol | Parameter | Note | Min | Typ | Max | Unit |
|-----------------|---------------------------|---|-------------|-----|-------------|------------------|
| V_{GPIO_max} | Max voltage on GPIOx pins | Pin VSUP is used as supply for the GPIO pins | | | VSUP + 0.3 | V |
| V_{OL} | Low level output voltage | $I_{OL}=+1\text{mA}$ digital output | | | +0.4 | V |
| V_{OH} | High level output voltage | $I_{OH}=-1\text{mA}$; digital push-pull output | $0.8*VSUP$ | | | V |
| V_{IL} | Low level input voltage | digital input | | | 20% of VSUP | V |
| V_{IH} | High level input voltage | digital input | 60% of VSUP | | | V |
| $I_{LEAKAGE}$ | Leakage current | high impedance | | | 1 | μA |
| $R_{pull-up}$ | Pull-up resistance | if enabled; VSUP = 3.7V | | 300 | | $\text{k}\Omega$ |
| $R_{pull-down}$ | Pull-down resistance | if enabled; VSUP = 3.7V | | 300 | | $\text{k}\Omega$ |

GPIO Pins: Shows the key electrical parameter of the GPIO pins. VSUP = 2.7 to 5.5V; unless otherwise mentioned

IO Functions

Normal IO Operation

If set to input, the logic level of the signal present at the GPIOx pin can be read from *gpioX_in* [GPIOsignal_in]. This mode is also used for the ON/OFF control of the DCDC and LDOs. The selection, which regulator is controlled by which GPIO, is done with the *gpio_ctrl_sdX* [GPIO_ctrl2] or *gpio_ctrl_Idx* [GPIO_ctrl2] bits.

The *gpioX_mode* [GPIOxcontrol] should be set to input.

The *gpioX_iosf* [GPIOxcontrol] should be set to *gpioX_in*.

If the output mode is chosen, *gpioX_out* [GPIOsignal_out] specifies the logic level of the GPIOx pin.

The *gpioX_mode* [GPIOxcontrol] should be set to output.

The *gpioX_iosf* [GPIOxcontrol] should be set to *gpioX_out*.

For GPIO1 and GPIO2, the logic level of the output signal can be visualized via the Current sinks. In this case the *gpioX_mode* [GPIOxcontrol] should be set to CURRx.

Interrupt Output

GPIOx pin logic state is derived from the interrupt signal XIRQ. Whenever an interrupt is present the GPIOx pin will be pulled high.

The *gpioX_mode* [GPIOxcontrol] should be set to output.

The *gpioX_iosf* [GPIOxcontrol] should be set to *Interrupt output*.

For GPIO1 and GPIO2, the Interrupt output signal can be visualized via the Current sinks. In this case the *gpioX_mode* [GPIOxcontrol] should be set to CURRx.

VSUP_low Output

GPIOx pin will go high, if VSUP falls below ResVoltFall and *SupResEn* [Battery_voltage_monitor] = 0.

The *gpioX_mode* [GPIOxcontrol] should be set to output.

The *gpioX_iosf* [GPIOxcontrol] should be set to *VSUP_low output*.

For GPIO1 and GPIO2, the VSUP_low output signal can be visualized via the Current sinks. In this case the *gpioX_mode* [GPIOxcontrol] should be set to CURRx.

PWRGOOD Output

This signal will go high at the end of the start-up sequence. This can be used as a second reset signal to the processor to e.g. start oscillators.

The *gpioX_mode* [GPIOxcontrol] should be set to output.

The *gpioX_iosf* [GPIOxcontrol] should be set to *Pwr_good output*.

For GPIO1 and GPIO2, the Pwr_good output signal can be visualized via the Current sinks. In this case the *gpioX_mode* [GPIOxcontrol] should be set to CURRx.

Charger Active Output

When selected, the GPIOx will go high if the charger is active.

The *gpioX_mode* [GPIOxcontrol] should be set to output.

The *gpioX_iosf* [GPIOxcontrol] should be set to *Charger active output*.

For GPIO1 and GPIO2, the Charger active output signal can be visualized via the Current sinks. In this case the *gpioX_mode* [GPIOxcontrol] should be set to CURRx.

EOC Output

When selected, the GPIOx will go high if the charger has reached the EOC state.

The *gpioX_mode* [GPIOxcontrol] should be set to output.

The *gpioX_iosf* [GPIOxcontrol] should be set to *EOC output*.

For GPIO1 and GPIO2, the EOC output signal can be visualized via the Current sinks. In this case the *gpioX_mode* [GPIOxcontrol] should be set to CURRx.

PWM Output

When selected, the GPIOx output provides the PWM signal generated by the internal programmable PWM generator. Its timing is defined by *pwm_h_time* [*pwm_control_h*], *pwm_l_time* [*pwm_control_l*] and *pwm_div* [*ReferenceControl*].

The *gpioX_mode* [*GPIOxcontrol*] should be set to output.

The *gpioX_iosf* [*GPIOxcontrol*] should be set to *PWM output*.

For GPIO1 and GPIO2, the PWM output signal can be visualized via the Current sinks. In this case the *gpioX_mode* [*GPIOxcontrol*] should be set to *CURRx*.

GPIO Interrupt Input

A falling or rising edge will set the *gpio_int* bit.

The *gpioX_mode* [*GPIOxcontrol*] should be set to input.

The *gpioX_iosf* [*GPIOxcontrol*] should be set to *GPIO Interrupt input*.

Current Sink PWM Input

The GPIO is used as PWM input for the current sink to control the current. 100% PMW mode will set the current to the value set in *currX_current* [*currX_value*] register.

The *gpioX_mode* [*GPIOxcontrol*] should be set to input.

The *gpioX_iosf* [*GPIOxcontrol*] should be set to *Current sink PWM input*.

Vselect Input

As long as the GPIOx pin is low the DCDC/LDOs operate with the normal register settings. If the GPIOx pin goes high, the settings will change to the ones stored in *RegX_voltage* [*RegX_Voltage*].

The *gpioX_mode* [*GPIOxcontrol*] should be set to input.

The *gpioX_iosf* [*GPIOxcontrol*] should be set to *vselect input*.

GPIO1 and GPIO2 may be used to control two regulators separately.

Figure 56:
GPIO Vselect Modes

| gpio1_ iosf | gpio2_ iosf | gpio3_ iosf | gpio4_ iosf | gpio5_ iosf | Vselect Mode |
|----------------|----------------|----------------|----------------|----------------|--|
| ≠5 | ≠5 | ≠5 | ≠5 | ≠5 | No voltage select by GPIO for regulator |
| 5 | ≠5 | ≠5 | ≠5 | ≠5 | GPIO1 controls regulator selected by <i>reg1_select</i> and <i>reg2_select</i> |
| ≠5 | 5 | ≠5 | ≠5 | ≠5 | GPIO2 controls regulator selected by <i>reg1_select</i> and <i>reg2_select</i> |
| 5 | 5 | ≠5 | ≠5 | ≠5 | GPIO1 controls regulator selected by <i>reg1_select</i> GPIO2 controls regulator selected by <i>reg2_select</i> |

| gpio1_iosf | gpio2_iosf | gpio3_iosf | gpio4_iosf | gpio5_iosf | Vselect Mode |
|------------|------------|------------|------------|------------|---|
| ≠5 | ≠5 | 5 | ≠5 | ≠5 | GPIO3 controls regulator selected by <i>reg1_select</i> and <i>reg2_select</i> ⁽¹⁾ |
| ≠5 | ≠5 | ≠5 | 5 | ≠5 | GPIO4 controls regulator selected by <i>reg1_select</i> and <i>reg2_select</i> ⁽¹⁾ |
| ≠5 | ≠5 | ≠5 | ≠5 | 5 | GPIO5 controls regulator selected by <i>reg1_select</i> and <i>reg2_select</i> ⁽¹⁾ |

IO Functions: Shows the different Vselect control modes, depending on the setting of the GPIO special function 5.

Note(s):

1. AS3701B only

Stand-By and Vselect Input

This mode is very similar to the Vselect mode described in the previous paragraph. The chip is set into stand-by mode when the GPIOx pin goes high and wakes up again when the pin is pulled low and the *gpio_restart_int_m* [InterruptMask2] has been set before going into stand-by. Additional to the stand-by feature, the voltage setting of 2 regulators can be changed with the same command. This requires the setting of the corresponding regulator (*sd1_stby_on* and/or *ldo1_stby_on* and/or *ldo2_stby_on* [Reg_standby_mod1]).

The *gpioX_mode* [GPIOxcontrol] should be set to input.

The *gpioX_iosf* [GPIOxcontrol] should be set to Stand-by + vselect input.

Figure 57:
Stand-By and Vselect Modes

| gpio1_iosf | gpio2_iosf | gpio3_iosf | gpio4_iosf | gpio5_iosf | Vselect Mode | Stand-By Control |
|------------|------------|------------|------------|------------|---|------------------|
| ≠6 | ≠6 | ≠6 | ≠6 | ≠6 | No voltage select by GPIO for regulator | No |
| 6 | ≠6 | ≠6 | ≠6 | ≠6 | GPIO1 controls regulator selected by <i>reg1_select</i> and <i>reg2_select</i> | Yes |
| ≠6 | 6 | ≠6 | ≠6 | ≠6 | GPIO2 controls regulator selected by <i>reg1_select</i> and <i>reg2_select</i> | Yes |
| ≠6 | ≠6 | 6 | ≠6 | ≠6 | GPIO3 controls regulator selected by <i>reg1_select</i> and <i>reg2_select</i> ⁽¹⁾ | Yes |
| ≠6 | ≠6 | ≠6 | 6 | ≠6 | GPIO4 controls regulator selected by <i>reg1_select</i> and <i>reg2_select</i> ⁽¹⁾ | Yes |
| ≠6 | ≠6 | ≠6 | ≠6 | 6 | GPIO5 controls regulator selected by <i>reg1_select</i> and <i>reg2_select</i> ⁽¹⁾ | Yes |

IO Functions: Shows the different Vselect and stand-by control modes, depending on the setting of the GPIO special function 6.

Note(s):

1. AS3701B only

Charger Current Range 1

With this function the charging current (trickle current and constant current) can be set to 11mA(trickle) + 133mA(constant) or 22mA(trickle) + 223mA(constant). The *gpioX_mode* [*GPIOxcontrol*] should be set to input. The *gpioX_iosf* [*GPIOxcontrol*] should be set to *Charger Current Range1*.

Charger Current Range 2

With this function the charging current (trickle current and constant current) can be set to 33mA(trickle) + 357mA(constant) or 45mA(trickle) + 493mA(constant). The *gpioX_mode* [*GPIOxcontrol*] should be set to input. The *gpioX_iosf* [*GPIOxcontrol*] should be set to *Charger Current Range2*.

100/500mA Charger Input

With this function the charger input current limiter can be set to 100mA or 500mA. The *gpioX_mode* [*GPIOxcontrol*] should be set to input. The *gpioX_iosf* [*GPIOxcontrol*] should be set to *100/500mA USB current limit*.

800/1100mA Charger Input

With this function the charger input current limiter can be set to 800mA or 1100mA.

The *gpioX_mode [GPIOxcontrol]* should be set to input.

The *gpioX_iosf [GPIOxcontrol]* should be set to 800/1100mA USB current limit.

Charging Enable Input

When pulling the GPIO to high the charger is being enabled and vice versa. This is to enable the charger without I²C communication.

The *gpioX_mode [GPIOxcontrol]* should be set to input.

The *gpioX_iosf [GPIOxcontrol]* should be set to *Charger enable input*.

Supervisor

The Step Down DCDC Converter has an integrated overcurrent protection. An overtemperature protection of the chip is also integrated which can be switched ON with the serial interface signal *temp_pmc_on [OvertemperatureControl]* (enabled by default; it is not recommended to disable the overtemperature protection).

Temperature Supervision

The chip has two signals for the serial interface: *ov_temp_110* and *ov_temp_140 [OvertemperatureControl]*.

The flag *ov_temp_110* is automatically reset if the overtemperature condition is removed, whereas *ov_temp_140* has to be reset by the serial interface with the signal *rst_ov_temp_140 [OvertemperatureControl]*. If the flag *ov_temp_140* is set, an automatic reset of the complete chip is initiated. The chip will only start-up when the temperature falls below the T₁₁₀ level (including hysteresis). The flag *ov_temp_140* is not affected by this reset cycle allowing the software to detect the reason for this unexpected shutdown.

Figure 58:
Overtemperature Protection

| Symbol | Parameter | Note | Min | Typ | Max | Unit |
|-------------------|--|------|-----|-----|-----|------|
| T ₁₁₀ | ov_temp_110 rising threshold | | 95 | 110 | 125 | °C |
| T ₁₄₀ | ov_temp_140 rising threshold | | 125 | 140 | 155 | °C |
| T _{HYST} | ov_temp_110 and ov_temp_140 hysteresis | | | 5 | | °C |

Interrupt Generation

The interrupt controller generates an interrupt request for the host controller as soon as one or more of the bits in the InterruptMask registers are set by pulling low the pin XIRQ. All the interrupt sources can be enabled in the Interrupt Mask registers. If an interrupt occurs, the Interrupt Status registers get set and cleared automatically after the host controller has read them.

To prevent the AS3701 device from losing an interrupt event, the register that is read is captured before it is transmitted to the host controller via the serial interface. As soon as the transmission of the captured value is completed, a logical AND operation with the bit wise inverted captured value is applied to the register to clear all interrupt bits that have already been transmitted. Clearing the read interrupt bits takes 2 clock cycles, a read access to the same register, before the clearing process has completed, will yield a value of '0'. Note that an interrupt that has been present at the previous read access will be cleared as well in case it occurs again before the clearing process has completed.

Wire-Serial Control Interface

Feature List

- Fast-mode capability (max. SCL-frequency is 400 kHz)
- 7+1-bit addressing mode
- 60h x 8-bit data registers (word address 0x00 - 0x60)
- Write formats: Single-Byte-Write, Page-Write
- Read formats: Current-Address-Read, Random-Read, Sequential-Read
- SDA input delay and SCL spike filtering by integrated RC-components

I²C Protocol

Figure 59:
I²C Symbol Definition

| Symbol | Definition | RW | Note |
|----------|-----------------------------------|----|--------------------|
| S | Start condition after Stop | R | 1 bit |
| Sr | Repeated Start | R | 1 bit |
| DW | Device address for Write | R | 1000 0000b (80h) |
| DR | Device address for Read | R | 1000 0001b (81h) |
| WA | Word address | R | 8 bit |
| A | Acknowledge | W | 1 bit |
| N | No Acknowledge | R | 1 bit |
| reg_data | Register data/write | R | 8 bit |
| data (n) | Register data/read | W | 8 bit |
| P | Stop condition | R | 1 bit |
| WA++ | Increment word address internally | R | During acknowledge |

I²C Write Access

Byte Write and Page Write formats are used to write data to the slave.

Figure 60:
I²C Byte Write

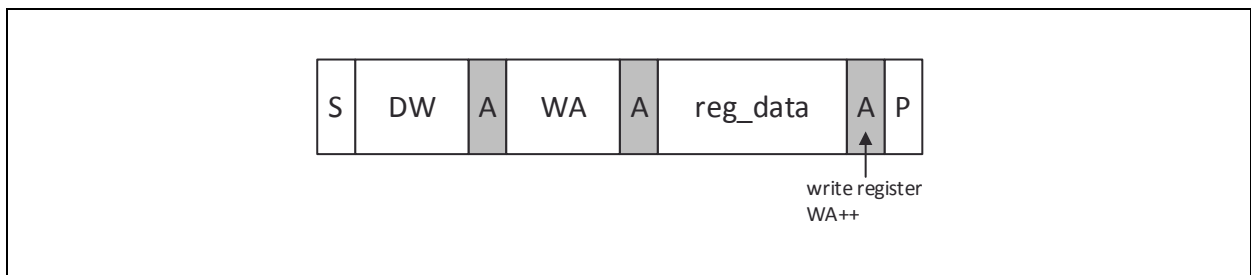
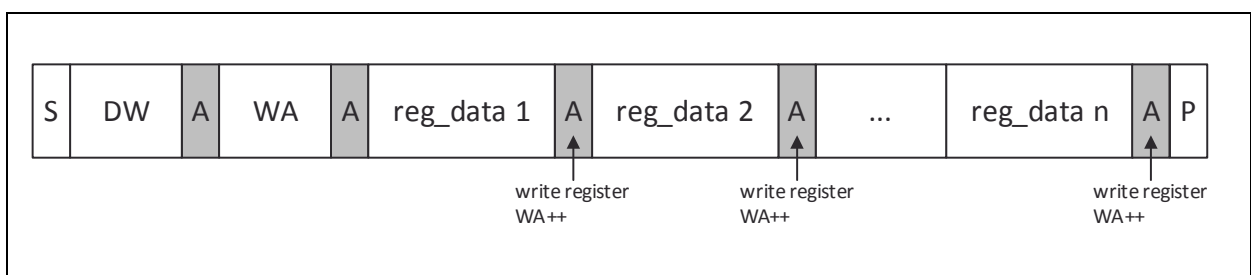

Figure 61:
I²C Page Write



The transmission begins with the START condition, which is generated by the master when the bus is in IDLE state (the bus is free). The device-write address is followed by the word address. After the word address any number of data bytes can be sent to the slave. The word address is incremented internally, in order to write subsequent data bytes on subsequent address locations.

For reading data from the slave device, the master has to change the transfer direction. This can be done either with a repeated START condition followed by the device-read address, or simply with a new transmission START followed by the device-read address, when the bus is in IDLE state. The device-read address is always followed by the 1st register byte transmitted from the slave. In Read Mode any number of subsequent register bytes can be read from the slave. The word address is incremented internally.

I²C Read Access

Random, Sequential and Current Address Read are used to read data from the slave.

Figure 62:
I²C Random Read

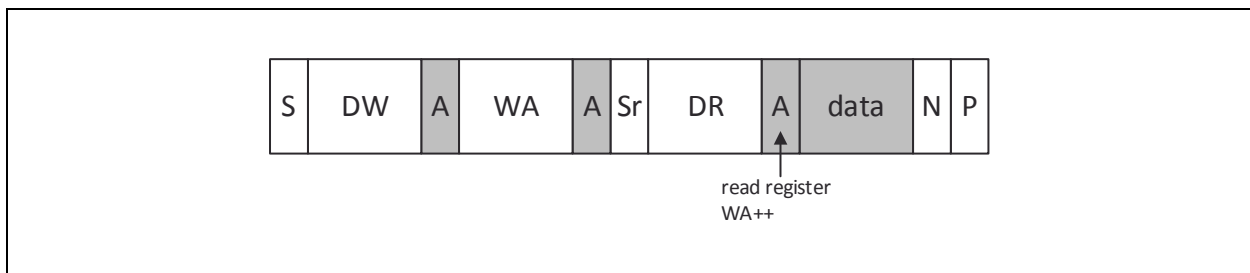

Random Read and Sequential Read are combined formats. The repeated START condition is used to change the direction after the data transfer from the master.

The word address transfer is initiated with a START condition issued by the master while the bus is idle. The START condition is followed by the device-write address and the word address.

In order to change the data direction a repeated START condition is issued on the 1st SCL pulse after the acknowledge bit of the word address transfer. After the reception of the device-read address, the slave becomes the transmitter. In this state the slave transmits register data located by the previous received word address vector. The master responds to the data byte with a not-acknowledge, and issues a STOP condition on the bus.

Figure 63:
I²C Sequential Read

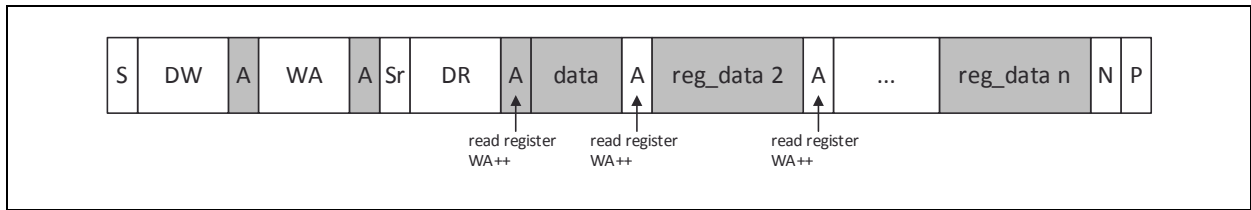

Sequential Read is the extended form of Random Read, as more than one register-data bytes are transferred subsequently. In difference to the Random Read, for a sequential read the transferred register-data bytes are responded by an acknowledge from the master. The number of data bytes transferred in one sequence is unlimited (consider the behavior of the word-address counter). To terminate the transmission the master has to send a not-acknowledge following the last data byte and generate the STOP condition subsequently.

Figure 64:
I²C Current Address Read

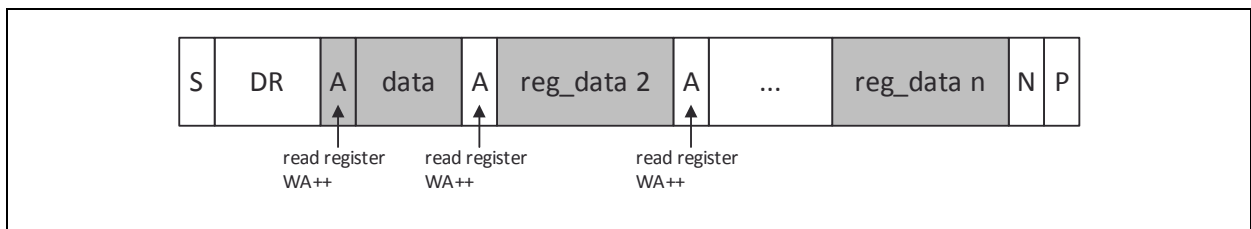

To keep the access time as small as possible, this format allows a read access without the word address transfer in advance to the data transfer. The bus is idle and the master issues a START condition followed by the Device-Read address. Analogous to Random Read, a single byte transfer is terminated with a not-acknowledge after the 1st register byte. Analogous to Sequential Read an unlimited number of data bytes can be transferred, where the data bytes has to be responded with an acknowledge from the master. For termination of the transmission the master sends a not-acknowledge following the last data byte and a subsequent STOP condition.

I²C Parameter

Figure 65:
I²C Characteristics

| Symbol | Parameter | Condition | Min | Typ | Max | Unit |
|-----------------|----------------------------------|-----------|-----|-----|-----|------|
| V _{IL} | SCL,SDA Low Level input voltage | | | | 0.4 | V |
| V _{IH} | SCL,SDA High Level input voltage | | 1.6 | | | V |

Register Description

Figure 66:
Register Overview

| Addr | Name | D7 | D6 | D5 | D4 | D3 | D |
|------|----------------|--------------|---------------------|------------------|-----------|-----------|-------|
| 01h | SD1Voltage | sd1_frequ | sd1_vsel<6:0> | | | | |
| 02h | LDO1Voltage | ldo1_on | ldo1_ilimit | ldo1_vsel<5:0> | | | |
| 03h | LDO2Voltage | ldo2_on | ldo2_ilimit | ldo2_vsel<5:0> | | | |
| 09h | GPIO1control | gpio1_invert | gpio1_mode<6:4> | | | | |
| 0ah | GPIO2control | gpio2_invert | gpio2_mode<6:4> | | | | |
| 0bh | GPIO3control | gpio3_invert | gpio3_mode<6:4> | | | | |
| 0ch | GPIO4control | gpio4_invert | gpio4_mode<6:4> | | | | |
| 0dh | GPIO5control | gpio5_invert | gpio5_mode<6:4> | | | | |
| 20h | GPIOsignal_out | - | - | gpio5_out | gpio5_out | gpio4_out | gpio3 |
| 21h | GPIOsignal_in | - | - | gpio5_in | gpio5_in | gpio4_in | gpio |
| 22h | Reg1_Voltage | - | Reg1_voltage<6:0> | | | | |
| 23h | Reg2_Voltage | - | Reg2_voltage<6:0> | | | | |
| 24h | Reg_Control | - | - | Reg2_select<5:4> | | - | - |
| 25h | GPIO_ctrl1 | - | gpio_ctrl_ldo2<6:4> | | | | |
| 26h | GPIO_ctrl2 | - | | | | | |
| 30h | SD_control1 | sd1_enable | sd1_low_noise | sd1_fast | sd1_fsel | - | - |

| Addr | Name | D7 | D6 | D5 | D4 | D3 | D |
|------|-------------------------|--------------------|----------------------|--------------------|-----------------|----------------|--------------|
| 32h | Battery_voltage_monitor | FastResEn | SupResEn | ResVoltFall<5:3> | | | |
| 33h | Startup_control | chg_pwr_off_en | power_off_at_vsuplow | stby_reset_disable | auto_off | off_delay<3:2> | |
| 35h | ReferenceControl | on_lpress_delay | on_tast_sw | onkey_lpress_reset | standby_mode_on | clk_int<3:2> | |
| 36h | ResetControl | reset_reason<7:4> | | | | | |
| 37h | Overtemperature Control | tco_140_a | tco_110_a | temp_test<5:4> | | | |
| 39h | Reg_standby_mod1 | - | | | | | |
| 41h | pwm_control_l | pwm_l_time<7:0> | | | | | |
| 42h | pwm_control_h | pwm_h_time<7:0> | | | | | |
| 43h | curr1_value | curr1_current<7:0> | | | | | |
| 44h | curr2_value | curr2_current<7:0> | | | | | |
| 73h | RegStatus | - | curr2_lv | curr1_lv | - | | |
| 74h | InterruptMask1 | LowBat_int_m | ovtmp_int_m | onkey_int_m | chdet_int_m | eoc_int_m | resume_int_m |
| 75h | InterruptMask2 | gpio5_int_m | gpio4_int_m | gpio3_int_m | gpio2_int_m | gpio1_int_m | gpio_re_int |
| 77h | InterruptStatus1 | LowBat_int_i | ovtmp_int_i | onkey_int_i | chdet_int_i | eoc_int_i | resume_int |
| 78h | InterruptStatus2 | gpio5_int_i | gpio4_int_i | gpio3_int_i | gpio2_int_i | gpio1_int_i | gpio_re_int |

| Addr | Name | D7 | D6 | D5 | D4 | D3 | D | |
|------|-----------------------|---------------------|----------------|---------------------|---------------|-----|----------------|--------|
| 80h | ChargerControl | cc_range_select | AutoResume | bat_charging_enable | usb_chgEn | | | |
| 81h | ChargerVoltageControl | Vsup_min<7:6> | | - | | | ChVoltEC | |
| 82h | ChargerCurrentControl | TrickleCurrent<7:4> | | | | | | Co |
| 83h | ChargerConfig1 | Charging_1Hz_clk | ChVoltResume | temp_sel<5:4> | | | vsup_volt | |
| 84h | ChargerConfig2 | eoc_current<7:5> | | | charging_tmax | | | |
| 85h | Chargersupervision | ntc_high_on | ntc_low_on | ntc_10k | ntc_mode | | NTC_input<3:2> | |
| 86h | ChargerStatus1 | NoBat | temp_cond<6:5> | | EOC | CVM | Tric | |
| 87h | ChargerStatus2 | - | | | | | chdet_off | Ch |
| 8eh | LockRegister | - | | | | | - | charge |
| 90h | ASIC_ID1 | - | | | | | ID1<7:0> | |
| 91h | ASIC_ID2 | - | | | | | | |
| a5h | Fuse5 | del_time | sequ_on | | | | | |
| a6h | Fuse6 | | | | | | | on_ta |

| Addr | Name | D7 | D6 | D5 | D4 | D3 | D | |
|------|--------|------------------|----------------|----------------|----------|----------|---------------|----------|
| a7h | Fuse7 | auto_off | chg_pwr_off_en | res_timer<5;4> | | sd1_fsel | sd1_ | |
| a8h | Fuse8 | usb_current<7;4> | | | | | | ResVoltR |
| a9h | Fuse9 | Reg4_del | Reg3_del | Reg2_del | Reg1_del | SupResEn | onk lpress | |
| aa | Fuse10 | Reg2_addr<7;4> | | | | | | |
| abh | Fuse11 | reg1_V<7:0> | | | | | | |
| ach | Fuse12 | reg2_V<7:0> | | | | | | |
| adh | Fuse13 | Reg4_addr<7;4> | | | | | | |
| aeh | Fuse14 | reg3_V<7:0> | | | | | | |
| afh | Fuse15 | reg4_V<7:0> | | | | | | |

Detailed Register Description

Figure 67:
SD1Voltage

| Addr:01h | | SD1Voltage | | |
|----------|-----------|------------|--------|---|
| Bit | Bit Name | Default | Access | Bit Description |
| 7 | sd1_frequ | b0 | RW | Selects between high and low frequency 0 : 1 MHz if sd1_fsel=0, 2MHz if sd1_fsel=1 1 : 3 MHz if sd1_fsel=0, 4MHz if sd1_fsel=1 |
| 6:0 | sd1_vsel | b0000000 | RW | The voltage select bits set the DC/DC output voltage level and power the DC/DC converter down. 00h : DC/DC powered down 01h-40h : $V_{SD1}=0.6V+sd1_vsel*12.5mV$ 41h-70h : $V_{SD1}=1.4V+(sd1_vsel-40h)*25mV$ 71h-7Fh : $V_{SD1}=2.6V+(sd1_vsel-70h)*50mV$ |

Figure 68:
LDO1Voltage

| Addr:02h | | LDO1Voltage | | |
|----------|-------------|-------------|--------|---|
| Bit | Bit Name | Default | Access | Bit Description |
| 7 | ldo1_on | b0 | RW | Switch ON of LDO1 0 : LDO OFF 1 : LDO ON |
| 6 | ldo1_ilimit | b0 | RW | Sets current limit of LDO1 0 : 100mA operating range 1 : 200mA operating range |
| 5:0 | ldo1_vsel | b000000 | RW | The voltage select bits set the LDO output voltage 00h-2Ah : $V_{LDO1}=1.2V+ldo1_vsel*50mV$ 2Bh-3Fh : Do not use |

Figure 69:
LDO2Voltage

| Addr:03h | | LDO2Voltage | | |
|----------|-------------|-------------|--------|--|
| Bit | Bit Name | Default | Access | Bit Description |
| 7 | ldo2_on | b0 | RW | Switch ON of LDO2 0 : LDO OFF 1 : LDO ON |
| 6 | ldo2_ilimit | b0 | RW | Sets current limit of LDO2 0 : 100mA operating range 1 : 200mA operating range |
| 5:0 | ldo2_vsel | b000000 | RW | The voltage select bits set the LDO output voltage 00h-2Ah : $V_LDO2=1.2V+ldo2_vsel*50mV$ 2Bh-3Fh : Do not use |

Figure 70:
GPIO1control

| Addr:09h | | GPIO1control | | | |
|----------|--------------|--------------|--------|---|--|
| Bit | Bit Name | Default | Access | Bit Description | |
| 7 | gpio1_invert | b0 | RW | Invert GPIO1 input/output 0 : Normal Mode 1 : Invert input or output | |
| 6:4 | gpio1_mode | b011 | RW | Selects the GPIO1 mode (I, I/O, Tri, Pulls) 0 : Input 1 : Output (push and pull) 2 : IO(open drain, only NMOS is active) 3 : Input (tristate) 4 : Input with pullup 5 : Input with pulldown 6 : IO(open drain(NMOS)with pullup) 7 : CURR1 | |
| 3:0 | gpio1_iosf | b0000 | RW | Selects the GPIO1 special function 0 : Normal I/O operation 1 : Interrupt output 2 : VSUP_low output 3 : GPIO interrupt input 4 : Current sink PWM input 5 : Vselect input, (apply on reg1_select and reg2_select, if gpio2_iosf=5 then apply on reg1_select only) 6 : standby+Vselect+restart interrupt input 7 : pwr_good output 8 : 11mA(TrickleCurrent=0), 133mA(ConstantCurrent=2) / 23mA(TrickleCurrent=1), 223mA(ConstantCurrent=4) 9 : 35mA(TrickleCurrent=2), 358mA(ConstantCurrent=7) / 47mA(TrickleCurrent=3), 494mA(ConstantCurrent=10) 10 : Charger active output 11 : EOC output 12 : 100mA(usb_Current=0) / 500mA(usb_Current=8) 13 : 800mA(usb_Current=11) / 1100mA(usb_Current=13) 14 : PWM output 15 : Charger enable input | |

Figure 71:
GPIO2control

| Addr:0ah | | GPIO2control | | |
|----------|--------------|--------------|--------|---|
| Bit | Bit Name | Default | Access | Bit Description |
| 7 | gpio2_invert | b0 | RW | Invert GPIO2 input/output 0 : Normal Mode 1 : Invert input or output |
| 6:4 | gpio2_mode | b011 | RW | Selects the GPIO2 mode (I, I/O, Tri, Pulls) 0 : Input 1 : Output (push and pull) 2 : IO(open drain, only NMOS is active) 3 : Input (tristate) 4 : Input with pullup 5 : Input with pulldown 6 : IO(open drain(NMOS)with pullup) 7 : CURR2 |
| 3:0 | gpio2_iosf | b0000 | RW | Selects the GPIO2 special function 0 : Normal I/O operation 1 : Interrupt output 2 : VSUP_low output 3 : GPIO interrupt input 4 : Current sink PWM input 5 : Vselect input, (apply on reg1_select and reg2_select, if gpio1_iosf=5 then apply on reg2_select only) 6 : standby+Vselect+restart interrupt input 7 : pwr_good output 8 : 11mA(TrickleCurrent=0), 133mA(ConstantCurrent=2) / 23mA(TrickleCurrent=1), 223mA(ConstantCurrent=4) 9 : 35mA(TrickleCurrent=2), 358mA(ConstantCurrent=7) / 47mA(TrickleCurrent=3), 494mA(ConstantCurrent=10) 10 : Charger active output 11 : EOC output 12 : 100mA(usb_Current=0) / 500mA(usb_Current=8) 13 : 800mA(usb_Current=11) / 1100mA(usb_Current=13) 14 : PWM output 15 : Charger enable input |

Figure 72:
GPIO3control

| Addr:0bh | | GPIO3control | | |
|----------|--------------|--------------|--------|---|
| Bit | Bit Name | Default | Access | Bit Description |
| 7 | gpio3_invert | b0 | RW | Invert GPIO3 input/output 0 : Normal Mode 1 : Invert input or output |
| 6:4 | gpio3_mode | b011 | RW | Selects the GPIO3 mode (I, I/O, Tri, Pulls) 0 : Input 1 : Output (push and pull) 2 : IO(open drain, only NMOS is active) 3 : NTC input (tristate) 4 : Input with pullup 5 : Input with pulldown 6 : IO(open drain(NMOS)with pullup) 7 : NA |
| 3:0 | gpio3_iosf | b0000 | RW | Selects the GPIO3 special function 0 : Normal I/O operation 1 : Interrupt output 2 : VSUP_low output 3 : GPIO interrupt input 4 : Current sink PWM input 5 : Vselect input, (apply on reg1_select and reg2_select) 6 : standby+Vselect+restart interrupt input 7 : pwr_good output 8 : 11mA(TrickleCurrent=0), 133mA(ConstantCurrent=2) / 23mA(TrickleCurrent=1), 223mA(ConstantCurrent=4) 9 : 35mA(TrickleCurrent=2), 358mA(ConstantCurrent=7) / 47mA(TrickleCurrent=3), 494mA(ConstantCurrent=10) 10 : Charger active output 11 : EOC output 12 : 100mA(usb_Current=0) / 500mA(usb_Current=8) 13 : 800mA(usb_Current=11) / 1100mA(usb_Current=13) 14 : PWM output 15 : Charger enable input |

Figure 73:
GPIO4control

| Addr:0ch | | GPIO4control | | |
|----------|--------------|--------------|--------|---|
| Bit | Bit Name | Default | Access | Bit Description |
| 7 | gpio4_invert | b0 | RW | Invert GPIO4 input/output 0 : Normal Mode 1 : Invert input or output |
| 6:4 | gpio4_mode | b011 | RW | Selects the GPIO4 mode (I, I/O, Tri, Pulls) 0 : Input 1 : Output (push and pull) 2 : IO(open drain, only NMOS is active) 3 : NTC input (tristate) 4 : Input with pullup 5 : Input with pulldown 6 : IO(open drain(NMOS)with pullup) 7 : NA |
| 3:0 | gpio4_iosf | b0000 | RW | Selects the GPIO4 special function 0 : Normal I/O operation 1 : Interrupt output 2 : VSUP_low output 3 : GPIO interrupt input 4 : Current sink PWM input 5 : Vselect input, (apply on reg1_select and reg2_select) 6 : standby+Vselect+restart interrupt input 7 : pwr_good output 8 : 11mA(TrickleCurrent=0), 133mA(ConstantCurrent=2) / 23mA(TrickleCurrent=1), 223mA(ConstantCurrent=4) 9 : 35mA(TrickleCurrent=2), 358mA(ConstantCurrent=7) / 47mA(TrickleCurrent=3), 494mA(ConstantCurrent=10) 10 : Charger active output 11 : EOC output 12 : 100mA(usb_Current=0) / 500mA(usb_Current=8) 13 : 800mA(usb_Current=11) / 1100mA(usb_Current=13) 14 : PWM output 15 : Charger enable input |

Figure 74:
GPIO5control

| Addr:0dh | | GPIO5control | | |
|----------|--------------|--------------|--------|---|
| Bit | Bit Name | Default | Access | Bit Description |
| 7 | gpio5_invert | b0 | RW | Invert GPIO5 input/output 0 : Normal Mode 1 : Invert input or output |
| 6:4 | gpio5_mode | b011 | RW | Selects the GPIO5 mode (I, I/O, Tri, Pulls) 0 : Input 1 : Output (push and pull) 2 : IO(open drain, only NMOS is active) 3 : Input (tristate) 4 : Input with pullup 5 : Input with pulldown 6 : IO(open drain(NMOS)with pullup) 7 : NA |
| 3:0 | gpio5_iosf | b0000 | RW | Selects the GPIO5 special function 0 : Normal I/O operation 1 : Interrupt output 2 : VSUP_low output 3 : GPIO interrupt input 4 : Current sink PWM input 5 : Vselect input, (apply on reg1_select and reg2_select) 6 : standby+Vselect+restart interrupt input 7 : pwr_good output 8 : 11mA(TrickleCurrent=0), 133mA(ConstantCurrent=2) / 23mA(TrickleCurrent=1), 223mA(ConstantCurrent=4) 9 : 35mA(TrickleCurrent=2), 358mA(ConstantCurrent=7) / 47mA(TrickleCurrent=3), 494mA(ConstantCurrent=10) 10 : Charger active output 11 : EOC output 12 : 100mA(usb_Current=0) / 500mA(usb_Current=8) 13 : 800mA(usb_Current=11) / 1100mA(usb_Current=13) 14 : PWM output 15 : Charger enable input |

Figure 75:
GPIOsignal_out

| Addr:20h | | GPIOsignal_out | | |
|----------|-----------|----------------|--------|--|
| Bit | Bit Name | Default | Access | Bit Description |
| 4 | gpio5_out | b0 | RW | This bit determines the output signal of the GPIO5 pin when selected as output source. |
| 3 | gpio4_out | b0 | RW | This bit determines the output signal of the GPIO4 pin when selected as output source. |
| 2 | gpio3_out | b0 | RW | This bit determines the output signal of the GPIO3 pin when selected as output source. |
| 1 | gpio2_out | b0 | RW | This bit determines the output signal of the GPIO2 pin when selected as output source. |
| 0 | gpio1_out | b0 | RW | This bit determines the output signal of the GPIO1 pin when selected as output source. |

Figure 76:
GPIOsignal_in

| Addr:21h | | GPIOsignal_in | | |
|----------|----------|---------------|--------|--|
| Bit | Bit Name | Default | Access | Bit Description |
| 4 | gpio5_in | b0 | RO | This bit reflects the logic level of the GPIO5 pin when configured as digital input pin. |
| 3 | gpio4_in | b0 | RO | This bit reflects the logic level of the GPIO4 pin when configured as digital input pin. |
| 2 | gpio3_in | b0 | RO | This bit reflects the logic level of the GPIO3 pin when configured as digital input pin. |
| 1 | gpio2_in | b0 | RO | This bit reflects the logic level of the GPIO2 pin when configured as digital input pin. |
| 0 | gpio1_in | b0 | RO | This bit reflects the logic level of the GPIO1 pin when configured as digital input pin. |

Figure 77:
Reg1_Voltage

| Addr:22h | | Reg1_Voltage | | |
|----------|--------------|--------------|--------|---|
| Bit | Bit Name | Default | Access | Bit Description |
| 6:0 | Reg1_voltage | b0000000 | RW | This register is mapped to the register address 0h+Reg1_select , if gioX_iosf=5 or 6 (Vselect input), and input = 1. This feature allows voltage switching of a predefined regulator with just one GPIO input 0 ..7Fh: Selects voltage and ilimit of LDO or DCDC |

Figure 78:
Reg2_Voltage

| Addr:23h | | Reg2_Voltage | | |
|----------|--------------|--------------|--------|---|
| Bit | Bit Name | Default | Access | Bit Description |
| 6:0 | Reg2_voltage | b0000000 | RW | This register is mapped to the register address 0h+Reg1_select , if gioX_iosf=5 or 6 (Vselect input), and input = 1. This feature allows voltage switching of a predefined regulator with just one GPIO input 0 ..7Fh: Selects voltage and ilimit of LDO or DCDC |

Figure 79:
Reg_Control

| Addr:24h | | Reg_Control | | |
|----------|-------------|-------------|--------|--|
| Bit | Bit Name | Default | Access | Bit Description |
| 5:4 | Reg2_select | b0000 | RW | Select regulator for mapping of Reg2_voltage; 0 : NA 1 : Select 01h SD1Voltage 2 : Select 02h LDO1Voltage 3 : Select 03h LDO2Voltage |
| 1:0 | Reg1_select | b0000 | RW | Select regulator for mapping of Reg1_voltage; 0 : NA 1 : Select 01h SD1Voltage 2 : Select 02h LDO1Voltage 3 : Select 03h LDO2Voltage |

Figure 80:
GPIO_ctrl1

| Addr:25h | | GPIO_ctrl1 | | |
|----------|----------------|------------|--------|--|
| Bit | Bit Name | Default | Access | Bit Description |
| 6:4 | gpio_ctrl_Idx2 | b000 | RW | 0 : No GPIO control 1 : Controlled by GPIO1 2 : Controlled by GPIO2 3 : Controlled by GPIO3 4 : Controlled by GPIO4 5 : Controlled by GPIO5 6 : NA 7 : NA |
| 2:0 | gpio_ctrl_Idx1 | b000 | RW | 0 : No GPIO control 1 : Controlled by GPIO1 2 : Controlled by GPIO2 3 : Controlled by GPIO3 4 : Controlled by GPIO4 5 : Controlled by GPIO5 6 : NA 7 : NA |

Figure 81:
GPIO_ctrl2

| Addr:26h | | GPIO_ctrl2 | | |
|----------|---------------|------------|--------|--|
| Bit | Bit Name | Default | Access | Bit Description |
| 2:0 | gpio_ctrl_sd1 | b000 | RW | 0 : No GPIO control 1 : Controlled by GPIO1 2 : Controlled by GPIO2 3 : Controlled by GPIO3 4 : Controlled by GPIO4 5 : Controlled by GPIO5 6 : NA 7 : NA |

Figure 82:
SD_control1

| Addr:30h | | SD_control1 | | |
|----------|---------------|-------------|--------|--|
| Bit | Bit Name | Default | Access | Bit Description |
| 7 | sd1_enable | b1 | RW | Global stepdown SD1 enable 0 : SD1 disabled 1 : SD1 enabled |
| 6 | sd1_low_noise | b0 | RW | Enables low noise mode of SD1. If enabled smaller current pulses and output ripple is activated 0 : Normal mode. Minimum current pulses of >100mA applied in skip mode 1 : Low noise mode. Only minimum on time applied in skip mode |
| 5 | sd1_fast | b0 | RW_SM | Selects a faster regulation mode for SD1 suitable for larger load changes. 0 : Normal mode, Cext=10µF 1 : Fast mode, Cext=22µF required |
| 4 | sd1_fsel | b0 | RW_SM | Selects between high and low frequency range 0 : 1 MHz if sd1_frequ=0, 3MHz if sd1_frequ=1 1 : 2 MHz if sd1_frequ=0, 4MHz if sd1_frequ=1 |
| 1 | dvm_enable | b0 | RW | Enabling of Dynamic Voltage Management If voltage of SD1 is changed during operation (sd1_vsel) voltage is de/increased by single steps 0 : DVM disabled 1 : DVM enabled |
| 0 | dvm_time | b0 | RW | Time steps of DVM voltage change of SD1 0 : 8 µsec time delay between steps 1 : 16 µsec time delay between steps |

Figure 83:
Battery_voltage_monitor

| Addr:32h | | Battery_voltage_monitor | | |
|----------|-------------|-------------------------|--------|--|
| Bit | Bit Name | Default | Access | Bit Description |
| 7 | FastResEn | b0 | RW | 0 : Vresetfall debounce time = 3msec 1 : Vresetfall debounce time = 64μsec |
| 6 | SupResEn | b0 | RW_SM | 0 : A reset is generated if VSUP falls below 2.7V ⁽¹⁾ 1 : A reset is generated if VSUP falls below ResVoltFall |
| 5:3 | ResVoltFall | b000 | RW_SM | This value determines the reset level ResVoltFall for falling VBAT. It is recommended to set this value at least 200mV lower than ResVoltRise 0 : 2.7V 1 : 2.9V 2 : 3.1V 3 : 3.2V 4 : 3.3V 5 : 3.4V 6 : 3.5V 7 : 3.6V |
| 2:0 | ResVoltRise | b001 | RO | This value determines the reset level ResVoltRise for rising VBAT. It is recommended to set this value at least 200mV higher than ResVoltFall 0 : 2.7V 1 : 2.9V 2 : 3.1V 3 : 3.2V 4 : 3.3V 5 : 3.4V 6 : 3.5V 7 : 3.6V |

Note(s):

1. If VBAT falls below ResVoltFall only an interrupt is generated (if enabled) and the uProcessor can shut down the system.

Figure 84:
Startup_Control

| Addr:33h | | Startup_Control | | |
|----------|----------------------|-----------------|--------|--|
| Bit | Bit Name | Default | Access | Bit Description |
| 7 | chg_pwr_off_en | b0 | RO | Select charger detection in power OFF mode Read only (OTP setting) 0 : Exit of Power OFF mode, if charger is detected (level detection) 1 : Exit of Power OFF mode, if charger insertion is detected (rising edge detection) |
| 6 | power_off_at_vsuplow | b0 | RW_SM | Switch into Power OFF mode if low VSUP is detected during active or standby mode (Pin ON = low and bit <i>auto_off</i> = 0) 0 : If low VSUP(<i>ResVoltFall</i>) is detected, enter VSUP Debounce state, continuously monitor VSUP voltage and startup if VSUP voltage is above <i>ResVoltRise</i> 1 : If low VSUP(<i>ResVoltFall</i>) is detected, enter power OFF mode |
| 5 | stby_reset_disable | b0 | RW | Disable Reset output signal (PIN XRES) in standby mode 0 : Normal mode, reset is active in standby mode 1 : No reset in standby mode and during exit of standby mode |
| 4 | auto_off | b0 | RO | Defines startup behavior at first battery insertion 0 : Startup of chip if VBAT> <i>ResVoltRise</i> 1 : Enter power OFF mode (Startup with ON key or charger insertion) |
| 3:2 | off_delay | b01 | RW | Set Delay between I ² C command, GPIO or Reset signal for power_off, standby mode or reset and execution of that command 0 : No delay 1 : 8 ms (default) 2 : 16 ms 3 : 32 ms |
| 1:0 | res_timer | b00 | RW_SM | Set RESTime, after the last regulator has started 0 : RESTIME=10ms (default) 1 : RESTIME=50ms 2 : RESTIME=100ms 3 : RESTIME=150ms |

Figure 85:
ReferenceControl

| Addr:35h | | ReferenceControl | | |
|----------|--------------------|------------------|--------|---|
| Bit | Bit Name | Default | Access | Bit Description |
| 7 | on_lpress_delay | b0 | RW_SM | Sets the ON reset delay time 0 : 8s (if onkey_lpress_en=1) 1 : 4s (if onkey_lpress_en=1) |
| 6 | on_tast_sw | b0 | RO | Selects mode of ON input 0 : ON key works as push-button 1 : ON key works as switch |
| 5 | onkey_lpress_reset | b0 | RW_SM | Selects behavior for ONKEY longpress 0 : Long onkey press forces change to power_off mode (if on_tast_sw=0 and onkey_lpress_en=1) 1 : Long onkey press forces a reset (if on_tast_sw=0 and onkey_lpress_en=1) |
| 4 | standby_mode_on | b0 | RW_SM | Setting to 1 sets the PMU into standby mode. All regulators are disabled except those regulators enabled by Reg_standby_mod. XRES will be pulled to low. A normal startup of all regulators will be done with any interrupt (has to be enabled before entering standby mode). |
| 3:2 | clk_int | b00 | R_PUSH | Sets the internal CLK frequency fCLK used for DCDCs, PWM, ... 0 : 4 MHz (default) 1 : 3.8 MHz 2 : 3.6 MHz 3 : 3.4 MHz All frequencies, timings and delays in this datasheet are based on 4MHz clk_int |
| 1:0 | pwm_div | b00 | RW | This bit defines the divider ratio of the prescaler for the PWM generator 0 : Divide by 1 1 : Divide by 2 2 : Divide by 4 3 : Divide by 16 |

Figure 86:
ResetControl

| Addr:36h | | ResetControl | | |
|----------|-----------------|--------------|--------|---|
| Bit | Bit Name | Default | Access | Bit Description |
| 7:4 | reset_reason | b0000 | RW_SM | Flags to indicate to the software the reason for the last reset 0 : VPOR has been reached (battery or charger insertion from scratch) 1 : ResVoltFall was reached (battery voltage drop below 2.75V) 2 : Software forced by force_reset 3 : Software forced by power_off and ON was pulled high 4 : Software forced by power_off and charger was detected 5 : External triggered through the pin XRES 6 : Reset caused by overtemperature T140 7 : NA 8 : Reset caused by 4/8 seconds ON key press 9 : NA 10 : NA 11 : Reset caused by interrupt in standby mode 12 : Reset caused by ON pulled high in standby mode |
| 3 | onkey_lpress_en | b0 | RW_SM | 0 : ONKEY longpress feature disabled 1 : ONKEY longpress feature enabled |
| 2 | on_input | b0 | R_PUSH | Read: This flag represents the state of the ON pad directly Write: Setting to 1 resets the 4/8s. Onkey longpress timer |
| 1 | power_off | b0 | RW_SM | Setting to 1 starts a reset cycle, but waits after the Reg_off state for a falling edge on the pin ON or until the charger is detected |
| 0 | force_reset | b0 | RW | Setting to 1 starts a complete reset cycle |

Figure 87:
OvertemperatureControl

| Addr:37h | | OvertemperatureControl | | |
|----------|-----------------|------------------------|--------|---|
| Bit | Bit Name | Default | Access | Bit Description |
| 7 | tco_140_a | b0 | RO | Only used for production test |
| 6 | tco_110_a | b0 | RO | Only used for production test |
| 5:4 | temp_test | b00 | RW | |
| 3 | rst_ov_temp_140 | b0 | RW | If the overtemperature threshold 2 has been reached, the flag ov_temp_140 is set and a reset cycle is started. ov_temp_140 should be reset by writing 1 and afterwards 0 to rst_ov_temp_140 |
| 2 | ov_temp_140 | b0 | RO | Flag that the overtemperature threshold 2 (T140) has been reached - this flag is not reset by a overtemperature caused reset and has to be reset by rst_ov_temp_140 |
| 1 | ov_temp_110 | b0 | RO | Flag that the overtemperature threshold 1 (T110) has been reached |
| 0 | temp_pmc_on | b1 | RW | Switch ON/OFF of temperature supervision; default: ON - all other bits are only valid if set to 1 Leave at 1, do not disable |

Figure 88:
Reg_standby_mod1

| Addr:39h | | Reg_standby_mod1 | | |
|----------|---------------|------------------|--------|---|
| Bit | Bit Name | Default | Access | Bit Description |
| 3 | disable_regpd | b0 | RW | This bit disables the pulldown of all regulators 0 : Normal operation approx. 1kohm pulldown of all regulators 1 : Pulldown disabled >100kohm of all regulators |
| 2 | sd1_stby_on | b0 | RW | Enable Step down 1 in standby mode |
| 1 | ldo2_stby_on | b0 | RW | Enable LDO2 in standby mode |
| 0 | ldo1_stby_on | b0 | RW | Enable LDO1 in standby mode |

Figure 89:
pwm_control_l

| Addr:41h | | pwm_control_l | | |
|----------|------------|---------------|--------|---|
| Bit | Bit Name | Default | Access | Bit Description |
| 7:0 | pwm_l_time | b00000000 | RW | This bit defines the low time of the pwm generator in 1MHz units 0 : pwm_div * 1μs 1 : pwm_div * 2μs 2 : pwm_div * 3μs ... : ... 255 : pwm_div * 256μs |

Figure 90:
pwm_control_h

| Addr:42h | | pwm_control_h | | |
|----------|------------|---------------|--------|--|
| Bit | Bit Name | Default | Access | Bit Description |
| 7:0 | pwm_h_time | b00000000 | RW | This bit defines the high time of the pwm generator in 1MHz units 0 : pwm_div * 1μs 1 : pwm_div * 2μs 2 : pwm_div * 3μs ... : ... 255 : pwm_div * 256μs |

Figure 91:
curr1_value

| Addr:43h | | curr1_value | | |
|----------|---------------|-------------|--------|---|
| Bit | Bit Name | Default | Access | Bit Description |
| 7:0 | curr1_current | b00000000 | RW | Defines the current into CURR1 if <i>gpio1_mode</i> = 7 0 : Power down (default state) 1 : 0.15686mA (LSB) ... : ... 255 : 40mA |

Figure 92:
curr2_value

| Addr:44h | | curr2_value | | |
|----------|---------------|-------------|--------|---|
| Bit | Bit Name | Default | Access | Bit Description |
| 7:0 | curr2_current | b00000000 | RW | Defines the current into CURR2 if <i>gpio2_mode</i> = 7 0 : Power down (default state) 1 : 0.15686mA (LSB) ... : ... 255 : 40mA |

Figure 93:
RegStatus

| Addr:73h | | RegStatus | | |
|----------|----------|-----------|--------|---|
| Bit | Bit Name | Default | Access | Bit Description |
| 6 | curr2_lv | b0 | RO | Bit is set when voltage of current sink CURR2 drops below low voltage threshold (1ms debounce time default) |
| 5 | curr1_lv | b0 | RO | Bit is set when voltage of current sink CURR1 drops below low voltage threshold (1ms debounce time default) |
| 0 | sd1_lv | b0 | RO | Bit is set when voltage of step down1 drops below low voltage threshold (-5%) (1ms debounce time default) |

Figure 94:
InterruptMask1

| Addr:74h | | InterruptMask1 | | |
|----------|---------------|----------------|--------|-------------------------|
| Bit | Bit Name | Default | Access | Bit Description |
| 7 | LowBat_int_m | b1 | RW | Rising edge only |
| 6 | ovtmp_int_m | b1 | RW | Rising edge only |
| 5 | onkey_int_m | b1 | RW | Rising and falling edge |
| 4 | chdet_int_m | b1 | RW | Rising and falling edge |
| 3 | eoc_int_m | b1 | RW | Rising and falling edge |
| 2 | resume_int_m | b1 | RW | Rising and falling edge |
| 1 | nobat_int_m | b1 | RW | Rising and falling edge |
| 0 | trickle_int_m | b1 | RW | Rising and falling edge |

Figure 95:
InterruptMask2

| Addr:75h | | InterruptMask2 | | |
|----------|--------------------|----------------|--------|-------------------------|
| Bit | Bit Name | Default | Access | Bit Description |
| 7 | gpio5_int_m | b1 | RW | Rising and falling edge |
| 6 | gpio4_int_m | b1 | RW | Rising and falling edge |
| 5 | gpio3_int_m | b1 | RW | Rising and falling edge |
| 4 | gpio2_int_m | b1 | RW | Rising and falling edge |
| 3 | gpio1_int_m | b1 | RW | Rising and falling edge |
| 2 | gpio_restart_int_m | b1 | RW | Falling edge only |
| 1 | sd1_lv_int_m | b1 | RW | Rising edge only |
| 0 | bat_temp_m | b1 | RW | Rising and falling edge |

Figure 96:
InterruptStatus1

| Addr:77h | | InterruptStatus1 | | |
|----------|---------------|------------------|--------|--|
| Bit | Bit Name | Default | Access | Bit Description |
| 7 | LowBat_int_i | b0 | RO | Bit is set when VSUP drops below ResVoltFall |
| 6 | ovtmp_int_i | b0 | RO | Bit is set when 110deg is exceeded |
| 5 | onkey_int_i | b0 | RO | |
| 4 | chdet_int_i | b0 | RO | |
| 3 | eoc_int_i | b0 | RO | |
| 2 | resume_int_i | b0 | RO | |
| 1 | nobat_int_i | b0 | RO | |
| 0 | trickle_int_i | b0 | RO | |

Figure 97:
InterruptStatus2

| Addr:78h | | InterruptStatus2 | | |
|----------|--------------------|------------------|--------|-----------------|
| Bit | Bit Name | Default | Access | Bit Description |
| 7 | gpio5_int_i | b0 | RO | |
| 6 | gpio4_int_i | b0 | RO | |
| 5 | gpio3_int_i | b0 | RO | |
| 4 | gpio2_int_i | b0 | RO | |
| 3 | gpio1_int_i | b0 | RO | |
| 2 | gpio_restart_int_i | b0 | RO | |
| 1 | sd1_lv_int_i | b0 | RO | |
| 0 | bat_temp_i | b0 | RO | |

Figure 98:
ChargerControl

| Addr:80h | | ChargerControl | | |
|----------|---------------------|----------------|--------|---|
| Bit | Bit Name | Default | Access | Bit Description |
| 7 | cc_range_select | b0 | RW | Defines the charging current range for constant current mode 0 : High current range 1 : Low current range |
| 6 | AutoResume | b0 | RW | 0 : Charging does not restart automatically in EOC when bit Resume is set. 1 : Charging will restart automatically in EOC when bit Resume is set and vbat is below resume level |
| 5 | bat_charging_enable | b0 | RW | 0 : USB is supplying VSUP, battery switch is open, ideal diode operation. USB charger regulates to <i>vsup_voltage</i> 1 : Normal battery charger operation from USB charger, battery switched is closed |
| 4 | usb_chgEn | b1 | RW | 0 : USB input is disconnected, battery switch is closed 1 : USB input is connected and supplying VSUP, battery switch is open, ideal diode operation. USB charger regulates <i>vsup_voltage</i> . |
| 3:0 | usb_Current | b0000 | RW | Sets the USB input current limit. 0 : 94mA (default) 1 : 141mA 2 : 189mA 3 : 237mA 4 : 285mA 5 : 332mA 6 : 380mA 7 : 428mA 8 : 470mA 9 : 517mA 10 : 600mA 11 : 764mA 12 : 889mA 13 : 1065mA 14 : NA 15 : NA |

Figure 99:
ChargerVoltageControl

| Addr:81h | | ChargerVoltageControl | | |
|----------|-----------|-----------------------|--------|--|
| Bit | Bit Name | Default | Access | Bit Description |
| 7:6 | Vsup_min | b01 | RW | Regulate down battery charging current on that level of Vsup during trickle charging and constant current charging, to prevent voltage drop on vsup: 0 : 3.90V 1 : 4.20V (default) 2 : 4.50V 3 : 4.70V |
| 4:0 | ChVoltEOC | b10011 | RW | Sets the end-of-charge voltage level VCHOFF. 0 : 3.82V 1 : 3.84V ... 19 : 4.20V (default) ... 31 : 4.44V |

Figure 100:
ChargerCurrentControl

| Addr:82h | | ChargerCurrentControl | | |
|----------|------------------|-----------------------|--------|---|
| Bit | Bit Name | Default | Access | Bit Description |
| 7:4 | TrickleCurrent | b0000 | RW | Sets the charging current limit in trickle current mode. 0 : 11mA (default) 1 : 23mA 2 : 35mA 3 : 47mA 4 : 59mA 5 : 70mA 6 : 82mA 7 : 94mA 8 : 106mA 9 : 118mA 10 : 130mA 11 : NA 12 : NA 13 : NA 14 : NA 15 : NA |
| 3:0 | Constant Current | b0000 | RW | Sets the charging current limit in constant current mode. 0 : 44mA if cc_range_select=0, 11mA if cc_range_select=1 (default) 1 : 88mA if cc_range_select=0, 23mA if cc_range_select=1 2 : 133mA if cc_range_select=0, 35mA if cc_range_select=1 3 : 178mA if cc_range_select=0, 47mA if cc_range_select=1 4 : 223mA if cc_range_select=0, 59mA if cc_range_select=1 5 : 268mA if cc_range_select=0, 70mA if cc_range_select=1 6 : 313mA if cc_range_select=0, 82mA if cc_range_select=1 7 : 358mA if cc_range_select=0, 94mA if cc_range_select=1 8 : 403mA if cc_range_select=0, 106mA if cc_range_select=1 9 : 448mA if cc_range_select=0, 118mA if cc_range_select=1 10 : 494mA if cc_range_select=0, 130mA if cc_range_select=1 11 : NA 12 : NA 13 : NA 14 : NA 15 : NA |

Figure 101:
ChargerConfig1

| Addr:83h | | ChargerConfig1 | | |
|----------|------------------|----------------|--------|--|
| Bit | Bit Name | Default | Access | Bit Description |
| 7 | Charging_1Hz_clk | b0 | RW | Sets the mode for the charging output status (<i>gpioX_iosf</i> = 10) 0 : Normal operation: charging=1, not charging=0 1 : 1Hz blinking operation: charging=1Hz, not charging=0 |
| 6 | ChVolt Resume | b0 | RW | Sets the resume voltage level VCHRES 0 : 3.33% of ChVoltEOC (140mV default) 1 : 5.56% of ChVoltEOC (233mV default) |
| 5:4 | temp_sel | b00 | RW | Selects temperature regulation of charging current (die temp.) 0 : 120degC 1 : 130degC 2 : 110degC 3 : 90degC |
| 3:1 | vsup_voltage | b100 | RW | Voltage regulation of VSUP of the input current limiter 0 : 4.4V 1 : 4.5V 2 : 4.6V 3 : 4.7V 4 : 4.8V (default) 5 : 4.9V 6 : 5.0V 7 : 5.5V |

Figure 102:
ChargerConfig2

| Addr:84h | | ChargerConfig2 | | |
|----------|---------------|----------------|--------|---|
| Bit | Bit Name | Default | Access | Bit Description |
| 7:5 | eoc_current | b001 | RW | Sets eoc current 0 : 5% of ConstantCurrent 1 : 10% of ConstantCurrent (default) 2 : 15% of ConstantCurrent 3 : 20% of ConstantCurrent 4 : 25% of ConstantCurrent 5 : 30% of ConstantCurrent 6 : 40% of ConstantCurrent 7 : 50% of ConstantCurrent |
| 4 | charging_tmax | b0 | R_PUSH | Write: reset charger timeout counter 0 : Read: No timeout reached 1 : Charging timeout reached and charging stopped |
| 3:0 | ch_timeout | b0111 | RW | Charging timeout timer 0 : OFF 1 : 0.5h 2 : 1h 3 : 1.5h 4 : 2h 5 : 2.5h 6 : 3h 7 : 3.5h(default) 8 : 4h 9 : 4.5h 10 : 5h 11 : 5.5h 12 : 6h 13 : 6.5h 14 : 7h 15 : 7.5h |

Figure 103:
ChargerSupervision

| Addr:85h | | ChargerSupervision | | |
|----------|-------------|--------------------|--------|---|
| Bit | Bit Name | Default | Access | Bit Description |
| 7 | ntc_high_on | b1 | RW | Enables the battery high temperature supervision via NTC resistor (depends on ntc_mode) 0 : NTC battery 45/60deg temp supervision disabled 1 : NTC battery 45/60deg temp supervision enabled |
| 6 | ntc_low_on | b0 | RW | Enables the battery low temperature supervision via NTC resistor 0 : NTC battery 0deg temp supervision disabled 1 : NTC battery 0deg temp supervision enabled |
| 5 | ntc_10k | b0 | RW | Select NTC resistor 0 : 100k (ntc_current = 15 μ A) 1 : 10k (ntc_current = 150 μ A) |
| 4 | ntc_mode | b0 | RW | Defines the temperature level for the battery high temperature supervision 0 : 45deg 1 : 60deg |
| 3:2 | NTC_input | b00 | RW | Defines the NTC input 0 : no NTC input 1 : XIRQ_NTC pin 2 : GPIO3 pin 3 : GPIO4 pin |
| 1:0 | ntc_beta | b00 | RW | Sets the ntc beta 0 : 3000 (0deg:1.41V & 45deg:0.59V/60deg:0.42V) 1 : 3500 (0deg:1.49V & 45deg:0.54V/60deg:0.37V) 2 : 4000 (0deg:1.56V & 45deg:0.50V/60deg:0.31V) 3 : 4500 (0deg:1.63V & 45deg:0.46V/60deg:0.27V) |

Figure 104:
ChargerStatus1

| Addr:86h | | ChargerStatus1 | | |
|----------|-----------|----------------|--------|---|
| Bit | Bit Name | Default | Access | Bit Description |
| 7 | NoBat | b0 | R | Bit is set when battery detection circuit indicates that no battery is connected to the system. |
| 6:5 | temp_cond | b00 | R | Indicates temperature condition 0 : Battery is in typical condition (0deg < battemp < 45/60deg) 1 : Battery is in cold condition (battemp < 0deg) 2 : Battery is in hot condition (battemp > 45/60deg) 3 : NA |
| 4 | EOC | b0 | R | Bit is set if End of charge state has been reached |
| 3 | CVM | b0 | R | Bit is set if charger is operating in constant voltage mode |
| 2 | Trickle | b0 | R | Bit is set, if charger is operating in trickle current. Vbat<2.9V |
| 1 | Resume | b0 | R | Bit is set if Battery voltage is below resume level |
| 0 | CCM | b0 | R | Bit is set if charger is operating in constant current mode |

Figure 105:
ChargerStatus2

| Addr:87h | | ChargerStatus2 | | |
|----------|------------|----------------|--------|--|
| Bit | Bit Name | Default | Access | Bit Description |
| 3 | chdet_off | b0 | RW | SW can turn OFF charger detection circuit for power-OFF state 0 : Charger detection is always enabled 1 : Charger detection is disabled in power-OFF state |
| 2 | ChDet | b0 | R | Bit is set when external charge adapter has been detected on pin USB |
| 1:0 | batsw_mode | b00 | R | Bit indicates the status of the battery switch operation mode 0 : Battery switch is closed (charger disconnected or (charger connected and <i>usb_chgEn</i> =0)) 1 : Battery switch is open, ideal diode operation (charger connected but EOC reached) 2 : Battery switch is closed and acting as a voltage limited current source (charging) |

Figure 106:
LockRegister

| Addr:8eh | | LockRegister | | |
|----------|--------------|--------------|--------|--|
| Bit | Bit Name | Default | Access | Bit Description |
| 2 | charger_lock | b0 | R | Enables lock of the charger registers 81h, 82h, 83h, 84h Chargervoltagecontrol, Chargercurrentcontrol, Chargerconfig1, Chargerconfig2 Bits can only be set. Reset only with full reset cycle |
| 1:0 | reg_lock | b00 | R | Enables lock of Regulator voltages Bits can only be set. Reset only with full reset cycle Disable write to testmodes registers if LDO_lock>0 writing stepdown voltage to 0 should be possible all the time to allow switching ON the regulator. Writing a nonzero value after that should restore the old value 0 : No lock 1 : Lock of voltage of LDOs (LDOx_vsel) (all bits) and voltage of StepDownBits(sdx_vsel) [5:6] only 2 : Lock voltage of StepDownBits(sdx_vsel) [5:6] only 3 : Lock voltage of StepDown (all bits) and LDOs (all bits). |

Figure 107:
ASIC_ID1

| Addr:90h | | ASIC_ID1 | | |
|----------|----------|-----------|--------|-----------------|
| Bit | Bit Name | Default | Access | Bit Description |
| 7:0 | ID1 | b00010001 | RO | |

Figure 108:
ASIC_ID2

| Addr:91h | | ASIC_ID2 | | |
|----------|----------|----------|--------|-----------------|
| Bit | Bit Name | Default | Access | Bit Description |
| 3:0 | revision | b0000 | RO | |

Figure 109:
Fuse5

| Addr:a5h | | Fuse5 | | |
|----------|----------|---------|--------|-----------------|
| Bit | Bit Name | Default | Access | Bit Description |
| 7 | del_time | b0 | RW | |
| 6 | sequ_on | b0 | RW | |

Figure 110:
Fuse6

| Addr:a6h | | Fuse6 | | |
|----------|--------------------|---------|--------|---|
| Bit | Bit Name | Default | Access | Bit Description |
| 2 | on_tast_sw | b0 | RW | Selects mode of ON input 0 : ON key works as push-button 1 : ON key works as switch |
| 1 | onkey_lpress_reset | b0 | RW | Selects behavior for ONKEY longpress 0 : Long onkey press forces change to power_off mode (if on_tast_sw=0 and onkey_lpress_en=1) 1 : Long onkey press forces a reset (if on_tast_sw=0 and onkey_lpress_en=1) |
| 0 | on_invert | b0 | RW | Inverts the ON input 0 : ON input is active high (default) 1 : ON input is active low |

Figure 111:
Fuse7

| Addr:a7h | | Fuse7 | | |
|----------|----------------------|---------|--------|---|
| Bit | Bit Name | Default | Access | Bit Description |
| 7 | auto_off | b0 | RW | Defines startup behavior at first battery insertion 0 : Startup of chip if VBAT>ResVoltRise 1 : Enter power OFF mode (Startup with ON key or charger insertion) |
| 6 | chg_pwr_off_en | b0 | RW | Enable power OFF mode, if charger is detected 0 : Exit of Power OFF mode, if charger is detected (level) 1 : Exit of Power OFF mode, if charger insertion is detected (rising edge only) |
| 5:4 | res_timer | b00 | RW | Set RESTime, after the last regulator has started 0 : RESTIME=10ms 1 : RESTIME=50ms 2 : RESTIME=100ms 3 : RESTIME=150ms |
| 3 | sd1_fsel | b0 | RW | Selects between high and low frequency range 0 : 1 MHz if sd1_frequ=0, 3MHz if sd1_frequ=1 1 : 2 MHz if sd1_frequ=0, 4MHz if sd1_frequ=1 |
| 2 | sd1_fast | b0 | RW | Selects a faster regulation mode for SD1 suitable for larger load changes. 0 : Normal mode, Cext=10μF 1 : Fast mode, Cext=22μF required |
| 1 | power_off_at_vsuplow | b0 | RW | Switch into Power off mode if low VSUP is detected during active or standby mode (Pin ON = low and bit <i>auto_off</i> = 0) 0 : If low VSUP(<i>ResVoltFall</i>) is detected, enter VSUP Debounce state, continuously monitor VSUP voltage and startup if VSUP voltage is above <i>ResVoltRise</i> 1 : If low VSUP(<i>ResVoltFall</i>) is detected, enter power OFF mode |
| 0 | i2c_deva_bit1 | b0 | RW | |

Figure 112:
Fuse8

| Addr:a8h | | Fuse8 | | |
|----------|-----------------|---------|--------|---|
| Bit | Bit Name | Default | Access | Bit Description |
| 7:4 | usb_current | b0000 | RW | Sets the USB input current limit. 0 : 94mA (default) 1 : 141mA 2 : 189mA 3 : 237mA 4 : 285mA 5 : 332mA 6 : 380mA 7 : 428mA 8 : 470mA 9 : 517mA 10 : 600mA 11 : 764mA 12 : 889mA 13 : 1065mA 14 : NA (1065mA) 15 : NA (1065mA) |
| 3:1 | ResVoltRise | b000 | RW | This value determines the reset level ResVoltRise for rising VBAT. ResVoltFall is set to ResVoltRise-200mV by default 0 : 2.7V 1 : 2.9V 2 : 3.1V 3 : 3.2V 4 : 3.3V 5 : 3.4V 6 : 3.5V 7 : 3.6V |
| 0 | on_lpress_delay | b0 | RW | Selects default state of the bit on_lpress_delay |

Figure 113:
Fuse9

| Addr:a9h | | Fuse9 | | |
|----------|-----------------|---------|--------|---|
| Bit | Bit Name | Default | Access | Bit Description |
| 7 | Reg4_del | b0 | RW | Define delay for timeslot4 (regulator 4) |
| 6 | Reg3_del | b0 | RW | Define delay for timeslot3 (regulator 3) |
| 5 | Reg2_del | b0 | RW | Define delay for timeslot2 (regulator 2) |
| 4 | Reg1_del | b0 | RW | Define delay for timeslot1 (regulator 1) |
| 3 | SupResEn | b0 | RW | Presets that bit |
| 2 | onkey_lpress_en | b0 | RW | Select default state of the onkey_lpress_en |
| 1:0 | NTC_input | b00 | RW | Defines the NTC input 0 : No NTC input 1 : XIRQ_NTC pin 2 : GPIO3 pin 3 : GPIO4 pin |

Figure 114:
Fuse10

| Addr:aah | | Fuse10 | | |
|----------|-----------|---------|--------|--|
| Bit | Bit Name | Default | Access | Bit Description |
| 7:4 | Reg2_addr | b0000 | RW | Define startup regulator 2 0 : NA (00h) 1 : SD1 (01h) 2 : LDO1 (02h) 3 : LDO2 (03h) 4 : NA (04h) 5 : NA (05h) 6 : NA (06h) 7 : NA (07h) 8 : NA (08h) 9 : GPIO1 (09h) 10 : GPIO2 (0ah) 11 : GPIO3 (0bh) 12 : GPIO4 (0ch) 13 : GPIO5 (0dh) 14 : NA (0eh) 15 : NA (0fh) |
| 3:0 | Reg1_addr | b0000 | RW | Define startup regulator 1 0 : NA (00h) 1 : SD1 (01h) 2 : LDO1 (02h) 3 : LDO2 (03h) 4 : NA (04h) 5 : NA (05h) 6 : NA (06h) 7 : NA (07h) 8 : NA (08h) 9 : GPIO1 (09h) 10 : GPIO2 (0ah) 11 : GPIO3 (0bh) 12 : GPIO4 (0ch) 13 : GPIO5 (0dh) 14 : NA (0eh) 15 : NA (0fh) |

Figure 115:
Fuse11

| Addr:abh | | Fuse11 | | |
|----------|----------|-----------|--------|--|
| Bit | Bit Name | Default | Access | Bit Description |
| 7:0 | reg1_V | b00000000 | RW | Define startup voltage for regulator 1 |

Figure 116:
Fuse12

| Addr:ach | | Fuse12 | | |
|----------|----------|-----------|--------|--|
| Bit | Bit Name | Default | Access | Bit Description |
| 7:0 | reg2_V | b00000000 | RW | Define startup voltage for regulator 2 |

Figure 117:
Fuse13

| Addr:adh | | Fuse13 | | |
|----------|-----------|---------|--------|--|
| Bit | Bit Name | Default | Access | Bit Description |
| 7:4 | Reg4_addr | b0000 | RW | Define startup regulator 4 0 : NA (00h) 1 : SD1 (01h) 2 : LDO1 (02h) 3 : LDO2 (03h) 4 : NA (04h) 5 : NA (05h) 6 : NA (06h) 7 : NA (07h) 8 : NA (08h) 9 : GPIO1 (09h) 10 : GPIO2 (0ah) 11 : GPIO3 (0bh) 12 : GPIO4 (0ch) 13 : GPIO5 (0dh) 14 : NA (0eh) 15 : NA (0fh) |
| 3:0 | Reg3_addr | b0000 | RW | Define startup regulator 3 0 : NA (00h) 1 : SD1 (01h) 2 : LDO1 (02h) 3 : LDO2 (03h) 4 : NA (04h) 5 : NA (05h) 6 : NA (06h) 7 : NA (07h) 8 : NA (08h) 9 : GPIO1 (09h) 10 : GPIO2 (0ah) 11 : GPIO3 (0bh) 12 : GPIO4 (0ch) 13 : GPIO5 (0dh) 14 : NA (0eh) 15 : NA (0fh) |

Figure 118:
Fuse14

| Addr: aeh | | Fuse14 | | |
|-----------|----------|-----------|--------|--|
| Bit | Bit Name | Default | Access | Bit Description |
| 7:0 | reg3_V | b00000000 | RW | Define startup voltage for regulator 3 |

Figure 119:
Fuse15

| Addr: afh | | Fuse15 | | |
|-----------|----------|-----------|--------|--|
| Bit | Bit Name | Default | Access | Bit Description |
| 7:0 | reg4_V | b00000000 | RW | Define startup voltage for regulator 4 |

Application Information

Figure 120:
Application Schematic

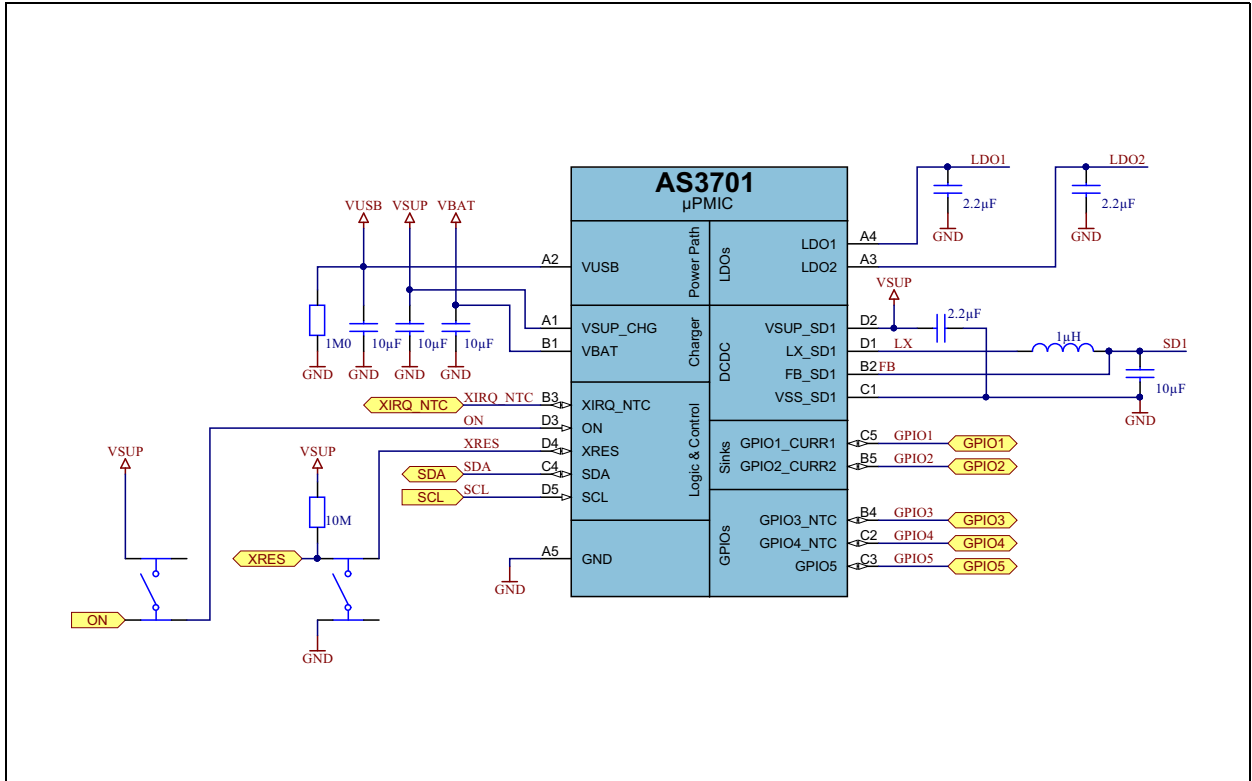

Figure 121:
Layout Guidelines for AS3701A

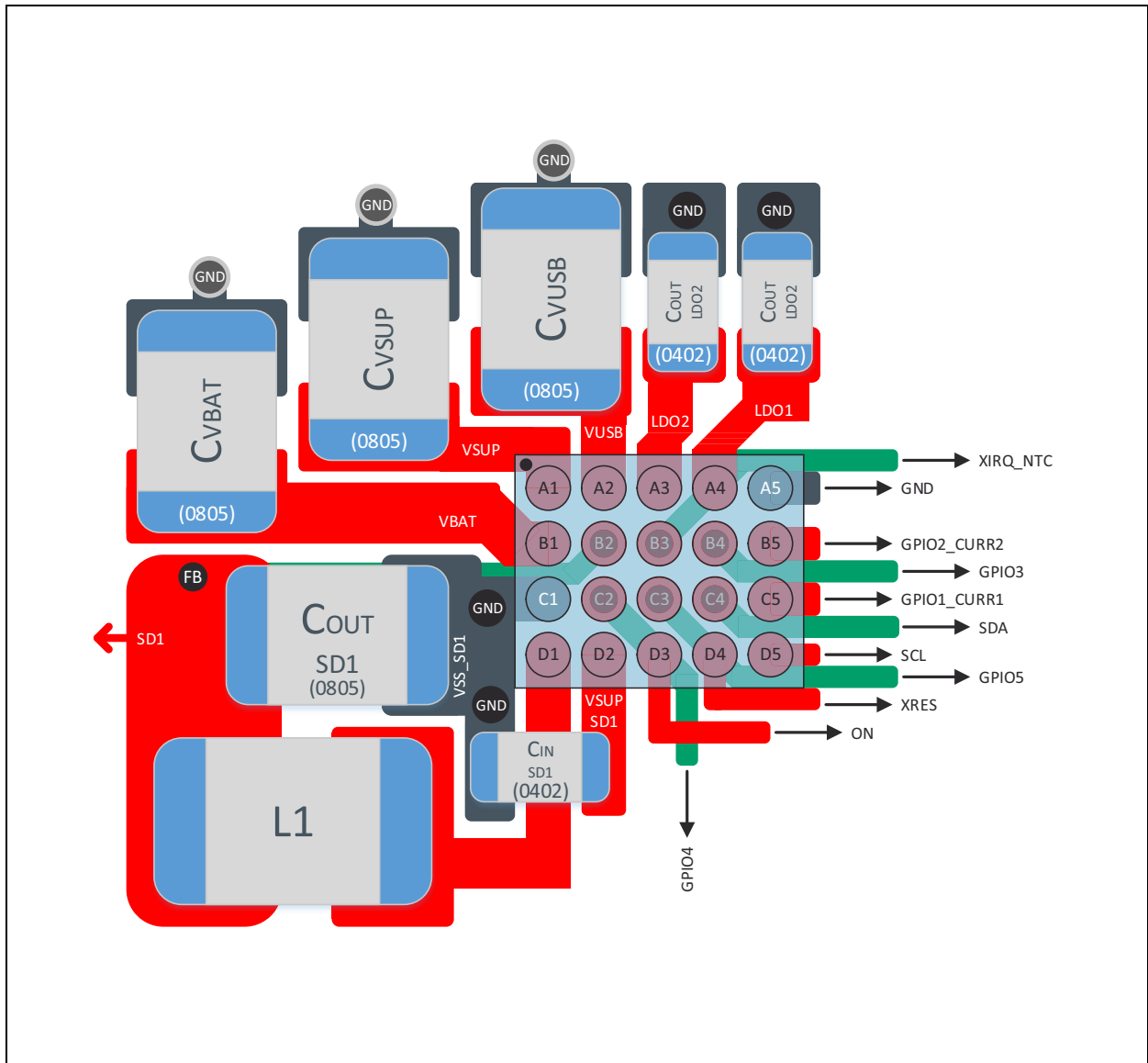

Figure 122:
Layout Guidelines for AS3701B

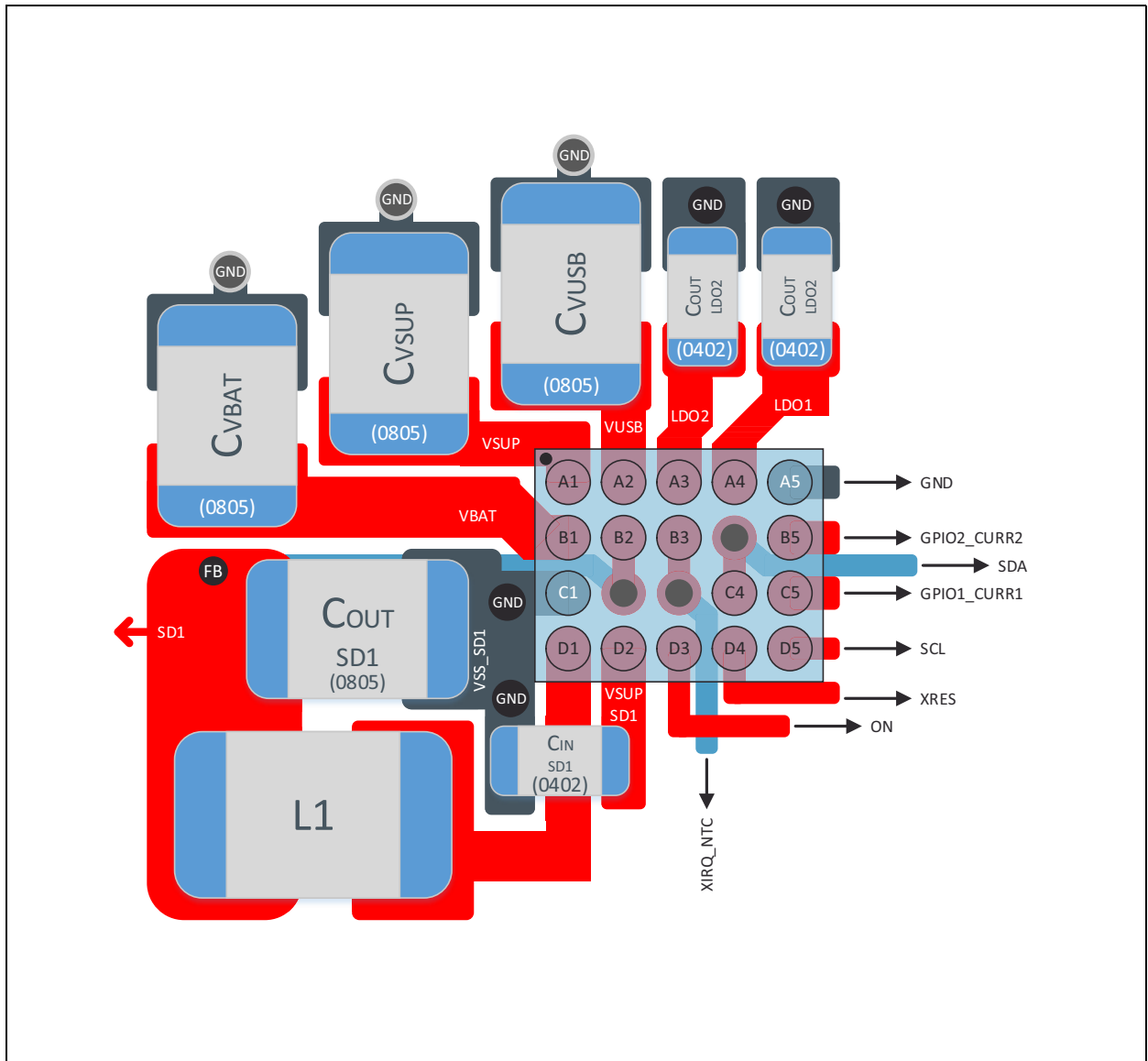
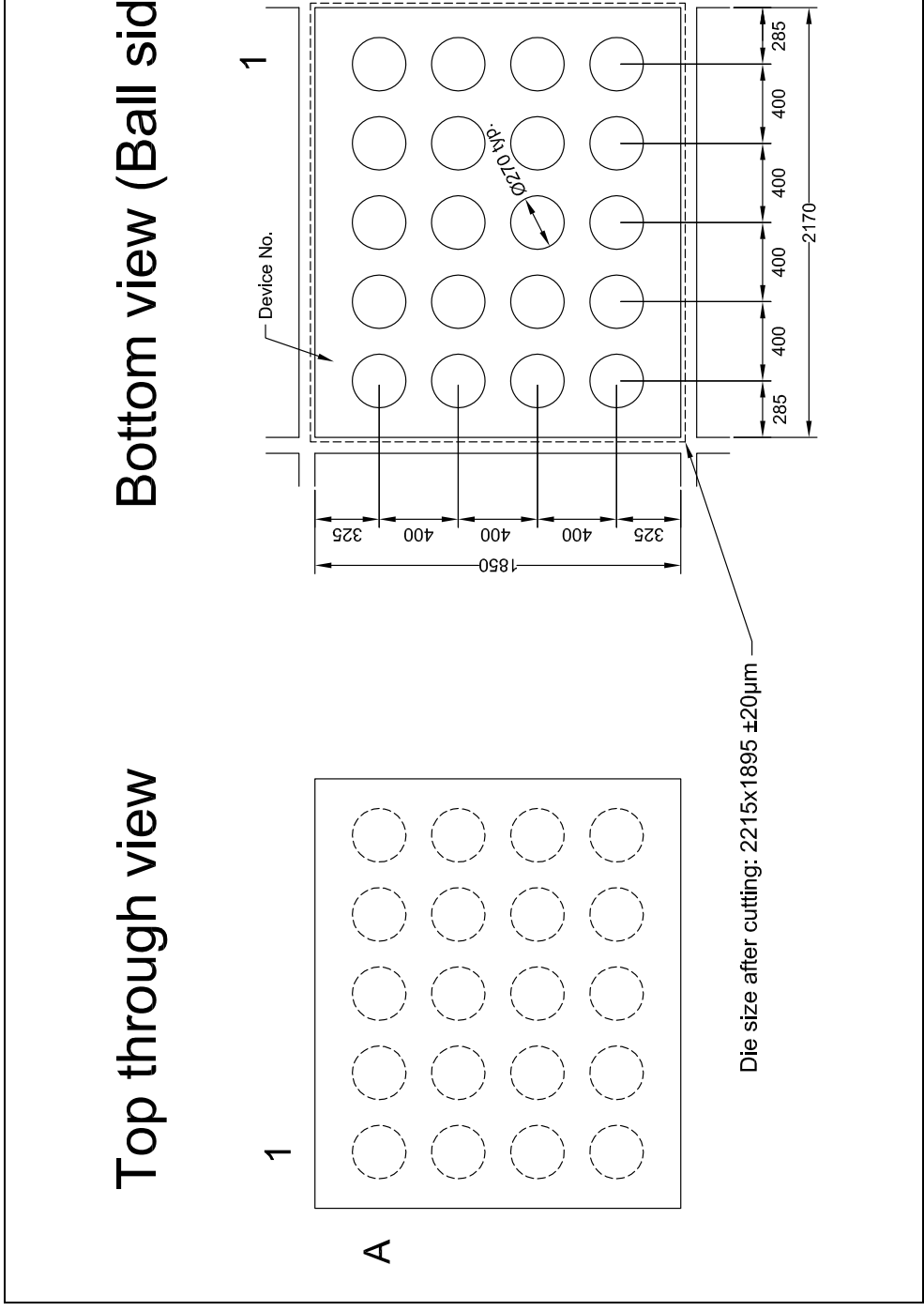

Figure 124:
CSP-20 0.4mm Pitch Package Drawing



Note(s):

1. Pin 1 = A1
2. ccc Coplanarity
3. All dimensions are in µm

ams Datasheet

[V1-11] 2016-Dec-14

Figure 125:
AS3701A Marking

AS3701A Marking: Shows the package marking of the AS3701A product version

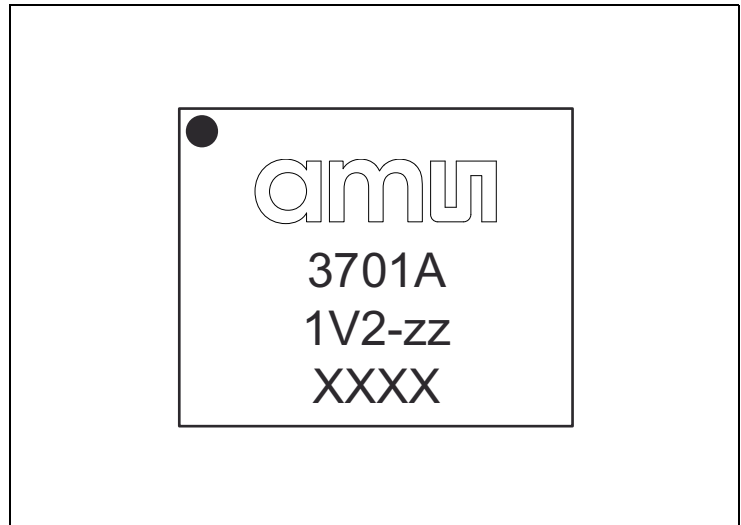

Figure 126:
AS3701B Marking

AS3701B Marking: Shows the package marking of the AS3701B product version

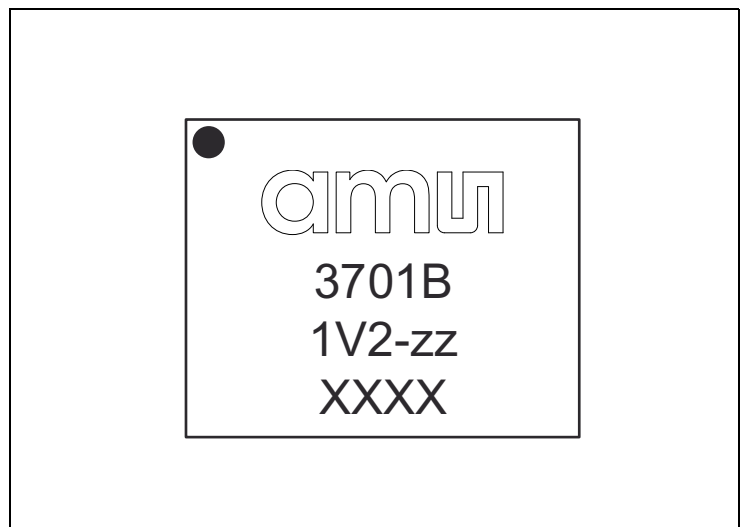

Figure 127:
Package Code

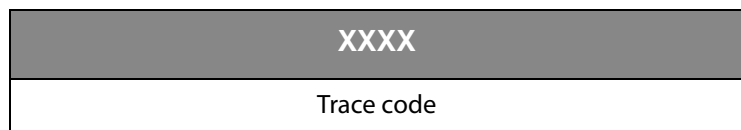

Figure 128:
Start-Up Revision Code

| 1V1-?? | Sequence |
|--------|--|
| 1V1-ES | Engineering samples, no sequence programmed or sequence programmed on request |
| 1V1-00 | Standard programming (no sequence programmed) |
| 1V1-?? | Other customer specified sequence programmed during production test ⁽¹⁾ |

Start-Up Revision Code: Shows the coding of the different startup sequences

Note(s):

1. Dedicated OTP startup sequence settings available upon request. Please contact www.ams.com/Technical-Support.

Ordering & Contact Information

Figure 129:
Ordering Information

| Ordering Code | Package | Marking | OTP Programming | Delivery Form | Delivery Quantity |
|-----------------|----------------|-----------------|----------------------------------|----------------------|-------------------|
| AS3701A-BWLW-ES | 17-Ball WL-CSP | 3701A 1V2-ES | Sequence programmable on request | Waffle Pack | Max. 50 pcs |
| AS3701A-BWLM-?? | 17-Ball WL-CSP | 3701A 1V2-?? | Customer specified sequence | T & R (mini reel) | 500 pcs/reel |
| AS3701A-BWLT-?? | 17-Ball WL-CSP | 3701A 1V2-?? | Customer specified sequence | T & R | 12000 pcs/reel |
| AS3701B-BWLW-ES | 20-Ball WL-CSP | 3701B 1V2-ES | Sequence programmable on request | Waffle Pack | Max. 50 pcs |
| AS3701B-BWLM-00 | 20-Ball WL-CSP | 3701B 1V2-00 | Default sequence | T & R (mini reel) | 500 pcs/reel |
| AS3701B-BWLT-00 | 20-Ball WL-CSP | 3701B 1V2-00 | Default sequence | T & R | 12000 pcs/reel |
| AS3701B-BWLM-?? | 20-Ball WL-CSP | 3701B 1V2-?? | Customer specified sequence | T & R (mini reel) | 500 pcs/reel |
| AS3701B-BWLT-?? | 20-Ball WL-CSP | 3701B 1V2-?? | Customer specified sequence | T & R | 12000 pcs/reel |

Buy our products or get free samples online at:
www.ams.com/ICdirect

Technical Support is available at:
www.ams.com/Technical-Support

Provide feedback about this document at:
www.ams.com/Document-Feedback

For further information and requests, e-mail us at:
ams_sales@ams.com

For sales offices, distributors and representatives, please visit:
www.ams.com/contact

Headquarters

ams AG
Tobelbader Strasse 30
8141 Premstaetten
Austria, Europe

Tel: +43 (0) 3136 500 0

Website: www.ams.com

RoHS Compliant & ams Green Statement

RoHS: The term RoHS compliant means that ams AG products fully comply with current RoHS directives. Our semiconductor products do not contain any chemicals for all 6 substance categories, including the requirement that lead not exceed 0.1% by weight in homogeneous materials. Where designed to be soldered at high temperatures, RoHS compliant products are suitable for use in specified lead-free processes.

ams Green (RoHS compliant and no Sb/Br): ams Green defines that in addition to RoHS compliance, our products are free of Bromine (Br) and Antimony (Sb) based flame retardants (Br or Sb do not exceed 0.1% by weight in homogeneous material).

Important Information: The information provided in this statement represents ams AG knowledge and belief as of the date that it is provided. ams AG bases its knowledge and belief on information provided by third parties, and makes no representation or warranty as to the accuracy of such information. Efforts are underway to better integrate information from third parties. ams AG has taken and continues to take reasonable steps to provide representative and accurate information but may not have conducted destructive testing or chemical analysis on incoming materials and chemicals. ams AG and ams AG suppliers consider certain information to be proprietary, and thus CAS numbers and other limited information may not be available for release.

Copyrights & Disclaimer

Copyright ams AG, Tobelbader Strasse 30, 8141 Premstaetten, Austria-Europe. Trademarks Registered. All rights reserved. The material herein may not be reproduced, adapted, merged, translated, stored, or used without the prior written consent of the copyright owner.

Devices sold by ams AG are covered by the warranty and patent indemnification provisions appearing in its General Terms of Trade. ams AG makes no warranty, express, statutory, implied, or by description regarding the information set forth herein. ams AG reserves the right to change specifications and prices at any time and without notice. Therefore, prior to designing this product into a system, it is necessary to check with ams AG for current information. This product is intended for use in commercial applications. Applications requiring extended temperature range, unusual environmental requirements, or high reliability applications, such as military, medical life-support or life-sustaining equipment are specifically not recommended without additional processing by ams AG for each application. This product is provided by ams AG "AS IS" and any express or implied warranties, including, but not limited to the implied warranties of merchantability and fitness for a particular purpose are disclaimed.

ams AG shall not be liable to recipient or any third party for any damages, including but not limited to personal injury, property damage, loss of profits, loss of use, interruption of business or indirect, special, incidental or consequential damages, of any kind, in connection with or arising out of the furnishing, performance or use of the technical data herein. No obligation or liability to recipient or any third party shall arise or flow out of ams AG rendering of technical or other services.

Document Status

| Document Status | Product Status | Definition |
|--------------------------|-----------------|--|
| Product Preview | Pre-Development | Information in this datasheet is based on product ideas in the planning phase of development. All specifications are design goals without any warranty and are subject to change without notice |
| Preliminary Datasheet | Pre-Production | Information in this datasheet is based on products in the design, validation or qualification phase of development. The performance and parameters shown in this document are preliminary without any warranty and are subject to change without notice |
| Datasheet | Production | Information in this datasheet is based on products in ramp-up to full production or full production which conform to specifications in accordance with the terms of ams AG standard warranty as given in the General Terms of Trade |
| Datasheet (discontinued) | Discontinued | Information in this datasheet is based on products which conform to specifications in accordance with the terms of ams AG standard warranty as given in the General Terms of Trade, but these products have been superseded and should not be used for new designs |

Revision Information

| Changes from 1-08 (2016-Aug-17) to current revision 1-11 (2016-Dec-14) | Page |
|--|------|
| 1-08 (2016-Aug-17) to 1-09 (2016-Dec-05) | |
| Updated Figure 23 | 19 |
| Added Figure 38 | 32 |
| Added Figure 47 | 39 |
| Added Figure 51 | 43 |
| Updated Figure 120 | 96 |
| Updated Figure 121 | 97 |
| Updated Figure 122 | 98 |
| Updated Figure 126 | 103 |
| 1-09 (2016-Dec-05) to 1-10 (2016-Dec-08) | |
| Updated Figure 24 | 20 |
| 1-10 (2016-Dec-08) to 1-11 (2016-Dec-14) | |
| Updated Figure 129 | 103 |

Note(s):

1. Page and figure numbers for the previous version may differ from page and figure numbers in the current revision.
2. Correction of typographical errors is not explicitly mentioned.

Content Guide

| | |
|-----------|---|
| 1 | General Description |
| 1 | Key Benefits & Features |
| 2 | Applications |
| 3 | Block Diagram |
| 5 | Pin Assignments |
| 7 | Absolute Maximum Ratings |
| 9 | Electrical Characteristics |
| 10 | Detailed Description – Power Management Functions |
| 10 | Step Down Converter |
| 11 | Mode Settings |
| 15 | Parameters |
| 19 | Universal IO LDO Regulator |
| 19 | Parameters |
| 23 | Linear Charger |
| 25 | Charging Cycle Description |
| 27 | Stop Charging Conditions |
| 27 | Battery Presence Indication |
| 27 | NTC Supervision |
| 31 | Parameters |
| 32 | Selection of Bypass Capacitors for the Pins VUSB, VSUP_ CHG and VBAT |
| 32 | Current Sinks |
| 33 | Parameters |
| 34 | Detailed Description – System Functions |
| 34 | Start-Up |
| 34 | Normal Start-Up |
| 34 | Parameter |
| 38 | Reset |
| 39 | RESET Reasons |
| 40 | Parameter |
| 41 | Stand-By |
| 41 | Enter Via GPIO |
| 42 | Enter Via SW |
| 42 | Leaving Stand-By |
| 42 | Power OFF |
| 44 | Internal References |
| 44 | Description |
| 44 | Parameter |
| 45 | GPIO Pins |
| 46 | IO Functions |
| 51 | Supervisor |
| 51 | Temperature Supervision |
| 52 | Interrupt Generation |
| 52 | Wire-Serial Control Interface |
| 52 | Feature List |
| 53 | I ² C Protocol |
| 56 | I ² C Parameter |

- 57 Register Description**
 - 61 Detailed Register Description

- 96 Application Information**
- 99 Package Drawings & Markings**
- 103 Ordering & Contact Information**
- 104 RoHS Compliant & ams Green Statement**
- 105 Copyrights & Disclaimer**
- 106 Document Status**
- 107 Revision Information**

Looking for pricing, stock, or lifecycle information?

Click below to explore more details on WIN SOURCE:

- ⊖ [View AS3701A-BWLM-50 on WIN SOURCE](#)
- ⊖ [OSRAM Opto Semiconductors Inc. Information](#)

Optimize Your Supply Chain with WIN SOURCE Solutions

- ✓ Global Sourcing Solution
- ✓ Obsolete Management
- ✓ Cost Control Management
- ✓ Shortage Management
- ✓ Alternative Solution
- ✓ Excess Inventory Management