



SAW Components

Data Sheet B7801





SAW Components

B7801

Low-Loss Filter for Mobile Communication

1960,00 MHz

Data Sheet



Chip Sized SAW Package DCS4A

Features

- Low-loss RF filter for mobile telephone PCS systems, receive path
- Usable passband 60 MHz
- No matching network required for operation at 50 Ω
- Package for **Surface Mounted Technology (SMT)**

Terminals

- Ni, gold-plated

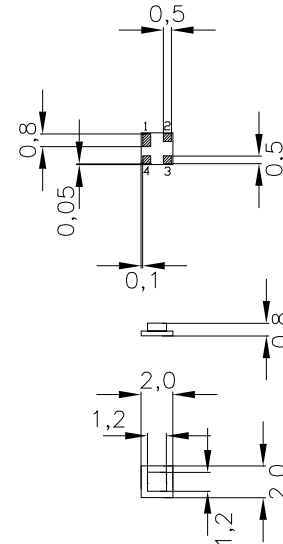

Dimensions in mm, approx. weight 0,01 g

Pin configuration

- 2 Input
- 1 Input - ground
- 3 Output
- 4 Output - ground

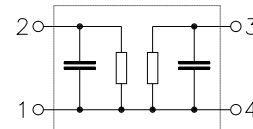

Type	Ordering code	Marking and Package according to	Packing according to
B7801	B39202-B7801-A510	C61157-A7-A63	F61074-V8154-Z000

Electrostatic Sensitive Device (ESD)

Maximum ratings

Operable temperature range	T	- 40/+ 85	°C	source and load impedance 50 Ω peak power of GSM signal, duty cycle 1 : 8 CDMA signal
Storage temperature range	T_{stg}	- 40/+ 85	°C	
DC voltage	V_{DC}	3	V	
Input power max.	P_{IN}	5	dBm	
		0	dBm	



SAW Components

B7801

Low-Loss Filter for Mobile Communication

1960,00 MHz

Data Sheet



Characteristics

Operating temperature range: $T = +25 \pm 2^\circ\text{C}$
 Terminating source impedance: $Z_S = 50 \Omega$
 Terminating load impedance: $Z_L = 50 \Omega$

			min.	typ.	max.	
Center frequency	f_c		—	1960,0	—	MHz
Maximum insertion attenuation	α_{\max}					
		1930,0 ... 1990,0 MHz	—	3,1	3,7	dB
Amplitude ripple (p-p)	$\Delta\alpha$					
		1930,0 ... 1990,0 MHz	—	1,2	1,8	dB
Input VSWR						
		1930,0 ... 1990,0 MHz	—	1,7	2,0	
Output VSWR						
		1930,0 ... 1990,0 MHz	—	1,7	2,0	
Attenuation	α					
		10,0 ... 1500,0 MHz	19,0	21,0	—	dB
		1500,0 ... 1830,0 MHz	23,0	27,0	—	dB
		1830,0 ... 1910,0 MHz	17,0	22,0	—	dB
		2030,0 ... 2070,0 MHz	15,0	28,0	—	dB
		2070,0 ... 2800,0 MHz	21,0	23,0	—	dB
		3000,0 ... 6000,0 MHz	16,0	18,0	—	dB



SAW Components

B7801

Low-Loss Filter for Mobile Communication

1960,00 MHz

Data Sheet



Characteristics

Operating temperature range: $T = -30$ to $+80^{\circ}\text{C}$
 Terminating source impedance: $Z_S = 50\ \Omega$
 Terminating load impedance: $Z_L = 50\ \Omega$

			min.	typ.	max.	
Center frequency	f_c		—	1960,0	—	MHz
Maximum insertion attenuation	α_{\max}					
		1930,0 ... 1990,0 MHz	—	3,6	4,0	dB
Amplitude ripple (p-p)	$\Delta\alpha$					
		1930,0 ... 1990,0 MHz	—	1,8	2,2	dB
Input VSWR						
		1930,0 ... 1990,0 MHz	—	1,7	2,0	
Output VSWR						
		1930,0 ... 1990,0 MHz	—	1,7	2,0	
Attenuation	α					
		10,0 ... 1500,0 MHz	18,0	20,0	—	dB
		1500,0 ... 1830,0 MHz	23,0	27,0	—	dB
		1830,0 ... 1910,0 MHz	10,0	19,0	—	dB
		2030,0 ... 2070,0 MHz	15,0	28,0	—	dB
		2070,0 ... 2800,0 MHz	21,0	23,0	—	dB
		3000,0 ... 6000,0 MHz	16,0	18,0	—	dB



SAW Components

B7801

Low-Loss Filter for Mobile Communication

1960,00 MHz

Data Sheet



Characteristics

Operating temperature range: $T = -30$ to $+85^\circ\text{C}$
 Terminating source impedance: $Z_S = 50\ \Omega$
 Terminating load impedance: $Z_L = 50\ \Omega$

				min.	typ.	max.	
Center frequency		f_c		—	1960,0	—	MHz
Maximum insertion attenuation	1930,0 ... 1990,0	α_{\max}	MHz	—	3,6	4,0	dB
Amplitude ripple (p-p)	1930,0 ... 1990,0	$\Delta\alpha$	MHz	—	1,8	2,2	dB
Input VSWR	1930,0 ... 1990,0		MHz	—	1,7	2,0	
Output VSWR	1930,0 ... 1990,0		MHz	—	1,7	2,0	
Attenuation		α					
	10,0 ... 1500,0		MHz	18,0	20,0	—	dB
	1500,0 ... 1830,0		MHz	23,0	27,0	—	dB
	1830,0 ... 1910,0		MHz	9,0	19,0	—	dB
	2030,0 ... 2070,0		MHz	15,0	28,0	—	dB
	2070,0 ... 2800,0		MHz	21,0	23,0	—	dB
	3000,0 ... 6000,0		MHz	16,0	18,0	—	dB



SAW Components

B7801

Low-Loss Filter for Mobile Communication

1960,00 MHz

Data Sheet



Transfer Function(25° C spec)

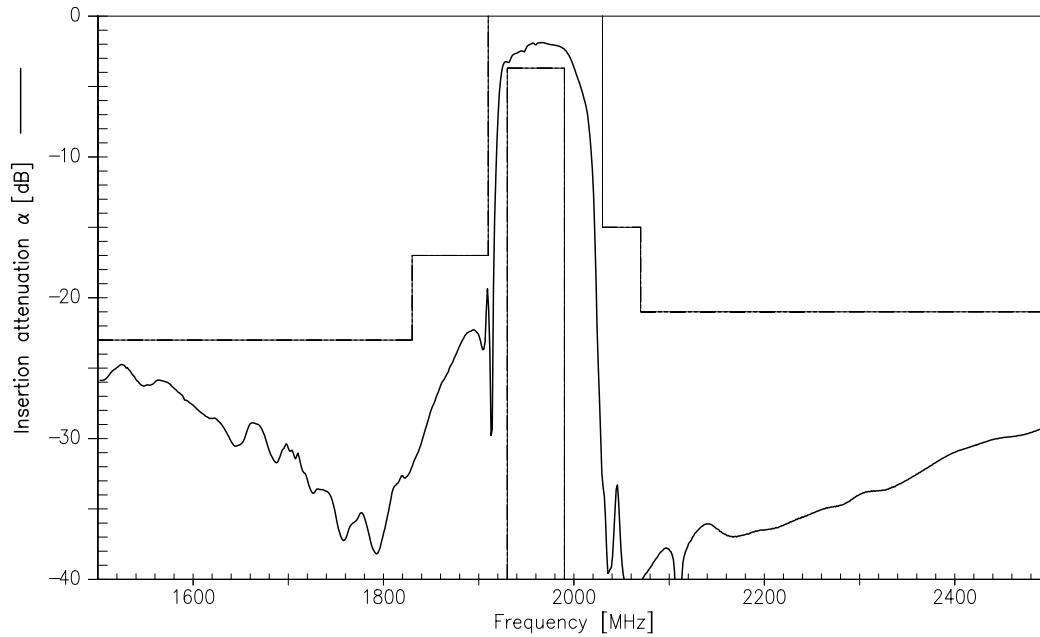

Transfer function (wideband)

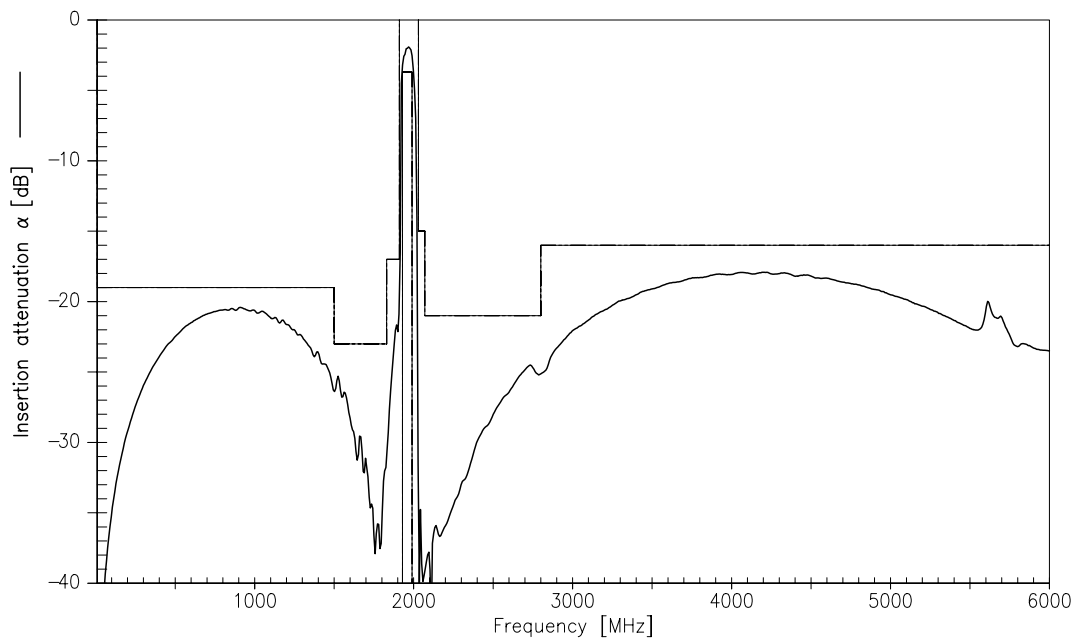



Reflection functions

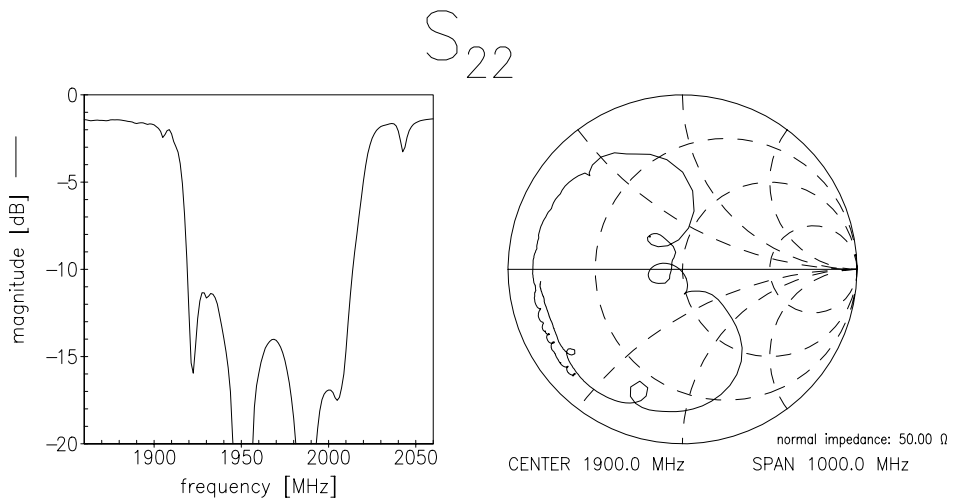
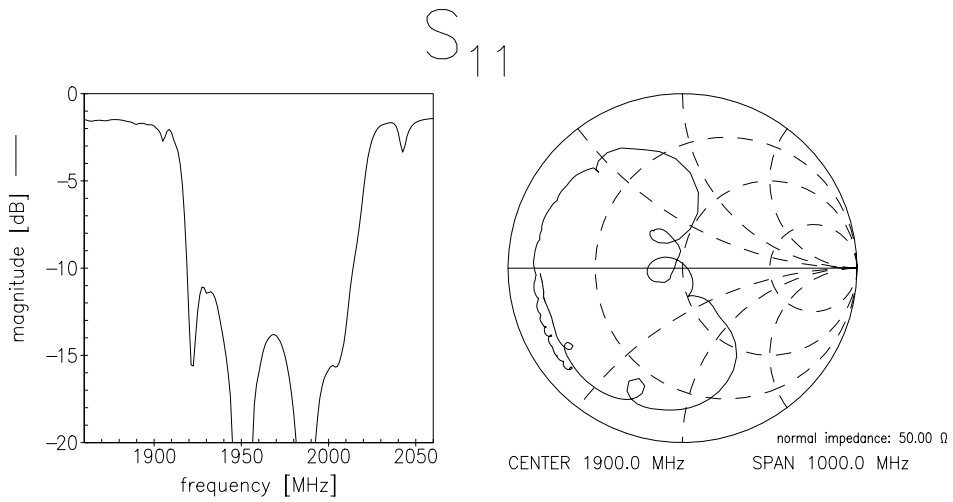



SAW Components

B7801

Low-Loss Filter for Mobile Communication

1960,00 MHz

Data Sheet



Published by EPCOS AG

Corporate Communications, P.O. Box 80 17 09, 81617 Munich, GERMANY

☎ ++49 89 636 09, FAX (0 89) 636-2 26 89

© EPCOS AG 2002. Reproduction, publication and dissemination of this brochure and the information contained therein without EPCOS' prior express consent is prohibited.

Purchase orders are subject to the General Conditions for the Supply of Products and Services of the Electrical and Electronics Industry recommended by the ZVEI (German Electrical and Electronic Manufacturers' Association), unless otherwise agreed.

This brochure replaces the previous edition.

For questions on technology, prices and delivery please contact the Sales Offices of EPCOS AG or the international Representatives.

Due to technical requirements components may contain dangerous substances. For information on the type in question please also contact one of our Sales Offices.

Looking for pricing, stock, or lifecycle information?

Click below to explore more details on WIN SOURCE:

 [View B39202-B7801-A510 on WIN SOURCE](#)

 [EPCOS \(TDK\) Information](#)

Optimize Your Supply Chain with WIN SOURCE Solutions

-  Global Sourcing Solution
-  Obsolete Management
-  Cost Control Management
-  Shortage Management
-  Alternative Solution
-  Excess Inventory Management