



**THE DATASHEET OF  
IRAMX16UP60B-2**



**16A, 600V**

Integrated Power Hybrid IC for  
 Appliance Motor Drive Applications.

**with Internal Shunt Resistor**

### Description

International Rectifier's IRAMX16UP60B is a 16A, 600V Integrated Power Hybrid IC with Internal Shunt Resistor for Appliance Motor Drives applications such as air conditioning systems and compressor drivers as well as for light industrial application. IR's technology offers an extremely compact, high performance AC motor-driver in a single isolated package to simplify design.

This advanced HIC is a combination of IR's low  $V_{CE(on)}$  Punch-Through IGBT technology and the industry benchmark 3 phase high voltage, high speed driver in a fully isolated thermally enhanced package.

A built-in temperature monitor and over-current protection, along with the short-circuit rated IGBTs and integrated under-voltage lockout function, deliver high level of protection and fail-safe operation. Using a Single in line package (SiP2) with full transfer mold structure minimizes PCB space and resolve isolation problems to heatsink.

### Features

- Internal Shunt Resistor
- Integrated Gate Drivers and Bootstrap Diodes
- Temperature Monitor
- Low  $V_{CE(on)}$  Non Punch Through IGBT Technology
- Undervoltage lockout for all channels
- Matched propagation delay for all channels
- Schmitt-triggered input logic
- Cross-conduction prevention logic
- Lower di/dt gate driver for better noise immunity
- Motor Power range 0.75~2.2kW / 85~253 Vac
- Isolation 2000V<sub>RMS</sub> min
- UL certification pending (UL number: E78996)



### Absolute Maximum Ratings

Parameter	Description	Value	Units
$V_{CES} / V_{RRM}$	IGBT/Diode Blocking Voltage	600	V
$V^+$	Positive Bus Input Voltage	450	
$I_O @ T_C=25^\circ C$	RMS Phase Current (Note 1)	16	A
$I_O @ T_C=100^\circ C$	RMS Phase Current (Note 1)	8	
$I_O$	Pulsed RMS Phase Current (Note 2)	30	
$F_{PWM}$	PWM Carrier Frequency	20	kHz
$P_D$	Power dissipation per IGBT @ $T_C = 25^\circ C$	31	W
$V_{ISO}$	Isolation Voltage (1min)	2000	V <sub>RMS</sub>
$T_J$ (IGBT & Diodes)	Operating Junction temperature Range	-40 to +150	°C
$T_J$ (Driver IC)	Operating Junction temperature Range	-40 to +150	
T	Mounting torque Range (M3 screw)	0.5 to 1.0	Nm

Note 1: Sinusoidal Modulation at  $V^+=400V$ ,  $T_J=150^\circ C$ ,  $F_{PWM}=16kHz$ , Modulation Depth=0.8, PF=0.6, See Figure 3.

Note 2:  $t_p < 100ms$ ;  $T_C=25^\circ C$ ;  $F_{PWM}=16kHz$ . Limited by  $I_{BUS-ITRIP}$ , see Table "Inverter Section Electrical Characteristics"

# IRAMX16UP60B

## Internal Electrical Schematic - IRAMX16UP60B

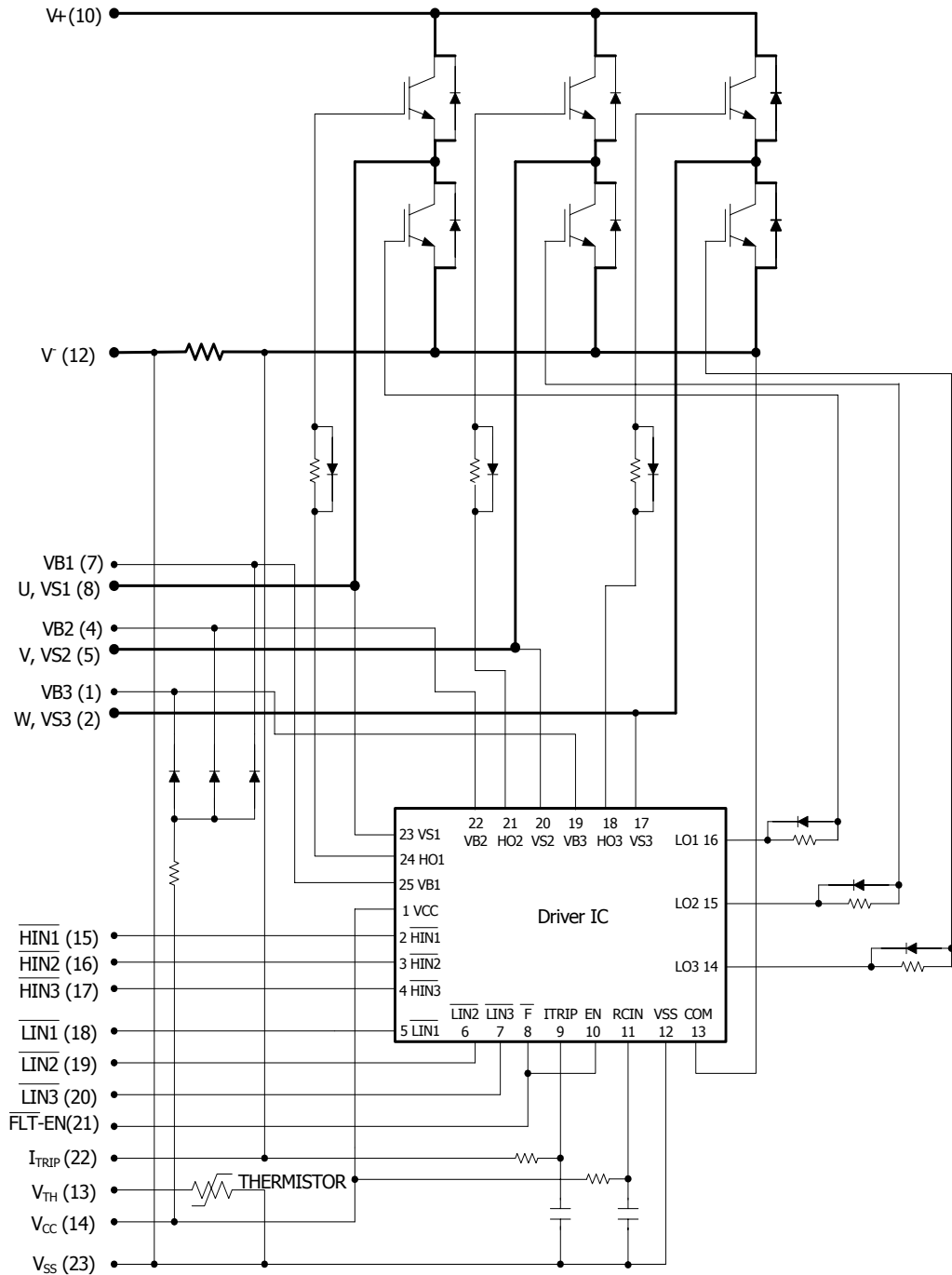

### Absolute Maximum Ratings (Continued)

All voltages are absolute referenced to COM/I<sub>TRIP</sub>.

Symbol	Parameter	Min	Max	Units	Conditions
I <sub>BDF</sub>	Bootstrap Diode Peak Forward Current	---	4.5	A	t <sub>p</sub> = 10ms, T <sub>J</sub> = 150°C, T <sub>C</sub> =100°C
P <sub>BR Peak</sub>	Bootstrap Resistor Peak Power (Single Pulse)	---	25.0	W	t <sub>p</sub> =100μs, T <sub>C</sub> =100°C ESR / ERJ series
V <sub>S1,2,3</sub>	High side floating supply offset voltage	V <sub>B1,2,3</sub> - 25	V <sub>B1,2,3</sub> +0.3	V	
V <sub>B1,2,3</sub>	High side floating supply voltage	-0.3	600	V	
V <sub>CC</sub>	Low Side and logic fixed supply voltage	-0.3	20	V	
V <sub>IN</sub> , V <sub>EN</sub> , V <sub>ITRIP</sub>	Input voltage LIN, HIN, EN, I <sub>TRIP</sub>	-0.3	Lower of (V <sub>SS</sub> +15V) or V <sub>CC</sub> +0.3V	V	

### Inverter Section Electrical Characteristics @T<sub>J</sub>= 25°C

Symbol	Parameter	Min	Typ	Max	Units	Conditions
V <sub>(BR)CES</sub>	Collector-to-Emitter Breakdown Voltage	600	---	---	V	V <sub>IN</sub> =5V, I <sub>C</sub> =250μA
ΔV <sub>(BR)CES</sub> / ΔT	Temperature Coeff. Of Breakdown Voltage	---	0.3	---	V/°C	V <sub>IN</sub> =5V, I <sub>C</sub> =1.0mA (25°C - 150°C)
V <sub>CE(ON)</sub>	Collector-to-Emitter Saturation Voltage	---	1.55	1.85	V	I <sub>C</sub> =8A, V <sub>CC</sub> =15V
		---	1.80	2.10		I <sub>C</sub> =8A, V <sub>CC</sub> =15V, T <sub>J</sub> =150°C
I <sub>CES</sub>	Zero Gate Voltage Collector Current	---	5	80	μA	V <sub>IN</sub> =5V, V <sup>+</sup> =600V
		---	165	---		V <sub>IN</sub> =5V, V <sup>+</sup> =600V, T <sub>J</sub> =150°C
V <sub>FM</sub>	Diode Forward Voltage Drop	---	2.0	2.4	V	I <sub>C</sub> =8A
		---	1.4	1.9		I <sub>C</sub> =8A, T <sub>J</sub> =150°C
V <sub>BDFM</sub>	Bootstrap Diode Forward Voltage Drop	--	--	1.25	V	I <sub>F</sub> =1A
		---	---	1.10		I <sub>F</sub> =1A, T <sub>J</sub> =125°C
R <sub>BR</sub>	Bootstrap Resistor Value	---	22	---	Ω	T <sub>J</sub> =25°C
ΔR <sub>BR</sub> /R <sub>BR</sub>	Bootstrap Resistor Tolerance	---	---	±5	%	T <sub>J</sub> =25°C
I <sub>BUS_TRIP</sub>	Current Protection Threshold (positive going)	21	---	28	A	T <sub>J</sub> =-40°C to 125°C See Fig. 2

## Inverter Section Switching Characteristics @ $T_J = 25^\circ\text{C}$

Symbol	Parameter	Min	Typ	Max	Units	Conditions
$E_{ON}$	Turn-On Switching Loss	---	315	435	$\mu\text{J}$	$I_C=8\text{A}$ , $V^+=400\text{V}$ $V_{CC}=15\text{V}$ , $L=2\text{mH}$ Energy losses include "tail" and diode reverse recovery
$E_{OFF}$	Turn-Off Switching Loss	---	150	180		
$E_{TOT}$	Total Switching Loss	---	465	615		
$E_{REC}$	Diode Reverse Recovery energy	---	30	60		
$t_{RR}$	Diode Reverse Recovery time	---	70	90	ns	See CT1
$E_{ON}$	Turn-on Switching Loss	---	500	700	$\mu\text{J}$	$I_C=8\text{A}$ , $V^+=400\text{V}$ $V_{CC}=15\text{V}$ , $L=2\text{mH}$ , $T_J=150^\circ\text{C}$ Energy losses include "tail" and diode reverse recovery
$E_{OFF}$	Turn-off Switching Loss	---	270	335		
$E_{TOT}$	Total Switching Loss	---	770	1035		
$E_{REC}$	Diode Reverse Recovery energy	---	60	100		
$t_{RR}$	Diode Reverse Recovery time	---	120	150	ns	See CT1
$Q_G$	Turn-On IGBT Gate Charge	---	56	84	nC	$I_C=15\text{A}$ , $V^+=400\text{V}$ , $V_{GE}=15\text{V}$
RBSOA	Reverse Bias Safe Operating Area	FULL SQUARE				$T_J=150^\circ\text{C}$ , $I_C=8\text{A}$ , $V_P=600\text{V}$ $V^+=450\text{V}$ $V_{CC}=+15\text{V}$ to $0\text{V}$ See CT3
SCSOA	Short Circuit Safe Operating Area	10	---	---	$\mu\text{s}$	$T_J=150^\circ\text{C}$ , $V_P=600\text{V}$ , $V^+=360\text{V}$ , $V_{CC}=+15\text{V}$ to $0\text{V}$ See CT2
$I_{CSC}$	Short Circuit Collector Current	---	140	---	A	$T_J=150^\circ\text{C}$ , $V_P=600\text{V}$ , $t_{SC}<10\mu\text{s}$ $V^+=360\text{V}$ , $V_{GE}=15\text{V}$ $V_{CC}=+15\text{V}$ to $0\text{V}$ See CT2

## Recommended Operating Conditions Driver Function

The Input/Output logic timing diagram is shown in Figure 1. For proper operation the device should be used within the recommended conditions. All voltages are absolute referenced to COM/ $I_{TRIP}$ . The  $V_S$  offset is tested with all supplies biased at 15V differential (Note 3)

Symbol	Definition	Min	Max	Units
$V_{B1,2,3}$	High side floating supply voltage	$V_S+12$	$V_S+20$	V
$V_{S1,2,3}$	High side floating supply offset voltage	Note 4	450	
$V_{CC}$	Low side and logic fixed supply voltage	12	20	V
$V_{ITRIP}$	$I_{TRIP}$ input voltage	$V_{SS}$	$V_{SS}+5$	
$V_{IN}$	Logic input voltage LIN, HIN	$V_{SS}$	$V_{SS}+4$	V
$V_{EN}$	Logic input voltage EN	$V_{SS}$	$V_{SS}+5$	V

Note 3: For more details, see IR21363 data sheet

Note 4: Logic operational for  $V_S$  from COM-5V to COM+600V. Logic state held for  $V_S$  from COM-5V to COM- $V_{BS}$ . (please refer to DT97-3 for more details)

## Static Electrical Characteristics Driver Function

$V_{BIAS}$  ( $V_{CC}$ ,  $V_{BS1,2,3}$ )=15V, unless otherwise specified. The  $V_{IN}$  and  $I_{IN}$  parameters are referenced to COM/ $I_{TRIP}$  and are applicable to all six channels. (Note 3)

Symbol	Definition	Min	Typ	Max	Units
$V_{INH}$ , $V_{ENH}$	Logic "0" input voltage	3.0	---	---	V
$V_{INL}$ , $V_{ENL}$	Logic "1" input voltage	---	---	0.8	V
$V_{CCUV+}$ , $V_{BSUV+}$	$V_{CC}$ and $V_{BS}$ supply undervoltage Positive going threshold	10.6	11.1	11.6	V
$V_{CCUV-}$ , $V_{BSUV-}$	$V_{CC}$ and $V_{BS}$ supply undervoltage Negative going threshold	10.4	10.9	11.4	V
$V_{CCUVH}$ , $V_{BSUVH}$	$V_{CC}$ and $V_{BS}$ supply undervoltage lock-out hysteresis	---	0.2	---	V
$V_{IN,Clamp}$	Input Clamp Voltage (HIN, LIN, $I_{TRIP}$ ) $I_{IN}=10\mu A$	4.9	5.2	5.5	V
$I_{QBS}$	Quiescent $V_{BS}$ supply current $V_{IN}=0V$	---	---	165	$\mu A$
$I_{QCC}$	Quiescent $V_{CC}$ supply current $V_{IN}=0V$	---	---	3.35	mA
$I_{LK}$	Offset Supply Leakage Current	---	---	60	$\mu A$
$I_{IN+}$ , $I_{EN+}$	Input bias current $V_{IN}=5V$	---	200	300	$\mu A$
$I_{IN-}$ , $I_{EN-}$	Input bias current $V_{IN}=0V$	---	100	220	$\mu A$
$I_{TRIP+}$	$I_{TRIP}$ bias current $V_{ITRIP}=5V$	---	30	100	$\mu A$
$I_{TRIP-}$	$I_{TRIP}$ bias current $V_{ITRIP}=0V$	---	0	1	$\mu A$
$V(I_{TRIP})$	$I_{TRIP}$ threshold Voltage	440	490	540	mV
$V(I_{TRIP}, HYS)$	$I_{TRIP}$ Input Hysteresis	---	70	---	mV
$R_{ON,FLT}$	Fault Output ON Resistance	---	50	100	ohm

## Dynamic Electrical Characteristics

Driver only timing unless otherwise specified.

Symbol	Parameter	Min	Typ	Max	Units	Conditions
$T_{ON}$	Input to Output propagation turn-on delay time (see fig.11)	---	590	---	ns	$V_{CC}=V_{BS}= 15V$ , $I_C=8A$ , $V^+=400V$
$T_{OFF}$	Input to Output propagation turn-off delay time (see fig. 11)	---	660	---	ns	
$T_{FLIN}$	Input Filter time (HIN, LIN)	100	200	---	ns	$V_{IN}=0$ & $V_{IN}=5V$
$T_{BLT-Trip}$	$I_{TRIP}$ Blanking Time	100	150	---	ns	$V_{IN}=0$ & $V_{IN}=5V$
$D_T$	Dead Time ( $V_{BS}=V_{DD}=15V$ )	220	290	360	ns	$V_{BS}=V_{CC}=15V$
$M_T$	Matching Propagation Delay Time (On & Off)	---	40	75	ns	$V_{CC}= V_{BS}= 15V$ , external dead time> 400ns
$T_{ITrip}$	$I_{Trip}$ to six switch to turn-off propagation delay (see fig. 2)	---	---	1.75	$\mu s$	$V_{CC}=V_{BS}= 15V$ , $I_C=8A$ , $V^+=400V$
$T_{FLT-CLR}$	Post $I_{Trip}$ to six switch to turn-off clear time (see fig. 2)	---	7.7	---	ms	$T_C = 25^\circ C$
		---	6.7	---		$T_C = 100^\circ C$

# IRAMX16UP60B

## Thermal and Mechanical Characteristics

Symbol	Parameter	Min	Typ	Max	Units	Conditions
$R_{th(J-C)}$	Thermal resistance, per IGBT	---	3.5	4.0	°C/W	Flat, greased surface. Heatsink compound thermal conductivity 1W/mK
$R_{th(J-C)}$	Thermal resistance, per Diode	---	5.0	5.5		
$R_{th(C-S)}$	Thermal resistance, C-S	---	0.1	---		
$C_D$	Creepage Distance	3.2	---	---	mm	See outline Drawings

## Internal Current Sensing Resistor - Shunt Characteristics

Symbol	Parameter	Min	Typ	Max	Units	Conditions
$R_{Shunt}$	Resistance	17.9	18.1	18.3	mΩ	$T_C = 25^\circ C$
$T_{Coeff}$	Temperature Coefficient	0	---	200	ppm/°C	
$P_{Shunt}$	Power Dissipation	---	---	3.0	W	$-40^\circ C < T_C < 100^\circ C$
$T_{Range}$	Temperature Range	-40	---	125	°C	

## Internal NTC - Thermistor Characteristics

Parameter	Definition	Min	Typ	Max	Units	Conditions
$R_{25}$	Resistance	97	100	103	kΩ	$T_C = 25^\circ C$
$R_{125}$	Resistance	2.25	2.52	2.80	kΩ	$T_C = 125^\circ C$
B	B-constant (25-50°C)	4165	4250	4335	k	$R_2 = R_1 e^{[B(1/T_2 - 1/T_1)]}$
Temperature Range		-40		125	°C	
Typ. Dissipation constant			1		mW/°C	$T_C = 25^\circ C$

## Input-Output Logic Level Table

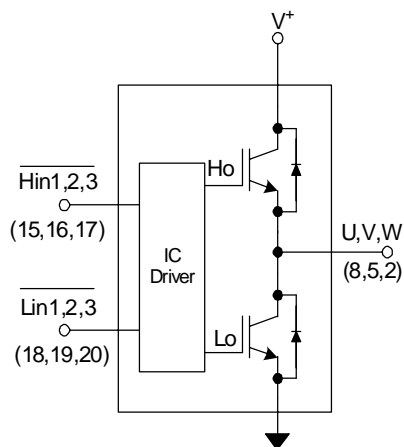

FLT- EN	$I_{TRIP}$	$\overline{HIN1,2,3}$	$\overline{LIN1,2,3}$	U,V,W
1	0	0	1	$V^+$
1	0	1	0	0
1	0	1	1	Off
1	1	X	X	Off
0	X	X	X	Off

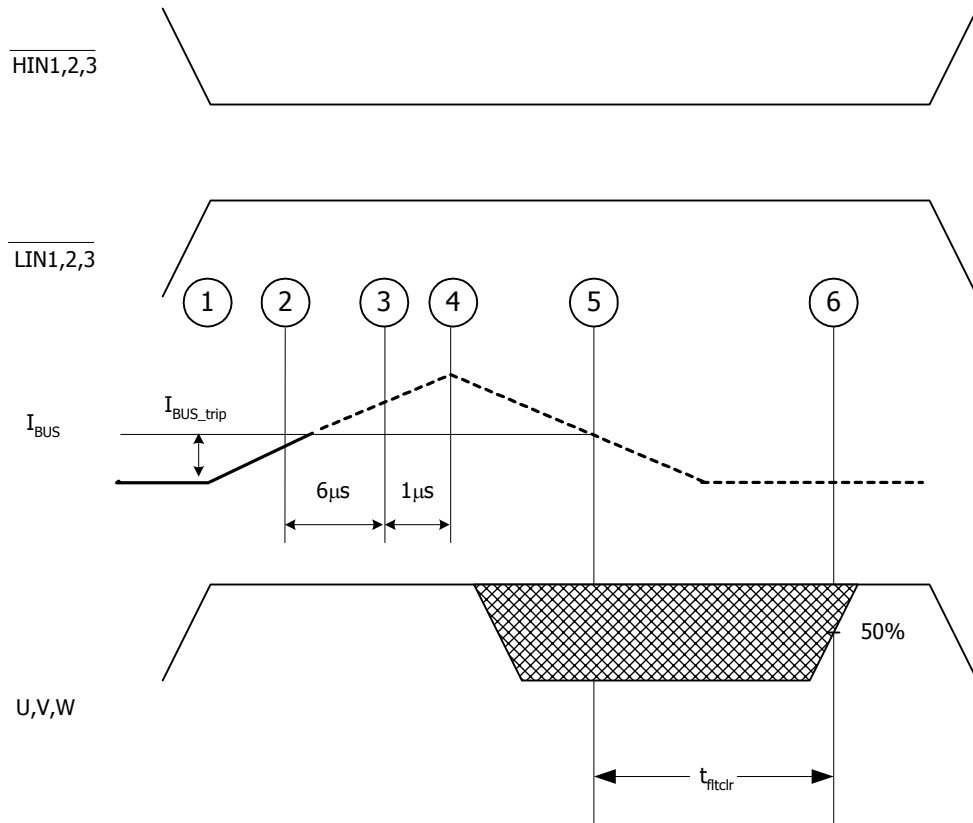

Sequence of events:

- 1-2) Current begins to rise
- 2) Current reaches  $I_{BUS\_Trip}$  level
- 2-3) Current is higher than  $I_{BUS\_Trip}$  for at least  $6\mu s$ . This value is the worst-case condition with very low over-current. In case of high current (short circuit), the actual delay will be smaller.
- 3-4) Delay between driver identification of over-current condition and disabling of all outputs
- 4) Current starts decreasing, eventually reaching 0
- 5) Current goes below  $I_{BUS\_trip}$ , the driver starts its auto-reset sequence
- 6) Driver is automatically reset and normal operation can resume (over-current condition must be removed by the time the drivers automatically resets itself)

Figure 2.  $I_{Trip}$  Timing Waveform

Note 5: The shaded area indicates that both high-side and low-side switches are off and therefore the half-bridge output voltage would be determined by the direction of current flow in the load.

# IRAMX16UP60B

## Module Pin-Out Description

Pin	Name	Description
1	$V_{B3}$	High Side Floating Supply Voltage 3
2	$W, V_{S3}$	Output 3 - High Side Floating Supply Offset Voltage
3	NA	none
4	$V_{B2}$	High Side Floating Supply voltage 2
5	$V, V_{S2}$	Output 2 - High Side Floating Supply Offset Voltage
6	NA	none
7	$V_{B1}$	High Side Floating Supply voltage 1
8	$U, V_{S1}$	Output 1 - High Side Floating Supply Offset Voltage
9	NA	none
10	$V^+$	Positive Bus Input Voltage
11	NA	none
12	$V^-$	Negative Bus Input Voltage
13	$V_{TH}$	Temperature Feedback
14	$V_{CC}$	+15V Main Supply
15	$\overline{H_{IN1}}$	Logic Input High Side Gate Driver - Phase 1
16	$\overline{H_{IN2}}$	Logic Input High Side Gate Driver - Phase 2
17	$\overline{H_{IN3}}$	Logic Input High Side Gate Driver - Phase 3
18	$\overline{L_{IN1}}$	Logic Input Low Side Gate Driver - Phase 1
19	$\overline{L_{IN2}}$	Logic Input Low Side Gate Driver - Phase 2
20	$\overline{L_{IN3}}$	Logic Input Low Side Gate Driver - Phase 3
21	FAULT	Fault Indicator
22	$I_{TRIP}$	Current Sense and Itrip Pin
23	$V_{SS}$	Negative Main Supply

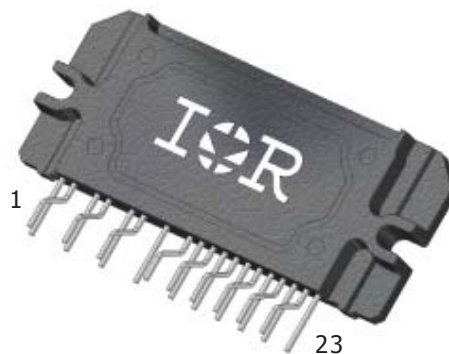

## Typical Application Connection IRAMX16UP60B

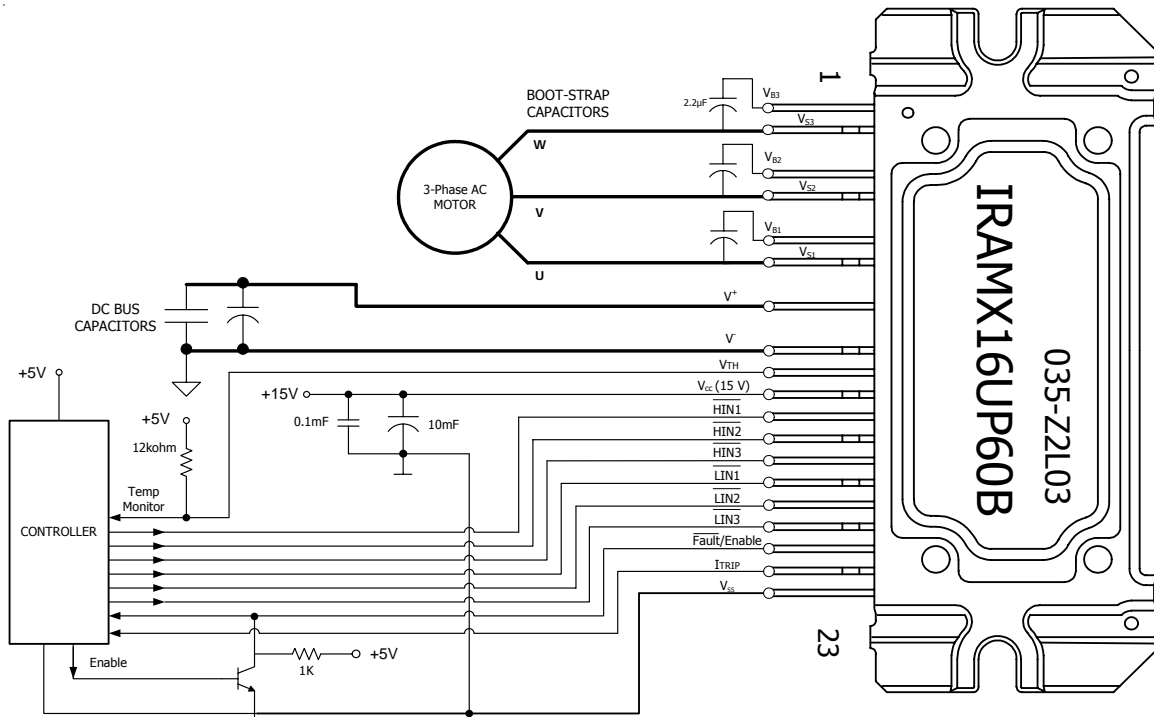

1. Electrolytic bus capacitors should be mounted as close to the module bus terminals as possible to reduce ringing and EMI problems. Additional high frequency ceramic capacitor mounted close to the module pins will further improve performance.
2. In order to provide good decoupling between  $V_{CC}-V_{SS}$  and  $V_{B1,2,3}-V_{S1,2,3}$  terminals, the capacitors shown connected between these terminals should be located very close to the module pins. Additional high frequency capacitors, typically  $0.1\mu F$ , are strongly recommended.
3. Value of the boot-strap capacitors depends upon the switching frequency. Their selection should be made based on IR design tip DN 98-2a, application note AN-1044 or Figure 9. Bootstrap capacitor value must be selected to limit the power dissipation of the internal resistor in series with the  $V_{CC}$ . (see maximum ratings Table on page 3).
4. Current sense signal can be obtained from pin 20 and pin 23. Care should be taken to avoid having inverter current flowing through pin 22 to maintain required current measurement accuracy
5. After approx. 8ms the FAULT is reset. (see Dynamic Characteristics Table on page 5).
6. PWM generator must be disabled within Fault duration to guarantee shutdown of the system, overcurrent condition must be cleared before resuming operation.
7. Fault/Enable pin must be pulled-up to +5V.

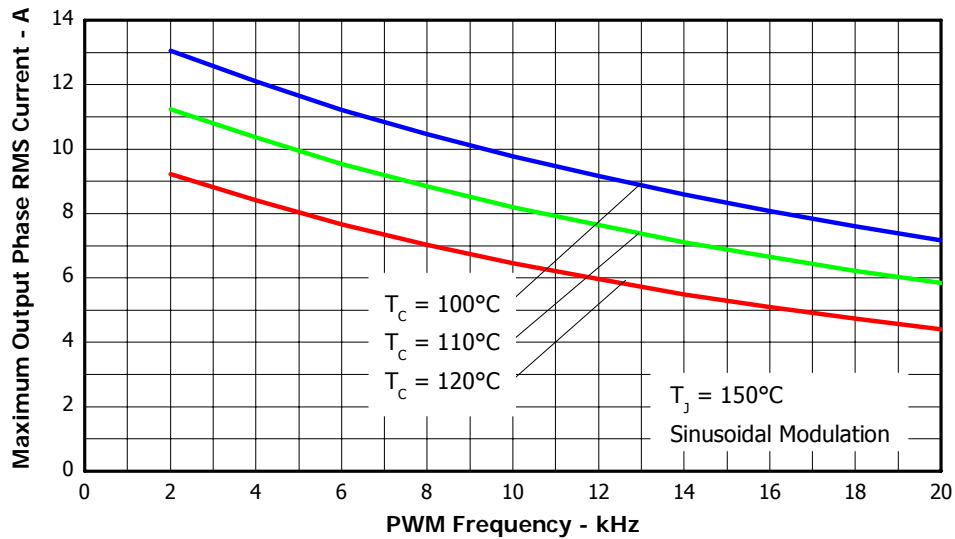

Figure 3. Maximum Sinusoidal Phase Current vs. PWM Switching Frequency  
 $V^+=400\text{V}$  ,  $T_j=150^\circ\text{C}$ , Modulation Depth=0.8, PF=0.6

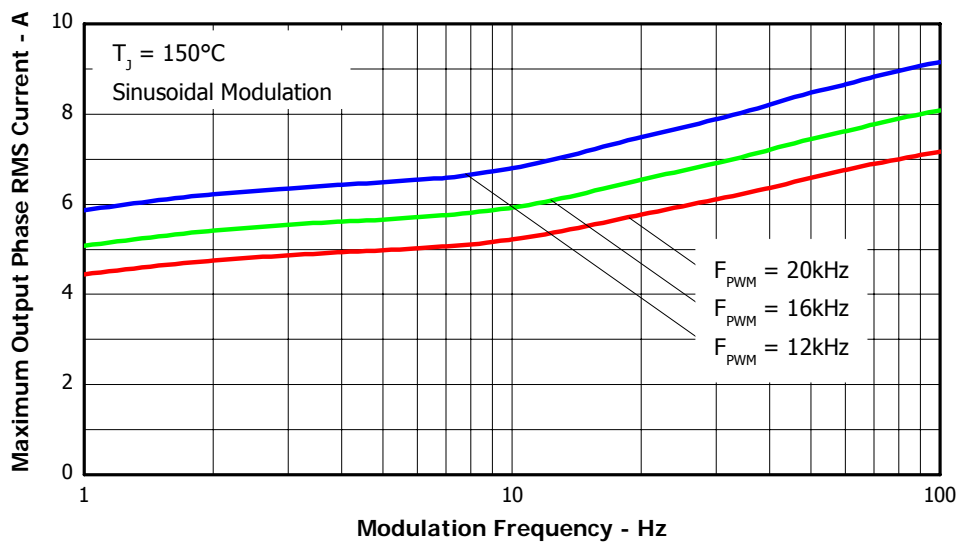

Figure 4. Maximum Sinusoidal Phase Current vs. Modulation Frequency  
 $V^+=400\text{V}$ ,  $T_j=150^\circ\text{C}$ ,  $T_c=100^\circ\text{C}$ , Modulation Depth=0.8, PF=0.6

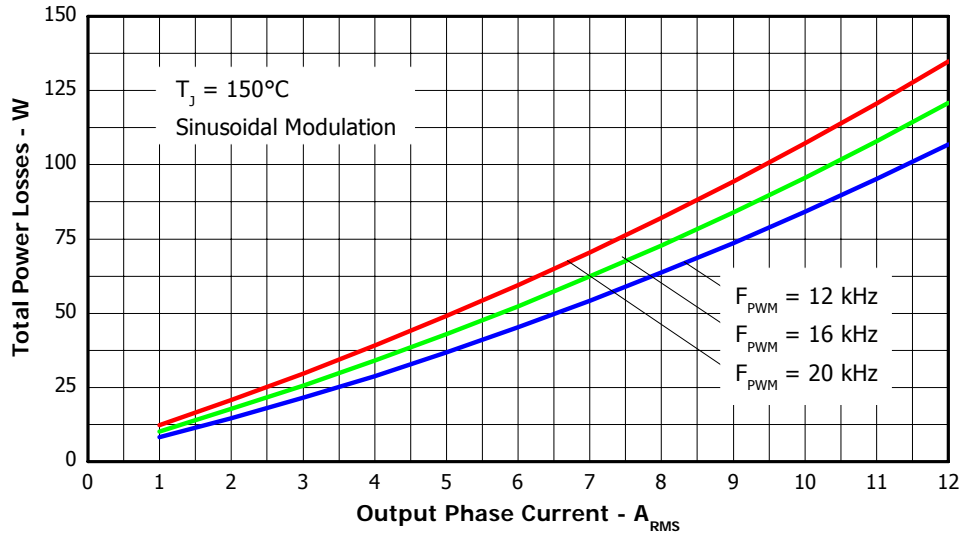

Figure 5. Total Power Losses vs. PWM Switching Frequency, Sinusoidal modulation  
 $V^+ = 400V$ ,  $T_J = 150^\circ C$ , Modulation Depth=0.8, PF=0.6

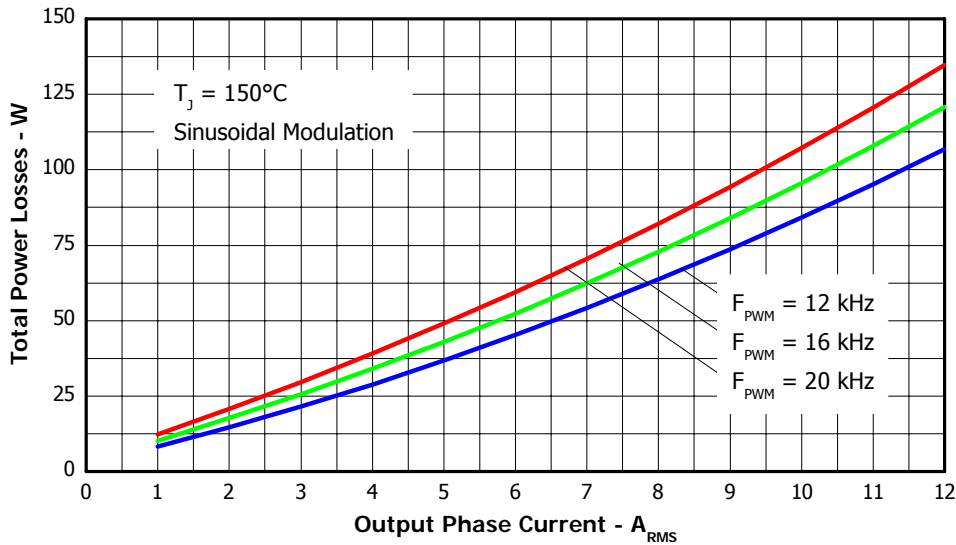

Figure 6. Total Power Losses vs. Output Phase Current, Sinusoidal modulation  
 $V_{BUS} = 400V$ ,  $T_J = 150^\circ C$ , Modulation Depth=0.8, PF=0.6

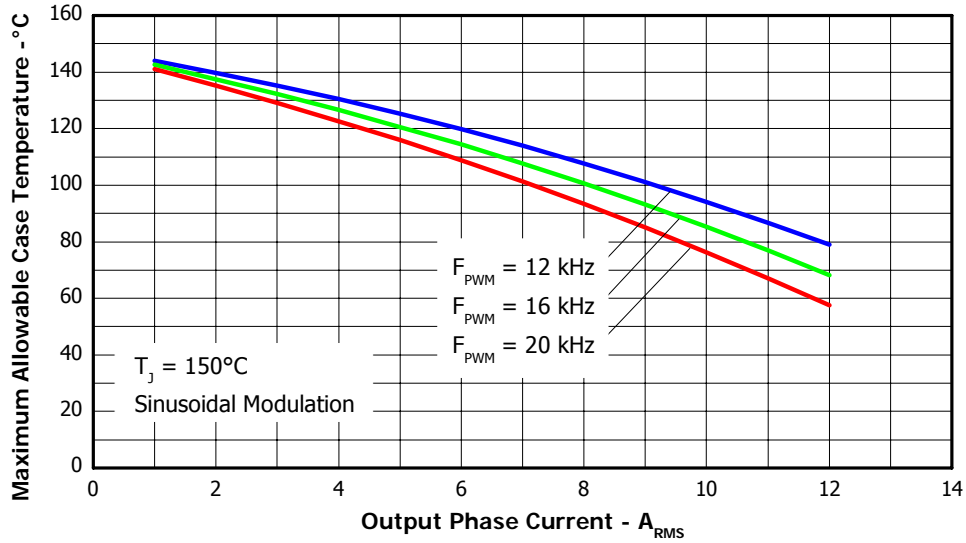

Figure 7. Maximum Allowable Case temperature vs. Output RMS Current per Phase

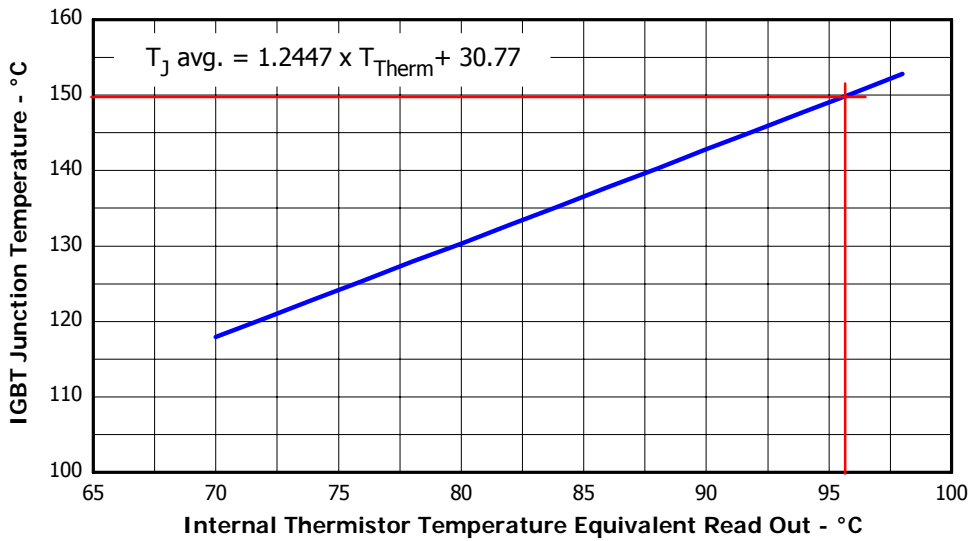

Figure 8. Estimated Maximum IGBT Junction Temperature vs. Thermistor Temperature

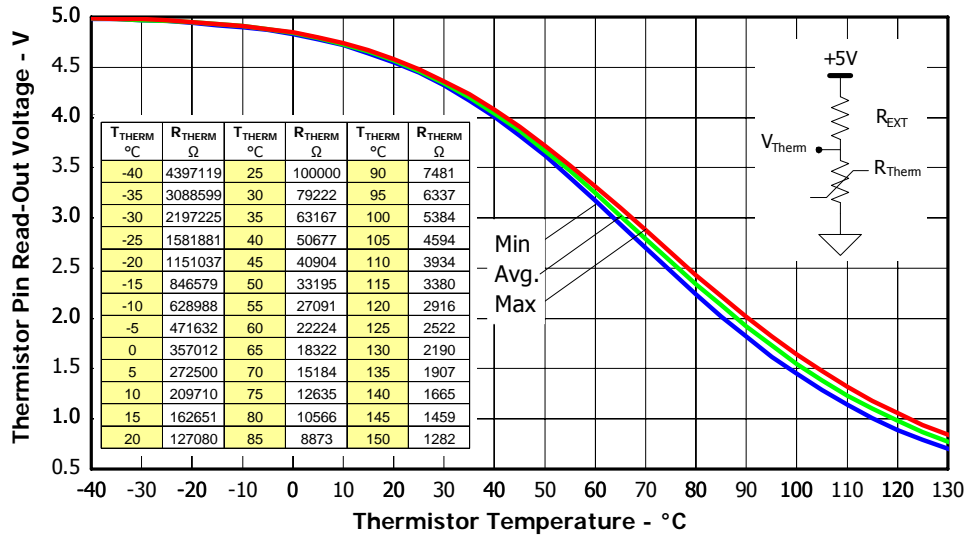

Figure 9. Thermistor Readout vs. Temperature (12kohm pull-up resistor, 5V) and Nominal Thermistor Resistance values vs. Temperature Table.

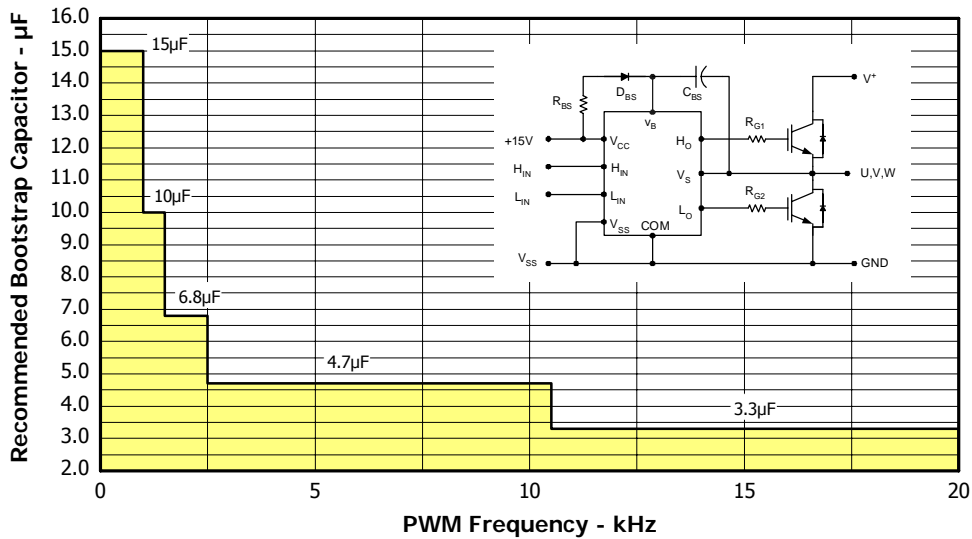

Figure 10. Recommended Bootstrap Capacitor Value vs. Switching Frequency

Figure 11. Switching Parameter Definitions

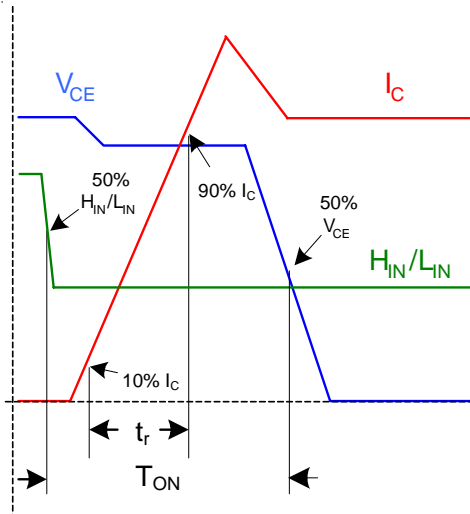

Figure 11a. Input to Output Propagation turn-on Delay Time

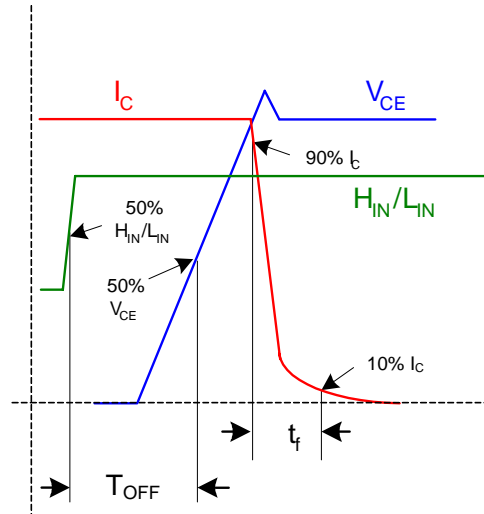

Figure 11b. Input to Output Propagation turn-off Delay Time

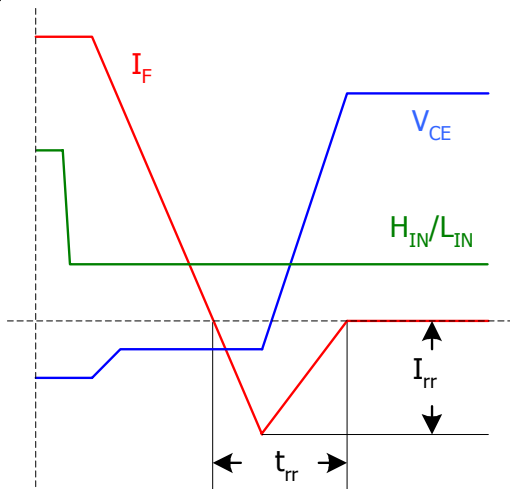

Figure 11c. Diode Reverse Recovery

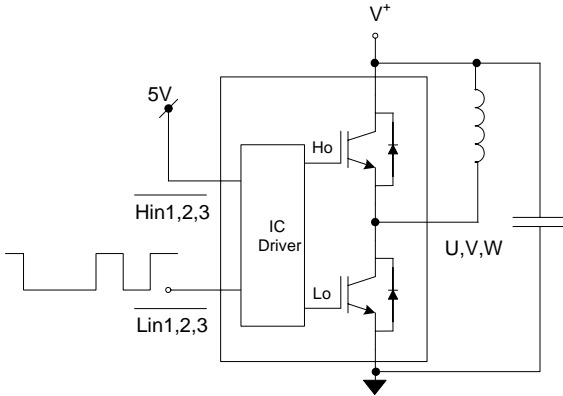

Figure CT1. Switching Loss Circuit

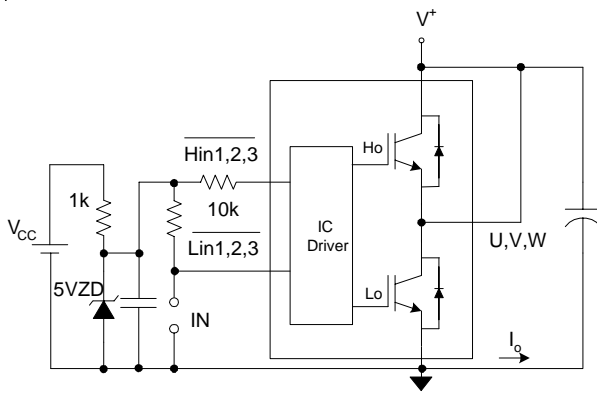
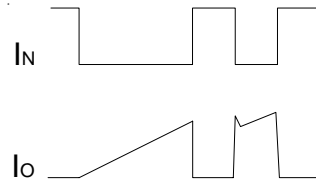

Figure CT2. S.C.SOA Circuit

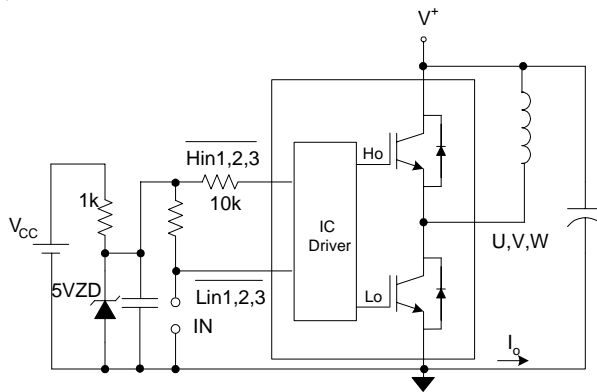
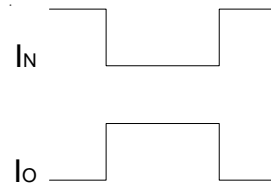
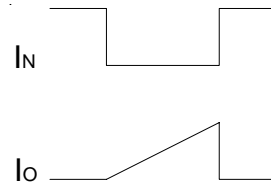
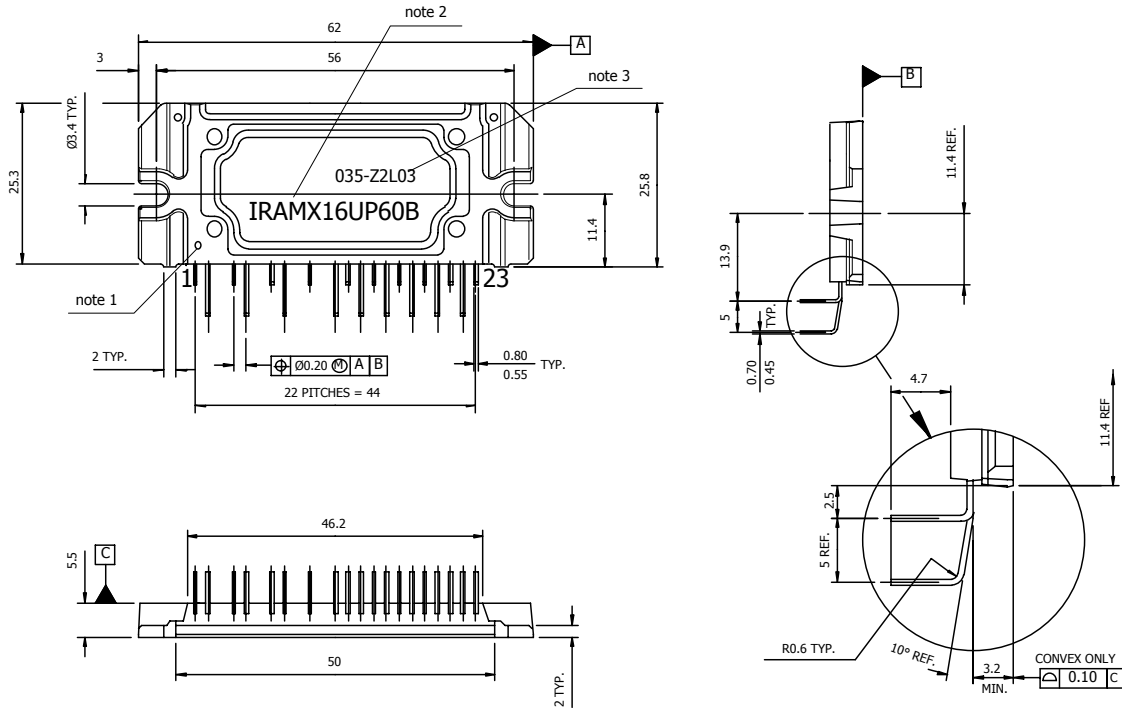

Figure CT3. R.B.SOA Circuit





## Package Outline IRAMX16UP60B-2



**Notes:**

Dimensions in mm

- 1- Marking for pin 1 identification
- 2- Product Part Number
- 3- Lot and Date code marking
- 4- Convex only 0.15mm typical
- 5- Tolerances  $\pm 0.5\text{mm}$ , unless otherwise stated

For mounting instruction see AN-1049

## Looking for pricing, stock, or lifecycle information?

Click below to explore more details on WIN SOURCE:

 [View IRAMX16UP60B-2 on WIN SOURCE](#)

 [Infineon Technologies](#) Information

## Optimize Your Supply Chain with WIN SOURCE Solutions

-  Global Sourcing Solution
-  Obsolete Management
-  Cost Control Management
-  Shortage Management
-  Alternative Solution
-  Excess Inventory Management