



**THE DATASHEET OF  
PTN3365BSMP**



# PTN3365

Enhanced performance HDMI/DVI level shifter with active DDC buffer, supporting 3 Gbit/s operation

Rev. 1.1 — 28 July 2015

Product data sheet

## 1. General description

---

PTN3365 is a high-speed level shifter device which converts four lanes of low-swing AC-coupled differential input signals to DVI v1.0 and HDMI v1.4b compliant open-drain current-steering differential output signals, up to 3.0 Gbit/s per lane to support 36-bit deep color mode, 4K × 2K video format or 3D video data transport. Each of these lanes provides a level-shifting differential buffer to translate from low-swing AC-coupled differential signaling on the source side, to TMDS-type DC-coupled differential current-mode signaling terminated into 50 Ω to 3.3 V on the sink side. Additionally, PTN3365 provides a single-ended active buffer for voltage translation of the HPD signal from 5 V on the sink side to 3.3 V on the source side and provides a channel with active buffering and level shifting of the DDC channel (consisting of a clock and a data line) between 3.3 V source-side and 5 V sink-side. The DDC channel is implemented using active I<sup>2</sup>C-bus buffer technology providing capacitive isolation, redriving and level shifting as well as disablement (isolation between source and sink) of the clock and data lines.

The low-swing AC-coupled differential input signals to PTN3365 typically come from a display source with multi-mode I/O, which supports multiple display standards, for example, DisplayPort, HDMI and DVI. While the input differential signals are configured to carry DVI or HDMI coded data, they do not comply with the electrical requirements of the DVI v1.0 or HDMI v1.4b specification. By using PTN3365, chip set vendors are able to implement such reconfigurable I/Os on multi-mode display source devices, allowing the support of multiple display standards while keeping the number of chip set I/O pins low. See [Figure 1](#).

PTN3365 features low-swing self-biasing differential inputs which are compliant to the electrical specifications of *DisplayPort Standard v1.2* and/or *PCI Express Standard v1.1*, and open-drain current-steering differential outputs compliant to DVI v1.0 and HDMI v1.4b electrical specifications. The I<sup>2</sup>C-bus channel actively buffers as well as level-translates the DDC signals for optimal capacitive isolation. PTN3365 also supports power-saving modes in order to minimize current consumption when no display is active or connected.

PTN3365 is a full-featured HDMI and DVI level shifter.

PTN3365 is powered from a single 3.3 V power supply consuming a small amount of power (230 mW typical) and is offered in a 32-terminal HVQFN32 package.



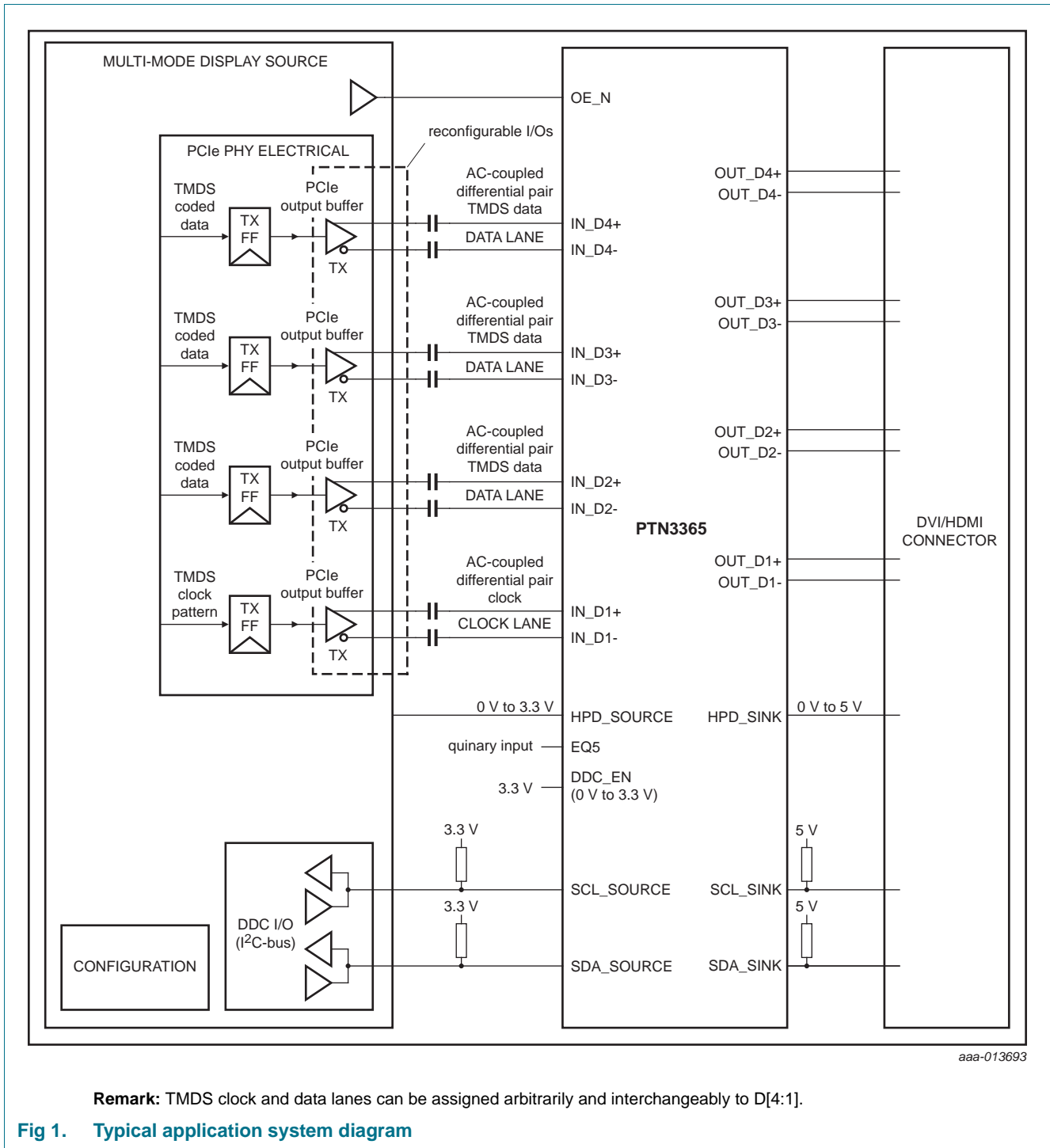

## 2. Features and benefits

### 2.1 High-speed TMDS level shifting

- Converts four lanes of low-swing AC-coupled differential input signals to DVI v1.0 and HDMI v1.4b compliant open-drain current-steering differential output signals
- TMDS level shifting operation up to 3.0 Gbit/s per lane supporting 4K × 2K and 3D video formats
- Programmable equalizer
- Integrated 50 Ω termination resistors for self-biasing differential inputs
- Back-current safe outputs to disallow current when device power is off and monitor is on
- Disable feature to turn off TMDS inputs and outputs and to enter low-power state

### 2.2 DDC level shifting

- Integrated DDC buffering and level shifting (3.3 V source to 5 V sink side)
- Rise time accelerator on sink-side DDC ports
- 0 Hz to 400 kHz I<sup>2</sup>C-bus clock frequency
- Back-power safe sink-side terminals to disallow backdrive current when power is off or when DDC is not enabled

### 2.3 HPD level shifting

- HPD non-inverting level shift from 0 V on the sink side to 0 V on the source side, or from 5 V on the sink side to 3.3 V on the source side
- Integrated 200 kΩ pull-down resistor on HPD sink input guarantees 'input LOW' when no display is plugged in
- Back-power safe design on HPD\_SINK to disallow backdrive current when power is off

### 2.4 General

- Power supply 3.0 V to 3.6 V
- ESD resilience to 6 kV HBM, 1 kV CDM
- Power-saving modes (using output enable)
- Back-current-safe design on all sink-side main link, DDC and HPD terminals
- Transparent operation: no re-timing or software configuration required
- 32-terminal HVQFN32 package

## 3. Applications

- PC motherboard/graphics card
- Docking station
- DisplayPort to HDMI adapters supporting 4K × 2K and 3D video formats
- DisplayPort to DVI adapters required to drive long cables

## 4. Ordering information

Table 1. Ordering information

Type number	Topside mark	Package		
		Name	Description	Version
PTN3365BS	P3365	HVQFN32	plastic thermal enhanced very thin quad flat package; no leads; 32 terminals; body 5 x 5 x 0.85 mm	SOT617-3

### 4.1 Ordering options

Table 2. Ordering options

Type number	Orderable part number	Package	Packing method	Minimum order quantity	Temperature range
PTN3365BS	PTN3365BSMP	HVQFN32	Reel 13" Q2/T3 *standard mark SMD dry pack	6000	T <sub>amb</sub> = -40 °C to +85 °C

5. Functional diagram

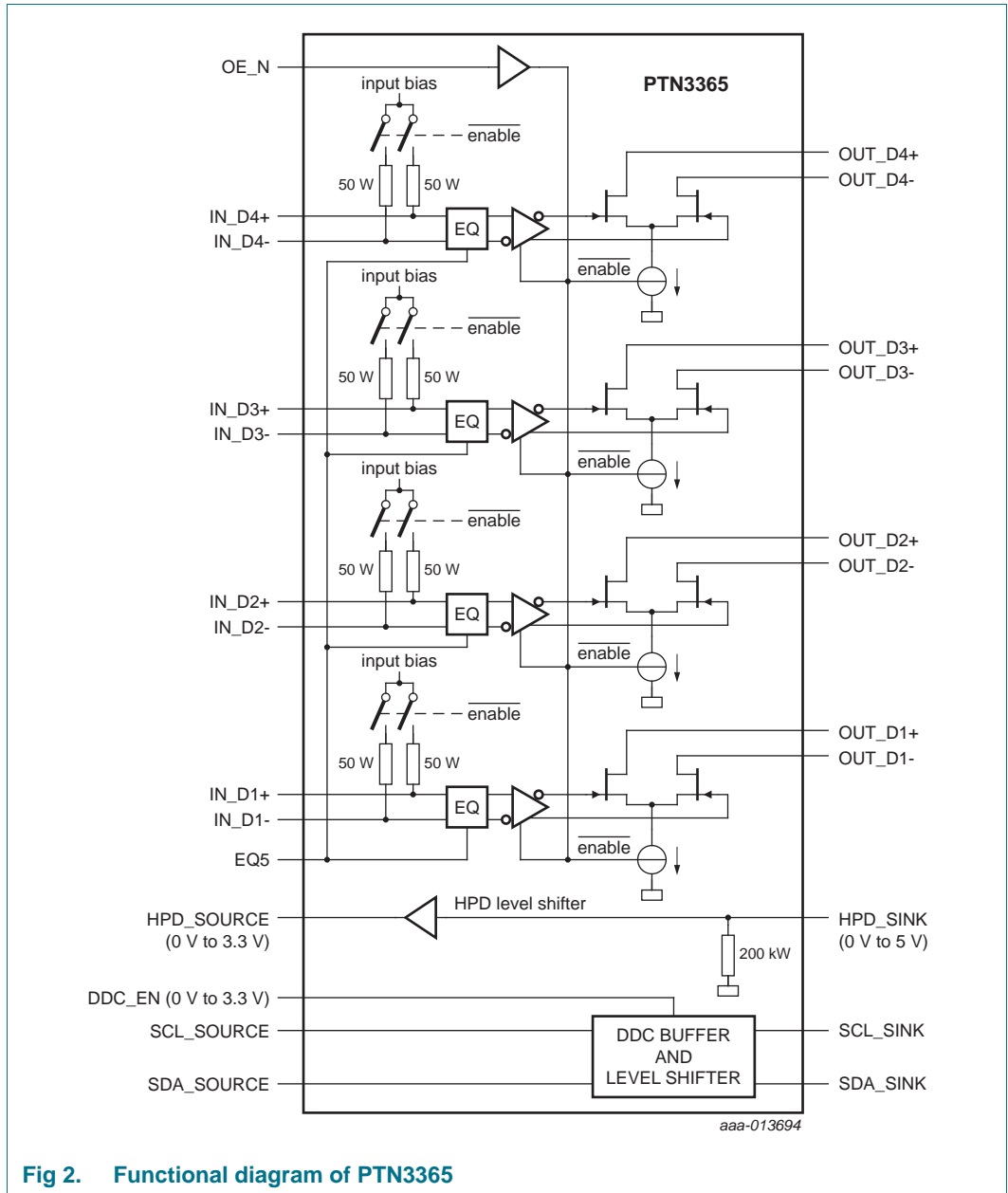
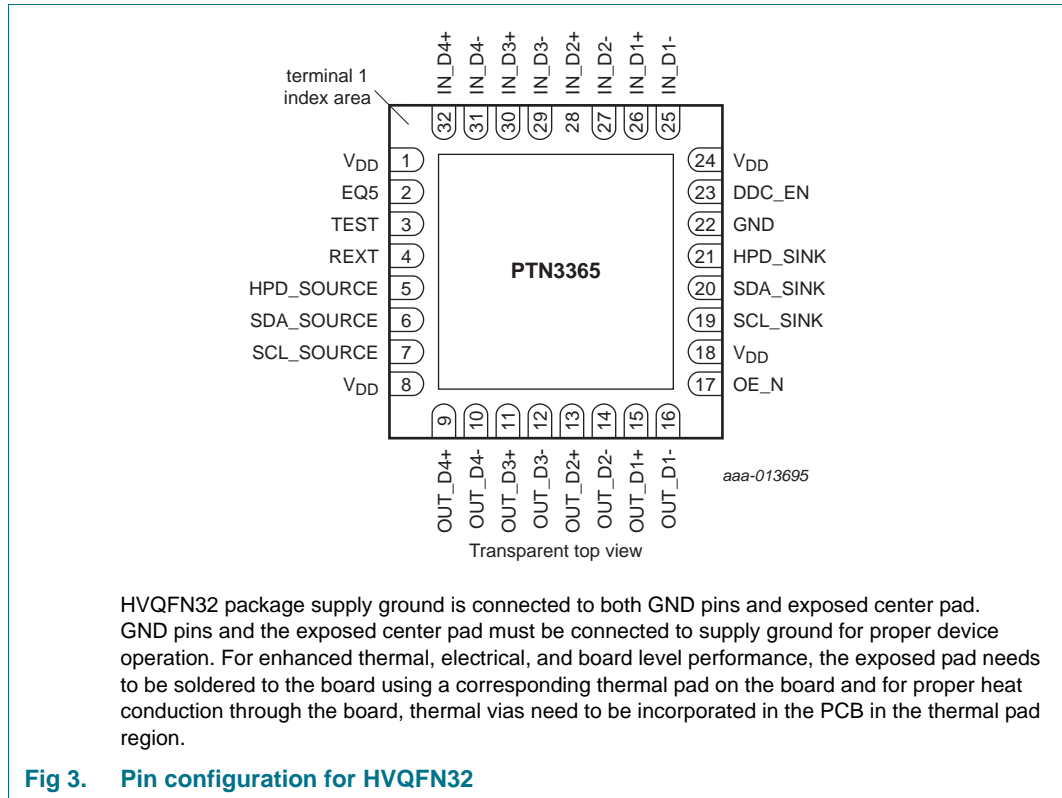

Fig 2. Functional diagram of PTN3365

## 6. Pinning information

### 6.1 Pinning



### 6.2 Pin description

Table 3. Pin description

Symbol	Pin	Type	Description
<b>OE_N, IN_Dx and OUT_Dx signals</b>			
OE_N	17	3.3 V low-voltage CMOS single-ended input	Output Enable and power saving function for high-speed differential level shifter path. When OE_N = HIGH: IN_Dx termination = high-impedance OUT_Dx outputs = high-impedance; zero output current When OE_N = LOW: IN_Dx termination = 50 Ω OUT_Dx outputs = active
IN_D4+	32	Self-biasing differential input	Low-swing differential input from display source with PCI Express electrical signaling. IN_D4+ makes a differential pair with IN_D4-. The input to this pin must be AC coupled externally.

Table 3. Pin description ...continued

Symbol	Pin	Type	Description
IN_D4-	31	Self-biasing differential input	Low-swing differential input from display source with PCI Express electrical signaling. IN_D4- makes a differential pair with IN_D4+. The input to this pin must be AC coupled externally.
IN_D3+	30	Self-biasing differential input	Low-swing differential input from display source with PCI Express electrical signaling. IN_D3+ makes a differential pair with IN_D3-. The input to this pin must be AC coupled externally.
IN_D3-	29	Self-biasing differential input	Low-swing differential input from display source with PCI Express electrical signaling. IN_D3- makes a differential pair with IN_D3+. The input to this pin must be AC coupled externally.
IN_D2+	28	Self-biasing differential input	Low-swing differential input from display source with PCI Express electrical signaling. IN_D2+ makes a differential pair with IN_D2-. The input to this pin must be AC coupled externally.
IN_D2-	27	Self-biasing differential input	Low-swing differential input from display source with PCI Express electrical signaling. IN_D2- makes a differential pair with IN_D2+. The input to this pin must be AC coupled externally.
IN_D1+	26	Self-biasing differential input	Low-swing differential input from display source with PCI Express electrical signaling. IN_D1+ makes a differential pair with IN_D1-. The input to this pin must be AC coupled externally.
IN_D1-	25	Self-biasing differential input	Low-swing differential input from display source with PCI Express electrical signaling. IN_D1- makes a differential pair with IN_D1+. The input to this pin must be AC coupled externally.
OUT_D4+	9	TMDS differential output	HDMI compliant TMDS output. OUT_D4+ makes a differential pair with OUT_D4-. OUT_D4+ is in phase with IN_D4+.
OUT_D4-	10	TMDS differential output	HDMI compliant TMDS output. OUT_D4- makes a differential pair with OUT_D4+. OUT_D4- is in phase with IN_D4-.
OUT_D3+	11	TMDS differential output	HDMI compliant TMDS output. OUT_D3+ makes a differential pair with OUT_D3-. OUT_D3+ is in phase with IN_D3+.
OUT_D3-	12	TMDS differential output	HDMI compliant TMDS output. OUT_D3- makes a differential pair with OUT_D3+. OUT_D3- is in phase with IN_D3-.
OUT_D2+	13	TMDS differential output	HDMI compliant TMDS output. OUT_D2+ makes a differential pair with OUT_D2-. OUT_D2+ is in phase with IN_D2+.

Table 3. Pin description ...continued

Symbol	Pin	Type	Description
OUT_D2-	14	TMDS differential output	HDMI compliant TMDS output. OUT_D2- makes a differential pair with OUT_D2+. OUT_D2- is in phase with IN_D2-.
OUT_D1+	15	TMDS differential output	HDMI compliant TMDS output. OUT_D1+ makes a differential pair with OUT_D1-. OUT_D1+ is in phase with IN_D1+.
OUT_D1-	16	TMDS differential output	HDMI compliant TMDS output. OUT_D1- makes a differential pair with OUT_D1+. OUT_D1- is in phase with IN_D1-.
<b>HPD and DDC signals</b>			
HPD_SINK	21	5 V CMOS single-ended input	0 V to 5 V (nominal) input signal. This signal comes from the DVI or HDMI sink. A HIGH value indicates that the sink is connected; a LOW value indicates that the sink is disconnected. HPD_SINK is pulled down by an integrated 200 k $\Omega$ pull-down resistor.
HPD_SOURCE	5	3.3 V CMOS single-ended output	0 V to 3.3 V (nominal) output signal. This is level-shifted version of the HPD_SINK signal.
SCL_SOURCE	7	single-ended 3.3 V open-drain DDC I/O	3.3 V source-side DDC clock I/O. Pulled up by external termination to 3.3 V. 5 V tolerant I/O.
SDA_SOURCE	6	single-ended 3.3 V open-drain DDC I/O	3.3 V source-side DDC data I/O. Pulled up by external termination to 3.3 V. 5 V tolerant I/O.
SCL_SINK	19	single-ended 5 V open-drain DDC I/O	5 V sink-side DDC clock I/O. Pulled up by external termination to 5 V. Provides rise time acceleration for LOW-to-HIGH transitions.
SDA_SINK	20	single-ended 5 V open-drain DDC I/O	5 V sink-side DDC data I/O. Pulled up by external termination to 5 V. Provides rise time acceleration for LOW-to-HIGH transitions.
DDC_EN	23	3.3 V CMOS input	Enables the DDC buffer and level shifter. When DDC_EN = LOW, buffer/level shifter is disabled. When DDC_EN = HIGH, buffer and level shifter are enabled.
TEST	3	3.3 V CMOS input	This is a test pin and it shall always be connected to GND in the system applications.
<b>Supply and ground</b>			
V <sub>DD</sub>	1, 8, 18, 24	3.3 V DC supply	Supply voltage; 3.3 V $\pm$ 10 %.
GND <sup>[1]</sup>	22	ground	Supply ground. All GND pins must be connected to ground for proper operation.

Table 3. Pin description ...continued

Symbol	Pin	Type	Description
<b>Feature control signals</b>			
REXT	4	analog I/O	Current sense port used to provide an accurate current reference for the differential outputs OUT_Dx. For best output voltage swing accuracy, use of a 10 k $\Omega$ resistor (1 % tolerance) from this terminal to GND is recommended. May also be tied to either V <sub>DD</sub> or GND directly (0 $\Omega$ ). See <a href="#">Section 7.2</a> for details.
EQ5	2	3.3 V low-voltage CMOS quinary input	Equalizer setting input pin. This pin can be board-strapped to one of five decode values: short to GND, resistor to GND, open-circuit, resistor to V <sub>DD</sub> , short to V <sub>DD</sub> . See <a href="#">Table 5</a> for truth table.

- [1] HVQFN32 package supply ground is connected to both GND pins and exposed center pad. GND pins and the exposed center pad must be connected to supply ground for proper device operation. For enhanced thermal, electrical, and board level performance, the exposed pad needs to be soldered to the board using a corresponding thermal pad on the board and for proper heat conduction through the board, thermal vias need to be incorporated in the PCB in the thermal pad region.

## 7. Functional description

Refer to [Figure 2 “Functional diagram of PTN3365”](#).

PTN3365 level shifts four lanes of low-swing AC-coupled differential input signals to DVI and HDMI compliant open-drain current-steering differential output signals, up to 3.0 Gbit/s per lane to support 36-bit deep color mode. It has integrated 50  $\Omega$  termination resistors for AC-coupled differential input signals. An enable signal OE\_N can be used to turn off the TMDS inputs and outputs, thereby minimizing power consumption. The TMDS outputs are back-power safe to disallow current flow from a powered sink while PTN3365 is unpowered.

PTN3365's DDC channel provides active level shifting and buffering, allowing 3.3 V source-side termination and 5 V sink-side termination. The sink-side DDC ports are equipped with a rise time accelerator enabling drive of long cables or high bus capacitance. This enables the system designer to isolate bus capacitance to meet/exceed HDMI DDC specification. PTN3365 offers back-power safe sink-side I/Os to disallow backdrive current from the DDC clock and data lines when power is off or when DDC is not enabled. An enable signal DCC\_EN enables the DDC level shifter block.

PTN3365 also provides voltage translation for the Hot Plug Detect (HPD) signal from 0 V to 5 V on the sink side to 0 V to 3.3 V on the source side.

PTN3365 does not re-time any data. It contains no state machines. No inputs or outputs of the device are latched or clocked. Because PTN3365 acts as a transparent level shifter, no reset is required.

### 7.1 Enable and disable features

PTN3365 offers different ways to enable or disable functionality, using the Output Enable (OE\_N), and DDC Enable (DCC\_EN) inputs. Whenever PTN3365 is disabled, the device will be in Standby mode and power consumption will be minimal; otherwise PTN3365 will be in active mode and power consumption will be nominal. These two inputs each affect the operation of PTN3365 differently: OE\_N controls the TMDS channels, DCC\_EN affects only the DDC channel, and HPD\_SINK does not affect either of the channels. The following sections and truth table describe their detailed operation.

#### 7.1.1 Hot plug detect

The HPD channel of PTN3365 functions as a level-shifting buffer to pass the HPD logic signal from the display sink device (via input HPD\_SINK) on to the display source device (via output HPD\_SOURCE).

The output logic state of HPD\_SOURCE output always follows the logic state of input HPD\_SINK, regardless of whether the device is in Active mode or Standby mode.

### 7.1.2 Output Enable function (OE\_N)

When input OE\_N is asserted (active LOW), the IN\_Dx and OUT\_Dx signals are fully functional. Input termination resistors are enabled and the internal bias circuits are turned on.

When OE\_N is de-asserted (inactive HIGH), the OUT\_Dx outputs are in a high-impedance state and drive zero output current. The IN\_Dx input buffers are disabled and IN\_Dx termination is disabled. Power consumption is minimized.

**Remark:** Note that OE\_N signal level has no influence on the HPD\_SINK input, HPD\_SOURCE output, or the SCL and SDA level shifters. A transition from HIGH to LOW at OE\_N may disable the DDC channel for up to 20  $\mu$ s.

### 7.1.3 DDC channel enable function (DDC\_EN)

The DDC\_EN pin is active HIGH and can be used to isolate a badly behaved slave. When DDC\_EN is LOW, the DDC channel is turned off. The DDC\_EN input should never change state during an I<sup>2</sup>C-bus operation. Note that disabling DDC\_EN during a bus operation may hang the bus, while enabling DDC\_EN during bus traffic would corrupt the I<sup>2</sup>C-bus operation. Hence, DDC\_EN should only be toggled while the bus is idle. (See I<sup>2</sup>C-bus specification).

## 7.1.4 Enable/disable truth table

Table 4. HPD\_SINK, OE\_N and DDC\_EN enabling truth table

Inputs			Channels				Mode
HPD_SINK	OE_N [1]	DDC_EN [2]	IN_Dx	OUT_Dx[3]	DDC[4]	HPD_SOURCE[5]	
LOW	LOW	LOW	50 $\Omega$ termination to $V_{RX(bias)}$	enabled	high-impedance	LOW	Active; DDC disabled
LOW	LOW	HIGH	50 $\Omega$ termination to $V_{RX(bias)}$	enabled	SDA_SINK connected to SDA_SOURCE and SCL_SINK connected to SCL_SOURCE	LOW	Active; DDC enabled
LOW	HIGH	LOW	high-impedance	high-impedance; zero output current	high-impedance	LOW	Standby
LOW	HIGH	HIGH	high-impedance	high-impedance; zero output current	SDA_SINK connected to SDA_SOURCE and SCL_SINK connected to SCL_SOURCE	LOW	Standby; DDC enabled
HIGH	LOW	LOW	50 $\Omega$ termination to $V_{RX(bias)}$	enabled	high-impedance	HIGH	Active; DDC disabled
HIGH	LOW	HIGH	50 $\Omega$ termination to $V_{RX(bias)}$	enabled	SDA_SINK connected to SDA_SOURCE and SCL_SINK connected to SCL_SOURCE	HIGH	Active; DDC enabled
HIGH	HIGH	LOW	high-impedance	high-impedance; zero output current	high-impedance	HIGH	Standby
HIGH	HIGH	HIGH	high-impedance	high-impedance; zero output current	SDA_SINK connected to SDA_SOURCE and SCL_SINK connected to SCL_SOURCE	HIGH	Standby; DDC enabled

[1] A HIGH level on input OE\_N disables only the TMDS channels. A transition from HIGH to LOW at OE\_N may disable the DDC channel for up to 20  $\mu$ s.

[2] A LOW level on input DDC\_EN disables only the DDC channel.

[3] OUT\_Dx channels 'enabled' means outputs OUT\_Dx toggling in accordance with IN\_Dx differential input voltage switching.

[4] DDC channel 'enabled' means SDA\_SINK is connected to SDA\_SOURCE and SCL\_SINK is connected to SCL\_SOURCE.

[5] The HPD\_SOURCE output logic state always follows the HPD\_SINK input logic state.

## 7.2 Analog current reference

The REXT pin (pin 6) is an analog current sense port used to provide an accurate current reference for the differential outputs OUT\_Dx. For best output voltage swing accuracy, use of a 10 k $\Omega$  resistor (1 % tolerance) connected between this terminal and GND is recommended.

If an external 10 k $\Omega$   $\pm$  1 % resistor is not used, this pin can be connected to GND or V<sub>DD</sub> directly (0  $\Omega$ ). In any of these cases, the output will function normally but at reduced accuracy over voltage and temperature of the following parameters: output levels (V<sub>OL</sub>), differential output voltage swing, and rise and fall time accuracy.

## 7.3 Equalizer

PTN3365 supports 5 level equalization setting by the quinary input pin EQ5.

**Table 5. Equalizer settings**

Inputs	Quinary notation	Equalizer mode
<b>EQ5</b>		
short to GND	0 <sub>5</sub>	0 dB
10 k $\Omega$ resistor to GND	1 <sub>5</sub>	2 dB
open-circuit	2 <sub>5</sub>	3.5 dB
10 k $\Omega$ resistor to V <sub>DD</sub>	3 <sub>5</sub>	9 dB
short to V <sub>DD</sub>	4 <sub>5</sub>	7 dB

## 7.4 Backdrive current protection

PTN3365 is designed for backdrive prevention on all sink-side TMDS outputs, sink-side DDC I/Os and the HPD\_SINK input. This supports user scenarios where the display is connected and powered, but PTN3365 is unpowered. In these cases, PTN3365 will sink no more than a negligible amount of leakage current, and will block the display (sink) termination network from driving the power supply of PTN3365 or that of the inactive DVI or HDMI source.

## 7.5 Active DDC buffer with rise time accelerator

PTN3365 DDC channel, besides providing 3.3 V to 5 V level shifting, includes active buffering and rise time acceleration which allows up to 18 meters bus extension for reliable DDC applications. While retaining all the operating modes and features of the I<sup>2</sup>C-bus system during the level shifts, it permits extension of the I<sup>2</sup>C-bus by providing bidirectional buffering for both the data (SDA) and the clock (SCL) line as well as the rise time accelerator on the sink-side port (SCL\_SINK and SDA\_SINK) enabling the bus to drive a load up to 1400 pF or distance of 18 m on the sink-side port, and 400 pF on the source-side port (SCL\_SOURCE and SCA\_SOURCE). Using PTN3365 for DVI or HDMI level shifting enables the system designer to isolate bus capacitance to meet/exceed HDMI DDC specification. The SDA and SCL pins are overvoltage tolerant and are high-impedance when PTN3365 is unpowered or when DDC\_EN is LOW.

PTN3365 has rise time accelerators on the sink-side port (SCL\_SINK and SDA\_SINK) only. During positive bus transitions on the sink-side port, a current source is switched on to quickly slew the SCL\_SINK and SDA\_SINK lines HIGH once the 5 V DDC bus  $V_{IL}$  threshold level of around 1.5 V is exceeded, and turns off as the 5 V DDC bus  $V_{IH}$  threshold voltage of approximately 3.5 V is approached.

## 8. Limiting values

**Table 6. Limiting values**

*In accordance with the Absolute Maximum Rating System (IEC 60134).*

Symbol	Parameter	Conditions	Min	Max	Unit
$V_{DD}$	supply voltage		-0.3	+4.6	V
$V_I$	input voltage	3.3 V CMOS inputs	-0.3	$V_{DD} + 0.5$	V
		5.0 V CMOS inputs	-0.3	6.0	V
$T_{stg}$	storage temperature		-65	+150	°C
$V_{ESD}$	electrostatic discharge voltage	HBM	[1] -	6000	V
		CDM	[2] -	1000	V

[1] Human Body Model: ANSI/EOS/ESD-S5.1-1994, standard for ESD sensitivity testing, Human Body Model - Component level; Electrostatic Discharge Association, Rome, NY, USA.

[2] Charged Device Model: ANSI/EOS/ESD-S5.3-1-1999, standard for ESD sensitivity testing, Charged Device Model - Component level; Electrostatic Discharge Association, Rome, NY, USA.

## 9. Recommended operating conditions

**Table 7. Recommended operating conditions**

Symbol	Parameter	Conditions	Min	Typ	Max	Unit
$V_{DD}$	supply voltage		3.0	3.3	3.6	V
$V_I$	input voltage	3.3 V CMOS inputs	0	-	3.6	V
		5.0 V CMOS inputs	0	-	5.5	V
$V_{I(AV)}$	average input voltage	IN_Dn+, IN_Dn- inputs	[1] -	0	-	V
$R_{ref(ext)}$	external reference resistance	connected between pin REXT (pin 6) and GND	[2] -	$10 \pm 1\%$	-	k $\Omega$
$T_{amb}$	ambient temperature	operating in free air	-40	-	+85	°C

[1] Input signals to these pins must be AC-coupled.

[2] Operation without external reference resistor is possible but will result in reduced output voltage swing accuracy. For details, see [Section 7.2](#).

### 9.1 Current consumption

**Table 8. Current consumption**

Symbol	Parameter	Conditions	Min	Typ	Max	Unit
$I_{DD}$	supply current	OE_N = 0; Active mode	-	70	100	mA
		OE_N = 1 and DDC_EN = 0; Standby mode	-	-	5	mA

## 10. Characteristics

### 10.1 Differential inputs

Table 9. Differential input characteristics for IN\_Dx signals

Symbol	Parameter	Conditions	Min	Typ	Max	Unit
UI	unit interval <sup>[1]</sup>		<sup>[2]</sup> 333	-	4000	ps
V <sub>RX_DIFFp-p</sub>	differential input peak-to-peak voltage		<sup>[3]</sup> 0.175	-	1.200	V
t <sub>RX_EYE</sub>	receiver eye time	minimum eye width at IN_Dx input pair	0.8	-	-	UI
V <sub>i(cm)M(AC)</sub>	peak common-mode input voltage (AC)	includes all frequencies above 30 kHz	<sup>[4]</sup> -	-	100	mV
Z <sub>RX_DC</sub>	DC input impedance		40	50	60	Ω
V <sub>RX(bias)</sub>	bias receiver voltage		1.0	1.2	1.4	V
Z <sub>I(se)</sub>	single-ended input impedance	inputs in high-impedance state	<sup>[5]</sup> 100	-	-	kΩ

[1] UI (unit interval) = t<sub>bit</sub> (bit time).

[2] UI is determined by the display mode. Nominal bit rate ranges from 250 Mbit/s to 3.0 Gbit/s per lane.

[3] V<sub>RX\_DIFFp-p</sub> = 2 × |V<sub>RX\_D+</sub> - V<sub>RX\_D-</sub>|. Applies to IN\_Dx signals.

[4] V<sub>i(cm)M(AC)</sub> = |V<sub>RX\_D+</sub> + V<sub>RX\_D-</sub>| / 2 - V<sub>RX(cm)</sub>.  
V<sub>RX(cm)</sub> = DC (avg) of |V<sub>RX\_D+</sub> + V<sub>RX\_D-</sub>| / 2.

[5] Differential inputs will switch to a high-impedance state when OE\_N is HIGH.

### 10.2 Differential outputs

The level shifter's differential outputs are designed to meet HDMI version 1.4a and DVI version 1.0 specifications.

Table 10. Differential output characteristics for OUT\_Dx signals

Symbol	Parameter	Conditions	Min	Typ	Max	Unit
V <sub>OH(se)</sub>	single-ended HIGH-level output voltage		<sup>[1]</sup> V <sub>TT</sub> - 0.01	V <sub>TT</sub>	V <sub>TT</sub> + 0.01	V
V <sub>OL(se)</sub>	single-ended LOW-level output voltage		<sup>[2]</sup> V <sub>TT</sub> - 0.60	V <sub>TT</sub> - 0.50	V <sub>TT</sub> - 0.40	V
ΔV <sub>O(se)</sub>	single-ended output voltage variation	logic 1 and logic 0 state applied respectively to differential inputs IN_Dn; R <sub>ref(ext)</sub> connected; see <a href="#">Table 7</a>	<sup>[3]</sup> 400	500	600	mV
I <sub>OZ</sub>	OFF-state output current	single-ended	-	-	10	μA
t <sub>r</sub>	rise time	20 % to 80 %	75	-	240	ps
t <sub>f</sub>	fall time	80 % to 20 %	75	-	240	ps
t <sub>sk</sub>	skew time	intra-pair	<sup>[4]</sup> -	-	10	ps
		inter-pair	<sup>[5]</sup> -	-	250	ps
t <sub>jit(add)</sub>	added jitter time	jitter contribution	<sup>[6]</sup> -	10	-	ps

[1] V<sub>TT</sub> is the DC termination voltage in the HDMI or DVI sink. V<sub>TT</sub> is nominally 3.3 V.

[2] The open-drain output pulls down from V<sub>TT</sub>.

[3] Swing down from TMDS termination voltage (3.3 V ± 10 %).

- [4] This differential skew budget is in addition to the skew presented between IN\_D+ and IN\_D- paired input pins.
- [5] This lane-to-lane skew budget is in addition to skew between differential input pairs.
- [6] Jitter budget for differential signals as they pass through the level shifter.

### 10.3 HPD\_SINK input, HPD\_SOURCE output

Table 11. HPD characteristics

Symbol	Parameter	Conditions		Min	Typ	Max	Unit
V <sub>IH</sub>	HIGH-level input voltage	HPD_SINK	[1]	2.0	5.0	5.3	V
V <sub>IL</sub>	LOW-level input voltage	HPD_SINK		0	-	0.8	V
I <sub>LI</sub>	input leakage current	HPD_SINK		-	-	15	μA
V <sub>OH</sub>	HIGH-level output voltage	HPD_SOURCE		2.5	-	V <sub>DD</sub>	V
V <sub>OL</sub>	LOW-level output voltage	HPD_SOURCE		0	-	0.2	V
t <sub>PD</sub>	propagation delay	from HPD_SINK to HPD_SOURCE; 50 % to 50 %	[2]	-	-	200	ns
t <sub>t</sub>	transition time	HPD_SOURCE rise/fall; 10 % to 90 %	[3]	1	-	20	ns
R <sub>pd</sub>	pull-down resistance	HPD_SINK input pull-down resistor	[4]	100	200	300	kΩ

- [1] Low-speed input changes state on cable plug/unplug.
- [2] Time from HPD\_SINK changing state to HPD\_SOURCE changing state. Includes HPD\_SOURCE rise/fall time.
- [3] Time required to transition from V<sub>OH</sub> to V<sub>OL</sub> or from V<sub>OL</sub> to V<sub>OH</sub>.
- [4] Guarantees HPD\_SINK is LOW when no display is plugged in.

### 10.4 OE\_N, DDC\_EN and test inputs

Table 12. OE\_N, DDC\_EN input characteristics

Symbol	Parameter	Conditions		Min	Typ	Max	Unit
V <sub>IH</sub>	HIGH-level input voltage			2.0	-		V
V <sub>IL</sub>	LOW-level input voltage				-	0.8	V
I <sub>LI</sub>	input leakage current	OE_N pin	[1]	-	-	10	μA

- [1] Measured with input at V<sub>IH</sub> maximum and V<sub>IL</sub> minimum.

## 10.5 DDC characteristics

Table 13. DDC characteristics

Symbol	Parameter	Conditions	Min	Typ	Max	Unit
<b>Input and output SCL_SOURCE and SDA_SOURCE, <math>V_{CC1} = 3.0\text{ V to }3.6\text{ V}</math> [1]</b>						
$V_{IH}$	HIGH-level input voltage		$0.7V_{CC1}$	-	3.6	V
$V_{ILc}$	contention LOW-level input voltage	guaranteed by design	-0.5	-	0.4	V
$I_{LI}$	input leakage current	$V_I = 3.6\text{ V}$	-	-	10	$\mu\text{A}$
$I_{IL}$	LOW-level input current	$V_I = 0.2\text{ V}$	-	-	10	$\mu\text{A}$
$V_{OL}$	LOW-level output voltage	$I_{OL} = 6\text{ mA}$	[2] 0.47	0.52	0.6	V
$V_{OL}-V_{ILc}$	difference between LOW-level output and LOW-level input voltage contention	guaranteed by design	-	-	70	mV
$C_{io}$	input/output capacitance	$V_I = 3\text{ V or }0\text{ V}; V_{DD} = 3.3\text{ V}$	-	6	7	pF
		$V_I = 3\text{ V or }0\text{ V}; V_{DD} = 0\text{ V}$	-	6	7	pF
<b>Input and output SDA_SINK and SCL_SINK, <math>V_{CC2} = 4.5\text{ V to }5.5\text{ V}</math> [3]</b>						
$V_{IH}$	HIGH-level input voltage		$0.7V_{CC2}$	-	5.5	V
$V_{IL}$	LOW-level input voltage		-0.5	-	+1.2	V
$I_{LI}$	input leakage current	$V_I = 5.5\text{ V}$	-	-	10	$\mu\text{A}$
$I_{IL}$	LOW-level input current	$V_I = 0.2\text{ V}$	-	-	10	$\mu\text{A}$
$V_{OL}$	LOW-level output voltage	$I_{OL} = 6\text{ mA}$	-	0.1	0.2	V
$C_{io}$	input/output capacitance	$V_I = 3\text{ V or }0\text{ V}; V_{DD} = 3.3\text{ V}$	-	-	7	pF
		$V_I = 3\text{ V or }0\text{ V}; V_{DD} = 0\text{ V}$	-	6	7	pF
$I_{trt(pu)}$	transient boosted pull-up current	$V_{CC2} = 4.5\text{ V};$ slew rate = $1.25\text{ V}/\mu\text{s}$	-	6	-	mA

[1]  $V_{CC1}$  is the pull-up voltage for DDC source.

[2]  $I_{OL}$  between 100  $\mu\text{A}$  and 6 mA guaranteed by design (3 mA typical application)

[3]  $V_{CC2}$  is the pull-up voltage for DDC sink.

11. Package outline

HVQFN32: plastic thermal enhanced very thin quad flat package; no leads; 32 terminals; body 5 x 5 x 0.85 mm

SOT617-3

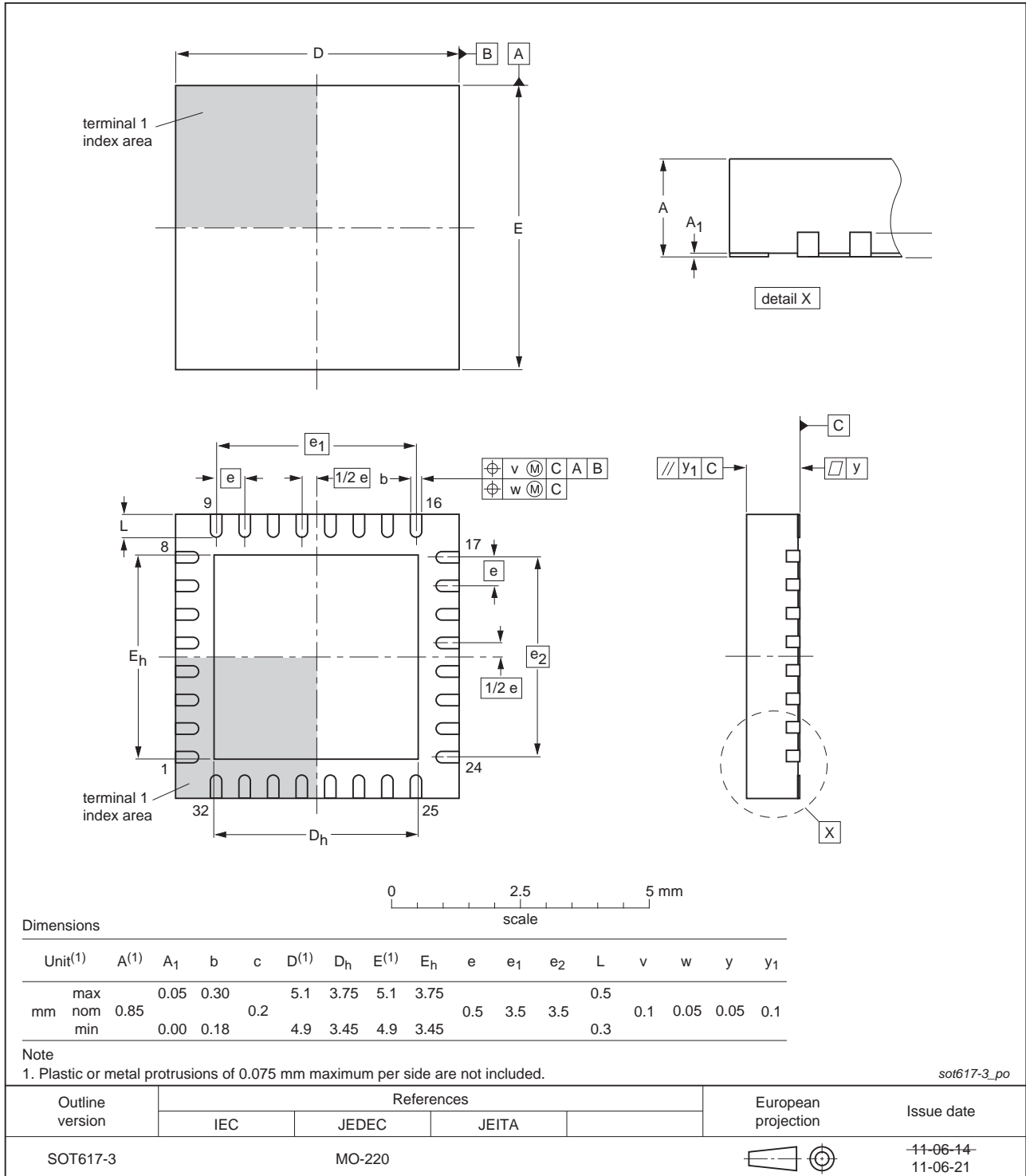

Fig 4. Package outline SOT617-3 (HVQFN32)

## 12. Soldering of SMD packages

This text provides a very brief insight into a complex technology. A more in-depth account of soldering ICs can be found in Application Note *AN10365 "Surface mount reflow soldering description"*.

### 12.1 Introduction to soldering

Soldering is one of the most common methods through which packages are attached to Printed Circuit Boards (PCBs), to form electrical circuits. The soldered joint provides both the mechanical and the electrical connection. There is no single soldering method that is ideal for all IC packages. Wave soldering is often preferred when through-hole and Surface Mount Devices (SMDs) are mixed on one printed wiring board; however, it is not suitable for fine pitch SMDs. Reflow soldering is ideal for the small pitches and high densities that come with increased miniaturization.

### 12.2 Wave and reflow soldering

Wave soldering is a joining technology in which the joints are made by solder coming from a standing wave of liquid solder. The wave soldering process is suitable for the following:

- Through-hole components
- Leaded or leadless SMDs, which are glued to the surface of the printed circuit board

Not all SMDs can be wave soldered. Packages with solder balls, and some leadless packages which have solder lands underneath the body, cannot be wave soldered. Also, leaded SMDs with leads having a pitch smaller than ~0.6 mm cannot be wave soldered, due to an increased probability of bridging.

The reflow soldering process involves applying solder paste to a board, followed by component placement and exposure to a temperature profile. Leaded packages, packages with solder balls, and leadless packages are all reflow solderable.

Key characteristics in both wave and reflow soldering are:

- Board specifications, including the board finish, solder masks and vias
- Package footprints, including solder thieves and orientation
- The moisture sensitivity level of the packages
- Package placement
- Inspection and repair
- Lead-free soldering versus SnPb soldering

### 12.3 Wave soldering

Key characteristics in wave soldering are:

- Process issues, such as application of adhesive and flux, clinching of leads, board transport, the solder wave parameters, and the time during which components are exposed to the wave
- Solder bath specifications, including temperature and impurities

## 12.4 Reflow soldering

Key characteristics in reflow soldering are:

- Lead-free versus SnPb soldering; note that a lead-free reflow process usually leads to higher minimum peak temperatures (see [Figure 5](#)) than a SnPb process, thus reducing the process window
- Solder paste printing issues including smearing, release, and adjusting the process window for a mix of large and small components on one board
- Reflow temperature profile; this profile includes preheat, reflow (in which the board is heated to the peak temperature) and cooling down. It is imperative that the peak temperature is high enough for the solder to make reliable solder joints (a solder paste characteristic). In addition, the peak temperature must be low enough that the packages and/or boards are not damaged. The peak temperature of the package depends on package thickness and volume and is classified in accordance with [Table 14](#) and [15](#)

**Table 14. SnPb eutectic process (from J-STD-020D)**

Package thickness (mm)	Package reflow temperature (°C)	
	Volume (mm <sup>3</sup> )	
	< 350	≥ 350
< 2.5	235	220
≥ 2.5	220	220

**Table 15. Lead-free process (from J-STD-020D)**

Package thickness (mm)	Package reflow temperature (°C)		
	Volume (mm <sup>3</sup> )		
	< 350	350 to 2000	> 2000
< 1.6	260	260	260
1.6 to 2.5	260	250	245
> 2.5	250	245	245

Moisture sensitivity precautions, as indicated on the packing, must be respected at all times.

Studies have shown that small packages reach higher temperatures during reflow soldering, see [Figure 5](#).

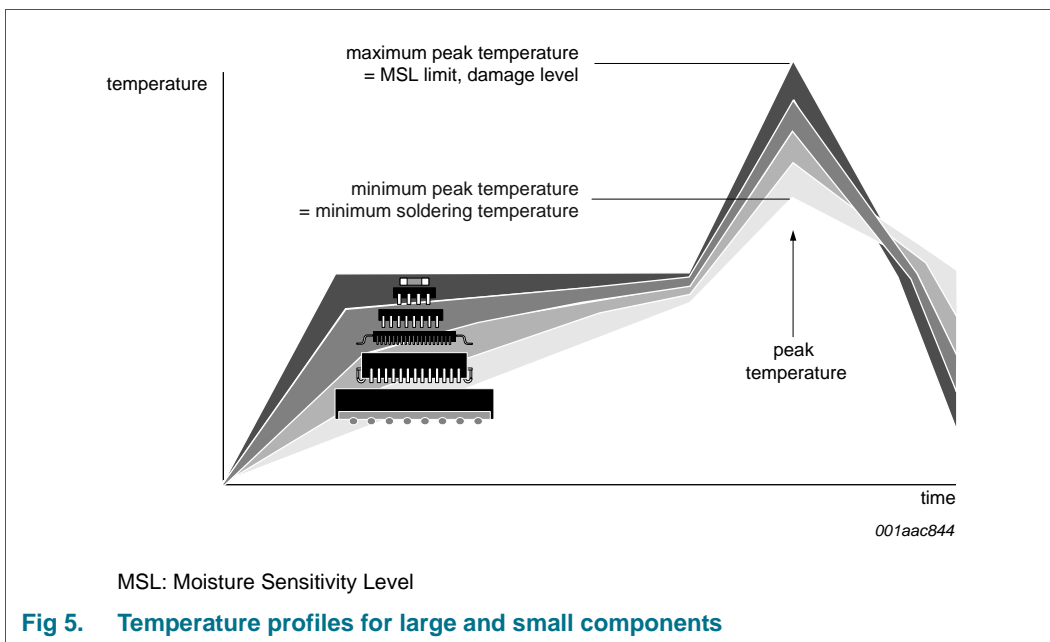

For further information on temperature profiles, refer to Application Note AN10365 “Surface mount reflow soldering description”.

### 13. Abbreviations

Table 16. Abbreviations

Acronym	Description
CDM	Charged-Device Model
CEC	Consumer Electronics Control
DDC	Data Display Channel
DVI	Digital Visual Interface
EMI	ElectroMagnetic Interference
ESD	ElectroStatic Discharge
HBM	Human Body Model
HDMI	High-Definition Multimedia Interface
HPD	Hot Plug Detect
I <sup>2</sup> C-bus	Inter-IC bus
I/O	Input/Output
NMOS	Negative-channel Metal-Oxide Semiconductor
TMDS	Transition Minimized Differential Signaling
VESA	Video Electronic Standards Association

## 14. Revision history

Table 17. Revision history

Document ID	Release date	Data sheet status	Change notice	Supersedes
PTN3365 v.1.1	20150728	Product data sheet	-	PTN3365 v.1
Modifications:	• Changed document status to Company Public.			
PTN3365 v.1	20141203	Product data sheet	-	-

## 15. Legal information

### 15.1 Data sheet status

Document status <sup>[1][2]</sup>	Product status <sup>[3]</sup>	Definition
Objective [short] data sheet	Development	This document contains data from the objective specification for product development.
Preliminary [short] data sheet	Qualification	This document contains data from the preliminary specification.
Product [short] data sheet	Production	This document contains the product specification.

[1] Please consult the most recently issued document before initiating or completing a design.

[2] The term 'short data sheet' is explained in section "Definitions".

[3] The product status of device(s) described in this document may have changed since this document was published and may differ in case of multiple devices. The latest product status information is available on the Internet at URL <http://www.nxp.com>.

### 15.2 Definitions

**Draft** — The document is a draft version only. The content is still under internal review and subject to formal approval, which may result in modifications or additions. NXP Semiconductors does not give any representations or warranties as to the accuracy or completeness of information included herein and shall have no liability for the consequences of use of such information.

**Short data sheet** — A short data sheet is an extract from a full data sheet with the same product type number(s) and title. A short data sheet is intended for quick reference only and should not be relied upon to contain detailed and full information. For detailed and full information see the relevant full data sheet, which is available on request via the local NXP Semiconductors sales office. In case of any inconsistency or conflict with the short data sheet, the full data sheet shall prevail.

**Product specification** — The information and data provided in a Product data sheet shall define the specification of the product as agreed between NXP Semiconductors and its customer, unless NXP Semiconductors and customer have explicitly agreed otherwise in writing. In no event however, shall an agreement be valid in which the NXP Semiconductors product is deemed to offer functions and qualities beyond those described in the Product data sheet.

### 15.3 Disclaimers

**Limited warranty and liability** — Information in this document is believed to be accurate and reliable. However, NXP Semiconductors does not give any representations or warranties, expressed or implied, as to the accuracy or completeness of such information and shall have no liability for the consequences of use of such information. NXP Semiconductors takes no responsibility for the content in this document if provided by an information source outside of NXP Semiconductors.

In no event shall NXP Semiconductors be liable for any indirect, incidental, punitive, special or consequential damages (including - without limitation - lost profits, lost savings, business interruption, costs related to the removal or replacement of any products or rework charges) whether or not such damages are based on tort (including negligence), warranty, breach of contract or any other legal theory.

Notwithstanding any damages that customer might incur for any reason whatsoever, NXP Semiconductors' aggregate and cumulative liability towards customer for the products described herein shall be limited in accordance with the *Terms and conditions of commercial sale* of NXP Semiconductors.

**Right to make changes** — NXP Semiconductors reserves the right to make changes to information published in this document, including without limitation specifications and product descriptions, at any time and without notice. This document supersedes and replaces all information supplied prior to the publication hereof.

**Suitability for use** — NXP Semiconductors products are not designed, authorized or warranted to be suitable for use in life support, life-critical or safety-critical systems or equipment, nor in applications where failure or malfunction of an NXP Semiconductors product can reasonably be expected to result in personal injury, death or severe property or environmental damage. NXP Semiconductors and its suppliers accept no liability for inclusion and/or use of NXP Semiconductors products in such equipment or applications and therefore such inclusion and/or use is at the customer's own risk.

**Applications** — Applications that are described herein for any of these products are for illustrative purposes only. NXP Semiconductors makes no representation or warranty that such applications will be suitable for the specified use without further testing or modification.

Customers are responsible for the design and operation of their applications and products using NXP Semiconductors products, and NXP Semiconductors accepts no liability for any assistance with applications or customer product design. It is customer's sole responsibility to determine whether the NXP Semiconductors product is suitable and fit for the customer's applications and products planned, as well as for the planned application and use of customer's third party customer(s). Customers should provide appropriate design and operating safeguards to minimize the risks associated with their applications and products.

NXP Semiconductors does not accept any liability related to any default, damage, costs or problem which is based on any weakness or default in the customer's applications or products, or the application or use by customer's third party customer(s). Customer is responsible for doing all necessary testing for the customer's applications and products using NXP Semiconductors products in order to avoid a default of the applications and the products or of the application or use by customer's third party customer(s). NXP does not accept any liability in this respect.

**Limiting values** — Stress above one or more limiting values (as defined in the Absolute Maximum Ratings System of IEC 60134) will cause permanent damage to the device. Limiting values are stress ratings only and (proper) operation of the device at these or any other conditions above those given in the Recommended operating conditions section (if present) or the Characteristics sections of this document is not warranted. Constant or repeated exposure to limiting values will permanently and irreversibly affect the quality and reliability of the device.

**Terms and conditions of commercial sale** — NXP Semiconductors products are sold subject to the general terms and conditions of commercial sale, as published at <http://www.nxp.com/profile/terms>, unless otherwise agreed in a valid written individual agreement. In case an individual agreement is concluded only the terms and conditions of the respective agreement shall apply. NXP Semiconductors hereby expressly objects to applying the customer's general terms and conditions with regard to the purchase of NXP Semiconductors products by customer.

**No offer to sell or license** — Nothing in this document may be interpreted or construed as an offer to sell products that is open for acceptance or the grant, conveyance or implication of any license under any copyrights, patents or other industrial or intellectual property rights.

**Export control** — This document as well as the item(s) described herein may be subject to export control regulations. Export might require a prior authorization from competent authorities.

**Non-automotive qualified products** — Unless this data sheet expressly states that this specific NXP Semiconductors product is automotive qualified, the product is not suitable for automotive use. It is neither qualified nor tested in accordance with automotive testing or application requirements. NXP Semiconductors accepts no liability for inclusion and/or use of non-automotive qualified products in automotive equipment or applications.

In the event that customer uses the product for design-in and use in automotive applications to automotive specifications and standards, customer (a) shall use the product without NXP Semiconductors' warranty of the product for such automotive applications, use and specifications, and (b) whenever customer uses the product for automotive applications beyond NXP Semiconductors' specifications such use shall be solely at customer's own risk, and (c) customer fully indemnifies NXP Semiconductors for any liability, damages or failed product claims resulting from customer design and use of the product for automotive applications beyond NXP Semiconductors' standard warranty and NXP Semiconductors' product specifications.

**Translations** — A non-English (translated) version of a document is for reference only. The English version shall prevail in case of any discrepancy between the translated and English versions.

## 15.4 Licenses

### Purchase of NXP ICs with HDMI technology

Use of an NXP IC with HDMI technology in equipment that complies with the HDMI standard requires a license from HDMI Licensing LLC, 1060 E. Arques Avenue Suite 100, Sunnyvale CA 94085, USA, e-mail: [admin@hdmi.org](mailto:admin@hdmi.org).

## 15.5 Trademarks

Notice: All referenced brands, product names, service names and trademarks are the property of their respective owners.

## 16. Contact information

For more information, please visit: <http://www.nxp.com>

For sales office addresses, please send an email to: [salesaddresses@nxp.com](mailto:salesaddresses@nxp.com)

## 17. Contents

<b>1</b>	<b>General description</b> . . . . .	<b>1</b>	15.5	Trademarks . . . . .	24
<b>2</b>	<b>Features and benefits</b> . . . . .	<b>3</b>	<b>16</b>	<b>Contact information</b> . . . . .	<b>24</b>
2.1	High-speed TMDS level shifting . . . . .	3	<b>17</b>	<b>Contents</b> . . . . .	<b>25</b>
2.2	DDC level shifting . . . . .	3			
2.3	HPD level shifting . . . . .	3			
2.4	General . . . . .	3			
<b>3</b>	<b>Applications</b> . . . . .	<b>3</b>			
<b>4</b>	<b>Ordering information</b> . . . . .	<b>4</b>			
4.1	Ordering options . . . . .	4			
<b>5</b>	<b>Functional diagram</b> . . . . .	<b>5</b>			
<b>6</b>	<b>Pinning information</b> . . . . .	<b>6</b>			
6.1	Pinning . . . . .	6			
6.2	Pin description . . . . .	6			
<b>7</b>	<b>Functional description</b> . . . . .	<b>10</b>			
7.1	Enable and disable features . . . . .	10			
7.1.1	Hot plug detect . . . . .	10			
7.1.2	Output Enable function (OE_N) . . . . .	11			
7.1.3	DDC channel enable function (DDC_EN) . . . . .	11			
7.1.4	Enable/disable truth table . . . . .	12			
7.2	Analog current reference . . . . .	13			
7.3	Equalizer . . . . .	13			
7.4	Backdrive current protection . . . . .	13			
7.5	Active DDC buffer with rise time accelerator . . . . .	13			
<b>8</b>	<b>Limiting values</b> . . . . .	<b>14</b>			
<b>9</b>	<b>Recommended operating conditions</b> . . . . .	<b>14</b>			
9.1	Current consumption . . . . .	14			
<b>10</b>	<b>Characteristics</b> . . . . .	<b>15</b>			
10.1	Differential inputs . . . . .	15			
10.2	Differential outputs . . . . .	15			
10.3	HPD_SINK input, HPD_SOURCE output . . . . .	16			
10.4	OE_N, DDC_EN and test inputs . . . . .	16			
10.5	DDC characteristics . . . . .	17			
<b>11</b>	<b>Package outline</b> . . . . .	<b>18</b>			
<b>12</b>	<b>Soldering of SMD packages</b> . . . . .	<b>19</b>			
12.1	Introduction to soldering . . . . .	19			
12.2	Wave and reflow soldering . . . . .	19			
12.3	Wave soldering . . . . .	19			
12.4	Reflow soldering . . . . .	20			
<b>13</b>	<b>Abbreviations</b> . . . . .	<b>21</b>			
<b>14</b>	<b>Revision history</b> . . . . .	<b>22</b>			
<b>15</b>	<b>Legal information</b> . . . . .	<b>23</b>			
15.1	Data sheet status . . . . .	23			
15.2	Definitions . . . . .	23			
15.3	Disclaimers . . . . .	23			
15.4	Licenses . . . . .	24			

Please be aware that important notices concerning this document and the product(s) described herein, have been included in section 'Legal information'.

© NXP Semiconductors N.V. 2015.

All rights reserved.

For more information, please visit: <http://www.nxp.com>



For sales office addresses, please send an email to: [salesaddresses@nxp.com](mailto:salesaddresses@nxp.com)

Date of release: 28 July 2015

Document identifier: PTN3365

## Looking for pricing, stock, or lifecycle information?

Click below to explore more details on WIN SOURCE:

-  [View PTN3365BSMP on WIN SOURCE](#)
-  [NXP / Nexperia Information](#)

## Optimize Your Supply Chain with WIN SOURCE Solutions

-  Global Sourcing Solution
-  Obsolete Management
-  Cost Control Management
-  Shortage Management
-  Alternative Solution
-  Excess Inventory Management